

BLD-E1 Series

User Manual

Brushless DC Motor Drive



www.delta.com.tw/industrialautomation

Preface

Thank you for choosing DELTA's multi-function BLD-E1 Series. The BLD-E1 Series is manufactured with high-quality components and materials and incorporate the latest microprocessor technology available.

This manual is to be used for the installation, parameter setting, troubleshooting, and daily maintenance of the brushless DC motor drive. To guarantee safe operation of the equipment, read the following safety guidelines before connecting power to the brushless DC motor drive. Keep this operating manual at hand and distribute to all users for reference.+

To ensure the safety of operators and equipment, only qualified personnel familiar with brushless DC motor drive are to do installation, trial run and parameter setting. Always read this manual thoroughly before using BLD-E1 series, especially the WARNING, DANGER and CAUTION notes. Failure to comply may result in personal injury and equipment damage. If you have any question, please contact your dealer.

PLEASE READ PRIOR TO INSTALLATION FOR SAFETY.



-
1. DC input power must be disconnected before any wiring to the brushless DC motor drive is made.
 2. There are highly sensitive MOS components on the printed circuit boards. These components are especially sensitive to static electricity. To prevent damage to these components, do not touch these components or the circuit boards with metal objects or your bare hands.
 3. Never reassemble internal components or wiring.
 4. Ground the BLD-E1 using the ground terminal. The grounding method must comply with the laws of the country where the brushless DC motor drive is to be installed. Refer to the Basic Wiring Diagram.
 5. BLD-E1 series is used only to control variable speed of 3-phase induction motors, NOT for 1-phase motors or other purpose.
 6. BLD-E1 series shall NOT be used for life support equipment or any life safety situation.
 7. To prevent personal injury, please keep children and unqualified people away from the equipment.



WARNING!

- Never connect the output terminals U/T1, V/T2, and W/T3 of brushless DC motor drive directly to the AC mains circuit power supply.
- DO NOT use Hi-pot test for internal components. The semiconductor used in brushless DC motor drive easily damage by high-voltage.
- A charge may still remain in the DC-link capacitors with hazardous voltages, even if the power has been turned off. To prevent personal injury, please ensure that power has turned off before opening the brushless DC motor drive and wait for the capacitors to discharge to safe voltage levels.
- Only qualified persons are allowed to install, wire and maintain brushless DC motor drives.
- Some parameters settings can cause the motor to run immediately after applying power.



CAUTION!

DO NOT install the brushless DC motor drive in a place subjected to high temperature, direct sunlight, high humidity or liquids.

Only use brushless DC motor drives within specification. Failure to comply may result in fire, explosion or electric shock.

When the motor cable between brushless DC motor drive and motor is too long, the layer insulation of the motor may be damaged. Please use a specific brushless DC motor for the brushless DC motor drive or add a reactor to prevent damage to the motor. Refer to appendix B Reactor for details.

The rated voltage for brushless DC motor drive must be $\leq 240V$ ($\leq 120V$ for 115V models and $\leq 480V$ for 460V models).

Table of Contents

Preface	i
Table of Contents	iii
Chapter 1 Introduction	1-1
1.1 Receiving and Inspection	1-2
1.1.1 Nameplate Information	1-2
1.1.2 Model Explanation	1-2
1.1.3 Series Number Explanation	1-3
1.1.4 Drive Frames and Appearances	1-3
1.1.5 Remove Instructions	1-8
1.2 Preparation for Installation and Wiring	1-8
1.2.1 Ambient Conditions	1-8
1.2.2 DC-bus Sharing: Connecting the DC-bus of the Brushless DC motor drive in Parallel	1-10
1.3 Dimensions	1-12
Chapter 2 Installation and Wiring	2-1
2.1 Wiring	2-2
2.2 External Wiring	2-6
2.3 Main Circuit	2-7
2.3.1 Main Circuit Connection	2-7
2.3.2 Main Circuit Terminals	2-9
2.4 Control Terminals	2-10

Chapter 3 Keypad and Start Up	3-1
3.1 Keypad.....	3-2
3.2 Operation Method	3-6
3.3 Trial Run	3-8
Chapter 4 Parameters.....	4-1
4.1 Summary of Parameter Settings	4-2
4.2 Description for Parameter Settings	4-33
Chapter 5 Troubleshooting	5-1
5.1 Over Current (OC).....	5-1
5.2 Ground Fault	5-2
5.3 Over Voltage (OV).....	5-2
5.4 Low Voltage (Lv)	5-3
5.5 Over Heat (OH).....	5-4
5.6 Overload	5-4
5.7 Keypad Display is Abnormal	5-5
5.8 Phase Loss (PHL)	5-5
5.9 Motor cannot Run.....	5-6
5.10 Motor Speed cannot be Changed	5-7
5.11 Motor Stalls during Acceleration.....	5-8
5.12 Electromagnetic/Induction Noise.....	5-9
5.13 Environmental Condition	5-9
5.14 Affecting Other Machines	5-10
Chapter 6 Fault Code Information and Maintenance	6-1
6.1 Fault Code Information.....	6-1
6.1.1 Common Problems and Solutions	6-2

6.1.2 Reset	6-7
6.2 Maintenance and Inspections	6-7
Appendix A Specifications	A-1
Appendix B Accessories	B-1
B.1 All Brake Resistors & Brake Units Used in the Brushless DC Motor Drive	B-1
B.1.1 Dimensions and Weights for Brake Resistors	B-3
B.2 No-fuse Circuit Breaker Chart	B-6
B.3 Fuse Specification Chart	B-7
B.4 AC Reactor.....	B-8
B.4.1 AC Input Reactor Recommended Value.....	B-8
B.4.2 AC Output Reactor Recommended Value	B-8
B.4.3 Applications	B-9
B.5 Zero Phase Reactor (RF220X00A)	B-11
B.6 DIN Rail	B-12

This page intentionally left blank

Chapter 1 Introduction

The brushless DC motor drive should be kept in the shipping carton or crate before installation. In order to retain the warranty coverage, the brushless DC motor drive should be stored properly when it is not to be used for an extended period of time. Storage conditions are:



CAUTION!

1. Store in a clean and dry location free from direct sunlight or corrosive fumes.
2. Store within an ambient temperature range of -20 °C to +60 °C.
3. Store within a relative humidity range of 0% to 90% and non-condensing environment.
4. DO NOT place on the ground directly. It should be stored properly. Moreover, if the surrounding environment is humid, you should put exsiccator in the package.
5. DO NOT store in an area with rapid changes in temperature. It may cause condensation and frost.
6. If the brushless DC motor drive is stored for more than 3 months, the temperature should not be higher than 30 °C. Storage longer than one year is not recommended, it could result in the degradation of the electrolytic capacitors.
7. When the brushless DC motor drive is not used for longer time after installation on building sites or places with humidity and dust, it's best to move the brushless DC motor drive to an environment as stated above.

1.1 Receiving and Inspection

This BLD-E1 brushless DC motor drive has gone through rigorous quality control tests at the factory before shipment. After receiving the brushless DC motor drive, please check for the following:

- Inspect the unit to assure it was not damaged during shipment.
- Make sure that the part number indicated on the nameplate corresponds with the part number of your order.

1.1.1 Nameplate Information

Example for 1HP/0.75kW 3-phase 230V brushless DC motor drive

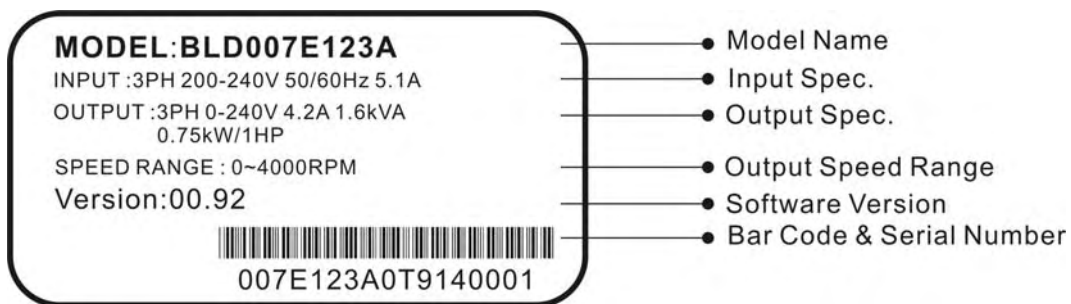

1.1.2 Model Explanation

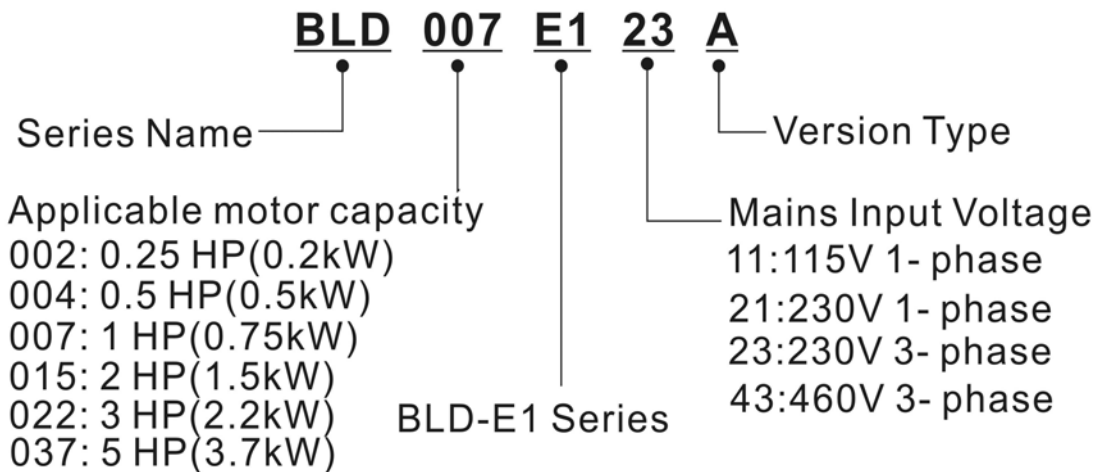

1.1.3 Series Number Explanation

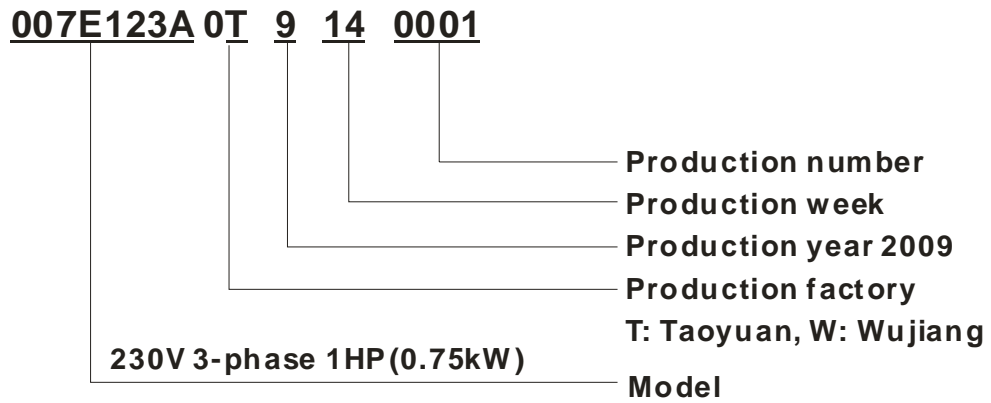

If the nameplate information does not correspond to your purchase order or if there are any problems, please contact your distributor.

1.1.4 Drive Frames and Appearances

0.25-2HP/0.2-1.5kW (Frame A)

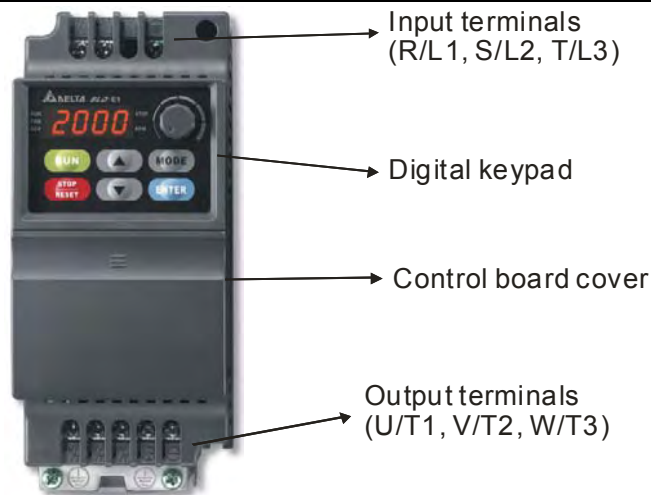

1-5HP/0.75-3.7kW (Frame B)

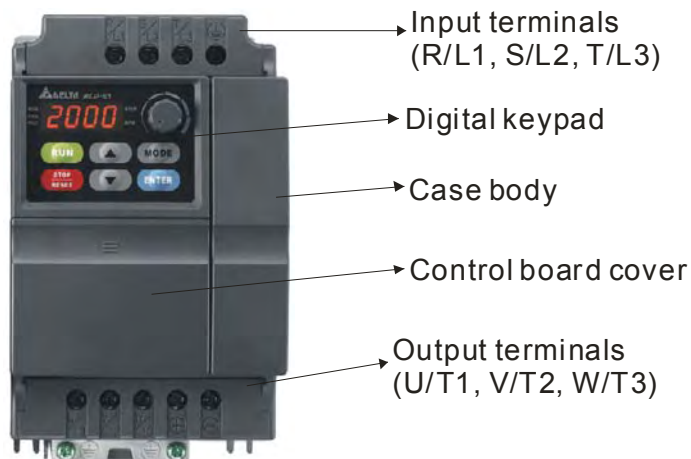

Internal Structure



RFI Jumper Location



 **NOTE**

The RFI jumper of frame A and frame B is beside the input terminals (R/L1, S/L2, T/L3) as circled in above picture and can be removed by loosening the screws.

Frame	Power range	Models
A	0.25-2hp (0.2-1.5kW)	BLD002E111A/121A/123A, BLD004E111A/121A/123A/143 A, BLD007E121A/123A/143A, BLD015E123A/143A
B	1-5hp (0.75-3.7kW)	BLD007E111A , BLD015E121A, BLD022E121A /123A/143A, BLD037E123A/143A

RFI Jumper

RFI Jumper: The brushless DC motor drive may emit the electrical noise. The EMI (electromagnetic interference with standard Y capacity) is used to suppress the interference (Radio Frequency Interference) on the power line. As the leakage current will be increased after using with EMI, user can cut off the RFI when reducing the leakage current is required.

Main power isolated from earth:

If the brushless DC motor drive is supplied from an isolated power (IT power), the RFI jumper must be cut off. Then the RFI capacities (filter capacitors) will be disconnected from ground to prevent circuit damage (according to IEC 61800-3) and reduce earth leakage current.



CAUTION!

1. After applying power to the brushless DC motor drive, do not cut off the RFI jumper. Therefore, please make sure that main power has been switched off before cutting the RFI jumper.
2. The gap discharge may occur when the transient voltage is higher than 1,000V. Besides, electro-magnetic compatibility of the brushless DC motor drives will be lower after cutting the RFI jumper.
3. Do NOT cut the RFI jumper when main power is connected to earth.
4. The RFI jumper cannot be cut when Hi-pot tests are performed. The mains power and motor must be separated if high voltage test is performed and the leakage currents are too high.
5. To prevent drive damage, the RFI jumper connected to ground shall be cut off if the brushless DC motor drive is installed on an ungrounded power system or a high impedance grounding (over 30 ohms) power system or a corner grounded TN system.

About Grounding System

According to international standard IEC60364, the grounding system can be divided as follows:

1. The first letter: the connection between grounded point and power equipment (generator or transformer)
 - T: connect to the same grounded point directly, I: NOT connect to the grounded point (insulation) or grounded via high-resistance equipment.
2. The second letter: connection method between grounded point and the electrical device being supplied
 - T: connect to grounded point, independent of other power supplied grounded point, N: grounded via the power supply system
3. The third and fourth letter: position of grounded conductor
 - S: neutral and grounded point are disconnection, C: neutral is connected to grounded point in parallel

TN-S grounding system:

TN-S is a grounding system with 3-phase, 4-line and PE line. The feature of TN-S system is the neutral line and protective earth(PE) line have an only common grounding at the neutral point of transformer. The neutral line (N) is live part and PE line is NOT live part. This grounding system equips safe and reliable basic potential.

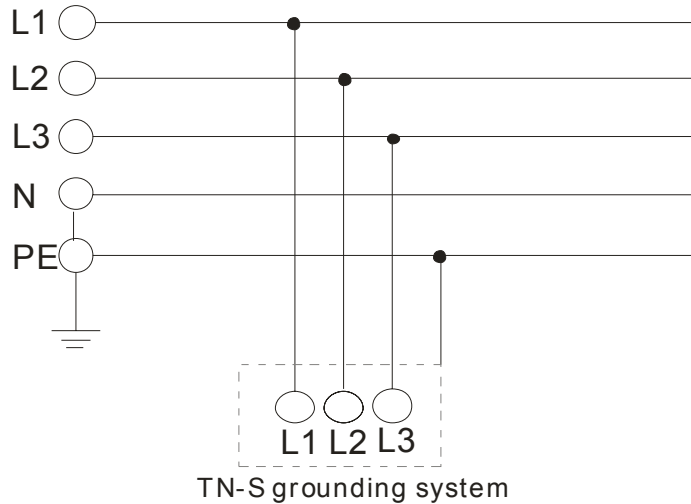

TN-C grounding system:

TN-C grounding system is called 3-phase and 4-line system. This system combines the neutral line with protective earthing(PE) and is called PEN line. This grounding system is sensitive to the grounding malfunction with simple wiring but it is only suitable for the occasions with balanced 3-phase overload. If the high harmonic current caused by the unbalanced current of PEN line and other power electronic equipment superposes on the neutral line in the normal situation and makes the neutral line to be live part with unstable current, it will cause unstable neutral grounding potential. Moreover, it will also make the equipment case connected with PEN line be live part to result in personal injury and incorrect accurate electronic equipment operation (can't get a suitable potential base point).

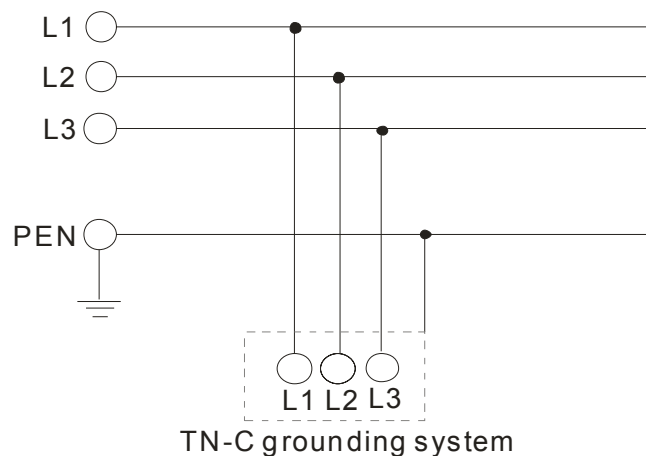

TN-C-S grounding system:

TN-C-S grounding system is made up of two grounding systems, including TN-C system and TN-S system. The connection point of these two systems is at the connection point of N line and PE line.

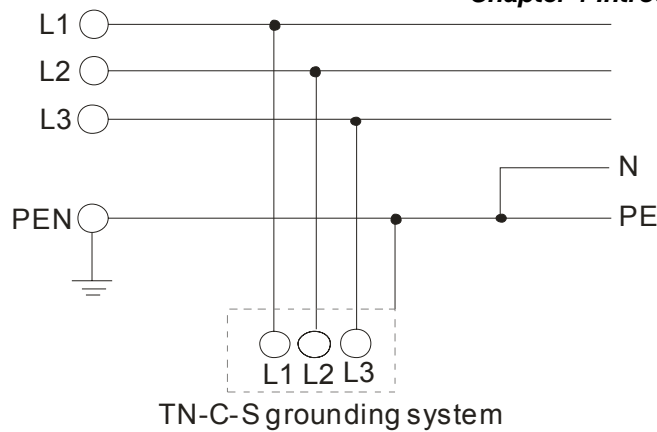

TT grounding system:

TT grounding system is usually called 3-phase 4-line grounding system. The feature of TT grounding system is no electrical connection between the neutral line and protective earthing, i.e. the grounding of the neutral and PE line is separated. No matter 3-phase load is balanced or not, the PE line won't be live part as the neutral line is live part when this system is in normal operation. When only 1-phase grounding is fault, the fault can't be stopped immediately due to the low sensitive of protective earthing and only equipment case may be live part.

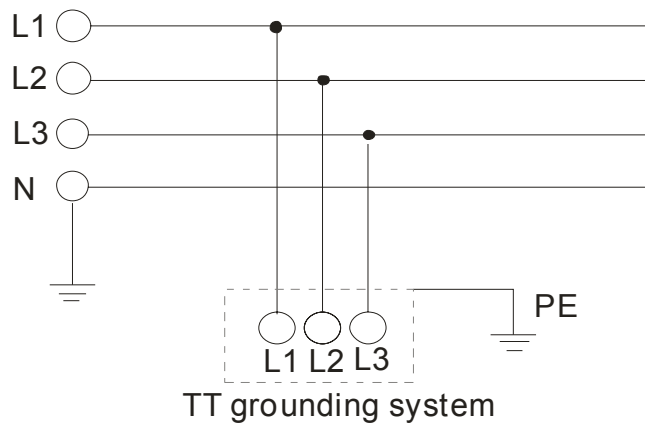

IT grounding system:

IT grounding system is a 3-phase 3-line grounding system. The neutral of the system transformer is not grounded or grounded by the impedance, no neutral line N and protective earthing is grounded separately. The advantage of this system is that when only one phase is grounded, it won't cause greater current in the case and the system will operate normally.

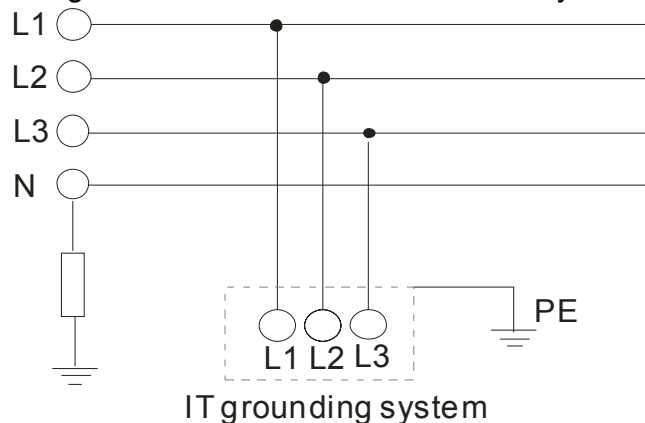

1.1.5 Remove Instructions

Remove Front Cover



Step 1

Step 2

Remove Fan

For Frame A and Frame B, press and hold in the tabs on each side of the fan and pull the fan up to release.



1.2 Preparation for Installation and Wiring

1.2.1 Ambient Conditions

Install the brushless DC motor drive in an environment with the following conditions:

Operation	Air Temperature	-10 ~ +40°C (14~104°F) for UL & cUL -10 ~ +30 °C (14~86°F)for side-by-side mounting
	Relative Humidity	<90%, no condensation allowed
	Atmosphere pressure	86 ~ 106 kPa
	Installation Site Altitude	<1000m
	Vibration	<20Hz: 9.80 m/s ² (1G) max 20 ~ 50Hz: 5.88 m/s ² (0.6G) max
Storage Transportation	Temperature	-20°C ~ +60°C (-4°F ~ 140°F)
	Relative Humidity	<90%, no condensation allowed
	Atmosphere pressure	86 ~ 106 kPa
	Vibration	<20Hz: 9.80 m/s ² (1G) max 20 ~ 50Hz: 5.88 m/s ² (0.6G) max
Pollution Degree	2: good for a factory type environment.	

Minimum Mounting Clearances

Frame A Mounting Clearances

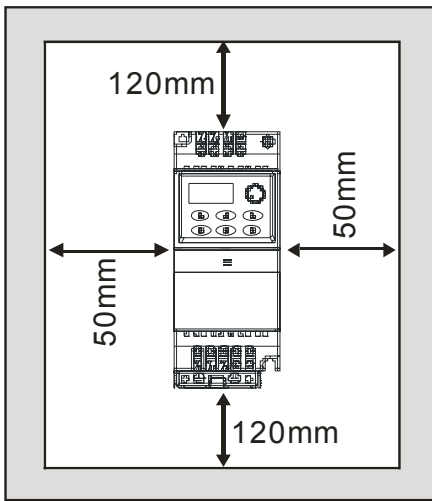

single drive

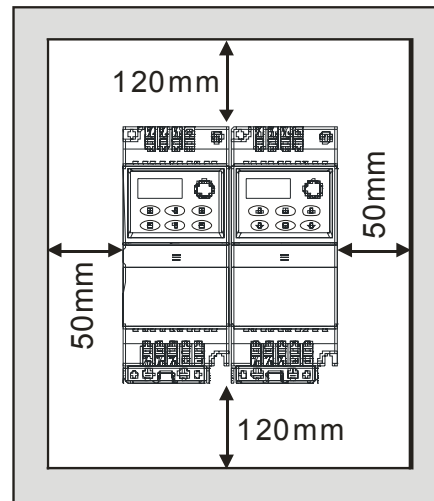

side-by-side installation

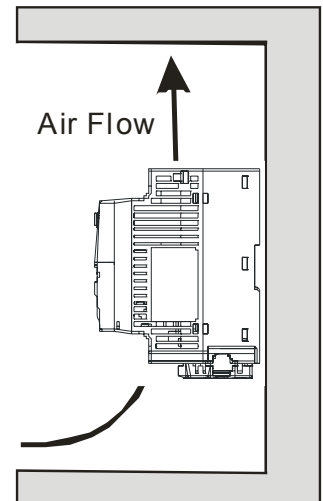

air flow

Frame B Mounting Clearances

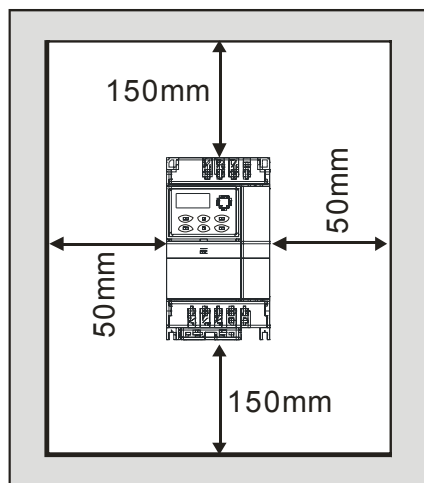

single drive

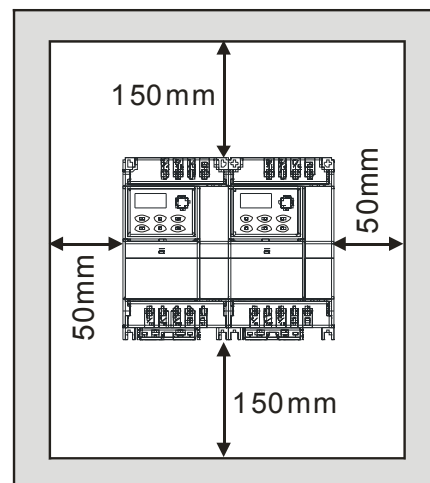

side-by-side installation

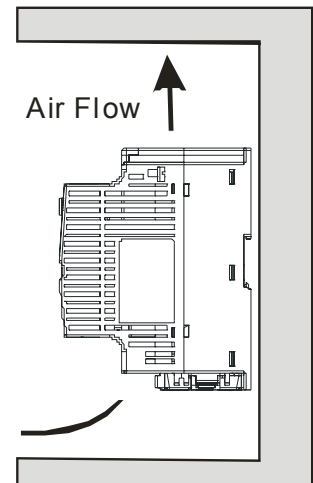

air flow



CAUTION!

1. Operating, storing or transporting the brushless DC motor drive outside these conditions may cause damage to the brushless DC motor drive.
2. Failure to observe these precautions may void the warranty!
3. Mount the brushless DC motor drive vertically on a flat vertical surface object by screws. Other directions are not allowed.
4. The brushless DC motor drive will generate heat during operation. Allow sufficient space around the unit for heat dissipation.

5. The heat sink temperature may rise to 90°C when running. The material on which the brushless DC motor drive is mounted must be noncombustible and be able to withstand this high temperature.
6. When brushless DC motor drive is installed in a confined space (e.g. cabinet), the surrounding temperature must be within 10 ~ 40°C with good ventilation. DO NOT install the brushless DC motor drive in a space with bad ventilation.
7. When installing multiple brushless DC motor drives in the same cabinet, they should be adjacent in a row with enough space in-between. When installing one brushless DC motor drive below another one, use a metal separation between the brushless DC motor drives to prevent mutual heating.

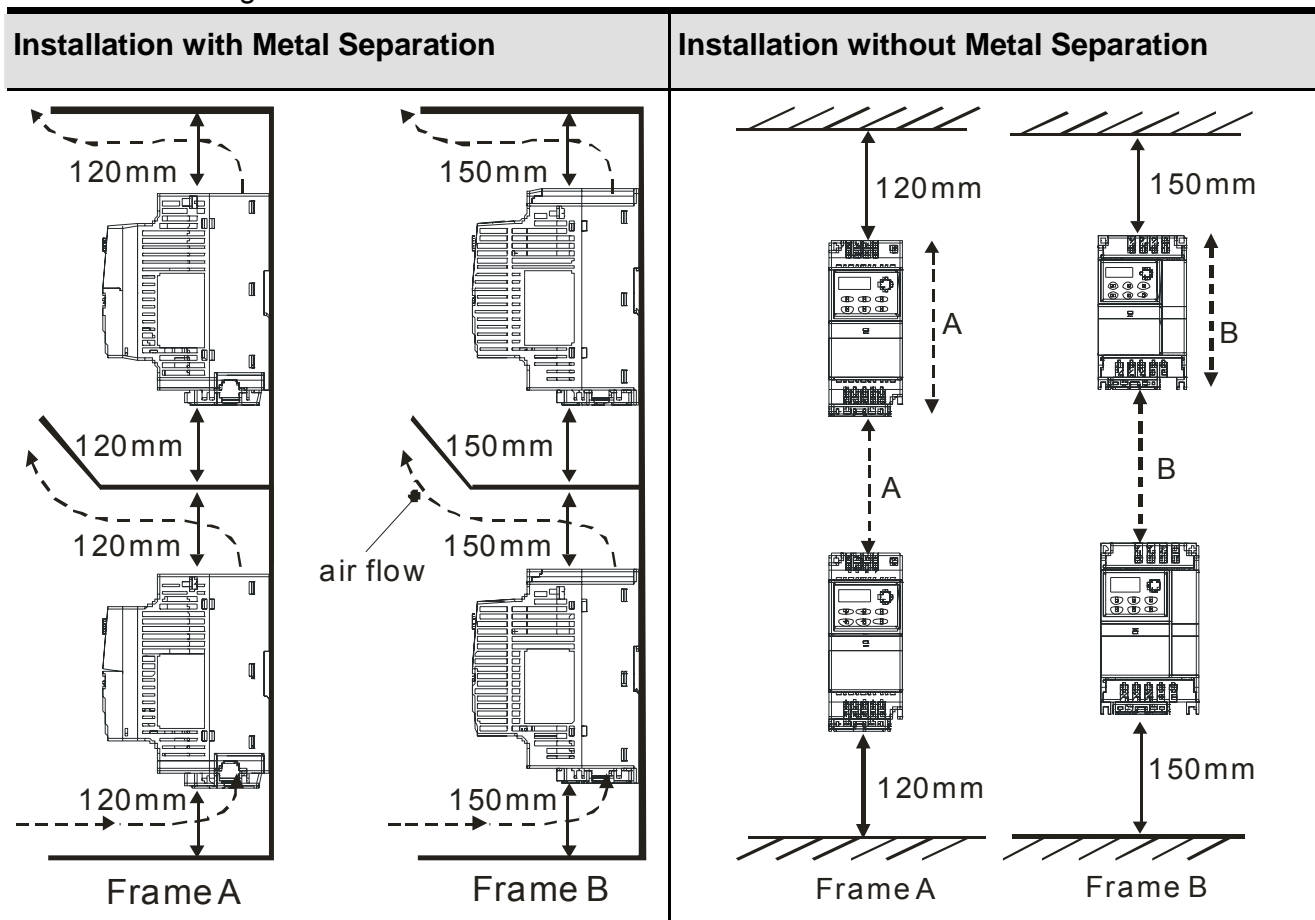

1.2.2 DC-bus Sharing: Connecting the DC-bus of the Brushless DC motor drive in Parallel

1. The brushless DC motor drives can absorb mutual voltage that generated to DC bus when deceleration.
2. Enhance brake function and stabilize the voltage of the DC bus.
3. Only the same capacity and same power system can be connected in parallel.
4. The 5 drives should be in same power system, e.g. if the input voltage is 220V, the 5 brushless DC motor drives connected in parallel must also be 220V.

The power should be applied at the same time (only the same capacity and same power system can be connected in parallel).

Power 208/220/230/380/440/480 (depend on models)

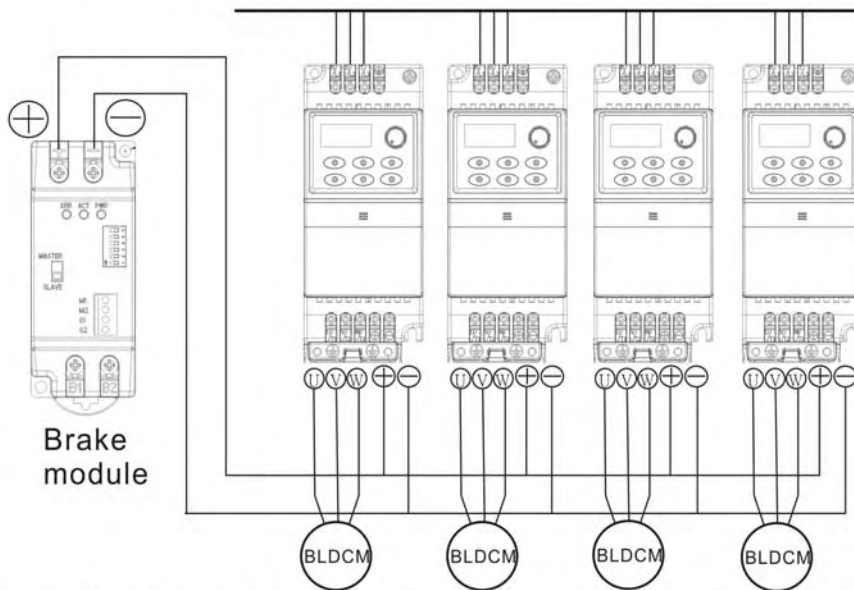

For frame A and frame B, terminal + (-) is connected to the terminal + (-) of the brake module.

 **NOTE**

Prevent fiber particles, scraps of paper, dust, metal particles from adhering to the heatsink.

The material on which the brushless DC motor is mounted must be noncombustible and be able to withstand the high temperature to prevent fire accidents.

The parallel connection of multiple drives is NOT for 115V models.

1.3 Dimensions

(Dimensions are in millimeter and [inch])

Frame A

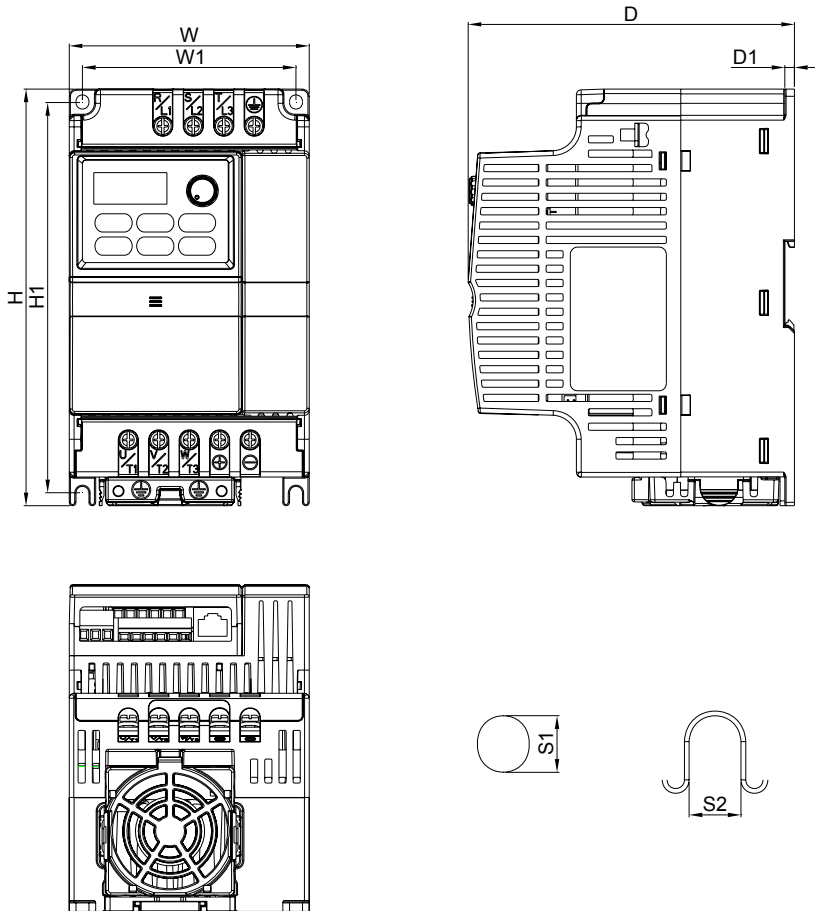

Frame	W	W1	H	H1	D	D1	S1	S2
A	72.0 [2.83]	59.0 [2.32]	174.0 [6.86]	151.6 [5.97]	136.1 [5.36]	4.0 [0.16]	5.4 [0.21]	5.4 [0.21]
B	100.0 [3.94]	89.0 [3.50]	174.0 [6.85]	162.9 [6.42]	136.0 [5.36]	4.0 [0.16]	5.9 [0.23]	5.4 [0.21]

 **NOTE**

Frame A: BLD002E111A/121A/123A, BLD004E111A/121A/123A/143A, BLD007E121A/123A/143A, BLD015E123A/143A

Frame B: BLD007E111A , BLD015E121A, BLD022E121A /123A/143A, BLD037E123A/143A

Chapter 2 Installation and Wiring

After removing the cover of input/output terminals and control terminals, check if terminals are clear. Be sure to observe the following precautions when wiring.



CAUTION!

1. Make sure that power is only applied to the R/L1, S/L2, T/L3 terminals. Failure to comply may result in damage to the equipment. The voltage and current should lie within the range as indicated on the nameplate.
2. All the units must be grounded directly to a common ground terminal to prevent lightning strike or electric shock and also for decreasing the noise interference.
3. Please make sure to fasten the screw of the main circuit terminals to prevent sparks which is made by the loose screws due to vibration.



DANGER!

1. A charge may still remain in the DC bus capacitors with hazardous voltages even if the power has been turned off. To prevent personal injury, please ensure that the power is turned off and wait ten minutes for the capacitors to discharge to safe voltage levels before opening the brushless DC motor drive.
2. Only qualified personnel familiar with brushless DC motor drives is allowed to perform installation, wiring and commissioning.
3. Make sure that the power is off before doing any wiring to prevent electric shock.



CAUTION!

1. Use wire gauges that comply with the local regulations during wiring.
2. Check following items after finishing the wiring:
 - A. Are all connections correct?
 - B. No loose wires?
 - C. No short-circuits between terminals or to ground?

2.1 Wiring

There are main circuit and control circuit for the wiring of the brushless DC motor. Users must connect wires according to the circuit diagrams on the following pages.

Figure 1 for models of BLD-E1 Series

BLD002E111A/121A, BLD004E111A/121A, BLD007E111A/121A, BLD015E121A, BLD022E121A

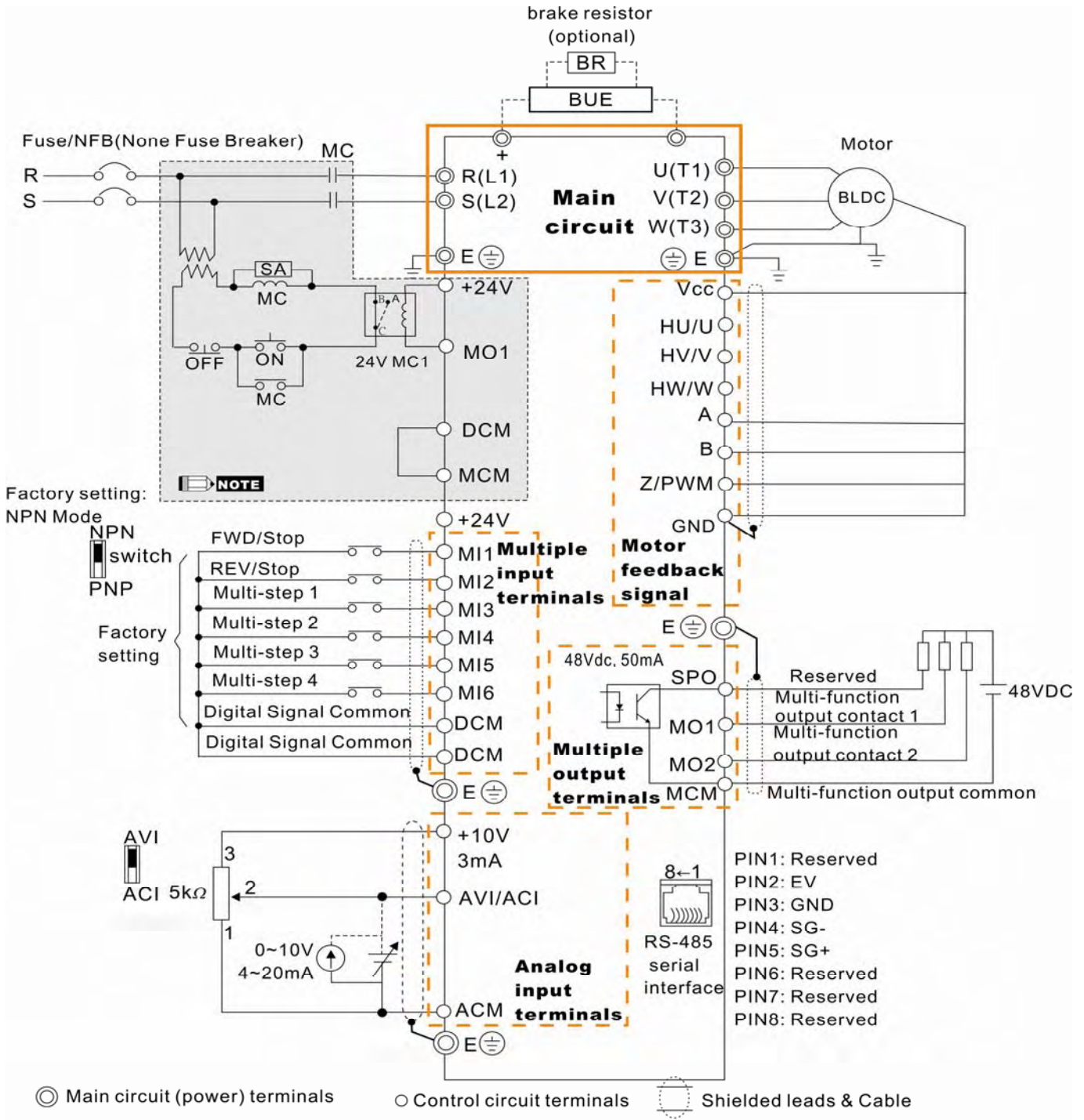
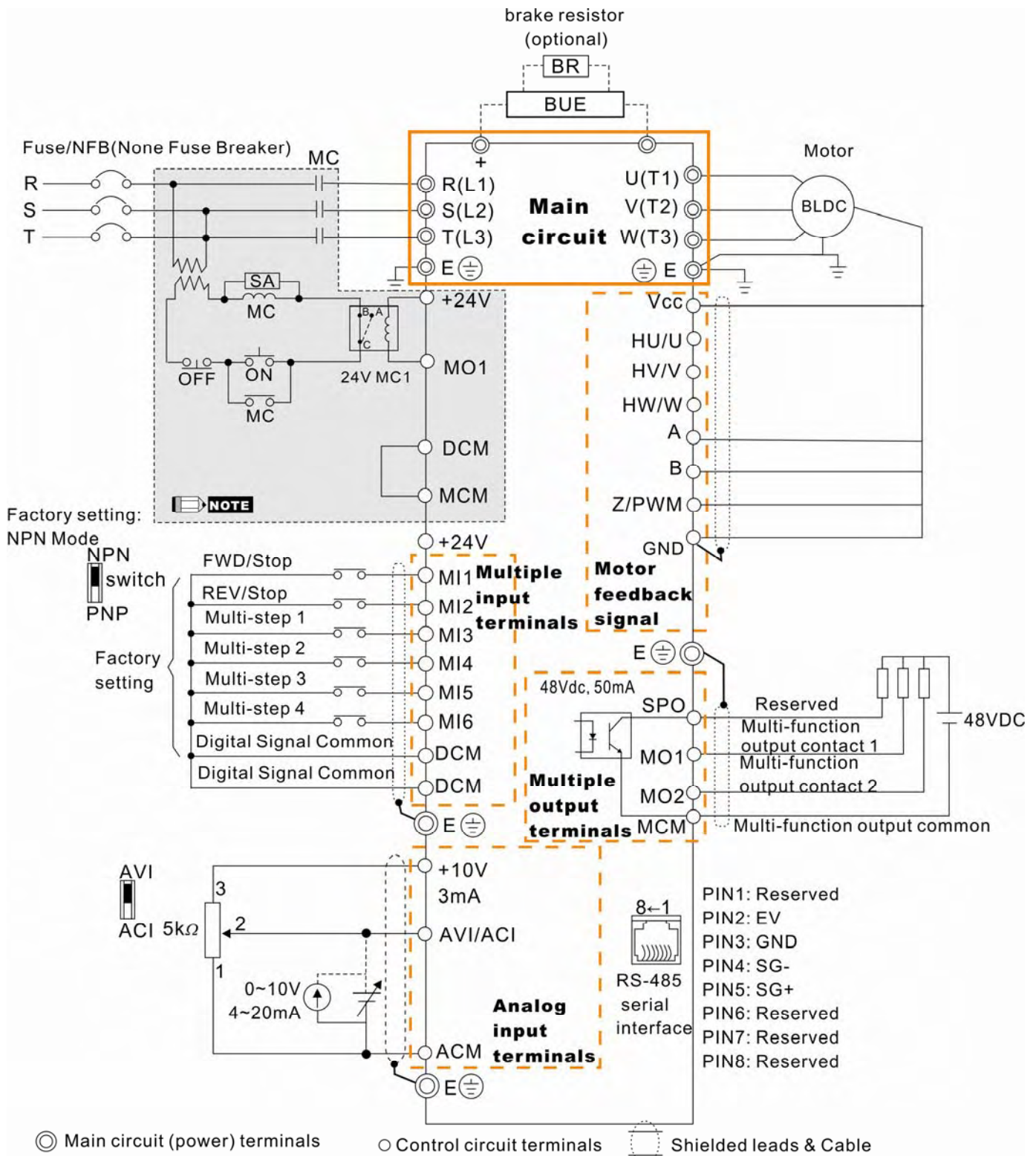

Figure 2 for models of BLD-E1 Series

BLD002E123A, BLD004E123A/143A, BLD007E123A/143A, BLD015E123A/143A, BLD022E123A/143A, BLD037E123A/143A



NOTE

1. It is the recommended circuit between terminals 24V and MO1 when power supply is turned off by a fault output. This protection circuit will turn on the contact of multi-function output terminals to turn off the power and protect the power system.
2. Please connects phase U/V/W individually to terminal U(T1)/V(T2)/W(T3) in order to prevent overheat and overspeed of motor and to prevent drive damage. Note: The wire color of phase U/V/W for Delta ECMD-E9 Series motor are red/white/black.

Figure 3 Wiring for NPN mode and PNP mode

NPN Mode

Factory setting is NPN

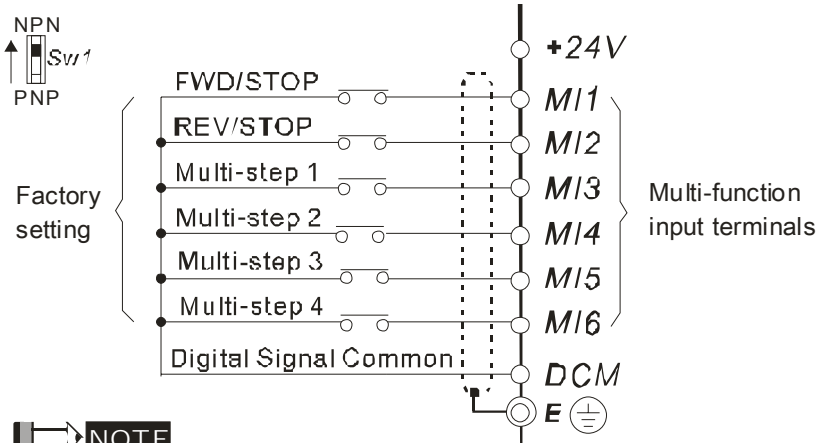

NOTE

Don't apply mains voltage into above terminals.

Applicable Output Signal

Open collector output

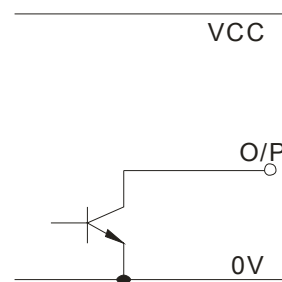

NOTE

It needs to connect O/P to multi-function input terminals for normal operation.

PNP Mode

Factory setting is PNP

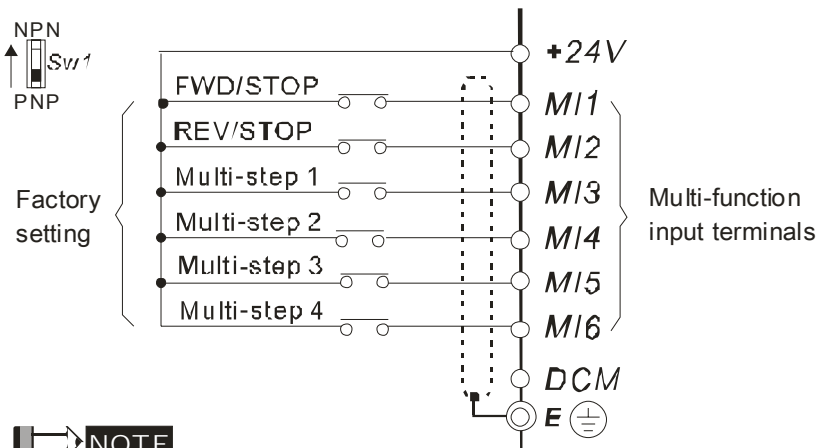

NOTE

Don't apply mains voltage into above terminals.

Applicable Output Signal

Complementary output

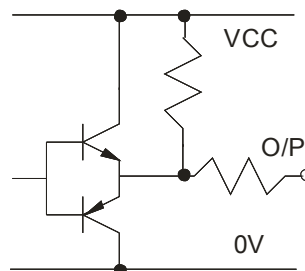

NOTE

It needs to connect O/P to multi-function input terminals for normal operation.

CAUTION!

1. The wiring of main circuit and control circuit should be separated to prevent erroneous actions.
2. Please use shield wire for the control wiring and not to expose the peeled-off net in front of the terminal.
3. Please use the shield wire or tube for the power wiring and ground the two ends of the shield wire or tube.
4. Damaged insulation of wiring may cause personal injury or damage to circuits/equipment if it comes in contact with high voltage.
5. The brushless DC motor drive, motor and wiring may cause interference. To prevent the equipment damage, please take care of the erroneous actions of the surrounding sensors and the equipment.

6. With long motor cables between the brushless DC motor drive and motor, high capacitive switching current peaks can cause over-current, high leakage current or lower current readout accuracy. To prevent this, the motor cable should be less than 20m for 3.7kW models and below. And the cable should be less than 50m for 5.5kW models and above. For longer motor cables use an AC output reactor.
7. The brushless DC motor drive, electric welding machine and the greater horsepower motor should be grounded separately.
8. Use ground leads that comply with local regulations.
9. No brake resistor is built in the BLD-E1 series, it can install brake resistor for those occasions that use higher load inertia or frequent start/stop. Refer to Appendix B for details.
10. To prevent the lightning strike and electric shock, the metal grounding wire of electric equipment should be thick, short and connect to the specific ground terminal of the variable frequency system.
11. Multiple BLD-E1 units can be installed in one location. All the units should be grounded directly to a common ground terminal, as shown in the figure below. **Ensure there are no ground loops.**

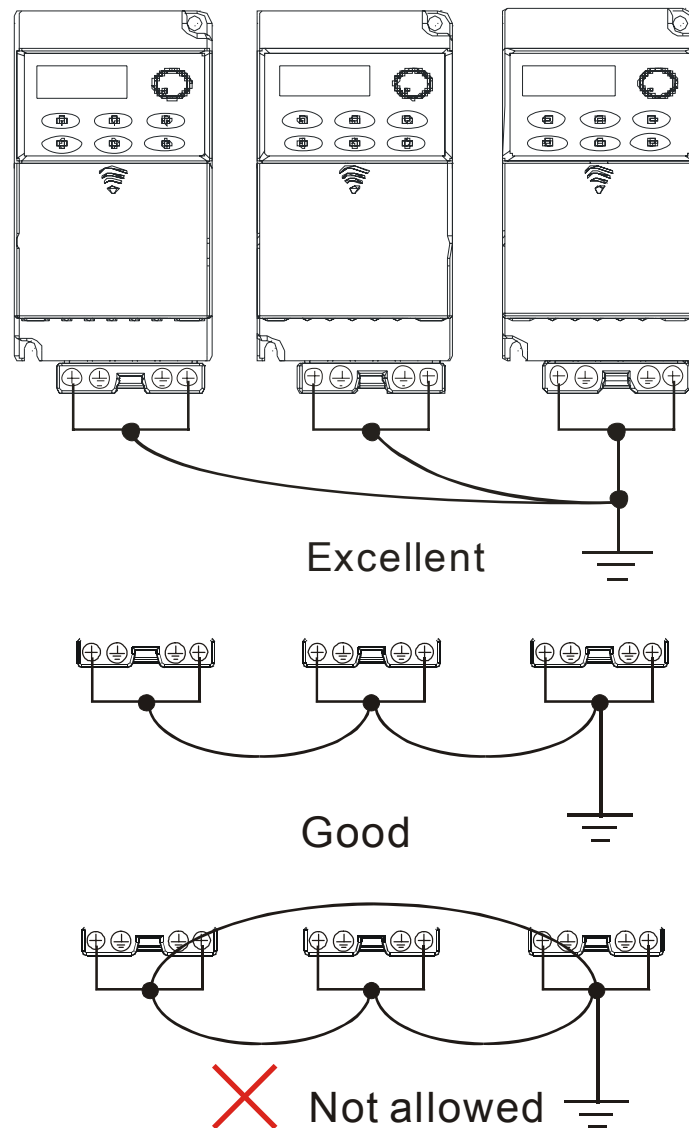

2.2 External Wiring

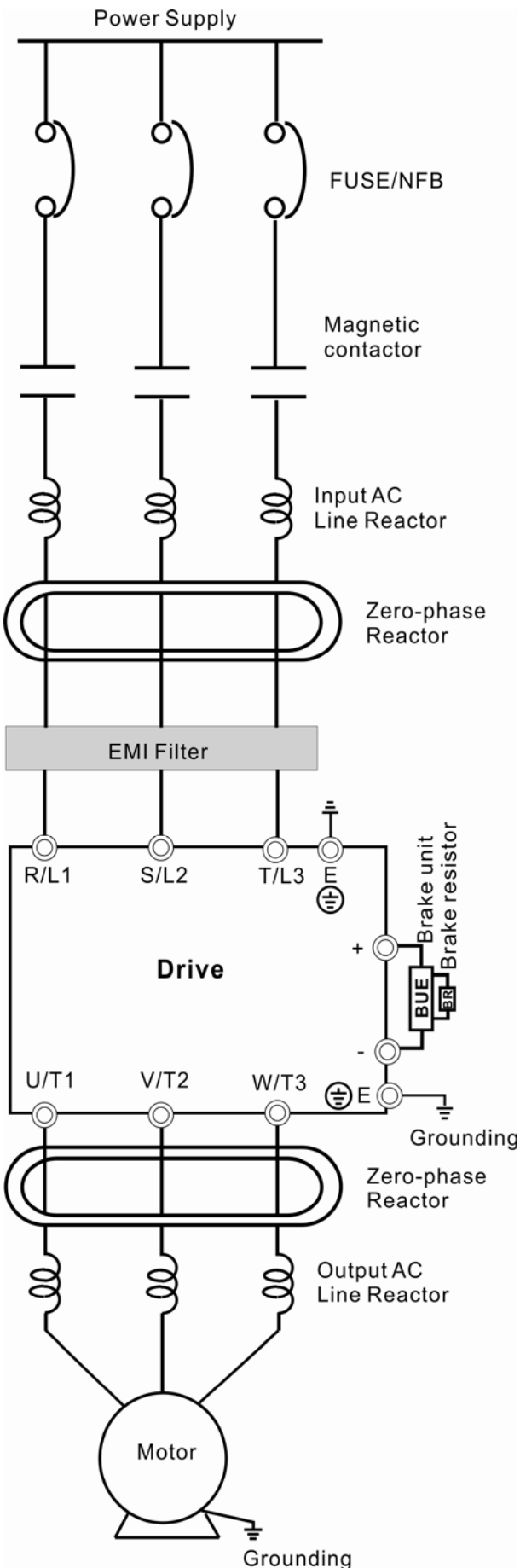

Items	Explanations
Power supply	Please follow the specific power supply requirements shown in Appendix A.
Fuse/NFB (Optional)	There may be an inrush current during power up. Please check the chart of Appendix B and select the correct fuse with rated current. Use of an NFB is optional.
Magnetic contactor (Optional)	Do NOT run/stop brushless DC motor drives by turning the magnetic contactor ON/OFF, as it will reduce the usage life of drive. If you still need to run/stop drives by turning the magnetic contactor ON/OFF, it is recommended to do so only ONCE per hour.
Input AC Line Reactor (Optional)	Used to improve the input power factor, to reduce harmonics and provide protection from AC line disturbances (surges, switching spikes and short interruptions). AC line reactor should be installed when the power supply capacity is 500kVA or more or advanced capacity is activated. The wiring distance should be $\leq 10\text{m}$. Refer to appendix B for details.
Zero-phase Reactor (Ferrite Core Common Choke) (Optional)	Zero phase reactors are used to reduce radio noise especially when audio equipment is installed near the brushless DC motor drive. Effective for noise reduction on both the input and output sides. Attenuation quality is good for a wide range from AM band to 10MHz. Appendix B specifies the zero phase reactor. (RF220X00A)
EMI filter	To reduce electromagnetic interference. It is built in 230V 1-phase and 460V models.
Driver	The surrounding temperature should be within the specification (refer to chapter 1) to prevent from reducing the drive's usage life. Please wire according to chapter 2 wiring, wrong wire may cause damage.
Brake resistor and Brake unit	Used to reduce the deceleration time of the motor. Please refer to the chart in Appendix B for specific Brake resistors.
Output AC Line Reactor	Motor surge voltage amplitude depends on motor cable length. For applications with long motor cable ($>20\text{m}$), it is necessary to install a reactor at the drive output side. Please refer to the chart in appendix B.
Grounding	To prevent electric shock due to leakage current of the drive, the drive and motor should be grounded. Please refer to specification of main circuit terminal.

2.3 Main Circuit

2.3.1 Main Circuit Connection

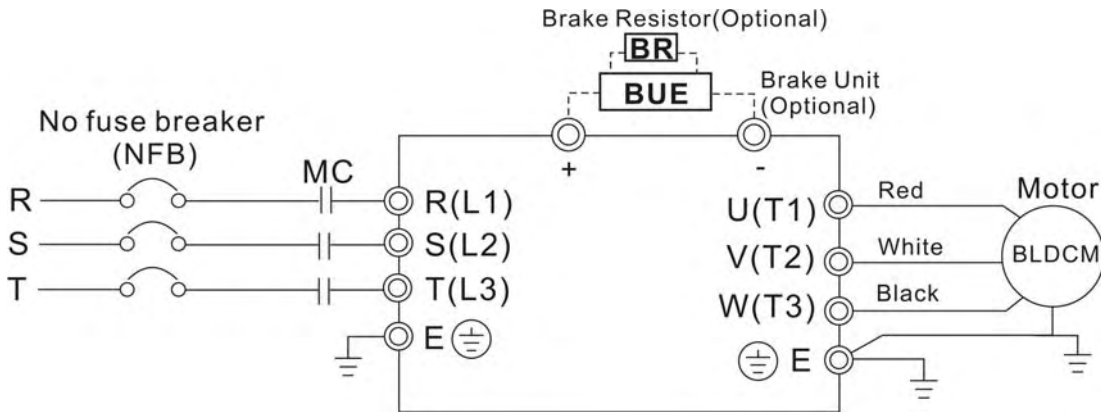

Terminal Symbol	Explanation of Terminal Function
R/L1, S/L2, T/L3	Input terminals of commercial power (1-phase/3-phase)
U/T1, V/T2, W/T3	Output terminals of brushless DC motor drive for connecting brushless DC motor. Wire: U/T1 (Red); V/T2 (White); W/T3 (Black)
+, -	Connections for External Brake unit (BUE series)
 E	Earth connection, please comply with local regulations.



Mains power terminals (R/L1, S/L2, T/L3)

- DO NOT apply 1-phase power to 3-phase models. It is unnecessary to consider phase-sequence of these mains power terminals (R/L1, S/L2, T/L3).
- To connect a no fuse switch between 3-phase AC input power and main circuit terminals (R/L1, S/L2, T/L3) is necessary. It is recommended to add a magnetic contactor (MC) in the power input wiring to cut off power quickly and reduce malfunction when activating the protection function of brushless DC motor drives. Both ends of the MC should have an R-C surge absorber.
- Please make sure to fasten the screw of the main circuit terminals to prevent sparks which is made by the loose screws due to vibration.
- Please use voltage and current within the regulation shown in Appendix A.

Chapter 2 Installation and Wiring | BLD-E1 Series

- When using a general GFCI (Ground Fault Circuit Interrupter), select a current sensor with sensitivity of 200mA or above, and not less than 0.1-second operation time to avoid nuisance tripping. For the specific GFCI of the brushless DC motor drive, please select a current sensor with sensitivity of 30mA or above.

Output terminals for main circuit (U, V, W)

- The factory setting of the operation direction is forward running.
- When it needs to install the filter at the output side of terminals U/T1, V/T2, W/T3 on the brushless DC motor drive. Please use inductance filter. Do not use advanced capacitors or L-C (Inductance-Capacitance) or R-C (Resistance-Capacitance), unless approved by Delta.
- DO NOT connect advanced capacitors or surge absorbers at the output terminals of brushless DC motor drives.
- Use well-insulated motor, suitable for drive operation.
- When using a general GFCI (Ground Fault Circuit Interrupter), select a current sensor with sensitivity of 200mA or above, and not less than 0.1-second operation time to avoid nuisance tripping. For the specific GFCI of the brushless DC motor drive, please select a current sensor with sensitivity of 30mA or above.

Terminals [+ , -] for connecting brake resistor

- Connect a brake resistor or brake unit in applications with frequent decelerations, short deceleration time, insufficient brake torque or requiring increased brake torque.
- When using external brake unit, please connect it to the terminals [+ , -]. Please do NOT connect brake resistors to terminals [+ , -] directly, as it may cause damage.
- All BLD-E1 series don't have a built-in brake chopper. Please connect an external optional brake unit (BUE-series) and brake resistor.
- When not used, please leave the terminals [+ , -] open.

2.3.2 Main Circuit Terminals

Frame A

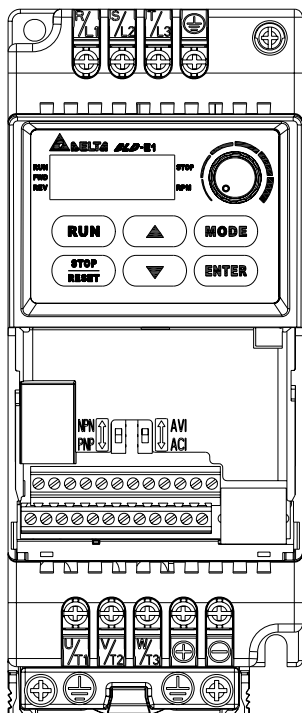

Main circuit terminals:

R/L1, S/L2, T/L3, U/T1, V/T2, W/T3, \oplus , +, -

Models	Wire	Torque	Wire type
BLD002E111A BLD002E121A BLD002E123A	12-18 AWG (3.3- 0.8mm ²)	14-16 kgf-cm (12-14 in-lbf)	Stranded copper Only, 75°C
BLD004E111A BLD004E121A BLD004E123A BLD004E143A			
BLD007E121A BLD007E123A BLD007E143A			
BLD015E123A BLD015E143A			

Frame B

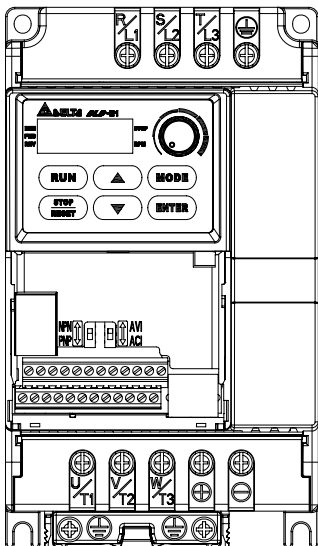

Main circuit terminals:

R/L1, S/L2, T/L3, U/T1, V/T2, W/T3, \oplus , +/B1, B2, -

Models	Wire	Torque	Wire type
BLD007E111A BLD015E121A	8-18 AWG. (8.3- 0.8mm ²)	16-19 kgf-cm (14-17 in-lbf)	Stranded copper Only, 75°C
BLD022E121A BLD022E123A BLD022E143A			
BLD037E123A BLD037E143A			

2.4 Control Terminals

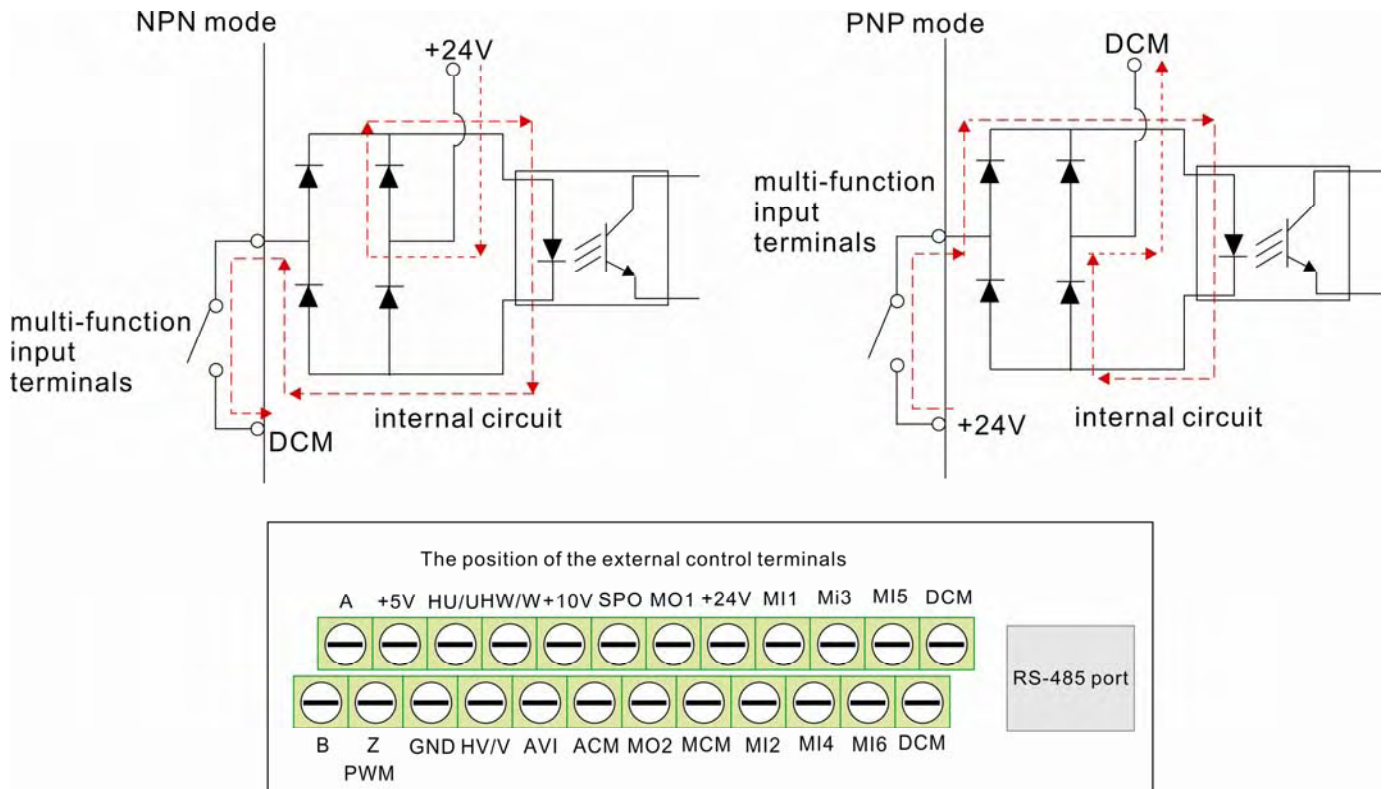

Specification	Torque	Wire
Terminal A, B	2 kgf-cm (2 in-lbf)	16-24 AWG (1.3-0.2mm ²)

Terminal symbols and functions

Terminal Symbol	Terminal Function	Factory Settings (NPN mode) ON: Connect to DCM
MI1	Forward-Stop command	ON: forward running OFF: Ramp to stop
MI2	Reverse-Stop command	ON: reverse running OFF: Ramp to stop
MI3	Multi-function Input 3	Refer to Pr.04-05 to Pr.04-08 for programming the Multi-function Inputs. ON: the activation current is 16mA. OFF: leakage current tolerance is 10μA.
MI4	Multi-function Input 4	
MI5	Multi-function Input 5	
MI6	Multi-function Input 6	

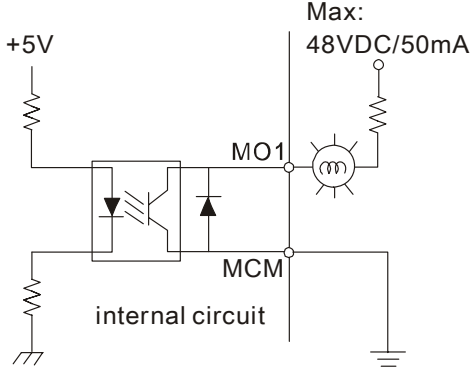
Terminal Symbol	Terminal Function	Factory Settings (NPN mode) ON: Connect to DCM
+24V	DC Voltage Source	+24VDC, 20mA
DCM	Digital Signal Common	Common for digital inputs
HU/U	Reserved	
HV/V	Reserved	
HW/W	Reserved	
A	PG feedback signal contact 1	Sending PG signals to the drive, e.g. activation, operation, speed control etc.
B	PG feedback signal contact 2	Sending PG signals to the drive, e.g. activation, operation, speed control etc.
Z/PWM	PG feedback signal contact PWM	Sending PMW signals to the drive to activate at the origin position.
SPO	Reserved	
+5V	Encoder Power Supply	
GND	Feedback Signal Common	
MO1	Multi-function Output 1 (Photocoupler)	<p>The brushless DC motor monitors all kinds of signal, such as during operation, speed attained and overload indication, by the open collector output. Please refer to Pr.02-13, Pr.02-14 for more details.</p> 
MO2	Multi-function Output 2 (Photocoupler)	
MCM	Multi-function output common (Photocoupler)	Max 48Vdc 50mA
+10V	Potentiometer power supply	Power supply for analog frequency setting +10VDC 3mA (variable resistor 3~5kΩ)

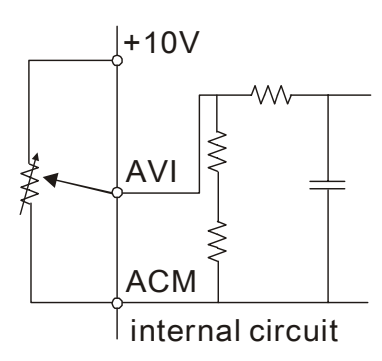
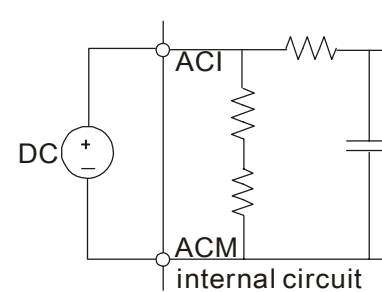
Terminal Symbol	Terminal Function	Factory Settings (NPN mode) ON: Connect to DCM
AVI	Analog voltage Input 	Impedance: 20kΩ Resolution: 10 bits Range: 0 ~ 10VDC = 0 ~ Max. Output Speed (Pr.01-00)
ACI	Analog current Input 	Impedance: 250Ω/100kΩ Resolution: 10 bits Range: 4 ~ 20mA = 0 ~ Max. Output Speed(Pr.01-00)
ACM	Analog control signal (common)	Common for AVI and ACI

NOTE: Control signal wiring size: 18 AWG (0.75 mm²) with shielded wire

Analog inputs (AVI, ACI, ACM)

- Analog input signals are easily affected by external noise. Use shielded wiring and keep it as short as possible (<20m) with proper grounding. If the noise is inductive, connecting the shield to terminal ACM can bring improvement.
- If the analog input signals are affected by noise from the brushless DC motor drive, please connect a capacitor and ferrite core as indicated in the following diagrams:

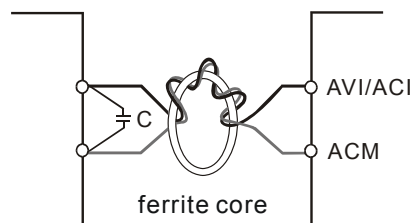

wind each wires 3 times or more around the core

Digital inputs (MI1~MI6, DCM)

- When using contacts to control the digital inputs, please use high quality components to avoid contact bounce.

Digital outputs (MO1, MO2, MCM)

- Make sure to connect the digital outputs to the right polarity, see wiring diagrams.
- When connecting a relay to the digital outputs, connect a surge absorber or fly-back diode across the coil and check the polarity.

This page intentionally left blank

Chapter 3 Keypad and Start Up

3.1 Keypad

3.2 Operation Method

3.3 Trial Run



CAUTION

- Make sure that the wiring is correct. In particular, check that the output terminals U/T1, V/T2, W/T3 are NOT connected to power and that the drive is well grounded.
- Verify that no other equipment is connected to the motor.
- Do NOT operate the brushless DC motor drive with humid hands.
- Check if it displays 2000.0 on the digital keypad after power is applied.



WARNING

- It should be stopped when fault occurs during running and refer to “Fault Code Information and Maintenance” for solution. Please do NOT touch output terminals U, V, W when power is still applied to L1/R, L2/S, L3/T even when the brushless DC motor drive has stopped. It may cause electric shock if touching the output terminals U, V, W.

3.1 Keypad



- ① Status Display
Display the driver's operation status.
- ② LED Display
Indicate speed, voltage, current and user defined units.
- ③ Potentiometer
For master speed setting.
- ④ RUN Key
Start operation
- ⑤ UP and DOWN Key
Set the parameter number and change the numerical data, such as master speed.
- ⑥ MODE
Change between different display mode.
- ⑦ STOP/RESET
Stop operation and reset the drive after fault occurred.

There are five indications on the keypad:















STOP **Stop indicator: it will light up when the motor is stop**

RUN **RUN indicator: it will light up when the motor is running**

FWD **Forward indicator: it will light up when the motor runs in forward direction**

REV **Reverse indicator: it will light up when the motor runs in reverse direction**

RPM **Speed indicator: it will light up when the speed is setting or outputting**

Display Message	Descriptions
	Displays the master speed of the drive and RPM signal blinking.
	Displays the actual output speed at terminals U/T1, V/T2, and W/T3.
	User defined unit
	Displays the output current at terminals U/T1, V/T2, and W/T3.
	Displays the brushless DC motor drive forward run status.
	Displays the brushless DC motor drive reverse run status.
	The counter value (C).
	Speed is controlled by current setting.
	Speed is controlled by potentiometer and operation is controlled by the digital keypad.
	Displays the selected parameter.
	Displays the actual stored value of the selected parameter.
	External Fault.
	Display "End" for approximately 1 second if input has been accepted and automatically stored in memory.
	Display "Err", if the input is invalid.

3.1.1 How to Operate the Digital Keypad

The setting values in the following diagram are only example. Please regards the setting value according to BLD-E1 Series.

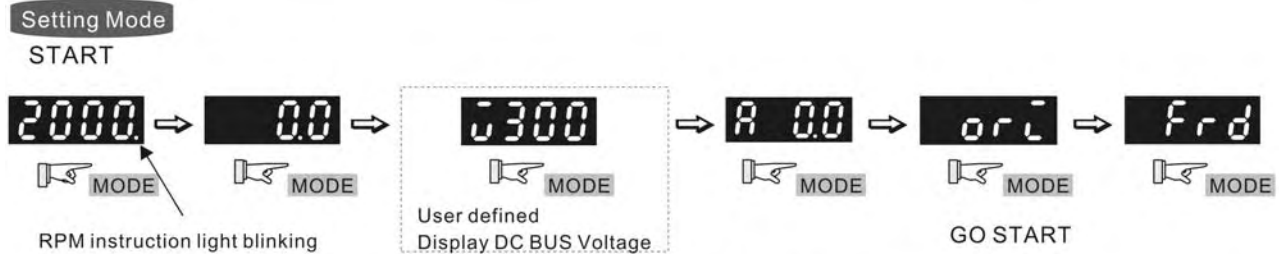

NOTE: In the selection mode, press **MODE** to set the parameters.

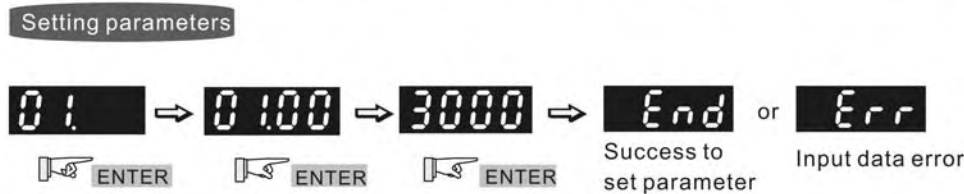

NOTE: In the parameter setting mode, you can press **MODE** to return the selecting mode.

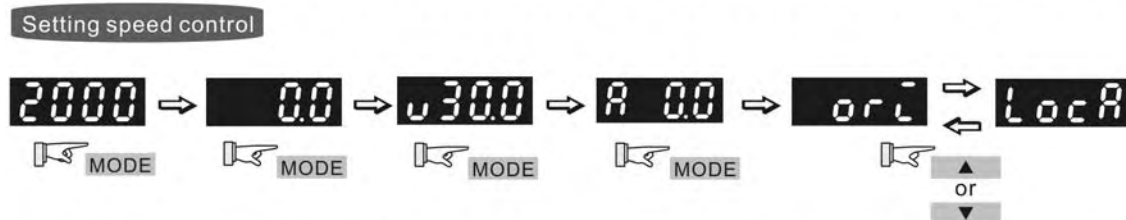
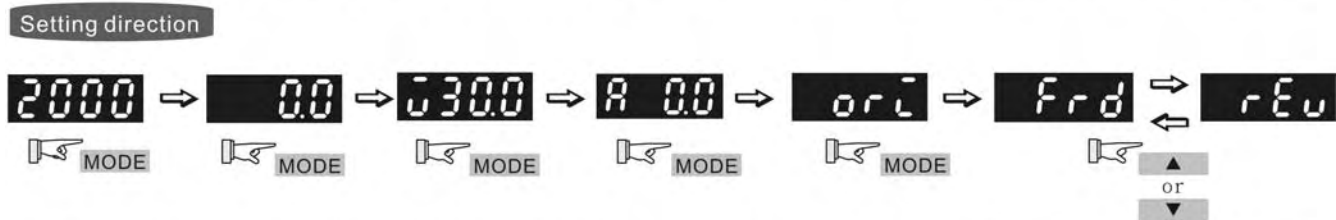
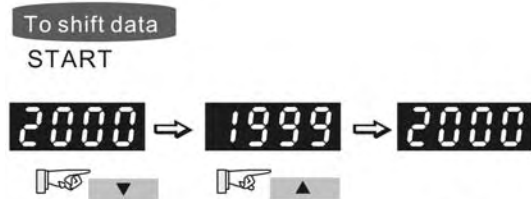

NOTE: If you set to **orL**, speed and operation will be controlled by the current setting.

If you set to **LocA**, speed will be controlled by VR and operation will be controlled
By the digital keypad.

Reference Table for the 7-segment LED Display of the Digital Keypad

Digit	0	1	2	3	4	5	6	7	8	9
LED Display										
ASCII	0x30	0x31	0x32	0x33	0x34	0x35	0x36	0x37	0x38	0x39
Digit	A	b	Cc	d	E	F	G	Hh	i	Jj
LED Display										
ASCII	0x41	0x62	0x43,0x63	0x64	0x45	0x46	0x47	0x48,0x68	0x69	0x4a,0x6a
Digit	K	L	n	o	P	q	r	S	t	Uu
LED Display										
ASCII	0x4b	0x4c	0x6e	0x6f	0x50	0x71	0x72	0x53	0x74	0x55,0x75
Digit	v	Y	Z							
LED Display										
ASCII	0x76	0x59	0x5a							
Digit	A.	b.	C.c	d.	E.	F.	G.	H.h	i.	J.j
LED Display										
ASCII	0xb0	0xb1	0xb2,0xb3	0xb4	0xb5	0xb6	0xb7	0xb8,0xb9	0xba	0xbb,0xbc
Digit	K.	L.	n.	o.	P.	q.	r.	S.	t.	U.u
LED Display										
ASCII	0xbd	0xbe	0xbf	0xc0	0xc1	0xc2	0xc3	0xc4	0xc5	0xc6,0xc7
Digit	v.	Y.	Z.							
LED Display										
ASCII	0xc8	0xc9	0xca							

3.2 Operation Method

The operation method can be set via communication and control terminals.



Operation Method	Frequency Source	Operation Command Source
Operate from the communication	When setting communication by the PC, it needs to use VFD-USB01 or IFD8500 converter to connect to the PC. Refer to the communication address 2000H and 2101H setting for details.	
Operate from the digital keypad	<div style="text-align: center;">  </div> <p style="text-align: center;">Figure 3-1</p> <div style="display: flex; justify-content: space-around;"> Potentiometer RUN, STOP/RESET </div>	

Operation Method	Frequency Source	Operation Command Source
<p>Operate from external signal</p>	<p>Factory setting: NPN Mode NPN PNP</p> <p>Factory setting: ACI Mode AVI ACI ACI/AVI switch Factory setting is ACI</p> <p>* Don't apply the mains voltage directly to above terminals.</p> <p>Figure 3-1</p>	<p>+24V</p> <p>MI1</p> <p>MI2</p> <p>MI3</p> <p>MI4</p> <p>MI5</p> <p>MI6</p> <p>Multi-function input terminals</p> <p>DCM</p> <p>E</p> <p>+10V Power supply +10V 20mA</p> <p>AVI Master Frequency 0 to 10V 47KΩ</p> <p>ACI/AVI 4-20mA/0-10V</p> <p>ACM</p> <p>Analog Signal Common</p>
	<p>MI3-DCM (Set Pr.04-05=d10)</p> <p>MI4-DCM (Set Pr.04-06=d11)</p>	<p>MI1-DCM (FWD/STOP)</p> <p>MI2-DCM(REV/STOP)</p>

3.3 Trial Run

The factory setting of trial run is by the potentiometer, please operate by the following steps.

1. After applying the power, setting the parameter according to the motor type in parameter group 08. (For Delta's ECMD-E9 Series of motor, the drive will auto set the motor parameter to the default value)
2. Please execute angle detection for the first time operation of Delta ECMD-E9 Motor and drive. First set 08-00=1 and press RUN, the keypad will show "tun" during the angle detection. The keypad will return to the main menu after the auto-detection is finished.
3. Verify that LED display shows 0~3000RPM (depends on the potentiometer position) with RPM signal blinking and FWD indicator lighted on.
4. Please set potentiometer to a low running speed around 100RPM.
5. Press RUN key for forward running. For ramp to stop, please press STOP/RESET key.
6. To switch to reverse running, press the MODE key and look for FWD page, then press UP/DOWN key to REV page to finish setting.
7. Check following items:
 - Check if the direction of motor rotation is correct.
 - Check if the motor runs steadily without abnormal noise and vibration.
 - Check if acceleration and deceleration are smooth.

If the results of trial run are normal, please start the formal run.

Chapter 4 Parameters

The BLD-E1 parameters are divided into 14 groups by property for easy setting. In most applications, the user can finish all parameter settings before start-up without the need for re-adjustment during operation.

4.1 Summary of Parameter Setting

00 : System Parameter

01 : Basic Parameters

02 : Digital Input/Output Parameters

03 : Analog Input/Output Parameter

04 : Multi-Step Speed Parameters

05 : IM Parameters

06 : Protection Parameters

07 : Special Parameters

08 : PM Parameters

09 : Communication Parameters

10 : Speed Feedback Control Parameters

11 : Advanced Parameters

12 : User-defined Parameters

13 : View User-defined Parameters

4.2 Description of Parameter Setting

00 : System Parameter

01 : Basic Parameters

02 : Digital Input/Output Parameters

03 : Analog Input/Output Parameter

04 : Multi-Step Speed Parameters

05 : IM Parameters

06 : Protection Parameters

07 : Special Parameters

08 : PM Parameters

09 : Communication Parameters

10 : Speed Feedback Control Parameters

11 : Advanced Parameters

12 : User-defined Parameters

13 : View User-defined Parameters

4.1 Summary of Parameter Settings

Group 00 System Parameters

↗: The parameter can be set during operation.

Parameter	Explanation	Settings	Factory Setting	VF	VFPG	FOCPM
00.00	Identity Code of the Brushless DC Motor Drive	0 : 115V,1PH,0.2KW,1/4HP 2 : 115V,1PH,0.4KW,1/2HP 4 : 115V,1PH,0.7KW,1HP 0 : 230V,1PH,0.2KW,1/4HP 2 : 230V,1PH,0.4KW,1/2HP 4 : 230V,1PH,0.7KW,1HP 6 : 230V,1PH,1.5KW,2HP 8 : 230V,1PH,2.2KW,3HP 0 : 230V,3PH,0.2KW,1/4HP 2 : 230V,3PH,0.4KW,1/2HP 4 : 230V,3PH,0.7KW,1HP 6 : 230V,3PH,1.5KW,2HP 8 : 230V,3PH,2.2KW,3HP 10 : 230V,3PH,3.7KW,5HP 3 : 460V,3PH,0.4KW,1/2HP 5 : 460V,3PH,0.7KW,1HP 7 : 460V,3PH,1.5KW,2HP 9 : 460V,3PH,2.2KW,3HP 11 : 460V,3PH,3.7KW,5HP	Read-only	<input type="radio"/>	<input type="radio"/>	<input type="radio"/>
00.01	Rated Current Display of the Brushless DC Motor Drive	Display according to the model series	Read-only	<input type="radio"/>	<input type="radio"/>	<input type="radio"/>
00.02	Parameter Reset	0 : No function 10 : All parameters are reset to factory settings	0	<input type="radio"/>	<input type="radio"/>	<input type="radio"/>
↗00.03	Start-up Display Selection	0 : Frequency command 1 : Out put frequency 2 : DC BUS voltage 3 : Output current 4 : output voltage	0	<input type="radio"/>	<input type="radio"/>	<input type="radio"/>

Parameter	Explanation	Settings	Factory Setting	VF	VFPF	FOCPM
		5 : defined by user (Pr.00-04)				
↗00.04	Content of Multi-function Display	0 : Display the output current from drive to motor 1 : Reserved 2 : Display actual output frequency 3 : Display DC-Bus voltage (U) 4 : Display output voltage of U, V, W (E) 5 : Display output power factor angle (n.) 6 : Display output power (kW) 7 : Display actual motor speed in rpm (HU) 8 : Display estimate output torque (%) 9 : Display PG feedback 10 : Display the electrical angle of drive output 11 : Display the signal value % of VR analog input terminal 12 : Display the signal value % of ACI analog input terminal 13 : Display the signal value % of AVI analog input terminal 14 : Reserved 15 : Display IGBT temperature °C 16 : Digital input status ON/OFF 17 : Digital output status ON/OFF 18 : Multi-step speed (S) 19 : The corresponding CPU pin status of digital input 20 : The corresponding CPU pin status of digital output 21~23 : Reserved 24 : Output AC voltage when	0	<input type="radio"/>	<input type="radio"/>	<input type="radio"/>

Parameter	Explanation	Settings	Factory Setting	VF	VFPG	FOCPM
		malfunction 25 : Output DC voltage when malfunction 26 : Motor frequency when malfunction 27 : Output current when malfunction 28 : Output frequency when malfunction 29 : Frequency command when malfunction 30 : Output power when malfunction 31 : Output torque when malfunction 32 : Input terminal status when malfunction 33 : Output terminal status when malfunction 34 : Drive status when malfunction				
↗00.05	Reserved					
00.06	Software Version	Read-only	#. #	<input type="radio"/>	<input type="radio"/>	<input type="radio"/>
00.07	Selection of motor stop method	0 : decelerate braking to stop 1 : coast to stop	0	<input type="radio"/>	<input type="radio"/>	<input type="radio"/>
↗00.08	Setting of Motor Running Direction	0 : reverse running allowed 1 : reverse running not allowed 2 : forward running not allowed	0	<input type="radio"/>	<input type="radio"/>	<input type="radio"/>
↗00.09	Control Method	0 : V/Fcontrol 1 : V/Fcontrol + Encoder (VFPG) 8 : FOC PM Control (FOCPM)	8	<input type="radio"/>	<input type="radio"/>	<input type="radio"/>
↗00.10	Speed Unit	0 : Hz 3 : RPM	3	<input type="radio"/>	<input type="radio"/>	<input type="radio"/>
00.11	Reserved					
↗00.12	Carrier Frequency	2~15KHz	8	<input type="radio"/>	<input type="radio"/>	<input type="radio"/>
↗00.13	Auto voltage	0 : Enable AVR	0	<input type="radio"/>	<input type="radio"/>	<input type="radio"/>

Parameter	Explanation	Settings	Factory Setting	VF	VFPG	FOCPM
	Regulation (AVR)	1 : Disable AVR 2 : Disable AVR when deceleration stop				
↗00.14	Source of Frequency Command	0 : Digital keypad input 1 : RS-485 serial communication input 2 : External analog input (Pr.03-00~03-02) 3 : Digital terminals input (Pr.04-00~04-15)	2	<input type="radio"/>	<input type="radio"/>	<input type="radio"/>
↗00.15	Source of Operation Command	0 : Digital keypad input 1 : External terminal operation 2 : RS-485 serial communication input	0	<input type="radio"/>	<input type="radio"/>	<input type="radio"/>

Group 01 Basic Parameters

↗: The parameter can be set during operation.

Parameter	Explanation	Settings	Factory Setting	VF	VFPG	FOCPM
01.00	Maximum Operation Frequency	120~4000RPM (10~400Hz)	3000 (250)	<input type="radio"/>	<input type="radio"/>	<input type="radio"/>
01.01	1st Output Frequency Setting 1 (Base Frequency/ Rated Motor Frequency)	0~400.00Hz	60.00	<input type="radio"/>	<input type="radio"/>	<input type="radio"/>
01.02	1st Output Voltage Setting 1 (Base Voltage/ Rated Motor Voltage)	230V Series : 0.0V~255.0V 460V Series : 0.0V~510.0V	220.0 440.0	<input type="radio"/>	<input type="radio"/>	<input type="radio"/>
01.03	2nd Output Frequency Setting 1	0~400.00Hz	0.50	<input type="radio"/>	<input type="radio"/>	
↗01.04	2nd Output Voltage Setting 1	230V Series : 0.0V~255.0V 460V Series : 0.0V~510.0V	5.0 10.0	<input type="radio"/>	<input type="radio"/>	
01.05	3rd Output Frequency Setting 1	0~400.00Hz	0.50	<input type="radio"/>	<input type="radio"/>	
↗01.06	3rd Output Voltage Setting 1	230V Series : 0.0V~255.0V 460V Series : 0.0V~510.0V	5.0 10.0	<input type="radio"/>	<input type="radio"/>	
01.07	4th Output Frequency Setting 1	0~400.00Hz	0.00	<input type="radio"/>	<input type="radio"/>	
↗01.08	4th Output Voltage Setting 1	230V Series : 0.0V~255.0V 460V Series : 0.0V~510.0V	0.0 0.0	<input type="radio"/>	<input type="radio"/>	
01.09	Start Frequency	0~4000rpm (0~400.00Hz)	6 (0.5)	<input type="radio"/>	<input type="radio"/>	
↗01.10	Output Frequency Upper Limit	0~4000rpm (0~400.00Hz)	3000 (250)	<input type="radio"/>	<input type="radio"/>	<input type="radio"/>
↗01.11	Output Frequency Lower Limit	0~4000rpm (0~400.00Hz)	0 (0.00)	<input type="radio"/>	<input type="radio"/>	<input type="radio"/>
↗01.12	Accel Time 1	0.00~600.00 sec	3.00	<input type="radio"/>	<input type="radio"/>	<input type="radio"/>
↗01.13	Decel Time 1	0.00~600.00 sec	2.00	<input type="radio"/>	<input type="radio"/>	<input type="radio"/>
↗01.14	Accel Time 2	0.00~600.00 sec	3.00	<input type="radio"/>	<input type="radio"/>	<input type="radio"/>
↗01.15	Decel Time 2	0.00~600.00 sec	2.00	<input type="radio"/>	<input type="radio"/>	<input type="radio"/>
↗01.16	Accel Time 3	0.00~600.00 sec	3.00	<input type="radio"/>	<input type="radio"/>	<input type="radio"/>
↗01.17	Decel Time 3	0.00~600.00 sec	2.00	<input type="radio"/>	<input type="radio"/>	<input type="radio"/>

Parameter	Explanation	Settings	Factory Setting	VF	VFPG	FOCPM
↗01.18	Accel Time 4	0.00~600.00 sec	3.00	<input type="radio"/>	<input type="radio"/>	<input type="radio"/>
↗01.19	Decel Time 4	0.00~600.00 sec	2.00	<input type="radio"/>	<input type="radio"/>	<input type="radio"/>
↗01.20	Reserved					
↗01.21	Reserved					
↗01.22	Reserved					
↗01.23	Switch Frequency between 1st/4th Accel/decel	0~4000rpm (0~400.00Hz)	0 (0.00)	<input type="radio"/>	<input type="radio"/>	<input type="radio"/>
↗01.24	S-curve for Acceleration Departure Time S1	0.0~25.0 sec	0.0	<input type="radio"/>	<input type="radio"/>	<input type="radio"/>
↗01.25	S-curve for Acceleration Arrival Time S2	0.0~25.0 sec	0.0	<input type="radio"/>	<input type="radio"/>	<input type="radio"/>
↗01.26	S-curve for Deceleration Departure Time S3	0.0~25.0 sec	0.0	<input type="radio"/>	<input type="radio"/>	<input type="radio"/>
↗01.27	S-curve for Deceleration Arrival Time S4	0.0~25.0 sec	0.0	<input type="radio"/>	<input type="radio"/>	<input type="radio"/>
01.28	Mode Selection when Frequency < Fmin	0 : Output waiting 1 : Zero-speed operation 2 : Fmin (4 th output frequency setting)	0	<input type="radio"/>	<input type="radio"/>	
↗01.29	Switch Frequency form S to S5	0~4000rpm (0~400.00Hz)	0 (0.00)	<input type="radio"/>	<input type="radio"/>	<input type="radio"/>
↗01.30	S-curve for Deceleration Arrival Time S5	0.0~25.0 sec	0.0	<input type="radio"/>	<input type="radio"/>	<input type="radio"/>
↗01.31	Time required for deceleration to stop	0.00~600.00 sec	2.00	<input type="radio"/>	<input type="radio"/>	<input type="radio"/>

NOTE: With Delta ECMD-E9 Series motor, rated frequency is 2000rpm and maximum frequency is 3000rpm.

Group 02 Digital

✎: The parameter can be set during operation.

Parameter	Explanation	Settings	Factory Setting	VF	VFPG	FOCPM
02.00	2-wire/3-wire Operation Control	0 : 2-wire operation mode1, FWD/STOP, REV/STOP 1 : 2-wire mode1, FWD/STOP, REV/STOP (Line Start Lockout) 2 : 2-wire mode2, RUN/STOP, REV/FWD 3 : 2-wire mode2, RUN/STOP, REV/FWD (Line Start Lockout) 4 : 3-wire, 5 : 3-wire (Line Start Lockout).	0	○	○	○
02.01	Multi-Function Command Input (MI3)	0 : no function	1	○	○	○
02.02	Multi-Function Input (MI4)	1 : Multi-step command 1	2	○	○	○
02.03	Multi-Function Command Input (MI5)	2 : Multi-step command 2	3	○	○	○
02.04	Multi-Function Command Input (MI6)	3 : Multi-step command 3	4	○	○	○
		4 : Multi-step command 4		○	○	○
		5 : Reset		○	○	○
		6 : Reserved		○	○	○
		7 : acceleration/deceleration speed inhibit		○	○	○
		8 : the 1st, 2nd acceleration/deceleration time selection		○	○	○
		9 : the 3rd, 4th acceleration/deceleration time selection		○	○	○
		10: EF input (Pr.07-28)		○	○	○
		11: Reserved		○	○	○
	12: Stop output		○	○	○	

Parameter	Explanation	Settings	Factory Setting	VF	VFPG	FOCPM
		13~14: Reserved		○	○	○
		15 : Running speed command from VR		○	○	○
		16 : Running speed command from ACI		○	○	○
		17 : Running speed command from AVI		○	○	○
		18 : Emergency Stop (Pr.07-28)		○	○	○
		19~26 : Reserved		○	○	○
		27 : ASR1/ASR2 Selection		○	○	○
		28 : Emergency stop (EF1) (Motor coasts to stop)		○	○	○
		29~30 : Reserved		○	○	○
		31: High torque bias (by Pr.07-21)		○	○	○
		32: Middle torque bias (by Pr.07-22)		○	○	○
		33: Low torque bias (by Pr.07-23)		○	○	○
		34-37: Reserved		○	○	○
		38: Disable EEPROM write function		○	○	○
		39 : Reserved		○	○	○
		40 : Enable drive to function		○	○	○
02.05 ~ 02.08	Reserved					
↗02.09	Digital Input Response Time	0.001~ 30.000 Sec	0.005	○	○	○
↗02.10	Digital Input Operation Direction	0 ~ 65535	0	○	○	○
02.11	Reserved					

Parameter	Explanation	Settings	Factory Setting	VF	VFPG	FOCPM
02.12	Reserved					
↗02.13	Multi-function Output (MO1)	0 : No function	41	○	○	○
↗02.14	Multi-function Output (MO2)	1: Operation indication	41	○	○	○
		2: Operation speed attained		○	○	○
		3 : Desired frequency attained 1 (Pr. 02-25, 02-26)		○	○	○
		4 : Desired frequency attained 2 (Pr. 02-27, 02-28)		○	○	○
		5: Zero speed (frequency command)		○	○	○
		6: Zero speed with stop (frequency command)		○	○	○
		7: Over torque (OT1) (Pr. 06-05~06-07)		○	○	○
		8: Over torque (OT2) (Pr. 06-08~06-10)		○	○	○
		9: Drive ready		○	○	○
		10 : Low-voltage Detection (LV)		○	○	○
		11 : Malfunction indication		○	○	○
		12 : Reserved		○	○	○
		13 : Overheat warning (Pr. 06-14)		○	○	○
		21 : Ove voltage warning		○	○	○
22 : Over-current stall prevention warning	○	○	○			
23 : Over-voltage stall prevention warning	○	○	○			
24 : Drive operation mode (Parameter: 00.21=0)	○	○	○			

Parameter	Explanation	Settings	Factory Setting	VF	VFPG	FOCPM
		25: Forward running command		<input type="radio"/>	<input type="radio"/>	<input type="radio"/>
		26: Reverse running command		<input type="radio"/>	<input type="radio"/>	<input type="radio"/>
		27~30 : Reserved		<input type="radio"/>	<input type="radio"/>	<input type="radio"/>
		31 : Forward running input		<input type="radio"/>	<input type="radio"/>	<input type="radio"/>
		32 : Reverse running input		<input type="radio"/>	<input type="radio"/>	<input type="radio"/>
		33 : Zero-speed (Actual output frequency)		<input type="radio"/>	<input type="radio"/>	<input type="radio"/>
		34 : Zero speed with Stop (actual output frequency)		<input type="radio"/>	<input type="radio"/>	<input type="radio"/>
		35~39 : Reserved		<input type="radio"/>	<input type="radio"/>	<input type="radio"/>
		40 : Speed attained (including zero speed)		<input type="radio"/>	<input type="radio"/>	<input type="radio"/>
↗02.23	Multi-output Direction	0 ~ 65535	0	<input type="radio"/>	<input type="radio"/>	<input type="radio"/>
02.24	Reserved					
↗02.25	Desired Frequency Attained 1	0 ~ 4000RPM (0.00~400.0Hz)	0 (0.00)	<input type="radio"/>	<input type="radio"/>	<input type="radio"/>
↗02.26	Width of Desired Frequency Attained 1	0 ~ 4000RPM (0.00~400.0Hz)	24 (2.00)	<input type="radio"/>	<input type="radio"/>	<input type="radio"/>
↗02.27	Desired Frequency Attained 2	0 ~ 4000RPM (0.00~400.0Hz)	0 (0.00)	<input type="radio"/>	<input type="radio"/>	<input type="radio"/>
↗02.28	Width of Desired Frequency Attained 2	0 ~ 4000RPM (0.00~400.0Hz)	24 (2.00)	<input type="radio"/>	<input type="radio"/>	<input type="radio"/>

Group 03: Time Parameters

↗: The parameter can be set during operation.

Parameter	Explanation	Settings	Factory Setting	VF	VFPG	FOCPM
↗03.00	Analog Input (VR)	0 : No function	1	<input type="radio"/>	<input type="radio"/>	<input type="radio"/>
↗03.01	Analog Input (ACI)	1 : Frequency command (torque limit under TQR control mode)	0	<input type="radio"/>	<input type="radio"/>	<input type="radio"/>
↗03.02	Analog Input 3 (AVI)	2 : Reserved	0	<input type="radio"/>	<input type="radio"/>	<input type="radio"/>
		3 : Preload input		<input type="radio"/>	<input type="radio"/>	<input type="radio"/>
		4~6 : Reserved		<input type="radio"/>	<input type="radio"/>	<input type="radio"/>
		7: Positive torque limit		<input type="radio"/>	<input type="radio"/>	<input type="radio"/>
		8: Negative torque limit		<input type="radio"/>	<input type="radio"/>	<input type="radio"/>
		9: Regenerative torque limit		<input type="radio"/>	<input type="radio"/>	<input type="radio"/>
		10: Positive/negative torque limit		<input type="radio"/>	<input type="radio"/>	<input type="radio"/>
↗03.03	Analog Input Bias VR	-100.0~100.0%	0.0	<input type="radio"/>	<input type="radio"/>	<input type="radio"/>
↗03.04	Analog Input Bias ACI	-100.0~100.0%	0.0	<input type="radio"/>	<input type="radio"/>	<input type="radio"/>
↗03.05	Analog Input Bias AVI	-100.0~100.0%	0.0	<input type="radio"/>	<input type="radio"/>	<input type="radio"/>
↗03.06	Positive/negative Bias Mode VR	0: Zero bias 1: Serve bias as the center, lower	0	<input type="radio"/>	<input type="radio"/>	<input type="radio"/>
↗03.07	Positive/negative Bias Mode ACI (can be set to 0 or 1 only)	than bias=bias 2: Serve bias as the center, greater than bias=bias 3: The absolute value of the bias	0	<input type="radio"/>	<input type="radio"/>	<input type="radio"/>
↗03.08	Positive/negative Bias Mode AVI	voltage while serving as the center (single polar) 4: Serve bias as the center (single polar)	0	<input type="radio"/>	<input type="radio"/>	<input type="radio"/>
↗03.09	Analog Input Gain VR	0.0~500.0%	100.0	<input type="radio"/>	<input type="radio"/>	<input type="radio"/>
↗03.10	Analog Input Gain ACI	0.0~500.0%	100.0	<input type="radio"/>	<input type="radio"/>	<input type="radio"/>
↗03.11	Analog Input Gain AVI	0.0~500.0%	100.0	<input type="radio"/>	<input type="radio"/>	<input type="radio"/>
↗03.12	Analog Input Delay Time VR	0.00 ~ 2.00 sec	0.05	<input type="radio"/>	<input type="radio"/>	<input type="radio"/>

Parameter	Explanation	Settings	Factory Setting	VF	VFP	FOCPM
↗03.13	Analog Input Delay Time ACI	0.00 ~ 2.00 sec	0.05	<input type="radio"/>	<input type="radio"/>	<input type="radio"/>
↗03.14	Analog Input Delay Time AVI	0.00 ~ 2.00 sec	0.05	<input type="radio"/>	<input type="radio"/>	<input type="radio"/>
↗03.15	Loss of the ACI Signal	0: Disable 1: Continue operation at the last frequency 2: Decelerate to 0Hz 3: Stop immediately and display E.F.	0	<input type="radio"/>	<input type="radio"/>	<input type="radio"/>

Group 04: Multi-Step Speed Parameters

↗: The parameter can be set during operation.

Parameter	Explanation	Settings	Factory Setting	VF	VFPG	FOCPM
↗04.00	Zero Step Speed Frequency	0 ~ 4000RPM (0.00~400.0Hz)	0.00	<input type="radio"/>	<input type="radio"/>	<input type="radio"/>
↗04.01	1st Step Speed Frequency	0 ~ 4000RPM (0.00~400.0Hz)	0.00	<input type="radio"/>	<input type="radio"/>	<input type="radio"/>
↗04.02	2nd Step Speed Frequency	0 ~ 4000RPM (0.00~400.0Hz)	0.00	<input type="radio"/>	<input type="radio"/>	<input type="radio"/>
↗04.03	3rd Step Speed Frequency	0 ~ 4000RPM (0.00~400.0Hz)	0.00	<input type="radio"/>	<input type="radio"/>	<input type="radio"/>
↗04.04	4th Step Speed Frequency	0 ~ 4000RPM (0.00~400.0Hz)	0.00	<input type="radio"/>	<input type="radio"/>	<input type="radio"/>
↗04.05	5th Step Speed Frequency	0 ~ 4000RPM (0.00~400.0Hz)	0.00	<input type="radio"/>	<input type="radio"/>	<input type="radio"/>
↗04.06	6th Step Speed Frequency	0 ~ 4000RPM (0.00~400.0Hz)	0.00	<input type="radio"/>	<input type="radio"/>	<input type="radio"/>
↗04.07	7th Step Speed Frequency	0 ~ 4000RPM (0.00~400.0Hz)	0.00	<input type="radio"/>	<input type="radio"/>	<input type="radio"/>
↗04.08	8th Step Speed Frequency	0 ~ 4000RPM (0.00~400.0Hz)	0.00	<input type="radio"/>	<input type="radio"/>	<input type="radio"/>
↗04.09	9th Step Speed Frequency	0 ~ 4000RPM (0.00~400.0Hz)	0.00	<input type="radio"/>	<input type="radio"/>	<input type="radio"/>
↗04.10	10th Step Speed Frequency	0 ~ 4000RPM (0.00~400.0Hz)	0.00	<input type="radio"/>	<input type="radio"/>	<input type="radio"/>
↗04.11	11th Step Speed Frequency	0 ~ 4000RPM (0.00~400.0Hz)	0.00	<input type="radio"/>	<input type="radio"/>	<input type="radio"/>
↗04.12	12th Step Speed Frequency	0 ~ 4000RPM (0.00~400.0Hz)	0.00	<input type="radio"/>	<input type="radio"/>	<input type="radio"/>
↗04.13	13th Step Speed Frequency	0 ~ 4000RPM (0.00~400.0Hz)	0.00	<input type="radio"/>	<input type="radio"/>	<input type="radio"/>
↗04.14	14th Step Speed Frequency	0 ~ 4000RPM (0.00~400.0Hz)	0.00	<input type="radio"/>	<input type="radio"/>	<input type="radio"/>
↗04.15	15th Step Speed Frequency	0 ~ 4000RPM (0.00~400.0Hz)	0.00	<input type="radio"/>	<input type="radio"/>	<input type="radio"/>

Group 05: IM Parameters

✎: The parameter can be set during operation.

Parameter	Explanation	Settings	Factory Setting	VF	VFPG	FOCPM
05.18	Accumulative Motor Operation Time (min.)	00~1439	0	<input type="radio"/>	<input type="radio"/>	<input type="radio"/>
05.19	Accumulative Motor Operation Time (day)	00~65535	0	<input type="radio"/>	<input type="radio"/>	<input type="radio"/>
05.21	Accumulative Drive Power-on Time (min.)	00~1439	0	<input type="radio"/>	<input type="radio"/>	<input type="radio"/>
05.22	Accumulative Drive Power-on Time (day)	00~65535	0	<input type="radio"/>	<input type="radio"/>	<input type="radio"/>

Group 6: Protection Parameters

↗: The parameter can be set during operation.

Parameter	Explanation	Settings	Factory Setting	VF	VFPG	FOCPM
↗06.00	Low Voltage Level	160.0~220.0Vdc 320.0~440.0Vdc	180.0 360.0	<input type="radio"/>	<input type="radio"/>	<input type="radio"/>
↗06.01	Phase-loss Protection	0: Warn and keep operation 1: Warn and ramp to stop 2: Warn and coast to stop	2	<input type="radio"/>	<input type="radio"/>	<input type="radio"/>
↗06.02	Over-current Stall Prevention during Acceleration	00: disable 00~250%	00	<input type="radio"/>	<input type="radio"/>	
↗06.03	Over-current Stall Prevention during Operation	00: disable 00~250%	00	<input type="radio"/>	<input type="radio"/>	
↗06.04	Accel./Decel. Time Selection of Stall Prevention at constant speed	0: by current accel/decel time 1: by the 1st accel/decel time 2: by the 2nd accel/decel time 3: by the 3rd accel/decel time 4: by the 4th accel/decel time 5: by auto accel/decel time	0	<input type="radio"/>	<input type="radio"/>	
↗06.05	Over-torque Detection Selection (OT1)	0: disable 1: over-torque detection during constant speed operation, continue to operate after detection 2: over-torque detection during constant speed operation, stop operation after detection 3: over-torque detection during operation, continue to operate after detection 4: over-torque detection during operation, stop operation after detection	0	<input type="radio"/>	<input type="radio"/>	<input type="radio"/>
↗06.06	Over-torque Detection Level (OT1)	10~250%	150	<input type="radio"/>	<input type="radio"/>	<input type="radio"/>
↗06.07	Over-torque	0.0~60.0 sec	0.1	<input type="radio"/>	<input type="radio"/>	<input type="radio"/>

Parameter	Explanation	Settings	Factory Setting	VF	VFPF	FOCPM
	Detection Time (OT1)					
↗06.08	Over-torque Detection Selection (OT2)	0: disable 1: over-torque detection during constant speed operation, continue to operate after detection 2: over-torque detection during constant speed operation, stop operation after detection 3: over-torque detection during operation, continue to operate after detection 4: over-torque detection during operation, stop operation after detection	0	<input type="radio"/>	<input type="radio"/>	<input type="radio"/>
↗06.09	Over-torque Detection Level (OT2)	10~250%	150	<input type="radio"/>	<input type="radio"/>	<input type="radio"/>
↗06.10	Over-torque Detection Time (OT2)	0.0~60.0 sec	0.1	<input type="radio"/>	<input type="radio"/>	<input type="radio"/>
↗06.11	Current Limit	0~250%	200	<input type="radio"/>	<input type="radio"/>	<input type="radio"/>
06.12	Electronic Thermal Relay Selection	0: Inverter motor 1: Standard motor 2: Disable	2	<input type="radio"/>	<input type="radio"/>	<input type="radio"/>
↗06.13	Electronic Thermal Characteristic	30.0~600.0 sec	60.0	<input type="radio"/>	<input type="radio"/>	<input type="radio"/>
↗06.14	Heat Sink Over-heat (OH) Warning	0.0~110.0°C	85.0	<input type="radio"/>	<input type="radio"/>	<input type="radio"/>
↗06.15	Stall Prevention Limit Level	0 ~ 100% (refers to Pr. 06-02, 06-03)	50	<input type="radio"/>	<input type="radio"/>	<input type="radio"/>
06.16	Present Fault Record	0: No fault	0	<input type="radio"/>	<input type="radio"/>	<input type="radio"/>
06.17	Second Most	1: Over-current during acceleration	0	<input type="radio"/>	<input type="radio"/>	<input type="radio"/>

Parameter	Explanation	Settings	Factory Setting	VF	VFPG	FOCPM
	Recent Fault Record	(ocA)				
06.18	Third Most Recent Fault Record	2: Over-current during deceleration (ocd)	0	<input type="radio"/>	<input type="radio"/>	<input type="radio"/>
06.19	Fourth Most Recent Fault Record	3: Over-current during constant speed (ocn)	0	<input type="radio"/>	<input type="radio"/>	<input type="radio"/>
06.20	Fifth Most Recent Fault Record	4: Ground fault (GFF)	0	<input type="radio"/>	<input type="radio"/>	<input type="radio"/>
06.21	Sixth Most Recent Fault Record	5 : Reserved 6: Over-current at stop (ocS) 7: Over-voltage during acceleration (ovA) 8: Over-voltage during deceleration (ovd) 9: Over-voltage during constant speed (ovn) 10: Over-voltage at stop (ovS) 11: Low-voltage during acceleration (LvA) 12: Low-voltage during deceleration (Lvd) 13: Low-voltage during constant speed (Lvn) 14: Low-voltage at stop (LvS) 15: Phase loss protection (PHL) 16: IGBT heat sink over-heat (oH1) 17 : Reserved 18 : 18: TH1 open loop error (tH1o) 19~20 : Reserved 21: over-load (oL) (150% 1Min) 22: Motor over-load (EoL1) 23~25 : Reserved 26: over-torque 1 (ot1) 27: over-torque 1 (ot2) 28: Reserved	0	<input type="radio"/>	<input type="radio"/>	<input type="radio"/>

Parameter	Explanation	Settings	Factory Setting	VF	VFPG	FOCPM
		29: Reserved 30: Memory write-in error (cF1) 31: Memory read-out error (cF2) 32: Isum current detection error (cd0) 33: U-phase current detection error (cd1) 34: V-phase current detection error (cd2) 35: W-phase current detection error (cd3) 36 : current detection error (Hd0) 37 : current detection error (Hd1) 38 : Over-voltage detection error (Hd2) 39: Ground current detection error (Hd3) 40: Auto tuning error (AuE) 41 : Reserved 42: PG feedback error (PGF1) 43: PG feedback loss (PGF2) 44: PG feedback stall (PGF3) 45: PG slip error (PGF4) 46~47 : Reserved 48: Analog current input error (ACE) 49: External fault input (EF) 50: Emergency stop (EF1) 51 : B.B. (Base Block) 52~53 : Reserved 54: Communication error (cE1) 55: Communication error (cE2) 56: Communication error (cE3) 57: Communication error (cE4) 58: Communication Time-out (cE10) 59: PU time-out (cP10)				

Group 07 Protection Parameters ⚡: The parameter can be set during operation.

Parameter	Explanation	Settings	Factory Setting	VF	VFPG	FOCPM
07.00	Reserved					
07.01	Reserved					
⚡07.02	DC Brake Current Level	0~100%	0	<input type="radio"/>	<input type="radio"/>	
⚡07.03	DC Brake Time during Start-up	0.0~60.0 sec	0.0	<input type="radio"/>	<input type="radio"/>	<input type="radio"/>
⚡07.04	DC Brake Time during Stopping	0.0~60.0 sec	0.0	<input type="radio"/>	<input type="radio"/>	<input type="radio"/>
⚡07.05	DC Brake Starting Frequency	0~4000rpm (0.00~400.0Hz)	0.00	<input type="radio"/>	<input type="radio"/>	
⚡07.06	DC Brake Proportional Gain	1~500	50	<input type="radio"/>	<input type="radio"/>	
07.07 ~ 07.10	Reserved					
⚡07.11	Fan Control	0: Fan always ON 1: 1 minute after brushless DC motor drive stops, fan will be OFF 2: Brushless DC motor drive runs and fan ON, brushless DC motor drive stops and fan OFF 3: Fan ON to run when preliminary heat sink temperature attained 4: Fan OFF	1	<input type="radio"/>	<input type="radio"/>	<input type="radio"/>
⚡07.12	Reserved					
⚡07.13	Reserved					
⚡07.14	Maximum Torque Command	0 ~ 300%	100			<input type="radio"/>
07.15 ~ 07.18	Reserved					

Parameter	Explanation	Settings	Factory Setting	VF	VFPG	FOCPM
↗07.19	Source of Torque Offset	0: Disable 1: Analog input (Pr.03-00) 2: Torque offset setting (Pr.07-20) 3: Control by external terminal (Pr.07-21 to 07-23)	0			<input type="radio"/>
↗07.20	Torque Offset Setting	0.0~100.0%	0.0			<input type="radio"/>
↗07.21	High Torque Offset	0.0~100.0%	30.0			<input type="radio"/>
↗07.22	Mid Torque Offset	0.0~100.0%	20.0			<input type="radio"/>
↗07.23	Low Torque Offset	0.0~100.0%	10.0			<input type="radio"/>
↗07.24	Forward Motor Torque Limit	0 ~ 300%	200			<input type="radio"/>
↗07.25	Forward Regenerative Torque Limit	0 ~ 300%	200			<input type="radio"/>
↗07.26	Reverse Motor Torque Limit	0 ~ 300%	200			<input type="radio"/>
↗07.27	Reverse Regenerative Torque Limit	0 ~ 300%	200			<input type="radio"/>
↗07.28	Emergency Stop (EF) & Forced Stop Selection	0: Coast to stop 1: By deceleration Time 1 2: By deceleration Time 2 3: By deceleration Time 3 4: By deceleration Time 4 5: By Pr.01-31	0	<input type="radio"/>	<input type="radio"/>	<input type="radio"/>
↗07.29	Time Required for Decreasing Torque at Stop	0.000~1.000 sec	0.000			<input type="radio"/>

Group 08 PM Parameters

↗: The parameter can be set during operation.

Parameter	Explanation	Settings	Factory Setting	VF	VFPG	FOCPM
08.00	Motor Auto Tuning	0: No function 1: Only for the unloaded motor, auto measure the angle between magnetic pole and PG origin (Pr. 08.09) 2: For PM parameters 3: Auto measure the angle between magnetic pole and PG origin (Pr.08-09)	0			<input type="radio"/>
08.01	Full-load Current of Motor	40~120%) *00.01 Amps	###			<input type="radio"/>
08.02	Rated power of Motor	0.00~655.35kW	###			<input type="radio"/>
08.03	Rated speed of Motor (rpm)	0~65535	200			<input type="radio"/>
08.04	Number of Motor Poles	2~96	10			<input type="radio"/>
08.05	Rs of Motor	0.000~65.535Ω	#			<input type="radio"/>
08.06	Reserved					
08.07	Lq of Motor	0.0~6553.5mH	#			<input type="radio"/>
08.08	Back Electromotive Force	0.0~6553.5Vrms	#			<input type="radio"/>
08.09	Angle between Magnetic Pole and PG Origin	0.0~360.0°	360.0			<input type="radio"/>
08.10	Magnetic Pole Re-orientation	0: Disable 1: Enable	0			<input type="radio"/>

Group 09 Communication Parameters ⚡: The parameter can be set during operation.

Parameter	Explanation	Settings	Factory Setting	VF	VFPG	FOCPM
⚡09.00	Communication Address	1~254	1	<input type="radio"/>	<input type="radio"/>	<input type="radio"/>
⚡09.01	Transmission Speed (Keypad)	4.8~38.4Kbps	9.6	<input type="radio"/>	<input type="radio"/>	<input type="radio"/>
⚡09.02	Transmission Fault Treatment (Keypad)	0: Warn and keep operation 1: Warn and ramp to stop 2: Reserved 3: No action and no display	3	<input type="radio"/>	<input type="radio"/>	<input type="radio"/>
⚡09.03	Time-out Detection (Keypad)	0.0 ~ 100.0 sec	0.0	<input type="radio"/>	<input type="radio"/>	<input type="radio"/>
⚡09.04	Communication Protocol (Keypad)	0: 7N1 (ASCII) 1: 7N2 (ASCII) 2: 7E1 (ASCII) 3: 7O1 (ASCII) 4: 7E2 (ASCII) 5: 7O2 (ASCII) 6: 8N1 (ASCII) 7: 8N2 (ASCII) 8: 8E1 (ASCII) 9: 8O1 (ASCII) 10: 8E2 (ASCII) 11: 8O2 (ASCII) 12: 8N1 (RTU) 13: 8N2 (RTU) 14: 8E1 (RTU) 15: 8O1 (RTU) 16: 8E2 (RTU) 17: 8O2 (RTU)	1	<input type="radio"/>	<input type="radio"/>	<input type="radio"/>
⚡09.05	Response Delay Time	0.0~200.0ms	2.0	<input type="radio"/>	<input type="radio"/>	<input type="radio"/>

Group 10: Speed Feedback Control Parameters

✎: The parameter can be set during operation.

Parameter	Explanation	Settings	Factory Setting	VF	VFPG	FOCPM
10.00	Encoder Type	0 : No function 1 : ABZ 2 : ABZ+UVW 3 : AB+PWM	3		<input type="radio"/>	<input type="radio"/>
10.01	Encoder Pulse	1~25000	256		<input type="radio"/>	<input type="radio"/>
10.02	Encoder Input Type Setting	0 : Disable 0: Disable 1: Phase A leads in a forward run command and phase B leads in a reverse run command 2: Phase B leads in a forward run command and phase A leads in a reverse run command 3 : Phase A is a pulse input and phase B is a direction input. (L=reverse direction, H=forward direction)	1		<input type="radio"/>	<input type="radio"/>
✎10.03	Encoder Feedback Fault Treatment (PGF1, PGF2)	0: Warn and keep operation 1: Warn and decelerate to stop 2: Warn and stop operation	2		<input type="radio"/>	
✎10.04	Detection Time for Encoder Feedback Fault	0.0~10.0 sec	3.0		<input type="radio"/>	<input type="radio"/>
✎10.05	Encoder Stall Level (PGF3)	0~120% (0 : disable)	115		<input type="radio"/>	<input type="radio"/>
✎10.06	Encoder Stall Detection Time	0.0 ~ 2.0 sec	0.1		<input type="radio"/>	<input type="radio"/>
✎10.07	Encoder Slip Range (PGF4)	0~50% (0 : disable)	50		<input type="radio"/>	<input type="radio"/>
✎10.08	Encoder Slip Detection Time	0.0 ~ 10.0 sec	0.5		<input type="radio"/>	<input type="radio"/>

Parameter	Explanation	Settings	Factory Setting	VF	VFPG	FOCPM
↗10.09	Encoder Stall and Slip Error Treatment	0: Warn and keep operation 1: Warn and decelerate to stop 2: Warn and stop operation	2		<input type="radio"/>	
10.10	Mode Selection for UVW Input	0: Z signal is at the falling edge of U-phase 1: Z signal is at the rising edge of U-phase	0		<input type="radio"/>	<input type="radio"/>
↗10.11	ASR (Auto Speed Regulation) Control (P) of Zero Speed	0.0~500.0%	100.0	<input type="radio"/>	<input type="radio"/>	<input type="radio"/>
↗10.12	ASR (Auto Speed Regulation) Control (I) of Zero Speed	0.000~10.000 sec	0.200	<input type="radio"/>	<input type="radio"/>	<input type="radio"/>
↗10.13	ASR (Auto Speed Regulation) Control (P) 1	0.0~500.0%	100.0	<input type="radio"/>	<input type="radio"/>	<input type="radio"/>
↗10.14	ASR (Auto Speed Regulation) Control (I) 1	0.000~10.000 sec	0.200	<input type="radio"/>	<input type="radio"/>	<input type="radio"/>
↗10.15	ASR (Auto Speed Regulation) Control (P) 2	0.0~500.0%	100.0	<input type="radio"/>	<input type="radio"/>	<input type="radio"/>
↗10.16	ASR (Auto Speed Regulation) Control (I) 2	0.000~10.000 sec	0.200	<input type="radio"/>	<input type="radio"/>	<input type="radio"/>
↗10.17	ASR 1/ASR2 Switch Frequency	0~4000RPM (0.00~400.0Hz)	7.00	<input type="radio"/>	<input type="radio"/>	<input type="radio"/>
↗10.18	ASR Primary Low Pass Filter Gain	0.000~0.350 sec	0.008	<input type="radio"/>	<input type="radio"/>	<input type="radio"/>
↗10.19	Zero Speed Gain (P)	0~655.00%	80.00			<input type="radio"/>
↗10.20	Zero Speed/ASR1	0~4000RPM (0.00~400.0Hz)	5.00		<input type="radio"/>	<input type="radio"/>

Chapter 4 ParametersAT /Troubleshooting} | BLD-E1 Series

Parameter	Explanation	Settings	Factory Setting	VF	VFPG	FOCPM
	Width Adjustment					
↗10.21	ASR1/ASR2 Width Adjustment	0~4000RPM (0.00~400.0Hz)	5.00		○	○
↗10.22	Operation Time of Zero Speed	0.000~65.535 sec	0.250			○
↗10.23	Filter Time of Zero Speed	0.000~65.535 sec	0.004			○

Group 11: Advanced Parameters

↗: The parameter can be set during operation.

Parameter	Explanation	Settings	Factory Setting	VF	VFPG	FOCPM
11.00	System Control	bit 7=1 : Enable position control bit 15=0 : when power is applied , it will re-detect the magnetic pole position	0	<input type="radio"/>	<input type="radio"/>	<input type="radio"/>
11.01 ~ 11.05	Reserved					
↗11.06	Zero-speed Bandwidth	0~40Hz	10			<input type="radio"/>
↗11.07	Low-speed Bandwidth	0~40Hz	10			<input type="radio"/>
↗11.08	High-speed Bandwidth	0~40Hz	10			<input type="radio"/>
11.09 ~ 11.15	Reserved					
11.16	Memory Address	0X0000~0XFFFF	0	<input type="radio"/>	<input type="radio"/>	<input type="radio"/>

Group 12: User-defined Parameters

(User-defined Parameters: from group 00 to 11)

✎: The parameter can be set during operation.

Parameter	Explanation	Settings	Factory Setting	VF	VFPG	FOCPM
✎12.00	Present Fault Record	0616	Read-only	<input type="radio"/>	<input type="radio"/>	<input type="radio"/>
✎12.01	Present Fault Time of Motor Operation (min.)	0632	Read-only	<input type="radio"/>	<input type="radio"/>	<input type="radio"/>
✎12.02	Present Fault Time of Motor Operation (day)	0633	Read-only	<input type="radio"/>	<input type="radio"/>	<input type="radio"/>
✎12.03	Frequency Command at Present Fault	2132	Read-only	<input type="radio"/>	<input type="radio"/>	<input type="radio"/>
✎12.04	Output Frequency at Preset Fault	2133	Read-only	<input type="radio"/>	<input type="radio"/>	<input type="radio"/>
✎12.05	Output Current at Present Fault	2134	Read-only	<input type="radio"/>	<input type="radio"/>	<input type="radio"/>
✎12.06	Motor Frequency at Present Fault	2135	Read-only	<input type="radio"/>	<input type="radio"/>	<input type="radio"/>
✎12.07	Output Voltage at Present Fault	2136	Read-only	<input type="radio"/>	<input type="radio"/>	<input type="radio"/>
✎12.08	DC-Bus Voltage at Present Fault	2137	Read-only	<input type="radio"/>	<input type="radio"/>	<input type="radio"/>
✎12.09	Output Power at Present Fault	2138	Read-only	<input type="radio"/>	<input type="radio"/>	<input type="radio"/>
✎12.10	Output Torque at Present Fault	2139	Read-only	<input type="radio"/>	<input type="radio"/>	<input type="radio"/>
✎12.11	IGBT Temperature of Power Module at Present Fault	2140	Read-only	<input type="radio"/>	<input type="radio"/>	<input type="radio"/>
✎12.12	Multi-function Terminal Input Status at Present Fault	2141	Read-only	<input type="radio"/>	<input type="radio"/>	<input type="radio"/>

Parameter	Explanation	Settings	Factory Setting	VF	VFPG	FOCPM
↗12.13	Multi-function Terminal Output Status at Present Fault	2142	Read-only	<input type="radio"/>	<input type="radio"/>	<input type="radio"/>
↗12.14	Drive Status at Present Fault	2143	Read-only	<input type="radio"/>	<input type="radio"/>	<input type="radio"/>
↗12.15	Second Most Recent Fault Record	0617	Read-only	<input type="radio"/>	<input type="radio"/>	<input type="radio"/>
↗12.16	Second Most Recent Fault Time of Motor Operation (min.)	0634	Read-only	<input type="radio"/>	<input type="radio"/>	<input type="radio"/>
↗12.17	Second Most Recent Fault Time of Motor Operation (day)	0635	Read-only	<input type="radio"/>	<input type="radio"/>	<input type="radio"/>
↗12.18	Third Most Recent Fault Record	0618	Read-only	<input type="radio"/>	<input type="radio"/>	<input type="radio"/>
↗12.19	Third Most Recent Fault Time of Motor Operation (min.)	0636	Read-only	<input type="radio"/>	<input type="radio"/>	<input type="radio"/>
↗12.20	Third Most Recent Fault Time of Motor Operation (day)	0637	Read-only	<input type="radio"/>	<input type="radio"/>	<input type="radio"/>

Parameter	Explanation	Settings	Factory Setting	VF	VFPG	FOCPM
↗ 12.21	Fourth Most Recent Fault Record	0619	Read-only	<input type="radio"/>	<input type="radio"/>	<input type="radio"/>
↗ 12.22	Fourth Most Recent Fault Time of Motor Operation (min.)	0638	Read-only	<input type="radio"/>	<input type="radio"/>	<input type="radio"/>
↗ 12.23	Fourth Most Recent Fault Time of Motor Operation (day)	0639	Read-only	<input type="radio"/>	<input type="radio"/>	<input type="radio"/>
↗ 12.24	Fifth Most Recent Fault Record	0620	Read-only	<input type="radio"/>	<input type="radio"/>	<input type="radio"/>
↗ 12.25	Fifth Most Recent Fault Time of Motor Operation (min.)	0640	Read-only	<input type="radio"/>	<input type="radio"/>	<input type="radio"/>
↗ 12.26	Fifth Most Recent Fault Time of Motor Operation (day)	0641	Read-only	<input type="radio"/>	<input type="radio"/>	<input type="radio"/>
↗ 12.27	Sixth Most Recent Fault Record	0621	Read-only	<input type="radio"/>	<input type="radio"/>	<input type="radio"/>
↗ 12.28	Sixth Most Recent Fault Time of Motor	0642	Read-only	<input type="radio"/>	<input type="radio"/>	<input type="radio"/>

Parameter	Explanation	Settings	Factory Setting	VF	VFPG	FOCPM
	Operation (min.)					
↗ 12.29	Sixth Most Recent Fault Time of Motor Operation (day)	0643	Read-only	<input type="radio"/>	<input type="radio"/>	<input type="radio"/>
↗ 12.30	No Factory Setting			<input type="radio"/>	<input type="radio"/>	<input type="radio"/>
↗ 12.31	No Factory Setting			<input type="radio"/>	<input type="radio"/>	<input type="radio"/>

Group 13: View User-defined Parameters

↗: The parameter can be set during operation.

Parameter	Explanation	Settings	Factory Setting	VF	VFPG	FOCPM
13.00 ~ 13.31	View User-defined Parameters	Pr. 00-00~11-16		○	○	○

4.2 Description of Parameter Settings

Group 00 User Parameters

⚡: This parameter can be set during operation.

00-00 Identity Code of the Brushless DC Motor Drive

Control mode	VF	VFPG	FOCPM	Factory setting: Read Only
Settings	Read Only			

00-01 Rated Current Display of the Brushless DC Motor Drive

Control mode	VF	VFPG	FCPM	Factory setting: Read Only
Settings	Read Only			

📖 Pr. 00-00 determines the drive capacity that is set by the factory. It displays the identity code of the brushless DC motor drive. The capacity, rated current, rated voltage and the max. carrier frequency relate to the identity code. Users can use the following table to check how the rated current, rated voltage and max. carrier frequency of the brushless DC drive correspond to the identity code.



📖 Pr.00-01 displays the rated current of the brushless DC motor drive. By reading this parameter the user can check if it is correct for the brushless DC motor drive.



	115V Series			460V Series				
kW	0.2	0.4	0.75	0.4	0.75	1.5	2.2	3.7
HP	0.25	0.5	1.0	0.5	1.0	2.0	3.0	5.0
Pr.00-00	0	2	4	3	5	7	9	11
Rated Output Current (A)	1.6	2.5	4.2	1.5	2.5	4.2	5.5	8.2
Max. Carrier Frequency	15Hz							



	230V Series (1-phase)					230V Series (3-phase)					
kW	0.2	0.4	0.75	1.5	2.2	0.2	0.4	0.75	1.5	2.2	3.7
HP	0.25	0.5	1.0	2.0	3.0	0.25	0.5	1.0	2.0	3.0	5.0
Pr.00-00	0	2	4	6	8	0	2	4	6	8	10
Rated Output Current (A)	4.9	6.5	9.7	15.7	24	1.9	2.7	4.9	9.0	15	17.0
Max. Carrier Frequency	15kHz										

00-02		Parameter Reset			Factory setting: 0
Control mode	VF	VFPG	FOCPM		
Settings	0	No Function			
	10	All parameters are reset to factory settings			
	When it is set to 10, all parameters will be reset to factory settings.				
					

00-03		Start-up Display Selection			Factory setting: 0
Control mode	VF	VFPG	FOCPM		
Settings	0	Display the frequency command value. (F)			
	1	Display the actual output frequency (H)			
	2	DC BUS voltage (V)			
	3	Display the output current (A)			
	4	Output voltage (E)			
	5	Multifunction display, see Pr.00-04			

 This parameter determines the start-up display page after power is applied to the drive. User defined options are displayed according to Pr.00-04.

00-04		Content of Multi-Function Display			Factory setting: 0
Control mode	VF	VFPG	FOCPM		
Settings	0	Display the output current in A supplied to the motor			
	1	Reserved			
	2	Display actual output frequency (H)			
	3	Display the actual DC BUS voltage in VDC of the brushless DC motor drive (U)			
	4	Display the output voltage in VAC of terminals U, V, W to the motor (E)			
	5	Display the power factor angle in ° of terminals U, V, W to the motor (n.)			
	6	Display the output power in kW of terminals U, V and W to the motor (kW)			
	7	Display the actual motor speed in rpm (enabled when using with PG card).			
	8	Display the estimated value of torque in % as it relates to current.			
	9	Display PG position			

00-04  Content of Multi-Function Display

- 10 Display the electrical angle of drive output
- 11 Display the signal of VR analog input terminal in %.
Range 0~10V corresponds to 0~100%.
- 12 Display the signal of ACI analog input terminal in %.
Range 4~20mA/0~10V corresponds to 0~100%.
- 13 Display the signal of AVI analog input terminal in %.
Range -10V~10V corresponds to 0~100%.
- 14 Reserved
- 15 Display the temperature of IGBT in °C.
- 16 Display digital input status ON/OFF
- 17 Display digital output status ON/OFF
- 18 Display multi-step speed
- 19 The corresponding CPU pin status of digital input
- 20 The corresponding CPU pin status of digital output
- 21
| Reserved
- 23
- 24 Output AC voltage when malfunction
- 25 Output DC voltage when malfunction
- 26 Motor frequency when malfunction
- 27 Output current when malfunction
- 28 Output frequency when malfunction
- 29 Frequency command when malfunction
- 30 Output power when malfunction
- 31 Output torque when malfunction
- 32 Input terminal status when malfunction
- 33 Output terminal status when malfunction
- 34 Drive status when malfunction



It is used to display the content when LED U is ON. It is helpful for getting the brushless DC motor drive's status by this parameter.

Terminal	MI8	MI7	MI6	MI5	MI4	MI3	MI2	MI1	REV	FWD
Status	0	0	1	0	0	0	0	1	1	0

0: OFF, 1: ON

MI3: Pr.02-01 is set to 1 (multi-step speed command 1)

MI6: Pr.02-04 is set to 8 (the 1st, 2nd acceleration/deceleration time selection)

If REV, MI2, MI3 and MI6 are ON, the value is 0000 0000 0010 0110B in binary and 0026H in HEX. At the meanwhile, if Pr.00-04 is set to “16” or “19”, it will display “0026” with LED U is ON on the keypad KPV-L-CC01. The setting 16 is the status of digital input and the setting 19 is the corresponding CPU pin status of digital input. User can set to 16 to monitor digital input status and then set to 19 to check if the wire is normal.

Terminal	MO2	MO1
Status	0	1

RA: Pr.02-13 is set to 9 (Drive ready).

After applying the power to the brushless DC motor drive, if there is no other abnormal status, the contact will be ON. At the meanwhile, if Pr.00-04 is set to 17 or 20, it will display 0001 with LED U is ON on the keypad. The setting 17 is the status of digital output and the setting 20 is the corresponding CPU pin status of digital output. User can set 17 to monitor the digital output status and then set to 20 to check if the wire if normal.

00-05 ↗ Reserved

00-06 Software Version

Control mode	VF	VFP	FOCPM	Factory setting: #.##
	Settings	Read Only		

00-07 Selection of motor stop method

Control mode	VF	VFP	FOCPM	Factory setting: 0
	Settings	0: ramp to stop		
		1: coast to stop		

 As the drive receives “stop” command, the stop method will be according to this parameter setting.

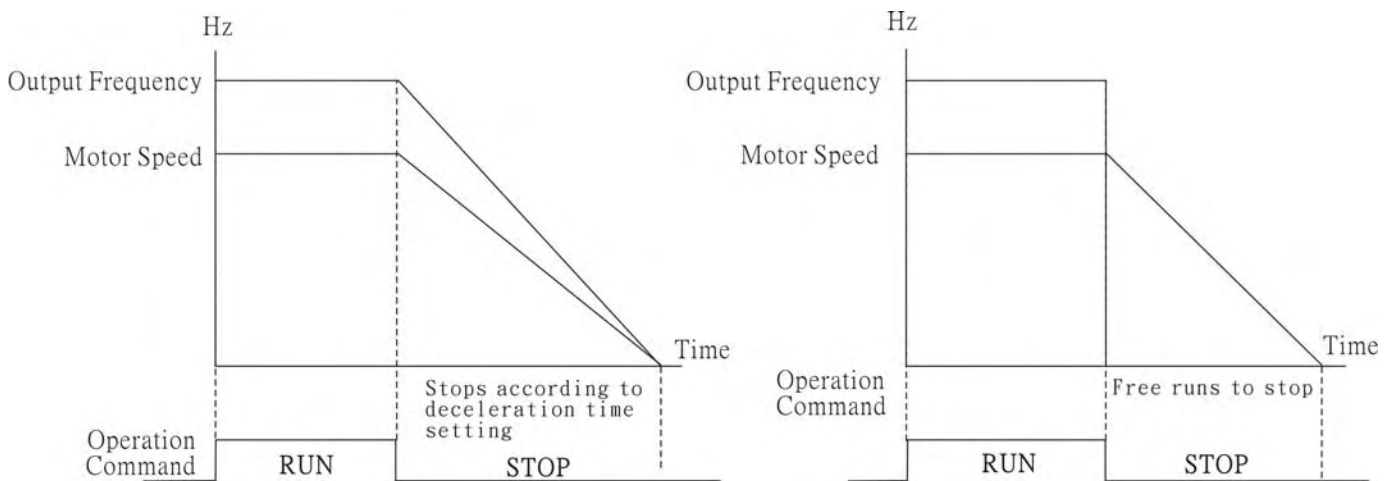

Ramp to Stop and Coast to Stop



Ramp to stop: the brushless DC decelerates the motor to Minimum Output Frequency



Pr.01-09 and stops according to the deceleration time set in Pr.01-07.



Coast to stop: the brushless DC drive stops output instantly upon command, and motor free run until it comes to a complete stop.



If the machinery is turned off, the motor must also be stopped to avoid waste of power and for safety concern. It is suggested to set the brake ramp to stop with ramping duration matches machinery characteristics.



As the machinery is turned off, if it is allowed for motor to spin freely or the inertia load is large, it is suggested to set the motor to coast to stop.



00-08 Setting of Motor Running Direction

Control mode	VF	VFPG	FOCPM	Factory setting: 0
Settings			0 : reverse running allowed 1 : reverse running not allowed 2 : forward running not allowed	



This parameter prevents the machine damage which caused by fwd/rev motor run error.



00-09 Control Method

Control mode	VF	VFPG	FOCPM	Factory Setting: 0
Settings			0 V/f control 1 V/f + Encoder (VFPG) 8 FOC PM control (FOCPM)	

- This parameter determines the control method of the brushless DC motor drive:
 Setting 0: user can design V/f ratio by requirement and control multiple motors simultaneously.
 Setting 1: User can use PG card with Encoder to do close-loop speed control.
 Setting 8: To increase torque and control speed precisely. (1:1000). This setting is only for using with permanent magnet motor and others are for induction motor.

00-10		Speed Unit			Factory Setting: 0
Control mode	VF	VFPG	FOCPM		
	Settings	0	Hz		
		3	RPM		

- When parameter 00.10=3, the setting of parameter 01.00, .09~01.11, 01.23, 01.29, 02.25~02.28, 04.00~04.15, 07.05, 10.17, 10.20 and 10.21 will adjust according to the different running speed (RPM).

00-11		Reserved		
-------	--	----------	--	--

00-12		Carrier Frequency			Factory setting: 8
Control mode	VF	VFPG	FOCPM		
	Settings	2~15KHz			

- This parameter determinates the PWM carrier frequency of the brushless DC motor drive.

Carrier Frequency	Acoustic Noise	Electromagnetic Noise or Leakage Current	Heat Dissipation	Current Wave
2kHz	Significant	Minimal	Minimal	
8kHz	↑	↑	↑	
15kHz	Minimal	Significant	Significant	

- From the table, we see that the PWM carrier frequency has a significant influence on the electromagnetic noise, brushless DC motor drive heat dissipation, and motor acoustic noise.
- If the ambient noise is greater than motor acoustic noise, lower PWM carrier frequency would allow better heat dissipation.
- Though a higher PWM carrier frequency will provide quiet operation, it is necessary to check if the wiring system and anti-interference function support this action.
- If carrier frequency is higher than default setting and must be lowered but meanwhile overload has reaches the adjusting limit, then the carrier frequency (Fc) will self-adjust in response to the ambient temperature and current level.
- For example, a 460V series under ambient temperature 40 °C, carrier frequency 15kHz and rated output current 55% ; if rated output current is now 87%, in responding to the ambient

temperature, carrier frequency will be lowered to 10kHz, moreover, overload condition will be adjust, e.g. $F_c = 15\text{kHz}$, rated output current = $50\% * 55\% = 82.5\%$ and continues for 1 minute, the carrier frequency (F_c) will be reduced to the default setting.



Overload Adjusting Graph

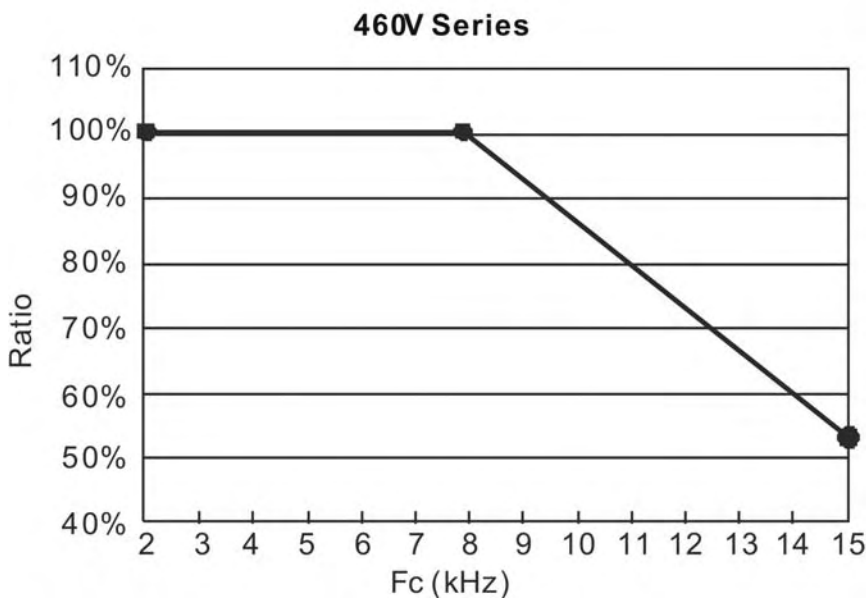
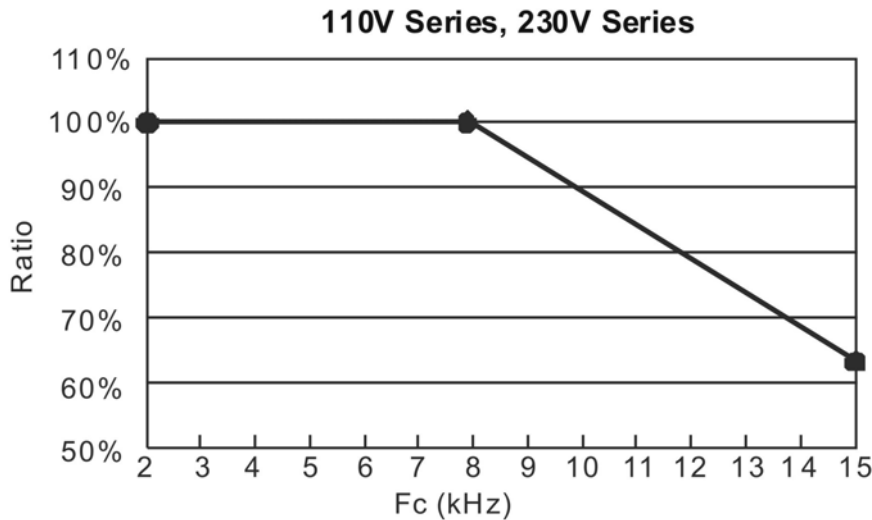

The control of maximum running speed differ upon PWM setting, therefore, carrier frequency setting must be 27 times greater than the actual outputted frequency to attain best speed control response.



For example, if Pr.00-12 setting is 2K, in order to attain best rotation speed control response, the max. output frequency must be less than 74.07Hz. When number of motor poles is 5, the rotation speed is controlled to around 888rpm; in this case, it is recommend to set carrier frequency to 2K and speed command to 900rpm. When carrier frequency (Pr. 00-12) setting is 6K or lower, please refer to the following chart for value of carrier frequency and rotation speed:



2K (Pr. 00-12 = 2)	900rpm
3K (Pr. 00-12 = 3)	1350rpm
4K (Pr. 00-12 = 4)	1800rpm
5K (Pr. 00-12 = 5)	2250rpm
6K (Pr. 00-12 = 6)	2700rpm
Greater than 7K (Pr. 00-12 >7K)	3000rpm

00-13 *✓* Auto Voltage Regulation (AVR) Function

Control mode	VF	VFPG	FOCPM	Factory setting: 0
Settings		0	Enable AVR	
		1	Disable AVR	
		2	Disable AVR when deceleration	

 It is used to select the AVR mode. AVR is used to regulate the output voltage to the motor. For example, if V/f curve is set to AC200V/50Hz and the input voltage is from 200 to 264VAC, the output voltage won't excess AC200V/50Hz. If the input voltage is from 180 to 200V, the output voltage to the motor and the input voltage will be in direct proportion.

 When setting Pr.00-13 to 1 during ramp to stop and used with auto accel./decel. function, the the deceleration will be smoother and faster.



00-14 *✓* Source of the Master Frequency Command

Control mode	VF	VFPG	FOCPM	Factory setting: 2
Settings		0	Digital keypad input	
		1	RS-485 serial communication input	
		2	External analog input (Pr. 03-00~03-02)	
		3	Digital terminals input (Pr.04-00~04-15)	

 This parameter determines the drive's master frequency source.

00-15 *✓* Source of the Operation Command

Control mode	VF	VFPG	FOCPM	Factory setting: 0
Settings		0	Digital keypad control	
		1	External terminal control	
		2	RS-485 serial communication or digital keypad (KPV L-CC01) control	



BLE-E1 series is shipped without digital keypad and users can use external terminals or RS-485 to control the operation command.



When the LED PU is light, the operation command can be controlled by the optional digital keypad (KPC-CE01). Refer to appendix B for details.



Group 01 Basic Parameters

✎ This parameter can be set during operation.

01-00	Maximum Output Frequency			Factory setting: 3000(250)
Control mode	VF	VFPG	FOCPM	
Settings	120~4000rpm (10~400z)			

 This parameter determines the brushless DC motor drive's Maximum Output Frequency. All the brushless DC motor drive frequency command sources (analog frequency inputs 0 to +10V and 4 to 20mA) are scaled to correspond to the output frequency range.

01-01	1st Output Frequency Setting			Factory setting: 60.00
Control mode	VF	VFPG	FOCPM	
Settings	0.00~400.00Hz			

 It is for the base frequency and motor rated frequency.

 This value should be set according to the rated frequency of the motor as indicated on the motor nameplate. If the motor is 60Hz, the setting should be 60Hz. If the motor is 50Hz, it should be set to 50Hz.



01-02	1st Output Voltage Setting			Factory Setting: 220.0
Control mode	VF	VFPG	FOCPM	
Settings	230V series	0.1 to 255.0V		Factory Setting: 220.0
	460V series	0.1 to 510.0V		Factory Setting: 440.0

 It is for the base frequency and motor rated frequency.

 This value should be set according to the rated voltage of the motor as indicated on the motor nameplate. If the motor is 220V, the setting should be 220.0. If the motor is 200V, it should be set to 200.0.

 There are many motor types in the market and the power system for each country is also difference. The economic and convenience method to solve this problem is to install the brushless DC motor drive. There is no problem to use with the different voltage and frequency and also can amplify the original characteristic and life of the motor.

01-03	2nd Output Frequency Setting			
Control mode	VF	VFPG		Factory setting: 0.50
	Settings	0.00~400.00Hz		
01-04	↗ 2nd Output Voltage Setting			
Control mode	VF	VFPG		
	Settings	230V series	0.1 to 255.0V	Factory Setting: 5.0
		460V series	0.1 to 510.0V	Factory Setting: 10.0
01-05	3rd Output Frequency Setting			
Control mode	VF	VFPG		Factory setting: 0.50
	Settings	0.00~400.00Hz		
01-06	↗ 3rd Output Voltage Setting			
Control mode	VF	VFPG		
	Settings	230V series	0.1 to 255.0V	Factory Setting: 5.0
		460V series	0.1 to 510.0V	Factory Setting: 10.0
01-07	4th Output Frequency Setting			
Control mode	VF	VFPG		
	Settings	0.00~400.00Hz		Factory Setting: 0
01-08	↗ 4th Output Voltage Setting			
Control mode	VF	VFPG		
	Settings	230V series	0.1 to 255.0V	Factory Setting: 0.0
		460V series	0.1 to 510.0V	Factory Setting: 0.0

-  V/f curve setting is usually set by the motor's allowable loading characteristics. Pay special attention to the motor's heat dissipation, dynamic balance, and bearing lubricity, if the loading characteristics exceed the loading limit of the motor.
-  For the V/f curve setting, it should be $Pr.01-01 \geq Pr.01-03 \geq Pr.01-05 \geq Pr.01-07$. There is no limit for the voltage setting, but a high voltage at the low frequency may cause motor damage, overheat, stall prevention or over-current protection. Therefore, please use the low voltage at the low frequency to prevent motor damage.
-  V/F curve would only function as $Pr. 00-09 = 0$ or 1 (under V/F control mode) and $Pr. 00-10 = 0$.

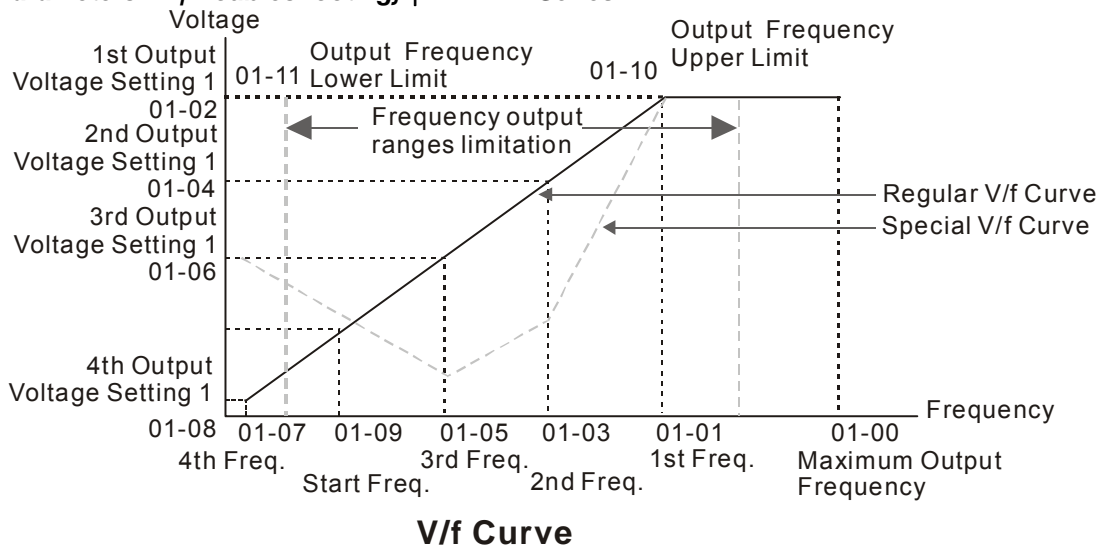

01-09	Start Frequency			
Control mode	VF	VFPG		Factory setting: 6
Settings	0.00~400.00Hz			

To distinguish which frequency should be start frequency, it needs to compare the value of min. output frequency and start frequency. The larger value will be start frequency.
 When min. output frequency > start frequency When start frequency > min. output frequency

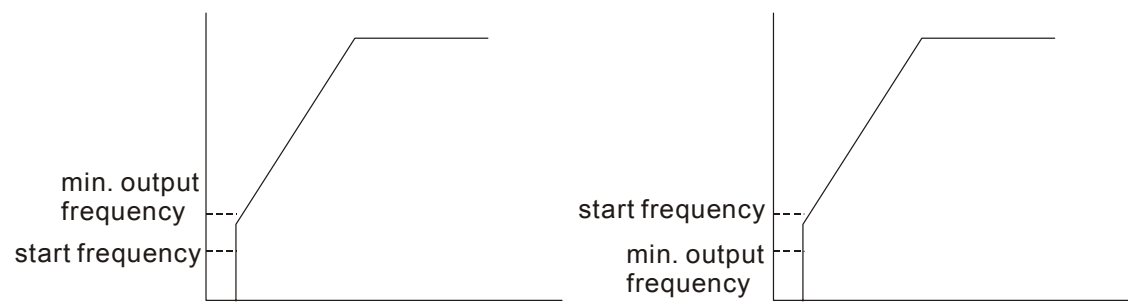

01-10	Output Frequency Upper Limit			
Control mode	VF	VFPG	FOCPM	Factory setting: 3000
Settings	0.00~4800rpm			

01-11	Output Frequency Lower Limit			
Control mode	VF	VFPG	FOCPM	Factory setting: 0.00
Settings	0.00~4800rpm			

The upper/lower output frequency setting is used to limit the actual output frequency. If the frequency setting is lower than the start-up frequency, it will run with zero speed. If the frequency setting is higher than the upper limit, it will runs with the upper limit frequency. If output frequency lower limit > output frequency upper limit, this function is invalid.



01-12	✓ Accel. Time 1	Factory setting: 3.00
01-14	✓ Accel. Time 2	Factory setting: 3.00
01-16	✓ Accel. Time 3	Factory setting: 3.00
01-18	✓ Accel. Time 4	Factory setting: 3.00
Control mode	VF VFG FOCPM	
	Settings	0.00~600.00 sec

01-13	✓ Decel. Time 1	Factory setting: 2.00
01-15	✓ Decel. Time 2	Factory setting: 2.00
01-17	✓ Decel. Time 3	Factory setting: 2.00
01-19	✓ Decel. Time 4	Factory setting: 2.00
Control mode	VF VFG FOCPM	
	Settings	0.00~600.00 sec



The Acceleration Time is used to determine the time required for the brushless DC motor drive to ramp from 0Hz to Maximum Output Frequency (Pr.01-00).



The Deceleration Time is used to determine the time required for the brushless DC motor drive to decelerate from the Maximum Output Frequency (Pr.01-00) down to 0Hz.



The Acceleration/Deceleration Time 1, 2, 3, 4 are selected according to the Multi-function Input Terminals settings. The factory settings are acceleration time 1 and deceleration time 1.



The larger against torque and inertia torque of the load and the accel./decel. time setting is less than the necessary value, it will enable torque limit and stall prevention function. When it happens, actual accel./decel. time will be longer than the action above.

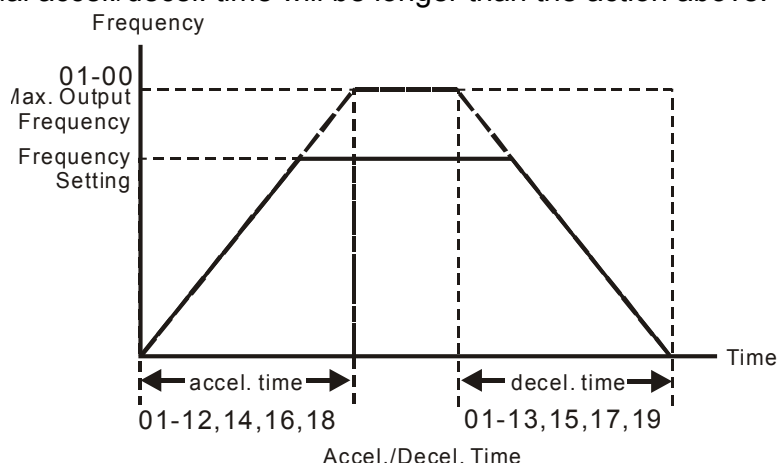

01-20	✓ Reserved
0-21	✓ Reserved
0-22	✓ Reserved

01-23	↗ Switch Frequency between 1st/4th Accel/decel	Factory setting: 0
Control mode	VF VFG FOCPM	

Settings 0.00~400.00Hz

- 📖 This parameter selects the frequency point for transition from acceleration/deceleration time 1 to acceleration/deceleration time 4.
- 📖 The transition from acceleration/deceleration time 1 to acceleration/deceleration time 4, may also be enabled by the external terminals. The external terminal has priority over Pr. 01-23.

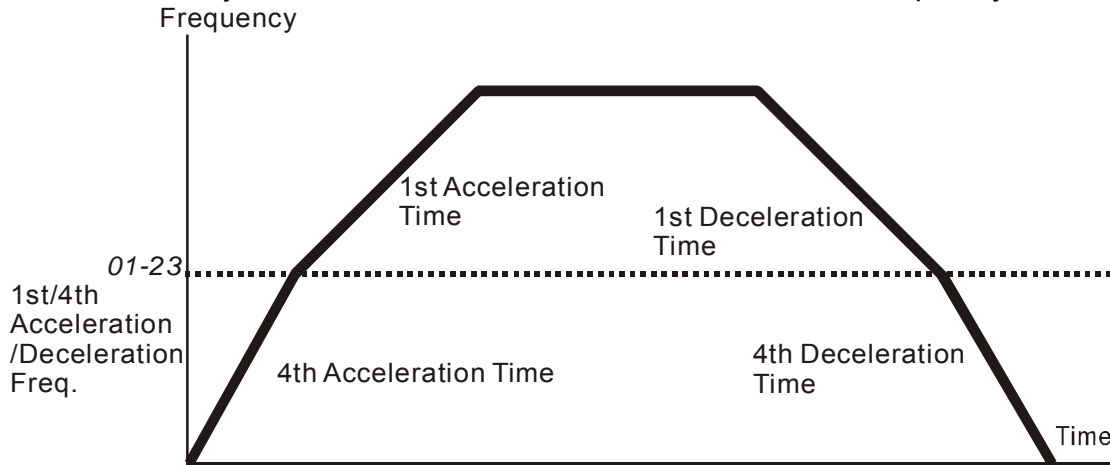

1st/4th Acceleration/Deceleration Switching

01-24	↗ S-curve for Acceleration Departure Time S1	Factory setting: 1.00
01-25	↗ S-curve for Acceleration Arrival Time S2	Factory setting: 1.00
01-26	↗ S-curve for Deceleration Departure Time S3	Factory setting: 1.00
01-27	↗ S-curve for Deceleration Arrival Time S4	Factory setting: 1.00
01-30	↗ S-curve for Deceleration Arrival Time S5	Factory setting: 1.00
Control mode	VF VFG FOCPM	Factory setting: 1.00

Settings 0.00~25.00 sec

01-29	↗ Switch Frequency for S Changes to S5	Factory setting: 0.00
Control mode	VF VFG FOCPM	

Settings 0.00~4800rpm

- 📖 It is used to give the smoothest transition between speed changes. The accel./decel. curve can adjust the S-curve of the accel./decel. When it is enabled, the drive will have different accel./decel. curve by the accel./decel. time.
- 📖 The Actual Accel. Time = selected accel. Time + (Pr.01-24 + Pr.01-25)/2
The Actual Decel. Time = selected decel. Time + (Pr.01-26 + Pr.01-27)/2
- 📖 Parameter 01-29 is used to set the switch frequency between S4 and S5 for smooth stop.

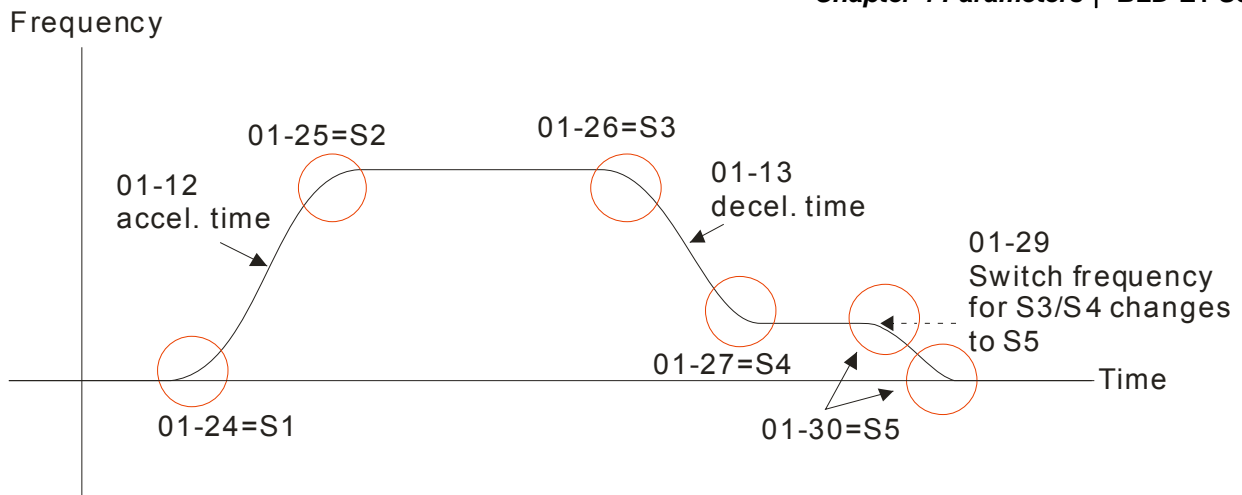

01-28 Mode Selection when Frequency < Fmin

Control mode	VF	VFPG	SVC	Factory setting: 0
Settings		0	Output Waiting	
		1	Zero-speed operation	
		2	Fmin (4th output frequency setting)	

- When the Brushless DC motor drive is at 0rpm, it will operate by this parameter.
- When it is set to 1 or 2, voltage will be output by Fmin corresponding output voltage(Pr.01-08).

01-31 ⚡ Deceleration Time when Operating without RUN Command

Control mode	VF	VFPG	FOCPM	Factory setting: 2.00
Settings		0.00~600.00	Sec	

- The brushless DC motor drive will stop by the setting of this parameter when canceling RUN command. Refer to the figure in Pr.01-29 for details.

Group 2 Digital Input/Output Parameters ⚡ This parameter can be set during operation.

02-00	2-wire/3-wire Operation Control			Factory setting: 0
Control mode	VF	VFP	FOCPM	
Settings		0	FWD/STOP, REV/STOP	
		1	FWD/STOP, REV/STOP (Line Start Lockout)	
		2	RUN/STOP, REV/FWD	
		3	RUN/STOP, REV/FWD (Line Start Lockout)	
		4	3-wire	
		5	3-wire (Line Start Lockout)	

Three of the six methods include a “Line Start Lockout” feature. When line start lockout is enabled, the drive will not run once applying the power. The Line Start Lockout feature doesn’t guarantee the motor will never start under this condition. It is possible the motor may be set in motion by a malfunctioning switch.

This parameter is used to control operation from external terminals. There are three different control modes.



02-00	Control Circuits of the External Terminal	
0, 1 2-wire operation control (1) FWD/STOP REV/STOP		MI1 FWD:(<input type="checkbox"/> OPEN":STOP) ("CLOSE":FWD) MI2 REV:(<input type="checkbox"/> OPEN":STOP) ("CLOSE":REV) COM
2, 3 2-wire operation control (2) RUN/STOP REV/FWD		MI1 FWD:(<input type="checkbox"/> OPEN":STOP) ("CLOSE":RUN) MI2 REV:(<input type="checkbox"/> OPEN":FWD) ("CLOSE":REV) COM
4, 5 3-wire operation control		MI 1 FWD "CLOSE":RUN MI3 <input type="checkbox"/> OPEN":STOP MI2 REV/FWD "OPEN": FWD CLOSE": REV COM

02-01 Multi-Function Input Command 3 (MI3)

Factory Setting: 1

02-02 Multi-Function Input Command 4 (MI4)

Factory Setting: 2

02-03 Multi-Function Input Command 5 (MI5)



Factory Setting: 3

02-04 Multi-Function Input Command 6 (MI6)

Factory Setting: 4

Settings	VF	VFPG	FOCPM
0 : no function	<input type="radio"/>	<input type="radio"/>	<input type="radio"/>
1 : Multi-step command 1	<input type="radio"/>	<input type="radio"/>	<input type="radio"/>
2 : Multi-step command 2	<input type="radio"/>	<input type="radio"/>	<input type="radio"/>
3 : Multi-step command 3	<input type="radio"/>	<input type="radio"/>	<input type="radio"/>
4 : Multi-step command 4	<input type="radio"/>	<input type="radio"/>	<input type="radio"/>
5 : Reset	<input type="radio"/>	<input type="radio"/>	<input type="radio"/>
6 : Reserved			
7 : acceleration/deceleration speed inhibit	<input type="radio"/>	<input type="radio"/>	<input type="radio"/>
8 : the 1st, 2nd acceleration/deceleration time selection	<input type="radio"/>	<input type="radio"/>	<input type="radio"/>
9 : the 3rd, 4th acceleration/deceleration time selection	<input type="radio"/>	<input type="radio"/>	<input type="radio"/>
10: EF input (Pr.07-28)	<input type="radio"/>	<input type="radio"/>	<input type="radio"/>
11: Reserved			
12: Stop output	<input type="radio"/>	<input type="radio"/>	<input type="radio"/>
13~14: Reserved			
15 : Running speed command from VR	<input type="radio"/>	<input type="radio"/>	<input type="radio"/>
16 : Running speed command from ACI	<input type="radio"/>	<input type="radio"/>	<input type="radio"/>
17 : Running speed command from AVI	<input type="radio"/>	<input type="radio"/>	<input type="radio"/>
18 : Emergency Stop (Pr.07-28)	<input type="radio"/>	<input type="radio"/>	<input type="radio"/>
19~26 : Reserved			
27 : ASR1/ASR2 Selection	<input type="radio"/>	<input type="radio"/>	<input type="radio"/>
28 : Emergency stop (EF1) (Motor coasts to stop)	<input type="radio"/>	<input type="radio"/>	<input type="radio"/>
29~30 : Reserved			
31: High torque bias (by Pr.07-21)	<input type="radio"/>	<input type="radio"/>	<input type="radio"/>
32: Middle torque bias (by Pr.07-22)	<input type="radio"/>	<input type="radio"/>	<input type="radio"/>

Settings	VF	VFPG	FOCPM
33: Low torque bias (by Pr.07-23)	<input type="radio"/>	<input type="radio"/>	<input type="radio"/>
34-37: Reserved			
38: Disable EEPROM write function	<input type="radio"/>	<input type="radio"/>	<input type="radio"/>
39 : Reserved			
40 : Enable drive to function	<input type="radio"/>	<input type="radio"/>	<input type="radio"/>

-  This parameter selects the functions for each multi-function terminal.
-  If Pr.02-00 is set to 3-wire operation control. Terminal MI1 is for STOP terminal. Therefore, MI1 is not allowed for any other operation.



Settings	Functions	Descriptions
0	No Function	
1	Multi-step speed command 1	15 step speeds could be conducted through the digital statuses of the 4 terminals, and 17 in total if the master speed and JOG are included. (Refer to Pr. 04-00~04-15)
2	Multi-step speed command 2	
3	Multi-step speed command 3	
4	Multi-step speed command 4	When using communication to control the multi-step speed, setting 1 to 4 will be invalid.
5	Reset	After the error of the drive is eliminated, use this terminal to reset the drive.
6	Reserved	
7	Acceleration/deceleration Speed Inhibit	When this function is enabled, acceleration and deceleration is stopped and the brushless DC motor drive starts to accel./decel. from the inhibit point.

Settings	Functions	Descriptions															
8	The 1 st , 2 nd acceleration or deceleration time selection	<p>The acceleration/deceleration time of the drive could be selected from this function or the digital statuses of the terminals; there are 4 acceleration/deceleration speeds in total for selection.</p> <table border="1"> <thead> <tr> <th>Bit 0</th> <th>Bit 1</th> <th>Descriptions</th> </tr> </thead> <tbody> <tr> <td>0</td> <td>0</td> <td>First acceleration/deceleration time When output frequency is less than Pr.01-23 (Switch Frequency between 1st/4th accel/decel), it will output 4th accel/decel time.</td> </tr> <tr> <td>0</td> <td>1</td> <td>2nd accel./decel. time</td> </tr> <tr> <td>1</td> <td>0</td> <td>3rd accel./decel. time</td> </tr> <tr> <td>1</td> <td>1</td> <td>4th accel./decel. time</td> </tr> </tbody> </table>	Bit 0	Bit 1	Descriptions	0	0	First acceleration/deceleration time When output frequency is less than Pr.01-23 (Switch Frequency between 1st/4th accel/decel), it will output 4th accel/decel time.	0	1	2nd accel./decel. time	1	0	3rd accel./decel. time	1	1	4th accel./decel. time
Bit 0	Bit 1	Descriptions															
0	0	First acceleration/deceleration time When output frequency is less than Pr.01-23 (Switch Frequency between 1st/4th accel/decel), it will output 4th accel/decel time.															
0	1	2nd accel./decel. time															
1	0	3rd accel./decel. time															
1	1	4th accel./decel. time															
9	The 3 rd , 4 th acceleration or deceleration time selection	<p>If the drive receives STOP command, it will decelerate to stop by Pr.01-31.</p>															
10	EF Input	External fault input terminal and decelerates by Pr.07-28. (EF fault will be recorded)															
11	Reserved																
12	Stop output	When this function is enabled, the drive output will stop immediately and the motor is free run. When this function is disabled, the drive will accelerate to the frequency setting.															
13-14	Reserved																
15	Operation speed command form VR	<p>When the source of operation speed command is set to VR, ACI and AVI at the same time and two or above terminals are ON, the priority is VR>ACI>AVI.</p> <p>When this function is enabled, the source of the frequency will force to be VR.</p>															
16	Operation speed command form ACI	When this function is enabled, the source of the frequency will force to be ACI.															
17	Operation speed command form AVI	When this function is enabled, the source of the frequency will force to be AVI.															
18	Emergency Stop	When this function is enabled, the drive will ramp to stop by Pr.07-28 setting.															
19-26	Reserved																

Settings	Functions	Descriptions																																				
27	ASR1/ASR2 selection	ON: speed will be adjusted by ASR 2 setting. OFF: speed will be adjusted by ASR 1 setting.																																				
28	Emergency stop (EF1) (Motor coasts to stop)	When it is ON, the drive will execute emergency stop with fault code 50 (EF1)																																				
29-30	Reserved																																					
31	High torque bias	When Pr.07-19 is set to 3: 31: The high torque bias is according to the Pr.07-21 setting. 32: The middle torque bias is according to the Pr.07-22 setting. 33: The low torque bias is according to the Pr.07-23 setting.																																				
32	Middle torque bias																																					
33	Low torque bias																																					
		<table border="1"> <thead> <tr> <th>31</th> <th>32</th> <th>33</th> <th>Torque Bias</th> </tr> </thead> <tbody> <tr> <td>OFF</td> <td>OFF</td> <td>OFF</td> <td>No</td> </tr> <tr> <td>OFF</td> <td>OFF</td> <td>ON</td> <td>07-23</td> </tr> <tr> <td>OFF</td> <td>ON</td> <td>OFF</td> <td>07-22</td> </tr> <tr> <td>OFF</td> <td>ON</td> <td>ON</td> <td>07-23+07-22</td> </tr> <tr> <td>ON</td> <td>OFF</td> <td>OFF</td> <td>07-21</td> </tr> <tr> <td>ON</td> <td>OFF</td> <td>ON</td> <td>07-21+07-23</td> </tr> <tr> <td>ON</td> <td>ON</td> <td>OFF</td> <td>07-21+07-22</td> </tr> <tr> <td>ON</td> <td>ON</td> <td>ON</td> <td>07-21+07-22+07-23</td> </tr> </tbody> </table>	31	32	33	Torque Bias	OFF	OFF	OFF	No	OFF	OFF	ON	07-23	OFF	ON	OFF	07-22	OFF	ON	ON	07-23+07-22	ON	OFF	OFF	07-21	ON	OFF	ON	07-21+07-23	ON	ON	OFF	07-21+07-22	ON	ON	ON	07-21+07-22+07-23
31	32	33	Torque Bias																																			
OFF	OFF	OFF	No																																			
OFF	OFF	ON	07-23																																			
OFF	ON	OFF	07-22																																			
OFF	ON	ON	07-23+07-22																																			
ON	OFF	OFF	07-21																																			
ON	OFF	ON	07-21+07-23																																			
ON	ON	OFF	07-21+07-22																																			
ON	ON	ON	07-21+07-22+07-23																																			
34-37	Reserved																																					
38	Disable write EEPROM function	When this function is enabled, you can't write into EEPROM.																																				
39	Reserved																																					
40	Enable drive function	When this function is enabled, the drive function can be executed. This function can be used with multi-function output (setting Pr.02-11~Pr.02-14 to 15) and (Pr.02-31 and Pr.02-32).																																				

02-05	Reserved
02-06	Reserved
02-07	Reserved
02-08	Reserved

02-09 ⚡ Digital Input Response Time

Control mode	VF	VFP	FOCPM	Factory setting: 0.005
Settings	0.001~ 30.000 sec			

 This parameter is used for digital input terminal signal delay and confirmation. The delay time is confirmation time to prevent some uncertain interferences that would result in error (except for the counter input) in the input of the digital terminals (FWD, REV and MI1~6). Under this condition, confirmation for this parameter could be improved effectively, but the response time will be somewhat delayed.

02-10 ⚡ Digital Input Operation Direction

Control mode	VF	VFP	FOCPM	Factory setting: 0
Settings	0 ~ 65535			

 This parameter is used to set the input signal level and it won't be affected by the SINK/SOURCE status.

 Bit0 is for FWD terminal, bit1 is for REV terminal and bit2 to bit9 is for MI1 to MI8.

 User can change terminal status by communicating.

For example, MI1 is set to 1 (multi-step speed command 1), MI2 is set to 2 (multi-step speed command 2). Then the forward + 2nd step speed command=1001(binary)=9 (Decimal). Only need to set Pr.02-10=9 by communication and it can forward with 2nd step speed. It doesn't need to wire any multi-function terminal.



bit5	bit4	bit3	bit2	bit1	bit0
MI6	MI5	MI4	MI3	MI2	MI1

02-11 ⚡ Reserved**02-12** ⚡ Reserved**02-13** ⚡ Multi-function Output 3 (MO1)**02-14** ⚡ Multi-function Output 4 (MO2)

Factory Setting: 0

Settings	VF	VFP	FOCPM
0 : No function	<input type="radio"/>	<input type="radio"/>	<input type="radio"/>
1: Operation indication	<input type="radio"/>	<input type="radio"/>	<input type="radio"/>
2: Operation speed attained	<input type="radio"/>	<input type="radio"/>	<input type="radio"/>

Chapter 4 ParametersAT /Troubleshooting} | BLD-E1 Series

3 : Desired frequency attained 1 (Pr. 02-25, 02-26)	<input type="radio"/>	<input type="radio"/>	<input type="radio"/>
4 : Desired frequency attained 2 (Pr. 02-27, 02-28)	<input type="radio"/>	<input type="radio"/>	<input type="radio"/>
5: Zero speed (frequency command)	<input type="radio"/>	<input type="radio"/>	<input type="radio"/>
6: Zero speed with stop (frequency command)	<input type="radio"/>	<input type="radio"/>	<input type="radio"/>
7: Over torque (OT1)	<input type="radio"/>	<input type="radio"/>	<input type="radio"/>
8: Over torque (OT2)	<input type="radio"/>	<input type="radio"/>	<input type="radio"/>
9: Drive ready	<input type="radio"/>	<input type="radio"/>	<input type="radio"/>
10 : Low-voltage Detection (LV)	<input type="radio"/>	<input type="radio"/>	<input type="radio"/>
11 : Malfunction indication	<input type="radio"/>	<input type="radio"/>	<input type="radio"/>
12 : Reserved			
13 : Overheat warning (Pr. 06-14)	<input type="radio"/>	<input type="radio"/>	<input type="radio"/>
14~16 : Reserved	<input type="radio"/>	<input type="radio"/>	<input type="radio"/>
17 : Malfunction indication 1	<input type="radio"/>	<input type="radio"/>	<input type="radio"/>
18~19 : Reserved			
20 : Warning output	<input type="radio"/>	<input type="radio"/>	<input type="radio"/>
21 : Ove voltage warning	<input type="radio"/>	<input type="radio"/>	<input type="radio"/>
22 : Over-current stall prevention warning	<input type="radio"/>	<input type="radio"/>	<input type="radio"/>
23 : Over-voltage stall prevention warning	<input type="radio"/>	<input type="radio"/>	<input type="radio"/>
24 : Drive operation mode(Pr. 00-21=0)	<input type="radio"/>	<input type="radio"/>	<input type="radio"/>
25: Forward running command	<input type="radio"/>	<input type="radio"/>	<input type="radio"/>
26: Reverse running command	<input type="radio"/>	<input type="radio"/>	<input type="radio"/>
27~30 : Reserved			
31 : Forward running input	<input type="radio"/>	<input type="radio"/>	<input type="radio"/>
32 : Reverse running input	<input type="radio"/>	<input type="radio"/>	<input type="radio"/>
33 : Zero-speed (Actual output frequency)	<input type="radio"/>	<input type="radio"/>	<input type="radio"/>
34 : Zero speed with Stop (actual output frequency)	<input type="radio"/>	<input type="radio"/>	<input type="radio"/>
35~39 : Reserved			
40 : Speed attained (including zero speed)	<input type="radio"/>	<input type="radio"/>	<input type="radio"/>

Settings	Functions	Descriptions
0	No Function	
1	AC Drive Operational	Active when there is an output from the drive or RUN command is ON.
2	Operation speed attained	Active when the brushless DC motor drive reaches the output frequency setting.
3	Desired Frequency Attained 1 (Pr.02-25, 02-26)	Active when the desired frequency (Pr.02-25, 02-26) is attained.
4	Desired Frequency Attained 2 (Pr.02-27, 02-28)	Active when the desired frequency (Pr.02-27, 02-28) is attained.
5	Zero Speed (frequency command)	Active when frequency command =0. (the drive should be at RUN mode)
6	Zero Speed with Stop (frequency command)	Active when frequency command =0 or stop.
7	Over Torque (OT1)	Active when detecting over-torque. Refer to Pr.06-05 (over-torque detection selection-OT1), Pr.06-06 (over-torque detection level-OT1) and Pr.06-07 (over-torque detection time-OT1). (Pr.06-05~06-07)
8	Over Torque (OT2)	Active when detecting over-torque. Refer to Pr.06-08 (over-torque detection selection-OT2), Pr.06-09 (over-torque detection level-OT2) and Pr.06-10 (over-torque detection time-OT2). (Pr.06-08~06-10)
9	Drive Ready	Active when the drive is ON and no abnormality detected.
10	User-defined Low-voltage Detection	Active when the DC Bus voltage is too low. (refer to Pr.06-00 low voltage level)
11	Malfunction Indication	Active when fault occurs (except Lv stop).
12	Reserved	
13	Overheat (Pr.06-14)	Active when IGBT or heat sink overheats to prevent OH turn off the drive. (refer to Pr.06-14)
14~16	Reserved	
17	Malfunction indication 1	Activate after 10ms when fault occurs (except Lv stop).
18~19	Reserved	
20	Warning Output	Active when the warning is detected.
21	Over-voltage Warning	Active when the over-voltage is detected.

Settings	Functions	Descriptions
22	Over-current Stall Prevention Warning	Active when the over-current stall prevention is detected.
23	Over-voltage Stall prevention Warning	Active when the over-voltage stall prevention is detected.
24	Operation Mode Indication	Active when the operation command is controlled by external terminal. (Pr.00-15=1) and PU LED on keypad KPVL-CC01 is OFF.
25	Forward Command	Active when the operation direction is forward.
26	Reverse Command	Active when the operation direction is reverse.
27~30	Reserved	
31	Forward running input	Motor forward run (FWD).
32	Reverse running input	Motor Reverse run (REV).
33	Zero Speed (actual output frequency)	Active when the actual output frequency is 0. (the drive should be at RUN mode)
34	Zero Speed with Stop (actual output frequency)	Active when the actual output frequency is 0 or Stop. (the drive should be at RUN mode)
35~39	Reserved	
40	Speed Attained (including zero speed)	Active when the output frequency reaches frequency setting.

02-15	Reserved
02-16	Reserved
02-17	Reserved
02-18	Reserved
02-19	Reserved
02-20	Reserved
02-21	Reserved
02-22	Reserved

02-23	Multi-output Direction
Control mode	VF VFPG FOCPM
	Factory setting: 0
Settings	0 ~ 65535

 This parameter is bit setting. If the bit is 1, the multi-function output terminal will be act with opposite direction. For example, if Pr.02-13 is set to 1 and forward bit is 0, Relay 1 will be ON

when the drive is running and OFF when the drive is stop; if multi-function output terminal is set to opposite direction, Relay will be OFF when the drive is running and ON when the drive is stop.



Bit 1	Bit 0
MO2	MO1

02-24 Reserved

02-25 ✓ Desired Frequency Attained 1

Control mode VF VFPG FOCPM Factory setting: 0

02-26 ✓ The Width of the Desired Frequency Attained 1

Control mode VF VFPG FOCPM Factory setting: 24

02-27 ✓ Desired Frequency Attained 2

Control mode VF VFPG FOCPM Factory setting: 0

02-28 ✓ The Width of the Desired Frequency Attained 2

Control mode VF VFPG FOCPM Factory setting: 24

Settings 0.00 ~ 4800rpm



Once output frequency reaches desired frequency and the corresponding multi-function output terminal is set to 3 or 4 (Pr.02-11~Pr.02-22), this multi-function output terminal will be ON.

Group 3 Analog Input/Output Parameters *↗*This parameter can be set during operation.

03-00	<i>↗</i> Analog Input 1 (VR)	Factory Setting: 1
03-01	<i>↗</i> Analog Input 2 (ACI)	Factory Setting: 0
03-02	<i>↗</i> Analog Input 3 (AVI)	Factory Setting: 0



Settings	VF	VFPG	FOCPM
0: No function	<input type="radio"/>	<input type="radio"/>	<input type="radio"/>
1: Frequency command (torque limit under TQR control mode)	<input type="radio"/>	<input type="radio"/>	<input type="radio"/>
2: Reserved			
3: Preload input	<input type="radio"/>	<input type="radio"/>	<input type="radio"/>
4-6: Reserved			
7: Positive torque limit			<input type="radio"/>
8: Negative torque limit			<input type="radio"/>
9: Regenerative torque limit			<input type="radio"/>
10: Positive/negative torque limit			<input type="radio"/>

When it is frequency command or TQR speed limit, the corresponding value for 0~±10V/4~20mA is 0 – max. output frequency(Pr.01-00)

When it is torque command or torque limit, the corresponding value for 0~±10V/4~20mA is 0 – max. output torque (Pr.07-14).

When it is torque compensation, the corresponding value for 0~±10V/4~20mA is 0 – rated torque.

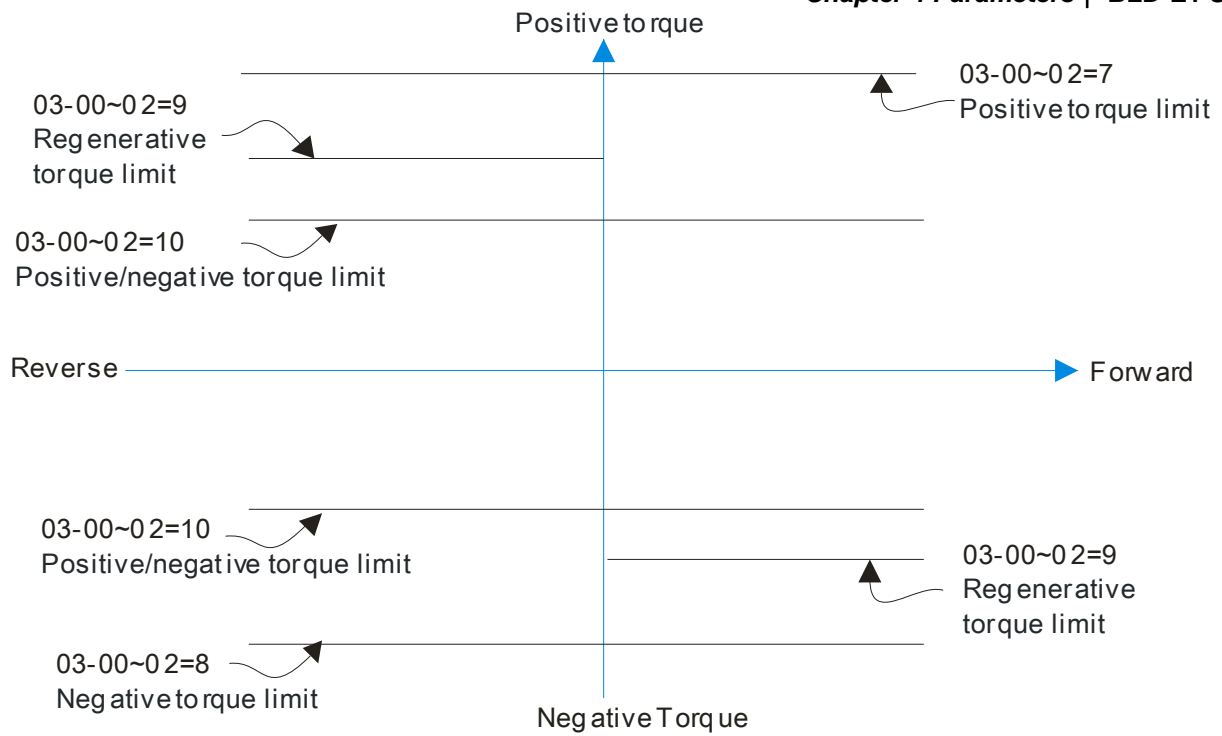

03-03 / Analog Input Bias 1 (VR)

Control mode	VF	VFGP	FOCPM	Factory setting: 0.0
Settings	-100.0~100.0%			

It is used to set the corresponding VR voltage of the external analog input 0.

03-04 / Analog Input Bias 1 (ACI)

Control mode	VF	VFGP	FOCPM	Factory setting: 0.0
Settings	-100.0~100.0%			

It is used to set the corresponding ACI voltage of the external analog input 0.

03-05 / Analog Input Bias 1 (AVI)

Control mode	VF	VFGP	FOCPM	Factory setting: 0.0
Settings	-100.0~100.0%			

It is used to set the corresponding AVI voltage of the external analog input 0.

The relation between external input voltage/current and setting frequency is equal to -10~+10V (4-20mA) corresponds to 0~3000rpm.

03-06 / Positive/negative Bias Mode (VR)

Control mode	VF	VFGP	FOCPM	Factory setting: 0
--------------	----	------	-------	--------------------

03-07	↗ Positive/negative Bias Mode (ACI) (can be set to 0 or 1 only)			Factory setting: 0
Control mode	VF	VFPG	FOCPM	

03-08	↗ Positive/negative Bias Mode (AVI)			Factory setting: 0
Control mode	VF	VFPG	FOCPM	

- | | | |
|----------|---|---|
| Settings | 0 | Zero bias |
| | 1 | Serve bias as the center, lower than bias=bias |
| | 2 | Serve bias as the center, greater than bias=bias |
| | 3 | The absolute value of the bias voltage while serving as the center (unipolar) |
| | 4 | Serve bias as the center (unipolar) |

 In a noisy environment, it is advantageous to use negative bias to provide a noise margin. It is recommended NOT to use less than 1V to set the operating frequency.

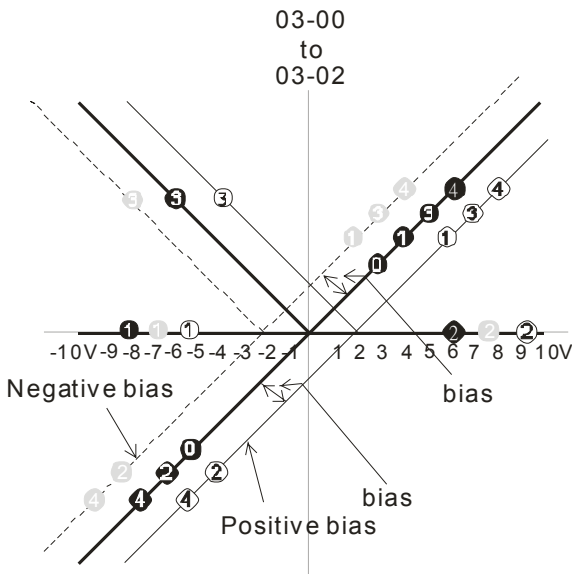

03-09~03-11 gain is positive

- 0 Zero bias
- 1 Serve bias as the center, lower than bias = bias
- 2 Serve bias as the center, greater than bias=bias
- 3 The absolute value of the bias voltage while serving as the center (unipolar)
- 4 Serve bias as the center(unipolar)

03-09	↗ Analog Input Gain 1 (VR)			Factory setting: 100.0
Control mode	VF	VFPG	FOCPM	



03-10	↗ Analog Input Gain 1 (ACI)			Factory setting: 100.0
Control mode	VF	VFPG	FOCPM	

03-11	↗ Analog Input Gain 1 (AVI)			Factory setting: 100.0
Control mode	VF	VFPG	FOCPM	

Settings 0.0~500.0%

 Parameters 03-03 to 03-11 are used when the source of frequency command is the analog voltage/current signal.

03-12		↗ Analog Input Delay Time (VR)			
Control mode	VF	VFPG	FOCPM		Factory setting: 0.05
03-13		↗ Analog Input Delay Time (ACI)			
Control mode	VF	VFPG	FOCPM		Factory setting: 0.05
03-14		↗ Analog Input Delay Time (AVI)			
Control mode	VF	VFPG	FOCPM		Factory setting: 0.05
Settings		0.00 to 2.00 sec			

-  Interferences commonly exist with analog signals, such as those entering VR, ACI and AVI. These interferences constantly affect the stability of analog control and using the Input Noise Filter will create a more stable system.
-  If time setting is large, the control will be stable, yet the response to the input will be slow. If time setting is small, the control may be unstable, yet the response to the input will fast.

03-15		↗ Loss of the ACI Signal			
Control mode	VF	VFPG	FOCPM		Factory setting: 0
Settings		0	Disable		
		1	Continue operation at the last frequency		
		2	Decelerate to stop 0Hz		
		3	Stop immediately and display E.F.		

-  This parameter determines the behavior when ACI (4-20mA) is lost. This parameter determines the behavior when ACI (4-20mA) is lost. This parameter determines the behavior when ACI (4-20mA) is lost.



Group 4 Multi-Step Speed Parameters ↗ This parameter can be set during operation.

04-00	↗ Zero Step Speed Frequency
04-01	↗ 1st Step Speed Frequency
04-02	↗ 2nd Step Speed Frequency
04-03	↗ 3rd Step Speed Frequency
04-04	↗ 4th Step Speed Frequency
04-05	↗ 5th Step Speed Frequency
04-06	↗ 6th Step Speed Frequency
04-07	↗ 7th Step Speed Frequency
04-08	↗ 8th Step Speed Frequency
04-09	↗ 9th Step Speed Frequency
04-10	↗ 10th Step Speed Frequency
04-11	↗ 11th Step Speed Frequency
04-12	↗ 12th Step Speed Frequency
04-13	↗ 13th Step Speed Frequency
04-14	↗ 14th Step Speed Frequency
04-15	↗ 15th Step Speed Frequency

Control mode	VF	VFP	FOCPM	Factory setting: 0
	Settings	0 to 8000rpm		

 The Multi-Function Input Terminals (refer to Pr.02-01 to 02-04) are used to select one of the brushless DC motor drive Multi-step speeds. The speeds (frequencies) are determined by Pr.04-00 to Pr. 04-15 as shown above.

Group 5 IM Parameters

✎ This parameter can be set during operation.

05-18	Accumulative Motor Operation Time (Min.)			
Control mode	VF	VFPG	FOCPM	Factory setting: 00
	Settings	00 to 1439		

05-19	Accumulative Motor Operation Time (Day)			
Control mode	VF	VFPG	FOCPM	Factory setting: 00
	Settings	00 to 65535		

 Pr. 05-18 and Pr.05-19 are used to record the motor operation time. They can be cleared by setting to 00 and time which is less than 60 seconds will not be recorded.

05-20	Accumulative Drive Power-on Time (Min.)			
Control mode	VF	VFPG	FOCPM	Factory setting: 00
	Settings	00 to 1439		

05-21	Accumulative Drive Power-on Time (day)			
Control mode	VF	VFPG	FOCPM	Factory setting: 00
	Settings	00 to 65535		

Group 6 Protection Parameters

⚡ This parameter can be set during operation.

06-00	⚡ Low Voltage Level		
Control mode	VF	VFP	FOCPM
Settings	230V series	160.0~220.0Vdc	
	460V series	320.0~440.0Vdc	
			Factory Setting: 180.0
			Factory Setting: 360.0

📖 It is used to set the Lv level.

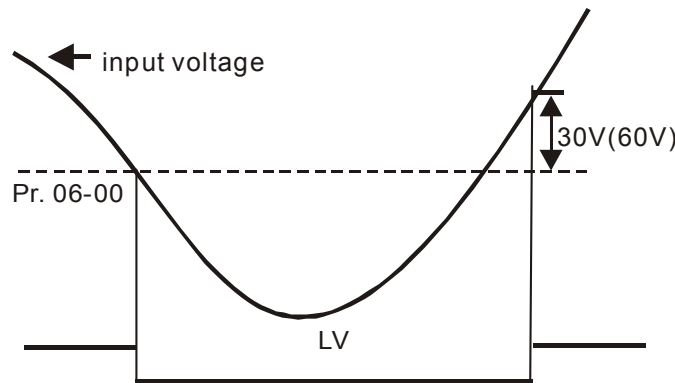

06-01	⚡ Phase-loss Protection		
Control mode	VF	VFP	FOCPM
			Factory setting: 2
Settings	0	Warn and keep operation	
	1	Warn and ramp to stop	
	2	Warn and coast to stop	

📖 It is used to set the phase-loss treatment. The phase-loss will effect drive's control characteristic and life.

06-02	⚡ Over-Current Stall Prevention during Acceleration		
Control mode	VF	VFP	
			Factory setting: 00
Settings	00: disable		
	00~250%		

📖 During acceleration, the AC drive output current may increase abruptly and exceed the value specified by Pr.06-02 due to rapid acceleration or excessive load on the motor. When this function is enabled, the AC drive will stop accelerating and keep the output frequency constant until the current drops below the maximum value.

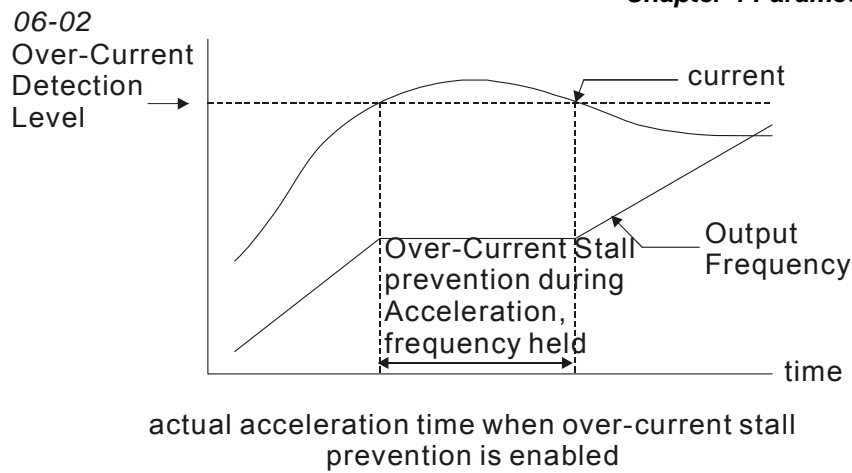

06-03 Over-current Stall Prevention during Operation

Control mode	VF	VFPG	Factory setting: 00
Settings	00: disable	00 to 250%	

If the output current exceeds the setting specified in Pr.06-03 when the drive is operating, the drive will decrease its output frequency by Pr.06-04 setting to prevent the motor stall. If the output current is lower than the setting specified in Pr.06-03, the drive will accelerate (by Pr.06-04) again to catch up with the set frequency command value.

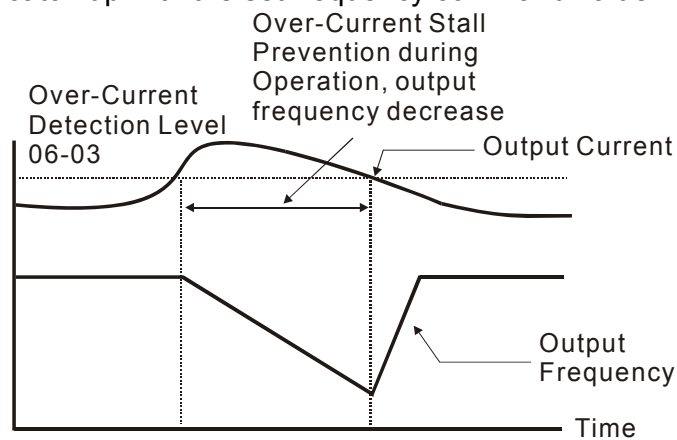

over-current stall prevention during operation

06-04 Accel./Decel. Time Selection of Stall Prevention at constant speed

Control mode	VF	VFPG	Factory setting: 0
Settings	0	by current accel/decel time	
	1	by the 1st accel/decel time	
	2	by the 2nd accel/decel time	
	3	by the 3rd accel/decel time	
	4	by the 4th accel/decel time	
	5	by auto accel/decel time	

 It is used to set the accel./decel. time selection when stall prevention occurs at constant speed.

06-05 ⚡ Over-torque Detection Selection (OT1)			
Control mode	VF	VFPG	FOCPM
			Factory setting: 0
Settings		0	Over-Torque detection disabled.
		1	Over-torque detection during constant speed operation, continue to operate after detection
		2	Over-torque detection during constant speed operation, stop operation after detection
		3	Over-torque detection during operation, continue to operate after detection
		4	Over-torque detection during operation, stop operation after detection

06-06 ⚡ Over-torque Detection Level (OT1)			
Control mode	VF	VFPG	FOCPM
			Factory setting: 150
Settings		10 to 250%	

06-07 ⚡ Over-torque Detection Time (OT1)			
Control mode	VF	VFPG	FOCPM
			Factory setting: 0.1
Settings		0.0 to 60.0 sec	

06-08 ⚡ Over-torque Detection Selection (OT2)			
Control mode	VF	VFPG	FOCPM
			Factory setting: 0
Settings		0	Over-Torque detection disabled.
		1	Over-torque detection during constant speed operation, continue to operate after detection
		2	Over-torque detection during constant speed operation, stop operation after detection
		3	Over-torque detection during operation, continue to operate after detection
		4	Over-torque detection during operation, stop operation after detection

06-09 ⚡ Over-torque Detection Level (OT2)			
Control mode	VF	VFPG	FOCPM
			Factory setting: 150
Settings		10 to 250%	

06-10	↗ Over-torque Detection Time (OT2)			Factory setting: 0.1
Control mode	VF	VFPG	FOCPM	
Settings	0.0 to 60.0 sec			

Pr.06-05 and Pr.06-08 determine the operation mode of the drive after the over-torque is detected via the following method: if the output current exceeds the over-torque detection level (Pr.06-06) and also exceeds the Pr.06-07 Over-Torque Detection Time, the fault code “OT1/OT2” is displayed. If a Multi-Functional Output Terminal is to over-torque detection, the output is on. Please refer to Pr.02-11~02-22 for details.

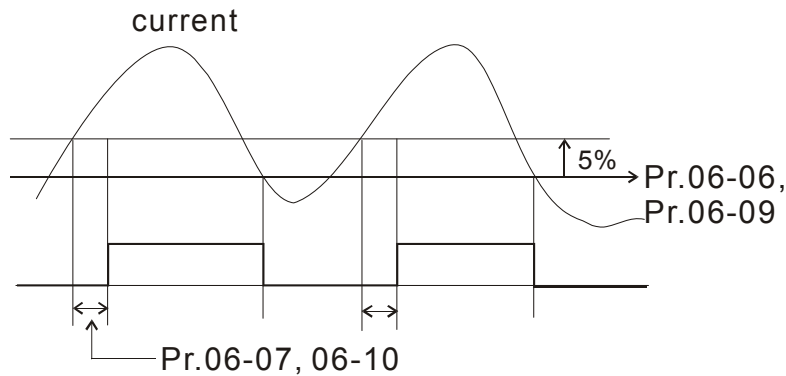

06-11	↗ Current Limit			1
Control mode	FOCPG	TQCPG	FOCPM	Factory setting: 200
Settings	0 to 250%			

This parameter is used to set the current limit.

06-12	Electronic Thermal Relay Selection			Factory setting: 2
Control mode	VF	VFPG	FOCPM	
Settings	0	Inverter motor		
	1	Standard motor		
	2	Disabled		

It is used to prevent self-cooled motor overheats under low speed. User can use electrical thermal relay to limit driver’s output power.

06-13	↗ Electronic Thermal Characteristic			Factory setting: 60.0
Control mode	VF	VFPG	FOCPM	
Settings	30.0 to 600.0 sec			

Chapter 4 ParametersAT [Troubleshooting] | BLD-E1 Series

The parameter is set by the output frequency, current and operation time of the drive for activating the I^2t electronic thermal protection function. The function will be activated for the 150% * setting current for the setting of Pr.06-13

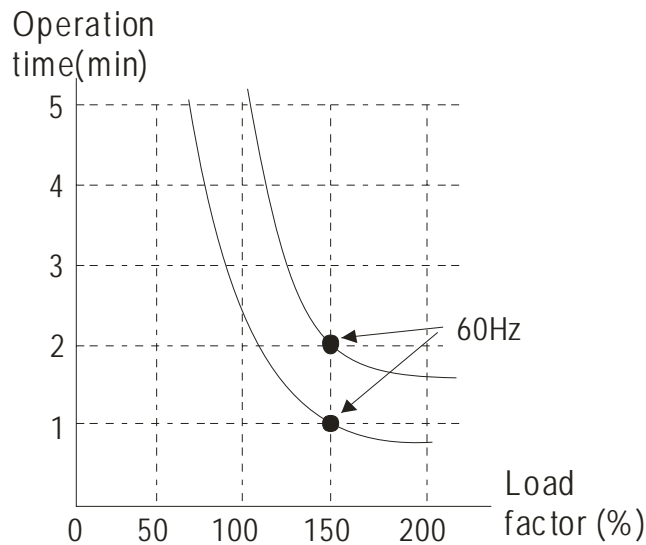

06-14	Heat Sink Over-heat (OH) Warning			
Control mode	VF	VFP	FOCPM	Factory setting: 85.0
Settings	0.0 to 110.0 °C			

06-15	Stall Prevention Limit Level			
Control mode	VF	VFP	FOCPM	Factory setting: 50
Settings	0 to 100% (refer to Pr.06-02, Pr.06-03)			

When the operating frequency is larger than Pr.01-01, Pr06-02=150%, Pr. 06-03=100% and Pr. 06-15=80%:

Stall Prevention Level during acceleration = $06-02 \times 06-15 = 150 \times 80\% = 120\%$.

Stall Prevention Level at constant speed = $06-03 \times 06-15 = 100 \times 80\% = 80\%$.

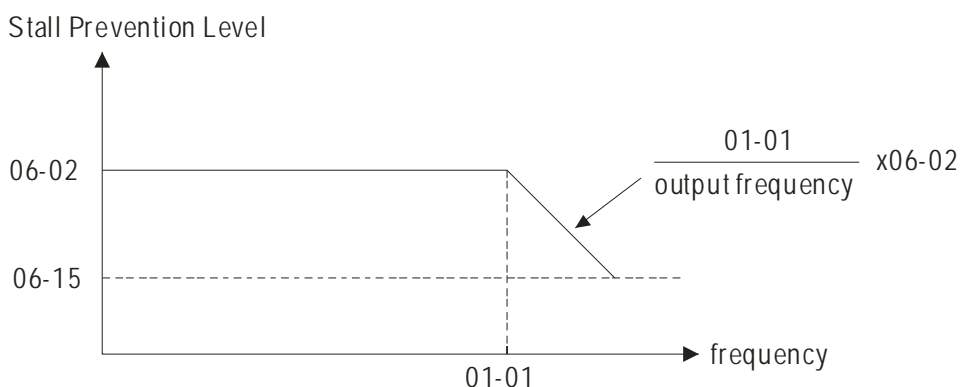

06-16	Present Fault Record
06-17	Second Most Recent Fault Record
06-18	Third Most Recent Fault Record
06-19	Fourth Recent Fault Record
06-20	Fifth Most Recent Fault Record
06-21	Sixth Most Recent Fault Record

Control mode	VF	VFPG	FOCPM	Factory setting: 0
Readings	0		No fault	
	1		Over-current during acceleration (ocA)	
	2		Over-current during deceleration (ocd)	
	3		Over-current during constant speed (ocn)	
	4		Ground fault (GFF)	
	5		Reserved	
	6		Over-current at stop (ocS)	
	7		Over-voltage during acceleration (ovA)	
	8		Over-voltage during deceleration (ovd)	
	9		Over-voltage during constant speed (ovn)	
	10		Over-voltage at stop (ovS)	
	11		Low-voltage during acceleration (LvA)	
	12		Low-voltage during deceleration (Lvd)	
	13		Low-voltage during constant speed (Lvn)	
	14		Low-voltage at stop (LvS)	
	15		Phase loss (PHL)	
	16		IGBT heat sink over-heat (oH1)	
	17		heat sink over-heat 40HP above (oH2)	
	18		TH1 open loop error (tH1o)	
	19		Reserved	
	20		Reserved	
	21		Over-load (oL) (150% 1Min)	
	22		Motor over-load (EoL1)	
	23		Reserved	
	24		Reserved	
	25		Reserved	
	26		Over-torque 1 (ot1)	
	27		Over-torque 1 (ot2)	

28	Reserved
29	Reserved
30	Memory write-in error (cF1)
31	Memory read-out error (cF2)
32	Isum current detection error (cd0)
33	U-phase current detection error (cd1)
34	V-phase current detection error (cd2)
35	W-phase current detection error (cd3)
36	Clamp current detection error (Hd0)
37	Over-current detection error (Hd1)
38	Over-voltage detection error (Hd2)
39	Ground current detection error (Hd3)
40	Auto tuning error (AuE)
41	Reserved
42	PG feedback error (PGF1)
43	PG feedback loss (PGF2)
44	PG feedback stall (PGF3)
45	PG slip error (PGF4)
46	Reserved
47	Reserved
48	Analog current input error (ACE)
49	External fault input (EF)
50	Emergency stop (EF1)
51	B.B. (Base Block)
52	Reserved
53	Reserved
54	Communication error (cE1)
55	Communication error (cE2)
56	Communication error (cE3)
57	Communication error (cE4)
58	Communication Time-out (cE10)

59 PU time-out (cP10)



It will record when the fault occurs and force stopping. For the Lv, it will record when it is operation, or it will warn without record.

Group 7 Special Parameters

↗ This parameter can be set during operation.

07-00	Reserved
07-01	Reserved

07-02	↗ DC Brake Current Level			Factory Setting: 0.0
Control mode	VF	VFPG		
	Settings	0 to 100%		

 This parameter sets the level of DC Brake Current output to the motor during start-up and stopping. When setting DC Brake Current, the Rated Current (Pr.00-01) is regarded as 100%. It is recommended to start with a low DC Brake Current Level and then increase until proper holding torque has been attained.

 When it is FOCPM mode, it can enable DC brake function by setting to any value.

07-03	↗ DC Brake Time during Start-up			Factory Setting: 0.0
Control mode	VF	VFPG	FOCPM	
	Settings	0.0 to 60.0 sec		

 This parameter determines the duration of the DC Brake current after a RUN command.

07-04	↗ DC Brake Time during Stopping			Factory Setting: 0.0
Control mode	VF	VFPG	FOCPM	
	Settings	0.0 to 60.0 sec		

 This parameter determines the duration of the DC Brake current during stopping.

07-05	↗ Start-Point for DC Brake			Factory Setting: 0
Control mode	VF	VFPG		
	Settings	0.00 to 48000rpm		

 This parameter determines the frequency when DC Brake will begin during deceleration. When the setting is less than start frequency (Pr.01-09), start-point for DC brake will begin from the min. frequency.

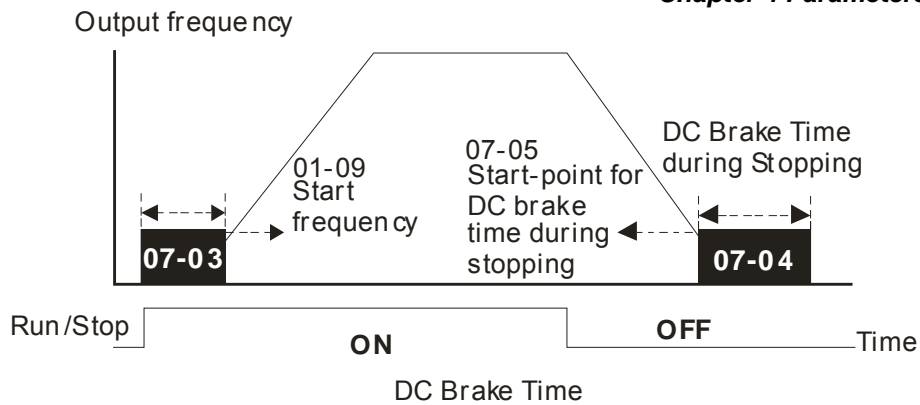

07-06	DC Brake Proportional Gain		
Control mode	VF	VFPG	Factory Setting: 50
Settings	1 to 500Hz		

It is used to set the output voltage gain when brushless DC brake.

07-07	Reserved
07-08	Reserved
07-09	Reserved
07-10	Reserved

07-11	Fan Control		
Control mode	VF	VFPG	FOCPM
Settings	0	Fan always ON	
	1	1 minute after DC brushless motor drive stops, fan will be OFF	
	2	Brushless DC motor drive runs and fan ON, brushless DC motor drive stops and fan OFF	
	3	Fan ON to run when preliminary heat sink temperature attained	
	4	Fan always OFF	

This parameter is used for the fan control.

When setting to 3, fan will start to run until temperature is less than 40°C if temperature exceeds 40°C.

07-12	Reserved
07-13	Reserved

07-14	↗ Maximum Torque Command	
Control mode	FOCPM	Factory Setting: 100
Settings	0 to 300%	

 This parameter is for the max. torque command (motor rated torque is 100%).

07-15	↗ Reserved
07-16	↗ Reserved
07-17	↗ Reserved
07-18	↗ Reserved

07-19	↗ Source of Torque Offset	
Control mode	FOCPM	Factory Setting: 0
Settings	0 Disable 1 Analog input (Pr.03-00) 2 Torque offset setting (Pr.07-20) 3 Control by external terminal (by Pr.07-21 to Pr.07-23)	

 This parameter is the source of torque offset.

 When it is set to 3, the source of torque offset will decide to Pr.07-21, Pr.07-22 and Pr.07-23 by the multi-function input terminals setting (31, 32 or 33).

02-01~02-08 is set to 31	02-01~02-08 is set to 32	02-01~02-08 is set to 33	Torque offset
OFF	OFF	OFF	None
OFF	OFF	ON	07-23
OFF	ON	OFF	07-22
OFF	ON	ON	07-23+07-22
ON	OFF	OFF	07-21
ON	OFF	ON	07-21+07-23
ON	ON	OFF	07-21+07-22
ON	ON	ON	07-21+07-22+07-23

07-20	↗ Torque Offset Setting	
Control mode	FOCPM	Factory Setting: 0.0
Settings	0.0 to 100.0%	

 This parameter is torque offset. The motor rated torque is 100%.

07-21	↗ High Torque Offset	
Control mode	FOCPM	Factory Setting: 30.0
Settings	0.0 to 100.0%	

07-22	↗ Middle Torque Offset	
Control mode	FOCPM	Factory Setting: 20.0
Settings	0.0 to 100.0%	

07-23	↗ Low Torque Offset	
Control mode	FOCPM	Factory Setting: 10.0
Settings	0.0 to 100.0%	

When it is set to 3, the source of torque offset will decide to Pr.07-21, Pr.07-22 and Pr.07-23 by the multi-function input terminals setting (19, 20 or 21). The motor rated torque is 100%.

07-24	↗ Forward Motor Torque Limit	
07-25	↗ Forward Regenerative Torque Limit	
07-26	↗ Reverse Motor Torque Limit	
07-27	↗ Reverse Regenerative Torque Limit	
Control mode	FOCPM	Factory Setting: 200
Settings	0 to 300%	

The motor rated torque is 100%. The settings for Pr.07-24 to Pr.07-27 will compare with Pr.03-00=5, 6, 7, 8. The minimum of the comparison result will be torque limit.

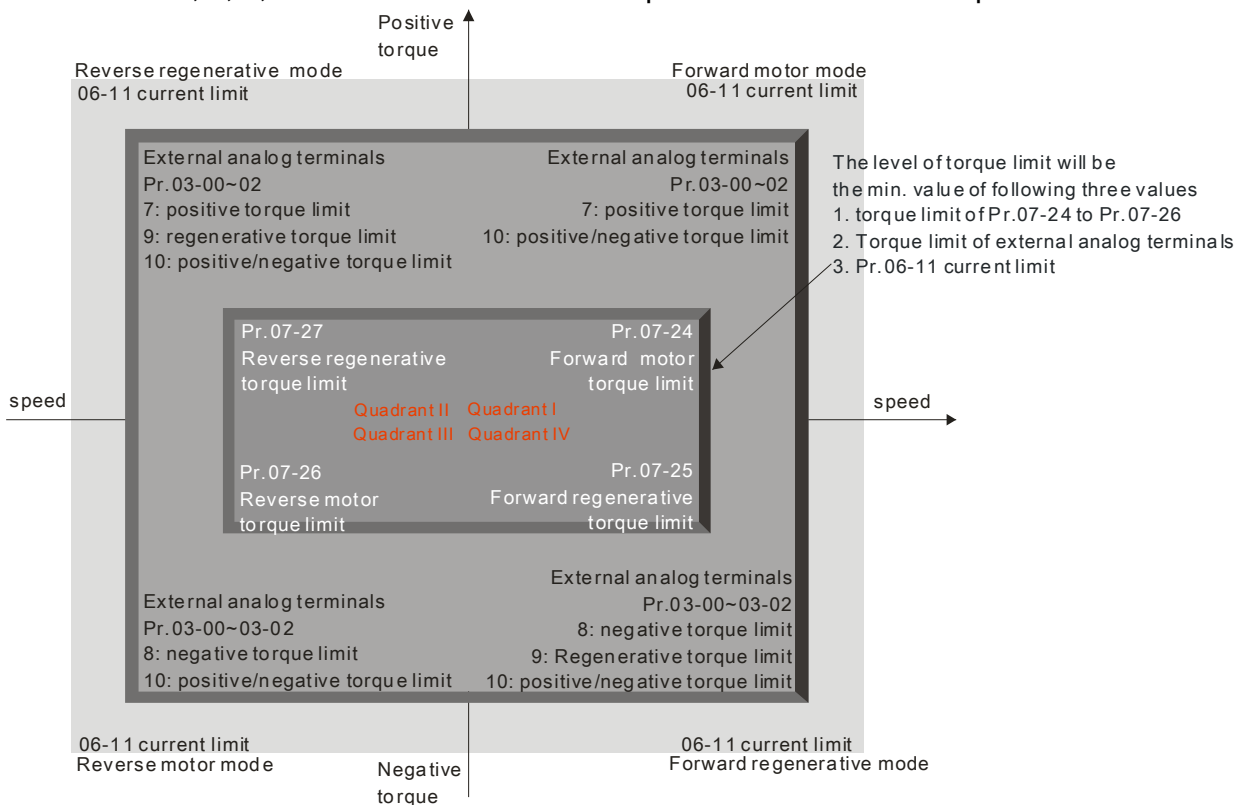

07-28 ⚡ Emergency Stop (EF) & Forced Stop Selection

Control mode	VF	VFPG	FOCPM	Factory Setting: 0
Settings			0 Coast to stop	
			1 By deceleration Time 1	
			2 By deceleration Time 2	
			3 By deceleration Time 3	
			4 By deceleration Time 4	
			5 By Pr.01-31	

📖 When the multi-function input terminal is set to 10 or 14 and it is ON, the brushless DC motor drive will be operated by Pr.07-28.

07-29 ⚡ Time for Decreasing Torque at Stop

Control mode	FOCPM	Factory Setting: 0.000
Settings	0.000 to 1.000 sec	

📖 When the drive stop output it will produce the noise from the reacting force between the motor and the mechanical brake. This parameter can be used to decrease this reacting force and lower the noise.

📖 It is used to set the time for decreasing torque to 0%.
RUN/STOP

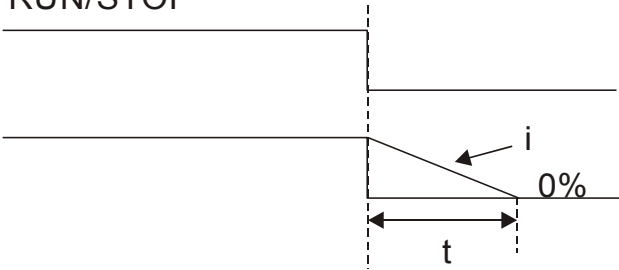

$$\frac{i}{00-01} \times \frac{100\%}{300\%} \times (07-29) = t$$

Group 8 PM Parameters

↗ This parameter can be set during operation.

08-00 Motor Auto Tuning**Control mode** FOCPM

Factory setting: 0

Settings	Description
0	No function
1	Only for the unloaded motor, auto measure the angle between magnetic pole and PG origin (Pr. 08-09)
2	For PM parameters
3	Auto measure the angle between magnetic pole and PG origin (Pr. 08-09)



For setting=1: It can auto measure the angle between magnetic pole and PG origin. Please notice the following items when measuring:

1. Please unload before tuning.
2. If brake is controlled by drive, the drive will act by the normal operation to finish tuning after wiring and setting brake control parameters.
3. If brake is controlled by the host controller, it needs to make sure that brake is in release state before tuning.



For setting=2: Starting auto tuning by pressing RUN key and it will write the measure value into Pr.08-05, Pr.08-07 (Rs, Lq).

The steps to AUTO-Tuning are: (Dynamic measure)

1. Make sure that all the parameters are set to factory settings and the motor wiring is correct.
2. Motor: Fill in Pr.08-01, Pr.08-02, Pr.08-03 and Pr.08-04 with correct values. Refer to motor capacity to set accel./decel. time.
3. When Pr.08-00 is set to 2, the brushless DC motor drive will execute auto-tuning immediately after receiving a "RUN" command. (NOTE: the motor will run! The shaft needs to be locked with external force.)
4. After executing, please check if all values are filled in Pr.08-05 and Pr.08-07.



For setting=3: It can auto measure the angle between magnetic pole and PG origin. Please notice the following items when measuring:

1. It can be loaded motor or unloaded motor before tuning.
2. If brake is controlled by drive, the drive will act by the normal operation to finish tuning after wiring and setting brake control parameters.
3. If brake is controlled by the host controller, it needs to make sure that brake is in release state before tuning.
4. Please ensure Encoder Input Type Setting (Pr.10-02) is accurate. A false setting would affect the position detection of magnetic pole and cause inaccurate angle between Magnetic Pole and PG Origin (Pr.08-09).



- The rated speed can't be larger or equal to 120f/p.
- Please notice that if the electromagnetic valve and brake is not controlled by the brushless DC motor drive, please release it by manual.
- It is recommended to set Pr.08-00 to 1 (unloaded motor) for the accurate calculation. If it needs to execute this function with loaded motor, please balance the carriage before execution.
- if it doesn't allow balancing the carriage in the measured environment, it can set Pr.08-00=3 for executing this function. It can execute this function with loaded motor by setting Pr.08-00=3. It will have a difference of 15~30° by the different encoder type.
- It will display the warning message "Auto tuning" on the digital keypad during measuring until the measure is finished. Then, the result will be saved into Pr.08-09.
- It will display "Auto Tuning Err" on the keypad when stopping by the fault of the brushless DC motor drive or human factor to show the failed detection. At this moment, please check the connections of the wirings of the brushless DC motor drives. If it displays "PG Fbk Error" on the digital keypad, please change the setting of Pr.10-02 (if it is set to 1, please change it to 2). If it displays "PG Fbk Loss" on the digital keypad, please check the feedback of Z-phase pulse.

08-01 Full-load Current of Motor

Control mode FOCPM Factory setting: #.##

Settings (40 to 120%)*Pr.00-01 Amps

This value should be set according to the rated frequency of the motor as indicated on the motor nameplate. The factory setting is 90% X rated current.
 Example: if the rated current for 7.5hp (5.5kW) models is 25A and the factory setting is 22.5A. In this way, the current range will be from 10A (25*40%) to 30A (25*120%).

08-02 Rated Power of Motor

Control mode FOCPM Factory setting: #.##

Settings 0.00 to 655.35 kW

It is used to set rated power of the motor. The factory setting is the power of the drive.

08-03 Rated Speed of Motor (rpm)

Control mode FOCPM Factory setting: 1710

Settings 0 to 65535Ω



It is used to set the rated speed of the motor and need to set according to the value indicated on the motor nameplate.

08-04	Number of Motor Poles	
Control mode	FOCPM	Factory setting: 4
	Settings	2 to 96



It is used to set the number of motor poles (must be an even number).

08-05	Rs of Motor	
Control mode	FOCPM	Factory setting: #
	Settings	0.000~65.535Ω

08-06	Ld of Motor	
Control mode	FOCPM	Factory setting: #

08-07	Lq of Motor	
Control mode	FOCPM	Factory setting: #
	Settings	0.0~6553.5mH

08-08	Back Electromotive Force	
Control mode	FOCPM	Factory setting: #
	Settings	0.0~6553.5Vrms



This parameter is used to set back electromotive force (phase-phase RMS value) when the motor is operated in the rated speed.



It can get RMS value by Pr.08-00=2 (Motor Auto Tuning).



08-09	Angle between Magnetic Pole and PG Origin	
Control mode	FOCPM	Factory setting: 360.0
	Settings	0.0~360.0°



This function is used to measure the angle between magnetic pole and PG origin.

08-10 Magnetic Pole Re-orientation

Control mode	FOCPM			Factory setting: 0
	Settings	0	Disable	
		1	Enable	

-  Please use with Pr.11-00 bit15=1.
-  This function is used for searching magnetic pole position and only for permanent magnet motor.
-  When it doesn't have origin-adjustment for encoder (Pr.08-09 is 360.0), it can only ensure that the motor operation efficiency can be up to 86% of the best efficiency. In this situation, when the operation efficiency needs to be improved, user can re-power on or set Pr.08-10 to 1 to get the magnetic pole orientation.

Group 9: Communication Parameters ⚡ This parameter can be set during operation.

When the brushless DC motor drive is controlled by RS-485 serial communication, a converter, VFD-USB01 or IFD8500, should be connected between the brushless DC motor drive and PC.

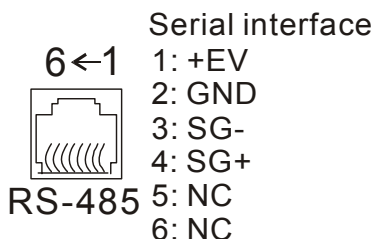

09-00 ⚡ Communication Address

Control mode		Factory Setting: 1
Settings	1 to 254	

📖 If the brushless DC motor drive is controlled by RS-485 serial communication, the communication address for this drive must be set via this parameter. And the communication address for each brushless DC motor drive must be different and unique.

09-01 ⚡ Transmission Speed

Control mode	VF	VFPG	FOCPM		Factory Setting: 9.6
Settings	4.8 to 115.2kbits/s				

📖 This parameter is used to set the transmission speed between the RS485 master (PLC, PC, etc.) and brushless DC motor drive.

09-02 ⚡ Transmission Fault Treatment

Control mode	VF	VFPG	FOCPM		Factory Setting: 3
Settings	0	Warn and keep operating			
	1	Warn and RAMP to stop			
	2	Reserved			
	3	No action and no display			

📖 This parameter is set to how to react if transmission errors occur.

09-03 ⚡ Time-out Detection

Control mode	VF	VFPG	FOCPM		Factory Setting: 0.0
Settings	0.0 ~ 100.0 sec (0.0: disable)				

📖 It is used to set the communication time-out time for the protocol and the keypad.

09-04 *↗* Communication Protocol

Control mode	VF	VFPG	FOCPM	Factory Setting: 1
Settings	0		Modbus ASCII mode, protocol <7,N,1>	
	1		Modbus ASCII mode, protocol <7,N,2>	
	2		Modbus ASCII mode, protocol <7,E,1>	
	3		Modbus ASCII mode, protocol <7,O,1>	
	4		Modbus ASCII mode, protocol <7,E,2>	
	5		Modbus ASCII mode, protocol <7,O,2>	
	6		Modbus ASCII mode, protocol <8,N,1>	
	7		Modbus ASCII mode, protocol <8,N,2>	
	8		Modbus ASCII mode, protocol <8,E,1>	
	9		Modbus ASCII mode, protocol <8,O,1>	
	10		Modbus ASCII mode, protocol <8,E,2>	
	11		Modbus ASCII mode, protocol <8,O,2>	
	12		Modbus RTU mode, protocol <8,N,1>	
	13		Modbus RTU mode, protocol <8,N,2>	
	14		Modbus RTU mode, protocol <8,E,1>	
	15		Modbus RTU mode, protocol <8,O,1>	
	16		Modbus RTU mode, protocol <8,E,2>	
	17		Modbus RTU mode, protocol <8,O,2>	

 Computer Control /Computer Link

 Before using RS-485 Serial Interface, each drive needs to pre-assign a communication address specified by Pr.9-00. The computer then controls each brushless DC drive according to its communication address

 A BLD-E1 can be set up to communicate in MODBUS networking using ASCII mode(American Standard Code for Information Interchange), each 8-bit data is a combination of 2 ASCII character. For example, a 1-byte data: 64Hex, shown as '64' in ASCII, consists of '6' (36Hex) and '4' (34Hex).

1. Code Description:

ASCII mode:

Each 8-bit data is the combination of two ASCII character. For example, a 1-byte data:

64 Hex, shown as '64' in ASCII, consists of '6' (36Hex) and '4' (34Hex).

Character	'0'	'1'	'2'	'3'	'4'	'5'	'6'	'7'
ASCII code	30H	31H	32H	33H	34H	35H	36H	37H

Character	'8'	'9'	'A'	'B'	'C'	'D'	'E'	'F'
ASCII code	38H	39H	41H	42H	43H	44H	45H	46H



2. Data Format

10-bit character frame (For ASCII):

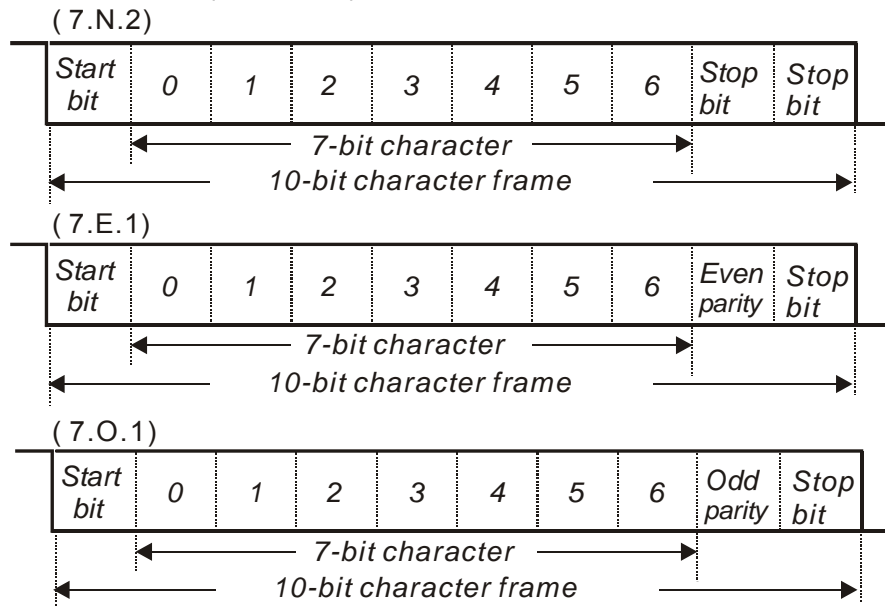

11-bit character frame (For RTU):

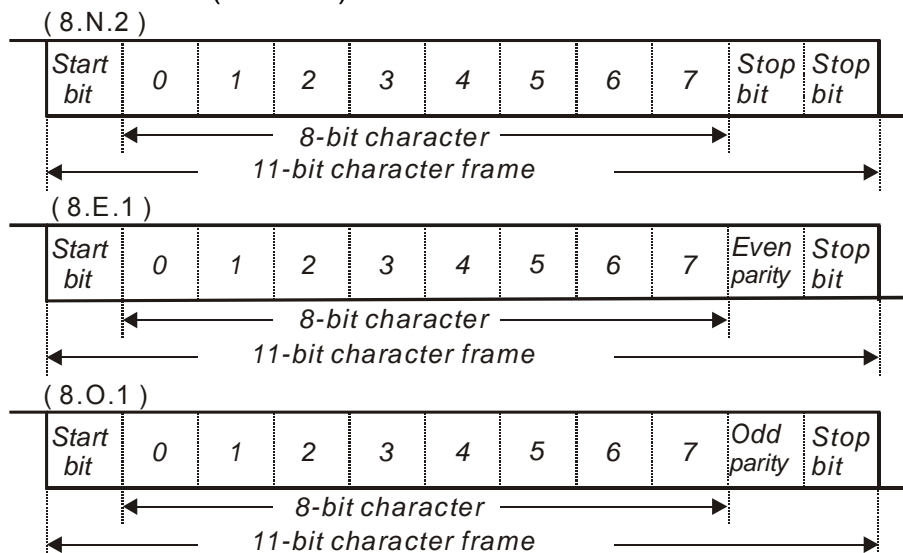

3. Communication Protocol

3.1 Communication Data Frame:

ASCII mode:

STX	Start character ':' (3AH)
Address Hi	Communication address: 8-bit address consists of 2 ASCII codes
Address Lo	
Function Hi	Command code: 8-bit command consists of 2 ASCII codes
Function Lo	
DATA (n-1) to DATA 0	Contents of data: Nx8-bit data consist of 2n ASCII codes n<=16, maximum of 32 ASCII codes
LRC CHK Hi	LRC check sum: 8-bit check sum consists of 2 ASCII codes
LRC CHK Lo	
END Hi	End characters: END1= CR (0DH), END0= LF(0AH)
END Lo	

RTU mode:

START	A silent interval of more than 10 ms
Address	Communication address: 8-bit address
Function	Command code: 8-bit command
DATA (n-1) to DATA 0	Contents of data: n×8-bit data, n<=16
CRC CHK Low	CRC check sum: 16-bit check sum consists of 2 8-bit characters
CRC CHK High	
END	A silent interval of more than 10 ms

3.2 Address (Communication Address)

00H: broadcast to all brushless DC drives

01H: brushless DC drive of address 01

0FH: brushless DC drive of address 15

10H: brushless DC drive of address 16

:

3.3 Function (Function code) and DATA (data characters)

The format of data characters depends on the function code.

03H: read data from register

06H: write single register

Example: reading continuous 2 data from register address 2102H, register address is 01H.

ASCII mode:

Command message:

STX	‘:’
Address	‘0’
	‘1’
Function	‘0’
	‘3’
Starting data address	‘2’
	‘1’
	‘0’
	‘2’
Number of data (count by word)	‘0’
	‘0’
	‘0’
	‘2’
LRC Check	‘D’
	‘7’
END	CR
	LF

Response message:

STX	‘:’
Address	‘0’
	‘1’
Function	‘0’
	‘3’
Number of data (Count by byte)	‘0’
	‘4’
Content of starting address 2102H	‘1’
	‘7’
	‘7’
	‘0’
Content of address 2103H	‘0’
	‘0’
	‘0’
	‘0’
LRC Check	‘7’
	‘1’
END	CR

Command message:

Response message:

	LF
--	----

RTU mode:

Command message:

Address	01H
Function	03H
Starting data address	21H
	02H
Number of data (count by word)	00H
	02H
CRC CHK Low	6FH
CRC CHK High	F7H

Response message:

Address	01H
Function	03H
Number of data (count by byte)	04H
Content of address 2102H	17H
	70H
Content of address 2103H	00H
	00H
CRC CHK Low	FEH
CRC CHK High	5CH

(2) 06H: single write, write single data to register.

Example: writing data 6000(1770H) to register 0100H. AMD address is 01H.

ASCII mode:

Command message:

STX	‘:’
Address	‘0’
	‘1’
Function	‘0’
	‘6’
Data address	‘0’
	‘1’
	‘0’
Data content	‘1’
	‘7’
	‘7’
	‘0’
LRC Check	‘7’
	‘1’
END	CR
	LF

Response message:

STX	‘:’
Address	‘0’
	‘1’
Function	‘0’
	‘6’
Data address	‘0’
	‘1’
	‘0’
Data content	‘1’
	‘7’
	‘7’
	‘0’
LRC Check	‘7’
	‘1’
END	CR
	LF

RTU mode:

Command message:

Address	01H
Function	06H
Data address	01H
	00H
Data content	17H
	70H
CRC CHK Low	86H
CRC CHK High	22H

Response message:

Address	01H
Function	06H
Data address	01H
	00H
Data content	17H
	70H
CRC CHK Low	86H
CRC CHK High	22H

(3) 10H: write multiple registers (write multiple data to registers)

Example: Set the multi-step speed,

Pr.04-00=50.00 (1388H), Pr.04-01=40.00 (0FA0H). AC drive address is 01H.

ASCII Mode:

Command message:

STX	‘.’
Address 1	‘0’
Address 0	‘1’
Function 1	‘1’
Function 0	‘0’
Starting data address	‘0’
	‘5’
	‘0’
	‘0’
Number of data (count by word)	‘0’
	‘0’
	‘0’
	‘2’
Number of data (count by byte)	‘0’
	‘4’
The first data content	‘1’
	‘3’
	‘8’
	‘8’
The second data content	‘0’
	‘F’
	‘A’
LRC Check	‘0’
	‘9’
END	‘A’
	CR
	LF

Response message:

STX	‘.’
Address 1	‘0’
Address 0	‘1’
Function 1	‘1’
Function 0	‘0’
Starting data address	‘0’
	‘5’
	‘0’
	‘0’
Number of data (count by word)	‘0’
	‘0’
	‘0’
	‘2’
LRC Check	‘E’
	‘8’
END	CR
	LF

RTU mode:

Command message:

Address	01H
Function	10H
Starting data address	05H
Starting data address	00H
Number of data (count by word)	00H’
	02H
	04
Number of data (count by byte)	04
	04
The first data content	13H
	88H
The second data content	0FH
	A0H
CRC Check Low	‘9’
CRC Check High	‘A’

Response message:

Address	01H
Function	10H
Starting data address	05H
Starting data address	00H
Number of data (count by word)	00H
	02H
	02H
CRC Check Low	41H
CRC Check High	04H

3.4 Check sum

ASCII mode:

LRC (Longitudinal Redundancy Check) is calculated by summing up, module 256, the values of the bytes from ADR1 to last data character then calculating the hexadecimal representation of the 2's-complement negation of the sum.

For example, reading 1 word from address 0401H of the AC drive with address 01H.

STX	‘.’
Address 1	‘0’
Address 0	‘1’
Function 1	‘0’
Function 0	‘3’
Starting data address	‘0’
	‘4’
	‘0’
	‘1’
Number of data	‘0’
	‘0’
	‘0’
	‘1’
LRC Check 1	‘F’
LRC Check 0	‘6’
END 1	CR
END 0	LF

$01H+03H+04H+01H+00H+01H=0AH$, the 2's-complement negation of 0AH is **F6H**.

RTU mode:

Address	01H
Function	03H
Starting data address	21H
	02H
Number of data (count by word)	00H
	02H
CRC CHK Low	6FH
CRC CHK High	F7H

CRC (Cyclical Redundancy Check) is calculated by the following steps:

Step 1: Load a 16-bit register (called CRC register) with FFFFH.

Step 2: Exclusive OR the first 8-bit byte of the command message with the low order byte of the 16-bit CRC register, putting the result in the CRC register.

Step 3: Examine the LSB of CRC register.

Step 4: If the LSB of CRC register is 0, shift the CRC register one bit to the right with MSB zero filling, then repeat step 3. If the LSB of CRC register is 1, shift the CRC register one bit to the right with MSB zero filling, Exclusive OR the CRC register with the polynomial value A001H, then repeat step 3.

Step 5: Repeat step 3 and 4 until eight shifts have been performed. When this is done, a complete 8-bit byte will have been processed.

Step 6: Repeat step 2 to 5 for the next 8-bit byte of the command message. Continue doing this until all bytes have been processed. The final contents of the CRC register are the CRC value. When transmitting the CRC value in the message, the upper and lower bytes of the CRC value must be swapped, i.e. the lower order byte will be transmitted first.

The following is an example of CRC generation using C language. The function takes two arguments:

Unsigned char* data ← a pointer to the message buffer

Unsigned char length ← the quantity of bytes in the message buffer

The function returns the CRC value as a type of unsigned integer.

```
Unsigned int crc_chk(unsigned char* data, unsigned char length){
    int j;
    unsigned int reg_crc=0xFFFF;
    while(length--){
        reg_crc ^= *data++;
        for(j=0;j<8;j++){
            if(reg_crc & 0x01){ /* LSB(b0)=1 */
                reg_crc=(reg_crc>>1) ^ 0xA001;
            }else{
                reg_crc=reg_crc >>1;
            }
        }
    }
    return reg_crc;
}
```

3.5 Address list

The contents of available addresses are shown as below:

Content	Address	Function	
AC drive Parameters	GGnnH	GG means parameter group, nn means parameter number, for example, the address of Pr 4-01 is 0401H. Referencing to chapter 5 for the function of each parameter. When reading parameter by command code 03H, only one parameter can be read at one time.	
Command Write only	2000H	Bit 0-3	0: No function 1: Stop 2: Run 3: Jog + Run

Content	Address	Function	
Status monitor Read only		Bit 4-5	00B: No function 01B: FWD 10B: REV 11B: Change direction
		Bit 6-7	00B: 1st accel/decel 01B: 2nd accel/decel 10B: 3rd accel/decel 11B: 4th accel/decel
		Bit 8-11	Represented 16 step speeds.
		Bit 12	1: disable bit 06-11
		Bit 13~14	00B: No function
			01B: operated by digital keypad
			02B: operated by Pr.00-15 setting
			03B: change operation source
	Bit 15	Reserved	
	2001H	Frequency command	
	2002H	Bit 0	1: EF (external fault) on
		Bit 1	1: Reset
		Bit 2	1: B.B. ON
		Bit 3-15	Reserved
	2100H	Error code: refer to Pr.06-16 to Pr.06-21	
	2119H	Bit 0-Bit 1	00: Stop
			01: deceleration
			10: Ready for operation
			11: operation
		Bit 2	1: JOG command
		Bit 3-Bit 4	00: FWD command, FWD output
			01: FWD command, REV output
			10: REV command, FWD output
			11: Reserved
		Bit 5	Reserved
		Bit 6	Reserved
		Bit 7	Reserved
		Bit 8	1: Master frequency Controlled by communication interface
		Bit 9	1: Master frequency controlled by analog/external terminals signal
		Bit 10	1: Operation command controlled by communication interface
	Bit 11	1: Parameters have been locked	
	Bit 12	1: enable to copy parameter from keypad	
Bit 13-15	Reserved		
2102H	Frequency command (F)		
2103H	Output frequency (H)		
2104H	Output current (AXXX.X)		
2105H	DC-BUS Voltage (UXXX.X)		
2106H	Output voltage (EXXX.X)		
2107H	Current step number of Multi-Step Speed Operation		
2116H	Multi-function display (Pr.00-04)		

Content	Address	Function
	2120H	Frequency command when malfunction
	2121H	Output frequency when malfunction
	2122H	Output current when malfunction
	2123H	Motor frequency when malfunction
	2124H	Output voltage when malfunction
	2125H	DC-bus voltage when malfunction
	2126H	Output power when malfunction
	2127H	Output torque when malfunction
	2128H	IGBT Temperature of Power Module at Present Fault
	2129H	Input status of multi-function terminal when malfunction (format is the same as Pr.00-04=16)
	212AH	Output status of multi-function terminal when malfunction (format is the same as Pr.00-04=17)
	212BH	Drive status when malfunction (format is the same as 2119H)
	2201H	Pr.00-05 user-defined setting
	2203H	VR analog input (XXX.XX %)
	2204H	ACI analog input (XXX.XX %)
	2205H	AVI analog input (XXX.XX %)
	2206H	Display temperature of IGBT (°C)
	2207H	Reserved
	2208H	Digital input state
	2209H	Digital output state

3.6 Exception response:

The brushless DC motor drive is expected to return a normal response after receiving command messages from the master device. The following depicts the conditions when no normal response is replied to the master device.

The brushless DC motor drive does not receive the messages due to a communication error; thus, the brushless DC motor drive has no response. The master device will eventually process a timeout condition.

The brushless DC motor drive receives the messages without a communication error, but cannot handle them. An exception response will be returned to the master device and an error message "CExx" will be displayed on the keypad of brushless DC motor drive. The xx of "CExx" is a decimal code equal to the exception code that is described below.

In the exception response, the most significant bit of the original command code is set to 1, and an exception code which explains the condition that caused the exception is returned.

Example of an exception response of command code 06H and exception code 02H:

ASCII mode:		RTU mode:	
STX	‘:’	Address	01H
Address Low	‘0’	Function	86H
Address High	‘1’	Exception code	02H
Function Low	‘8’	CRC CHK Low	C3H
Function High	‘6’	CRC CHK High	A1H

Exception code	'0'
	'2'
LRC CHK Low LRC CHK High	'7'
	'7'
END 1	CR
END 0	LF

The explanation of exception codes:

Exception code	Explanation
01	Illegal function code: The function code received in the command message is not available for the brushless DC motor drive.
02	Illegal data address: The data address received in the command message is not available for the brushless DC motor drive.
03	Illegal data value: The data value received in the command message is not available for the brushless DC motor drive.
04	Slave device failure: The brushless DC motor drive is unable to perform the requested action.
10	Communication time-out: If Pr.09-03 is not equal to 0.0, Pr.09-02=0~1, and there is no communication on the bus during the Time Out detection period (set by Pr.09-03), "cE10" will be shown on the keypad.

09-05 ⚡ Response Delay Time

Control mode VF VFPG FOCPM

Factory Setting: 2.0

Settings 0.0 ~ 200.0 ms



This parameter is the response delay time after AC drive receives communication command as shown in the following.

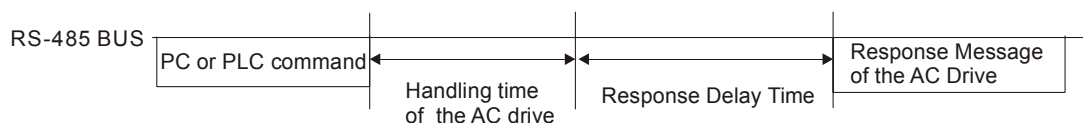

Chapter 4 ParametersAT [Troubleshooting] | BLD-E1 Series
 Group 10 Speed Feedback Control Parameters

✎ This parameter can be set during operation.

In this section, Adjust Speed Regulator is abbreviated as ASR and Pulse Generator as PG.

10-00 Encoder Type				Factory Setting: 3
Control mode	VFPG	FOCPG	TQCPG	FOCPM
Settings		0	No function	
		1	ABZ	
		2	ABZ+UVW	
		3	AB+PWM	

 Detection of the magnetic pole:
 Setting 1: The brushless DC motor drive will output short circuit to detect the position of the magnetic pole. At this moment, the motor will generate a little noise.
 Setting 2: The brushless DC motor drive will detect the position of the magnetic pole by the UVW signal of encoder.
 Setting 3: The brushless DC motor drive will detect the position of the magnetic pole by the sine signal of encoder.

10-01 Encoder Pulse				Factory Setting: 256
Control mode	VFPG	FOCPM		
Settings		1 to 25000		

 A Pulse Generator (PG) or encoder is used as a sensor that provides a feedback signal of the motor speed. This parameter defines the number of pulses for each cycle of the PG control.

10-02 Encoder Input Type Setting				Factory Setting: 0
Control mode	VFPG	FOCPM		
Settings		0	Disable	
		1	Phase A leads in a forward run command and phase B leads in a reverse run command	

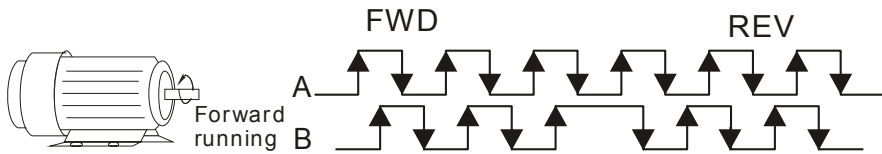

Phase B leads in a forward run command and phase A leads in a reverse run command

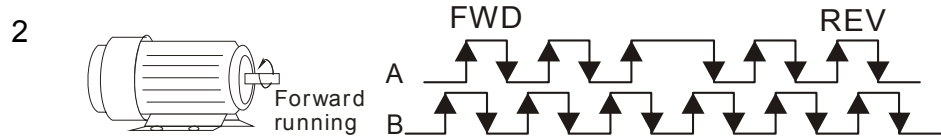

Phase A is a pulse input and phase B is a direction input. (low input=reverse direction, high input=forward direction)

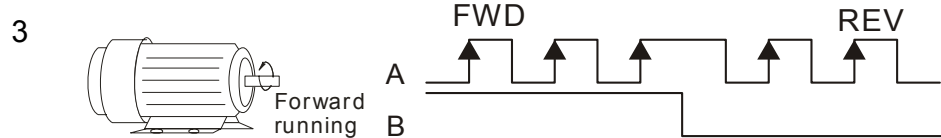

It is helpful for the stable control by inputting correct pulse type.

10-03 Encoder Feedback Fault Treatment (PGF1, PGF2)

Control mode	VFPG		Factory Setting: 2
Settings	0	Warn and keep operation	
	1	Warn and RAMP to stop	
	2	Warn and stop operation	

10-04 Detection Time for Encoder Feedback Fault

Control mode	VFPG FOCPM	Factory Setting: 3.0
Settings	0.0 to 10.0 sec	

When PG loss, encoder signal error, pulse signal setting error or signal error, if time exceeds the detection time for encoder feedback fault (Pr.10-04), the PG signal error will occur. Refer to the Pr.10-03 for encoder feedback fault treatment.

10-05 Encoder Stall Level (PGF3)

Control mode	VFPG FOCPM	Factory Setting: 115
Settings	0 to 120%	
	0: disable	

This parameter determines the maximum encoder feedback signal allowed before a fault occurs. (max. output frequency Pr.01-00 =100%)

10-06 Encoder Stall Detection Time

Control mode	VFPG FOCPM	Factory Setting: 0.1
Settings	0.0 to 2.0 sec	

 This parameter determines the maximum encoder feedback signal allowed before a fault occurs. (max. output frequency Pr.01-00 =100%)

10-07	↗ Encoder Slip Range (PGF4)		
Control mode	VFPG	FOCPM	Factory Setting: 50
	Settings	0 to 50% (0: disable)	

 This parameter determines the maximum encoder feedback signal allowed before a fault occurs. (max. output frequency Pr.01-00 =100%)

10-08	↗ Encoder Slip Detection Time		
Control mode	VFPG	FOCPM	Factory Setting: 0.5
	Settings	0.0 to 10.0 sec	

 This parameter determines the maximum encoder feedback signal allowed before a fault occurs. (max. output frequency Pr.01-00 =100%)

10-09	↗ Encoder Stall and Slip Error Treatment		
Control mode	VFPG	FOCPM	Factory Setting: 2
	Settings	0	Warn and keep operating
		1	Warn and RAMP to stop
		2	Warn and COAST to stop

 This parameter determines the maximum encoder feedback signal allowed before a fault occurs. (max. output frequency Pr.01-00 =100%)

 When the value of (rotation speed – motor frequency) exceeds Pr.10-07 setting, detection time exceeds Pr.10-08 or motor frequency exceeds Pr.10-05 setting, it will start to accumulate time. If detection time exceeds Pr.10-06, the encoder feedback signal error will occur. Refer to Pr.10-09 encoder stall and slip error treatment.

10-10	Mode Selection for UVW Input		
Control mode	VFPG	FOCPM	Factory Setting: 0
	Settings	0	Z signal is at the falling edge of U-phase
		1	Z signal is at the rising edge of U-phase

 Setting 0: when the operation is U->V->W, Z signal is at the falling edge of U-phase.
Setting 1: when the operation is U->V->W, Z signal is at the rising edge of U-phase.

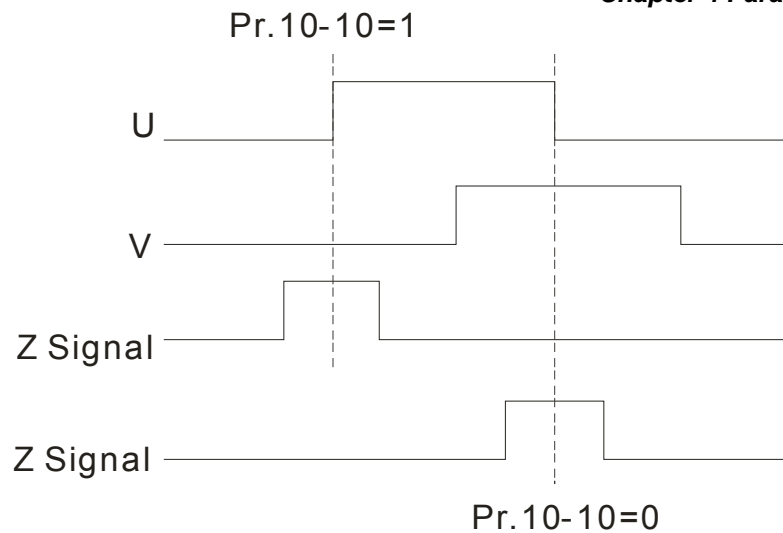

10-11	↗ ASR (Auto Speed Regulation) Control (P) of Zero Speed			
Control mode	VF	VFPG	FOCPM	Factory Setting: 100.0
Settings	0.0 to 500.0%			
10-12	↗ ASR (Auto Speed Regulation) Control (I) of Zero Speed			
Control mode	VF	VFPG	FOCPM	Factory Setting: 0.200
Settings	0.000 to 10.000 sec			
10-13	↗ ASR (Auto Speed Regulation) control (P) 1			
Control mode	VF	VFPG	FOCPM	Factory Setting: 100.0
Settings	0.0 to 500.0%			
10-14	↗ ASR (Auto Speed Regulation) control (I) 1			
Control mode	VF	VFPG	FOCPM	Factory Setting: 0.200
Settings	0.000 to 10.000 sec			
10-15	↗ ASR (Auto Speed Regulation) control (P) 2			
Control mode	VF	VFPG	FOCPM	Factory Setting: 100.0
Settings	0.0 to 500.0%			
10-16	↗ ASR (Auto Speed Regulation) control (I) 2			
Control mode	VF	VFPG	FOCPM	Factory Setting: 0.200
Settings	0.000 to 10.000 sec			
10-17	↗ ASR 1/ASR2 Switch Frequency			

Control mode	VF	VFP	FOCPM	Factory Setting: 84
Settings		0 to 4800rpm		
		0: disable		

- ASR P determines Proportional control and associated gain (P). ASR I determines integral control and associated gain (I).
- When integral time is set to 0, it is disabled. Pr.10-17 defines the switch frequency for the ASR1 (Pr.10-13, Pr.10-14) and ASR2 (Pr.10-15, Pr.10-16).

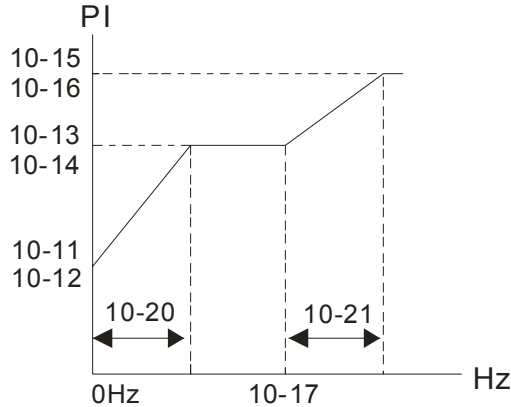

- When using multi-function input terminals to switch ASR1/ASR2, the diagram will be shown as follows.

Setting multi-function input terminal to 17 (ASR1/ASR2 switch)

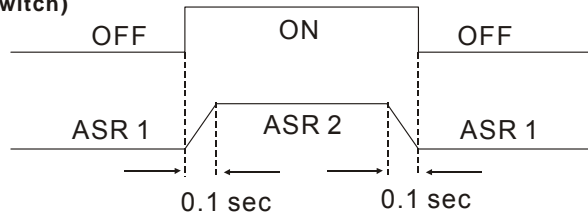

10-18 / ASR Primary Low Pass Filter Gain

Control mode	VF	VFP	FOCPM	Factory Setting: 0.008
Settings		0.000 to 0.350 sec		

- It defines the filter time of the ASR command.
- When setting to 1, this function is disabled.

10-19 / Zero Speed Gain (P)

Control mode	FOCPM	Factory Setting: 80.00
Settings	0.00 to 655.00%	

- When Pr.11-00 is set to Bit 7=1, Pr.10-19 is valid.

10-20 / Zero Speed/ASR1 Width Adjustment

Control mode	VFPG FOCPM	Factory Setting: 60
Settings	0 to 4800rpm	

10-21 / ASR1/ASR2 Width Adjustment

Control mode	VFPG FOCPM	Factory Setting: 60
Settings	0 to 4800rpm	



These two parameters are used to decide width of slope of ASR command during zero speed to low speed or Pr.10-17 to high speed.

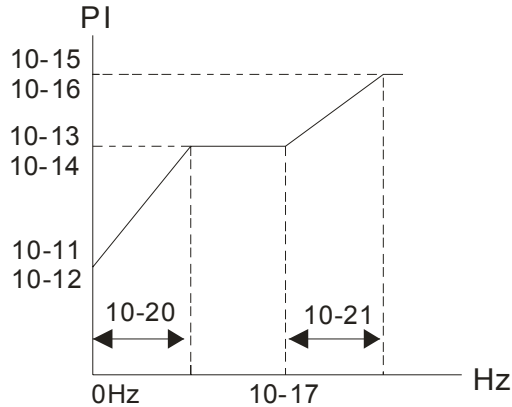

10-22 / Operation Time of Zero Speed

Control mode	FOCPM	Factory Setting: 0.250
Settings	0.001 to 65.535sec	

10-23 / Filter Time of Zero Speed

Control mode	FOCPM	Factory Setting: 0.004
Settings	0.001 to 65.535sec	

Group 11 Advanced Parameters

✎ This parameter can be set during operation.

11-00	System Control		
Control mode	VF	FOCPG	FOCPM
			Factory Setting: 0
	Settings	Bit 7=1	When position control is enabled, it doesn't need to set Pr.07-02 (DC Brake Current Level)
		Bit 15=0	when power is applied, it will detect the position of magnetic pole again
11-01	Reserved		
11-02	Reserved		
11-03	Reserved		
11-04	Reserved		
11-05	Reserved		
11-06	✎ Zero-speed Bandwidth		
Control mode	FOCPM		Factory Setting: 10
	Settings	0 to 40Hz	
11-07	✎ Low-speed Bandwidth		
Control mode	FOCPM		Factory Setting: 10
	Settings	0 to 40 Hz	
11-08	✎ High-speed Bandwidth		
Control mode	FOCPM		Factory Setting: 10
	Settings	0 to 40Hz	
	After estimating inertia and set Pr.11-00=1 (auto tuning), user can adjust parameters Pr.11-06, 11-07 and 11-08 separately by speed response. The larger number you set, the faster response you will get. Pr.10-08 is the switch frequency for low-speed/high-speed bandwidth.		
11-09	✎ Reserved		
11-10	✎ Reserved		
11-11	✎ Reserved		
11-12	✎ Reserved		
11-13	✎ Reserved		

11-14 ↗ Reserved

11-15 ↗ Reserved

11-16 ↗ PDF Gain Value

Control mode	VF	VFP	FOCPM	Factory Setting: 0
	Settings		0X0000~0XFFFF	

Group 12 User-defined Parameters

✎ This parameter can be set during operation.

In the following, it shows the factory setting of Pr.12-00 to Pr.12-29. You can change the setting as required.

12-00	✎ Present Fault Record			
Control mode	VF	VFP	FOCPM	Factory Setting: ###
	Setting	0616		

12-01	✎ Present Fault Time of Motor Operation (min.)			
Control mode	VF	VFP	FOCPM	Factory Setting: ###
	Setting	0632		

12-02	✎ Present Fault Time of Motor Operation (day)			
Control mode	VF	VFP	FOCPM	Factory Setting: ###
	Setting	0633		

12-03	✎ Frequency Command at Present Fault			
Control mode	VF	VFP	FOCPM	Factory Setting: ###
	Setting	2132		

12-04	✎ Output Frequency at Preset Fault			
Control mode	VF	VFP	FOCPM	Factory Setting: ###
	Setting	2133		

12-05	✎ Output Current at Present Fault			
Control mode	VF	VFP	FOCPM	Factory Setting: ###
	Setting	2134		

12-06	✎ Motor Frequency at Present Fault			
Control mode	VF	VFP	FOCPM	Factory Setting: ###
	Setting	2135		

12-07	↗ Output Voltage at Present Fault			
Control mode	VF	VFPG	FOCPM	Factory Setting: ###
	Setting	2136		
12-08	↗ DC-Bus Voltage at Present Fault			
Control mode	VF	VFPG	FOCPM	Factory Setting: ###
	Setting	2137		
12-09	↗ Output Power at Present Fault			
Control mode	VF	VFPG	FOCPM	Factory Setting: ###
	Setting	2138		
12-10	↗ Output Torque at Present Fault			
Control mode	VF	VFPG	FOCPM	Factory Setting: ###
	Setting	2139		
12-11	↗ IGBT Temperature of Power Module at Present Fault			
Control mode	VF	VFPG	FOCPM	Factory Setting: ###
	Setting	2140		
12-12	↗ Multi-function Terminal Input Status at Present Fault			
Control mode	VF	VFPG	FOCPM	Factory Setting: ###
	Setting	2141		
12-13	↗ Multi-function Terminal Output Status at Present Fault			
Control mode	VF	VFPG	FOCPM	Factory Setting: ###
	Setting	2142		
12-14	↗ Drive Status at Present Fault			
Control mode	VF	VFPG	FOCPM	Factory Setting: ###

Setting 2143

12-15 ⚡ Second Most Recent Fault Record

Control mode VF VFPG FOCPM Factory Setting: ###

Setting 0617

12-16 ⚡ Second Most Recent Fault Time of Motor Operation (min.)

Control mode VF VFPG FOCPM Factory Setting: ###

Setting 0634

12-17 ⚡ Second Most Recent Fault Time of Motor Operation (day)

Control mode VF VFPG FOCPM Factory Setting: ###

Setting 0635

12-18 ⚡ Third Most Recent Fault Record

Control mode VF VFPG FOCPM Factory Setting: ###

Setting 0618

12-19 ⚡ Third Most Recent Fault Time of Motor Operation (min.)

Control mode VF VFPG FOCPM Factory Setting: ###

Setting 0636

12-20 ⚡ Third Most Recent Fault Time of Motor Operation (day)

Control mode VF VFPG FOCPM Factory Setting: ###

Setting 0637

12-21 ⚡ Fourth Most Recent Fault Record

Control mode VF VFPG FOCPM Factory Setting: ###

Setting 0619

12-22	↗ Fourth Most Recent Fault Time of Motor Operation (min.)			
Control mode	VF	VFPG	FOCPM	Factory Setting: ###
	Setting	0638		
12-23	↗ Fourth Most Recent Fault Time of Motor Operation (day)			
Control mode	VF	VFPG	FOCPM	Factory Setting: ###
	Setting	0639		
12-24	↗ Fifth Most Recent Fault Record			
Control mode	VF	VFPG	FOCPM	Factory Setting: ###
	Setting	0620		
12-25	↗ Fifth Most Recent Fault Time of Motor Operation (min.)			
Control mode	VF	VFPG	FOCPM	Factory Setting: ###
	Setting	0640		
12-26	↗ Fifth Most Recent Fault Time of Motor Operation (day)			
Control mode	VF	VFPG	FOCPM	Factory Setting: ###
	Setting	0641		
12-27	↗ Sixth Most Recent Fault Record			
Control mode	VF	VFPG	FOCPM	Factory Setting: ###
	Setting	0621		
12-28	↗ Sixth Most Recent Fault Time of Motor Operation (min.)			
Control mode	VF	VFPG	FOCPM	Factory Setting: ###
	Setting	0642		

12-29	↘ Sixth Most Recent Fault Time of Motor Operation (day)			Factory Setting: ###
Control mode	VF	VFPG	FOCPM	
	Setting	0643		

12-30	↘ No Factory Setting		
12-31	↘ No Factory Setting		

12-00 12-31	↘ User-defined Parameters			Factory Setting: -
Control mode	VF	VFPG	FOCPM	
	Settings	-		

📖 Users can enter the parameters from group 0 to group 11 into group 12 (it can save 32 parameters). The saved value can also be the parameter addresses (but the hexadecimal value needs to be converted to decimal value).

📖 The setting method of 211BH

📖 Convert 211BH (hexadecimal) to decimal value:

$$\begin{array}{c}
 2 \ 1 \ 1 \ B \\
 \swarrow \quad \searrow \\
 \underline{1} \times 16^1 + \underline{11} \times 16^0 = 16 + 11 = 27 \quad \text{input } 2127
 \end{array}$$

Group 13 View User-defined Parameters

⚡ This parameter can be set during operation.

13-00 13-31	View User-defined Parameters			Factory Setting: -
Control mode	VF	VFPG	FOCPM	
Settings			-	



Refer to group 12 for details.

This page intentionally left blank

Chapter 5 Troubleshooting

5.1 Over Current (OC)

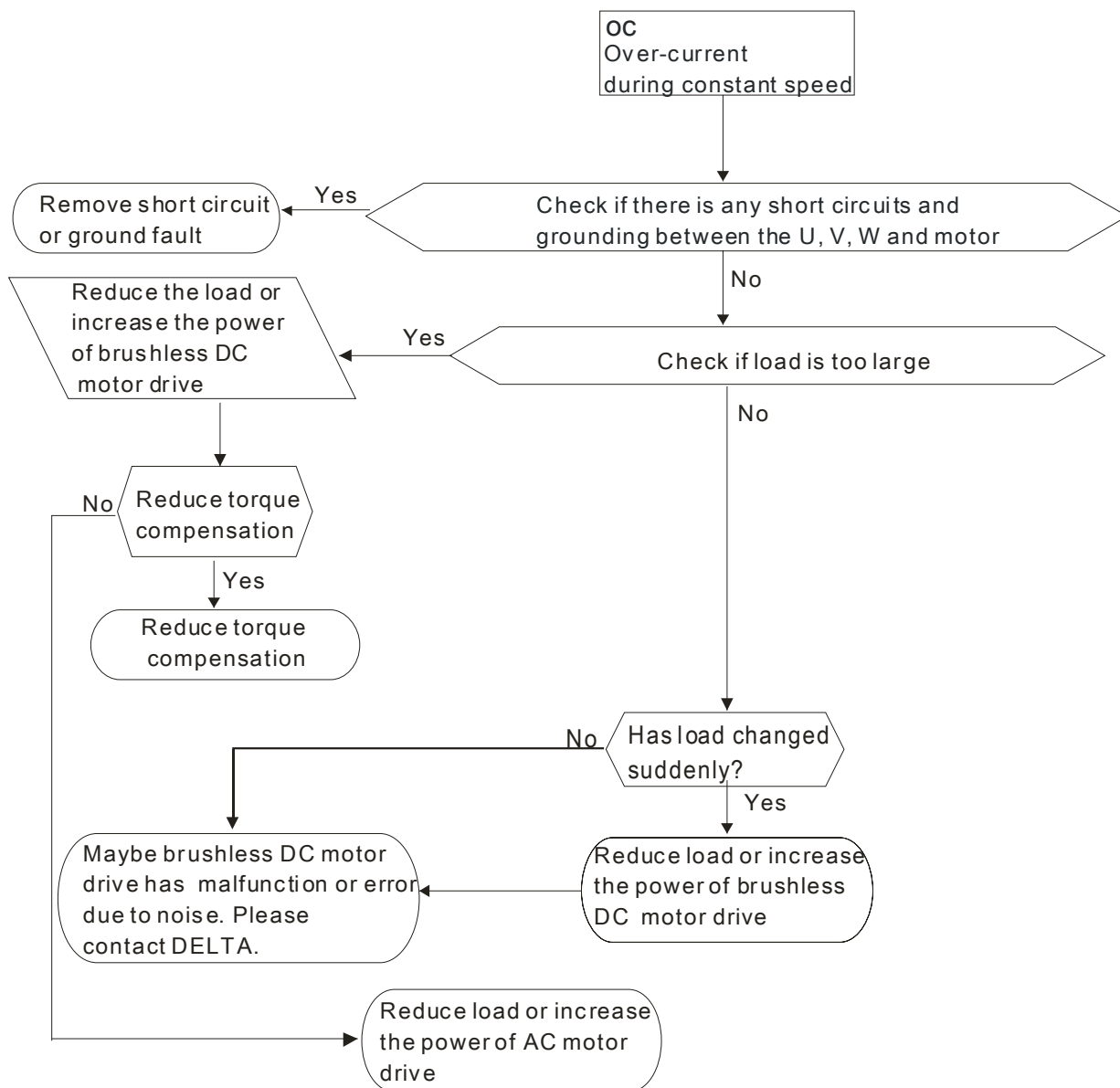

5.2 Ground Fault

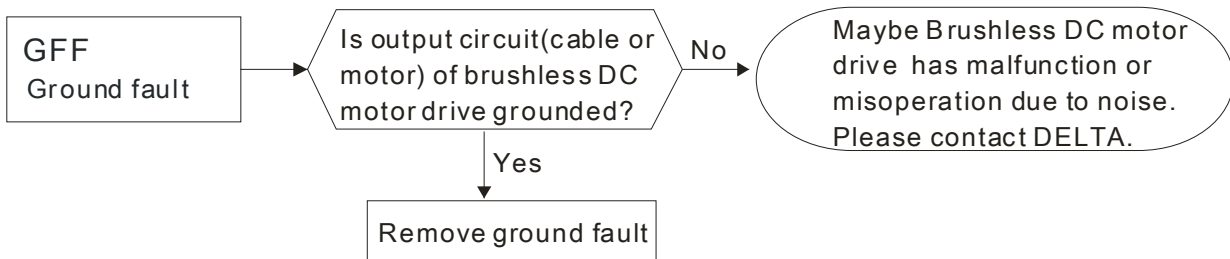

5.3 Over Voltage (OV)

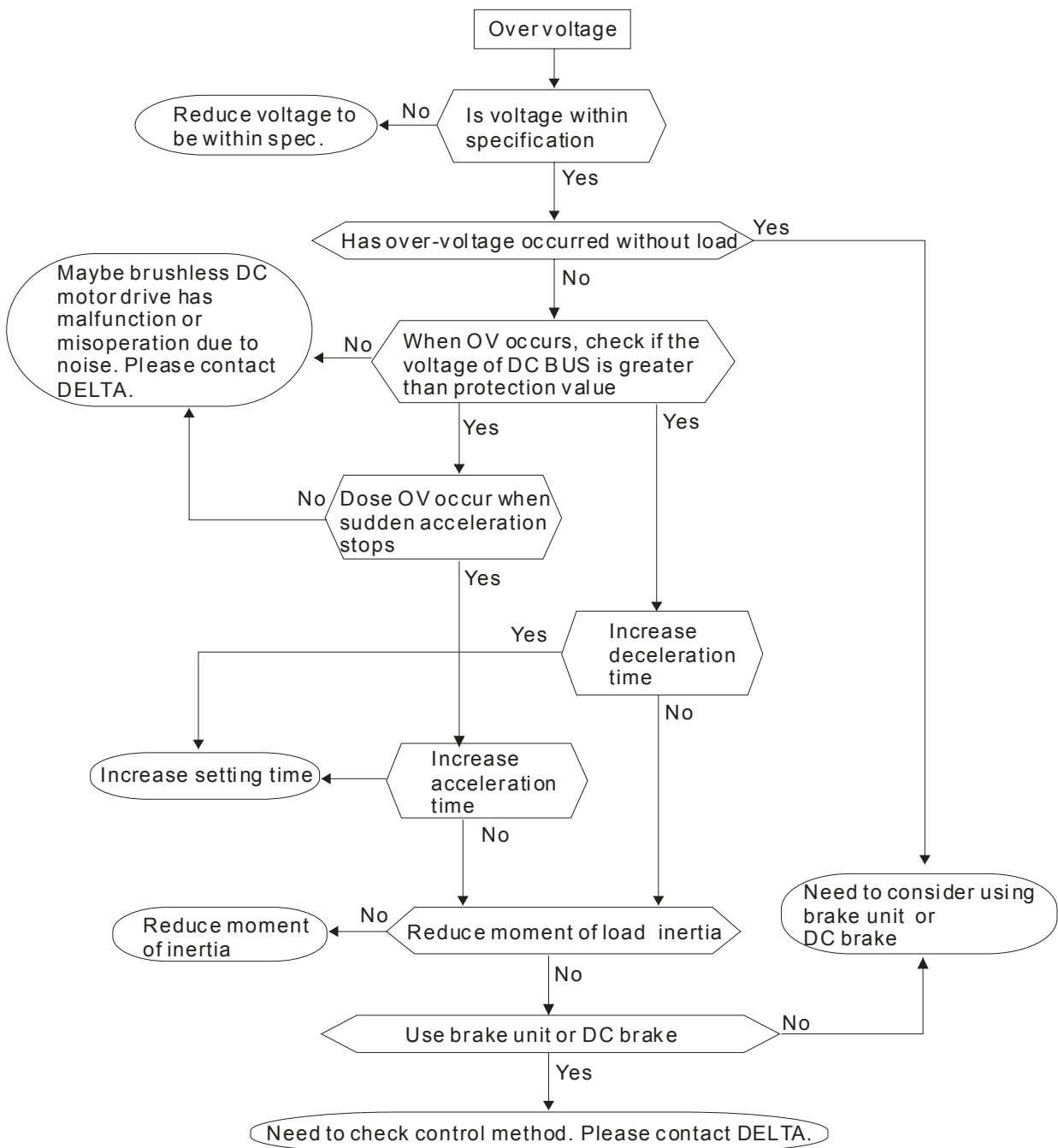

5.4 Low Voltage (Lv)

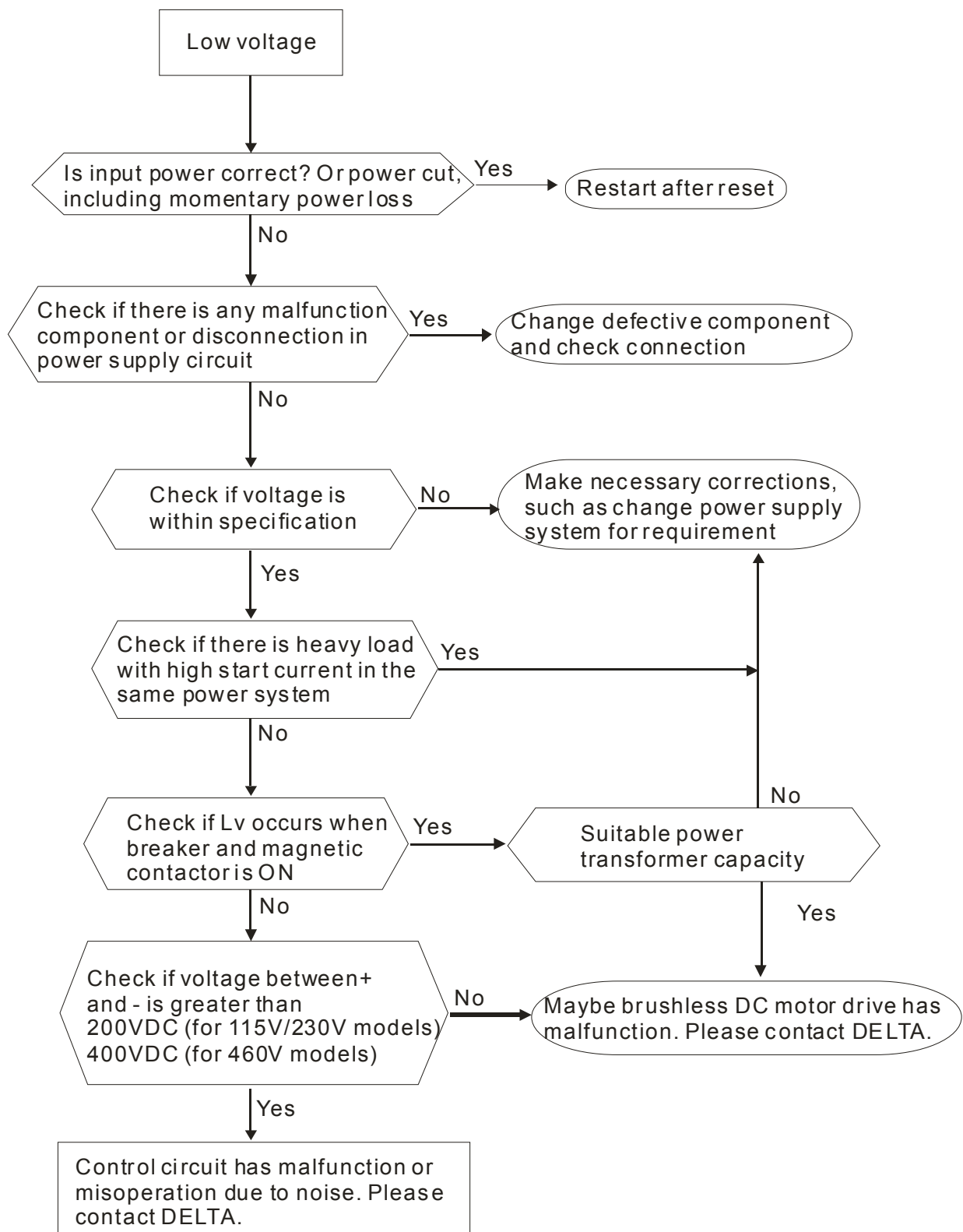

5.5 Over Heat (oH1)

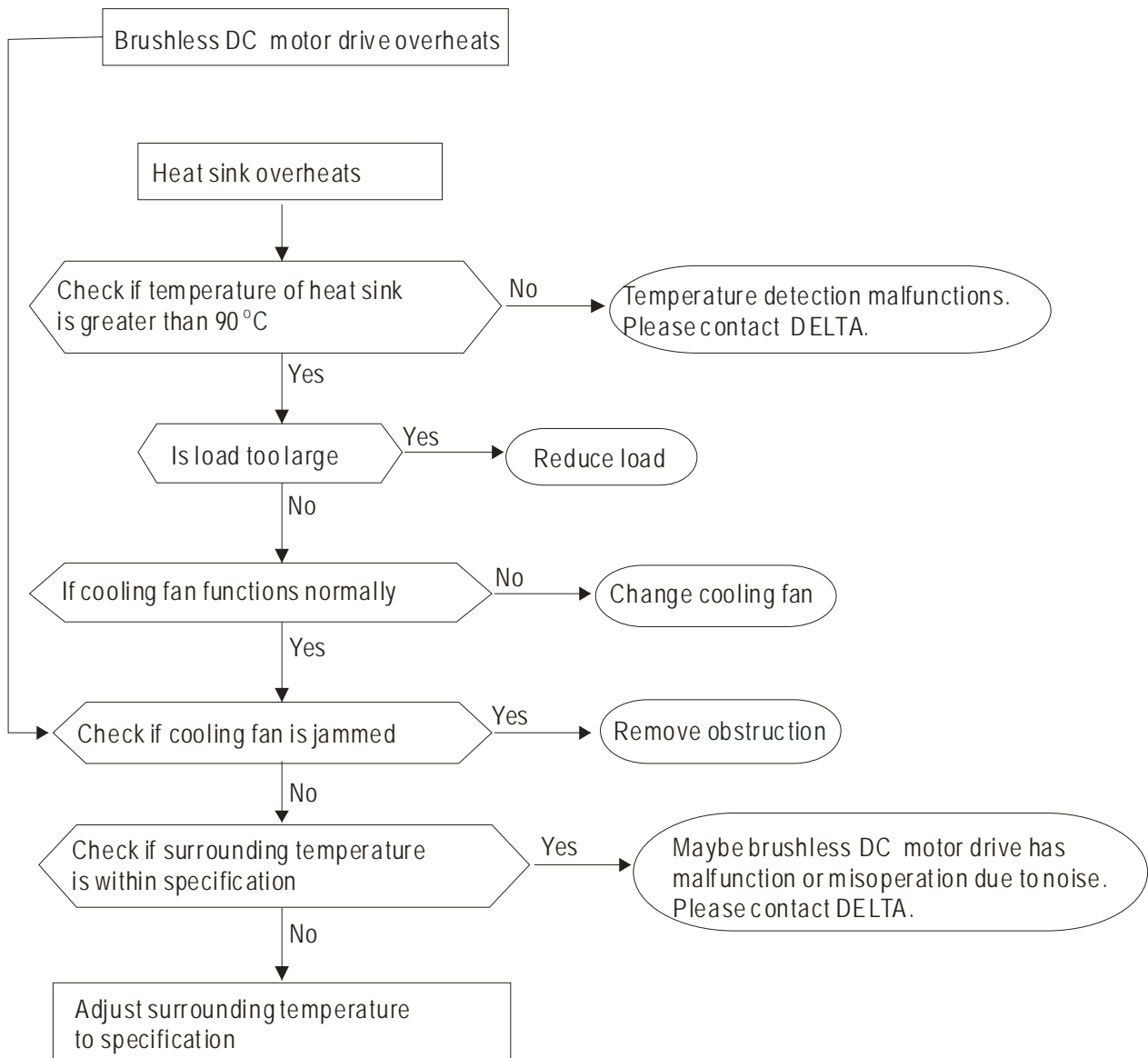

5.6 Overload

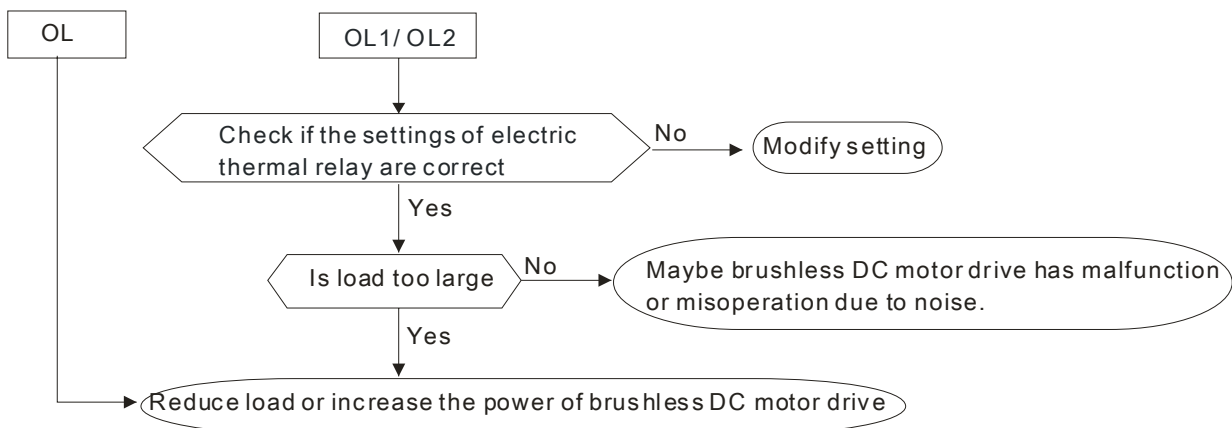

5.7 Keypad Display is Abnormal

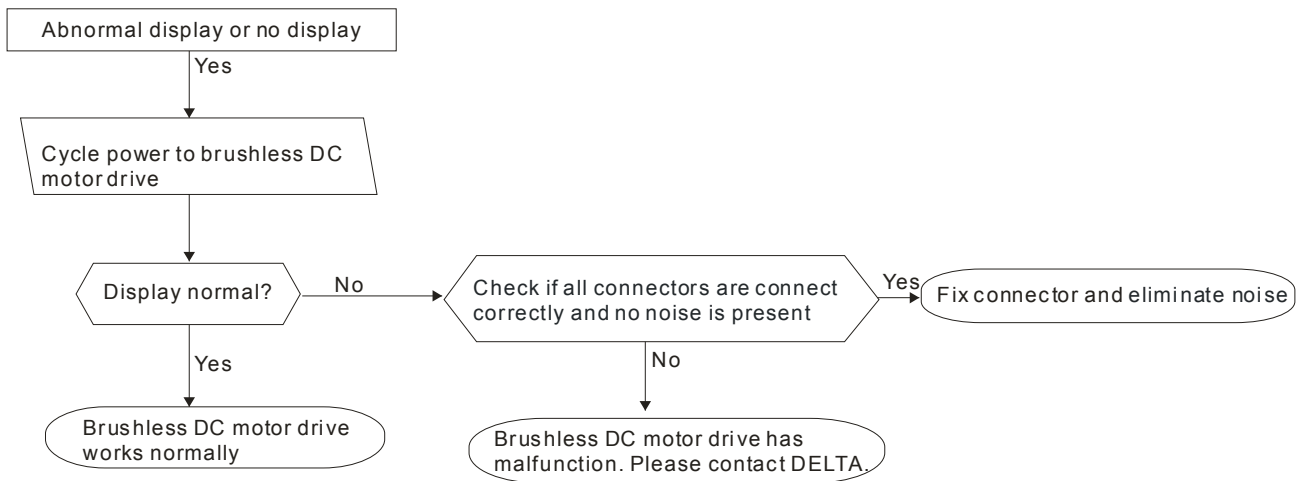

5.8 Phase Loss (PHL)

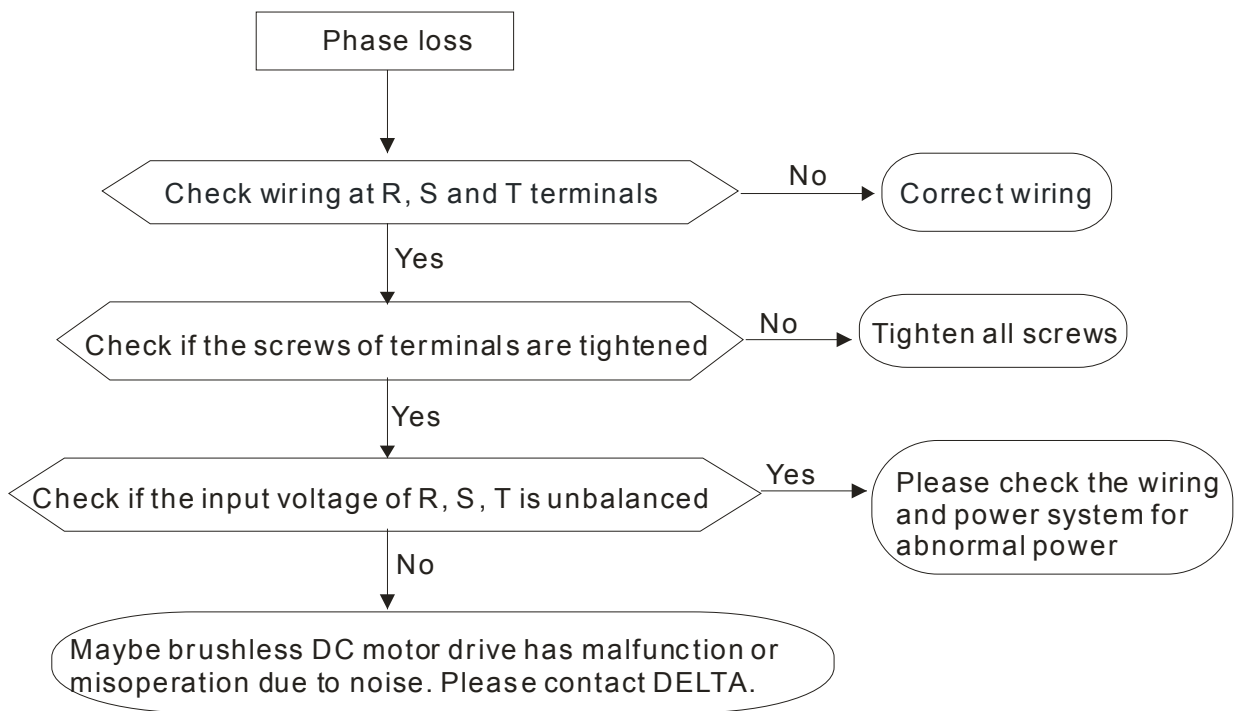

5.9 Motor cannot Run



5.10 Motor Speed cannot be Changed

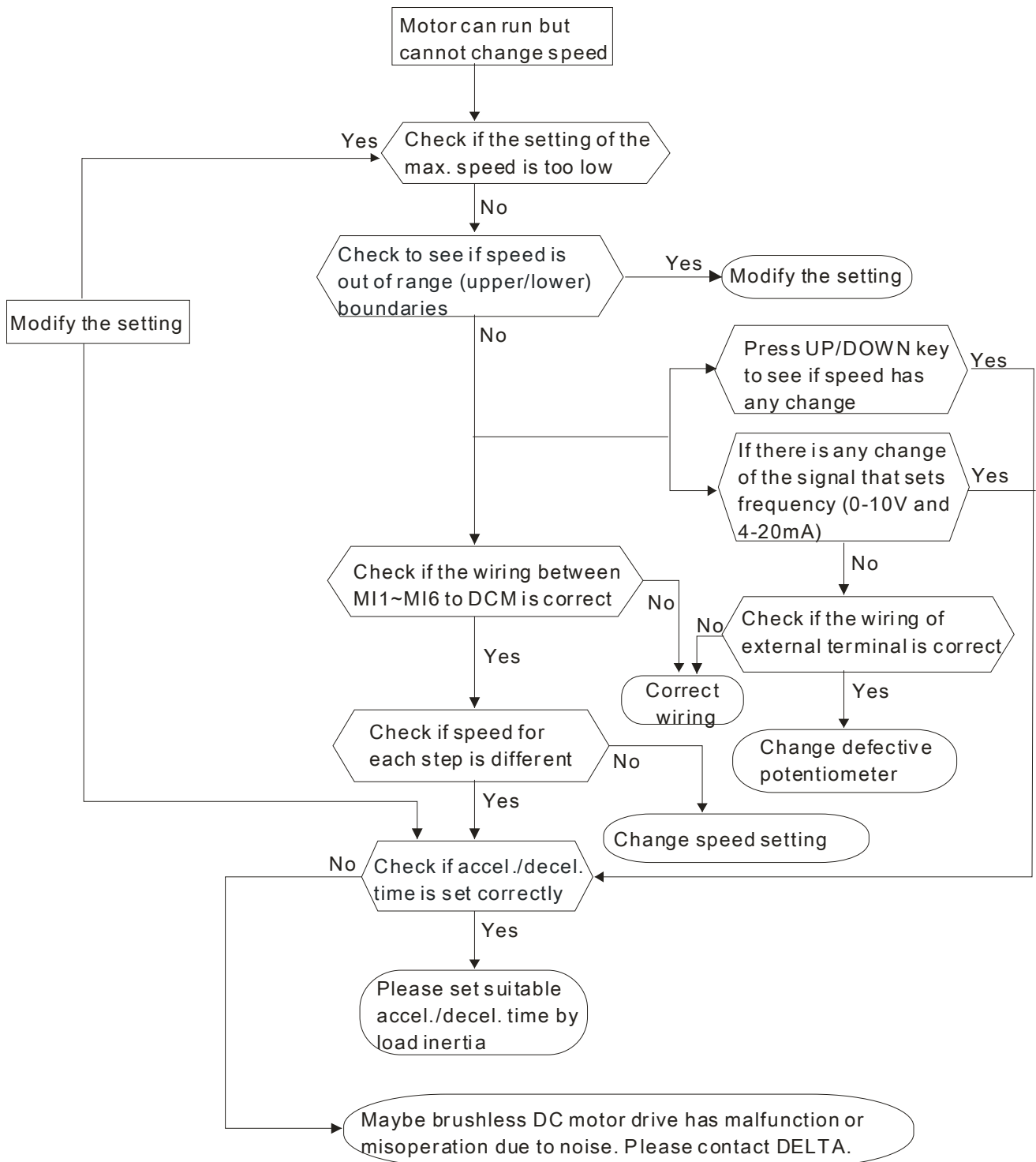

5.11 Motor Stalls during Acceleration

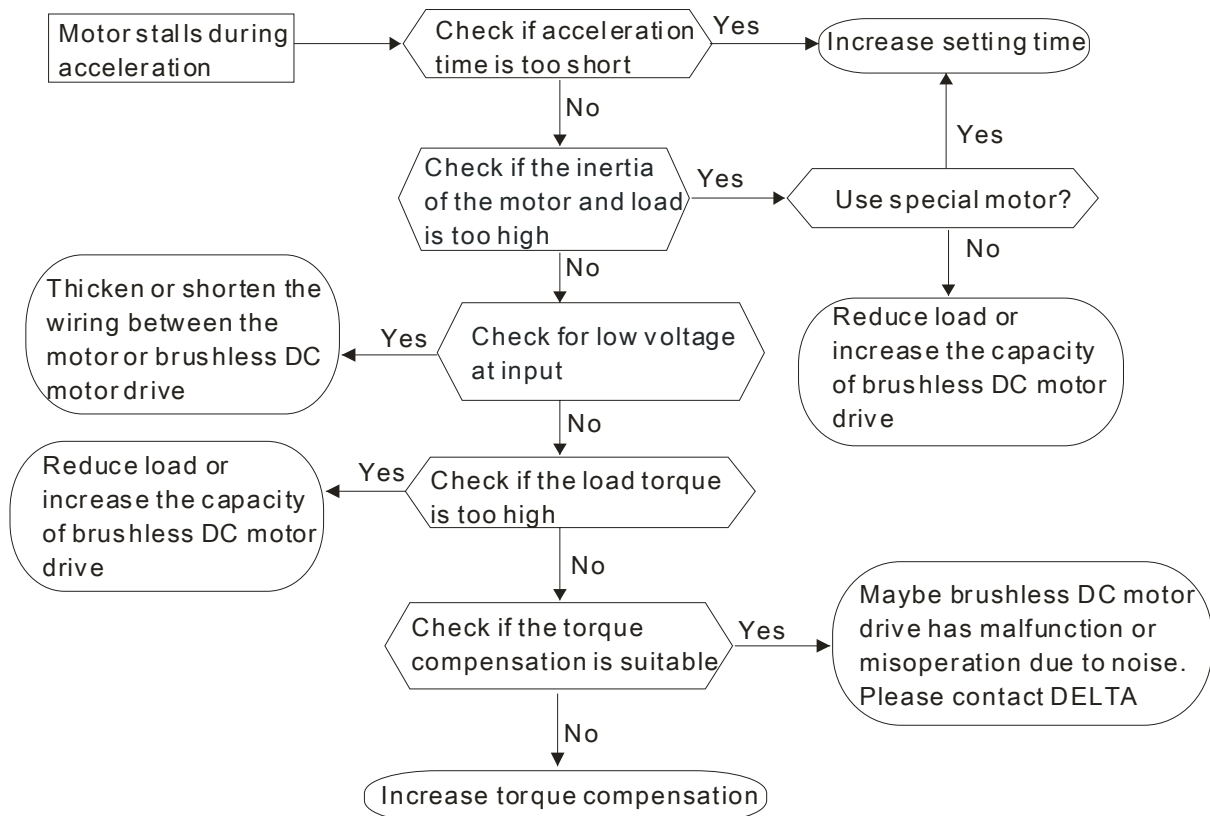

5.12 Electromagnetic/Induction Noise

Many sources of noise surround brushless DC motor drives and penetrate it by radiation or conduction. It may cause malfunction of the control circuits and even damage the brushless DC motor drive. Of course, there are solutions to increase the noise tolerance of a brushless DC motor drive. But this has its limits. Therefore, solving it from the outside as follows will be the best.

1. Add surge suppressor on the relays and contacts to suppress switching surges.
2. Shorten the wiring length of the control circuit or serial communication and keep them separated from the power circuit wiring.
3. Comply with the wiring regulations by using shielded wires and isolation amplifiers for long length.
4. The grounding terminal should comply with the local regulations and be grounded independently, i.e. not to have common ground with electric welding machines and other power equipment.
5. Connect a noise filter at the mains input terminal of the brushless DC motor drive to filter noise from the power circuit.

In short, solutions for electromagnetic noise exist of “no product”(disconnect disturbing equipment), “no spread”(limit emission for disturbing equipment) and “no receive”(enhance immunity).

5.13 Environmental Condition

Since the brushless DC motor drive is an electronic device, you should comply with the environmental conditions. Here are some remedial measures if necessary.

1. To prevent vibration, the use of anti-vibration dampers is the last choice. Vibrations must be within the specification. Vibration causes mechanical stress and it should not occur frequently, continuously or repeatedly to prevent damage to the brushless DC motor drive.
2. Store the brushless DC motor drive in a clean and dry location, free from corrosive fumes/dust to prevent corrosion and poor contacts. Poor insulation in a humid location can cause short-circuits. If necessary, install the brushless DC motor drive in a dust-proof and painted enclosure and in particular situations, use a completely sealed enclosure.
3. The ambient temperature should be within the specification. Too high or too low temperature will affect the lifetime and reliability. For semiconductor components, damage will occur once any specification is out of range. Therefore, it is necessary to periodically check air quality and the cooling fan and provide extra cooling of necessary. In addition, the microcomputer may not work in extremely low temperatures, making cabinet heating necessary.

4. Store within a relative humidity range of 0% to 90% and non-condensing environment. Please use an air conditioner and/or exsiccator when the brushless DC motor drive will not be used for a long time.

5.14 Affecting Other Machines

A brushless DC motor drive may affect the operation of other machines due to many reasons. Some solutions are:

■ High Harmonics at Power Side

High harmonics at power side during running can be improved by:

1. Separate the power system: use a transformer for the brushless DC motor drive.
2. Use a reactor at the power input terminal of the brushless DC motor drive.
3. If phase lead capacitors are used (never on the brushless DC motor drive output!!), use serial reactors to prevent damage to the capacitors damage from high harmonics.

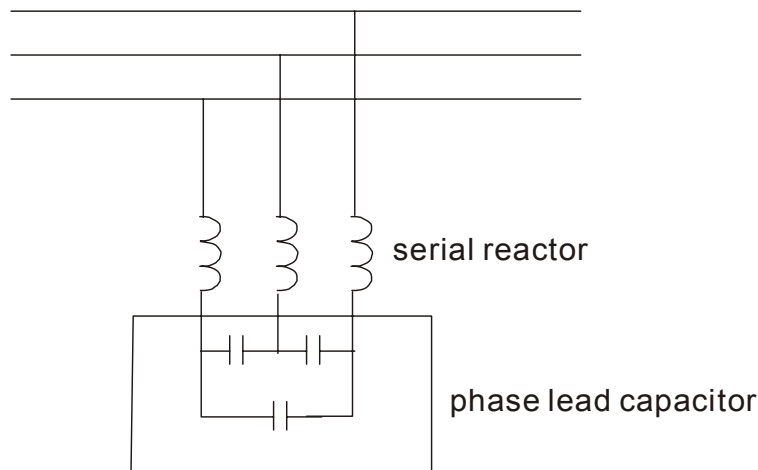

Chapter 6 Fault Code Information and Maintenance

6.1 Fault Code Information

The brushless DC motor drive has a comprehensive fault diagnostic system that includes several different alarms and fault messages. Once a fault is detected, the corresponding protective functions will be activated. The following faults are displayed as shown on the brushless DC motor drive digital keypad display. The five most recent faults can be read from the digital keypad or communication.

The brushless DC motor drive is made up of multiple components, including electric components (IC, resistor, capacitor and resistor), cooling fan and relay. These components have the life time and may cause malfunction when exceeding the life time. Therefore, it is necessary to have periodic inspection to find out antiquated components in time to keep the brushless DC motor drive in its optimal condition.

Please always perform a visual inspection and a check-up regularly for the brushless DC motor drive according to the following items to make sure that the brushless DC motor drive runs normally.



1. Wait 5 seconds after a fault has been cleared before performing reset via keypad of input terminal.
2. Before the check-up, always turn off the power and remove the cover. Wait at least 10 minutes for $\geq 30\text{kW}$ models (5 minutes for $\leq 22\text{kW}$) after all display lamps have gone out, and then confirm that the capacitors have fully discharged by measuring the voltage between $\oplus \sim \ominus$. It should be less than 25VDC.
3. Only qualified personnel can install, wire and maintain brushless DC motor drives. Please take off any metal objects, such as watches and rings, before operation. And only insulated tools are allowed.
4. Never reassemble internal components or wiring.
5. The operation characteristics and surrounding environment should comply with the specifications, such as no abnormal noise, vibration and smell.
6. Make sure that the keypad display is normal without overheat or color change.
7. Prevent static electricity.

6.1.1 Common Problems and Solutions

Fault Name	Fault Descriptions	Corrective Actions
ocA	<p>Over current during acceleration Output current exceeds triple of the rated current during acceleration.</p>	<ol style="list-style-type: none"> 1. Short-circuit at motor output: Check for possible poor insulation at the output line. 2. Deceleration Time too short: Increase the Deceleration Time. 3. Brushless DC motor drive output power is too small: Replace the brushless DC motor drive with the next higher power model.
ocD	<p>Over current during deceleration Output current exceeds triple of the rated current during deceleration.</p>	<ol style="list-style-type: none"> 1. Short-circuit at motor output: Check for possible poor insulation at the output line. 2. Deceleration Time too short: Increase the Deceleration Time. 3. Brushless DC motor drive output power is too small: Replace the brushless DC motor drive with the next higher power model.
ocn	<p>Over-current during steady state operation Output current exceeds triple of the rated current during constant speed.</p>	<ol style="list-style-type: none"> 1. Short-circuit at motor output: Check for possible poor insulation at the output line. 2. Deceleration Time too short: Increase the Deceleration Time. 3. Brushless DC motor drive output power is too small: Replace the brushless DC motor drive with the next higher power mode
GFF	<p>Ground fault When (one of) the output terminal(s) is grounded, short circuit current is more than 75% of brushless DC motor drive rated current, the brushless DC motor drive power module may be damaged</p> <p>NOTE: The short circuit protection is provided for brushless DC motor drive protection, not for protection of the user.</p>	<ol style="list-style-type: none"> 1. Check the wiring connections between the brushless DC motor drive and motor for possible short circuits, also to ground. 2. Check whether the IGBT power module is damaged. 3. Check for possible poor insulation at the output line.
ocS	<p>Over-current at stop</p>	Return to the factory

Fault Name	Fault Descriptions	Corrective Actions
OvA	DC BUS over-voltage during acceleration (230V: DC 405V; 460V: DC 810V)	<ol style="list-style-type: none"> 1. Check if the input voltage falls within the rated brushless DC motor drive input voltage range. 2. Check for possible voltage transients. 3. If DC BUS over-voltage due to regenerative voltage, please increase the Deceleration Time or add an optional brake resistor
OvD	DC BUS over-voltage during deceleration 230V: DC 405V; 460V: DC 810V	<ol style="list-style-type: none"> 1. Check if the input voltage falls within the rated brushless DC motor drive input voltage range. 2. Check for possible voltage transients. 3. If DC BUS over-voltage due to regenerative voltage, please increase the Deceleration Time or add an optional brake resistor
OvN	DC BUS over-voltage during constant speed 230V: DC 405V; 460V: DC 810V	<ol style="list-style-type: none"> 1. Check if the input voltage falls within the rated brushless DC motor drive input voltage range. 2. Check for possible voltage transients. 3. If DC BUS over-voltage due to regenerative voltage, please increase the Deceleration Time or add an optional brake resistor
OvS	DC BUS over-voltage at stop	<ol style="list-style-type: none"> 1. Check if the input voltage falls within the rated brushless DC motor drive input voltage range. 2. Check for possible voltage transients.
LVA	DC BUS voltage is less than Pr.06-00 during acceleration.	<ol style="list-style-type: none"> 1. Check if the input voltage is normal 2. Check for possible sudden load
LVD	DC BUS voltage is less than Pr.06-00 during deceleration	<ol style="list-style-type: none"> 1. Check if the input voltage is normal 2. Check for possible sudden load
LVN	DC BUS voltage is less than Pr.06-00 during constant speed.	<ol style="list-style-type: none"> 1. Check if the input voltage is normal 2. Check for possible sudden load
LVS	Low voltage at stop	<ol style="list-style-type: none"> 1. Check if the input voltage is normal 2. Check for possible sudden load
PHL	Phase loss	Check Power Source Input if all 3 input phases are connected without loose contacts.

Fault Name	Fault Descriptions	Corrective Actions
OH1	IGBT overheating IGBT temperature exceeds protection level 1 to 30HP: 100 °C	<ol style="list-style-type: none"> 1. Ensure that the ambient temperature falls within the specified temperature range. 2. Make sure that the ventilation holes are not obstructed. 3. Remove any objects from the heatsinks and check for possible dirty heat sink fins. 4. Check the fan and clean it. 5. Provide enough spacing for adequate ventilation.
EH10	IGBT overheating	Return to the factory
OL	Overload The brushless DC motor drive detects excessive drive output current. NOTE: The brushless DC motor drive can withstand up to 150% of the rated current for a maximum of 60 seconds.	<ol style="list-style-type: none"> 1. Check whether the motor is overloaded. 2. Take the next higher power brushless DC motor drive model.
EOL1	Motor 1 overload	<ol style="list-style-type: none"> 1. Check whether the motor is overloaded. 2. Check whether the rated current of motor (Pr.05-01) is suitable 3. Take the next higher power brushless DC motor drive model.
OL1	Electronic Thermal Relay 1 Protection	<ol style="list-style-type: none"> 1. Check whether the motor is overloaded. 2. Check whether motor rated current setting (Pr.05-01) is suitable 3. Check electronic thermal relay function (Pr.06-05~ Pr.06-07) 4. Take the next higher power brushless DC motor drive model.
OL2	Electronic Thermal Relay 2 Protection	<ol style="list-style-type: none"> 1. Check whether the motor is overloaded. 2. Check whether motor rated current setting (Pr.05-01) is suitable 3. Check electronic thermal relay function (Pr.06-05~ Pr.06-07) 4. Take the next higher power brushless DC motor drive model.

Fault Name	Fault Descriptions	Corrective Actions
cF1	Internal EEPROM can not be programmed.	<ol style="list-style-type: none"> 1. Press "RESET" key to the factory setting. 2. If Internal EEPROM still can not be programmed, return to the factory.
cF2	Internal EEPROM can not be read.	<ol style="list-style-type: none"> 1. Press "RESET" key to the factory setting. 2. If Internal EEPROM again can not be read, return to the factory.
cd0	Hardware failure in current detection	<ol style="list-style-type: none"> 1. Reapply the power. 2. If fault code is still displayed on the keypad, please return to the factory.
cd1	U-phase error	<ol style="list-style-type: none"> 1. Reapply the power. 2. If fault code is still displayed on the keypad, please return to the factory.
cd2	V-phase error	<ol style="list-style-type: none"> 1. Reapply the power. 2. If fault code is still displayed on the keypad, please return to the factory.
cd3	W-phase error	<ol style="list-style-type: none"> 1. Reapply the power. 2. If fault code is still displayed on the keypad, return to the factory.
Hd0	CC (current clamp)	<ol style="list-style-type: none"> 1. Reapply the power. 2. If fault code is still displayed on the keypad, return to the factory.
Hd1	OC hardware error	<ol style="list-style-type: none"> 1. Reapply the power. 2. If fault code is still displayed on the keypad, return to the factory.
Hd2	OV hardware error	<ol style="list-style-type: none"> 1. Reapply the power. 2. If fault code is still displayed on the keypad, return to the factory.
Hd3	GFF hardware error	<ol style="list-style-type: none"> 1. Reapply the power. 2. If fault code is still displayed on the keypad, return to the factory.
AUE	Auto tuning error	<ol style="list-style-type: none"> 1. Check cabling between drive and motor. 2. Check the motor capacity and parameters settings. 3. Retry

Fault Name	Fault Descriptions	Corrective Actions
PCF 1	PG feedback error	Check if Pr.10-01 is not set to 0 when it is PG feedback control.
PCF 2	PG feedback loss	Check the wiring of the PG feedback.
PCF 3	PG feedback stall	<ol style="list-style-type: none"> 1. Check the wiring of the PG feedback. 2. Check if the setting of PI gain and deceleration is suitable (Pr.10-05~Pr.10-06). 3. Return to the factory.
PCF 4	PG slip error	<ol style="list-style-type: none"> 1. Check the wiring of the PG feedback. 2. Check if the setting of PI gain and deceleration is suitable (Pr.10-07~Pr.10-08). 3. Return to the factory.
ACE	ACI loss	<ol style="list-style-type: none"> 1. Check the ACI wiring. 2. Check if the ACI signal is less than 4mA.
EF	External Fault	<ol style="list-style-type: none"> 1. Input EF (N.O.) on external terminal is closed to GND. Output U, V, W will be turned off. 2. Give RESET command after fault has been cleared.
EF 1	Emergency stop When the multi-function input terminals MI1 to MI6 are set to emergency stop and the brushless DC motor drive stops output.	Press RESET after fault has been cleared.
cE 1	Illegal function code The function code must be 03, 06, 10, 63	Check if the function code is correct.
cE 2	Illegal communication address Communication address for 0X2XX should be 0X2000 to 0X2005.	Check if the communication address is correct.
cE 3	Illegal data length Data length should be 1~20 characters	Check if the communication data length is correct.
cE 4	Illegal data value Communication address 0x2XXX, 0X22XX...etc. are read only	Check if the communication address is correct.
cE 10	Communication time-out (Pr.09-02~Pr.09-03)	Check if the wiring for the communication is correct.

Fault Name	Fault Descriptions	Corrective Actions
c P 10	Keypad communication time-out	<ol style="list-style-type: none"> 1. Check if the wiring for the communication is correct. 2. Check if there is any wrong with the keypad.

6.1.2 Reset

There are three methods to reset the brushless DC motor drive after solving the fault:

1. Press STOP/RESET key on keypad.
2. Set external terminal to "RESET" and then set to be ON.
3. Send "RESET" command by communication.



NOTE

Make sure that RUN command or signal is OFF before executing RESET to prevent damage or personal injury due to immediate operation.

6.2 Maintenance and Inspections

Before the check-up, always turn off the power and remove the cover. Wait at least 10 minutes after all display lamps have gone out, and then confirm that the capacitors have fully discharged by measuring the voltage between $\oplus \sim \ominus$. It should be less than 25VDC.

Ambient environment

Check Items	Methods and Criterion	Maintenance Period		
		Daily	Half Year	One Year
Check the ambient temperature, humidity, vibration and see if there are any dust, gas, oil or water drops	Visual inspection and measurement with equipment with standard specification	○		
Check if there are any dangerous objects in the environment	Visual inspection	○		

Voltage

Check Items	Methods and Criterion	Maintenance Period		
		Daily	Half Year	One Year
Check if the voltage of main circuit and control circuit is correct	Measure with multimeter with standard specification	<input type="radio"/>		

Keypad

Check Items	Methods and Criterion	Maintenance Period		
		Daily	Half Year	One Year
Is the display clear for reading?	Visual inspection	<input type="radio"/>		
Any missing characters?	Visual inspection	<input type="radio"/>		

Mechanical parts

Check Items	Methods and Criterion	Maintenance Period		
		Daily	Half Year	One Year
If there is any abnormal sound or vibration	Visual and aural inspection		<input type="radio"/>	
If there are any loose screws	Tighten the screws		<input type="radio"/>	
If any part is deformed or damaged	Visual inspection		<input type="radio"/>	
If there is any color change by overheating	Visual inspection		<input type="radio"/>	
If there is any dust or dirt	Visual inspection		<input type="radio"/>	

Main circuit

Check Items	Methods and Criterion	Maintenance Period		
		Daily	Half Year	One Year
If there are any loose or missing screws	Tighten or replace the screw	<input type="radio"/>		

If machine or insulator is deformed, cracked, damaged or with color change due to overheating or ageing	Visual inspection NOTE: Please ignore the color change of copper plate		<input type="radio"/>	
If there is any dust or dirt	Visual inspection		<input type="radio"/>	

Terminals and wiring of main circuit

Check Items	Methods and Criterion	Maintenance Period		
		Daily	Half Year	One Year
If the wiring shows change of color change or deformation due to overheat	Visual inspection		<input type="radio"/>	
If the insulation of wiring is damaged or the color has changed	Visual inspection		<input type="radio"/>	
If there is any damage	Visual inspection		<input type="radio"/>	

DC capacity of main circuit

Check Items	Methods and Criterion	Maintenance Period		
		Daily	Half Year	One Year
If there is any leakage of liquid, change of color, cracks or deformation	Visual inspection	<input type="radio"/>		
If the valve has come out? If the valve is enlarged?	Visual inspection	<input type="radio"/>		
Measure static capacity when required			<input type="radio"/>	

Resistor of main circuit

Check Items	Methods and Criterion	Maintenance Period		
		Daily	Half Year	One Year

Check Items	Methods and Criterion	Maintenance Period		
		Daily	Half Year	One Year
If there is any peculiar smell or insulator cracks due to overheating	Visual inspection, smell		○	
If there is any disconnection	Visual inspection		○	
If the connected terminal is normal?	Measure with multimeter with standard specification		○	

Transformer and reactor of main circuit

Check Items	Methods and Criterion	Maintenance Period		
		Daily	Half Year	One Year
If there is any abnormal vibration or peculiar smell	Visual inspection	○		

Magnetic contactor and relay of main circuit

Check Items	Methods and Criterion	Maintenance Period		
		Daily	Half Year	One Year
If there is any vibration noise during operation?	Aural inspection	○		
If the contact works correctly	Visual inspection	○		

Printed circuit board and connector of main circuit

Check Items	Methods and Criterion	Maintenance Period		
		Daily	Half Year	One Year
If there are any loose screws and connectors	Tighten the screws and press the connectors firmly in place.		○	
If there is any peculiar smell and color change	Visual inspection and smell		○	

Check Items	Methods and Criterion	Maintenance Period		
		Daily	Half Year	One Year
If there is any crack, damage, deformation or corrosion	Visual inspection		○	

Cooling fan of cooling system

Check Items	Methods and Criterion	Maintenance Period		
		Daily	Half Year	One Year
If there is any abnormal sound or vibration	Visual, aural inspection and turn the fan with hand (turn off the power before operation) to see if it rotates smoothly			○
If there is any loose screw	Tighten the screw			○
If there is any change of color due to overheating	Visual inspection			○

Ventilation channel of cooling system

Check Items	Methods and Criterion	Maintenance Period		
		Daily	Half Year	One Year
If there is any obstruction in the heat sink, air intake or air outlet	Aural inspection		○	

Appendix A Specifications

There are 115V, 230V and 460V models in the BLD-E1 series. For 115V models, it is 1-phase models. For 0.25 to 3HP of the 230V models, there are 1-phase/3-phase models. Refer to following specifications for details.

Voltage Class		115V Class		
Model Number BLD-XXXE1		002	004	007
Max. Applicable Motor Output (kW)		0.2	0.4	0.75
Max. Applicable Motor Output (hp)		0.25	0.5	1.0
Output Rating	Rated Output Capacity (kVA)	0.6	1.0	1.6
	Rated Output Current (A)	1.6	2.5	4.2
	Maximum Output Voltage (V)	3-Phase Proportional to Twice the Input Voltage		
	Output Speed (RPM)	1~4000 RPM		
	Carrier Frequency (kHz)	2-15		
Input Rating	Rated Input Current (A)	6.4	9	18
	Rated Voltage/Frequency	Single phase, 100-120V, 50/60Hz		
	Voltage Tolerance	± 10%(90~132 V)		
	Frequency Tolerance	± 5%(47~63 Hz)		
Cooling Method		Natural Cooling		Fan Cooling
Weight (kg)		1.1	1.1	1.4

Voltage Class		230V Class						
Model Number BLD-XXXE1		002	004	007	015	022	037	
Max. Applicable Motor Output (kW)		0.2	0.4	0.75	1.5	2.2	3.7	
Max. Applicable Motor Output (hp)		0.25	0.5	1.0	2.0	3.0	5.0	
Output Rating	Rated Output Capacity (kVA)	0.6	1.0	1.6	2.9	4.2	6.5	
	Rated Output Current (A)	1.6	2.5	4.2	7.5	11.0	17	
	Maximum Output Voltage (V)	3-Phase Proportional to Input Voltage						
	Output Speed (RPM)	1~4000RPM						
	Carrier Frequency (kHz)	2-15						
Input Rating	XXXE 121A	Rated Input Current (A)	4.9	6.5	9.3	15.7	24	--
		Rated Voltage/Frequency	Single 200-240 V, 50/60Hz					
	XXXE 123A	Rated Input Current (A)	1.9	2.7	4.9	9	15	20.6
		Rated Voltage/Frequency	3-phase 200-240V, 50/60Hz					
	Rated Voltage/Frequency		1-phase/3-phase 200-240V, 50/60Hz					3-phase 200-240V, 50/60Hz
	Voltage Tolerance		± 10%(180~264 V)					
Frequency Tolerance		± 5%(47~63 Hz)						
Cooling Method		Natural Cooling			Fan Cooling			
Weight (kg)		1.2	1.2	1.2	1.7	1.7	1.7	

Voltage Class		460V Class				
Model Number BLD-XXXE1		004	007	015	022	037
Max. Applicable Motor Output (kW)		0.4	0.75	1.5	2.2	3.7
Max. Applicable Motor Output (hp)		0.5	1.0	2.0	3.0	5.0
Output Rating	Rated Output Capacity (kVA)	1.2	2.0	3.3	4.4	6.8
	Rated Output Current (A)	1.5	2.5	4.2	5.5	8.2
	Maximum Output Voltage (V)	3-Phase Proportional to Input Voltage				
	Output Speed (RPM)	1 ~ 4000 RPM				
	Carrier Frequency (kHz)	2-15				
	Rated Input Current (A)	1.8	3.2	4.3	7.1	9.0
	Rated Voltage/Frequency	3-phase, 380-480V, 50/60Hz				
	Voltage Tolerance	± 10%(342~528V)				
	Frequency Tolerance	± 5%(47~63Hz)				
Cooling Method		Natural Cooling		Fan Cooling		
Weight (kg)		1.2	1.2	1.2	1.7	1.7

General Specifications			
Control Characteristics	Control System		Hall Sensor + 6-step close loop
	Speed Setting Resolution		1 RPM
	Output Speed Resolution		1 RPM
	Torque Characteristics		Including the auto-torque compensation; starting torque can be 150% at 80RPM
	Overload Endurance		150% of rated current for 1 minute
	Accel/Decel Time		0.1 to 600 seconds (2 Independent settings for Accel/Decel time)
	Stall Prevention Level		Setting 20 to 250% of rated current
	Regenerated Brake Torque		Approx. 20% (up to 125% possible with optional brake resistor or externally mounted brake unit)
Operating Characteristics	Speed Setting	Keypad	Setting by ▲ ▼
		External Signal	Potentiometer-5kΩ/0.5W, 0 to +10VDC, 4 to 20mA, RS-485 interface; Multi-function Inputs 3 to 6 (15 steps, up/down)
	Operation Setting Signal	Keypad	Set by RUN and STOP
		External Signal	2 wires/3 wires (MI1, MI2, MI3) and RS-485 serial interface
	Multi-function Input Signal		Multi-step selection 0 to 15, accel/decel inhibit, 2 accel/decel switches, counter, Jog, driver reset, UP/DOWN key settings, ACI/AVI selections, NPN/PNP input selection
Multi-function Output Indication		AC drive operating, speed attained, zero speed, counter attained indication, status selections of input terminals, fault indication, overheat alarm and emergency stop	
Protection Functions			Over voltage, over current, under voltage, external fault, motor overload, ground fault, drive overload and drive overheating

General Specifications		
Operation Functions	Built-in AVR, over-voltage/over-current stall prevention, 5 fault records, reverse inhibition, momentary power loss restart, auto torque compensation, adjustable carrier frequency, output speed limits, parameter reset, PID control, external counter, MODBUS communication, abnormal reset, abnormal re-start and NPN/PNP selection	
Display Keypad	6-key, 7-segment LED with 4-digit, 5 status LEDs, setting speed, display actual output speed, output current, custom units, parameter values for setup and lock, faults, RUN, STOP, RESET, FWD/REV	
Built-in EMI Filter	For 230V 1-phase and 460V 3-phase models.	
Environmental Conditions	Enclosure Rating	IP20
	Pollution Degree	2
	Installation Location	Altitude 1,000 m or lower, keep from corrosive gasses, liquid and dust
	Ambient Temperature	-10°C to 50°C (40°C for side-by-side mounting) Non-Condensing and not frozen
	Storage Temperature	-20 °C to 60 °C
	Ambient Humidity	Below 90% RH (non-condensing)
	Vibration	9.80665m/s ² (1G) less than 20Hz, 5.88m/s ² (0.6G) at 20 to 50Hz

This page intentionally left blank

Appendix B Accessories

B.1 All Brake Resistors & Brake Units Used in the Brushless DC Motor

Drive

Voltage	Applicable Motor		Full Load Torque KG-M	Equivalent Resistor Value to the Brushless DC Motor Drive	Brake Unit Part No.	Brake Resistors Part No. and Quantity		Brake Torque 10%ED %	Min. Equivalent Resistor Value for Each Brushless DC Motor Drive
	hp	kW							
115V Series	0.25	0.2	0.110	200W 250 Ω	BUE-20015	BR200W250	1	320	200 Ω
	0.5	0.4	0.216	200W 250 Ω	BUE-20015	BR200W250	1	170	100 Ω
	1	0.75	0.427	200W 150 Ω	BUE-20015	BR200W150	1	140	80 Ω
230V Series	0.25	0.2	0.110	200W 250 Ω	BUE-20015	BR080W200	1	320	200 Ω
	0.5	0.4	0.216	200W 250 Ω	BUE-20015	BR080W200	1	170	100 Ω
	1	0.75	0.427	200W 150 Ω	BUE-20015	BR300W100	1	140	80 Ω
	2	1.5	0.849	300W 85 Ω	BUE-20015	-		125	80 Ω
	3	2.2	1.262	*	*	*			
	5	3.7	2.080	*	*	*			
460V Series	0.5	0.4	0.216	300W 400 Ω	BUE-40015	BR300W400	1	400	400 Ω
	1	0.75	0.427	300W 400 Ω	BUE-40015	BR300W400	1	200	200 Ω
	2	1.5	0.849	400W 300 Ω	BUE-40015	BR200W150	2	140	160 Ω
	3	2.2	1.262	*	*	*			
	5	3.7	2.080	*	*	*			

NOTE: "*" under development

 **NOTE**

1. If damage to the drive or other equipment is due to the fact that the brake resistors and the brake modules in use are not provided by Delta, the warranty will be void.
2. Take into consideration the safety of the environment when installing the brake resistors.
3. Definition for Brake Usage ED%

Explanation: The definition of the braking usage ED(%) is for assurance of enough time for the brake unit and brake resistor to dissipate away heat generated by braking. When the brake resistor heats up, the resistance would increase with temperature, and brake torque would decrease accordingly. Suggested cycle time is one minute

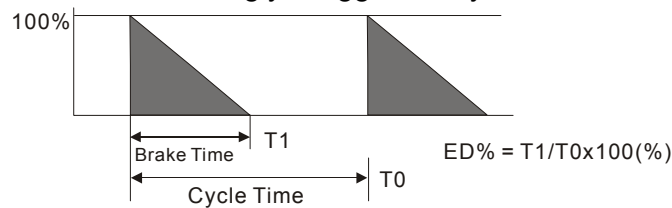

4. Please select the brake unit and/or brake resistor according to the table. “-“ means no Delta product. Please use the brake unit according to the Equivalent Resistor Value.
5. For safety reasons, install a thermal overload relay between brake unit and brake resistor. Together with the magnetic contactor (MC) in the mains supply circuit to the drive it offers protection in case of any malfunctioning. The purpose of installing the thermal overload relay is to protect the brake resistor against damage due to frequent brake or in case the brake unit is continuously on due to unusual high input voltage. Under these circumstances the thermal overload relay switches off the power to the drive. Never let the thermal overload relay switch off only the brake resistor as this will cause serious damage to the brushless DC motor drive.

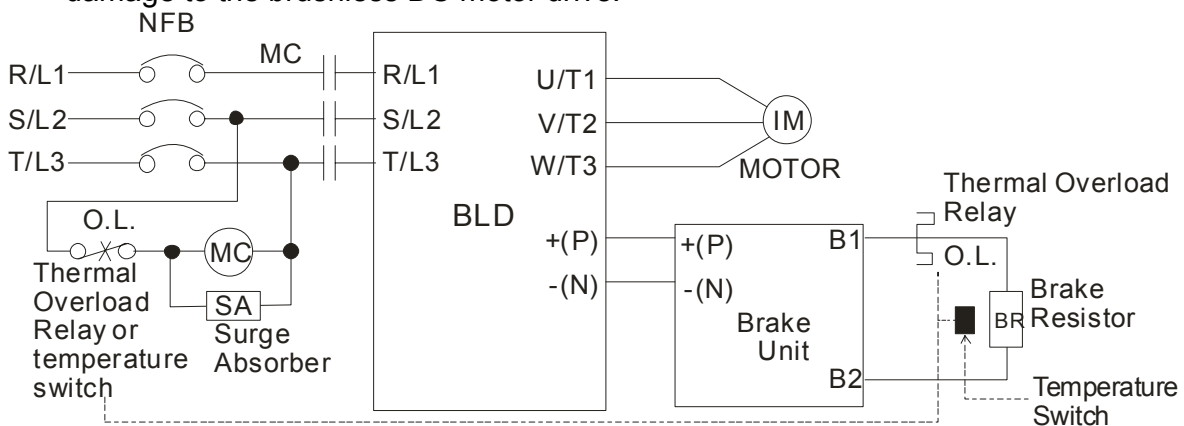

Note 1: When using the drive with DC reactor, please refer to wiring diagram in the drive user manual for the wiring of terminal +(P) of Brake unit.

Note 2: **Do NOT** wire terminal -(N) to the neutral point of power system.

B.1.1 Dimensions and Weights for Brake Resistors

(Dimensions are in millimeter)

Order P/N: BR080W200, BR080W750, BR300W070, BR300W100, BR300W250, BR300W400, BR400W150, BR400W040

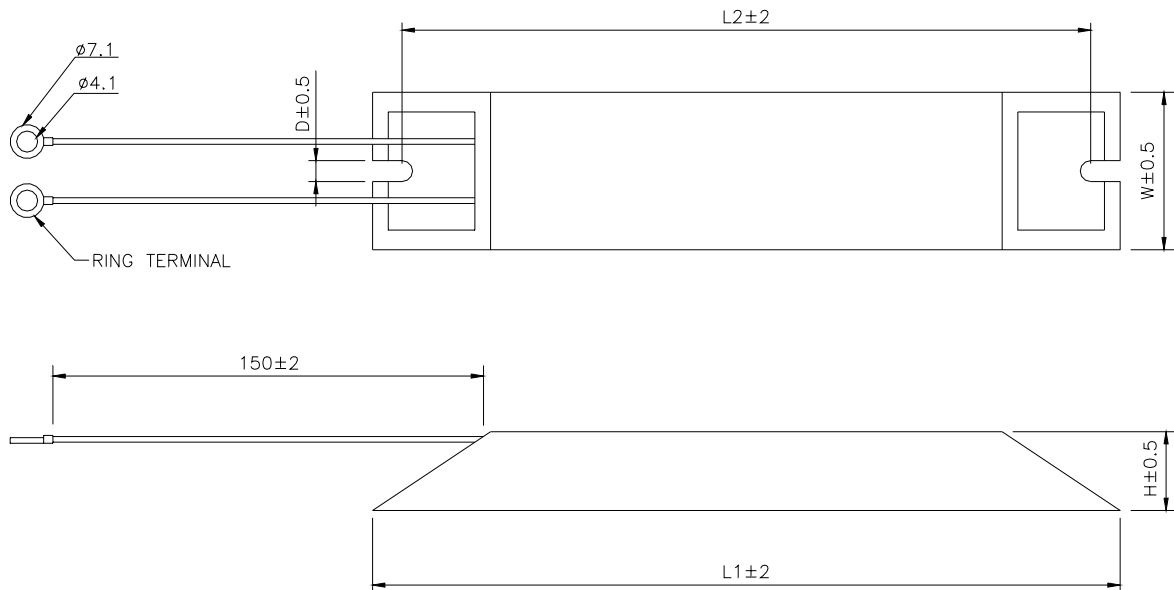

TYPE	L1	L2	H	D	W	MAX. WEIGHT(g)
BR080W200	140	125	20	5.3	60	160
BR080W750	140	125	20	5.3	60	160
BR300W070	215	200	30	5.3	60	750
BR300W100	215	200	30	5.3	60	750
BR300W250	215	200	30	5.3	60	750
BR300W400	215	200	30	5.3	60	750
BR400W150	265	250	30	5.3	60	930
BR400W040	265	250	30	5.3	60	930

Order P/N: BR500W030, BR500W100, BR1KW020, BR1KW075

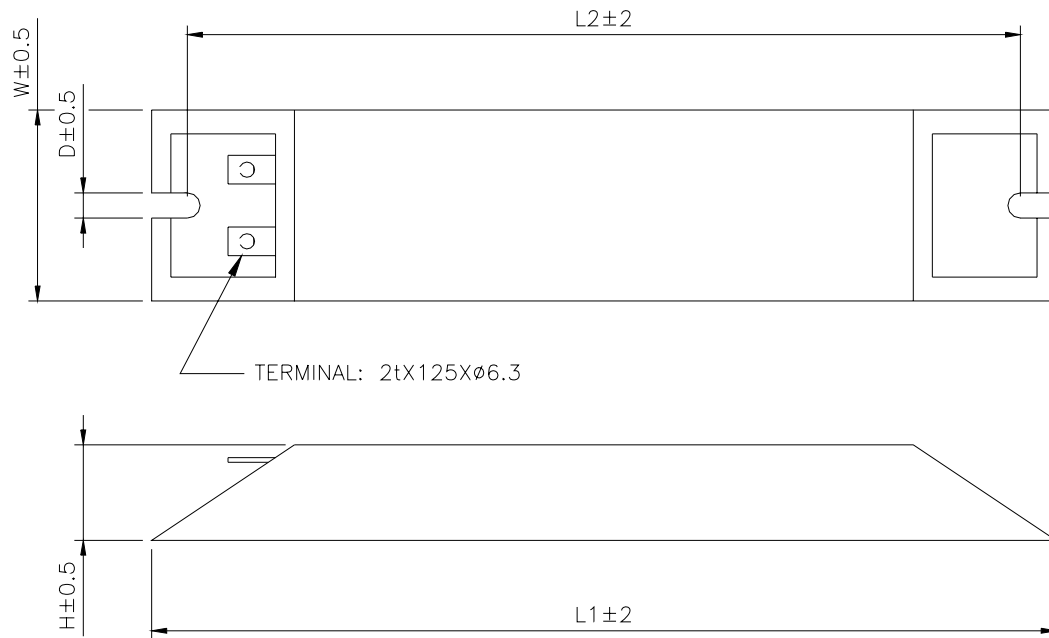

Model no.	L1	L2	H	D	W	Max. Weight (g)
BR500W030	335	320	30	5.3	60	1100
BR500W100						
BR1KW020	400	385	50	5.3	100	2800
BR1KW075						

Order P/N: BR1K0W050, BR1K2W008, BR1K2W6P8, BR1K5W005, BR1K5W040

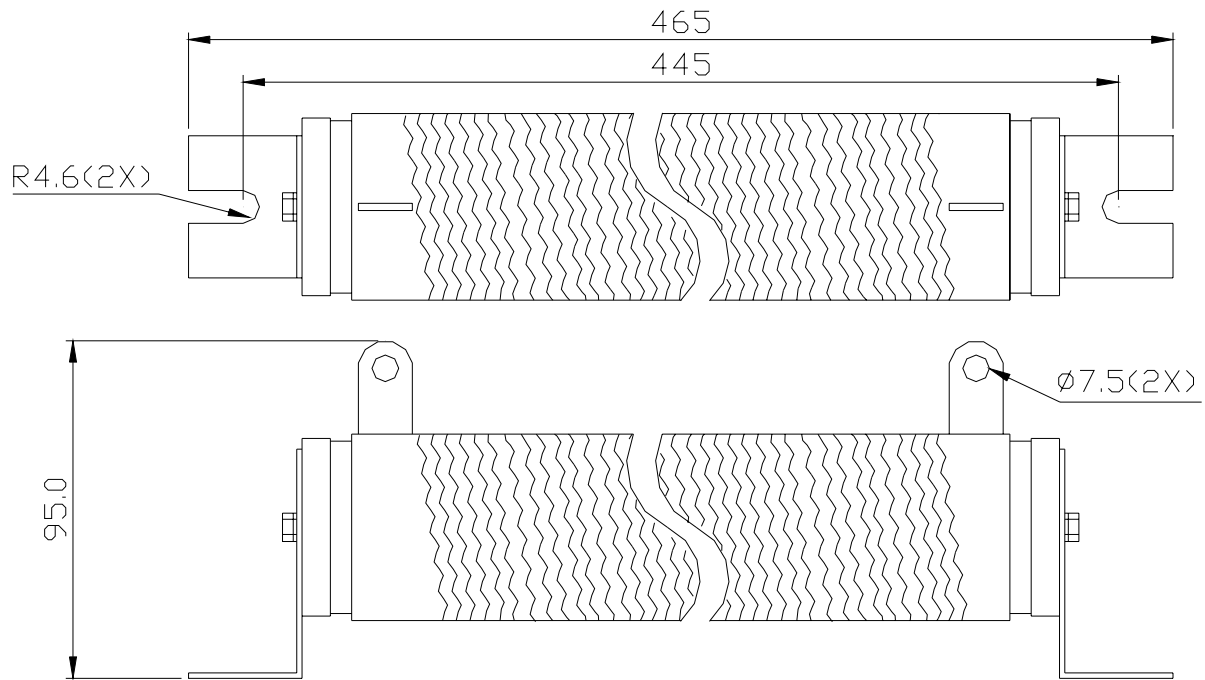

B.2 No-fuse Circuit Breaker Chart

For 1-phase/3-phase drives, the current rating of the breaker shall be within 2-4 times rated input current.

1-phase		3-phase	
Model	Recommended no-fuse breaker (A)	Model	Recommended no-fuse breaker (A)
BLD002E111A	15	BLD002E123A	5
BLD002E121A	10	BLD004E123A	5
BLD004E111A	20	BLD004E143A	5
BLD004E121A	15	BLD007E123A	10
BLD007E111A	30	BLD007E143A	5
BLD007E121A	20	BLD015E123A	20
BLD015E121A	30	BLD015E143A	10
BLD022E121A	50	BLD022E123A	30
		BLD022E143A	15
		BLD037E123A	40
		BLD037E143A	20

B.3 Fuse Specification Chart

Smaller fuses than those shown in the table are permitted.

Model	I (A) Input	I (A) Output	Line Fuse	
			I (A)	Bussmann P/N
BLD002E111A	6.4	1.6	15	JJN-15
BLD002E121A	4.9	1.6	10	JJN-10
BLD002E123A	1.9	1.6	5	JJN-6
BLD004E111A	9	2.5	20	JJN-20
BLD004E121A	6.5	2.5	15	JJN-15
BLD004E123A	2.7	2.5	5	JJN-6
BLD004E143A	1.8	1.5	5	JJS-6
BLD007E111A	18	4.2	30	JJN-30
BLD007E121A	9.3	4.2	20	JJN-20
BLD007E123A	4.9	4.2	10	JJN-10
BLD007E143A	3.2	2.5	5	JJS-6
BLD015E121A	15.7	7.5	30	JJN-30
BLD015E123A	9	7.5	20	JJN-20
BLD015E143A	4.3	4.2	10	JJS-10
BLD022E121A	24	11	50	JJN-50
BLD022E123A	15	11	30	JJN-30
BLD022E143A	7.1	5.5	15	JJS-15
BLD037E123A	20.6	17	40	JJN-40
BLD037E143A	9.0	8.2	20	JJS-20

B.4 AC Reactor

B.4.1 AC Input Reactor Recommended Value

230V, 50/60Hz, 1-Phase

kW	HP	Fundamental Amps	Max. continuous Amps	Inductance (mH)	
				3~5% impedance	
0.2	0.25	4	6	6.5	
0.4	0.5	5	7.5	3	
0.75	1	8	12	1.5	
1.5	2	12	18	1.25	
2.2	3	18	27	0.8	

460V, 50/60Hz, 3-Phase

kW	HP	Fundamental Amps	Max. continuous Amps	Inductance (mH)	
				3% impedance	5% impedance
0.4	0.5	2	3	20	32
0.75	1	4	6	9	12
1.5	2	4	6	6.5	9
2.2	3	8	12	5	7.5
3.7	5	8	12	3	5

B.4.2 AC Output Reactor Recommended Value

115V/230V, 50/60Hz, 3-Phase

kW	HP	Fundamental Amps	Max. continuous Amps	Inductance (mH)	
				3% impedance	5% impedance
0.2	0.25	4	6	9	12
0.4	0.5	4	6	6.5	9
0.75	1	8	12	3	5
1.5	2	8	12	1.5	3

kW	HP	Fundamental Amps	Max. continuous Amps	Inductance (mH)	
				3% impedance	5% impedance
2.2	3	12	18	1.25	2.5
3.7	5	18	27	0.8	1.5

460V, 50/60Hz, 3-Phase

kW	HP	Fundamental Amps	Max. continuous Amps	Inductance (mH)	
				3% impedance	5% impedance
0.4	0.5	2	3	20	32
0.75	1	4	6	9	12
1.5	2	4	6	6.5	9
2.2	3	8	12	5	7.5
3.7	5	12	18	2.5	4.2

B.4.3 Applications

Connected in input circuit

Application 1	Question
When more than one brushless DC motor drive is connected to the same mains power, and one of them is ON during operation.	When applying power to one of the brushless DC motor drive, the charge current of the capacitors may cause voltage dip. The brushless DC motor drive may be damaged when over current occurs during operation.

Correct wiring

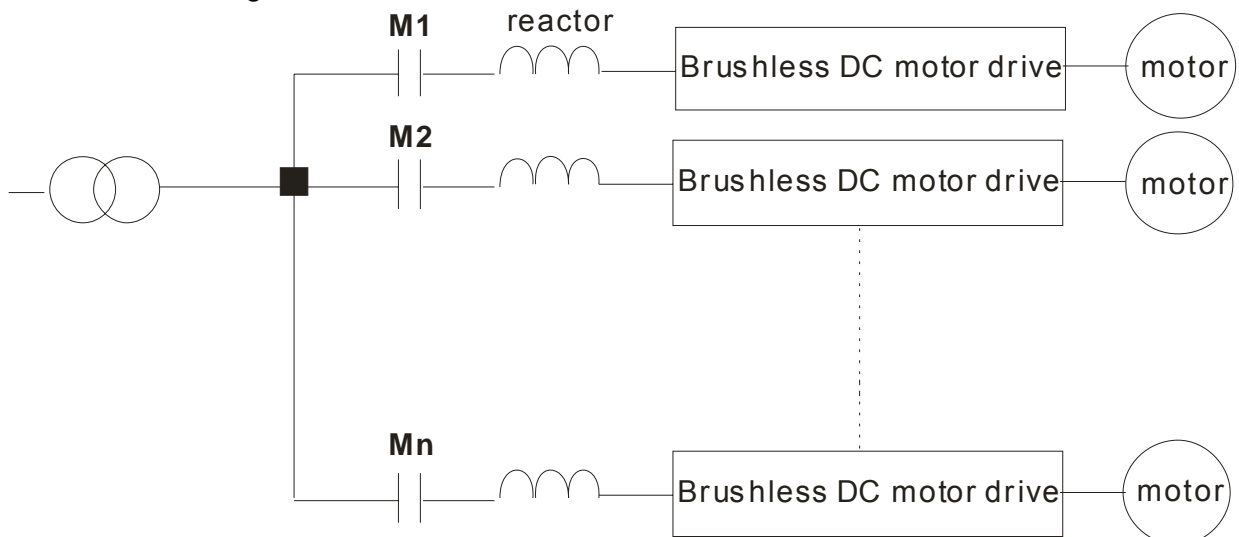

Application 2	Question
Silicon rectifier and brushless DC motor drive are connected to the same power.	Switching spikes will be generated when the silicon rectifier switches on/off. These spikes may damage the mains circuit.

Correct wiring

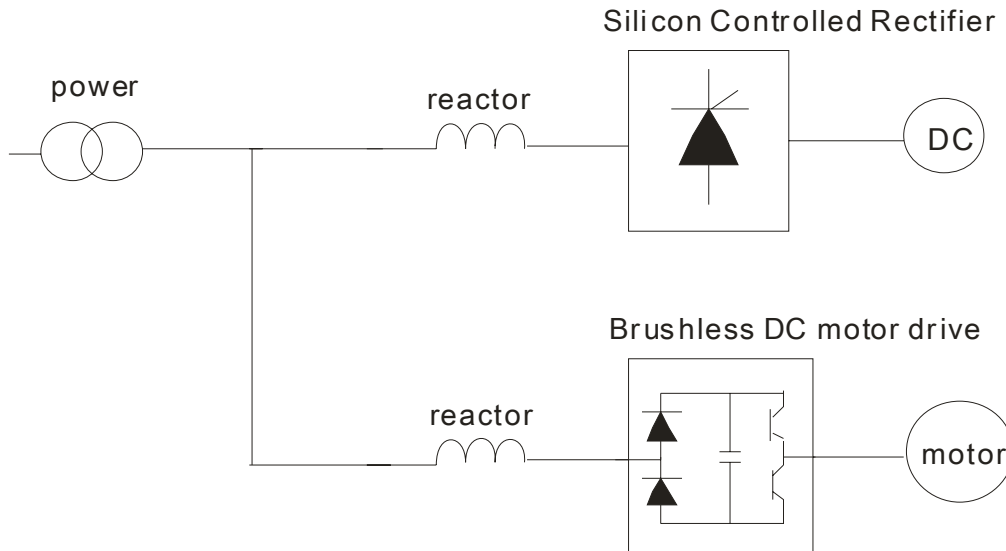

Application 3	Question
For the applications that power capacity is more than 10 times of power capacity of brushless DC motor drive.	When the mains power capacity is too large, line impedance will be small and the charge current will be too high. This may damage brushless DC motor drive due to higher rectifier temperature.

Correct wiring

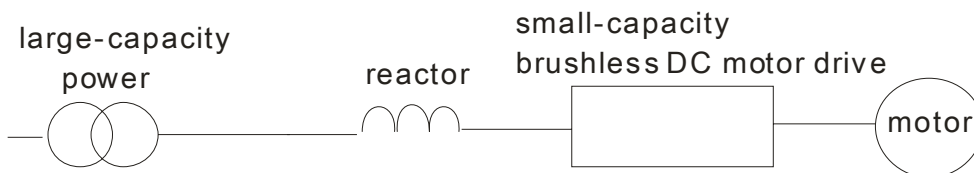

B.5 Zero Phase Reactor (RF220X00A)

Dimensions are in millimeter and (inch)

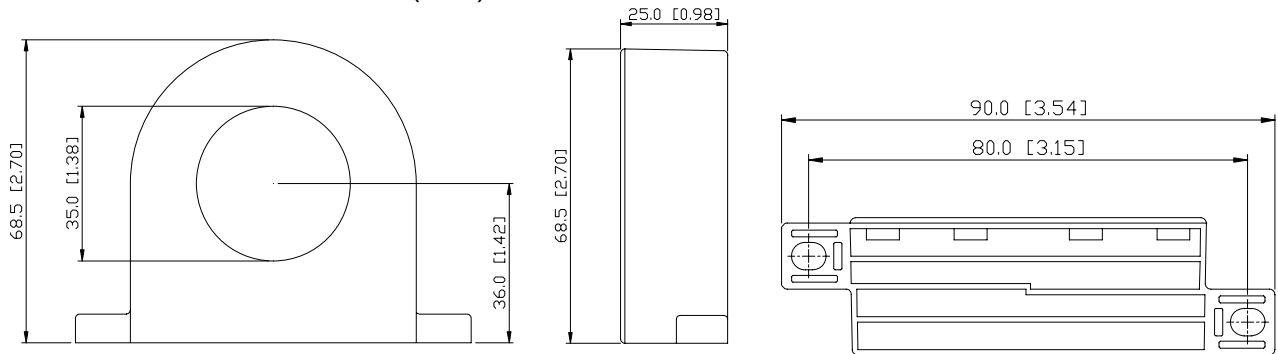

Cable type (Note)	Recommended Wire Size (mm ²)			Qty.	Wiring Method
	AWG	mm ²	Nominal (mm ²)		
Single-core	≤10	≤5.3	≤5.5	1	Diagram A
	≤2	≤33.6	≤38	4	Diagram B
Three-core	≤12	≤3.3	≤3.5	1	Diagram A
	≤1	≤42.4	≤50	4	Diagram B

Note: 600V Insulated unshielded Cable

Note 1: The table above gives approximate wire size for the zero phase reactors but the selection is ultimately governed by the type and diameter of cable fitted i.e. the cable must fit through the center hole of zero phase reactors.

Note 2: Only the phase conductors should pass through, not the earth core or screen.

Note 3: When long motor output cables are used an output zero phase reactor may be required to reduce radiated emissions from the cable

Diagram A

Please wind each wire 4 times around the core. The reactor must be put at inverter output as close as possible.

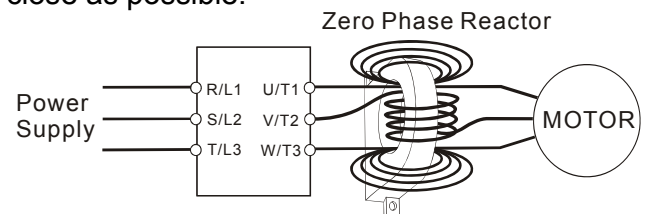
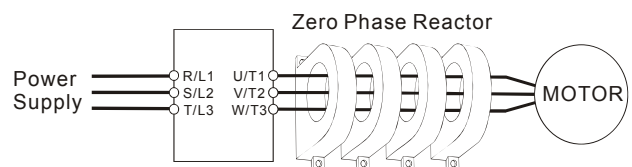

Diagram B

Please put all wires through 4 cores in series without winding.



B.6 DIN Rail

Dimensions

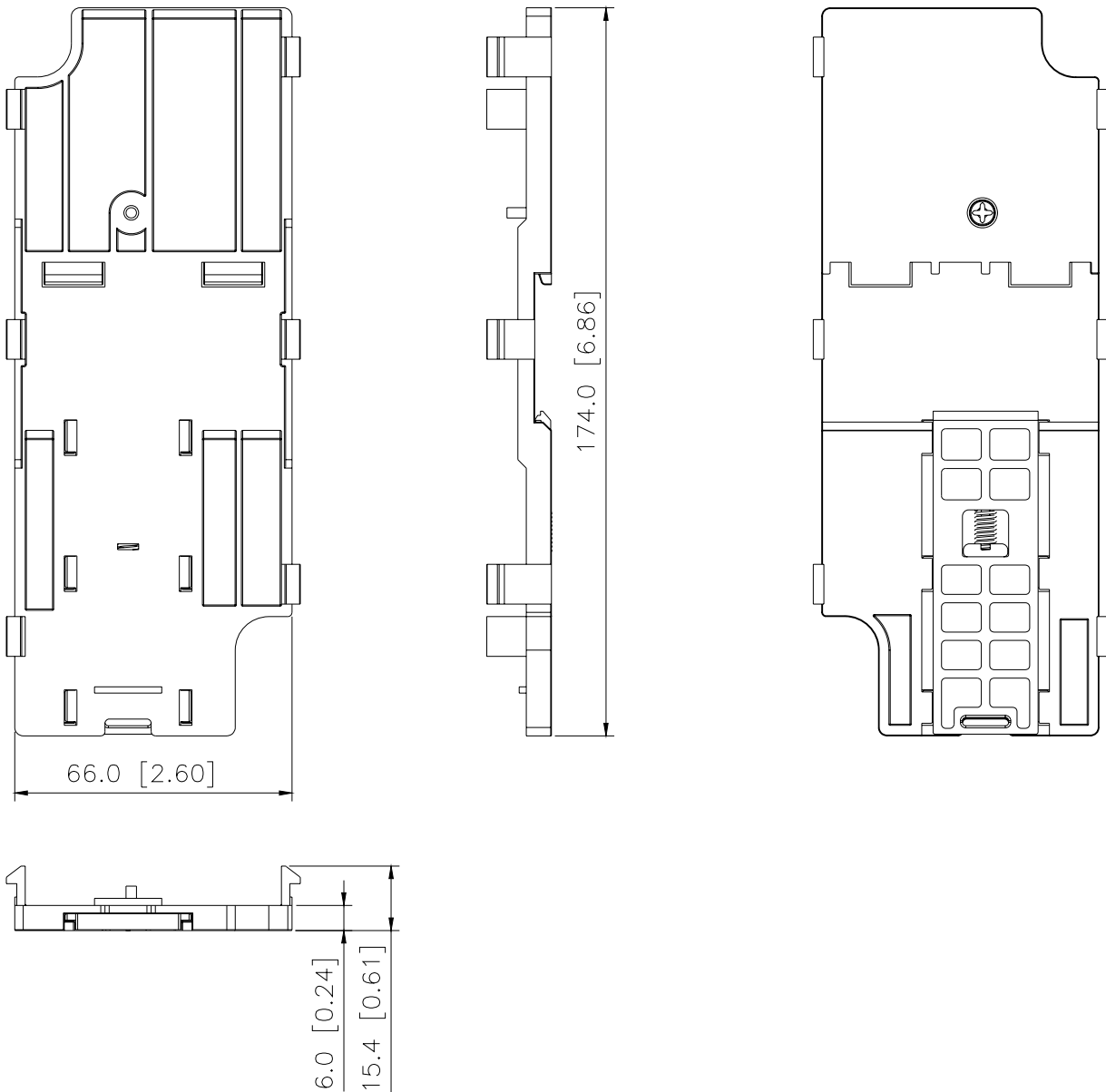

This is only applicable for frame A. As for frame B, it is a standard accessory and please refer to chapter 1 for dimensions.



Frame A: BLD002E111A/121A/123A, BLD004E111A/121A/123A/143A, BLD007E121A/123A/143A, BLD015E123A/143A

Frame B: BLD007E111A , BLD015E121A, BLD022E121A, BLD022E121A /123A/143A, BLD037E123A/143A



DELTA ELECTRONICS, INC.

www.delta.com.tw/industrialautomation

IABU Headquarters

Delta Electronics, Inc.

Taoyuan1

31-1, Xingbang Road, Guishan Industrial Zone,
Taoyuan County 33370, Taiwan, R.O.C.
TEL: 886-3-362-6301 / FAX: 886-3-362-7267

Asia

Delta Electronics (Jiang Su) Ltd.

Wujiang Plant3

1688 Jiangxing East Road,
Wujiang Economy Development Zone,
Wujiang City, Jiang Su Province,
People's Republic of China (Post code: 215200)
TEL: 86-512-6340-3008 / FAX: 86-512-6340-7290

Delta Greentech (China) Co., Ltd.

238 Min-Xia Road, Cao-Lu Industry Zone, Pudong, Shanghai,
People's Republic of China
Post code : 201209
TEL: 021-58635678 / FAX: 021-58630003

Delta Electronics (Japan), Inc.

Tokyo Office

Delta Shibadaimon Building, 2-1-14
Shibadaimon, Minato-Ku, Tokyo, 105-0012,
Japan
TEL: 81-3-5733-1111 / FAX: 81-3-5733-1211

Delta Electronics (Korea), Inc.

234-9, Duck Soo Building 7F, Nonhyun-Dong,
Kangnam-Gu, Seoul, Korea 135-010
TEL: 82-2-515-5305 / FAX: 82-2-515-5302

Delta Electronics (Singapore) Pte. Ltd.

8 Kaki Bukit Road 2, #04-18 Ruby Warehouse Complex,
Singapore 417841
TEL: 65-6747-5155 / FAX: 65-6744-9228

Delta Power Solutions (India) Pte. Ltd.

Plot No. 28, Sector-34, EHTP
Gurgaon-122001 Haryana, India
TEL: 91-124-416-9040 / FAX: 91-124-403-6045

America

Delta Products Corporation (USA)

Raleigh Office

P.O. Box 12173, 5101 Davis Drive,
Research Triangle Park, NC 27709, U.S.A.
TEL: 1-919-767-3813 / FAX: 1-919-767-3969

Delta Greentech (Brasil) S/A

Sao Paulo Office

Rua Itapeva, N° 26, 3° andar, Bela vista
ZIP: 01332-000 - São Paulo - SP - Brasil
TEL : 55-11-3568-3875 / FAX : 55-11-3568-3865

Europe

Deltronics (The Netherlands) B.V.

Eindhoven Office

De Witbogt 15, 5652 AG Eindhoven, The Netherlands
TEL: 31-40-2592850 / FAX: 31-40-2592851

5011689100
201004-23



00DE

*We reserve the right to change the information in this catalogue without prior notice

Free Manuals Download Website

<http://myh66.com>

<http://usermanuals.us>

<http://www.somanuals.com>

<http://www.4manuals.cc>

<http://www.manual-lib.com>

<http://www.404manual.com>

<http://www.luxmanual.com>

<http://aubethermostatmanual.com>

Golf course search by state

<http://golfingnear.com>

Email search by domain

<http://emailbydomain.com>

Auto manuals search

<http://auto.somanuals.com>

TV manuals search

<http://tv.somanuals.com>