

Demco manufacturing
Dethmers Manufacturing Company

DOING OUR BEST TO PROVIDE YOU THE BEST

DA66B

BRAKE ACTUATOR

OPERATORS MANUAL

ASSEMBLY
CALIBRATION
OPERATION
REPLACEMENT PARTS

READ complete manual CAREFULLY
BEFORE attempting operation.

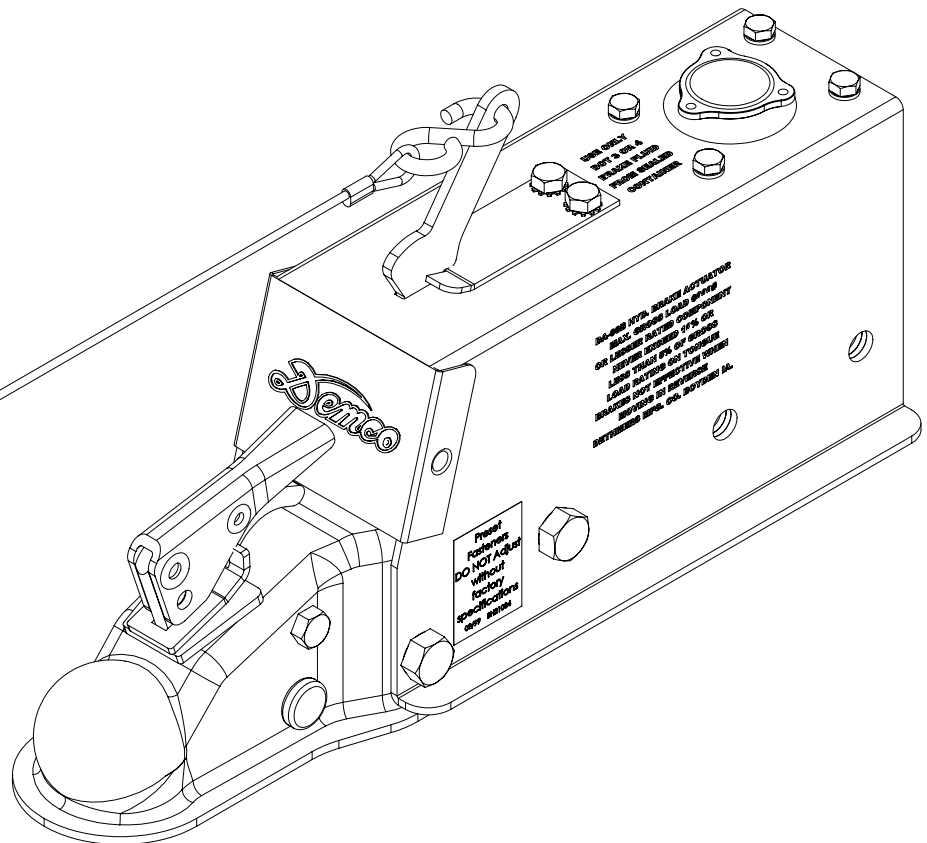

DEMCO • Dethmers Mfg. Co. • 4010 320th St. • P.O. Box 189 • Boyden, IA 51234
PH: (712) 725-2311 • Toll Free: 1-800-543-3626 • FAX: 1-800-845-6420
www.demco-products.com

DEMCO MODEL DA66B ACTUATOR

Model DA66B is a hydraulic surge brake actuator for trailers with two or four wheels. When brakes are applied on the towing vehicle, forward inertia of trailer toward towing vehicle applies brakes on trailer in direct relation to manner brakes are applied on towing vehicle. Brake towing vehicle hard and brakes on trailer are applied hard. Master cylinder push rod spring assembly protects system from hydraulic pressure overload.



WARNING: To Prevent Serious Injury or Death

- Review following instructions before installation and use of hydraulic brake actuator.
- Dealers or distributors must review these instructions with ultimate user.
- Failure to follow these instructions, or failure to properly maintain braking system after installation, can result in loss of braking action.

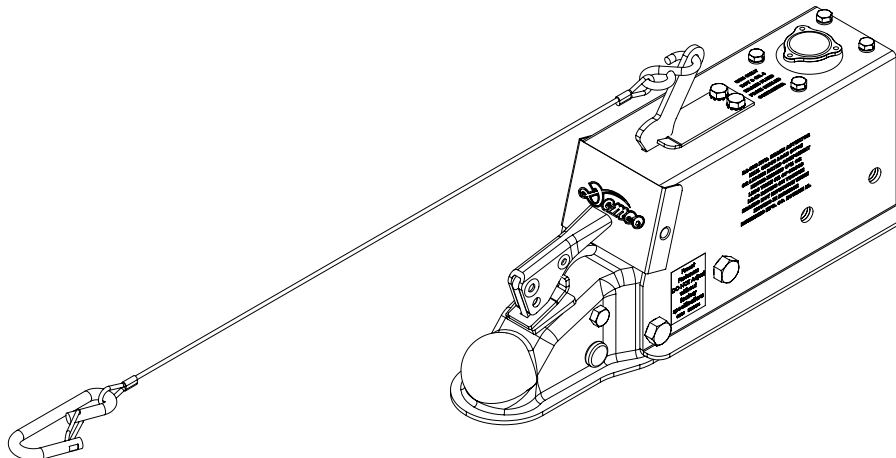

Table of Contents

General information	2
Warranty Registration	3-4
Safety, Signal Words	5
Equipment Safety Guidelines	6
Safety Sign Locations	7
Safety Sign Care	8
Remember	8
Before Operation	9
During Operation	9-10
Following Operation	11
Highway and Transport Operations	11-12
Performing Maintenance	12
Bolt Torque	13
DA66B Brake Actuator Parts Breakdown and Parts List	14-15
Actuator Installation and Maintenance	16-17
Demco Brake Products Limited Warranty	18
Demco Brake Products Limited Warranty Cont.	19



Warranty Registration

Dethmers Manufacturing Company
4010 320th Street • Box 189 • Boyden, Iowa 51234
Toll Free 800-54DEMCO (800-543-3626) • FAX 800-845-6420
www.demco-products.com

Ag	<input type="radio"/>
RV	<input type="radio"/>
Rental	<input type="radio"/>
Brakes	<input type="radio"/>
Marine	<input type="radio"/>

	Very Satisfied	Satisfied	Dissatisfied	Very Dissatisfied
How satisfied are you with our product?	<input type="radio"/>	<input type="radio"/>	<input type="radio"/>	<input type="radio"/>
How satisfied are you with the dealership/distributor sales staff?	<input type="radio"/>	<input type="radio"/>	<input type="radio"/>	<input type="radio"/>
Dealer/Distributor Name _____ City _____ State _____				
How satisfied are you with the company sales staff?	<input type="radio"/>	<input type="radio"/>	<input type="radio"/>	<input type="radio"/>
How satisfied are you with the delivery?	<input type="radio"/>	<input type="radio"/>	<input type="radio"/>	<input type="radio"/>
Did you have any contact with a Demco Representative?	YES	NO		
If YES, how satisfied were you?	<input type="radio"/>	<input type="radio"/>	<input type="radio"/>	<input type="radio"/>
I would recommend this product to my family and friends.	YES	NO		
Would you purchase again from DEMCO?	YES	NO		
Since taking delivery, have you been contacted by the dealer?	YES	NO		
Did you have any problems with this DEMCO product?	YES	NO		
If YES, are you satisfied with the company's resolution of your problem?	<input type="radio"/>	<input type="radio"/>	<input type="radio"/>	<input type="radio"/>

Why did you purchase this product? _____

Please list the specific source of information prompting this purchase.

After purchasing this product, do you see any needed product improvement? _____ If yes, what improvement? _____

What other products would you like to see DEMCO offer? _____

Comments _____

Owner's Name: _____ Mailing Address: _____

City: _____ State: _____ Zip Code: _____

Model#: _____

Serial #: _____

Purchase Date: _____

Owner's Signature: _____

Please return to DETHMERS MFG. CO. By FAX or tri-folding this form to the backside, it is pre-addressed.

Postage

*Dethmers Manufacturing Company
4010 320th Street, Box 189
Boyden, Iowa 51234*

SAFETY

TAKE NOTE! THIS SAFETY ALERT SYMBOL FOUND THROUGHOUT THIS MANUAL IS USED TO CALL YOUR ATTENTION TO INSTRUCTIONS INVOLVING YOUR PERSONAL SAFETY AND SAFETY OF OTHERS. FAILURE TO FOLLOW THESE INSTRUCTIONS CAN RESULT IN INJURY OR DEATH.



THIS SYMBOL MEANS

ATTENTION

BECOME ALERT

YOUR SAFETY IS INVOLVED!

SIGNAL WORDS

Note use following signal words **DANGER**, **WARNING**, and **CAUTION** with safety messages. Appropriate signal word for each has been selected using following guidelines:

DANGER:

Indicates an imminently hazardous situation that, if not avoided, will result in death or serious injury. This signal word is to be limited to most extreme situations typically for machine components which, for functional purposes, cannot be guarded.

WARNING:

Indicates a potentially hazardous situation that, if not avoided, could result in death or serious injury, and includes hazards that are exposed when guards are removed. It may also be used to alert against unsafe practices.

CAUTION:

Indicates a potentially hazardous situation that, if not avoided, may result in minor or moderate injury. It may also be used to alert against unsafe practices.

If you have questions not answered in this manual, require additional copies, or if your manual is damaged, please contact your dealer or Dethmers Mfg. Co., P.O. Box 189, 4010 320th Street, Boyden, IA 51234
ph: (712) 725-2311 or (712) 725-2302 Toll Free: 1-800-543-3626 Fax: (712) 725-2380

<http://www.demco-products.com>



SAFETY...YOU CAN LIVE WITH IT



EQUIPMENT SAFETY GUIDELINES

Every year many accidents occur which could have been avoided by a few seconds of thought and a more careful approach to handling equipment. You the operator, can avoid many accidents by observing and following precautions in this section. To avoid personal injury, study the following precautions and insist those working with you, or you yourself, follow them.

In order to provide a better view, certain illustrations in this manual may show an assembly with a safety shield removed. However, equipment should never be operated in this condition. Keep all shields in place. If shield removal becomes necessary for repairs, replace shield prior to use.

Replace any caution, warning, danger or instruction safety decal that is not readable or is missing. Location of such decals is indicated in this booklet.

Do not attempt to operate this equipment under the influence of alcohol or drugs.

Review safety instructions with all users.

Operator should be a responsible adult. **DO NOT ALLOW PERSONS TO OPERATE OR ASSEMBLE THIS UNIT UNTIL THEY HAVE DEVELOPED A THOROUGH UNDERSTANDING OF SAFETY PRECAUTIONS AND HOW IT WORKS.**

Do not paint over, remove, or deface any safety signs or warning decals on your equipment. Observe all safety signs and practice instructions on them.

Never exceed limits of a piece of machinery. If its ability to do a job, or to do so safely is in question-**DON'T TRY IT.**



SAFETY SIGN LOCATIONS

Types of safety sign and locations on equipment are shown in illustration below. Good safety requires that you familiarize yourself with various safety signs, type of warning, and area or particular function related to that area, that requires your SAFETY AWARENESS.

DRUM BRAKES

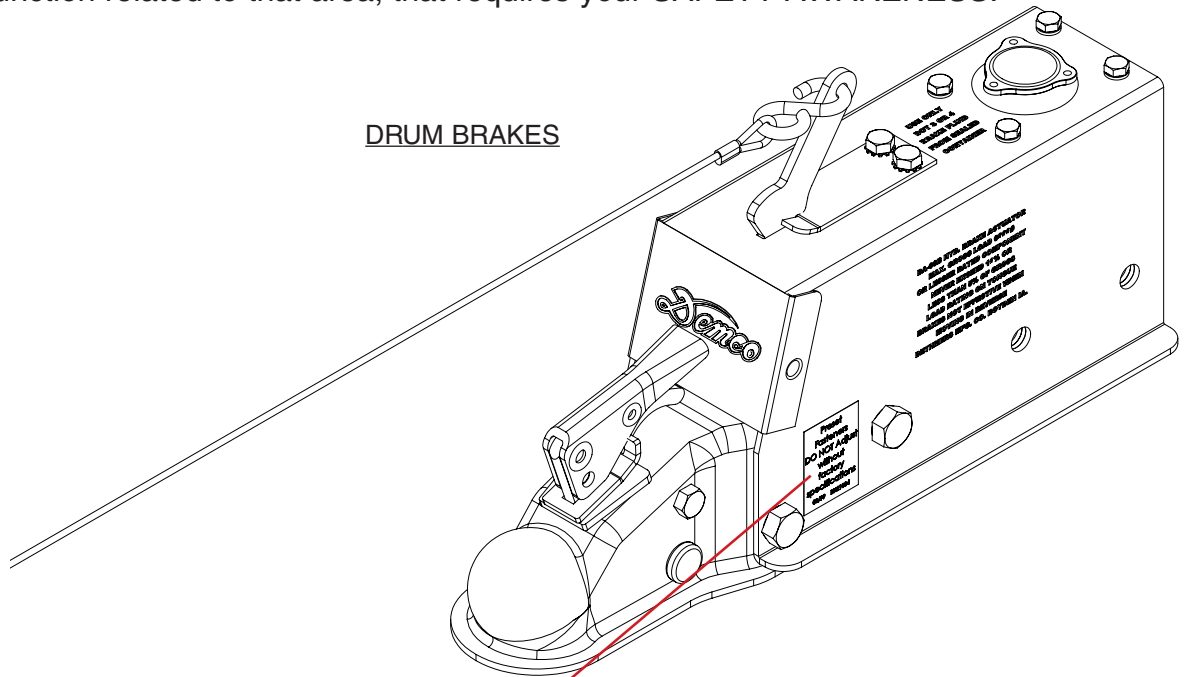

This decal is located in the position shown on both sides of the actuator. The replacement part number for two decals is BH21004.

Preset Fasteners DO NOT adjust without factory specifications.

DISC BRAKES

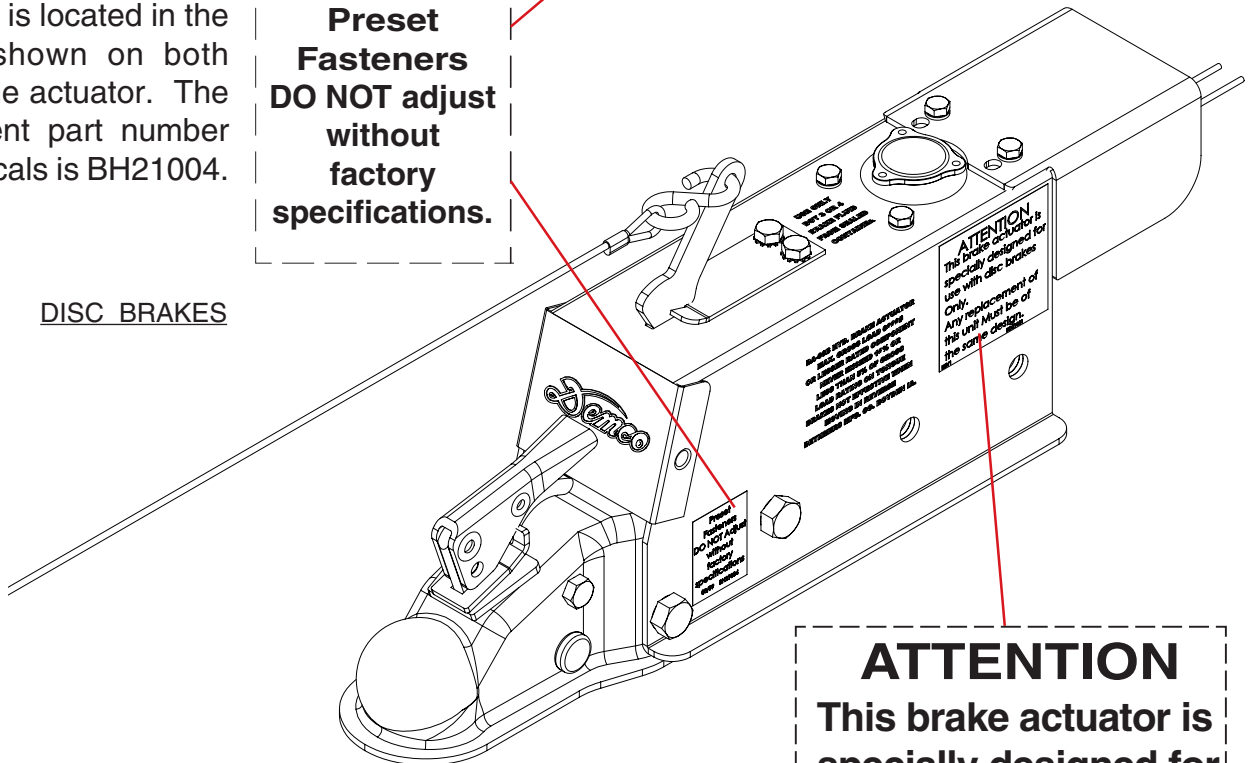

This decal is located in the position shown on both sides of the actuator. The replacement part number for one decal is BD21001.

ATTENTION
This brake actuator is specially designed for use with disc brakes ONLY.
Any replacement of this unit MUST be of the same design.

REV 1

BD21001



SAFETY SIGN CARE

- Keep safety signs clean and legible at all times.
- Replace safety signs that are missing or have become illegible.
- Replacement parts that displayed a safety sign should also display safety sign.
- Safety signs are available from your distributor, dealer parts department, or factory.

How to install safety signs:

- Be sure that installation area is clean and dry.
- Decide on exact position before you remove backing paper.
- Remove smallest portion of split backing paper.
- Align decal over specified area and carefully press small portion with exposed sticky backing in place.
- Slowly peel back remaining paper and carefully smooth remaining portion of decal into place.
- Small air pockets can be pierced with a pin and smoothed out using piece of decal backing paper.



REMEMBER

Your best assurance against accidents is a careful and responsible operator. If there is any portion of this manual or function you do not understand, contact your local authorized dealer or manufacturer.



BEFORE OPERATION:

- Carefully review and follow the installation instructions on page 16 of this manual.
- Carefully study and understand this manual.
- Always wear protective clothing and substantial shoes.
- Give equipment a visual inspection for any loose bolts, worn parts, or cracked welds, and make necessary repairs. Follow maintenance safety instructions included in this manual.
- Be sure there are no tools lying on or in equipment.
- Do not use equipment until you are sure that area is clear, especially around children and animals.
- Don't hurry learning process or take equipment for granted. Ease into it and become familiar with your new equipment.
- Practice operation of your equipment and its attachments. Completely familiarize yourself and other operators with its operation before using.
- Make sure that brakes are evenly adjusted.
- Make sure tow rating on vehicle is high enough for what it is towing. Refer to your towing vehicle Owners Manual.
- Do not allow anyone to stand between tongue or hitch and towing vehicle when backing up to equipment.
- Securely attach to towing vehicle. Use appropriately sized hitch ball and/or hitch pin with a mechanical retainer and attach safety chains.
- Criss cross chains under tongue and secure to draw bar cage, mounting loops, or bumper frame.



DURING OPERATION

- **SAFETY CHAINS** If equipment is going to be transported on a public highway, safety chains should be obtained and installed. Always follow state and local regulations regarding safety chains and auxiliary lighting when towing equipment on a public highway. Be sure to check with local law enforcement agencies for your own particular regulations. Only safety chains (not an elastic or nylon/plastic tow straps) should be used to retain connection between towing and towed equipment in event of separation of primary attaching system.
- Install safety chains by criss crossing chains under tongue and secure to draw bar cage, mounting loops, or bumper frame.

- Beware of bystanders, **PARTICULARLY CHILDREN!** Always look around to make sure it is safe to start engine of towing vehicle or move equipment. This is particularly important with higher noise levels, as you may not hear people shouting.
- **NO PASSENGERS ALLOWED-** Do not carry passengers anywhere on or in equipment.
- Do not clean, lubricate, or adjust your equipment while it is moving.
- When halting operation, even periodically, set towing vehicles parking brake, shut off engine, and **remove the ignition key.**
- Be extra careful when using on inclines.
- **OPERATE TOWING UNIT CAUTIOUSLY. REDUCE SPEED TO ALLOW FOR ADDITIONAL WEIGHT OF TOWED UNIT.**
- Avoid loose gravel, rocks, and holes, they can be dangerous for equipment operation or movement.
- Allow for overall length when making turns.
- Keep all bystanders and pets clear of work area.
- Operate towing vehicle from operators seat only.
- Never leave running equipment attachments unattended.
- As a precaution, always recheck hardware on equipment following every 100 hours or 50 miles. Correct all problems. Follow maintenance safety procedures.



FOLLOWING OPERATION

- Following operation, or when unhitching, stop towing vehicle, set brakes, shut off the engine and **remove ignition key**.
- Store unit in an area away from human activity.
- Do not permit children to play on or around stored unit.
- Make sure all parked units are on a hard, level surface and engage all safety devices.
- Wheel chocks may be needed to prevent unit from rolling.



HIGHWAY AND TRANSPORT OPERATIONS

- Adopt safe driving practices:
 - Always drive at a safe speed relative to local conditions and ensure that your speed is low enough for an emergency stop.
 - Reduce speed prior to turns to avoid risk of overturning.
 - Always keep towing vehicle in gear to provide engine braking when going downhill. Do not coast.
 - Do not drink and drive!
- Comply with state and local laws governing highway safety on public roads.
- Use approved accessory lighting, flags and necessary warning devices to protect operators of other vehicles on highway during transport. Various safety lights and devices are available from your dealer.
- Local laws should be checked for all highway lighting and marking requirements.
- Plan your route to avoid heavy traffic.
- Be a safe and courteous driver. Always yield to oncoming traffic in all situations, including narrow bridges, intersections, etc.
- Be observant of bridge loading ratings. Do not cross bridges rated lower than the gross weight at which you are operating.

- Watch for obstructions overhead and side to side while transporting.
- Always operate equipment in a position to provide maximum visibility at all times. Make allowances for increased length and weight of equipment when making turns and/or stopping.



PERFORMING MAINTENANCE

- Carefully review and follow the maintenance instructions on page 17 of this manual.
- Good maintenance is your responsibility. Poor maintenance is an invitation to trouble.
- Make sure there is plenty of ventilation. Never operate engine of towing vehicle in a closed building. Exhaust fumes may cause asphyxiation.
- Before working on this unit, stop towing vehicle, set parking brakes, shut off engine and **remove ignition key**.
- Be certain all moving parts and attachments have come to a complete stop before attempting to perform maintenance.
- Always use safety supports and block wheels. Never use a jack to support unit.
- Always use proper tools or equipment for job at hand.
- Use extreme caution when making adjustments.
- Follow torque chart in this manual when tightening bolts and nuts.
- Openings in skin and minor cuts are susceptible to infection from brake fluid.
Without immediate medical treatment, serious infection and reactions can occur.
- Replace **all shields** and **guards** after servicing and before moving.
- After servicing, be sure all tools, parts and service equipment are removed.
- Do not allow grease or oil to build up on the actuator.
- When replacing bolts, refer to owners manual.
- Refer to bolt torque chart for head identification marking.
- Where replacement parts are necessary for periodic maintenance and servicing, genuine factory replacement parts must be used to restore your equipment to original specifications. Manufacturer is not responsible for damages resulting from use of unapproved parts or accessories.
- If equipment has been altered in any way from original design, manufacturer does not accept any liability for injury or warranty.
- A fire extinguisher and first aid kit should be kept readily accessible while performing maintenance on this equipment

BOLT TORQUE

TORQUE DATA FOR STANDARD NUTS, BOLTS, AND CAPSCREWS.

Tighten all bolts to torques specified in chart unless otherwise noted. Check tightness of bolts periodically, using bolt chart as guide. Replace hardware with same grade bolt.

NOTE: Unless otherwise specified, high-strength Grade 5 hex bolts are used throughout assembly of equipment.



Torque Specifications

Bolt Torque for Standard bolts *

"A"	GRADE 2		GRADE 5		GRADE 8	
	lb-ft	(N.m)	lb-ft	(N.m)	lb-ft	(N.m)
1/4"	6	(8)	9	(12)	12	(16)
5/16"	10	(13)	18	(25)	25	(35)
3/8"	20	(27)	30	(40)	45	(60)
7/16"	30	(40)	50	(70)	80	(110)
1/2"	45	(60)	75	(100)	115	(155)
9/16"	70	(95)	115	(155)	165	(220)
5/8"	95	(130)	150	(200)	225	(300)
3/4"	165	(225)	290	(390)	400	(540)
7/8"	170	(230)	420	(570)	650	(880)
1"	225	(300)	630	(850)	970	(1310)

Bolt Torque for Metric bolts *

"A"	CLASS 8.8		CLASS 9.8		CLASS 10.9	
	lb-ft	(N.m)	lb-ft	(N.m)	lb-ft	(N.m)
6	9	(13)	10	(14)	13	(17)
7	15	(21)	18	(24)	21	(29)
8	23	(31)	25	(34)	31	(42)
10	45	(61)	50	(68)	61	(83)
12	78	(106)	88	(118)	106	(144)
14	125	(169)	140	(189)	170	(230)
16	194	(263)	216	(293)	263	(357)
18	268	(363)	--	--	364	(493)
20	378	(513)	--	--	515	(689)
22	516	(699)	--	--	702	(952)
24	654	(886)	--	--	890	(1206)

Torque figures indicated are valid for non-greased or non-oiled threads and heads unless otherwise specified. Therefore, do not grease or oil bolts or capscrews unless otherwise specified in this manual. When using locking elements, increase torque values by 5%.

* GRADE or CLASS value for bolts and capscrews are identified by their head markings.

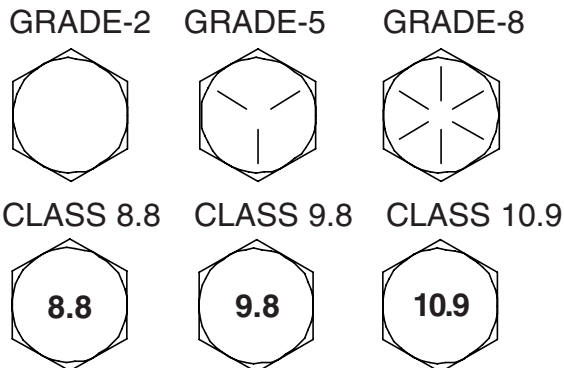
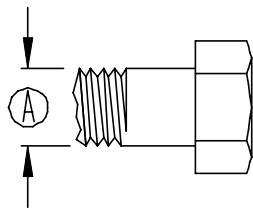

8605001 DRUM BRAKE ACTUATOR PARTS

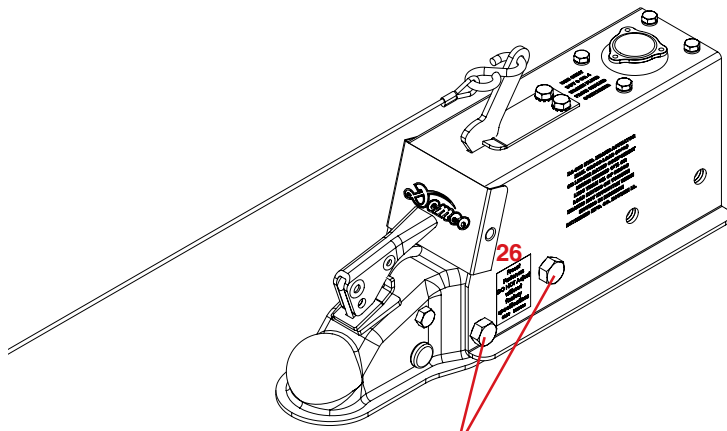

Do not tighten these bolts. They are factory torqued and must remain loose enough to allow free coupler movement.

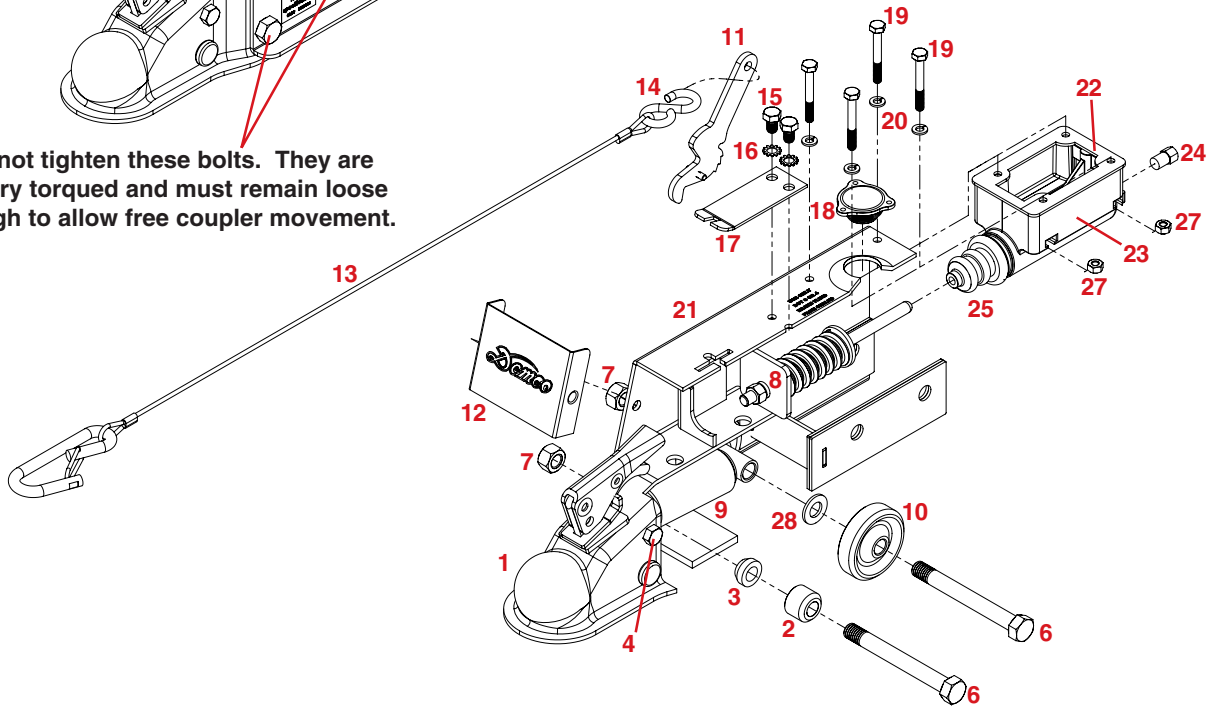

ACTUATOR PARTS LIST

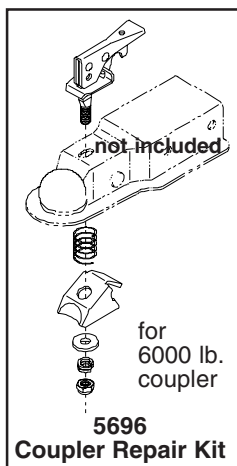
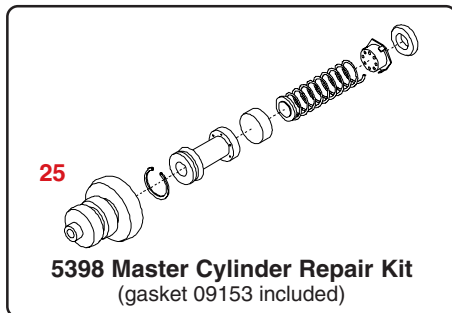

REF. NO.	PART NO.	QTY.	DESCRIPTION
1.	12190-95	1	6000# 2" Lever Lock Coupler
2.	SB23278	2	Roller
3.	12151	2	Front Roller Spacer
4.	02166	1	3/8"-16UNC X 2-3/7" Hex Head Bolt (gr.5)
5.	07176	1	3/8"-16UNC Stover Lock Nut
6.	05684	2	1/2"-13UNC x 4-7/16" Hex Head Bolt (gr.5)
7.	02178	2	1/2"-13UNC Nylon Insert Lock Nut
8.	12193	1	Push Rod Assembly
9.	05692	1	Damper/ Shock
10.	12103	2	Rear Roller Spacer
11.	*05951	1	Emergency Lever
12.	12201-95	1	Front Cover
13.	*12200	1	28" Cable with S-Hook & J-Hook
14.	SB10555	2	Replacement S-Hook ONLY
15.	05960	2	5/16"-18UNC x 1/2" Self-Tapping Screw
16.	05424	2	5/16" External Tooth Lock Washer
17.	*05693-95	1	Emergency Lever Spring
18.	03876	1	Master Cylinder Cap w/ Diaphragm & O-ring
19.	**00618	4	1/4"-20UNC x 2.00" Hex Head Bolt
20.	**00057	4	1/4" Spring Lock Washer
21.	12191-95	1	Outer Case
22.	**09153	1	Replacement Master Cyl. Gasket ONLY
23.	**10616	1	Master Cylinder (Not sold separately)
	5650	-	Master Cylinder Drum Kit (incl. items w/**)
24.	SB12098	1	Orifice
25.	05687	1	Master Cylinder Protective Boot
26.	BH21004	1	Safety Decal (See Page 6)
27.	**00062	4	1/4"-20UNC Nut
28.	02384	2	1/2" X 14 Gage Machine Washer
-	5400-	-	Emergency Lever Replacement Kit (incl. items w/**)
-	5398	-	Master Cylinder Repair Kit w/ gasket
-	5696	-	Coupler Repair Kit (lever lock)

Please order replacement parts by PART NO. and DESCRIPTION.

8605101 DISC BRAKE ACTUATOR PARTS

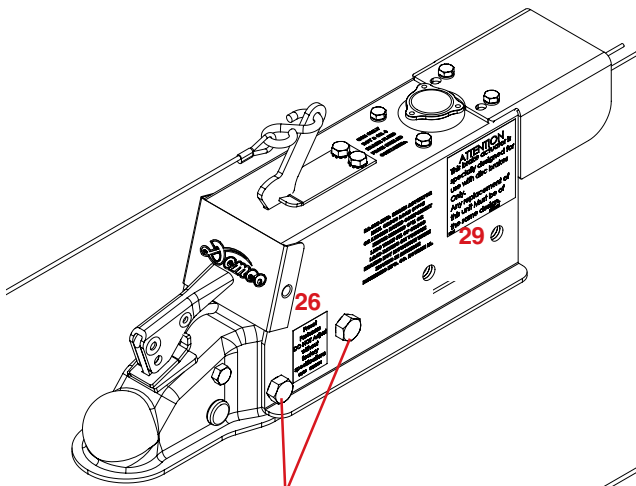

Do not tighten these bolts. They are factory torqued and must remain loose enough to allow free coupler movement.

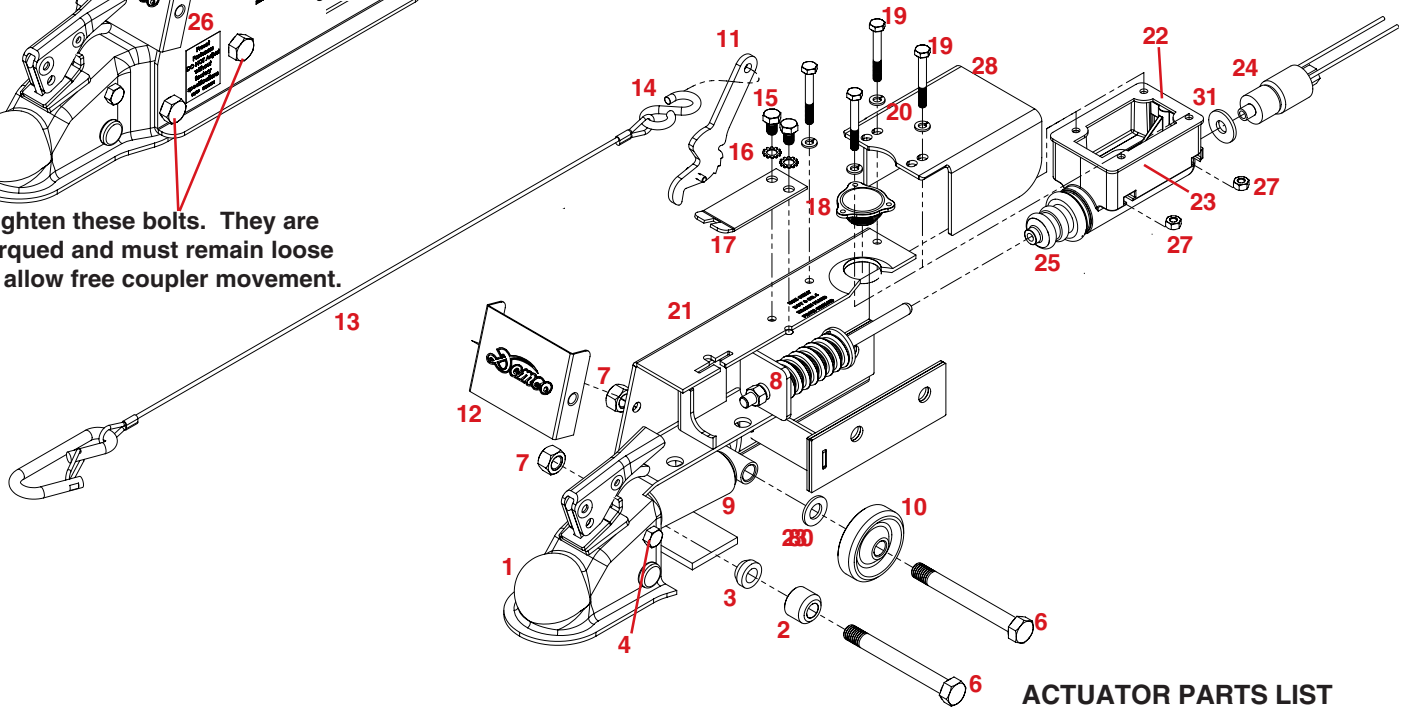

ACTUATOR PARTS LIST

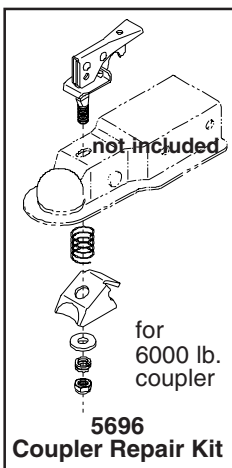
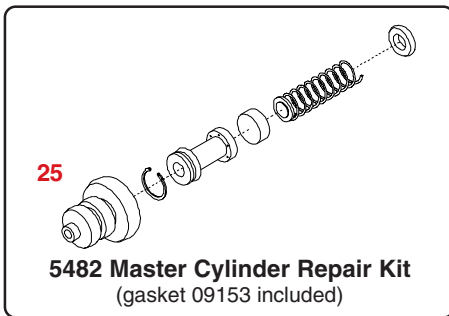

REF. NO.	PART NO.	QTY.	DESCRIPTION
1.	12190-95	1	6000# 2" Lever Lock Coupler
2.	SB23278	2	Roller
3.	12151	2	Front Roller Spacer
4.	02166	1	3/8"-16UNC X 2-3/7" Hex Head Bolt (gr.5)
5.	07176	1	3/8"-16UNC Stover Lock Nut
6.	05684	2	1/2"-13UNC x 4-7/16" Hex Head Bolt (gr.5)
7.	02178	2	1/2"-13UNC Nylon Insert Lock Nut
8.	12193	1	Push Rod Assembly
9.	05692	1	Damper/ Shock
10.	12103	2	Rear Roller Spacer
11.	*05951	1	Emergency Lever
12.	12201-95	1	Front Cover
13.	*12200	1	28" Cable with S-Hook & J-Hook
14.	SB10555	2	Replacement S-Hook ONLY
15.	05960	2	5/16"-18UNC x 1/2" Self-Tapping Screw
16.	05424	2	5/16" External Tooth Lock Washer
17.	*05693-95	1	Emergency Lever Spring
18.	03876	1	Master Cylinder Cap w/ Diaphragm & O-ring
19.	**00618	4	1/4"-20UNC x 2.00" Hex Head Bolt
20.	**00057	4	1/4" Spring Lock Washer
21.	12191-95	1	Outer Case
22.	**09153	1	Replacement Master Cyl. Gasket ONLY
23.	**11190	1	Master Cylinder (Not sold separately)
-	5672	-	Master Cylinder Disc Kit (incl. items w/**)
24.	11993	1	Inline Blocking Solenoid
25.	05687	1	Master Cylinder Protective Boot
26.	BH21004	1	Safety Decal (See Page 7)
27.	**00062	4	1/4"-20UNC Nut
28.	11674-95	1	Solenoid Cover
29.	BD21001	2	Disc Brakes Decal (See Page 7)
30.	02384	2	1/2" X 14 Gage Machine Washer
31.	07283	1	10mm Flat washer
-	5400-	-	Emergency Lever Replacement Kit (incl. items w/*)
-	5482	-	Master Cylinder Repair Kit w/ gasket
-	5696	-	Coupler Repair Kit (lever lock)

Please order replacement parts by PART NO. and DESCRIPTION.

DEMCO MODEL DA66B BRAKE ACTUATOR



WARNING To Prevent Serious Injury Or Death:

- Review all of the following instructions before installation and use of hydraulic brake actuator.
- Dealers or Distributors must review these instructions with ultimate user.
- Failure to follow these instructions, or failure to properly maintain braking system after installation, can result in loss of braking action which could cause severe property damage, personal injury or death.



WARNING

To avoid personal injury or death, do not exceed lowest of (1) the rated capacity of Model DA66B actuator, or (2) rated capacity of ball and hitch being used, or (3) trailer's Gross Vehicle Weight Rating (GVWR).

Model DA66B brake actuator has a maximum load rating of 6000 lbs. GVWR and 600 lbs. tongue load.



CAUTION

To avoid personal injury or death Do not weld on the outer case without disassembling actuator. The excessive heat may cause the actuator not to function properly

INSTALLATION

The Model DA66B is completely assembled and ready to bolt into place.

1. Bolt the actuator to 3" square tongue with two 1/2" x 4-1/2" bolts Gr.5 and 1/2" nylon insert lock nuts. Thin wall tongues require 3/4" O.D. x 11 gauge wall tubing as spacers inside the tongue. Tighten bolts to 75 - 80 ft. lbs. torque. Make sure coupler is free to telescope inside of outer case.
2. Connect and tighten all brake lines.
3. Fill the Master Cylinder (#23) with DOT 3 or 4 brake fluid.
4. Bleed the brake system using a pressure-type brake bleeder or manually, as follows:
 - a. Remove the two Self-Tapping Screws (#15) and Lock Washers (#16) that hold the flat Emergency Lever Spring (#17). Remove the Emergency Lever Spring. Using short strokes, pull forward on the Emergency Lever (#11), pumping the Master Cylinder until the brake fluid within the Master Cylinder stops bubbling.
 - b. Attach a bleeder hose to the bleeder valve on one of the wheels and submerge the other end of the hose into a clean, transparent container partially filled with brake fluid. Loosen the bleeder valve one turn and, watching the hose in the transparent container, use the Emergency Lever to pump the Master Cylinder as long as air bubbles continue to leave the hose. When the bubbles stop, close the bleeder valve, move to the next wheel, and repeat the process until all the brakes have been bled. (Note: Check the fluid level in the Master Cylinder frequently while bleeding the brakes (every 4 or 5 strokes). Refill as necessary to keep the level above half full.)

5. Once bleeding is completed, refill master cylinder to within 1/2" of top. and attach cap (#18) securely. Replace emergency lever spring, lever guide, lock washers and 5/16" hex head bolts. Wipe up any excess brake fluid immediately to prevent paint damage.
6. Test brakes by pulling emergency lever (#11) forward until it locks into its second notch position. (Lever should be approximately straight up.) Attempt to rotate wheels in a forward direction. If any wheels rotate, brakes must be adjusted. To adjust brakes, release emergency lever from locked position, set each wheels brake adjustment up 2 or 3 notches (per instructions in appropriate brake cluster manual). Repeat test procedure as necessary.

MAINTENANCE

1. Frequently check brake fluid level. (Fluid must be approved, clean and uncontaminated.)
2. Make sure actuator mounting bolts are secure, and coupler is free to telescope inside outer case.
3. Inspect actuator, replace bent, worn or damaged parts.
4. Be constantly aware of systems braking quality, make periodic checks as described in brakes owners manual. Consult certified brake specialist to make necessary adjustments or repairs. Failure to do so could result in loss of braking.

SERVICING THE EMERGENCY LEVER

If emergency lever (#11) of actuator is applied, it can be disengaged by using a screwdriver to lift upward on front of flat emergency lever spring (#17) while pulling lever forward until released. A thorough inspection of emergency lever, emergency lever spring, and cable with S-hooks is required. Damaged parts must be replaced as follows:

- a. Using two wrenches, loosen brake line from fitting (#24) at back of master cylinder (#23). Take care not to allow fitting to become loose in master cylinder.
- b. Remove cable S-hook (#14) from emergency lever (#11).
- c. Remove two bolts (#15) and emergency lever spring (#17).
- d. Press pushrod assembly (#8) rearward to allow emergency lever (#11) to pass by and remove it through cross slot in top of outer case (#21).
- e. To install new emergency lever, press pushrod assembly rearward and hold it there, while putting emergency lever through cross slot in top of outer case. Emergency lever should overlap front of pushplate when assembled properly.
- f. Install new emergency lever spring (#17) with bend upward, using two new self tapping bolts (#15).
- g. Install emergency cable with S-hook (#13) by inserting S-hook through hole in emergency lever (#11) and squeezing hook shut.
- h. Tighten fitting (#24) and brake line. Make sure to use two wrenches, so fitting isn't overtightened in master cylinder.
- i. Add brake fluid if necessary and bleed brake system as described per instructions 4-6 in the installation instructions.

DEMCO BRAKE PRODUCTS - LIMITED WARRANTY

1. **Extent and Duration of this Warranty:**

Your Demco brake product is warranted to be free from defects in materials and workmanship under normal use and service for a period of one year after date of purchase by original owner when properly installed, used and maintained by purchaser.

When this Demco brake product is used as part of complete Demco braking system (actuators, brake lines, and back plates), Demco warrants system to be free from defects in materials and workmanship for two years when properly installed, used, and maintained by purchaser.

Any part of Demco brake system found to be defective in materials or workmanship will be repaired or replaced at manufacturers option without charge for parts or labor to original owner.

2. **Manufacturer and Warrantor of Brake Actuator:**

Dethmers Manufacturing Co.
4010 320th Street
P.O. Box 189
Boyden, IA 51234
(712) 725-2311

3. **Repair or Replacement Procedure:**

If your Demco brake product develops a defect during warranty period, promptly notify Dethmers Manufacturing Co. customer service department. Until such notice is received, warrantor will not be responsible for any repair or replacement.

Upon receipt of timely notice from you, warrantor will have a choice of options in replacing any part it determines to be defective:

- a) Warrantor may require you at your own expense to deliver or ship part to its factory or authorized dealer. Any defective part will be repaired or replaced and returned to you or your authorized dealer free of charge. Any part returned to warrantor and found not to be defective will be returned to you freight collect with explanation.
- b) Warrantor may ship a new part to dealer to be exchanged free of charge for defective part returned by you.
- c) Warrantor may ship or deliver a replacement part to you at your address.

4. **Limitations on Warranty Coverage:**

Coverage under this warranty will be effective only when a copy of original invoice, showing date and location of purchase, accompanies any claim for warranty.

Warrantor has no liability whatsoever and this warranty is null and void if any Demco brake product has been misassembled or subjected to damage or neglect, negligence, misuse, accident or operated in any way contrary to operating and maintenance instructions as specified in Demco owners manual for that product.

This warranty does not cover any product that has been altered or modified so as to affect the product's operation, performance or durability, or that has been modified to change intended use of product.

In addition, warranty does not extend to repairs made necessary by abnormal use, damage, unreasonable use including failure to provide reasonable and necessary maintenance, or by use of parts, accessories or other equipment which are incompatible with Demco brake products or affect its operation, performance or durability.

DEMCO BRAKE PRODUCTS - LIMITED WARRANTY CONTINUED

This warranty does not cover:

- 1) normal wear and tear.
- 2) road film or gravel damage to paint.
- 3) paint.
- 4) rust damage.
- 5) any Demco brake product that has been loaded in excess of load capacity stated on identification label.
- 6) Accessory parts, materials or components.

Warrantor has a policy of continuous product improvement. We reserve the right to change or improve design of any Demco brake product, including but not limited to state of the art changes, without assuming any obligation to modify any product previously manufactured. Warrantor assumes no responsibility to owner for loss of use of product, loss of time, inconvenience or other damage consequential or otherwise, including, but not limited to expense for gasoline, expense of transporting product to dealer and expense of returning product, mechanics travel time, telephone, telegram, fax, overnight delivery, or postage charges, road service/towing charges, rental during time warranty repairs are being performed, travel, lodging, loss or damage to personal property or loss of revenue or earnings.

5. **Limitations of Implied Warranties:**

All implied warranties, if any, expire and terminate upon expiration of this warranty. Some states do not allow limitation on how long an implied warranty lasts, so this limitation may not apply to you.

6. **Limitation of Consequential Damages:**

Warrantor's responsibility under this warranty extends solely to repair or replacement of your Demco brake product and its component parts. Warrantor does not assume responsibility for, nor shall it be liable for, any special, incidental or consequential damages. Some states do not allow exclusion or limitation of incidental or consequential damages, so above exclusion or limitation may not apply to you.

7. **Purchasers Rights:**

This warranty gives you specific legal rights, and you may also have other rights which vary from state to state.

8. **Exclusive Warranty:**

This is the only express warranty made by Dethmers Manufacturing Co. on your Demco product and no agent, employee, or other person is allowed to change or add to this warranty. This warranty extends solely to repair or replacement of your Demco brake product and its component parts. Warrantor does not assume any liability or responsibility not expressly covered by this limited warranty. This warranty supersedes all prior warranties, written or implied.

DISCLAIMER

No other express warranty has been made or will be made on behalf of warrantor with respect to Demco brake product or its instruction, operation, repair or replacement. Warrantor shall not be responsible for damage, loss or damage to personal property, whether direct or indirect, and whether arising in contract or tort.



DETHMERS MFG. COMPANY

P.O. BOX 189

4010 320th St., BOYDEN, IA. 51234

PH: (712) 725-2311 FAX: (712) 725-2380

TOLL FREE: 1-800-54DEMCO (1-800-543-3626)

www.demco-products.com

Free Manuals Download Website

<http://myh66.com>

<http://usermanuals.us>

<http://www.somanuals.com>

<http://www.4manuals.cc>

<http://www.manual-lib.com>

<http://www.404manual.com>

<http://www.luxmanual.com>

<http://aubethermostatmanual.com>

Golf course search by state

<http://golfingnear.com>

Email search by domain

<http://emailbydomain.com>

Auto manuals search

<http://auto.somanuals.com>

TV manuals search

<http://tv.somanuals.com>