

**Montage- und
Gebrauchsanweisung**

Deutsch

**Installation and
Operating Instructions**

English

**Instructions d'installation
et d'utilisation**

Français

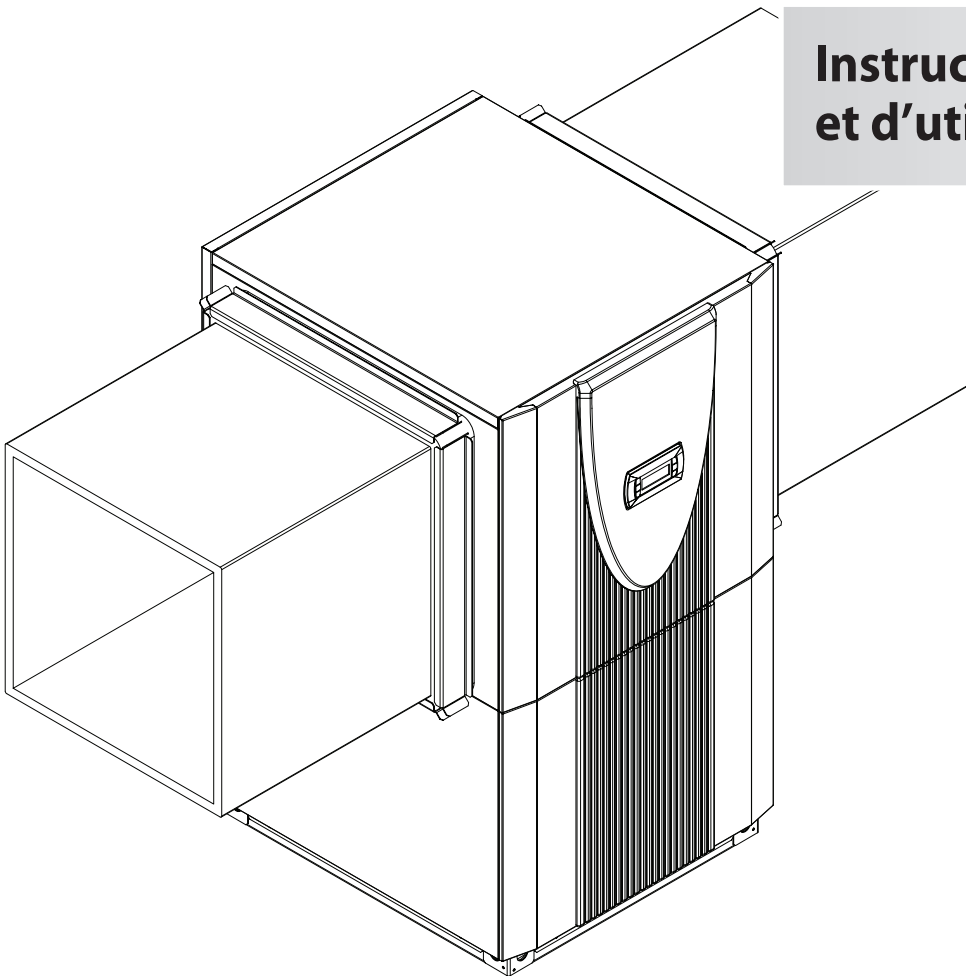

**Reversible
Luft/Wasser-
Wärmepumpe für
Innenaufstellung**

**Reversible
Air-to-Water
Heat Pump for
Indoor Installation**

**Pompe à chaleur
air-eau réversible
pour installation
intérieure**

Table of contents

1	Please Read Immediately	E-2
1.1	Important Information:.....	E-2
1.2	Legal Regulations and Directives	E-2
1.3	Energy-Efficient Use of the Heat Pump	E-2
2	Purpose of the Heat Pump	E-3
2.1	Application	E-3
2.2	Operating Principle	E-3
3	Scope of Delivery	E-3
3.1	Basic Device	E-3
3.2	Switch Box	E-4
4	Transport.....	E-4
5	Set-UP.....	E-5
5.1	General Information	E-5
5.2	Condensed Water Pipe.....	E-5
5.3	Sound	E-5
6	Installation	E-5
6.1	General Information	E-5
6.2	Air Connection	E-5
6.3	Heating System Connection	E-6
6.4	Electrical Connection	E-6
7	Start-UP	E-7
7.1	General Information	E-7
7.2	Preparation	E-7
7.3	Procedure	E-7
8	Maintenance / Cleaning	E-8
8.1	Maintenance	E-8
8.2	Cleaning the Heating System	E-8
8.3	Cleaning the Air System	E-8
9	Faults / Trouble-Shooting.....	E-8
10	Decommissioning/Disposal	E-8
11	Device Information	E-9
	Anhang / Appendix / Annexes	A-I

1 Please Read Immediately

1.1 Important Information:

ATTENTION!

The device is not suitable for operation with a frequency converter.

ATTENTION!

When transporting the heat pump, ensure that it is not tilted more than 45° (in any direction).

ATTENTION!

The heat pump and transport pallet are only joined by the packing film.

ATTENTION!

Do not restrict or block the area around the air intake or outlet.

ATTENTION!

Only operate the heat pump with the air ducts connected.

ATTENTION!

Never use cleaning agents containing sand, soda, acid or chloride as these can damage the surfaces.

ATTENTION!

We recommend the installation of a suitable corrosion protection system to prevent the formation of deposits (e.g. rust) in the condenser of the heat pump.

ATTENTION!

Before opening the device, ensure that all circuits are isolated from the power supply.

ATTENTION!

Any work on the heat pump may only be performed by authorised and qualified after-sales service technicians.

1.2 Legal Regulations and Directives

The construction and design of the heat pump complies with all relevant EU directives, DIN/VDE regulations (see CE declaration of conformity).

When connecting the heat pump to the power supply, the relevant VDE, EN and IEC standards are to be fulfilled. Any further connection requirements stipulated by local utility companies must also be observed.

When connecting the heating and/or cooling system, all applicable regulations must also be adhered to.

Persons, especially children, who are not capable of operating the device safely due to their physical, sensory or mental abilities or their inexperience or lack of knowledge, must not operate this device without supervision or instruction by the person in charge.

Children must be supervised to ensure that they do not play with the device.

1.3 Energy-Efficient Use of the Heat Pump

With the purchase of this heat pump you are helping to protect the environment. A prerequisite for energy-efficient operation is the correct design of the heat source system and heating (radiators and circulation pump) or cooling system.

It is particularly important for the efficient heating operation of a heat pump to keep the temperature difference between the heating water and the heat source as small as possible. For this reason, it is advisable to design the heat source and heating system very carefully. **A temperature difference of approx. one Kelvin increases the power consumption by around 2.5 %.** When designing the heating system, it should be borne in mind that special consumers such as e.g. hot water preparation should also be considered and dimensioned for low temperatures. **Underfloor heating systems (panel heating)** are optimally suited for heat pump use on account of the low flow temperatures (30 °C to 40 °C).

It is important to ensure that the heat exchangers are not contaminated during operation because this increases the temperature difference, in turn reducing the COP.

Correct adjustment of the heat pump controller is also important for energy-efficient use of the heat pump. Further information can be found in the heat pump controller's operating instructions.

2 Purpose of the Heat Pump

2.1 Application

The air-to-water heat pump is designed for use in existing or newly built heating systems.

It is designed exclusively for heating and cooling heating water!

In heating operation, the heat pump is suitable for mono energy and bivalent operation down to an external temperature of -20 °C.

Proper defrosting of the evaporator is guaranteed by maintaining a heating water return flow temperature of more than 18 °C during continuous operation.

The heat pump is not designed for the increased heat consumption required when a building is being dried out. The additional heat consumption should be met using special devices provided by the customer. If a building is to be dried out in autumn or winter, we recommend installing an additional heating element (available as an accessory).

In cooling operation the heat pump is suitable for temperatures ranging from +15 °C to +40 °C.

It can be used for silent and dynamic cooling. The minimum water temperature is +7 °C.

⚠ ATTENTION!

The device is not suitable for operation with a frequency converter.

2.2 Operating Principle

Heating

Surrounding air is drawn in by the ventilator and fed via the evaporator (heat exchanger). The evaporator cools the air, i.e. it extracts heat from it. This extracted heat is then transferred to the working medium (refrigerant) in the evaporator.

The heat is "pumped" to a higher temperature level by increasing its pressure with the aid of an electrically driven compressor. It is then transferred to the heating water using the liquifier (heat exchanger).

Electrical energy is used to raise the temperature of the heat in the environment to a higher level. Because the energy extracted from the air is transferred to the heating water, this type of device is called an air-to-water heat pump.

The air-to-water heat pump consists of the main components evaporator, ventilator and expansion valve, as well as the low-noise compressor, liquifier and electrical control system.

At low ambient temperatures, humidity accumulates on the evaporator in the form of frost reducing the transfer of heat. The evaporator is defrosted automatically by the heat pump as required. Steam may be emitted from the air outlet depending on the atmospheric conditions.

Cooling

The functions of the evaporator and the liquifier are reversed in the "Cooling" operating mode.

The heating water transfers its heat to the refrigerant via the liquifier which is now functioning as an evaporator. The refrigerant is pumped to a higher temperature level using the compressor. Heat is passed on to the surrounding air via the liquifier (functioning as an evaporator in heating operation).

3 Scope of Delivery

3.1 Basic Device

The heat pump is of compact design and is supplied complete with the components listed below.

R404A is used as the refrigerant.

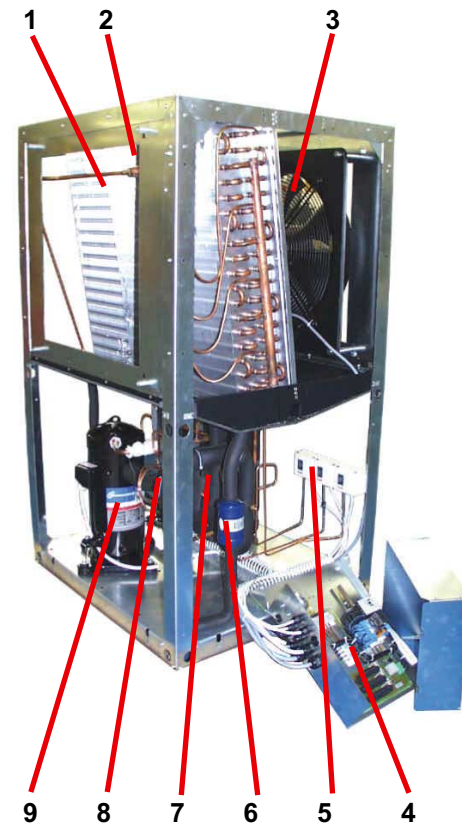

- 1) Evaporator (heating operation)
- 2) Check valve
- 3) Ventilator
- 4) Switch box
- 5) Pressure switches
- 6) Filter dryer
- 7) Liquifier (heating operation)
- 8) Expansion valve
- 9) Compressor

3.2 Switch Box

The switch box is located in the heat pump. It can be swung out after removing the lower front cover and loosening the fastening screw located in the upper right-hand corner.

The switch box contains the supply connection terminals, as well as the power contactors, the soft starter unit and the heat pump manager.

The heat pump manager is a convenient electronic regulation and control device. It controls and monitors the entire heating or cooling system on the basis of the external temperature, including hot water preparation and safety systems.

The customer must install the external temperature sensor, which is included in the scope of supply of the heat pump controller together with the necessary fixing accessories.

The enclosed operating instructions describe the function and use of the heat pump manager.

4 Transport

⚠ ATTENTION!

When transporting the heat pump, ensure that it is not tilted more than 45° (in any direction).

Use a wooden pallet for transporting the heat pump to the final installation location. The basic device can be transported with a lift truck, hand truck or by means of 3/4" pipes fed through the holes in the base plate or frame.

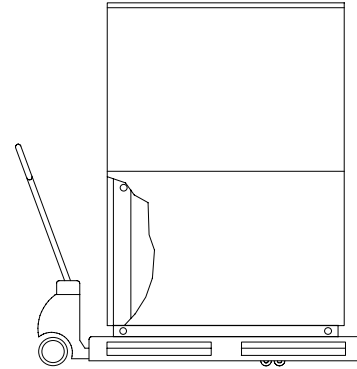

⚠ ATTENTION!

The heat pump and transport pallet are only joined by the packing film.

Before using the transport holes in the frame, it is necessary to remove the lower side panel assemblies. This is done by loosening each of the two screws at the base and then withdrawing the panels by unhooking them from above. Rehang the panels by gently pushing them in an upwards direction.

Be careful not to damage any components when inserting the pipes through the frame.

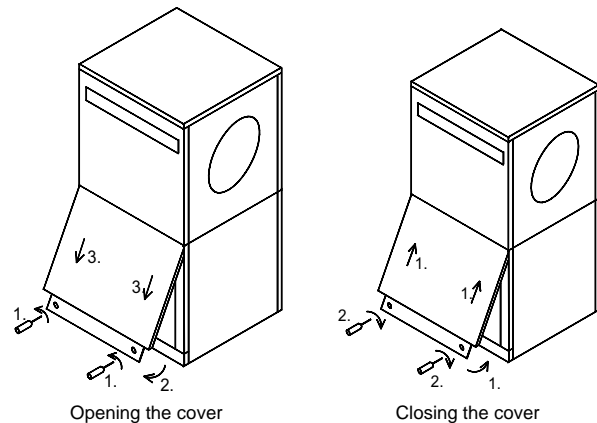

5 Set-UP

5.1 General Information

The unit must be installed indoors on a level, smooth and horizontal surface. The entire base of the frame should lie directly on the floor to ensure a good soundproof seal. If this is not the case, additional sound insulation measures may be necessary. If the device is installed on top of a built-under buffer tank, a surface that fully supports the base is required. The heat pump must be installed so that maintenance work can be carried out without being hindered. This can be ensured by maintaining a clearance of 1 m in front and to the left and right of the heat pump.

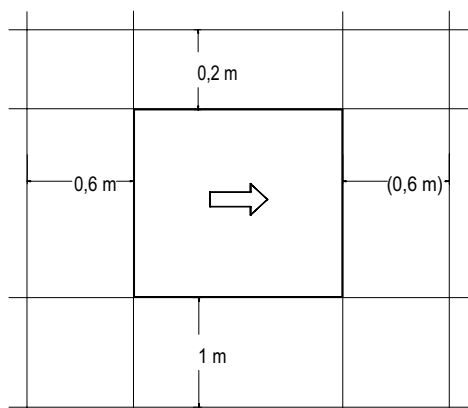

Never install the device in rooms subject to high humidity. Condensation can form on the heat pump and air circuit if the humidity exceeds 50% and the external temperature is below 0 °C.

If the heat pump is installed on an upper storey, the load-bearing capacity of the ceiling should be checked. On account of the acoustics, measures for isolating possible vibrations should also be very carefully planned in advance as well. Installation on a wooden floor is not recommended.

5.2 Condensed Water Pipe

Condensed water that forms during operation must be drained off frost-free. The heat pump must be mounted on a level plane to guarantee proper drainage. The condensed water pipe must have a minimum diameter of 50 mm and should be fed frost-free into a sewer. Condensate should not be discharged directly into clearing tanks and cesspits because the aggressive vapours could destroy the evaporator.

5.3 Sound

To prevent solid-borne sound from being transmitted to the heating system, we recommend connecting the heat pump to the heating system using a flexible hose.

Installed air ducts should be sound-isolated from the heat pump to prevent the transmission of solid-borne sound to the ducts.

6 Installation

6.1 General Information

The following connections need to be established on the heat pump:

- Fresh and exhaust air
- Flow and return flow of the heating system
- Condensate outflow
- Power supply

6.2 Air Connection

⚠ ATTENTION!

Do not restrict or block the area around the air intake or outlet.

⚠ ATTENTION!

Only operate the heat pump with the air ducts connected.

The glass fibre reinforced concrete air ducts offered as accessories are moisture-resistant and diffusion-free.

The sealing collar is used to seal the air ducts on the heat pump. The air ducts are not screwed directly onto the heat pump. Only the rubber seal comes into direct contact with the heat pump when the system is installed correctly. This guarantees easy assembly and disassembly of the heat pump and also ensures that solid-borne sound is well insulated.

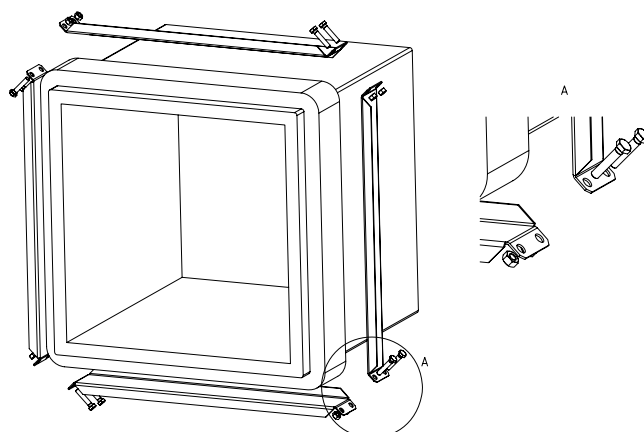

If another type of air duct is used, observe the external and internal dimensions as specified in the figure. Also ensure that the vibration and duct insulation are adequate.

If flange-mounted air ducts are used, connecting stubs are secured on the air inlet and air outlet sides of the evaporator with 4 M8 x 16 hexagon bolts in the threaded holes provided. When doing this, ensure that both air duct stubs only touch the insulation. There should be no contact with the external sheeting.

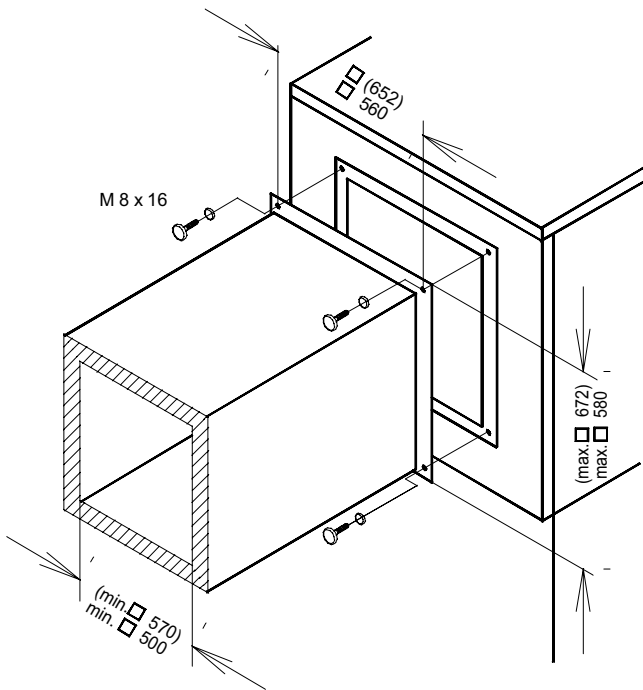

The values in parentheses are valid for the LI 16TE

6.3 Heating System Connection

The heating system connections on the heat pump have a 1¼" external thread. Use a spanner to firmly grip the transitions when connecting the heat pump.

Before connecting the heating water system to the heat pump, the heating system must be flushed to remove any impurities, residue from sealants, etc. Any accumulation of deposits in the liquifier could cause the heat pump to completely break down. For systems in which the heating water flow can be shut off via the radiator or thermostat valves, an overflow valve must be installed in a heating bypass behind the heat pump by the customer. This ensures a minimum heating water flow rate through the heat pump and helps to avoid faults.

Once the heating system has been installed, it must be filled, de-aerated and pressure-tested.

Minimum heating water flow rate

The minimum heating water flow rate through the heat pump must be assured in all operating states of the heating system. This can be accomplished, for example, by installing either a manifold without differential pressure or an overflow valve. The procedure for adjusting an overflow valve is described in the Chapter Start-Up.

Antifreeze

A method of manual drainage (see illustration) should be provided for heat pumps which are exposed to frost. The antifreeze function of the heat pump controller is active whenever the controller and the heat circulating pump are ready for operation. If the heat pump is taken out of service or in the event of a power failure, the system has to be drained. The heating circuit should be operated with a suitable antifreeze if heat pump systems are implemented in buildings where a power failure can not be detected (holiday home).

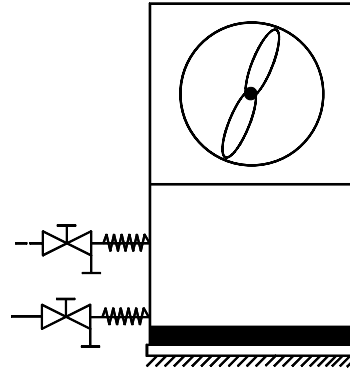

6.4 Electrical Connection

The power supply and control voltage are supplied using standard cables (load: 3-core, control: 3-core).

For detailed instructions on how to connect the external components and how the heat pump controller functions, please refer to the device connection diagram and the operating manual supplied with the controller.

A disconnecting device with a contact gap of at least 3 mm (e.g. utility blocking contactor or power contactor) as well as a 1-pole circuit breaker must be installed in the power supply of the heat pump by the customer (tripping current in compliance with the Device Information).

The control voltage must be protected by a 10 A fuse.

For detailed information, see Circuit Diagrams in the Appendix.

7 Start-UP

7.1 General Information

To ensure that start-up is performed correctly, it should only be carried out by an after-sales service technician authorised by the manufacturer. This may be a condition for extending the guarantee (see Warranty Service). Start-up should be carried out in heating operation.

7.2 Preparation

The following items need to be checked prior to start-up:

- All of the heat pump connections must be established as described in Chapter 6.
- All valves that could impair the proper flow of the heating water in the heating circuit must be open.
- The air intake and air outlet paths must be clear.
- The ventilator must turn in the direction indicated by the arrow.
- The settings of the heat pump controller must be adapted to the heating system in accordance with the controller's operating instructions.
- Ensure the condensate outflow functions.

7.3 Procedure

The heat pump is started up via the heat pump controller. Adjustments should be made in compliance with the instructions.

If an overflow valve is fitted to maintain the minimum heating water flow rate, the valve must be adapted to the requirements of the heating system. Incorrect adjustment can lead to faulty operation and increased energy consumption. We recommend carrying out the following procedure to correctly adjust the overflow valve:

Close all of the heating circuits that may also be closed during operation (depending on the type of heat pump usage) so that the most unfavourable operating state - with respect to the water flow rate - is achieved. This normally means the heating circuits of the rooms on the south and west sides of the building. At least one heating circuit must remain open (e.g. bathroom).

The overflow valve should be opened far enough to produce the maximum temperature spread between the heating flow and return flow listed in the following table for the current heat source temperature. The temperature spread should be measured as close as possible to the heat pump. The heating element of mono energy systems should be disconnected.

Heat source temperature		Max. temperature spread between heating flow and return flow
From	To	
-20 °C	-15 °C	4 K
-14 °C	-10 °C	5 K
-9 °C	-5 °C	6 K
-4 °C	0 °C	7 K
1 °C	5 °C	8 K
6 °C	10 °C	9 K
11 °C	15 °C	10 K
16 °C	20 °C	11 K
21 °C	25 °C	12 K
26 °C	30 °C	13 K
31 °C	35 °C	14 K

Any faults occurring during operation are also displayed on the heat pump controller and can be corrected as described in the operating instructions of the heat pump controller.

For external temperatures below 10 °C and heating water temperatures below 16 °C, the buffer tank should be heated up with the 2nd heat generator to at least 25 °C.

Observe the following procedure to implement a smooth start-up:

- 1) Close all of the heating circuits.
- 2) Fully open the overflow valve.
- 3) Use the controller to select the automatic operating mode.
- 4) Wait until the buffer tank has reached a temperature of at least 25 °C.
- 5) Now slowly reopen the heating circuit valves in succession so that the heating water throughput is constantly raised by slightly opening the respective heating circuit. The heating water temperature in the buffer tank must not be allowed to drop below 20 °C during this process. This ensures that the heat pump can be defrosted at any time.
- 6) Set the minimum volume flow quantity on the overflow valve and heat circulating pump when all heating circuits are fully open and a heating water temperature in the buffer tank of approx. 20 °C is maintained.
- 7) New buildings have an increased heat consumption on account of the energy required to dry them out. This increased heat consumption means that marginally dimensioned heating systems can not always achieve the desired room temperature. In such cases, we recommend keeping a 2nd heat generator on standby during the first heating period. The limit temperature on the heat pump controller should also be turned up to 15 °C.

8 Maintenance / Cleaning

8.1 Maintenance

To protect the paintwork, avoid leaning or putting objects on the device. External heat pump parts can be wiped with a damp cloth and domestic cleaner.

⚠ ATTENTION!

Never use cleaning agents containing sand, soda, acid or chloride as these can damage the surfaces.

To prevent faults due to sediment in the heat exchanger of the heat pump, ensure that the heat exchanger in the heating system can not be contaminated. We recommend protecting the evaporator by installing a bird guard in the inlet duct. At least 80% of the cross section of the grating should be open. In the event that operating malfunctions due to contamination still occur, the system should be cleaned as described below.

8.2 Cleaning the Heating System

The ingress of oxygen into the heating water circuit may result in the formation of oxidation products (rust), particularly if steel components are used. These products enter the heating system via the valves, the circulating pumps and/or plastic pipes. It is therefore essential - in particular with respect to the piping of underfloor heating systems - that only diffusion-proof materials are used.

⚠ ATTENTION!

We recommend the installation of a suitable corrosion protection system to prevent the formation of deposits (e.g. rust) in the condenser of the heat pump.

Residue from lubricants and sealants may also contaminate the heating water.

In the case of severe contamination leading to a reduction in the performance of the liquifier in the heat pump, the system must be cleaned by a heating technician.

According to today's state of knowledge, we recommend using a 5 % phosphoric acid solution for cleaning purposes. However, if cleaning needs to be performed more frequently, a 5 % formic acid solution should be used.

In either case, the cleaning fluid should be at room temperature. We recommend flushing the heat exchanger in the direction opposite to the normal flow direction.

To prevent acidic cleaning agents from entering the heating system circuit, we recommend connecting the flushing device directly to the flow and return flow of the liquifier of the heat pump.

It is important that the system be thoroughly flushed using appropriate neutralising agents to prevent any damage from being caused by cleaning agent residue remaining in the system.

Acids must be used with great care and all relevant regulations of the employers' liability insurance associations must be adhered to.

If in doubt, contact the manufacturer of the chemicals!

8.3 Cleaning the Air System

Air ducts, evaporator, ventilator and condensate outflow should be cleaned of contamination (leaves, twigs, etc.) before the heating period. Do this by opening the front of the heat pump. The bottom should be opened first followed by the top.

⚠ ATTENTION!

Before opening the device, ensure that all circuits are isolated from the power supply.

Remove and rehang the side panel assemblies as described in Chapter 4.

To prevent the evaporator and the condensate tray from being damaged, do not use hard or sharp objects for cleaning.

9 Faults / Trouble-Shooting

This heat pump is a quality product and is designed for trouble-free and maintenance-free operation. In the event that a fault should occur, it will be shown on the heat pump manager display. Simply consult the Faults and Trouble-shooting page in the operating instructions of the heat pump manager. If you cannot correct the fault yourself, please contact your after-sales service technician.

⚠ ATTENTION!

Any work on the heat pump may only be performed by authorised and qualified after-sales service technicians.

10 Decommissioning/ Disposal

Before removing the heat pump, disconnect it from the power source and close all valves. Observe all environmentally-relevant requirements regarding the recovery, recycling and disposal of materials and components in accordance with all applicable standards. Particular attention should be paid to the proper disposal of refrigerants and refrigeration oils.

11 Device Information

1	Type and order code		LI 11MER	
2	Design			
2.1	Model		Reversible	
2.2	Degree of protection according to EN 60 529		IP 21	
2.3	Installation location		Indoors	
3	Performance data			
3.1	Operating temperature limits:			
	Heating water flow/return flow	°C / °C	Up to 58 / above 18	
	Cooling, flow	°C	+7 to +20	
	Air (heating)	°C	-25 to +35	
	Air (cooling)	°C	+15 to +40	
3.2	Temperature spread of heating water			
	at A7 / W35	K	9.6	5.0
3.3	Heat output / COP			
	at A-7 / W35 ¹	kW / ---	7.5 / 2.8	7.0 / 2.7
	at A-7 / W45 ¹	kW / ---		6.8 / 2.3
	at A2 / W35 ¹	kW / ---	8.9 / 3.4	8.8 / 3.3
	at A7 / W35 ¹	kW / ---	11.1 / 4.2	11.1 / 4.0
	at A7 / W45 ¹	kW / ---		9.4 / 3.5
	at A10 / W35 ¹	kW / ---	12.1 / 4.6	12.0 / 4.4
3.4	Temperature spread of cooling water			
	at A35 / W7	K	6.5	5.0
3.5	Cooling capacity / COP			
	at A27 / W7	kW / ---	8.8 / 2.8	8.8 / 2.8
	at A27 / W18	kW / ---	10.9 / 3.3	10.8 / 3.2
	at A35 / W7	kW / ---	7.6 / 2.1	9.5 / 2.5
	at A35 / W18	kW / ---	9.5 / 2.5	9.5 / 2.5
3.6	Sound power level device / outdoors	dB(A)	55 / 61	
3.7	Sound pressure level at a distance of 1 m (indoors)	dB(A)	50	
3.8	Heating water flow with an internal pressure differential of m ³ /h / Pa		1.0 / 3000	1.9 / 10900
3.9	Cooling water flow with an internal pressure differential of m ³ /h / Pa		1.0 / 3000	1.3 / 5900
3.10	Air flow rate with an external static pressure differential of m ³ /h / Pa		4200 / 0	
		m ³ /h / Pa	2500 / 25	
3.11	Refrigerant; total filling weight	Type / kg	R404A / 3.6	
4	Dimensions, connections and weights			
4.1	Device dimensions	H x W x L cm	136 x 75 x 88	
4.2	Device connections to heating system	Inch	G 1 1/4" external	
4.3	Air duct inlet and outlet (min. internal dimensions)	L x W cm	50 x 50	
4.4	Weight of the transportable unit(s) incl. packing	kg	205	
5	Electrical Connection			
5.1	Nominal voltage; fuse protection	V / A	230 / 25	
5.2	Nominal power consumption ¹ A2 W35	kW	2.61	2.67
5.3	Starting current with soft starter	A	38	
5.4	Nominal current A2 W35 / cosφ	A / ---	14.2 / 0.8	14.5 / 0.8
6	Complies with the European safety regulations		2	
7	Additional model features			
7.1	Defrosting		Automatic	
	Type of defrosting		Reverse cycle	
	Defrosting tray included		Yes (heated)	
7.2	Heating water in device protected against freezing		Yes ³	
7.3	Performance levels		1	
7.4	Controller internal/external		External	

1. This data indicates the size and capacity of the system. For an analysis of the economic and energy efficiency of the system, other parameters, such as, in particular, the defrosting capacity, the bivalence point and regulation, should also be taken into consideration. The specified values, e.g. A2 / W55, have the following meaning: External temperature 2 °C and heating water flow temperature 55 °C.

2. See CE declaration of conformity

3. The heat circulating pump and the heat pump controller must always be ready for operation.

Anhang / Appendix / Annexes

1	Maßbild / Dimension Drawing / Schéma coté	A-II
2	Diagramme / Diagrams / Diagrammes	A-III
2.1	Heizbetrieb / Heating Operation / Mode chauffage.....	A-III
2.2	Kühlbetrieb / Cooling Operation / Mode refroidissement	A-IV
3	Stromlaufpläne / Circuit Diagrams / Schémas électriques	A-V
3.1	Steuerung Standardregler / Control of the standard controller / Commande régulateur standard	A-V
3.2	Steuerung Kühlregler / Control of the cooling controller / Commande régulateur standard	A-VI
3.3	Last / Load / Charge	A-VII
3.4	Anschlussplan Standardregler / Terminal diagram for the standard controller / Schéma électrique du régulateur standard.....	A-VIII
3.5	Anschlussplan Kühlregler / Terminal diagram for the cooling controller / Schéma électrique du régulateur refroidissement	A-IX
3.6	Legende / Legend / Légende.....	A-X
4	Hydraulische Prinzipschemen / Hydraulic Plumbing Diagrams / Schémas hydrauliques ...	A-XI
4.1	Darstellung / Schematic View / Représentation.....	A-XI
4.2	Legende / Legend / Légende.....	A-XII
5	Konformitätserklärung / Declaration of Conformity / Déclaration de conformité	A-XIII

1 Maßbild / Dimension Drawing / Schéma coté

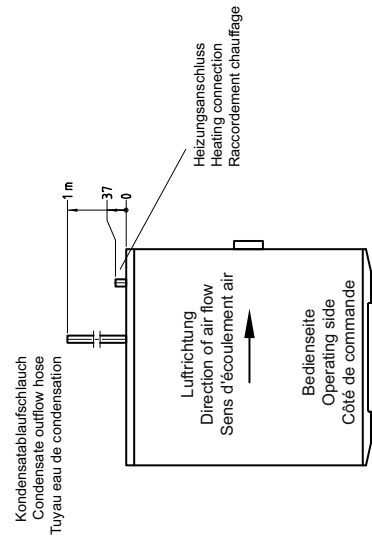
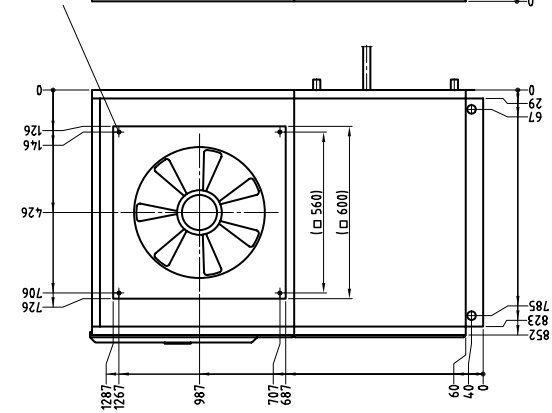
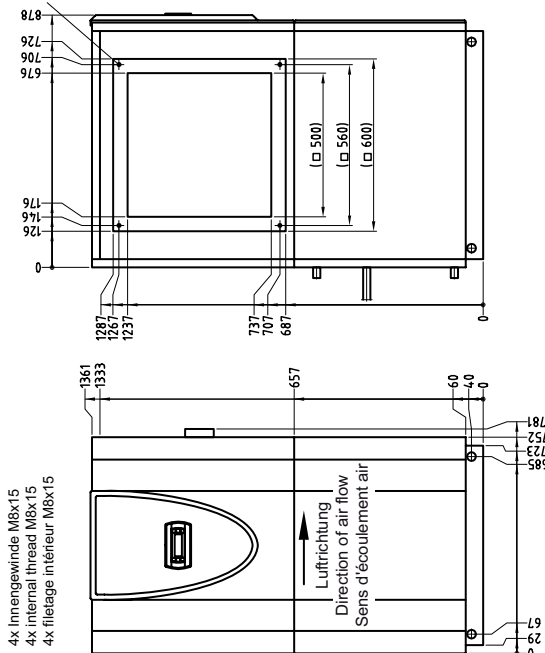
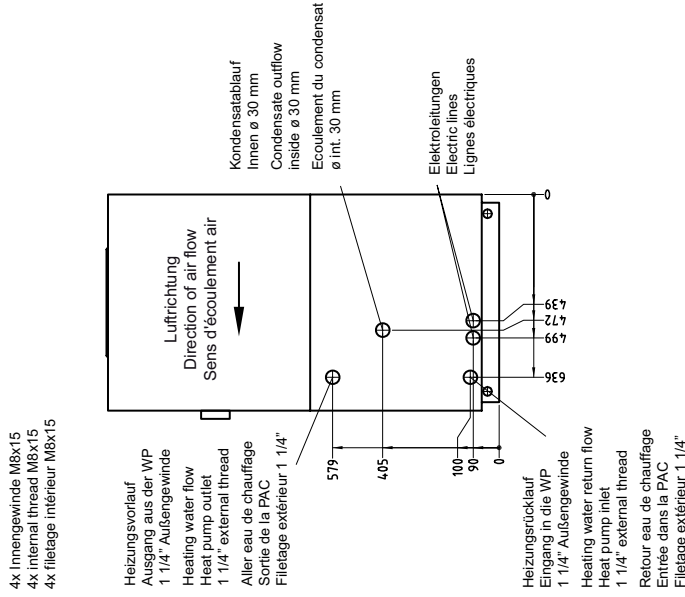

Anhang · Appendix · Annexes

2 Diagramme / Diagrams / Diagrammes

2.1 Heizbetrieb / Heating Operation / Mode chauffage

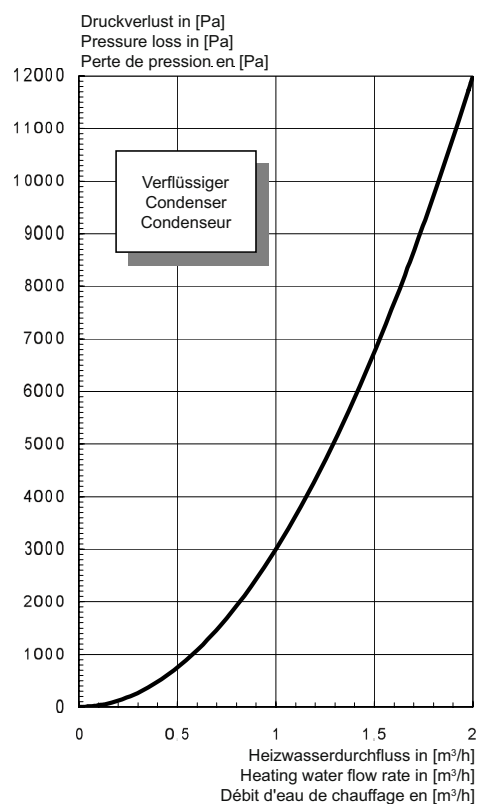
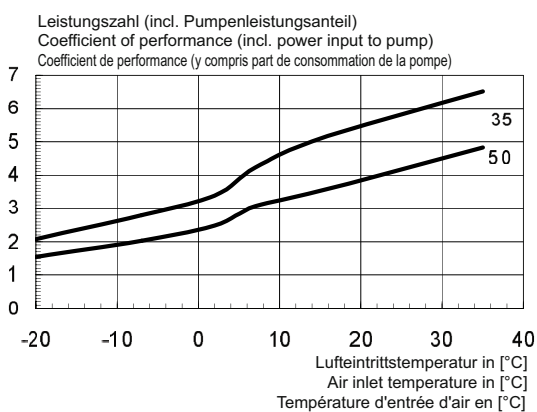
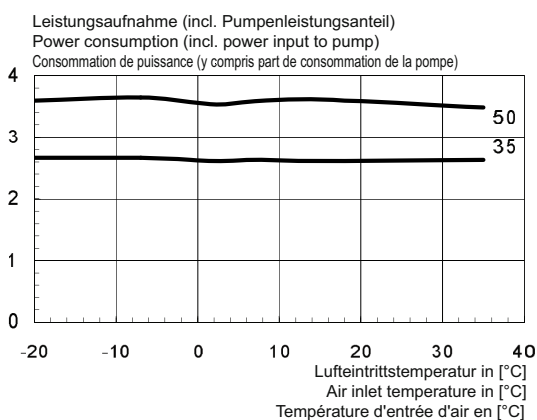
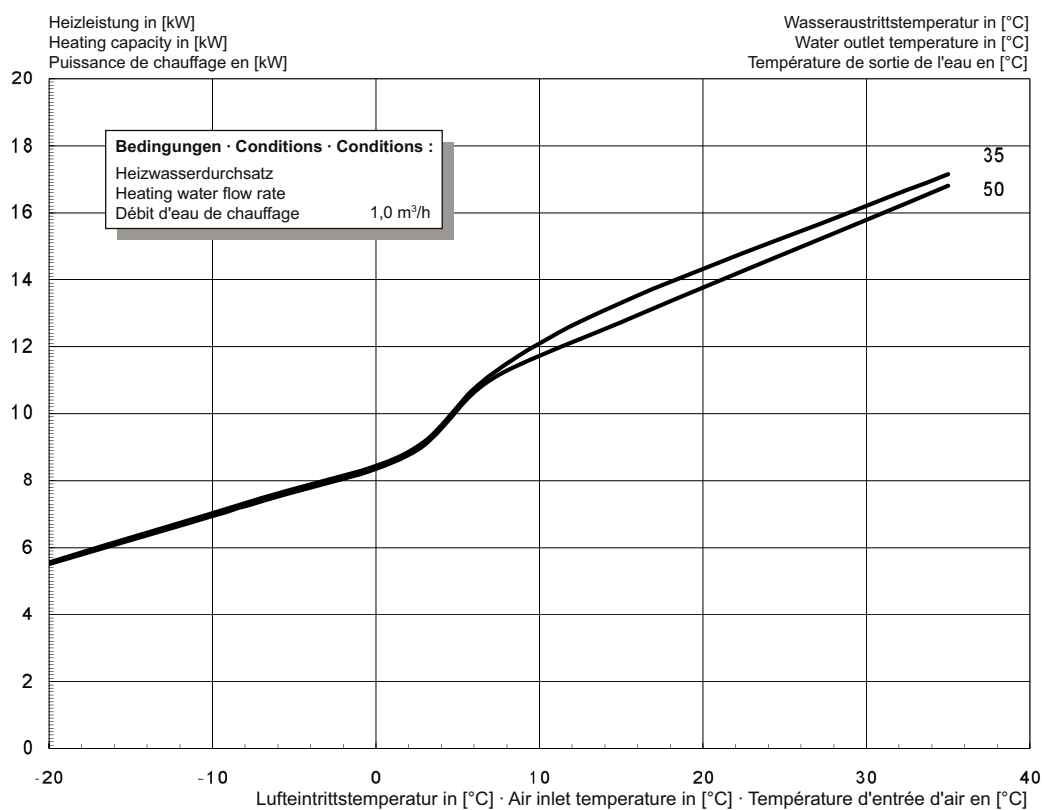

2.2 Kühlbetrieb / Cooling Operation / Mode refroidissement

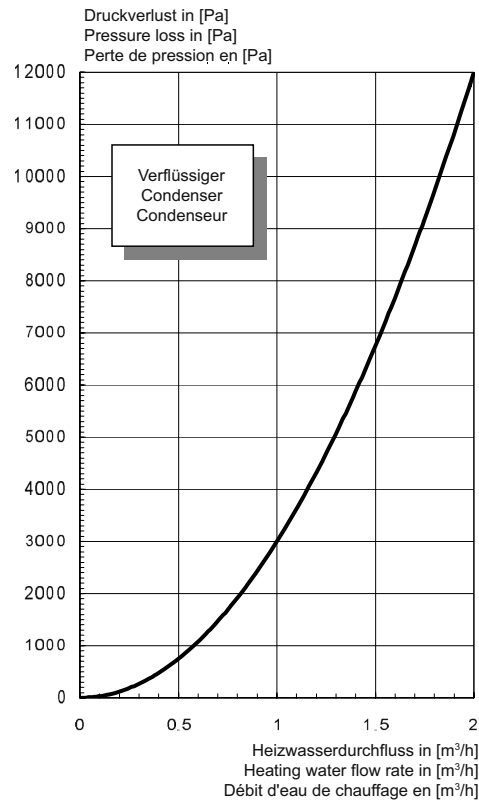
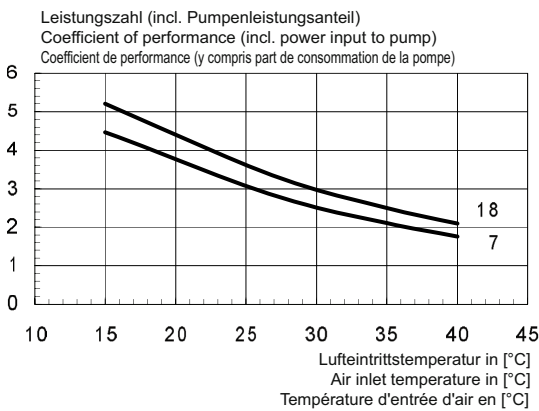
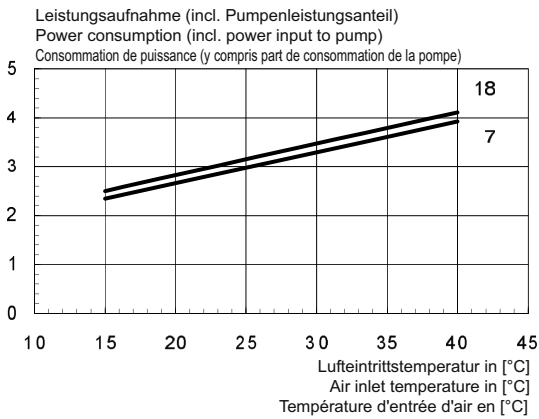
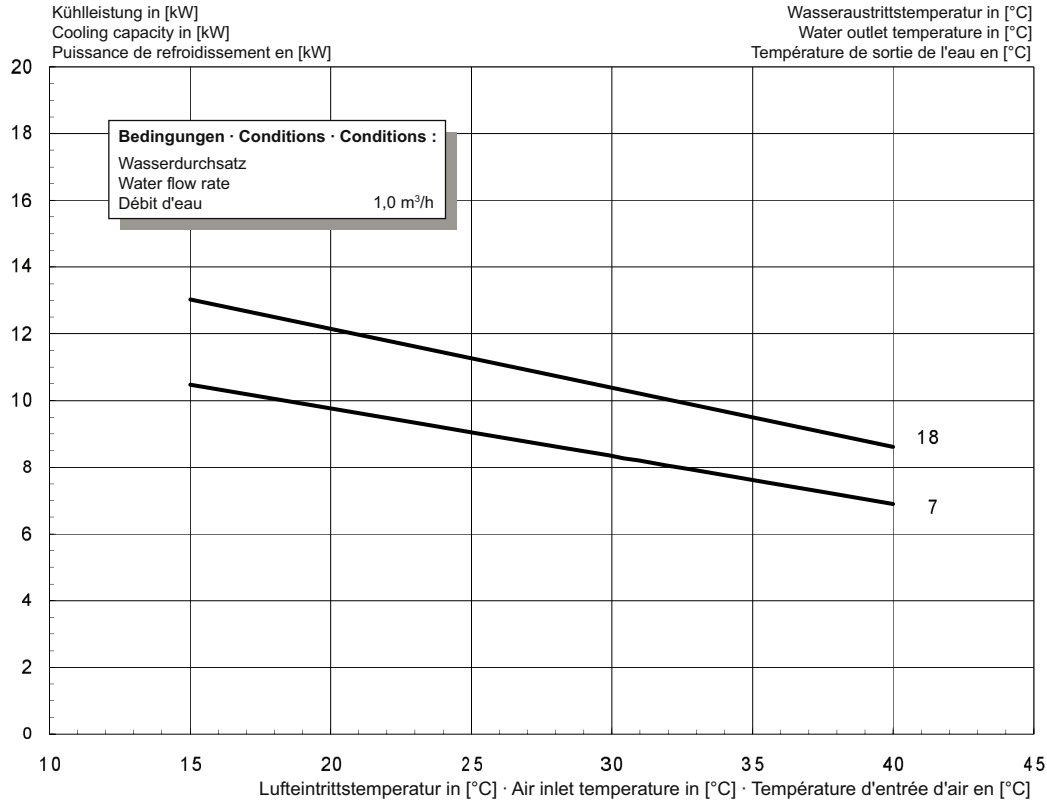

Anhang · Appendix · Annexes

3 Stromlaufpläne / Circuit Diagrams / Schémas électriques

3.1 Steuerung Standardregler / Control of the standard controller / Commande régulateur standard

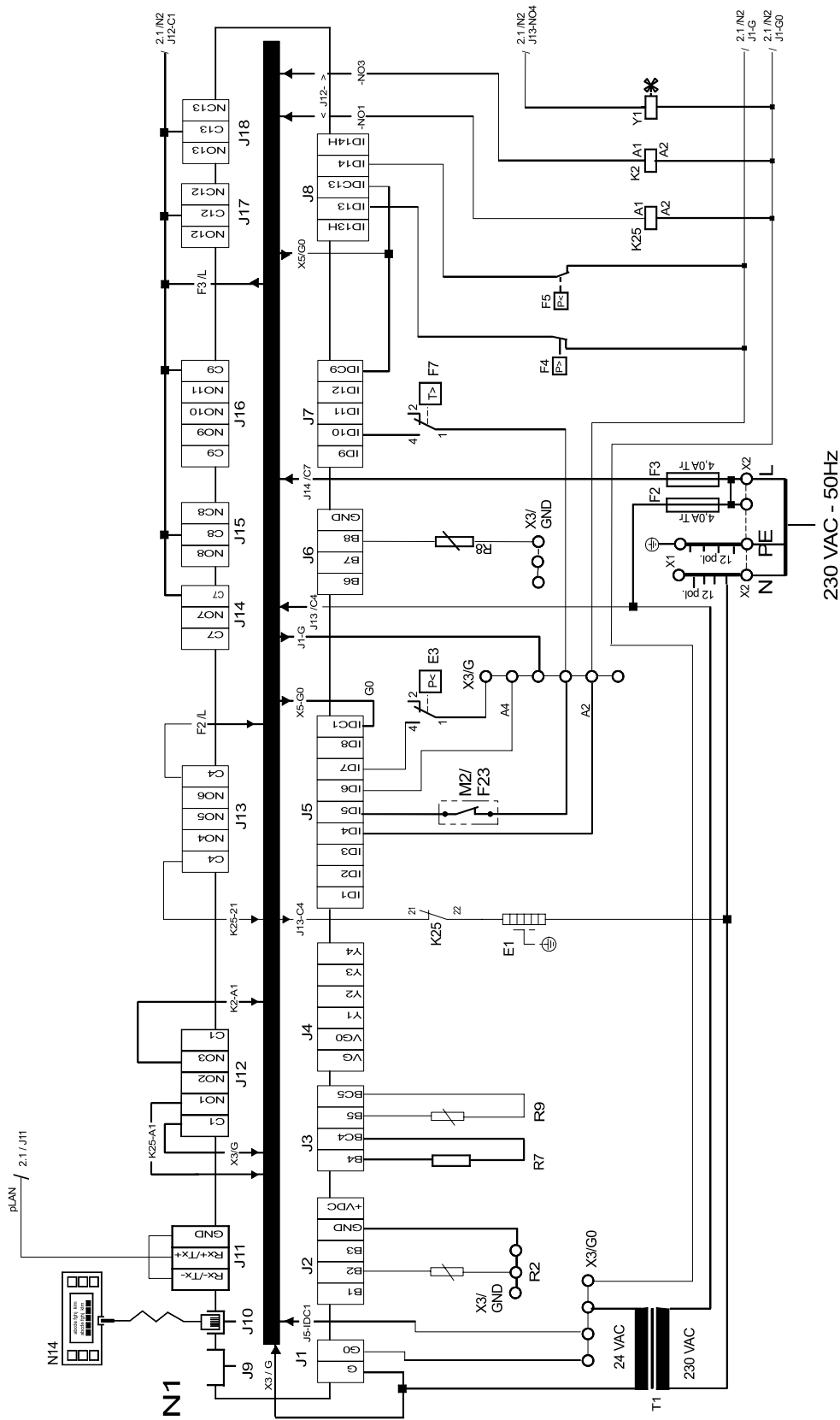

3.2 Steuerung Kühlregler / Control of the cooling controller / Commande régulateur standard

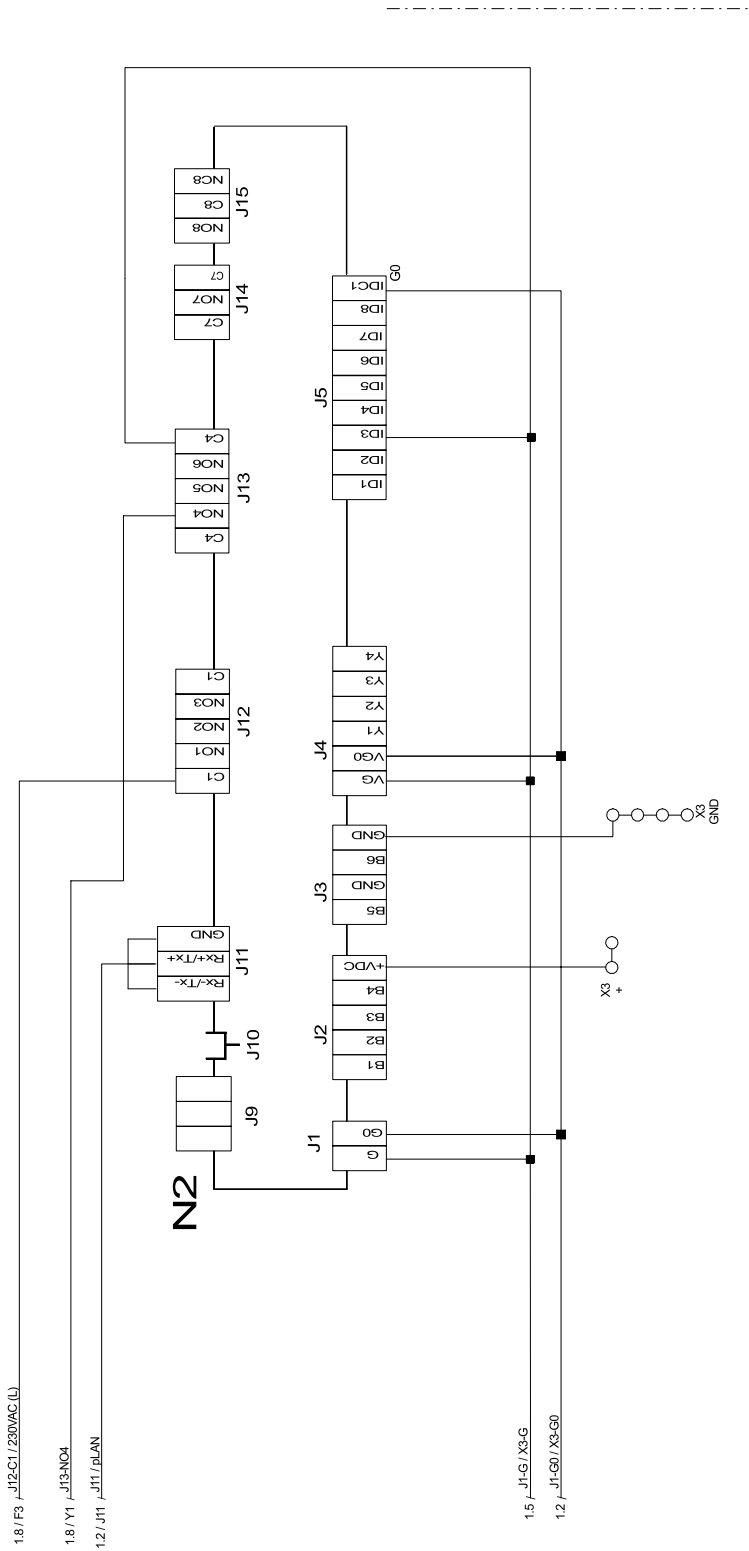

Anhang · Appendix · Annexes

3.3 Last / Load / Charge

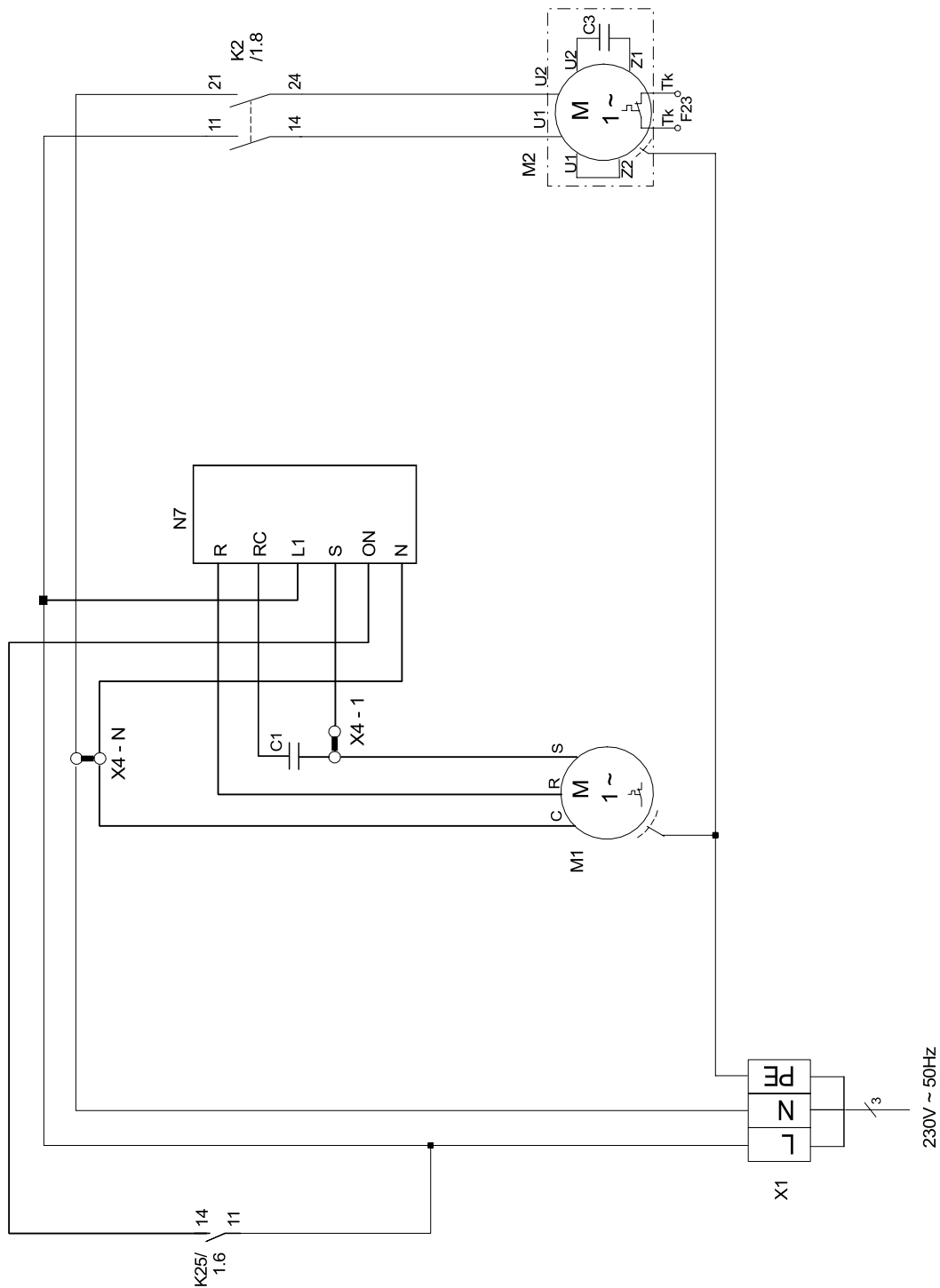

3.4 Anschlussplan Standardregler / Terminal diagram for the standard controller / Schéma électrique du régulateur standard

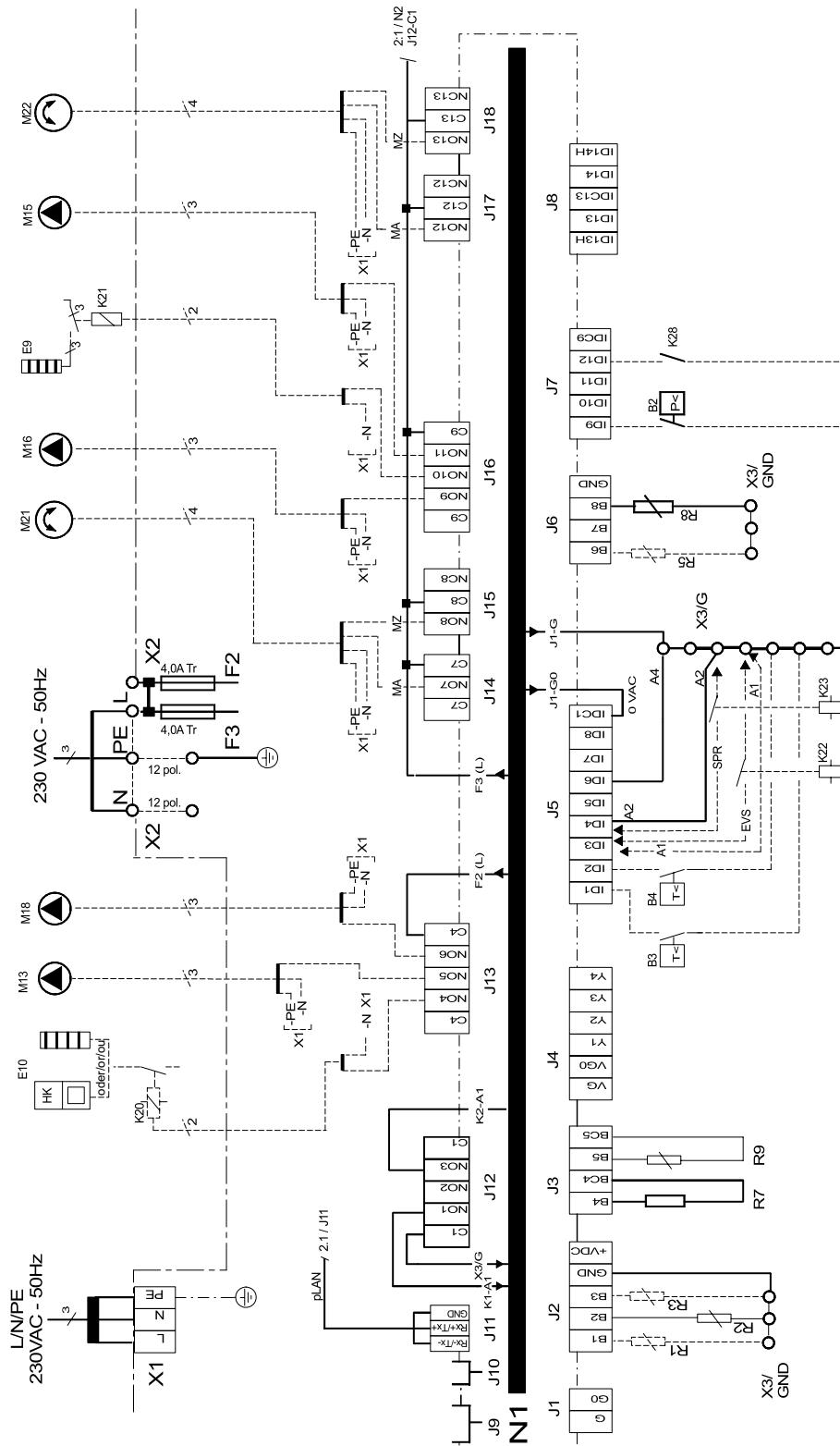

Anhang · Appendix · Annexes

3.5 Anschlussplan Kühlregler / Terminal diagram for the cooling controller / Schéma électrique du régulateur refroidissement

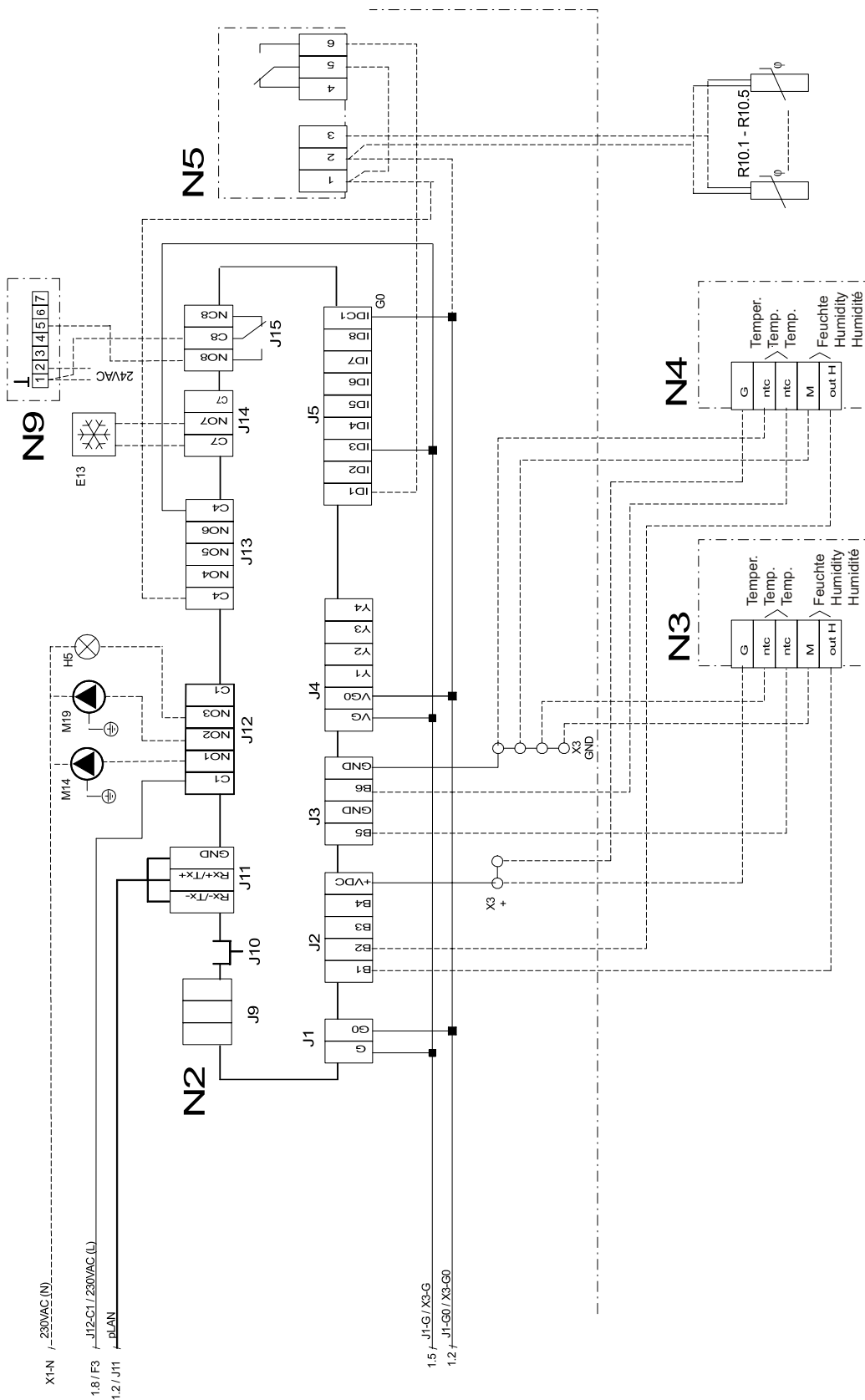

3.6 Legende / Legend / Légende







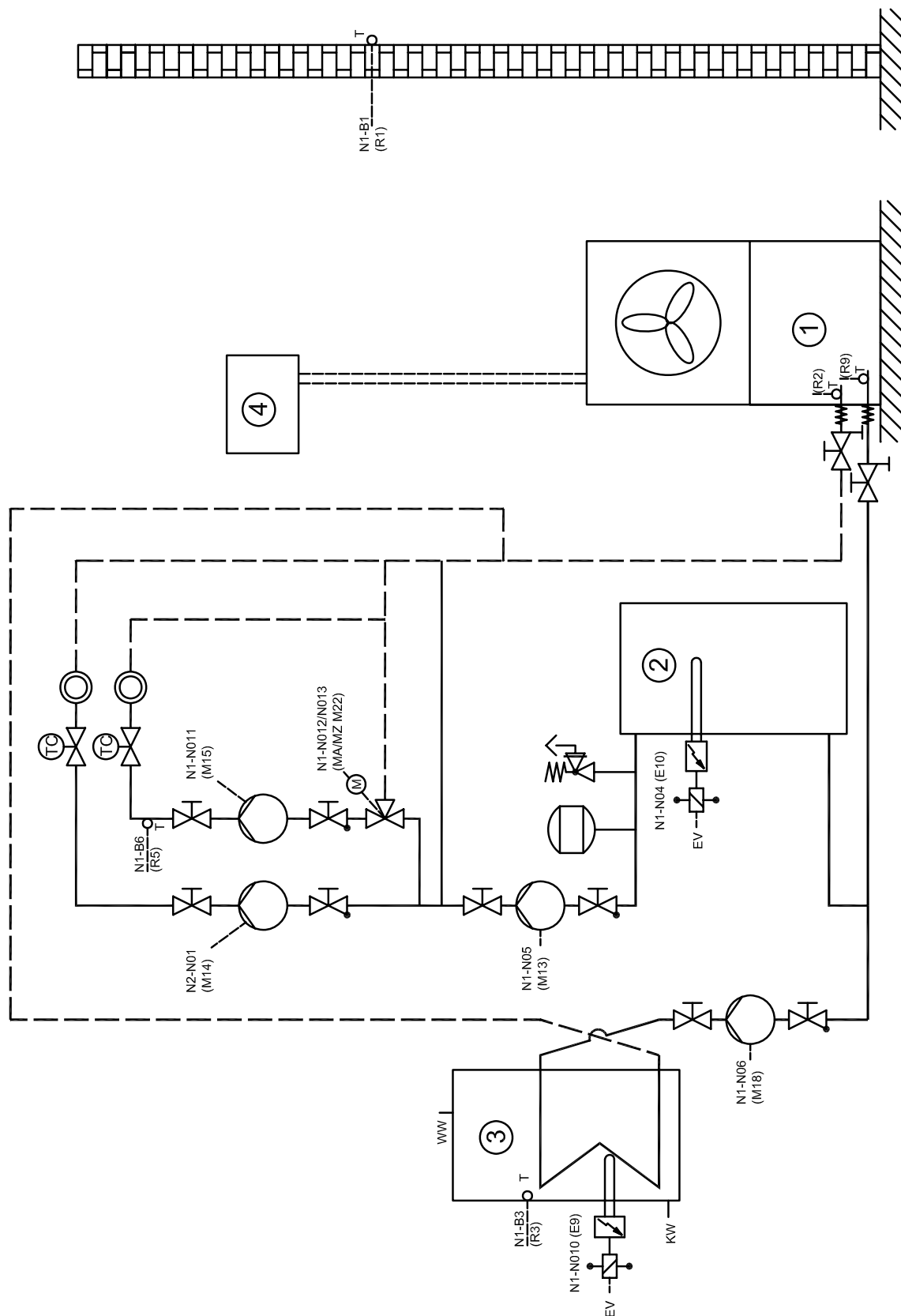



A1	Drahtbrücke, muss eingelegt werden, wenn kein Sperrschütz vorhanden ist	Wire jumper, must be inserted if no blocking contactor is fitted	Le cavalier à fil doit être inséré en absence de disjoncteur de blocage du fournisseur d'énergie.
A2	Drahtbrücke, muss bei Verwendung des 2ten Sperringanges entfernt werden	Wire jumper, must be removed if the 2nd disable contactor is used	Cavalier à fil à retirer si la 2e entrée de coupure est utilisée
A4	Drahtbrücke, muss bei Einsatz eines Motorschutzkontaktes, für den Verdichter, entfernt werden Offene Drahtbrücken oder Kontakte bedeuten Sperre oder Störung	Wire jumper, must be removed when a motor protection contact is used for the compressor Open wire jumpers or contacts mean: block or fault	Retirer le cavalier à fil si utilisation d'un contact de disjoncteur de moteur, pour le compresseur Cavaliers à fil ou contacts ouverts signifient coupure ou panne
B3*	Thermostat Warmwasser	Hot water thermostat	Thermostat eau chaude
B4*	Thermostat Schwimmbadwasser	Swimming pool water thermostat	Thermostat eau de piscine
E1	Ölsumpfheizung	Oil sump heater	Chauffage carter à huile
E3	Pressostat Abtauende	Defrost end controller	Pressostat fin de dégivrage
E9*	Elekt. Tauchheizkörper-Warmwasser	Electric immersion heater hot water	Thermoplongeur électr. eau chaude
E10*	2. Wärmeerzeuger Elektroheizung (Funktion ist über Regler wählbar)	2nd heat generator, electric heating (function selectable via controller)	2e générateur de chaleur chauffage électrique (fonction réglable par le régulateur)
E13*	2. Kälteerzeuger	Chiller 2	2. générateur de froid
F2	Lastsicherung für N1-Relaisausgänge an J13 4,0 ATr	Load fuse for N1 relay outputs at J13 4.0 slow-acting	Coupe-circuit de la charge pour sorties de relais N1 sur J13 4,0 ATr
F3	Lastsicherung für Relaisausgänge an J15 bis J18 am N1 und J12 am N2 4,0 ATr	Load fuse relay outputs at J15 to J18 at N1 and J12 at N2 4.0 slow-acting	Coupe-circuit de charge pour sorties de relais en J15 jusqu'à J18 pour N1 et en J12 pour N2 4,0 ATr
F4	Pressostat Hochdruck	High-pressure switch	Pressostat haute pression
F5	Pressostat Niederdruck	Low-pressure switch	Pressostat basse pression
F7	Heißgasthermostat	Hot gas thermostat	Thermostat gaz de chauffage
F23	Thermokontakt Ventilator	Bimetal contact, fan	Thermocontact ventilateur
H5*	Leuchte Störferrnanzeige	Remote fault indicator lamp	Témoin de télédétection de pannes
J1...J18	Klemmensteckverbinder an N1 (Heizregler)	Terminal connector at N1 (Heating controller)	Connecteur à bornes sur N1 (Régulateur de chauffage)
J1...J15	Klemmensteckverbinder an N2 (Kühlregler)	Terminal connector at N2 (cooling controller)	Connecteur à bornes sur N2 (régulateur refroidissement)
K2	Relais Ventilator M2	Ventilator relay M2	Relais ventilateur M2
K20*	Schütz für E10	Contacteur for E10	Contacteur pour E10
K21*	Schütz für E9	Contacteur for E9	Contacteur pour E9
K22*	EVU Sperrschütz	Utility blocking contactor	Contacteur de coupure de la société d'électricité
K23*	SPR Hilfsrelais	SPR auxiliary relay	Relais auxiliaire « SPR »
K25	Startrelais Verdichter M1	Starting relay compressor M1	Relais départ compresseur M1
K28*	Anforderung Kühlbetrieb	Cooling operation request	Demande mode rafraîchissement
M1	Verdichter	Compressor	Compresseur
M2	Ventilator	Ventilator	Ventilateur
M13*	Heizungsumwälzpumpe Hauptkreis	Heat circulating pump of the main circuit	Circulateur de chauffage circuit principal
M14*	Heizungsumwälzpumpe 1. Heizkreis	Heat circulating pump of heating circuit 1	Circulateur de chauffage 1er circuit de chauffage
M15*	Heizungsumwälzpumpe 2. Heizkreis	Heat circulating pump for heating circuit 2	Circulateur de chauffage 2e circuit de chauffage
M16*	Zusatzumwälzpumpe	Auxiliary circulating pump	Circulateur supplémentaire
M18*	Warmwasserumwälzpumpe	Hot water circulating pump	Circulateur d'eau chaude
M19*	Schwimmbadwasserumwälzpumpe	Swimming pool water circulating pump	Circulateur d'eau de piscine
M21*	Mischer Hauptkreis	Mixer for main circuit	Mélangeur circuit principal
M22*	Mischer 2. Heizkreis	Mixer for heating circuit 2	Mélangeur 2e circuit de chauffage
N1	Heizregler	Heating controller	Régulateur de chauffage
N2	Kühlregler	Cooling controller	Régulateur refroidissement
N3/N4*	Raumstationen für die Taupunktregelung	Room stations for dew point regulation	Stations de pièce pour régulation du point de condensation
N5*	Taupunktwärter	Dew point monitor	Contrôleur du point de condensation
N7	Sanftanlaufsteuerung	Soft start control	Commande de démarrage progressif
N9*	Raumthermostat	Room thermostat	Thermostat de pièce
N14	Bedienteil	Operating element	Commande
R1*	Außentemperaturfühler	External temperature sensor	Sonde de température extérieure
R2	Rücklauffühler	Return flow sensor	Sonde retour
R3*	Warmwasserfühler (alternativ zum Warmwasserthermostat)	Hot water sensor (as an alternative to the hot water thermostat)	Sonde d'eau chaude (alternative au thermostat eau chaude)
R5*	Fühler für den 2ten Heizkreislauf	Sensor for heating circuit 2	Sonde pour le 2e circuit de chauffage
R7	Kodierwiderstand 28k7	Coding resistor 28.7 kOhm	Résistance de codage 28k7
R8	Frostschuttfühler Kühlen	Flow sensor, cooling	Sonde antigel refroidissement
R9	Frostschuttfühler Heizen	Flow sensor, heating	Sonde antigel chauffage
R10.1*- R10.5*	Feuchtesensor für N5 (maximal 5 Sensoren)	Humidity sensor for N5 (max. of 5 sensors)	Capteur d'humidité pour N5 (5 capteurs au maximum)
T1	Sicherheitstrenntransformator 230/24 VAC-50VA	Safety isolating transformer 230/24 V AC-50VA	Transformateur sectionneur de sécurité 230/24 VAC-50VA
X1	Klemmenleiste: Einspeisung Last 3L/N/PE 400VAC~50Hz	Terminal strip: load infeed 3L/N/PE 400VAC~50Hz	Bornier : alimentation puissance 3L/N/PE 400VAC~50Hz
X2	Klemmenleiste: Einspeisung Steuerspannung L/N/PE 230 V-50Hz	Terminal strip: control voltage infeed L/N/PE 230 V-50Hz	Bornier : bornier tension de commande L/N/PE 230 V-50Hz
X3	Klemmenleiste: Kleinspannung	Terminal strip: extra-low voltage	Bornier : tension de sécurité
X4	Klemmenleiste Verdichter	Terminal strip for compressor	Bornier compresseur
Y1	Vier-Wege-Umschaltventil	Four-way valve	Vanne d'inversion 4 voies
	Abkürzungen:	Abbreviations:	Abbréviations :
EVS	EVU-Sperringang	Utility disable contactor	Entrée de coupure fournisseur d'énergie
SPR	Sperre	Block	Blocage
MA	Mischer AUF	Mixer OPEN	Mélangeur OUVERT
MZ	Mischer ZU	Mixer CLOSED	Mélangeur FERME
*	Bauteile sind extern beizustellen	Components to be supplied from external sources	Pièces à fournir par le client
- - - -	bauseits bei Bedarf anzuschließen	To be connected by the customer as required	à raccorder par le client au besoin
—	werkseitig verdrahtet	Wired ready for use	câblé départ usine

4 Hydraulische Prinzipschemen / Hydraulic Plumbing Diagrams / Schémas hydrauliques

4.1 Darstellung / Schematic View / Représentation



4.2 Legende / Legend / Légende

	Absperrventil	Shutoff valve	Robinet d'arrêt
	Überstromventil	Overflow valve	Vanne de trop-plein
	Sicherheitsventilkombination	Safety valve combination	Groupe de valves de sécurité
	Umwälzpumpe	Circulating pump	Circulateur
	Ausdehnungsgefäß	Expansion vessel	Vase d'expansion
	Raumtemperaturgesteuertes Ventil	Room temperature-controlled valve	Valve commandée par température
	Absperrventil mit Rückschlagventil	Shutoff valve with check valve	Robinet d'arrêt avec clapet anti-retour
	Absperrventil mit Entwässerung	Shutoff valve with drainage	Robinet d'arrêt avec écoulement
	Wärmeverbraucher	Heat consumer	Consommateur de chaleur
	Dreiwegemischer	Three-way mixer	Mélangeur 3 voies
	Temperaturfühler	Temperature sensor	Sonde de température
	Flexibler Anschluss Schlauch	Flexible connection hose	Tuyau de raccord flexible
①	Wärmepumpe	Heat pump	Pompe à chaleur
②	Pufferspeicher	Buffer tank	Réservoir tampon
③	Warmwasserspeicher	Hot water cylinder	Ballon d'eau chaude
④	Elektroverteilung	Electrical distribution system	Distributeur courant électrique
E9	Tauchheizkörper Warmwasser	Immersion heater hot water	Thermoplongeur eau chaude
E10	2ter Wärmeerzeuger	2nd heat generator	2e générateur de chaleur
M13	Heizungsumwälzpumpe	Heat circulating pump	Circulateur de chauffage
M14	Umwälzpumpe für Heiz- und Kühlbetrieb (elektronisch geregelt)	Circulating pump for heating and cooling operation (electronically regulated)	Circulateur pour mode chauffage et refroidissement (à régulation électronique)
M15	Heizungspumpe 2ter Heizkreis (elektronisch geregelt)	Heating pump for heating circuit 2 (electronically regulated)	Pompe chauffage circuit chauffage 2 (à régulation électronique)
M18	Warmwasserumwälzpumpe	Hot water circulating pump	Circulateur d'eau chaude
N1	Standardregler (mit Display)	Standard controller (with display)	Régulateur standard (avec cadran)
N2	Kühlregler (ohne Display)	Cooling controller (without display)	Régulateur de refroidissement (sans cadran)
N3/N4	Raumklimastationen	Room climate control stations	Postes de climatisation de pièce
R1	Außenwandfühler	External wall sensor	Sonde de paroi extérieure
R2	Rücklauffühler (integriert)	Return flow sensor (integral)	Sonde de retour (intégrée)
R3	Warmwasserfühler	Hot water sensor	Sonde d'eau chaude
R5	Rücklauffühler 2ter Heizkreis	Return flow sensor for heating circuit 2	Sonde de retour 2e circuit de chauffage
R9	Vorlauffühler	Flow sensor	Sonde aller
EV	Elektroverteilung	Electrical distribution system	Distributeur courant électrique
KW	Kaltwasser	Cold water	eau froide
MA	Mischer AUF - 2ter Heizkreis	Mixer OPEN - heating circuit 2	Mélangeur OUVERT - circuit chauffage 2
MZ	Mischer ZU - 2ter Heizkreis	Mixer CLOSED - heating circuit 2	Mélangeur FERME - circuit chauffage 2
WW	Warmwasser	Domestic hot water	Eau chaude

5 Konformitätserklärung / Declaration of Conformity / Déclaration de conformité

EG - Konformitätserklärung EC Declaration of Conformity Déclaration de conformité CE

Der Unterzeichnete
The undersigned
La société soussignée,

Glen Dimplex Deutschland GmbH
Geschäftsbereich Dimplex
Am Goldenen Feld 18
D - 95326 Kulmbach

bestätigt, dass das (die) nachfolgend be-
zeichnete(n) Gerät(e) aufgrund seiner (ihrer)
Konzipierung und Bauart sowie in der von
uns in Verkehr gebrachten Ausführung den
entschlagigen grundlegenden Anforderungen
der EG-Richtlinien entspricht (entsprechen).

Bei einer nicht mit uns abgestimmten
Änderung des (der) Gerät(e)s verliert
diese Erklärung ihre Gültigkeit.

hereby confirm that the design and con-
struction of the product(s) listed below,
in the version(s) placed on the market by
us, conform to the relevant requirements
of the applicable EC directives.

This declaration becomes invalidated
if any modifications are made to
the product(s) without our prior
authorisation.

certifie que l'appareil / les appareils ci-
après, par leur conception et leur mode de
construction ainsi que par la définition
technique avec laquelle il(s) sont mis en
circulation par notre société, est / sont
conforme(s) aux directives fondamentales
CEE afférentes.

Ce certificat perd sa validité pour tout
appareil modifié sans notre consentement.

Bezeichnung / Designation / Désignation

Luft/Wasser-Wärmepumpen
für Innenaufstellung mit R404A

Air-to-water heat pumps
for indoor installation, containing R404A

Pompes à chaleur air/eau
pour installation intérieure avec R404A

EG - Richtlinien / EC Directives / Directives CEE

EG- Niederspannungsrichtlinie / EC Low Voltage Directive /
Directive CEE relative à la basse tension (2006/95/EG)

EG-EMV-Richtlinie / EC EMC Directive / Directive CEE
relative à la compatibilité électromagnétique (89/336/EWG)

Druckgeräterichtlinie / Pressure Equipment Directive /
Directive CEE relative aux appareils sous pression (97/23/EG)

Typ(e):

Harmonisierte EN / Harmonized EB Standards / Normes EN harmonisées:

LI 11MER

EN 255:1997
EN 378:2000
DIN 8901

DIN EN 60335-1 (VDE 0700 T1):2006

DIN EN 60335-2-40 (VDE 0700 T40):2006-11

DIN EN 55014-1 (VDE 0875 T14-1):2003-09

DIN EN 55014-2 (VDE 0875 T14-2):2002-08

DIN EN 61000-3-2 (VDE 0838 T2):2005-09

DIN EN 61000-3-3 (VDE 0838 T3):2002-05

EN 60335-1:2002+A11+A1+A12+
Corr.+A2:2006

EN 60335-2-40:2003+A11+A12+A1+Corr.:2006

EN 55014-1:2000+A1:2001+A2:2002

EN 55014-2:1997+A1:2001

EN 61000-3-2:2000+A2:2005

EN 61000-3-3:1995+Corr.:1997+A1:2001

Nationale Richtlinien / National Directives / Directives nationales

D
BGR 500

A

CH
SVTI

Kulmbach, 09.02.2007

CE02W01J.doc

Wolfgang Weinhold
Geschäftsführer / Managing Director

Andreas Tifch
Spartenleiter / Head of business unit

Glen Dimplex Deutschland GmbH
Geschäftsbereich Dimplex
Am Goldenen Feld 18
D-95326 Kulmbach

Irrtümer und Änderungen vorbehalten.
Subject to alterations and errors.
Sous réserve d'erreurs et modifications.
 +49 (0) 9221 709 565
www.dimplex.de

Free Manuals Download Website

<http://myh66.com>

<http://usermanuals.us>

<http://www.somanuals.com>

<http://www.4manuals.cc>

<http://www.manual-lib.com>

<http://www.404manual.com>

<http://www.luxmanual.com>

<http://aubethermostatmanual.com>

Golf course search by state

<http://golfingnear.com>

Email search by domain

<http://emailbydomain.com>

Auto manuals search

<http://auto.somanuals.com>

TV manuals search

<http://tv.somanuals.com>