

***LI 20TEL***  
***LI 24TEL***  
***LI 28TEL***

**Dimplex**

**Montage- und  
Gebrauchsanweisung**

Deutsch

**Installation and  
Operating Instructions**

English

**Instructions d'installation  
et d'utilisation**

Français

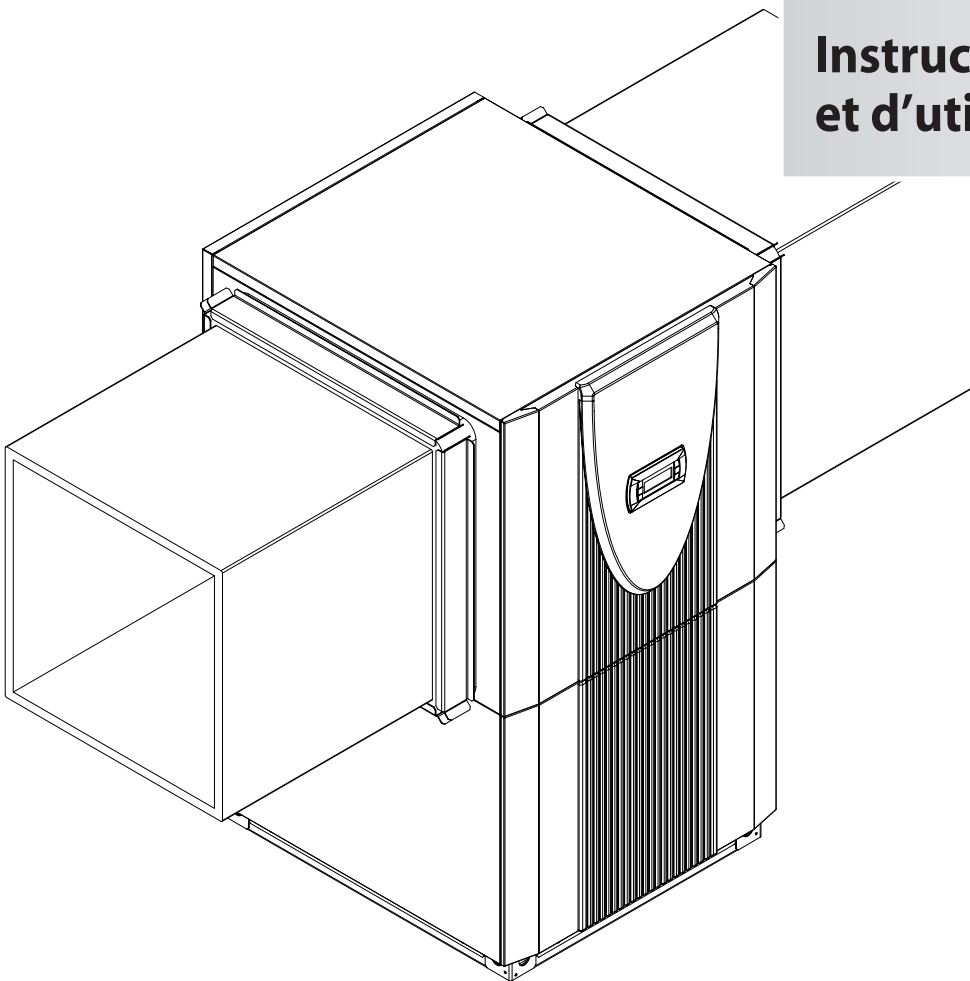

**Luft/Wasser-  
Wärmepumpe für  
Innenaufstellung**

**Air-to-Water  
Heat Pump for  
Indoor Installation**

**Pompe à chaleur  
air-eau pour  
installation  
intérieure**

## Table of contents

<b>1</b>	<b>Please Read Immediately .....</b>	<b>E-2</b>
1.1	Important Information:.....	E-2
1.2	Legal Regulations and Directives .....	E-2
1.3	Energy-Efficient Use of the Heat Pump .....	E-2
<b>2</b>	<b>Purpose of the Heat Pump .....</b>	<b>E-3</b>
2.1	Application .....	E-3
2.2	Operating Principle .....	E-3
<b>3</b>	<b>Scope of Delivery .....</b>	<b>E-3</b>
3.1	Basic Device .....	E-3
3.2	Switch Box .....	E-4
3.3	Heat Pump Controller .....	E-4
<b>4</b>	<b>Transport.....</b>	<b>E-4</b>
<b>5</b>	<b>Set-UP .....</b>	<b>E-5</b>
5.1	General Information .....	E-5
5.2	Condensed Water Pipe.....	E-5
5.3	Sound .....	E-5
<b>6</b>	<b>Installation .....</b>	<b>E-5</b>
6.1	General Information .....	E-5
6.2	Air Connection .....	E-5
6.3	Heating System Connection .....	E-6
6.4	Electrical Connection .....	E-6
<b>7</b>	<b>Start-UP .....</b>	<b>E-7</b>
7.1	General Information .....	E-7
7.2	Preparation .....	E-7
7.3	Procedure .....	E-7
<b>8</b>	<b>Maintenance / Cleaning .....</b>	<b>E-8</b>
8.1	Maintenance .....	E-8
8.2	Cleaning the Heating System .....	E-8
8.3	Cleaning the Air System .....	E-8
<b>9</b>	<b>Faults / Trouble-Shooting.....</b>	<b>E-8</b>
<b>10</b>	<b>Decommissioning/Disposal .....</b>	<b>E-8</b>
<b>11</b>	<b>Device Information .....</b>	<b>E-9</b>
	<b>Anhang / Appendix / Annexes .....</b>	<b>A-I</b>

# 1 Please Read Immediately

## 1.1 Important Information:

### **⚠ ATTENTION!**

The device is not suitable for operation with a frequency converter.

### **⚠ ATTENTION!**

When transporting the heat pump, ensure that it is not tilted more than 45° (in any direction).

### **⚠ ATTENTION!**

The heat pump and transport pallet are only joined by the packing film.

### **⚠ ATTENTION!**

Do not restrict or block the area around the air intake or outlet.

### **⚠ ATTENTION!**

Only operate the heat pump with the air ducts connected.

### **⚠ ATTENTION!**

Ensure that there is a clockwise rotating field: Operating the compressor in the wrong rotational direction could cause damage to the compressor.

### **⚠ ATTENTION!**

Never use cleaning agents containing sand, soda, acid or chloride as these can damage the surfaces.

### **⚠ ATTENTION!**

We recommend the installation of a suitable corrosion protection system to prevent the formation of deposits (e.g. rust) in the condenser of the heat pump.

### **⚠ ATTENTION!**

Before opening the device, ensure that all circuits are isolated from the power supply.

### **⚠ ATTENTION!**

Any work on the heat pump may only be performed by authorised and qualified after-sales service technicians.

## 1.2 Legal Regulations and Directives

The construction and design of the heat pump complies with all relevant EU directives, DIN/VDE regulations (see CE declaration of conformity).

When connecting the heat pump to the power supply, the relevant VDE, EN and IEC standards are to be fulfilled. Any further connection requirements stipulated by local utility companies must also be observed.

When connecting the heating system, all applicable regulations must also be adhered to.

Persons, especially children, who are not capable of operating the device safely due to their physical, sensory or mental abilities or their inexperience or lack of knowledge, must not operate this device without supervision or instruction by the person in charge.

Children must be supervised to ensure that they do not play with the device.

## 1.3 Energy-Efficient Use of the Heat Pump

With the purchase of this heat pump you are helping to protect the environment. A prerequisite for energy-efficient operation is the correct design of the heat source system and heating system (radiators and circulation pump).

It is particularly important for the efficiency of a heat pump to keep the temperature difference between heating water and heat source as small as possible. For this reason, it is advisable to design the heat source and heating system very carefully. **A temperature difference of approx. one Kelvin increases the power consumption by around 2.5%.** When designing the heating system, it should be borne in mind that special consumers such as e.g. hot water preparation should also be considered and dimensioned for low temperatures. **Underfloor heating systems (panel heating)** are optimally suited for heat pump use on account of the low flow temperatures (30 °C to 40 °C).

It is important to ensure that the heat exchangers are not contaminated during operation because this increases the temperature difference, in turn reducing the COP.

Correct adjustment of the heat pump controller is also important for energy-efficient use of the heat pump. Further information can be found in the heat pump controller's operating instructions.

## 2 Purpose of the Heat Pump

### 2.1 Application

The air-to-water heat pump is designed for use in existing or newly built heating systems.

It is designed exclusively for heating domestic and heating water!

The heat pump is suitable for mono energy and bivalent operation down to an external temperature of -20 °C.

Proper defrosting of the evaporator is guaranteed by maintaining a heating water return flow temperature of more than 18 °C during continuous operation.

The heat pump is not designed for the increased heat consumption required when a building is being dried out. The additional heat consumption should be met using special devices provided by the customer. If a building is to be dried out in autumn or winter, we recommend installing an additional heating element (available as an accessory).

#### **⚠ ATTENTION!**

The device is not suitable for operation with a frequency converter.

### 2.2 Operating Principle

Outside air is drawn in by the ventilator and fed via the evaporator (heat exchanger). The evaporator cools the air, i.e. it extracts heat from it. This extracted heat is then transferred to the working medium (refrigerant) in the evaporator.

The heat is "pumped" to a higher temperature level by increasing its pressure with the aid of the electrically driven compressors. It is then transferred to the heating water using the liquifier (heat exchanger).

Electrical energy is used to raise the temperature of the heat in the environment to a higher level. Because the energy extracted from the air is transferred to the heating water, this type of device is called an air-to-water heat pump.

The air-to-water heat pump consists of the main components evaporator, ventilator and expansion valve, as well as the low-noise compressors, liquifier and electrical control system.

At low ambient temperatures, humidity accumulates on the evaporator in the form of frost reducing the transfer of heat. The evaporator is defrosted automatically by the heat pump as required. Steam may be emitted from the air outlet depending on the atmospheric conditions.

## 3 Scope of Delivery

### 3.1 Basic Device

The heat pump is of compact design and is supplied complete with the components listed below.

R404A is used as the refrigerant.

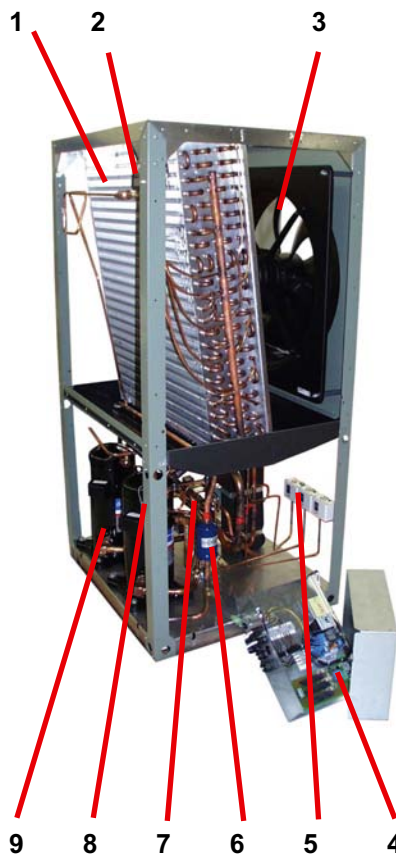

- 1) Evaporator
- 2) Check valve
- 3) Ventilator
- 4) Switch box
- 5) Controllers
- 6) Filter dryer
- 7) Liquifier
- 8) Expansion valve
- 9) Compressor

## 3.2 Switch Box

The switch box is located in the heat pump. It can be swung out after removing the lower front cover and loosening the fastening screw located in the upper right-hand corner.

The switch box contains the supply connection terminals, as well as the power contactors, the soft starter unit and the heat pump manager.

## 3.3 Heat Pump Controller

The heat pump manager is a convenient electronic regulation and control device. It controls and monitors the entire heating system on the basis of the external temperature, including hot water preparation and safety systems.

The customer must install the external temperature sensor, which is included in the scope of supply of the heat pump controller together with the necessary fixing accessories.

The enclosed operating instructions describe the function and use of the heat pump manager.

## 4 Transport

### **⚠ ATTENTION!**

When transporting the heat pump, ensure that it is not tilted more than 45° (in any direction).

Use a wooden pallet for transporting the heat pump to the final installation location. The basic device can be transported with a lift truck, hand truck or by means of 3/4" pipes fed through the holes in the base plate or frame.

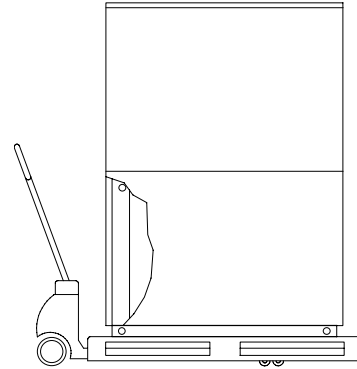

### **⚠ ATTENTION!**

The heat pump and transport pallet are only joined by the packing film.

Before using the transport holes in the frame, it is necessary to remove the lower side panel assemblies. This is done by loosening each of the two screws at the base and then withdrawing the panels by unhooking them from above. Rehang the panels by gently pushing them in an upwards direction.

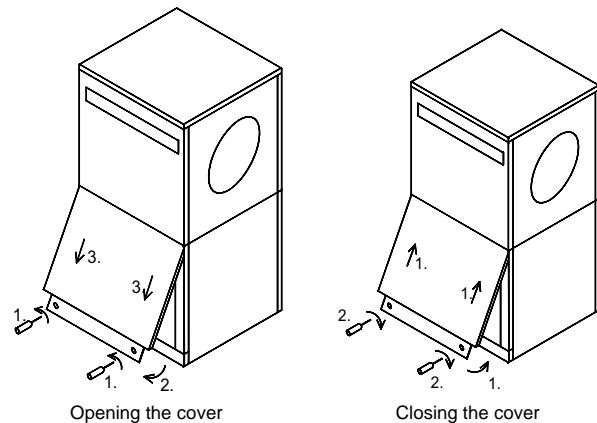

Be careful not to damage any components when inserting the pipes through the frame.

## 5 Set-UP

### 5.1 General Information

The unit must be installed indoors on a level, smooth and horizontal surface. The entire base of the frame should lie directly on the floor to ensure a good soundproof seal. If this is not the case, additional sound insulation measures may be necessary. If the device is installed on top of a built-under buffer tank, a surface that fully supports the base is required. The heat pump must be installed so that maintenance work can be carried out without being hindered. This can be ensured by maintaining a clearance of 1 m in front and to the left and right of the heat pump.

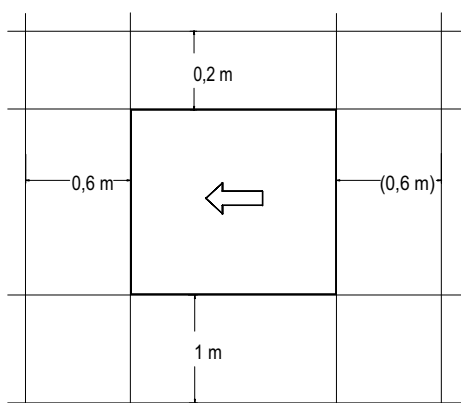

Never install the device in rooms subject to high humidity. Condensation can form on the heat pump and air circuit if the humidity exceeds 50% and the external temperature is below 0 °C.

If the heat pump is installed on an upper storey, the load-bearing capacity of the ceiling should be checked. On account of the acoustics, measures for isolating possible vibrations should also be very carefully planned in advance as well. Installation on a wooden floor is not recommended.

### 5.2 Condensed Water Pipe

Condensed water that forms during operation must be drained off frost-free. The heat pump must be mounted on a level plane to guarantee proper drainage. The condensed water pipe must have a minimum diameter of 50 mm and should be fed frost-free into a sewer. Condensate should not be discharged directly into clearing tanks and cesspits because the aggressive vapours could destroy the evaporator.

### 5.3 Sound

To prevent solid-borne sound from being transmitted to the heating system, we recommend connecting the heat pump to the heating system using a flexible hose.

Installed air ducts should be sound-isolated from the heat pump to prevent the transmission of solid-borne sound to the ducts.

## 6 Installation

### 6.1 General Information

The following connections need to be established on the heat pump:

- Fresh and exhaust air
- Flow and return flow of the heating system
- Condensate outflow
- Power supply

### 6.2 Air Connection

#### **⚠ ATTENTION!**

Do not restrict or block the area around the air intake or outlet.

#### **⚠ ATTENTION!**

Only operate the heat pump with the air ducts connected.

The glass fibre reinforced concrete air ducts offered as accessories are moisture-resistant and diffusion-free.

The sealing collar is used to seal the air ducts on the heat pump. The air ducts are not screwed directly onto the heat pump. Only the rubber seal comes into direct contact with the heat pump when the system is installed correctly. This guarantees easy assembly and disassembly of the heat pump and also ensures that solid-borne sound is well insulated.

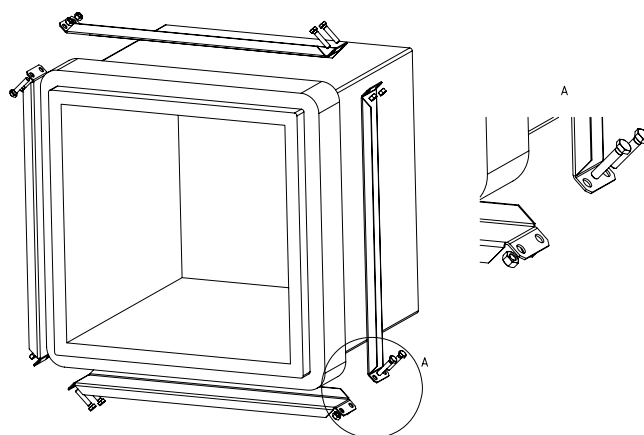

If another type of air duct is used, observe the external and internal dimensions as specified in the figure. Also ensure that the vibration and duct insulation are adequate.

If flange-mounted air ducts are used, connecting stubs are secured on the air inlet and air outlet sides of the evaporator with 4 M8 x 16 hexagon bolts in the threaded holes provided. When doing this, ensure that both air duct stubs only touch the insulation. There should be no contact with the external sheeting.

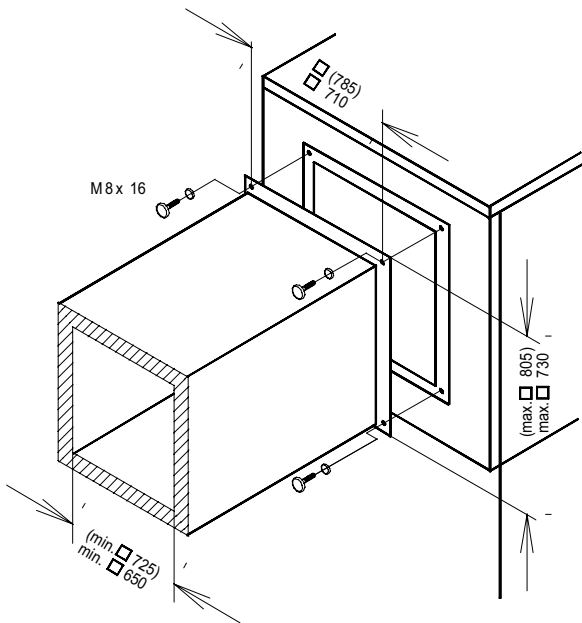

The values in parentheses are valid for the LI 24TEL/ LI 28TEL

## 6.3 Heating System Connection

The heating system connections on the heat pump have a 1 1/4" external thread. Use a spanner to firmly grip the transitions when connecting the heat pump.

Before connecting the heating water system to the heat pump, the heating system must be flushed to remove any impurities, residue from sealants, etc. Any accumulation of deposits in the liquifier could cause the heat pump to completely break down. For systems in which the heating water flow can be shut off via the radiator or thermostat valves, an overflow valve must be installed in a heating bypass behind the heat pump by the customer. This ensures a minimum heating water flow rate through the heat pump and helps to avoid faults.

Once the heating system has been installed, it must be filled, de-aerated and pressure-tested.

### Minimum heating water flow rate

The minimum heating water flow rate through the heat pump must be assured in all operating states of the heating system. This can be accomplished, for example, by installing either a manifold without differential pressure or an overflow valve. The procedure for adjusting an overflow valve is described in the Chapter Start-Up.

## Antifreeze

A method of manual drainage (see illustration) should be provided for heat pumps which are exposed to frost. The antifreeze function of the heat pump controller is active whenever the controller and the heat circulating pump are ready for operation. If the heat pump is taken out of service or in the event of a power failure, the system has to be drained. The heating circuit should be operated with a suitable antifreeze if heat pump systems are implemented in buildings where a power failure can not be detected (holiday home).

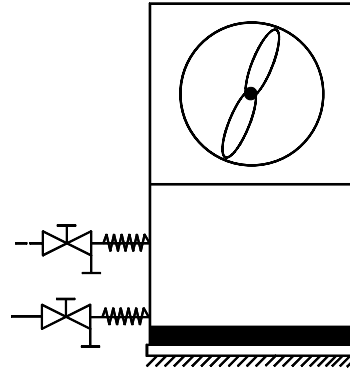

## 6.4 Electrical Connection

The power supply and control voltage are supplied using standard cables (load: 4-core, control: 3-core).

For detailed instructions on how to connect the external components and how the heat pump controller functions, please refer to the device connection diagram and the operating manual supplied with the controller.

An all-pole disconnecting device with a contact gap of at least 3 mm (e.g. utility blocking contactor or power contactor) as well as a 3-pole circuit breaker with common tripping for all external conductors must be installed in the power supply (tripping current in compliance with the Device Information).

Ensure that the incoming supply has a clockwise rotating field when connecting multiphase devices L1; L2; L3.

### **⚠ ATTENTION!**

Ensure that there is a clockwise rotating field: Operating the compressor in the wrong rotational direction could cause damage to the compressor.

The control voltage must be protected by a 10 A fuse.

For detailed information, see Circuit Diagrams in the Appendix.

## 7 Start-UP

### 7.1 General Information

To ensure that start-up is performed correctly, it should only be carried out by an after-sales service technician authorised by the manufacturer. This may be a condition for extending the guarantee (see Warranty Service).

### 7.2 Preparation

The following items need to be checked prior to start-up:

- All of the heat pump connections must be established as described in Chapter 6.
- All valves that could impair the proper flow of the heating water in the heating circuit must be open.
- The air intake and air outlet paths must be clear.
- The ventilator must turn in the direction indicated by the arrow.
- The settings of the heat pump controller must be adapted to the heating system in accordance with the controller's operating instructions.
- Ensure the condensate outflow functions.

### 7.3 Procedure

The heat pump is started up via the heat pump controller. Adjustments should be made in compliance with the instructions.

If an overflow valve is fitted to maintain the minimum heating water flow rate, the valve must be adapted to the requirements of the heating system. Incorrect adjustment can lead to faulty operation and increased energy consumption. We recommend carrying out the following procedure to correctly adjust the overflow valve:

Close all of the heating circuits that may also be closed during operation (depending on the type of heat pump usage) so that the most unfavourable operating state - with respect to the water flow rate - is achieved. This normally means the heating circuits of the rooms on the south and west sides of the building. At least one heating circuit must remain open (e.g. bathroom).

The overflow valve should be opened far enough to produce the maximum temperature spread between the heating flow and return flow listed in the following table for the current heat source temperature. The temperature spread should be measured as close as possible to the heat pump. The heating element of mono energy systems should be disconnected.

Heat source temperature		Max. temperature spread between heating flow and return flow
From	To	
-20 °C	-15 °C	4 K
-14 °C	-10 °C	5 K
-9 °C	-5 °C	6 K
-4 °C	0 °C	7 K
1 °C	5 °C	8 K
6 °C	10 °C	9 K
11 °C	15 °C	10 K
16 °C	20 °C	11 K
21 °C	25 °C	12 K
26 °C	30 °C	13 K
31 °C	35 °C	14 K

Any faults occurring during operation are also displayed on the heat pump controller and can be corrected as described in the operating instructions of the heat pump controller.

For external temperatures below 10 °C and heating water temperatures below 16 °C, the buffer tank should be heated up with the 2nd heat generator to at least 25 °C.

Observe the following procedure to implement a smooth start-up:

- 1) Close all of the heating circuits.
- 2) Fully open the overflow valve.
- 3) Use the controller to select the automatic operating mode.
- 4) Wait until the buffer tank has reached a temperature of at least 25 °C.
- 5) Now slowly reopen the heating circuit valves in succession so that the heating water throughput is constantly raised by slightly opening the respective heating circuit. The heating water temperature in the buffer tank must not be allowed to drop below 20 °C during this process. This ensures that the heat pump can be de-frosted at any time.
- 6) Set the minimum volume flow quantity on the overflow valve and heat circulating pump when all heating circuits are fully open and a heating water temperature in the buffer tank of approx. 20 °C is maintained.
- 7) New buildings have an increased heat consumption on account of the energy required to dry them out. This increased heat consumption means that marginally dimensioned heating systems can not always achieve the desired room temperature. In such cases, we recommend keeping a 2nd heat generator on standby during the first heating period. The limit temperature on the heat pump controller should also be turned up to 15 °C.



## 8 Maintenance / Cleaning

### 8.1 Maintenance

To protect the paintwork, avoid leaning or putting objects on the device. External heat pump parts can be wiped with a damp cloth and domestic cleaner.

#### **⚠ ATTENTION!**

Never use cleaning agents containing sand, soda, acid or chloride as these can damage the surfaces.

To prevent faults due to sediment in the heat exchanger of the heat pump, ensure that the heat exchanger in the heating system can not be contaminated. We recommend protecting the evaporator by installing a bird guard in the inlet duct. At least 80% of the cross section of the grating should be open. In the event that operating malfunctions due to contamination still occur, the system should be cleaned as described below.

### 8.2 Cleaning the Heating System

The ingress of oxygen into the heating water circuit may result in the formation of oxidation products (rust), particularly if steel components are used. These products enter the heating system via the valves, the circulating pumps and/or plastic pipes. It is therefore essential - in particular with respect to the piping of underfloor heating systems - that only diffusion-proof materials are used.

#### **⚠ ATTENTION!**

We recommend the installation of a suitable corrosion protection system to prevent the formation of deposits (e.g. rust) in the condenser of the heat pump.

Residue from lubricants and sealants may also contaminate the heating water.

In the case of severe contamination leading to a reduction in the performance of the liquifier in the heat pump, the system must be cleaned by a heating technician.

According to today's state of knowledge, we recommend using a 5 % phosphoric acid solution for cleaning purposes. However, if cleaning needs to be performed more frequently, a 5 % formic acid solution should be used.

In either case, the cleaning fluid should be at room temperature. We recommend flushing the heat exchanger in the direction opposite to the normal flow direction.

To prevent acidic cleaning agents from entering the heating system circuit, we recommend connecting the flushing device directly to the flow and return flow of the liquifier of the heat pump.

It is important that the system be thoroughly flushed using appropriate neutralising agents to prevent any damage from being caused by cleaning agent residue remaining in the system.

Acids must be used with great care and all relevant regulations of the employers' liability insurance associations must be adhered to.

If in doubt, contact the manufacturer of the chemicals!

### 8.3 Cleaning the Air System

Air ducts, evaporator, ventilator and condensate outflow should be cleaned of contamination (leaves, twigs, etc.) before the heating period. Do this by opening the front of the heat pump. The bottom should be opened first followed by the top.

#### **⚠ ATTENTION!**

Before opening the device, ensure that all circuits are isolated from the power supply.

Remove and rehang the side panel assemblies as described in Chapter 4.

To prevent the evaporator and the condensate tray from being damaged, do not use hard or sharp objects for cleaning.

## 9 Faults / Trouble-Shooting

This heat pump is a quality product and is designed for trouble-free and maintenance-free operation. In the event that a fault should occur, it will be shown on the heat pump manager display. Simply consult the Faults and Trouble-shooting page in the operating instructions of the heat pump manager. If you cannot correct the fault yourself, please contact your after-sales service technician.

#### **⚠ ATTENTION!**

Any work on the heat pump may only be performed by authorised and qualified after-sales service technicians.

## 10 Decommissioning/ Disposal

Before removing the heat pump, disconnect it from the power source and close all valves. Observe all environmentally-relevant requirements regarding the recovery, recycling and disposal of materials and components in accordance with all applicable standards. Particular attention should be paid to the proper disposal of refrigerants and refrigeration oils.

# 11 Device Information

Device information for air-to-water heat pumps (heating only) LI 20TEL - LI 24TEL				
<b>1</b>	<b>Type and order code</b>		LI 20TEL	LI 24TEL
<b>2</b>	<b>Design</b>			
<b>2.1</b>	<b>Degree of protection according to EN 60 529 for compact devices and heating components</b>		IP 21	IP 21
<b>2.2</b>	<b>Installation location</b>		Indoors	Indoors
<b>3</b>	<b>Performance data</b>			
<b>3.1</b>	<b>Operating temperature limits:</b>			
	Heating water flow/return flow <sup>1</sup>	°C / °C	Up to 58 / above 18	
	Air	°C	-25 to +35	
<b>3.2</b>	<b>Temperature spread of heating water (flow/return flow) at A7 / W35K</b>		9.8	5.0
<b>3.3</b>	<b>Heat output / COP</b>	at A-7 / W35 <sup>2</sup>	7.1 / 2.8	6.7 / 2.6
			12.7 / 2.8	11.7 / 2.6
		at A-7 / W45 <sup>2</sup>		6.2 / 2.3
				11.1 / 2.2
		at A2 / W35 <sup>2</sup>	9.3 / 3.2	8.6 / 3.1
			14.9 / 3.1	14.6 / 3.0
		at A7 / W35 <sup>2</sup>	10.7 / 3.7	10.4 / 3.5
			17.1 / 3.5	17.0 / 3.4
		at A7 / W45 <sup>2</sup>		10.1 / 3.0
				16.6 / 2.9
		at A10 / W35 <sup>2</sup>	12.8 / 4.0	12.6 / 3.8
			20.0 / 3.8	19.5 / 3.7
<b>3.4</b>	<b>Sound power level device / outdoors</b>	dB(A)	58 / 64	
<b>3.5</b>	<b>Sound pressure level at a distance of 1 m (indoors)</b>	dB(A)	54	
<b>3.6</b>	<b>Heating water flow with an internal pressure differential of m<sup>3</sup>/h / Pa</b>		1.8 / 3700	3.3 / 12300
<b>3.7</b>	<b>Air flow rate with an external static pressure differential of m<sup>3</sup>/h / Pa</b>		6600 / 0	
		m <sup>3</sup> /h / Pa	5500 / 25	
<b>3.8</b>	<b>Refrigerant; total filling weight</b>	type / kg	R404A / 3.7	
<b>4</b>	<b>Dimensions, connections and weight</b>			
<b>4.1</b>	<b>Device dimensions</b>	H x W x L cm	157 x 75 x 88	
<b>4.2</b>	<b>Device connections to heating system</b>	Inch	G 1 1/4" external	
<b>4.3</b>	<b>Air duct inlet and outlet (min. internal dimensions)</b>	L x W cm	65 x 65	
<b>4.4</b>	<b>Weight of the transportable unit(s) incl. packing</b>	kg	255	
<b>5</b>	<b>Electrical Connection</b>			
<b>5.1</b>	<b>Nominal voltage; fuse protection</b>	V / A	400 / 20 T	
<b>5.2</b>	<b>Nominal power consumption <sup>2</sup> A2 W35</b>	kW	4.80	4.89
<b>5.3</b>	<b>Starting current with soft starter</b>	A	23	
<b>5.4</b>	<b>Nominal current A2 W35 / cosφ</b>	A / ---	8.7 / 0.8	8.8 / 0.8
<b>6</b>	<b>Complies with the European safety regulations</b>		5	
<b>7</b>	<b>Additional model features</b>			
<b>7.1</b>	<b>Defrosting</b>		Automatic	Automatic
	Type of defrosting		Reverse cycle	Reverse cycle
	Defrosting tray included		Yes (heated)	Yes (heated)
<b>7.2</b>	<b>Heating water in device protected against icing <sup>6</sup></b>		Yes	Yes
<b>7.3</b>	<b>Performance levels</b>		2	
<b>7.4</b>	<b>Controller internal/external</b>		Internal	Internal

1. See operating limits diagram

2. This data indicates the size and capacity of the system. For an analysis of the economic and energy efficiency of the system, other parameters, such as, in particular, the defrosting capacity, the bivalence point and regulation, should also be taken into consideration. The specified values, e.g. A2 / W55, have the following meaning: 2 °C external air temperature and 55 °C heating water flow temperature.

3. Operation with 1 compressors

4. Operation with 2 compressors

5. See CE declaration of conformity

6. The heat circulating pump and the heat pump controller must always be ready for operation.

## Device information for air-to-water heat pumps (heating only) LI 28TEL

Device information for air-to-water heat pumps (heating only) LI 28TEL			
<b>1</b>	<b>Type and order code</b>		LI 28TEL
<b>2</b>	<b>Design</b>		
<b>2.1</b>	<b>Degree of protection according to EN 60 529 for compact devices and heating components</b>		IP 21
<b>2.2</b>	<b>Installation location</b>		Indoors
<b>3</b>	<b>Performance data</b>		
<b>3.1</b>	<b>Operating temperature limits:</b>		
	Heating water flow/return flow <sup>1</sup>	°C / °C	Up to 58 / above 18
	Air	°C	-25 to +35
<b>3.2</b>	<b>Temperature spread of heating water (flow/return flow) at A7 / W35K</b>		9.9   5.0
<b>3.3</b>	<b>Heat output / COP</b>		
	at A-7 / W35 <sup>2</sup>	kW / ---	9.9 / 2.4   9.2 / 2.3
			19.1 / 2.7   16.1 / 2.3
	at A-7 / W45 <sup>2</sup>	kW / ---	8.7 / 2.0
			15.0 / 1.9
	at A2 / W35 <sup>2</sup>	kW / ---	12.8 / 3.0   12.6 / 3.0
			22.3 / 3.0   22.2 / 3.0
	at A7 / W35 <sup>2</sup>	kW / ---	14.2 / 3.1   13.9 / 3.1
			25.8 / 3.4   25.1 / 3.3
	at A7 / W45 <sup>2</sup>	kW / ---	12.8 / 2.9
			24.6 / 2.8
	at A10 / W35 <sup>2</sup>	kW / ---	14.7 / 3.1   14.3 / 3.2
			29.1 / 3.6   28.7 / 3.5
<b>3.4</b>	<b>Sound power level device / outdoors</b>	dB(A)	62 / 68
<b>3.5</b>	<b>Sound pressure level at a distance of 1 m (indoors)</b>	dB(A)	58
<b>3.6</b>	<b>Heating water flow with an internal pressure differential of m<sup>3</sup>/h / Pa</b>		2.3 / 3100   4.6 / 12000
<b>3.7</b>	<b>Air flow rate with an external static pressure differential of m<sup>3</sup>/h / Pa</b>		9000 / 0
		m <sup>3</sup> /h / Pa	8000 / 25
<b>3.8</b>	<b>Refrigerant; total filling weight</b>	type / kg	R404A / 4.3
<b>4</b>	<b>Dimensions, connections and weight</b>		
<b>4.1</b>	<b>Device dimensions</b>	H x W x L cm	171 x 75 x 103
<b>4.2</b>	<b>Device connections to heating system</b>	Inch	G 1 1/4" external
<b>4.3</b>	<b>Air duct inlet and outlet (min. internal dimensions)</b>	L x W cm	72.5 x 72.5
<b>4.4</b>	<b>Weight of the transportable unit(s) incl. packing</b>	kg	314
<b>5</b>	<b>Electrical Connection</b>		
<b>5.1</b>	<b>Nominal voltage; fuse protection</b>	V / A	400 / 25 T
<b>5.2</b>	<b>Nominal power consumption <sup>2</sup> A2 W35</b>	kW	7.40   7.44
<b>5.3</b>	<b>Starting current with soft starter</b>	A	25
<b>5.4</b>	<b>Nominal current A2 W35 / cosφ</b>	A / ---	13.4 / 0.8   13.4 / 0.8
<b>6</b>	<b>Complies with the European safety regulations</b>		5
<b>7</b>	<b>Additional model features</b>		
<b>7.1</b>	<b>Defrosting</b>		Automatic
	Type of defrosting		Reverse cycle
	Defrosting tray included		Yes (heated)
<b>7.2</b>	<b>Heating water in device protected against icing <sup>6</sup></b>		Yes
<b>7.3</b>	<b>Performance levels</b>		2
<b>7.4</b>	<b>Controller internal/external</b>		Internal

1. See operating limits diagram

2. This data indicates the size and capacity of the system. For an analysis of the economic and energy efficiency of the system, other parameters, such as, in particular, the defrosting capacity, the bivalence point and regulation, should also be taken into consideration. The specified values, e.g. A2 / W55, have the following meaning: 2 °C external air temperature and 55 °C heating water flow temperature.

3. Operation with 1 compressors

4. Operation with 2 compressors

5. See CE declaration of conformity

6. The heat circulating pump and the heat pump controller must always be ready for operation.

---

## Anhang / Appendix / Annexes

<b>1</b>	<b>Maßbilder / Dimension Drawings / Schémas cotés.....</b>	<b>A-II</b>
1.1	Maßbild / Dimension Drawing / Schéma coté LI 20TEL .....	A-II
1.2	Maßbild / Dimension Drawing / Schéma coté LI 24TEL / LI 28TEL.....	A-III
<b>2</b>	<b>Diagramme / Diagrams / Diagrammes.....</b>	<b>A-IV</b>
2.1	Kennlinien / Characteristic curves / Courbes caractéristiques LI 20TEL .....	A-IV
2.2	Kennlinien / Characteristic curves / Courbes caractéristiques LI 24TEL .....	A-V
2.3	Kennlinien / Characteristic curves / Courbes caractéristiques LI 28TEL .....	A-VI
<b>3</b>	<b>Stromlaufpläne / Circuit Diagrams / Schémas électriques.....</b>	<b>A-VII</b>
3.1	Steuerung / Control / Commande .....	A-VII
3.2	Last / Load / Charge .....	A-VIII
3.3	Anschlussplan / Circuit Diagram / Schéma électrique .....	A-IX
3.4	Legende / Legend / Légende.....	A-X
<b>4</b>	<b>Hydraulische Prinzipschemen / Hydraulic Plumbing Diagrams / Schémas hydrauliques ...</b>	<b>A-XI</b>
4.1	Monoenergetische Anlage / Mono energy system / Installation mono-énergétique .....	A-XI
4.2	Monoenergetische Anlage und Warmwasserbereitung / Mono energy system and domestic hot water preparation / Installation mono-énergétique et production d'eau chaude .....	A-XII
4.3	Bivalente Anlage / Bivalent system / Installation bivalente .....	A-XIII
4.4	Legende / Legend / Légende.....	A-XIV
<b>5</b>	<b>Konformitätserklärung / Declaration of Conformity / Déclaration de conformité .....</b>	<b>A-XV</b>

# 1 Maßbilder / Dimension Drawings / Schémas cotés

## 1.1 Maßbild / Dimension Drawing / Schéma coté LI 20TEL

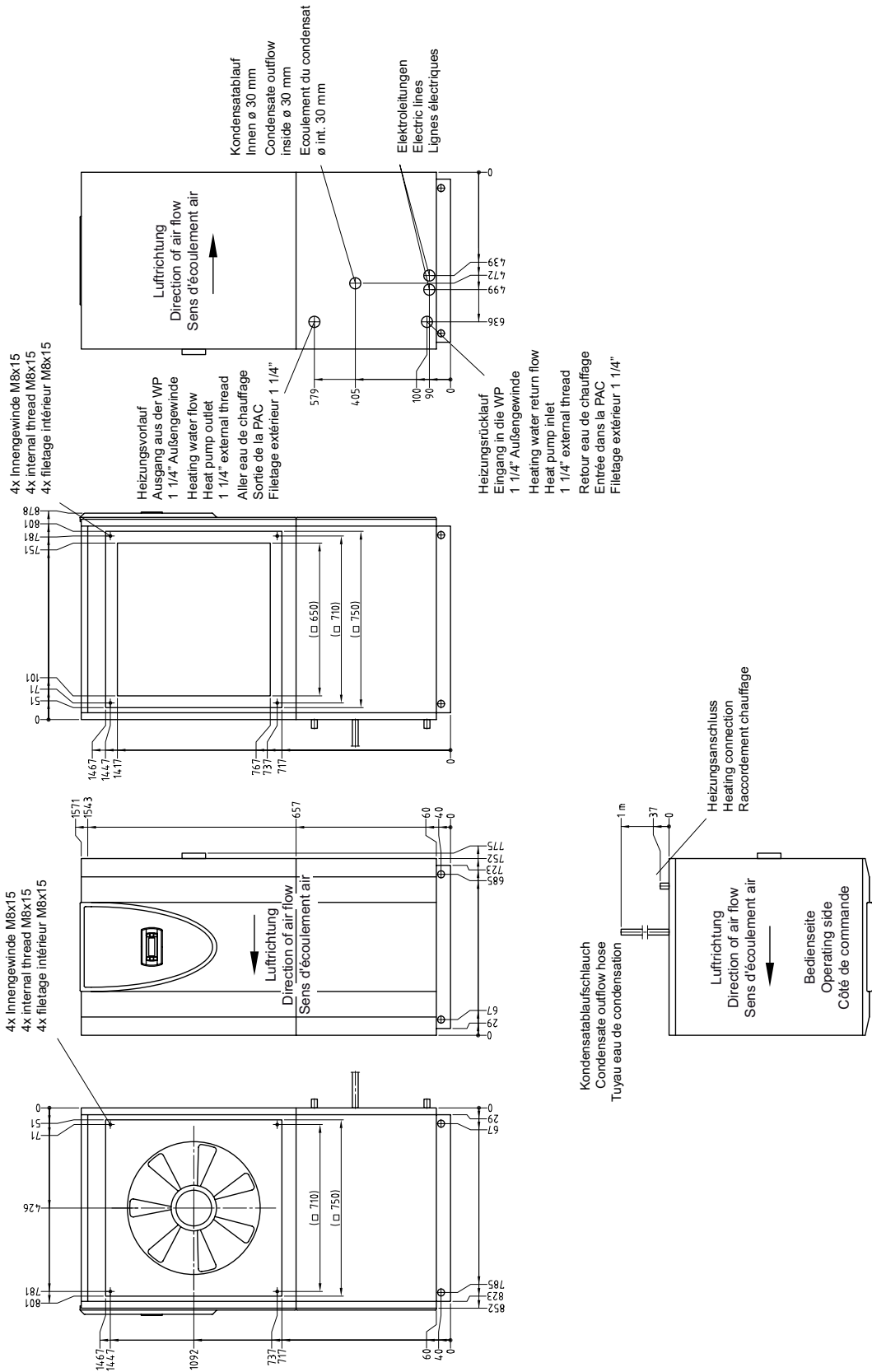

1.2 Maßbild / Dimension Drawing / Schéma coté LI 24TEL / LI 28TEL

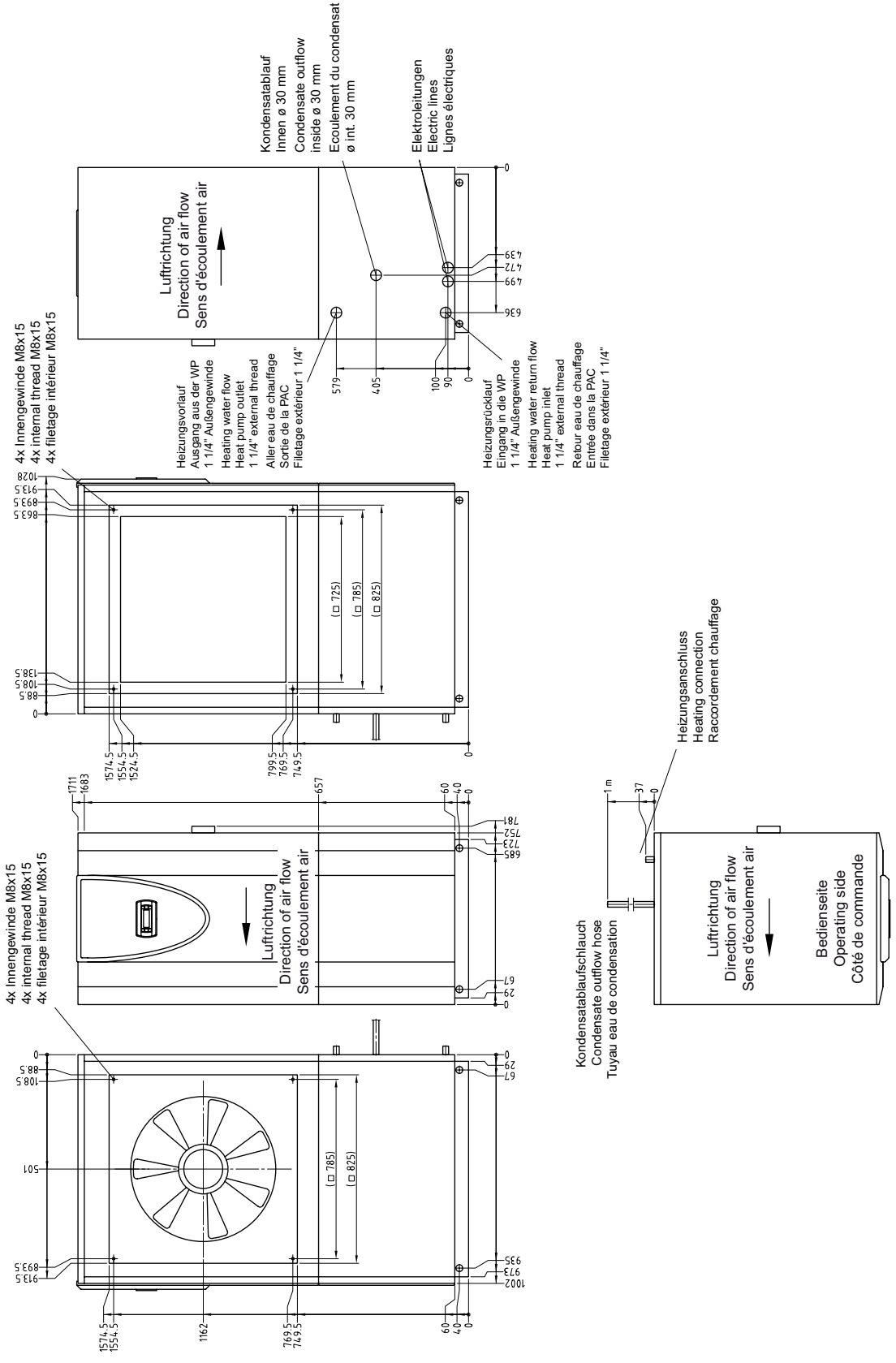

## 2 Diagramme / Diagrams / Diagrammes

### 2.1 Kennlinien / Characteristic curves / Courbes caractéristiques LI 20TEL

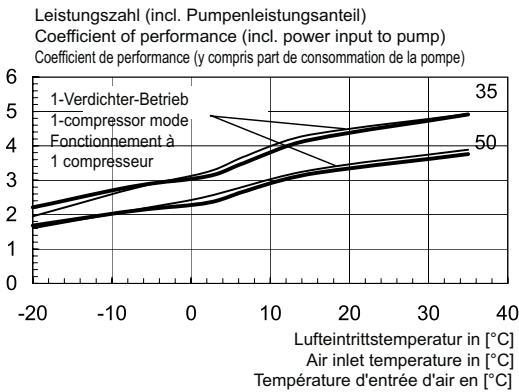
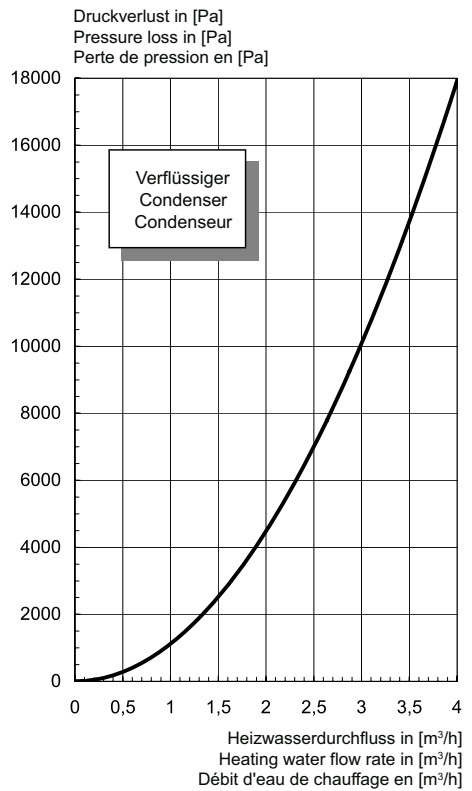
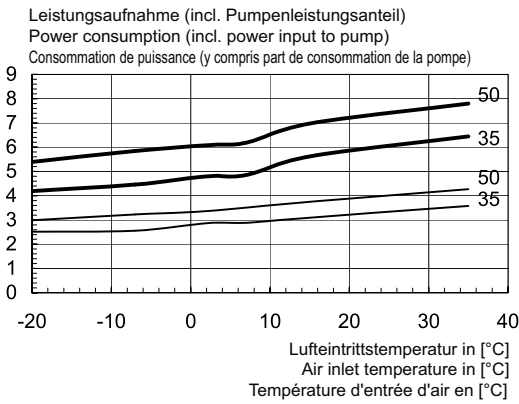
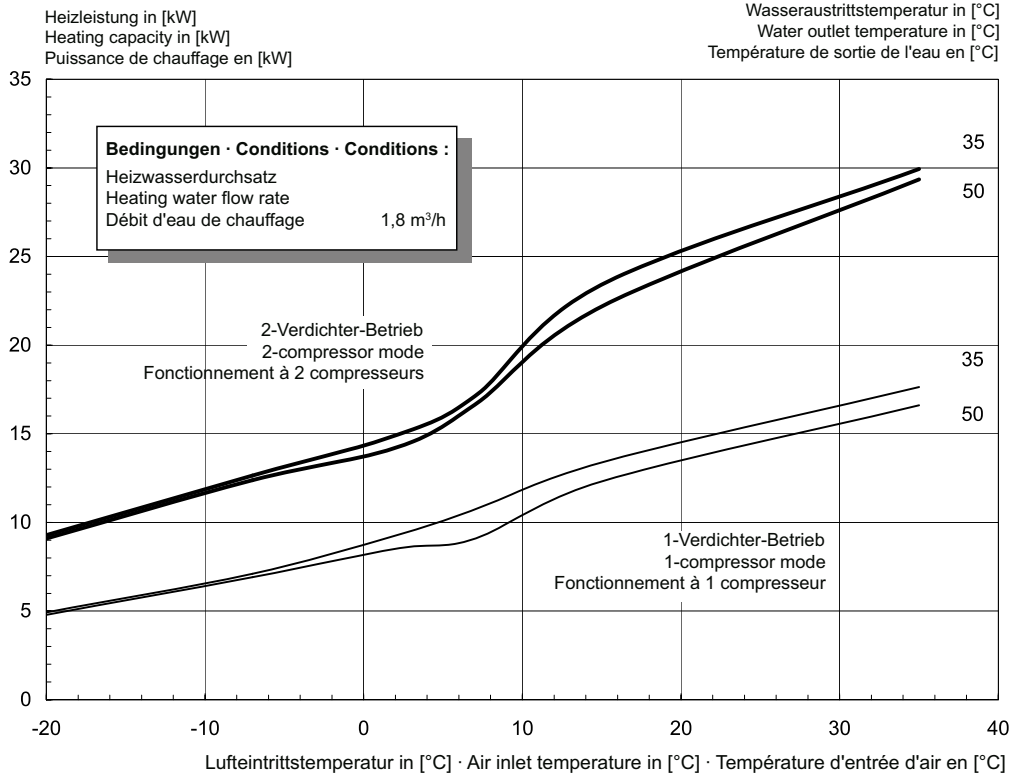

Anhang · Appendix · Annexes

## 2.2 Kennlinien / Characteristic curves / Courbes caractéristiques LI 24TEL

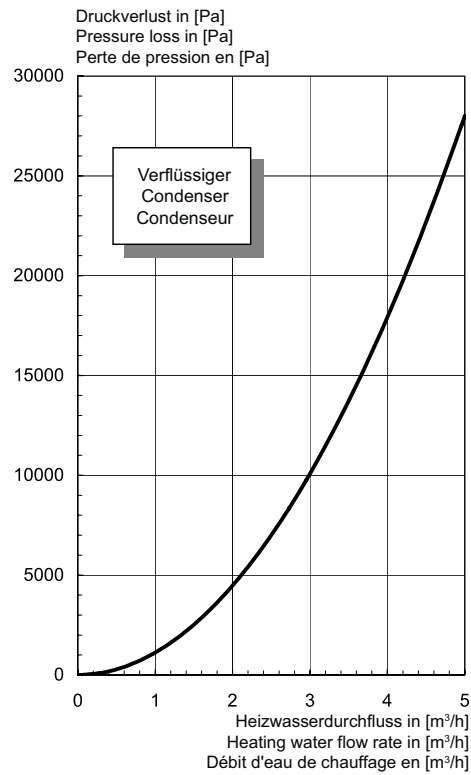
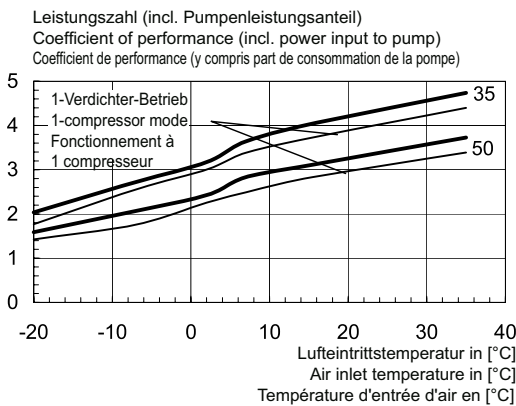
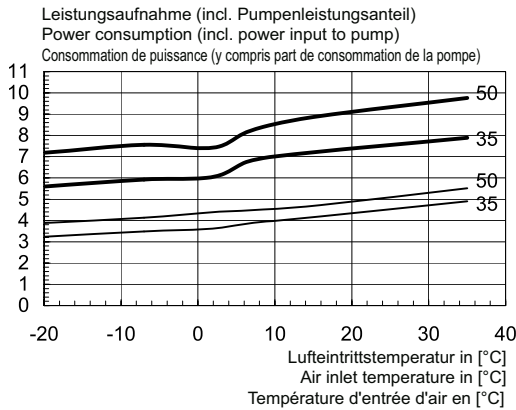
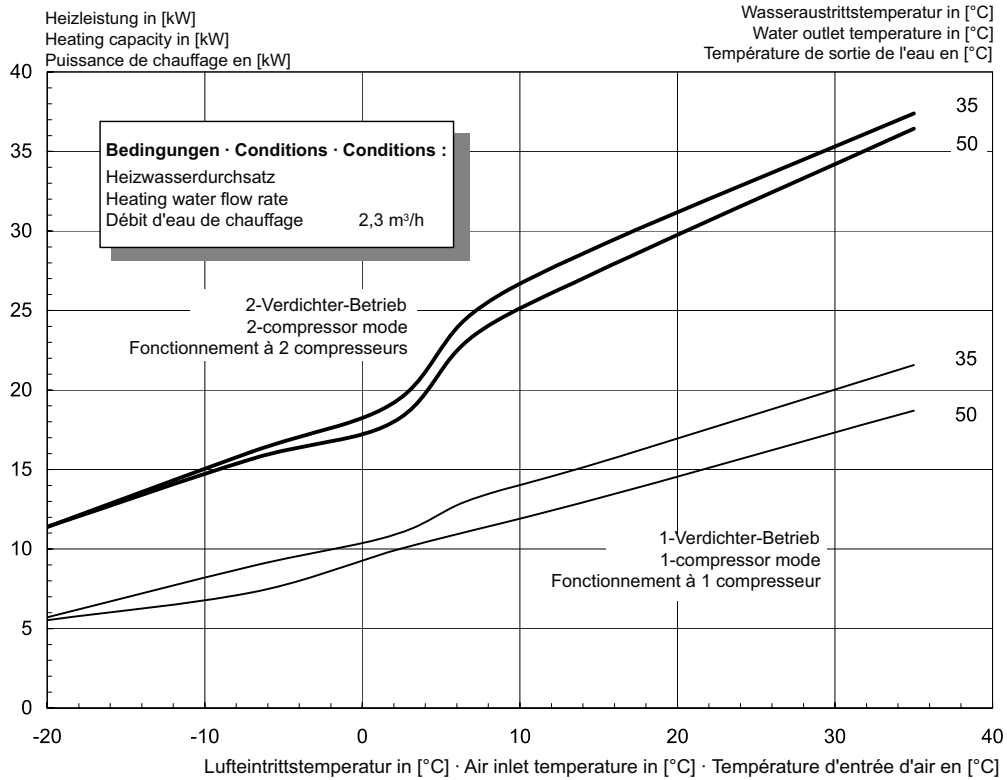

Anhang - Appendix - Annexes



## 2.3 Kennlinien / Characteristic curves / Courbes caractéristiques LI 28TEL

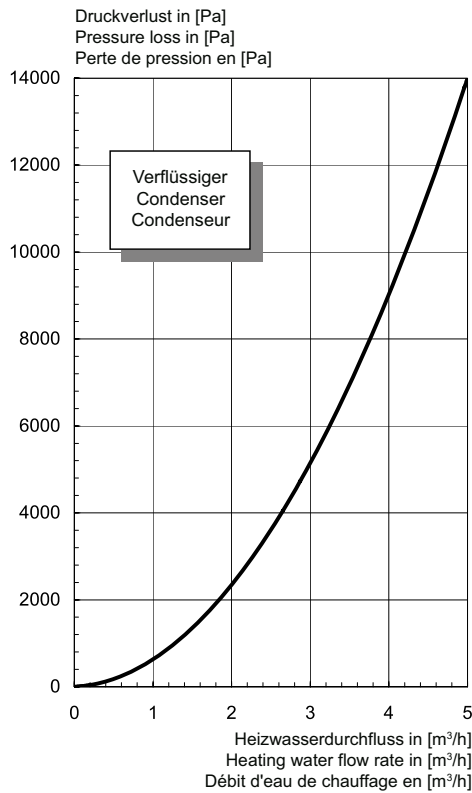
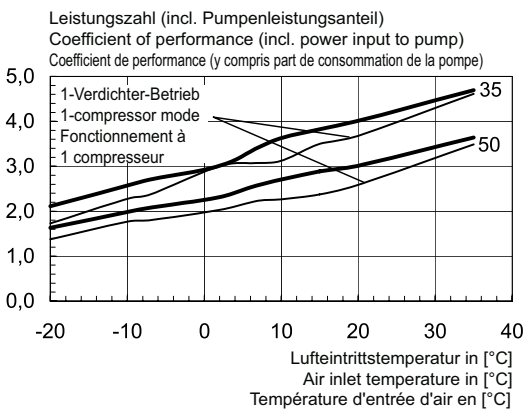
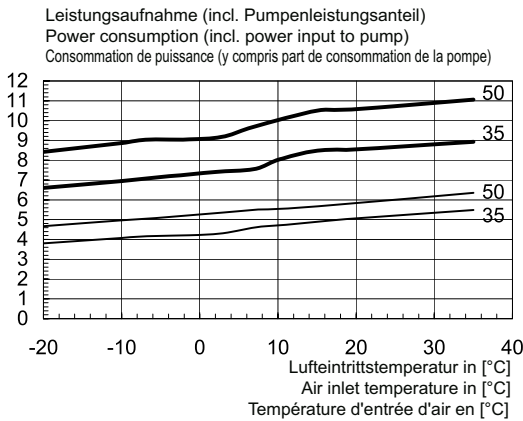
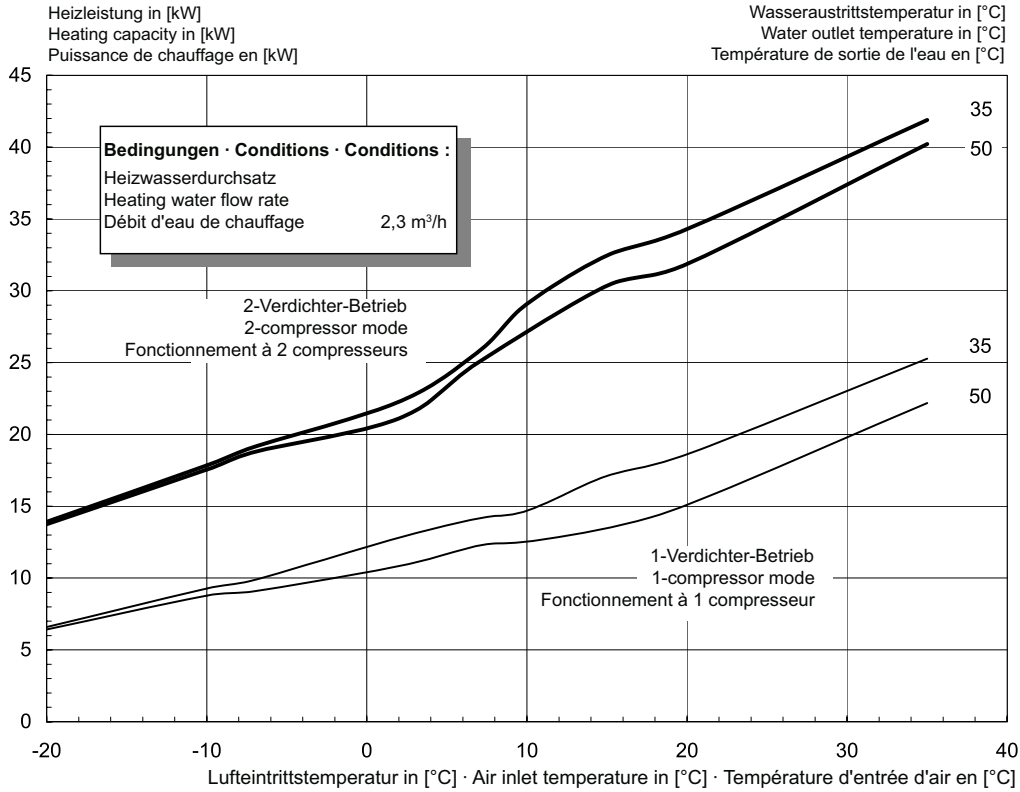

Anhang · Appendix · Annexes

# 3 Stromlaufpläne / Circuit Diagrams / Schémas électriques

## 3.1 Steuerung / Control / Commande

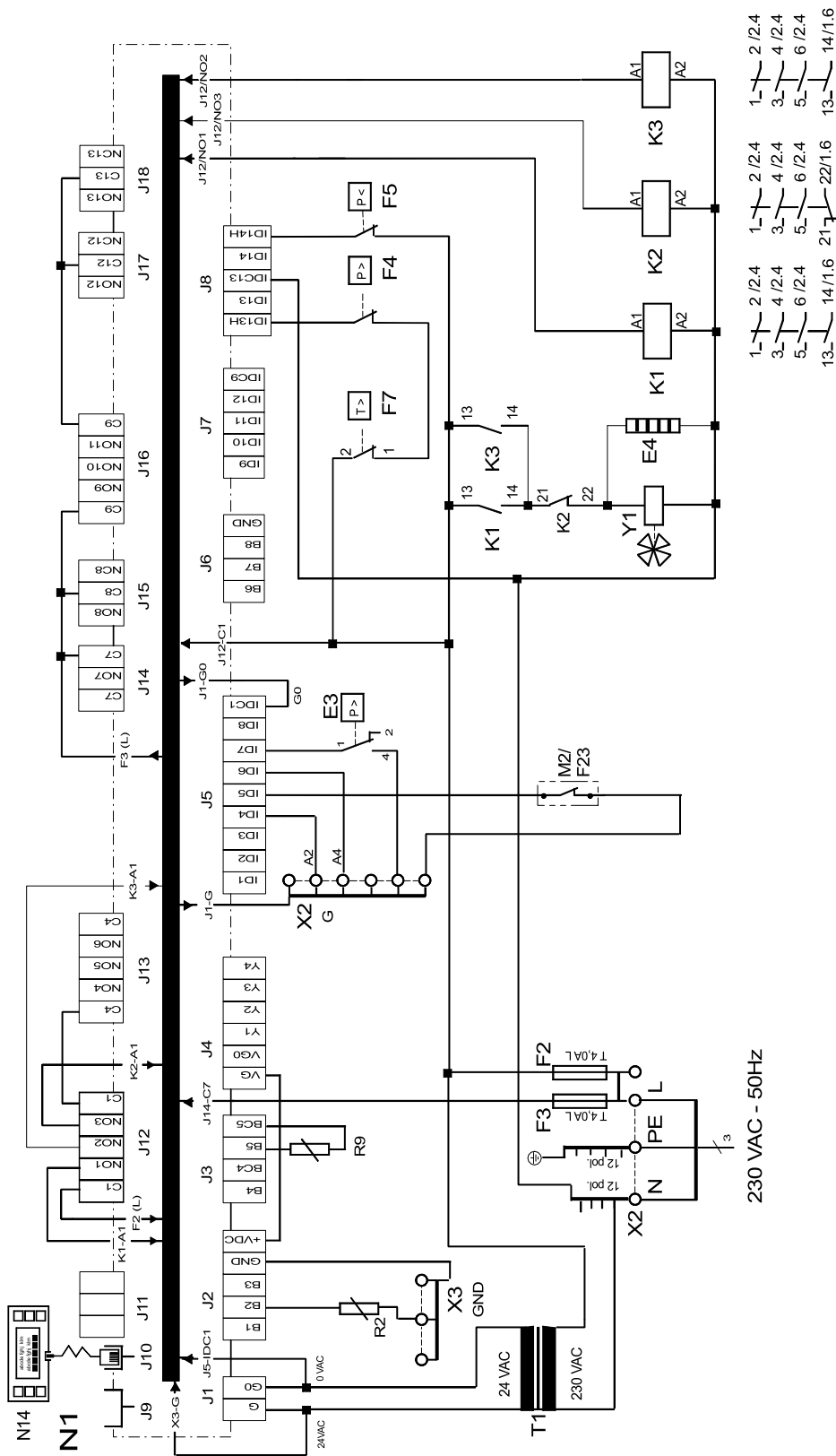

### 3.2 Last / Load / Charge

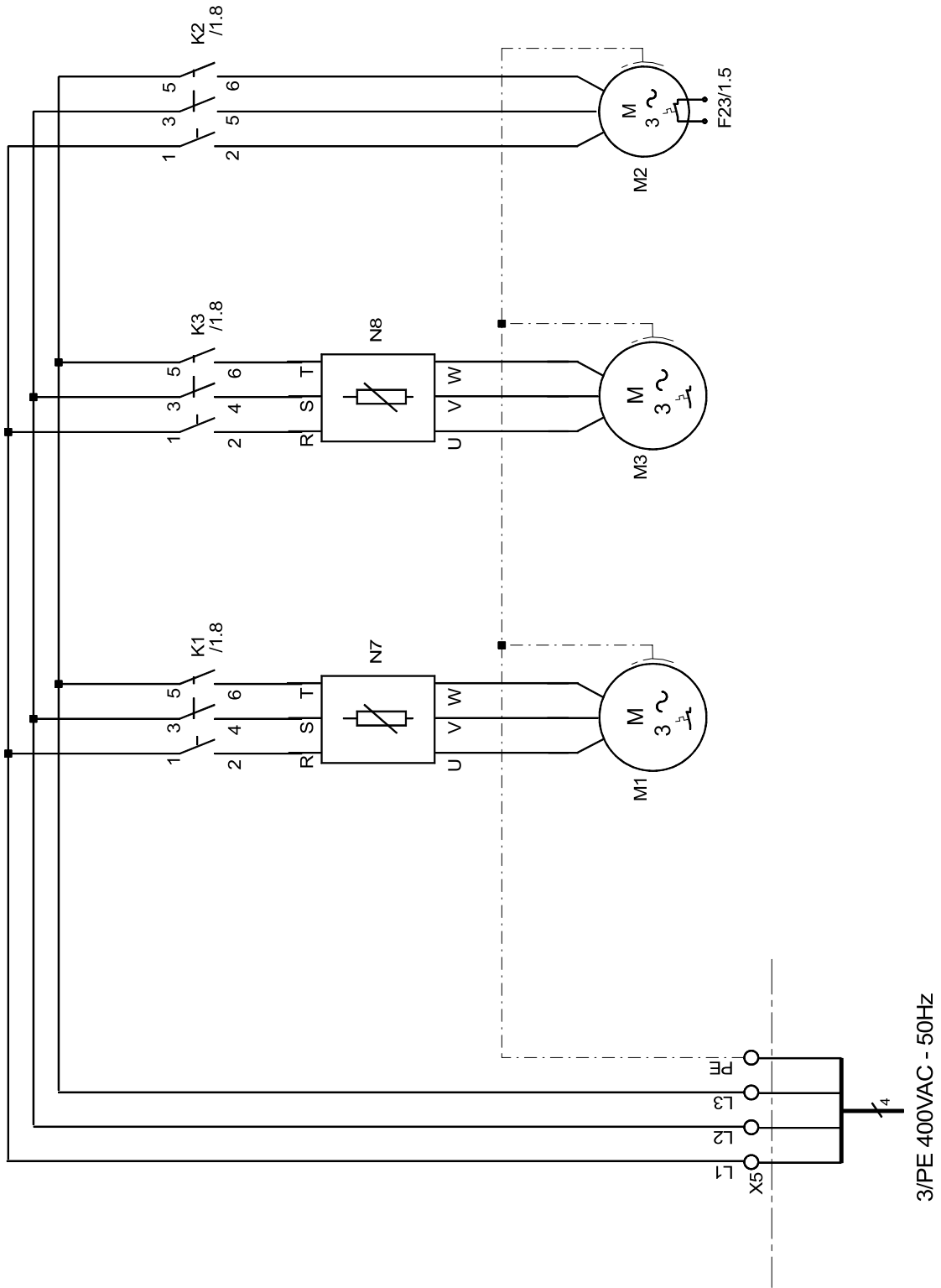

### 3.3 Anschlussplan / Circuit Diagram / Schéma électrique

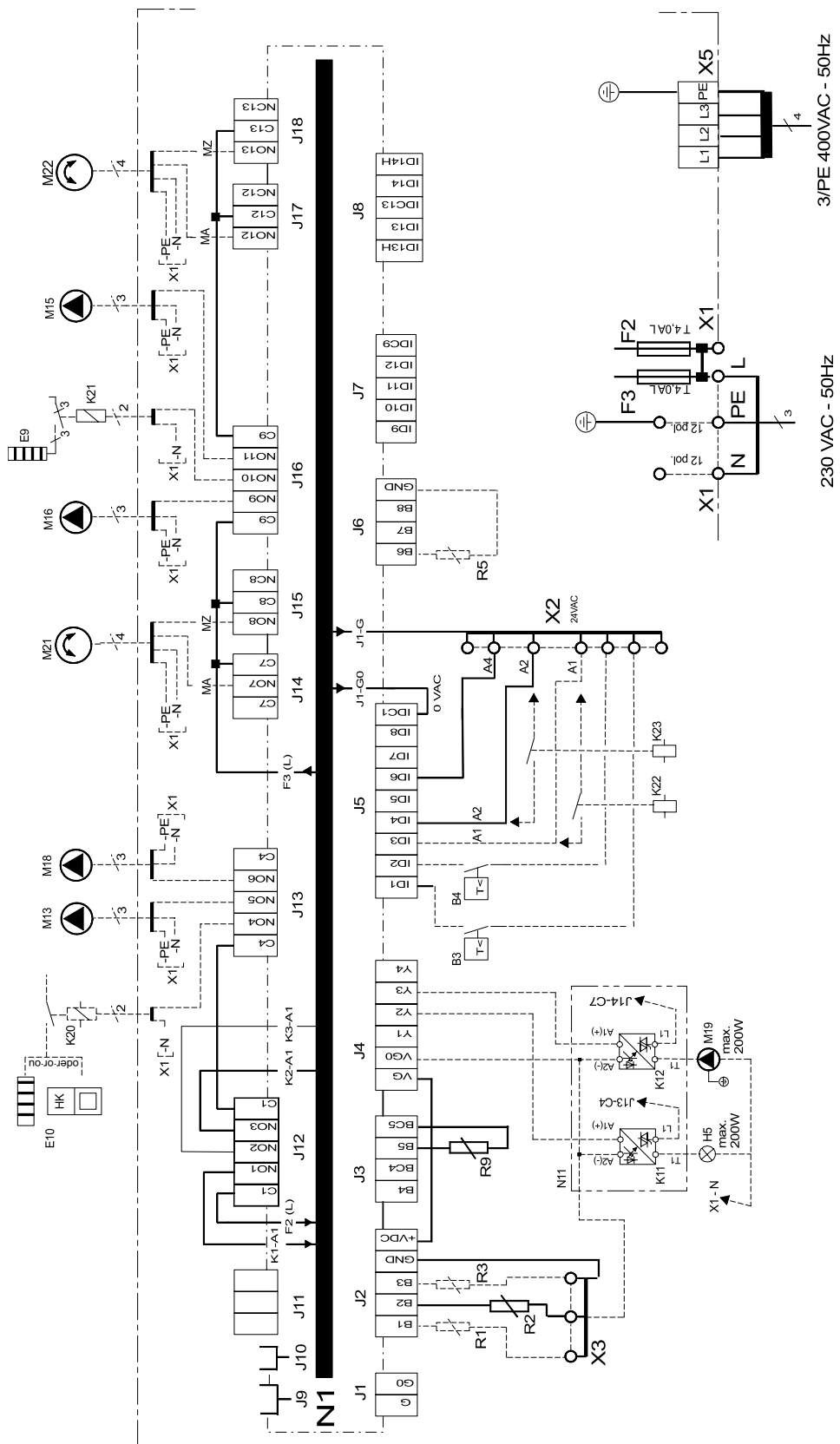

## 3.4 Legende / Legend / Légende

A1	Drahtbrücke einlegen wenn kein EVU-Sperrschütz benötigt wird (Eingang offen = EVU-Sperre = Wärmepumpe „aus“)	Wire jumper <b>must be inserted if no</b> utility blocking contactor is required (contact open = utility block = heat pump "off").	Cavalier à fil à <b>monter en absence</b> de contacteur de coupure du fournisseur d'énergie (pont ouvert = coupure société électricité = pompe à chaleur « arrêtée »)
A2	Drahtbrücke bei Nutzung des 2ten Sperreinganges entfernen (Eingang offen = Wärmepumpe „aus“)	Remove if the second disable connector is used (contact open = heat pump "off").	Cavalier à fil à retirer si la 2e entrée de coupure est utilisée (pont ouvert = pompe à chaleur « arrêtée »)
A4	Drahtbrücke Störung Verdichter M1	Wire jumper fault, M1 compressor	Cavalier dysfonctionnement compresseur M1
B3*	Thermostat Warmwasser	Hot water thermostat	Thermostat eau chaude
B4*	Thermostat Schwimmbadwasser	Swimming pool water thermostat	Thermostat eau de piscine
E3	Pressostat Abtauende	Defrost end controller	Pressostat fin de dégivrage
E4	Düsenringheizung	Nozzle ring heater	Chauffage à couronne perforée
E10*	2. Wärmegerzeuger Elektroheizung (Funktion ist über Regler wählbar)	2nd heat generator, electric heating (function selectable via controller)	2e générateur de chaleur chauffage électrique (fonction réglable par le régulateur)
F2	Sicherung für N1-Relaisausgänge an J12 und J13 4,0 ATR	Fuse for N1 relay outputs at J12 and J13 4.0 slow-acting	Fusible pour sorties de relais N1 en J12 et J13 4,0 ATR
F3	Sicherung für N1-Relaisausgänge an J15 bis J18 4,0 ATR	Fuse for N1 relay outputs at J15 to J18 4.0 slow-acting	Fusible pour sorties de relais N1 en J15 jusqu'à J18 4,0 ATR
F4	Pressostat Hochdruck	High-pressure switch	Pressostat haute pression
F5	Pressostat Niederdruck	Low-pressure switch	Pressostat basse pression
F7	Heißgastermostat	Hot gas thermostat	Thermostat gaz de chauffage
F23	Wicklungsschutz Ventilator	Winding protection, ventilator	Blindage de l'enroulement ventilateur
H5*	Leuchte Störferrnanzeige (Relaisbaugruppe)	Remote fault indicator lamp (relay module)	Témoin de télé-détection de pannes (sur module de relais)
J1	Stromversorgung-N1 (24V AC)	Power supply N1 (24 V AC)	Alimentation en courant N1 (24 V AC)
J2...J7	Niederspannungsein-/ausgänge	Low-voltage inputs/outputs	Entrées et sorties de basse tension
J8	Signalein-/ausgänge (230V AC)	Signal inputs/outputs (230V AC)	Entrées et sorties de signaux (230 V AC)
J9	Ohne Funktion	Has no function	Sans fonction
J10	Steckdose für Bedienteil	Socket for operating panel	Prise pour le panneau de commande
J11	Ohne Funktion	Has no function	Sans fonction
J12...J18	Relaisausgänge zur Ansteuerung der Systemkomponenten	Relay outputs for the control of system components	Sorties de relais pour la commande des composants du système
K1	Schütz Verdichter 1	Contacteur for compressor 1	Contacteur compresseur 1
K2	Schütz Ventilator	Contacteur for ventilator	Contacteur ventilateur
K3	Schütz Verdichter 2	Contacteur for compressor 2	Contacteur compresseur 2
K11*	Elektron. Relais f. Störferrnanzeige (Relaisbaugruppe)	Electron. remote fault indicator relay (relay module)	Relais pour télé-détection de pannes (sur module de relais)
K12*	Elektron. Relais f. Schwimmbadwasserumwälzpumpe (Relaisbaugruppe)	Electron. relay for swimming pool water circulating pump (relay module)	Relais pour circulateur d'eau de piscine (sur module de relais)
K20*	Schütz 2. Wärmegerzeuger	Contacteur, suppl. heating system	Contacteur 2ème générateur de chaleur
K22*	EVU-Sperrschütz	Utility blocking contactor	Contacteur de coupure du fournisseur d'énergie
K23*	SPR-Hilfsrelais	SPR auxiliary relay	Relais auxiliaire « SPR »
M1	Verdichter 1	Compressor 1	Compresseur 1
M2	Ventilator	Ventilator	Ventilateur
M3	Verdichter 2	Compressor 2	Compresseur 2
M13*	Heizungsumwälzpumpe Hauptkreis	Heat circulating pump of the main circuit	Circulateur de chauffage circuit principal
M15*	Heizungsumwälzpumpe 2. Heizkreis	Heat circulating pump for heating circuit 2	Circulateur de chauffage 2e circuit de chauffage
M16*	Zusatzumwälzpumpe	Auxiliary circulating pump	Circulateur supplémentaire
M18*	Warmwasserumwälzpumpe	Hot water circulating pump	Circulateur d'eau chaude
M19*	Schwimmbadwasserumwälzpumpe	Swimming pool water circulating pump	Circulateur d'eau de piscine
M21*	Mischer Hauptkreis	Mixer for main circuit	Mélangeur circuit principal
M22*	Mischer 2. Heizkreis	Mixer for heating circuit 2	Mélangeur 2e circuit de chauffage
N1	Wärmepumpenregler	Heat pump controller	Régulateur de pompe à chaleur
N7	Sanftanlaufsteuerung Verdichter 1	Soft start control for compressor 1	Commande de démarrage progressif pour compresseur 1
N8	Sanftanlaufsteuerung Verdichter 2	Soft start control for compressor 2	Commande de démarrage progressif pour compresseur 2
N14	Bedienteil	Operating element	Commande
R1	Außentemperaturfühler	External temperature sensor	Sonde de température extérieure
R2	Rücklauffühler-Heizung	Return flow sensor for heating system	Sonde retour chauffage
R3	Warmwasserfühler (alternativ zum Warmwasserthermostat)	Hot water sensor (as an alternative to the hot water thermostat)	Sonde d'eau chaude (alternative au thermostat eau chaude)
R5	Fühler für den 2ten Heizkreislauf	Sensor for heating circuit 2	Sonde pour le 2e circuit de chauffage
R9	Vorlauffühler	Flow sensor	Sonde aller
T1	Sicherheitstrenntransformator 230/24 VAC-50Hz/28VA	Safety isolating transformer 230/24 V AC-50 Hz/28 VA	Transformateur sectionneur de sécurité 230/24 VAC-50Hz/28VA
X1	Klemmenleiste: Einspeisung Last 3L/PE 400VAC ~ 50Hz	Terminal strip: load infeed 3L/PE 400VAC ~ 50Hz	Bornier : alimentation puissance 3L/PE 400 VAC ~ 50 Hz
X2	Klemmenleiste: Einspeisung Steuerspannung L/N/PE 230VAC ~ 50Hz	Terminal strip: control voltage infeed L/N/PE 230 V AC ~ 50 Hz	Bornier : bornier tension de commande L/N/PE-230 V AC ~ 50Hz
X3	Klemmenleiste: Kleinspannung	Terminal strip: extra-low voltage	Bornier : tension de sécurité
Y1	Vier-Wege-Umschaltventil	Four-way valve	Vanne d'inversion 4 voies
	<b>Abkürzungen:</b>	<b>Abbreviations:</b>	<b>Abréviations :</b>
	EVU Energieversorgungsunternehmen	Utility company	Société de production et de distribution d'énergie
	SPR Sperr	Block	Blocage
	MA Mischer AUF	Mixer OPEN	Mélangeur OUVERT
	MZ Mischer ZU	Mixer CLOSED	Mélangeur FERME
	* Bauteile sind extern beizustellen	Components to be supplied from external sources	Pièces à fournir par le client
	- - - - bauseits bei Bedarf anzuschließen	To be connected by the customer as required	à raccorder par le client au besoin
	— werkseitig verdrahtet	Wired ready for use	câblé départ usine

## 4 Hydraulische Prinzipschemen / Hydraulic Plumbing Diagrams / Schémas hydrauliques

### 4.1 Monoenergetische Anlage / Mono energy system / Installation mono-énergétique

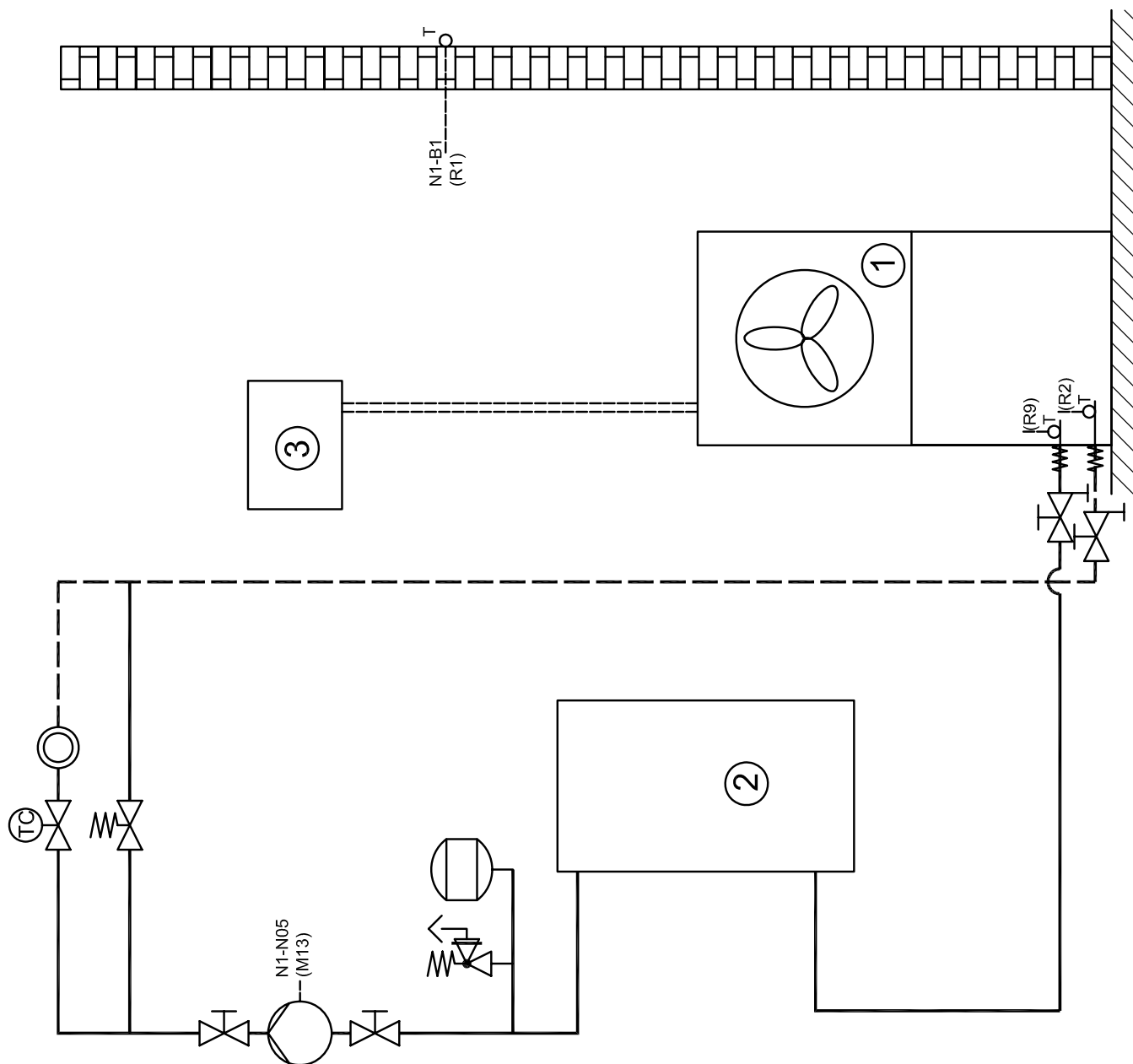

## 4.2 Monoenergetische Anlage und Warmwasserbereitung / Mono energy system and domestic hot water preparation / Installation mono-énergétique et production d'eau chaude

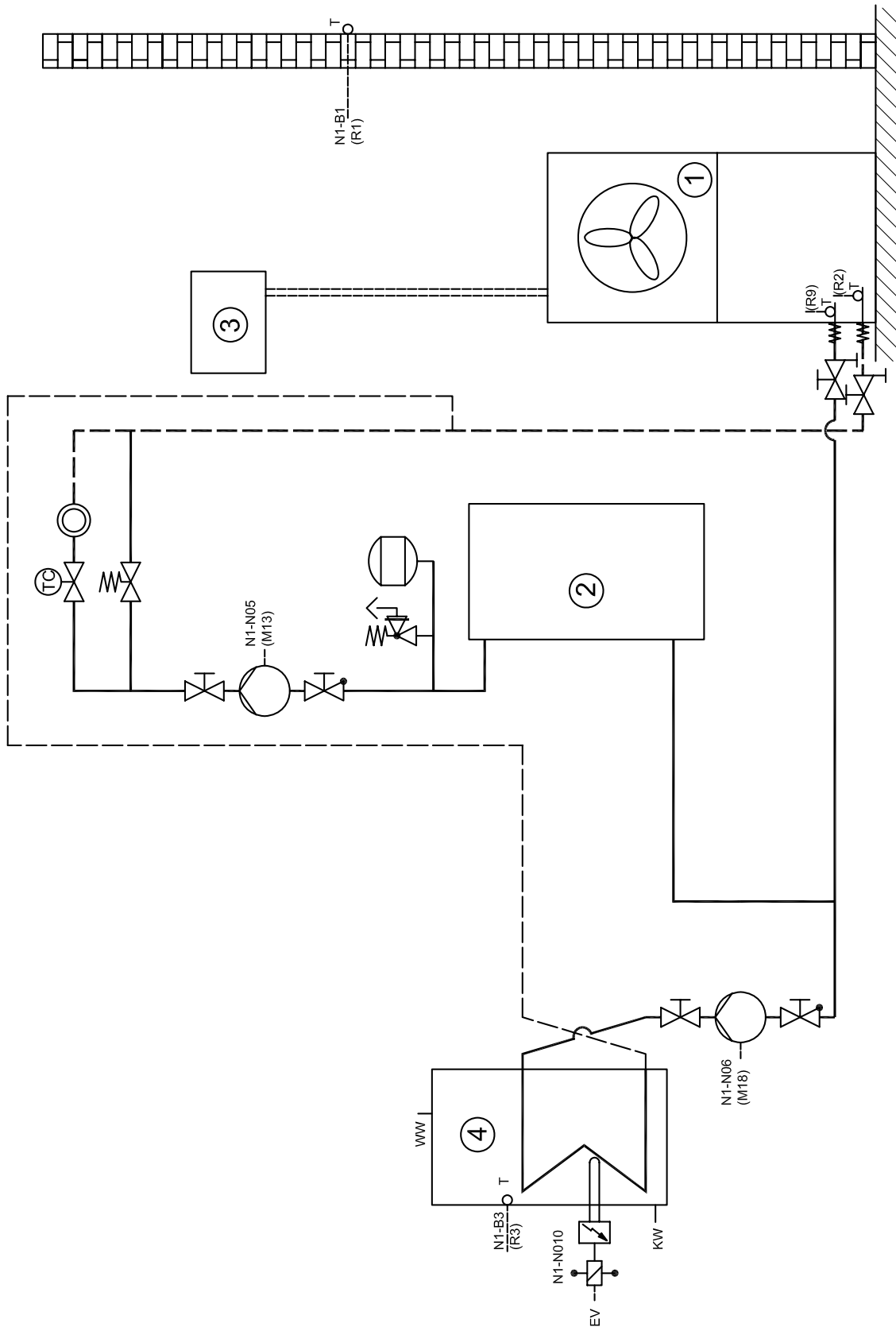



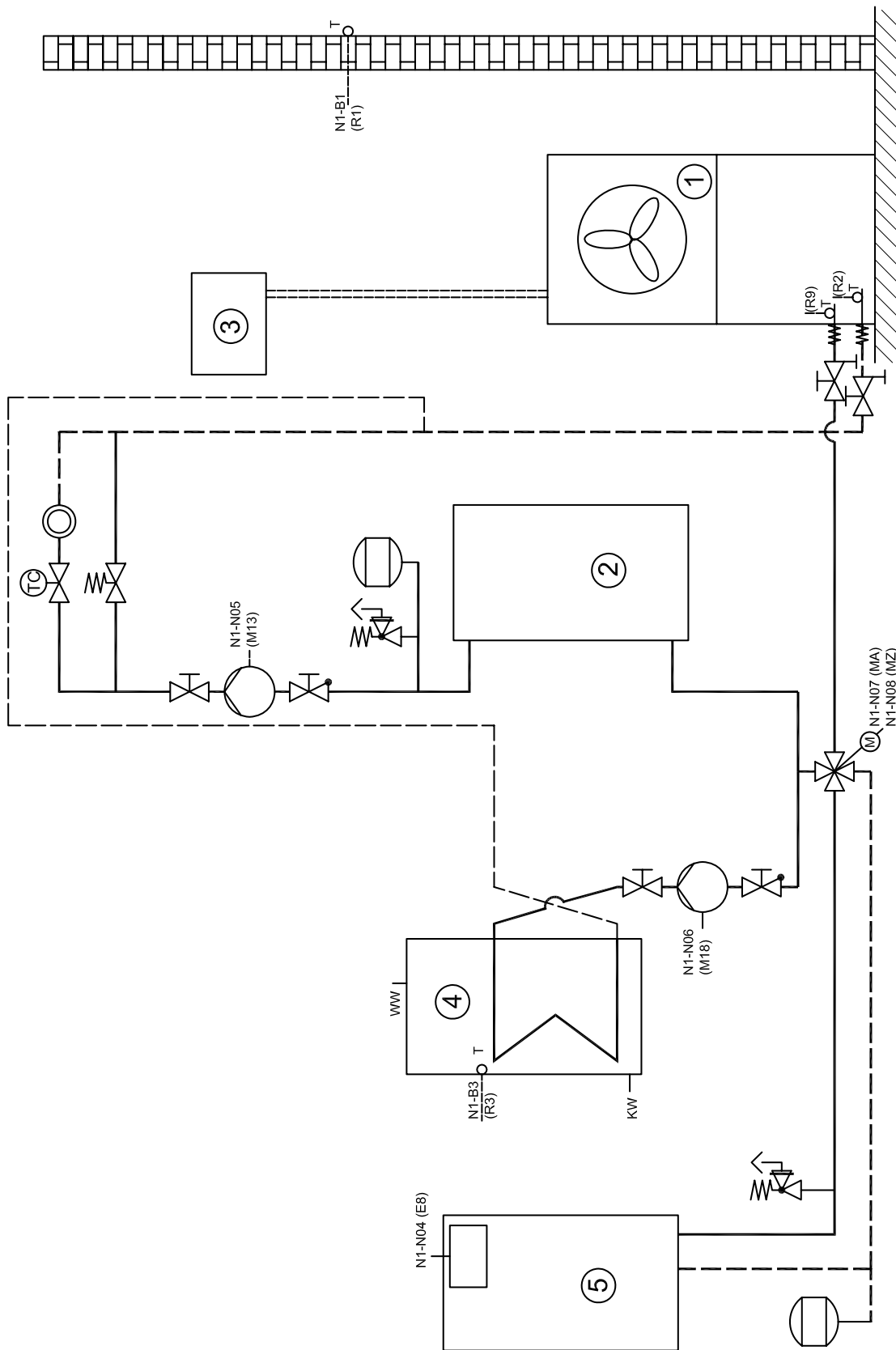





### 4.3 Bivalente Anlage / Bivalent system / Installation bivalente





## 4.4 Legende / Legend / Légende

	Absperrventil	Shutoff valve	Robinet d'arrêt
	Überstromventil	Overflow valve	Vanne de trop-plein
	Sicherheitsventilkombination	Safety valve combination	Groupe de valves de sécurité
	Umwälzpumpe	Circulating pump	Circulateur
	Ausdehnungsgefäß	Expansion vessel	Vase d'expansion
	Raumtemperaturgesteuertes Ventil	Room temperature-controlled valve	Valve commandée par température
	Absperrventil mit Rückschlagventil	Shutoff valve with check valve	Robinet d'arrêt avec clapet anti-retour
	Absperrventil mit Entwässerung	Shutoff valve with drainage	Robinet d'arrêt avec écoulement
	Wärmeverbraucher	Heat consumer	Consommateur de chaleur
	Vierwegemischer	Four-way mixer	Mélangeur 4 voies
	Temperaturfühler	Temperature sensor	Sonde de température
	Flexibler Anschlusschlauch	Flexible connection hose	Tuyau de raccord flexible
①	Wärmepumpe	Heat pump	Pompe à chaleur
②	Pufferspeicher	Buffer tank	Réservoir tampon
③	Elektroverteilung	Electrical distribution system	Distributeur courant électrique
④	Warmwasserspeicher	Hot water cylinder	Ballon d'eau chaude
⑤	Heizkessel	Boiler	Chaudière
E10	Zusatzheizung	Supplementary heating	Chauffage d'appoint
M13	Heizungsumwälzpumpe	Heat circulating pump	Circulateur de chauffage
M18	Warmwasserumwälzpumpe	Hot water circulating pump	Circulateur d'eau chaude
N1	Wärmepumpenregler	Heat pump controller	Régulateur de pompe à chaleur
R1	Außenwandfühler	External wall sensor	Sonde de paroi extérieure
R2	Rücklauffühler	Return flow sensor	Sonde de retour
R3	Warmwasserfühler	Hot water sensor	Sonde d'eau chaude
R9	Vorlauffühler	Flow sensor	Sonde aller
EV	Elektroverteilung	Electrical distribution system	Distributeur courant électrique
KW	Kaltwasser	Cold water	Eau froide
MA	Mischer AUF	Mixer OPEN	Mélangeur OUVERT
MZ	Mischer ZU	Mixer CLOSED	Mélangeur FERME
WW	Warmwasser	Domestic hot water	Eau chaude

# 5 Konformitätserklärung / Declaration of Conformity / Déclaration de conformité

## EG - Konformitätserklärung EC Declaration of Conformity Déclaration de conformité CE

Der Unterzeichnete  
The undersigned  
La société soussignée.

**Glen Dimplex Deutschland GmbH**  
**Geschäftsbereich Dimplex**  
**Am Goldenen Feld 18**  
**D - 95326 Kulmbach**

bestätigt, dass das (die) nachfolgend be-  
zeichnete(n) Gerät(e) aufgrund seiner (ihrer)  
Konzipierung und Bauart sowie in der von  
uns in Verkehr gebrachten Ausführung den  
einschlägigen grundlegenden Anforderungen  
der EG-Richtlinien entspricht (entsprechen).

Bei einer nicht mit uns abgestimmten  
Änderung des (der) Gerät(e)s verliert  
diese Erklärung ihre Gültigkeit.

hereby confirm that the design and con-  
struction of the product(s) listed below,  
in the version(s) placed on the market by  
us, conform to the relevant requirements  
of the applicable EC directives.

This declaration becomes invalidated  
if any modifications are made to  
the product(s) without our prior  
authorisation.

certifie que l'appareil / les appareils ci-  
après, par leur conception et leur mode de  
construction ainsi que par la définition  
technique avec laquelle il(s) sont mis en  
circulation par notre société, est / sont  
conforme(s) aux directives fondamentales  
CEE afférentes.

Ce certificat perd sa validité pour tout  
appareil modifié sans notre consentement.

### Bezeichnung / Designation / Désignation

**Luft/Wasser-Wärmepumpen**  
für Innenaufstellung mit R404A

**Air-to-water heat pumps**  
for indoor installation, containing R404A

**Pompes à chaleur air/eau**  
pour installation intérieure avec R404A

### EG - Richtlinien / EC Directives / Directives CEE

EG- Niederspannungsrichtlinie / EC Low Voltage Directive /  
Directive CEE relative à la basse tension (2006/95/EG)

EG-EMV-Richtlinie / EC EMC Directive / Directive CEE  
relative à la compatibilité électromagnétique (89/336/EWG)

Druckgeräterichtlinie / Pressure Equipment Directive /  
Directive CEE relative aux appareils sous pression (97/23/EG)

### Typ(e):

### Harmonisierte EN / Harmonized EB Standards / Normes EN harmonisées:

<b>LI 11TEL</b>	EN 255:1997	
<b>LI 16TEL</b>	EN 378:2000	
<b>LI 20TEL</b>	DIN 8901	
<b>LI 24TEL</b>	DIN EN 60335-1 (VDE 0700 T1):2006	EN 60335-1:2002+A11+A1+A12+ Corr.+A2:2006
<b>LI 28TEL</b>	DIN EN 60335-2-40 (VDE 0700 T40):2006-11	EN 60335-2-40:2003+A11+A12+A1+Corr.:2006
	DIN EN 55014-1 (VDE 0875 T14-1):2003-09	EN 55014-1:2000+A1:2001+A2:2002
	DIN EN 55014-2 (VDE 0875 T14-2):2002-08	EN 55014-2:1997+A1:2001
	DIN EN 61000-3-2 (VDE 0838 T2):2005-09	EN 61000-3-2:2000+A2:2005
	DIN EN 61000-3-3 (VDE 0838 T3):2002-05	EN 61000-3-3:1995+Corr.:1997+A1:2001

### Nationale Richtlinien / National Directives / Directives nationales

<u>D</u>	<u>A</u>	<u>CH</u>
BGR 500		SVTI

Kulmbach, 09.02.2007

CE02W01F.doc

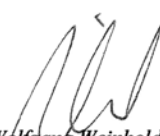
  
Wolfgang Weinhold  
Geschäftsführer / Managing Director

  
Andreas Tilch  
Spartenleiter / Head of business unit

---

Glen Dimplex Deutschland GmbH  
Geschäftsbereich Dimplex  
Am Goldenen Feld 18  
D-95326 Kulmbach

Irrtümer und Änderungen vorbehalten.  
Subject to alterations and errors.  
Sous réserve d'erreurs et modifications.  
 +49 (0) 9221 709 565  
[www.dimplex.de](http://www.dimplex.de)

## Free Manuals Download Website

<http://myh66.com>

<http://usermanuals.us>

<http://www.somanuals.com>

<http://www.4manuals.cc>

<http://www.manual-lib.com>

<http://www.404manual.com>

<http://www.luxmanual.com>

<http://aubethermostatmanual.com>

Golf course search by state

<http://golfingnear.com>

Email search by domain

<http://emailbydomain.com>

Auto manuals search

<http://auto.somanuals.com>

TV manuals search

<http://tv.somanuals.com>