

ASSEMBLY

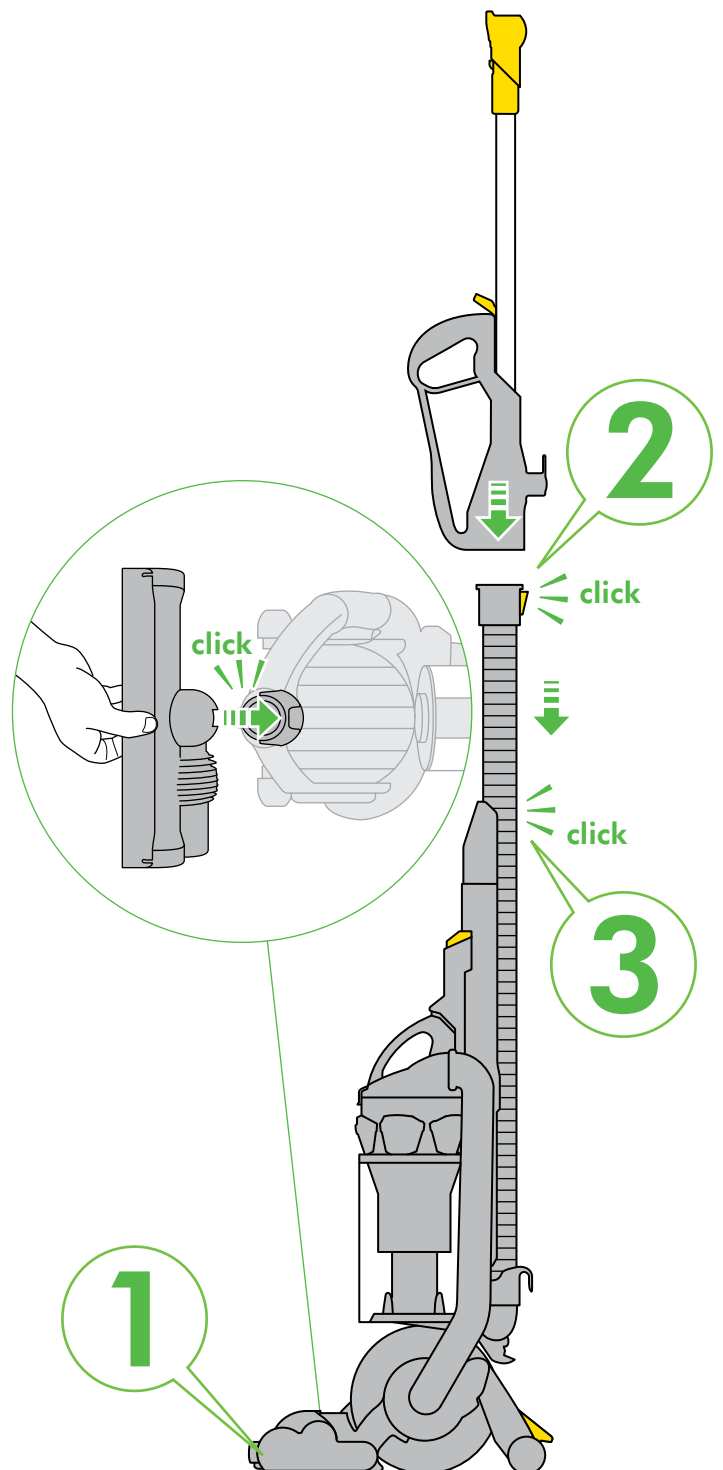

Your Dyson vacuum cleaner will be covered for parts and labour for 2 years from the date of purchase, as detailed in the terms of the Dyson guarantee on page 9 of this Dyson Operating Manual.

If you have a query about your Dyson vacuum cleaner, call the Dyson Customer Care Helpline with your serial number and details of where and when you bought the vacuum cleaner. Your serial number can be found on the main body of the vacuum cleaner behind the clear bin.

Most queries can be solved over the phone by one of our Dyson Customer Care Helpline staff (details below).

Visit our website to register your Dyson full parts and labour guarantee online (Australia and New Zealand only).

AU: www.dyson.com.au/register

NZ: www.dyson.co.nz/register

Note your serial number for future reference



This illustration is for example purposes only.

IMPORTANT SAFETY PRECAUTIONS

READ ALL INSTRUCTIONS BEFORE USING THIS APPLIANCE

When using an electrical appliance, basic precautions should always be followed, including the following:

! WARNING

TO REDUCE THE RISK OF FIRE, ELECTRIC SHOCK, OR INJURY:

1. Do not leave the Dyson vacuum when plugged in. Unplug from socket when not in use and before servicing
2. Do not use outdoors or on wet surfaces. Suitable for dry locations only. Do not use to pick up water.
3. Do not allow to be used as a toy. Close attention is necessary when used by or near children. Children should be supervised to ensure that they do not play with the Dyson vacuum.
4. This Dyson vacuum is not intended for use by young children or infirm persons with reduced physical, sensory or reasoning capabilities, or lack of experience and knowledge, unless they have been given supervision or instruction by a responsible person concerning use of the Dyson vacuum to ensure that they can use the Dyson vacuum safely.
5. Use only as described in this manual. Use only Dyson recommended accessories and replacement parts. Do not carry out any maintenance other than that shown in this manual, or advised by the Dyson Customer Care Helpline. Contact the Dyson Customer Care Helpline when service or repair is required. Do not disassemble the Dyson vacuum as incorrect reassembly may result in an electric shock or fire.
6. Do not use with a damaged cable or plug. If the Dyson vacuum is not working as it should, has been dropped, damaged, left outdoors, or dropped into water, do not use and contact the Dyson Customer Care Helpline. If the supply cable is damaged it must be replaced by Dyson, its service agent or similarly qualified person in order to avoid a hazard.
7. Do not pull or carry by cable, use cable as a handle, close a door on cable, or pull cable around sharp edges or corners. Do not run the Dyson vacuum over cable. Keep cable away from heated surfaces. To avoid a tripping hazard wind the cable when not in use.
8. Do not unplug by pulling on the cable. To unplug, grasp the plug, not the cable.
9. Do not handle the plug or Dyson vacuum with wet hands.
10. Do not put any object into openings. Do not use with any opening blocked; keep free of dust, lint, hair, and anything that may reduce airflow.
11. Keep hair, loose clothing, fingers, and all parts of body away from openings and moving parts, such as the brush bar. Do not point the hose, wand or tools at your eyes or ears or put them in your mouth.
12. Turn off all controls before unplugging.
13. Use extra care when cleaning on stairs. Do not work with the Dyson vacuum above you on the stairs.
14. Do not use to pick up flammable or combustible liquids, such as gasoline, or use in areas where they or their vapours may be present.
15. Do not pick up anything that is burning or smoking, such as cigarettes, matches, or hot ashes.
16. Do not use without the clear bin and filters in place.
17. The use of an extension cable is not recommended.

3 EASY WAYS TO REGISTER YOUR DYSON 2 YEAR GUARANTEE

REGISTER ONLINE

Visit our website to register your Dyson full parts and labour guarantee online (Australia and New Zealand only).

AU: www.dyson.com.au/register
NZ: www.dyson.co.nz/register

REGISTER BY PHONE

Call our dedicated Helpline.

AU 1800 239 766
NZ 0800 397 667
SG 7000 435 7546
ID 021 707 39766

REGISTER BY MAIL

Complete and return the form to Dyson in the envelope supplied.

READ AND SAVE THESE INSTRUCTIONS

THIS DYSON VACUUM IS INTENDED FOR HOUSEHOLD USE ONLY

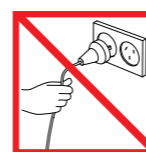

Do not pull on the cable.

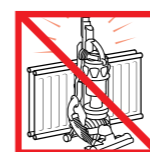

Do not store near heat sources.



Do not use near naked flame.



Do not run over the cable.



Do not pick up water or liquids.



Do not pick up burning objects.



Do not use above you on the stairs.



Do not put hands near the brush bar when the vacuum cleaner is in use.

Usage

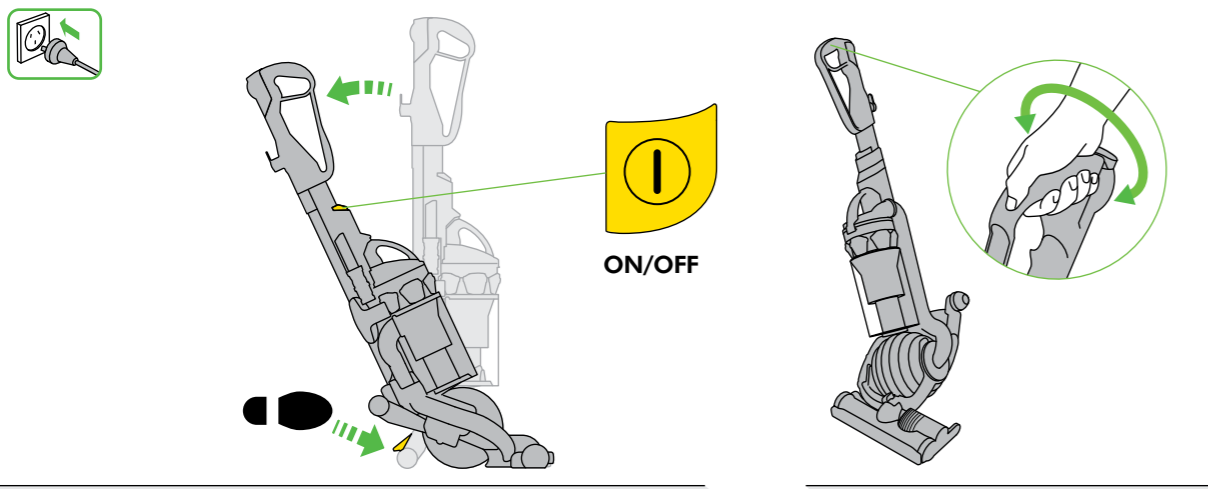

Carpets/hard floors

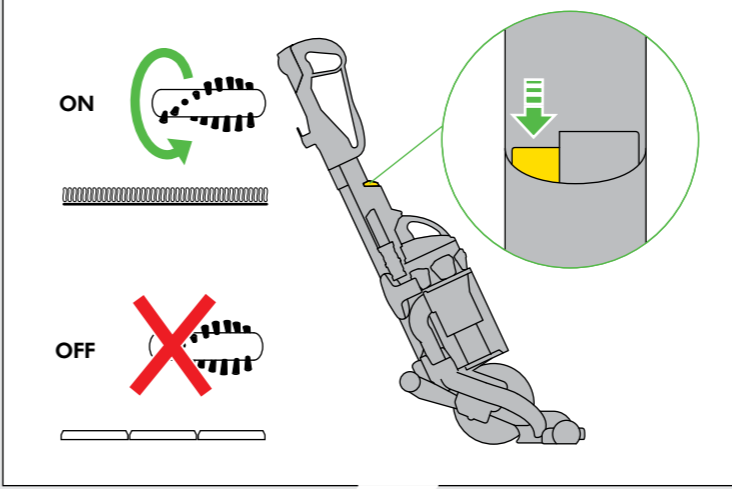

High-reach cleaning

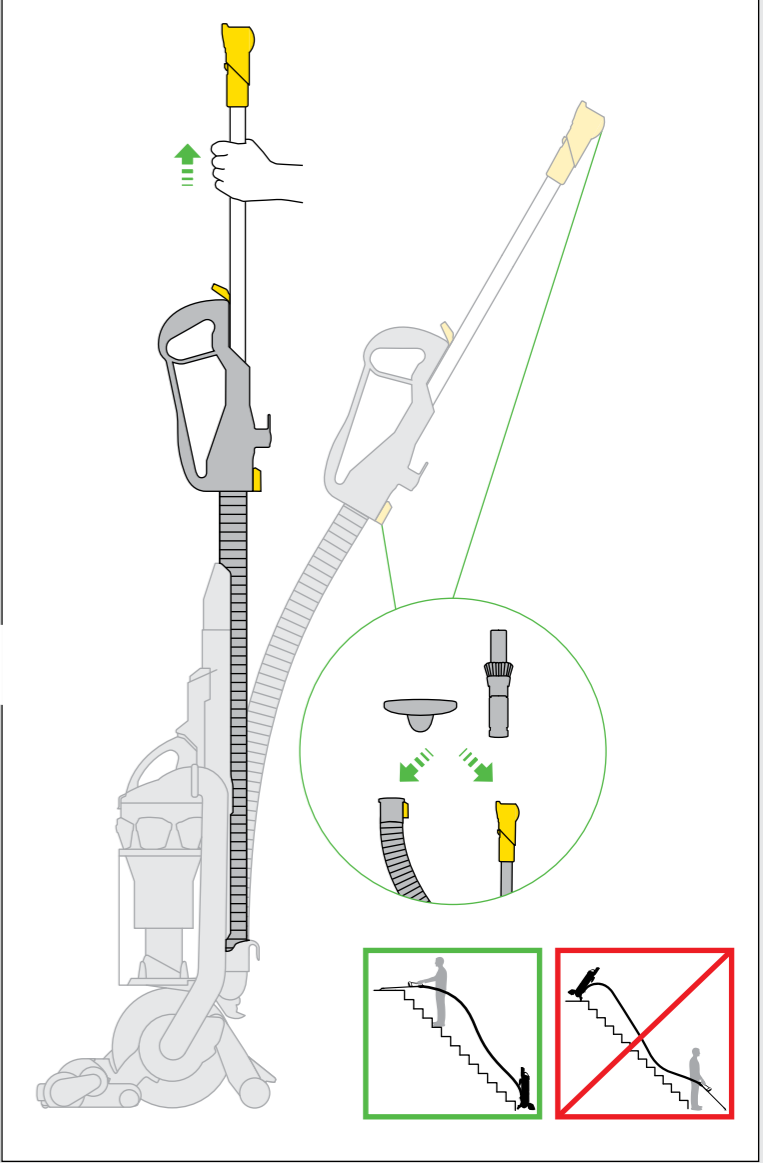

Emptying the clear bin

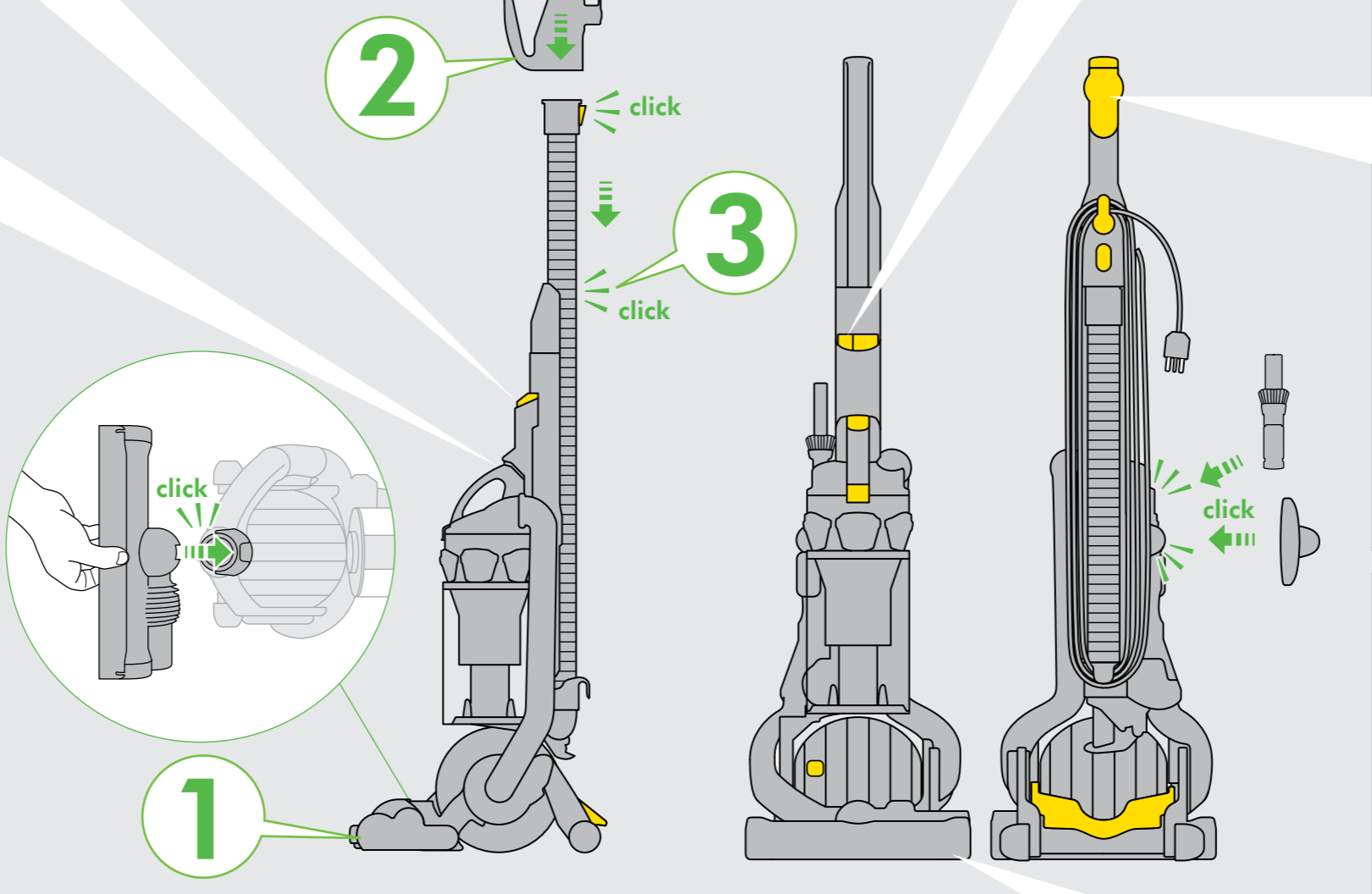
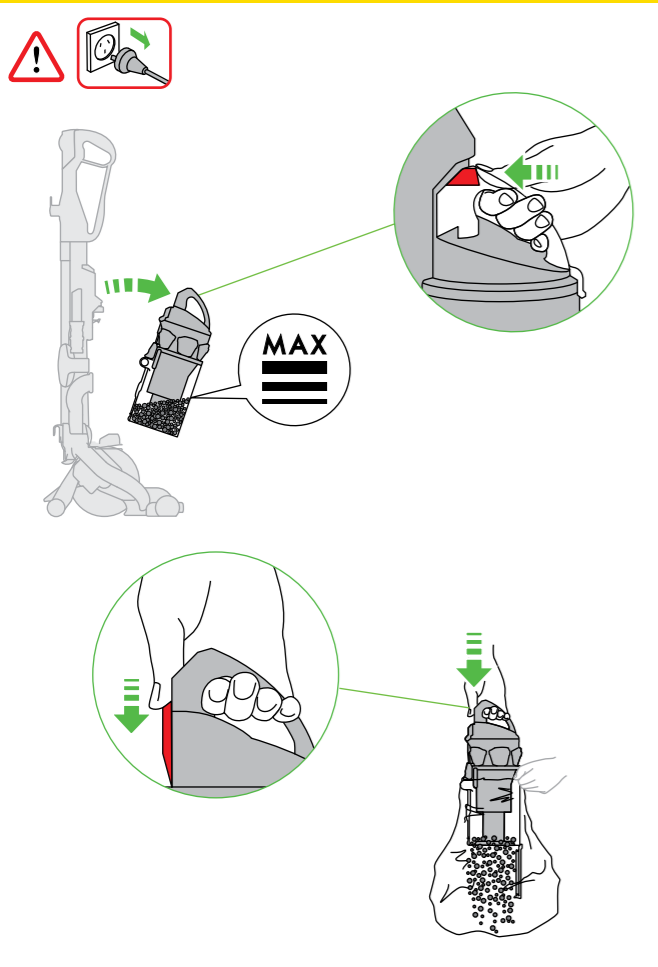

Looking for blockages

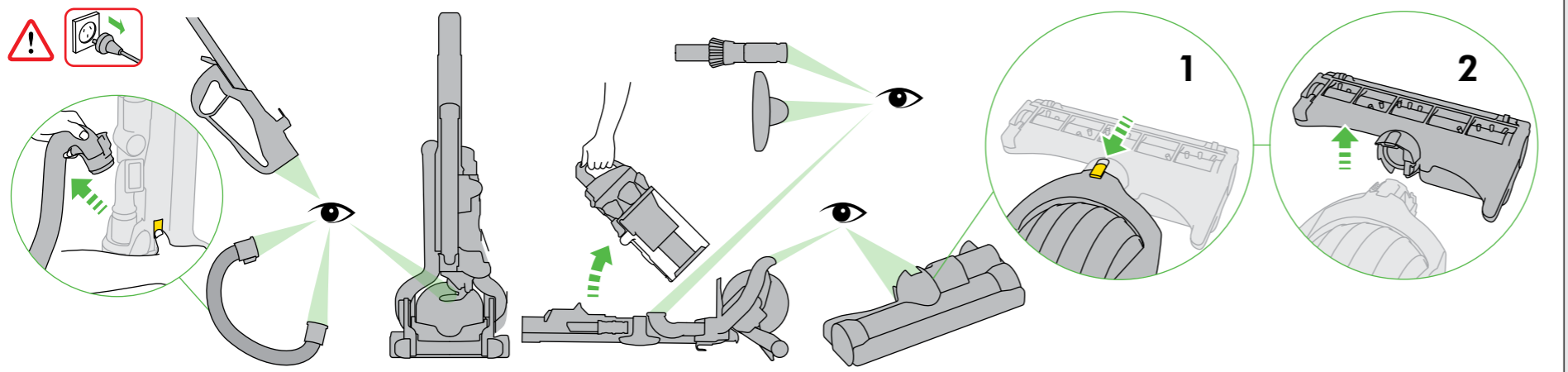

Clearing brush bar obstructions

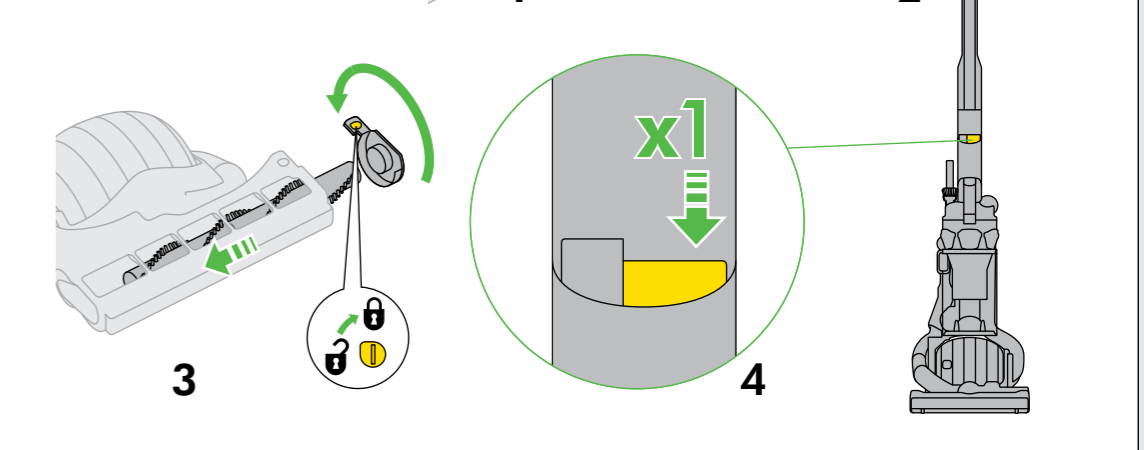

IMPORTANT!

WASH FILTERS



Wash filters with cold water regularly or as required.

Register for a filter wash reminder by email (Australia only):
customer care@dyson.com.au

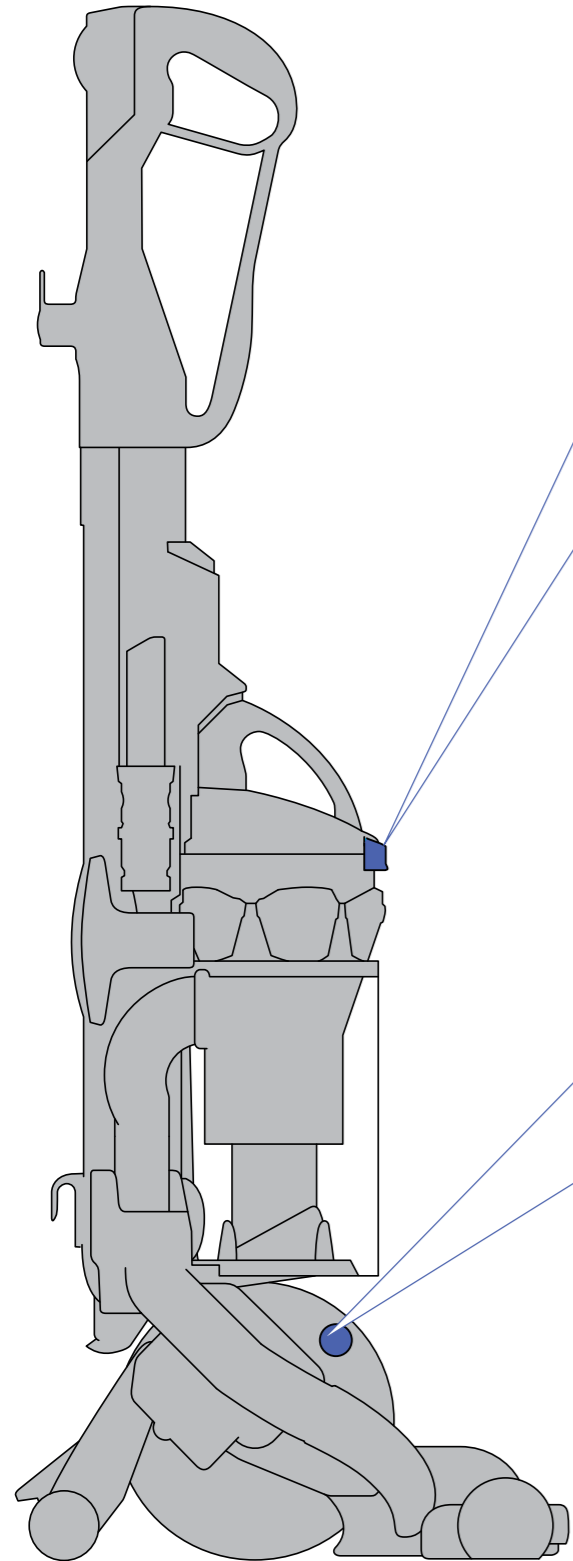

A Filter

B Filter

Rinse and shake filter under tap. Turn over and tap very firmly to remove motor emissions. Repeat until water runs clear.



IMPORTANT!

WASH FILTERS



Wash your filter with cold water regularly or as required.

Register for a filter wash reminder by email (Australia only):
customercare@dyson.com.au



Dyson Customer Care

If you have a question about your Dyson vacuum cleaner, call the Dyson Customer Care Helpline with your serial number and details of where and when you bought the vacuum cleaner, or contact us via the Dyson website. The serial number can be found on the main body of the vacuum cleaner behind the clear bin.

AU Dyson Customer Care
customercare@dyson.com.au
1800 239 766
Dyson Appliances (Aust) Pty Ltd.,
PO Box 2835,
Taren Point, NSW 2229
Australia
www.dyson.com.au

NZ Dyson Customer Care
dyson@averyrobinson.co.nz
0800 397 667
Avery Robinson Ltd.,
Unit F, 151D Marua Road,
Ellerslie, Auckland, 1051
New Zealand
www.dyson.co.nz

SG Dyson Customer Care
singapore@dyson.com
7000 435 7546
Service @ Home Pte. Ltd.,
2 Leng Kee Road,
#04-09A Thye Hong Centre,
Singapore 159086
www.dyson.com.sg

ID Dyson Customer Care
service@higienis.com
021 707 39766
PT. Higienis Indonesia,
Permata Plaza Top Floor, TF-04,
Jl. M. H. Thamrin Kav. 57,
Jakarta 10350
Indonesia
www.dyson.co.id

dyson

QUESTIONNAIRE

Please take a few moments to answer our questions.
They will help us develop new products for the future.

- This vacuum cleaner is...
 - My first vacuum cleaner (please go to question 3)
 - A replacement vacuum cleaner
 - An additional vacuum cleaner
- Which brand of vacuum cleaner are you replacing or adding to?
 - Dyson
 - Hoover
 - Miele
 - Vax
 - Volta
 - Other, please specify
 - Electrolux
 - LG
 - Nilfisk
 - Wertheim
- Why did you choose to buy a Dyson vacuum cleaner?
(Please rank in order, 1-5. 1 being the most important).
 - Dyson reputation
 - Good for pet hair pick-up
 - No loss of suction
 - Previous experience of Dyson
 - HEPA filter/benefit for asthma and allergy sufferers
 - Features
 - Price/special offer
 - Wanted a bagless cleaner
 - Compact and easy to store
 - Store staff recommendation
 - Picks up more dust than others
 - Latest model/technology
 - Reliability/quality
 - Friend/family recommendation
 - Other
- Where did you first hear about Dyson?
 - From friends and family
 - Saw it on the internet
 - From TV/a magazine advert
 - Saw it in a store catalogue
 - Saw it in a store
 - Recommended by salesperson
- Where did you look for additional information?
 - Dyson website
 - Online reviews and forums
 - Talked to retail staff
 - Retail catalogue
 - Didn't do any additional research
- Do you own other Dyson products?
 - Handheld
 - Vacuum cleaner
 - No
 - Fan
 - Handstick
- What is your average household income?
 - Less than \$45,000
 - Between \$45,000 – \$74,999
 - Between \$75,000 – \$100,000
 - Over \$100,000
- Do you have any household pets?
 - Dog
 - No
 - Cat
 - Other
- Does anyone in your household suffer from any of the following?
 - Asthma
 - No
 - Allergies
- To which age group do you belong?
 - 16 – 24
 - 35 – 44
 - 55 – 64
 - 25 – 34
 - 45 – 54
 - 65+
- Would you recommend a Dyson vacuum cleaner to your family and friends?
 - Yes
 - No
- Do you have children?
 - Pre-school
 - Aged +17 years
 - Pregnant
 - Aged 5-17 years
 - Children no longer at home
 - No children
- Which best describes your house?
(Tick one from each column).
 - Own house
 - Rented house
 - Own apartment/villa
 - Rented apartment/villa
 - Share accommodation
 - Live with parents
 - Up to 2 beds
 - 3-4 beds
 - More than 4 beds

THANK YOU FOR YOUR TIME

www.dyson.com



dyson GUARANTEE FORM

2 year guarantee – plus option to extend to 5 years.

Section 1: Dyson 2 year guarantee

Please complete Section 1 to register as a Dyson machine owner, and return it in the envelope provided. Alternatively, register online and New Zealand only).

Serial number			
Date of purchase	<input type="text"/> / <input type="text"/> / <input type="text"/>	Country of purchase	AU <input type="checkbox"/> NZ <input type="checkbox"/> SG <input type="checkbox"/> ID <input type="checkbox"/>
Store of purchase	<input type="text"/>		
Did you purchase an extended warranty from the retailer?	Yes <input type="checkbox"/>	No	<input type="checkbox"/>
If yes, for what additional period?	1 year <input type="checkbox"/>	2 years <input type="checkbox"/>	3 years <input type="checkbox"/>

Title	First name	Surname
<input type="text"/>	<input type="text"/>	<input type="text"/>
Address		
<input type="text"/>		
<input type="text"/>		
<input type="text"/>		
<input type="text"/>		
Postcode		
<input type="text"/>		
email	Contact number	
<input type="text"/>	<input type="text"/>	

Privacy Act

Dyson may use this information for future marketing and research purposes (including sending commercial electronic messages) and may disclose it to third parties for the purposes of providing the services you have requested or to our business partners or professional advisers. If you wish to access your personal information or see our full privacy policy, please contact us at customer@dyson.com.au

If you do not wish to receive marketing information by these methods from Dyson please tick this box.

REGISTER ONLINE

Visit our website to register your Dyson full parts and labour guarantee online (Australia and New Zealand only).

AU: www.dyson.com.au/register

NZ: www.dyson.co.nz/register

REGISTER BY MAIL

Complete and return the form to Dyson in the envelope supplied.

REGISTER BY PHONE

Call our dedicated Helpline.

AU 1800 239 766 NZ 0800 397 667
SG 7000 435 7546 ID 021 707 39766

Section 2: Dyson 2+3 year guarantee

Increase your Dyson 2 year guarantee cover to 5 years when you purchase an extended guarantee from Dyson (Australia only). This option is just AU\$89.00. Dyson is committed to providing the best Aftersales Service, which is why we offer the option to extend your Dyson 2 year guarantee to 5 years. The terms of the Dyson 2 year guarantee on page 9 of this Dyson Operating Manual will apply to the Dyson extended guarantee. The Dyson extended guarantee is underwritten by Dyson Appliances (Aust) Pty Ltd. To purchase, just complete the fields below. Send both sections to us, together with your cheque/money order or credit card details, within 2 years of your vacuum cleaner purchase. Offer to purchase the Dyson extended guarantee is only available within 2 years of customers purchasing their vacuum cleaner. Offer not available to customers who have purchased an extended warranty from a retailer. The Dyson extended guarantee provides benefits which are additional to, and do not affect, your statutory rights and remedies as a consumer. If you decide not to extend your Dyson 2 year guarantee, you may have statutory rights and remedies available to you as a consumer.

Cheque/money order made payable to: Dyson Appliances.

Credit card Mastercard Visa

Card Number / / /

Expiry Date M/M Y/Y

Declaration

I hereby apply for the Dyson vacuum cleaner extended guarantee in accordance with the terms and conditions of your plan. I confirm the vacuum cleaner is in good working order and used for domestic purposes only and declare that the details on this proposal are true and complete to the best of my knowledge and belief.

Signature

Date / /

WARNING Any false statement may render this plan invalid

Free Manuals Download Website

<http://myh66.com>

<http://usermanuals.us>

<http://www.somanuals.com>

<http://www.4manuals.cc>

<http://www.manual-lib.com>

<http://www.404manual.com>

<http://www.luxmanual.com>

<http://aubethermostatmanual.com>

Golf course search by state

<http://golfingnear.com>

Email search by domain

<http://emailbydomain.com>

Auto manuals search

<http://auto.somanuals.com>

TV manuals search

<http://tv.somanuals.com>