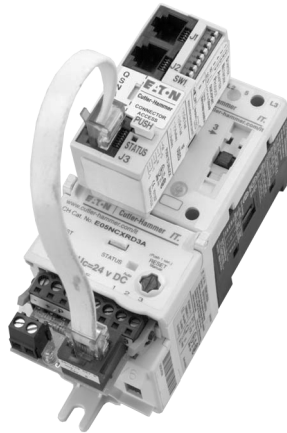

 **Intelligent Technologies****QCPort Starter Network Adapter Product
(QSNAP)****Installation and User Manual**

Important Notice – Please Read

The product discussed in this literature is subject to terms and conditions outlined in appropriate Eaton's Cutler-Hammer selling policies. The sole source governing the rights and remedies of any purchaser of this equipment is the relevant Eaton's Cutler-Hammer selling policy.

NO WARRANTIES, EXPRESS OR IMPLIED, INCLUDING WARRANTIES OF FITNESS FOR A PARTICULAR PURPOSE OR MERCHANTABILITY, OR WARRANTIES ARISING FROM COURSE OF DEALING OR USAGE OF TRADE, ARE MADE REGARDING THE INFORMATION, RECOMMENDATIONS AND DESCRIPTIONS CONTAINED HEREIN. In no event will Eaton's Cutler-Hammer be responsible to the purchaser or user in contract, in tort (including negligence), strict liability or otherwise for any special, indirect, incidental or consequential damage or loss whatsoever, including but not limited to damage or loss of use of equipment, plant or power system, cost of capital, loss of power, additional expenses in the use of existing power facilities, or claims against the purchaser or user by its customers resulting from the use of the information, recommendations and descriptions contained herein.

Cover Photo: QSNAP on IT. E101 Starter

February 2002

Table of Contents

PRODUCT OVERVIEW	
Description	1
Features and Benefits	2
Safety	3
Environmental Ratings	4
Approvals/Certifications	4
Catalog Numbering System	4
PHYSICAL FEATURES	
Physical Description	5
Dimensions	5
Power Source	6
OPERATION	
"Out of Box" Operation	8
Typical Application	9
Enhanced Features	10
Input/Output Data	11
Input Data	11
Output Data	12
Status LED	13
Truth Table	13
CONFIGURATION	
Using CH Studio	14
INSTALLATION	
Set the Group ID	15
SW1 Settings	16
Mount the IT QSNAP to the Starter	16
Wire the IT QSNAP to the Starter	18
Connect the QSNAP to QCPort	19
TROUBLESHOOTING AND MAINTENANCE	
Renewal Parts	20
Troubleshooting	20
APPENDIX A: QSNAP PARAMETERS	21
INTELLIGENT TECHNOLOGIES (IT) PUBLICATIONS AND SUPPORT	23

List of Figures

Figure 1: QSNAP Features	5
Figure 2: QSNAP Dimensions, mm [in]	5
Figure 3: Starter Interface Connection	6
Figure 4: Typical QSNAP Application	9
Figure 5: Group ID Setting	15
Figure 6: QSNAP with 54 mm IT. Starter	16
Figure 7: QSNAP Alignment and Mounting	17
Figure 8: QSNAP Removal	17
Figure 9: Jumper and RJ-45 Plug	18
Figure 10: Jumper Installation	18
Figure 11: QCPort Connection	19
Figure 12: QCPort Wiring Diagram	19

List of Tables

Table 1: QSNAP Electromechanical Starter Connectivity Table	1
Table 2: QSNAP S751 Connectivity Table	1
Table 3: Environmental Ratings	4
Table 4: Approvals/Certifications	4
Table 5: Power Requirements	6
Table 6: Default Input Data from QSNAP	8
Table 7: Default Output Data to QSNAP	8
Table 8: Standard Features	10
Table 9: Enhanced Features	10
Table 10: Input Assembly Data Definitions	11
Table 11: Default Input Data	12
Table 12: Default Output Data	12
Table 13: Output Assembly Data Definitions	12
Table 14: Status LED	13
Table 15: QSNAP Truth Table	13
Table 16: SW1 Settings	16
Table 17: Starter Size/Available Auxiliary Locations on Mounted QSNAP	16
Table 18: Terminal Block Wiring	18
Table 19: QSNAP Renewal Parts	20
Table 20: Troubleshooting	20
Table 21: Configuration Parameters	21
Table 22: Data Parameters	22
Table 23: IT. Publications	23

February 2002

Product Overview

Description

Cutler-Hammer Intelligent Technologies (IT) QSNAP (QCPort Starter Network Adapter Product) by Eaton Corporation is the result of a substantive engineering and marketing effort, involving extensive customer input. This product has greatly increased functionality of the Eaton's Cutler-Hammer Intelligent Technologies (IT) Electromechanical Starter with the addition of enhanced features, such as jam, stall and underload. This single front-mount device is a single QCPort™ (Quick Connect Port) device providing control and monitoring of Intelligent Technologies (IT) Electromechanical Starter application.

The QSNAP product line provides communication capability to the following Intelligent Technologies (IT) Electromechanical Starters.

Table 1: QSNAP Electromechanical Starter Connectivity Table

Amperage Rating	IEC E101 E501	Frame Size	NEMA N101 N501	Frame Size
18 Amp	B	45 mm	00	45 mm
25 Amp			0	
32 Amp				
40 Amp	C	54 mm	1	54 mm
50 Amp				
65 Amp	D	76 mm	2	76 mm
85 Amp				
100 Amp				
125 Amp	E	105 mm	3	105 mm
160 Amp			4	
200 Amp				
250 Amp	F	140 mm	5	140 mm
315 Amp				
400 Amp				

Table 2: QSNAP S751 Connectivity Table

S751
All

This manual specifically addresses the QCPort Starter Network Adapter Product (QSNAP).

For further information on the IT family of devices, visit our Web site at: www.cutler-hammer.eaton.com/it

Notice

Because the IT Starters use 24V DC for control and power, the QSNAP can only be applied with the IT family of starters.

Features and Benefits

The *IT* QSNAP includes the following significant features:

- Communication to QCPort consuming a single QCPort ID
- Control of non-reversing and reversing Eaton's Cutler-Hammer Intelligent Technologies (*IT*) Electromechanical Starters
- Monitoring of non-reversing and reversing Eaton's Cutler-Hammer Intelligent Technologies (*IT*) Electromechanical Starters
- Direct mounting to the front of Eaton's Cutler-Hammer Intelligent Technologies (*IT*) Electromechanical Starter
- Connection to an auxiliary ground fault detector
- Sensing of the second contactor
- Manually set Group ID; configuration using a software application is not required for normal operation
- Enhanced features, such as jam and stall detection and nuisance trip avoidance
- Warning levels that are user-settable
- Settable current threshold alarm

February 2002

Safety

The following safety statements relate to the installation, setup and operation of Eaton's Cutler-Hammer *IT*. QSNAP and Starter.

Notice

Make sure you read and understand the installation procedures in this manual **before** you attempt to operate or set up the equipment.

WARNING

This instruction manual should be used for proper installation, setup and operation of the *IT*. QSNAP. Improperly installing and maintaining this product can result in serious personal injury or property damage. Before attempting installation, setup or operation, read and understand this entire manual.

WARNING

Hazardous voltage can cause electric shock and burns. Always disconnect power before proceeding with any work on this product.

CAUTION

Only apply 24V DC to the QSNAP power terminals. Use of any other voltage may result in personal injury, property damage and damage to the *IT*. QSNAP.

WARNING

To provide continued protection against fire or shock hazard, the complete *IT*. QSNAP must be replaced if it becomes inoperative.

Environmental Ratings

The following environmental ratings apply to the QSNAP.

Table 3: Environmental Ratings

Category	Description	Specification	
Transportation	Temperature	-50°C to 80°C [-58°F to 176°F]	
	Humidity	95% non-condensing	
Storage	Temperature	-50°C to 80°C [-58°F to 176°F]	
	Humidity	95% non-condensing	
Operating	Temperature	-30°C to 55°C [-22°F to 131°F]	
	Humidity	95% non-condensing	
	Altitude	Above 2000 meters [6600 feet] consult factory	
	Shock	15 g's half-wave sinusoidal 11 msecs	
	Vibration		5 – 57.5 Hz (100 – 17 msecs) @ 0.3 mm SA
			57.5 – 150 Hz (17 – 6.7 msecs) @ 0.35 mm SA
Enclosure		IP20	

Approvals/Certifications

The following approvals and certifications apply to the QSNAP.

Table 4: Approvals/Certifications

Standard	Approval/Certification
UL	UL508
CE	
CSA	CSAC22.2 No. 14-95

Catalog Numbering System

There is only one catalog number for QCPort connection to Eaton's Cutler-Hammer Intelligent Technologies (IT) Electromechanical Starters. These starters include those listed in **Table 1** on **Page 1**.

The catalog number is QSNAP.

This part number includes the QSNAP and the starter interface board that connects the starter and the QSNAP.

Note: When ordering QSNAP for Full Voltage Reversing, consult factory for the QSNAP Auxiliary contact and jumper catalog numbers.

Note: When ordering a ground fault detector, consult factory for catalog number.

February 2002

Physical Features

Physical Description

Figure 1 illustrates the front and back of the IT QSNAP and its various features.

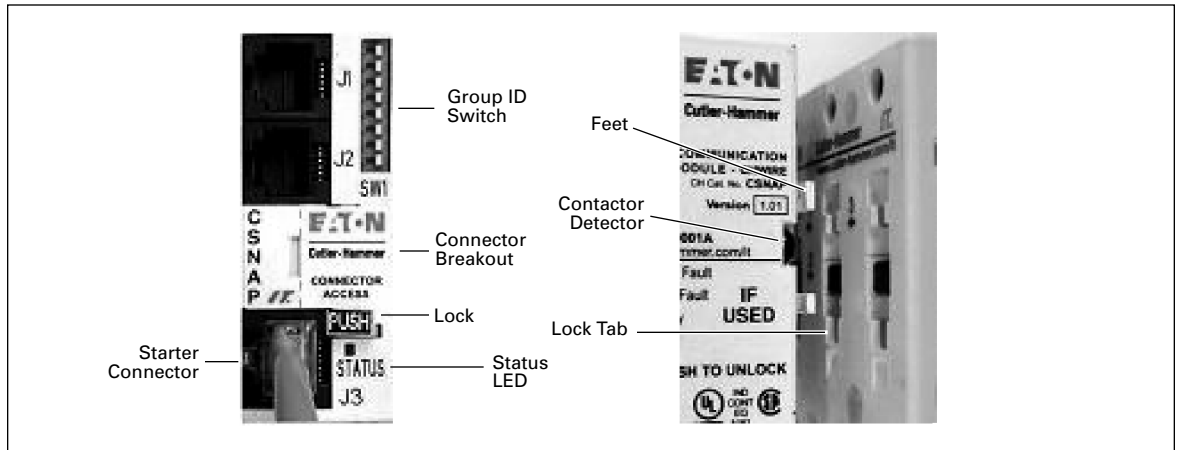

Figure 1: QSNAP Features

Dimensions

Figure 2 illustrates the dimensions of the IT QSNAP.

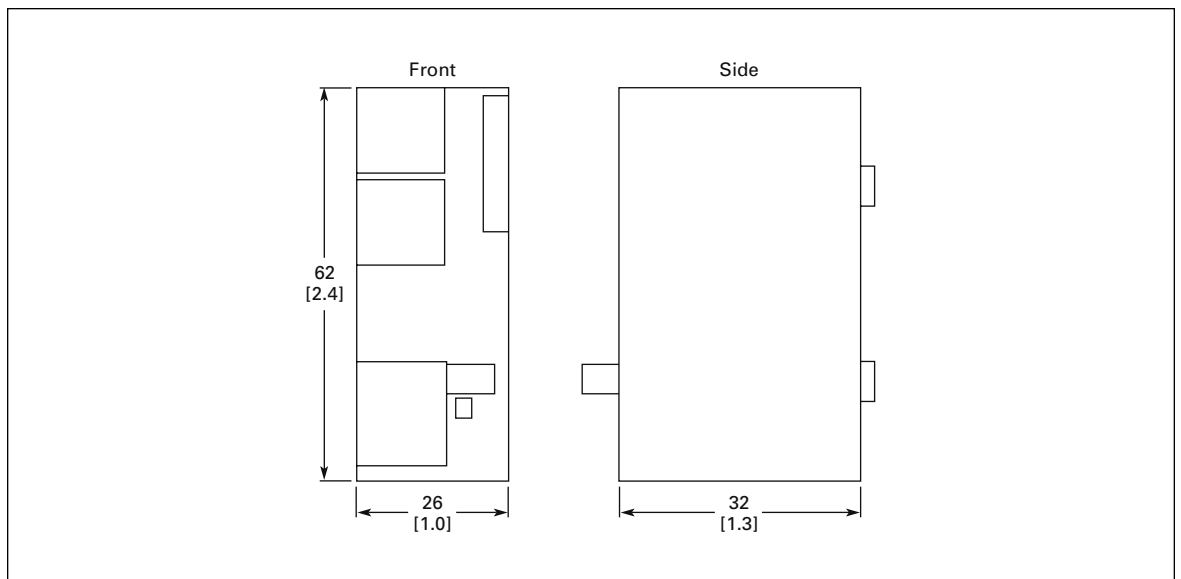

Figure 2: QSNAP Dimensions, mm [in]

Power Source

The IT. QSNAP is designed for use with 24V DC power. The QSNAP uses power from two sources when operating properly; these sources are the QCPort subnet and the Eaton's Cutler-Hammer Intelligent Technologies (IT.) Electromechanical Starter. This allows the QSNAP to detect and communicate to the user that the IT. starter does not have 24V DC power, signaling a fault or an E-Stop.

The main power that powers the communication is from QCPort, as illustrated in **Table 5**. Some power is required from the starter for communication to be present between the Intelligent Technologies (IT.) Electromechanical Starter and the QSNAP.

The power for the IT. starter must be connected to the starter terminal.

Table 5: Power Requirements

Current Source	Load
QCPort	TBD
IT. Starter	TBD

When a power supply is chosen for QCPort, take into account the load on QCPort. When a power supply is chosen for the starter(s), size it for the load of the starter(s) using the *IT. Contactor and Starter User Manual* (Publication No. 49400). Refer to the *IT. QCPort System Install and Planning Guide* (Publication No. MN05001002E) for more information on how to size the power supply for the QCPort system.

The power for the Eaton's Cutler-Hammer Intelligent Technologies (IT.) Electromechanical Starter must be connected to the Intelligent Technologies (IT.) Electromechanical Starter terminal, as illustrated in **Figure 3**.

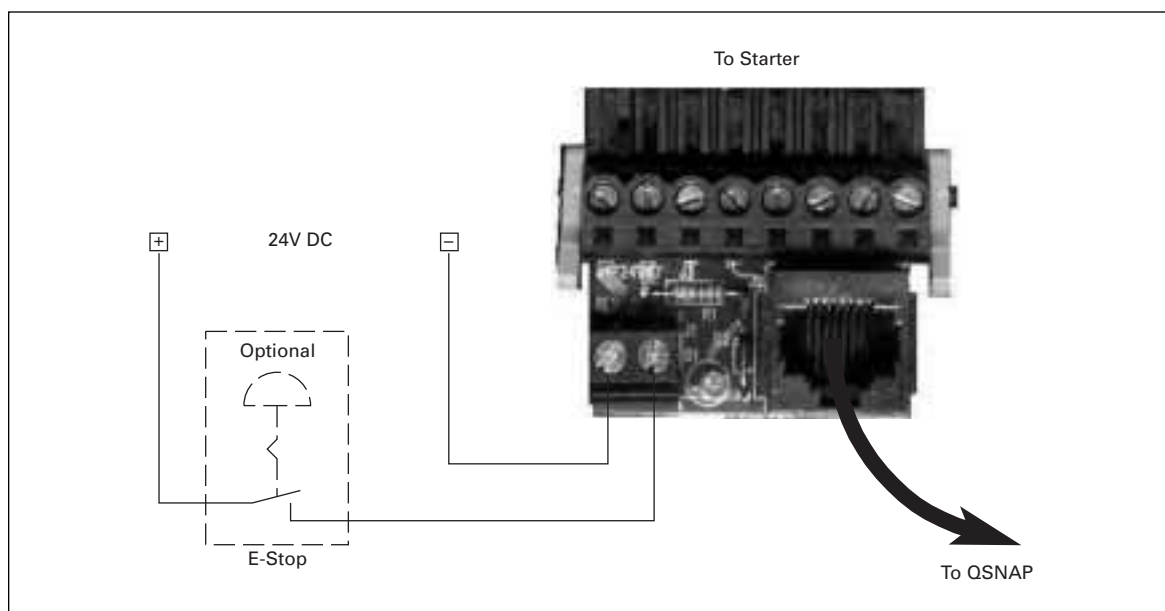

Figure 3: Starter Interface Connection

February 2002

 **CAUTION**

Only apply 24V DC to the QSNAP. Use of any other voltage may result in personal injury, property damage and damage to the QSNAP.

Operation

This section provides details about the following features and aspects of QSNAP operation:

- “Out of box” operation
- Typical application
- Enhanced features
- Input/output data
- Status LED
- Truth table

“Out of Box” Operation

When the QSNAP is properly installed and has a properly configured Group ID, as per the “Installation” section, the following default data lists will be presented to the system for use by a gateway.

For further information on the meaning of the terms in the assemblies, see the “Enhanced Features” section on **Page 10**.

Table 6: Default Input Data from QSNAP

Bit 7	Bit 6	Bit 5	Bit 4	Bit 3	Bit 2	Bit 1	Bit 0	
3-Phase Average RMS Current LSB								Byte 0
3-Phase Average RMS Current								Byte 1
3-Phase Average RMS Current								Byte 2
3-Phase Average RMS Current MSB								Byte 3
% Thermal Capacity LSB								Byte 4
% Thermal Capacity MSB								Byte 5
Fault/Warning Codes LSB								Byte 6
Fault/Warning Codes MSB								Byte 7
Reserved	Warning	Faulted	Local Control	Resetting	Permissive	Running 2	Running 1	Byte 8

Table 7: Default Output Data to QSNAP

Bit 7	Bit 6	Bit 5	Bit 4	Bit 3	Bit 2	Bit 1	Bit 0	
Reserved	Reserved	Local Control	Local/Remote	Fault Reset	Permissive	Run 2	Run 1	Byte 8

February 2002

Typical Application

The following figure illustrates a typical QSNAP application, where a single QSNAP is connected to one motor controller and where the motor controllers are distributed throughout QCPort. The subnet is then being controlled by a PC or PLC, which scans the D77D-DNA DeviceNet Adapter, retrieving the QSNAP's control and monitoring information.

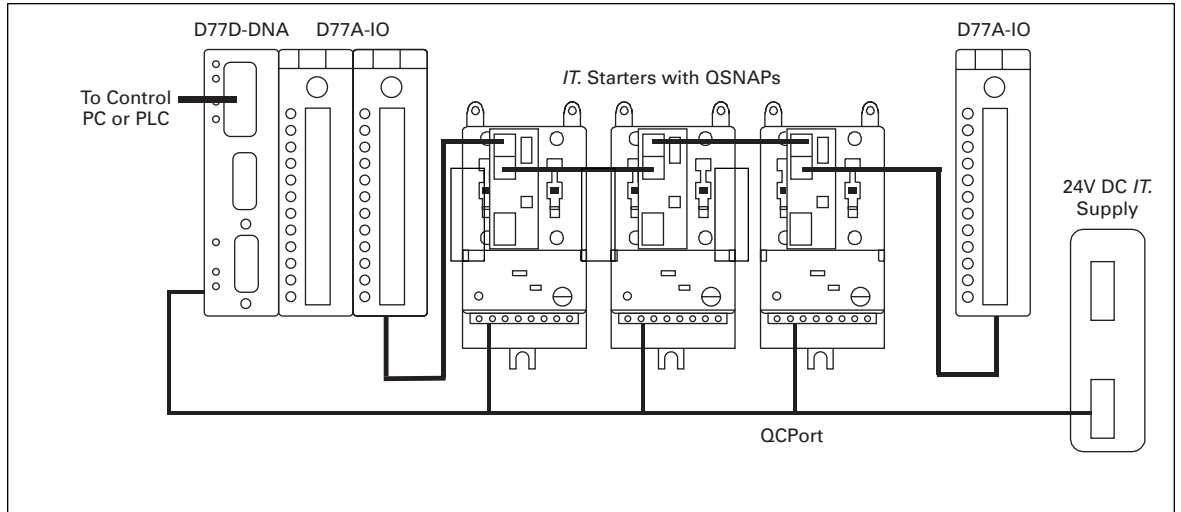

Figure 4: Typical QSNAP Application

Note: Such an application has more devices on QCPort than are shown in this illustration, such as drives and user interface units.

Enhanced Features

The QSNAP offers a variety of enhanced features, including: settable warnings, current threshold warning, underload warning and reset. To help diagnose an application, a fault queue is provided to view the last five faults.

Refer to the following two tables for definitions of the QSNAP Enhanced Features and Threshold Features.

Table 8: Standard Features

Fault	Definition
Phase Current Unbalance/Phase Loss	A phase current unbalance trip will occur if one or two of the line currents are 40 – 60% or less of the remaining line(s) for longer than 10 seconds. A phase loss trip will occur with a load current of at least 75% of the minimum FLA if one of the two input line voltages is lost, with the line current going to zero for longer than 10 seconds.
Thermal Overload	While the motor is running and depending on the FLA and trip class settings, when the FLA is exceeded for a period of time (depending on the trip class setting), a thermal overload trip will occur. For more information on this feature, see the <i>IT. Contactor and Starter User Manual</i> (Publication No. 49400).

Table 9: Enhanced Features

Fault	Definition
Ground Fault	With the addition of a Ground Fault module, the QSNAP will trip when the module detects a ground fault. To set the level of the trip, a setting is adjusted on the Ground Fault Module. The Ground Fault Module is connected to the QSNAP through the Auxiliary opening on the face of the QSNAP.
Underload Warning	While the motor is running, a warning will be activated when the current falls below a user settable % of FLA.
Current Threshold Warning	While the motor is running, a warning will be activated when the current rises above a user settable % of FLA.

Note: The threshold values for Thermal Overload and Phase Current Unbalance can not be modified.

February 2002

Input/Output Data

The QSNAP offers a standard data list (shown below) for default operation. The list is configurable with data contained within **Table 21** in **Appendix A: QSNAP Parameters**, using the CH Studio application.

Input Data

Use **Tables 10** and **11** when setting up the QSNAP input data.

Table 10: Input Assembly Data Definitions

Data	Description
Faulted/Trip	The motor controller is faulted or tripped
Warning	The motor controller has a warning of an impending trip
Running 1	The first motor controller is running
Running 2	The second motor controller is running
Permissive	The motor controller run/stop permissive
Resetting	Motor controller is in the process of resetting a fault
Thermal Capacity	% thermal capacity of the motor from 0 to 100%
RMS Average Current	Average RMS current of the motor (0.000A)
Fault Codes and Warning Codes	Valid fault and warning codes are:
	0 No Fault
	1 General Fault
	2 Firmware Fault
	3 Interdevice Communication Fault
	4 Control Voltage Low Fault
	5 Control Device Overtemperature Fault
	6 Motor Phase Loss Fault
	7 Motor Phase Imbalance Fault
	8 Motor Ground Fault
	9 Motor Underload Fault
	10 Motor Overcurrent Fault
	13 Motor Bypass Failure Fault
	14 Motor Thermal Pile Fault
	15 Control Device Test Fault
	40000 Current Threshold Warning
	40001 Underload Warning
40002 Control Device Overtemperature Warning	
40003 Overload Warning	

Table 11: Default Input Data

Bit 7	Bit 6	Bit 5	Bit 4	Bit 3	Bit 2	Bit 1	Bit 0	
3-Phase Average RMS Current LSB								Byte 0
3-Phase Average RMS Current								Byte 1
3-Phase Average RMS Current								Byte 2
3-Phase Average RMS Current MSB								Byte 3
% Thermal Capacity LSB								Byte 4
% Thermal Capacity MSB								Byte 5
Fault/Warning Codes LSB								Byte 6
Fault/Warning Codes MSB								Byte 7
Reserved	Warning	Faulted	Local Control	Resetting	Permissive	Running 2	Running 1	Byte 8

Output Data

Use **Tables 12** and **13** when setting up the QSNAP output data.

Table 12: Default Output Data

Bit 7	Bit 6	Bit 5	Bit 4	Bit 3	Bit 2	Bit 1	Bit 0	
Reserved	Reserved	Local Control	Local / Remote	Fault Reset	Permissive	Run 2	Run 1	Byte 8

Table 13: Output Assembly Data Definitions

Data	Description
Run 1	Energize the first starter when Permissive is 1
Run 2	Energize the second starter when Permissive is 1
Fault Reset	Reset the fault
Permissive	Starter Permissive, 0 – Stops the starter, 1 – Enables to run the starter





February 2002

Status LED

The status LED is located on the lower right of the QSNAP as pictured in **Figure 1: QSNAP Features**. The LED's status changes depending on the state of the QSNAP.

The following table lists the *IT*. QSNAP LED statuses and describes the meaning of each state.

Table 14: Status LED

State	LED Behavior
No Power	OFF
Power-Up Routine	OFF – CRC corrupt
Waiting for a member ID, power-up OK (mostly off)	
Received a member ID, off-line (slow blink)	
On-line (mostly on)	
Faulted (fast blink)	
Identify device (burst)	

Truth Table

Table 15: QSNAP Truth Table

Old State	Fieldbus Inputs			Event	New State	Action	
	Run 1	Run 2	Reset				
FAULTED	–	–	1	RESET	OFF	FAULT = 0	READY = 1
OFF	0	0	–	NONE	OFF	NONE	
OFF	1	0	–	RUN 1	RUNNING 1	RUNNING 1 = 0	
OFF	0	1	–	RUN 2	RUNNING 2	RUNNING 2 = 0	
RUNNING 1	1	1	–	RUN 2	RUNNING 1	NONE	
RUNNING 2	1	1	–	RUN 1	RUNNING 2	NONE	
RUNNING 1	1	1	–	RUN 1 removed	RUNNING 2	RUNNING 1 = 0, RUNNING 2 = 1	
RUNNING 2	1	1	–	RUN 2 removed	RUNNING 1	RUNNING 1 = 1, RUNNING 2 = 0	
RUNNING 1	1	0	–	FAULT	OFF	RUNNING 1 = 0	READY = 0
RUNNING 2	0	1	–	FAULT	OFF	RUNNING 2 = 0	READY = 0
RUNNING 1	1	0	–	WARNING	RUNNING 1	RUNNING 1 = 1	WARNING = 1
RUNNING 2	0	1	–	WARNING	RUNNING 2	RUNNING 2 = 1	WARNING = 1

– = state not important

1 = state true (energized)

0 = state false (de-energized)

WARNING = Running Current > FLA but not tripped

RUNNING 1 = Run/FWD/SLOW

RUNNING 2 = REV/FAST

FAULT = GND FLT and/or OL TRIP

Configuration

The only configuration that is necessary for normal operation of the QSNAP is setting the Group ID and SW1 positions A and B, as described in the "Installation" section. However, the QSNAP offers a variety of enhanced features. When these features are required, use the CH Studio application or a tool that can read an EDS file to perform the configuration.

Using CH Studio

The CH Studio software application is designed for programming and configuring industrial automation systems. The application simplifies the monitoring and configuration of entire networks as well as the enhanced features of individual *IT.* communicating devices within those networks.

CH Studio takes advantage of the Windows graphical interface to present a suite of tools that is easy to learn and efficient to use, while meeting the requirements for developing complex network configurations.

CH Studio performs the following configuration functions for DeviceNet and QCPort networks:

- Discover network devices
- Display device properties
- Monitor and configure network devices
- Save existing network configurations
- Configure networks off-line
- Configure devices off-line

February 2002

Installation

Set the Group ID

The Group ID refers to the logical QCPort group to which the QSNAP belongs. For further information on the explanation of Group ID and the system configuration, see the *IT. QCPort System Install and Planning Guide* (Publication No. MN05001002E).

The Group ID and SW1 A and B DIP switches are located at the upper right of the QSNAP, as illustrated in **Figure 5: Group ID Setting**. CH Studio can view the settings for the Group ID, but cannot be used to modify them.

Move the DIP switches to **ON/OFF** positions to create the Group ID. Moving a DIP switch to the right is **ON** and moving the switch to the left is **OFF**. The Group ID is in binary with the major units numbered to the right of the switch on the side label. Adding up the major units set to ON determines the Group ID of the QSNAP.

Example: To set the Group ID to 25, start from the top (or 32) and set the switches to OFF, ON, ON, OFF, OFF, OFF, ON (16+8+1=25).

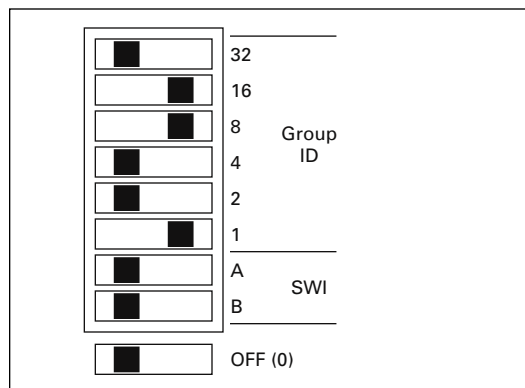

Figure 5: Group ID Setting

When a gateway is present and presenting the QSNAP as remote IO, each device on the QCPort must have a unique Group ID. If any two like QCPort devices have the same Group ID, those devices will go off-line. Refer to the appropriate gateway install manual for information on the data packet construction for that fieldbus (*IT. DeviceNet Adapter Installation and User Manual*, Publication No. MN05004002E).

Once the Group ID is set, a power cycle is not required; after five seconds of inactivity of the switches, the change takes effect. The Status LED indicates if the QSNAP is properly configured; the LED is located on the lower right of the QSNAP, as illustrated in **Figure 6: QSNAP with 54 mm IT Starter**. For more information on the LED, see "Operation."

SW1 Settings

SW1 is used to set the existence of the second Aux contact and the external ground fault.

Table 16: SW1 Settings

SW1 Position	Event
A	0 = no second Aux installed, 1 = second Aux installed
B	0 = no ground fault installed, 1 = ground fault installed

Mount the IT QSNAP to the Starter

The IT QSNAP is designed to be installed in the auxiliary contact locations of the IT family of starters as illustrated in **Figure 6**. On all starters, one or more auxiliaries can be used along with the QSNAP. **Table 17** lists starters and indicates the number of available auxiliary locations for each.

Table 17: Starter Size/Available Auxiliary Locations on Mounted QSNAP

Starter Frame Size (mm)	Number of Available Auxiliary Locations when Center Mounted
45	1 single
54	1 single or 1 dual
76	2 single or 2 dual
105	2 single or 2 dual
140	2 single or 2 dual

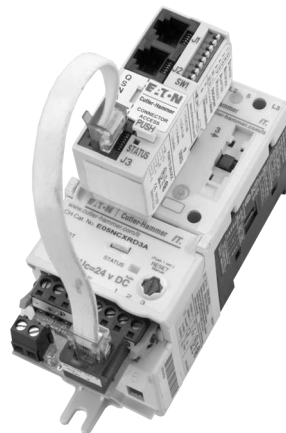

**Figure 6: QSNAP with
54 mm IT Starter**

February 2002

Use the following steps and the illustration in **Figure 7** to mount the QSNAP.

1. Align both the QSNAP feet with the auxiliary contact mounting slots on the starter, as illustrated in the figure.

Recommendation: Use the middle mounting auxiliary contact on the contact block when mounting the QSNAP.

2. When the QSNAP is aligned, insert the feet into the detents and slide the QSNAP towards the overload until a “click” is heard. This ensures that the QSNAP is mounted securely to the starter.

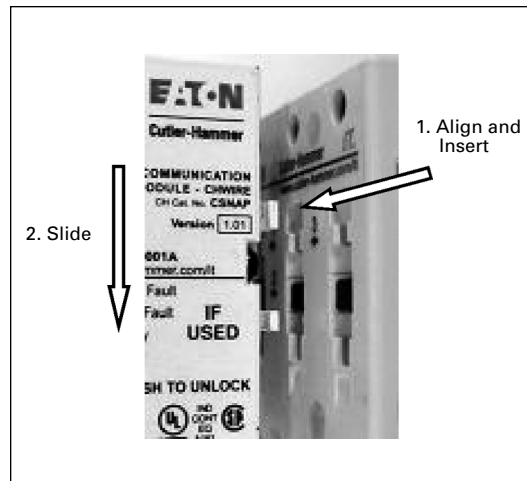

Figure 7: QSNAP Alignment and Mounting

Note: To remove the QSNAP, press the “PUSH” tab protruding from the QSNAP while sliding the QSNAP up and pulling away from the contactor block, as illustrated in **Figure 8**.

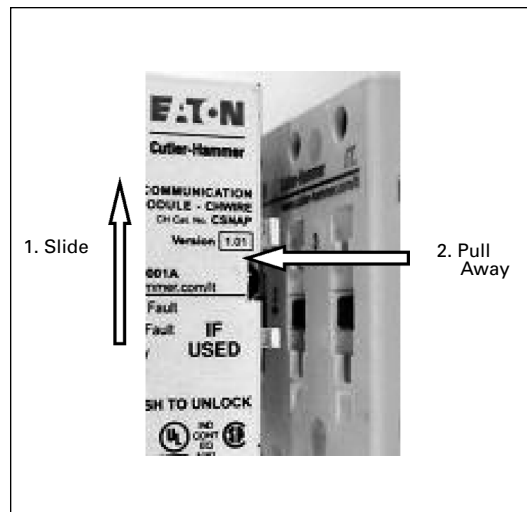

Figure 8: QSNAP Removal

Wire the IT. QSNAP to the Starter

The QSNAP is connected to the *IT.* starter using a factory-provided jumper with an RJ-45 plug on one end and a pigtail on the other. The pigtail is color coded to facilitate accurate connection to the overload terminal block. Refer to the following figure and table when wiring the terminal block.

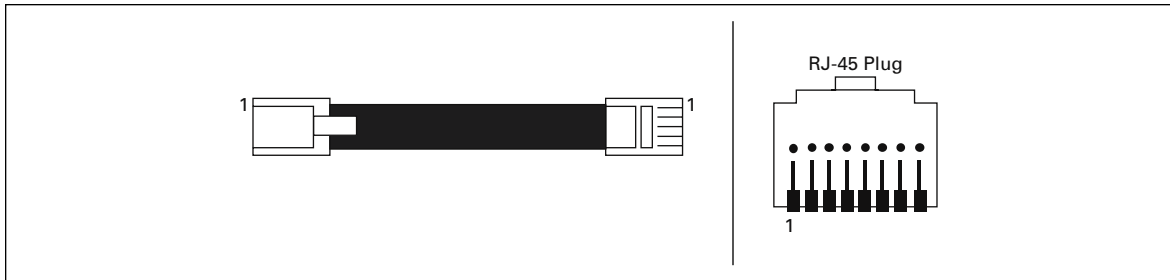

Figure 9: Jumper and RJ-45 Plug

Table 18: Terminal Block Wiring

Starter	RJ-45
GND	1
+24	2
P	3
F	4
R	5
1	6
2	7
3	8

Use the following steps and illustrations to install the jumper.

1. Once the jumper is wired, insert the terminal block into the overload and the RJ-45 connector into J3 on the QSNAP as illustrated in **Figure 10: Jumper Installation**.

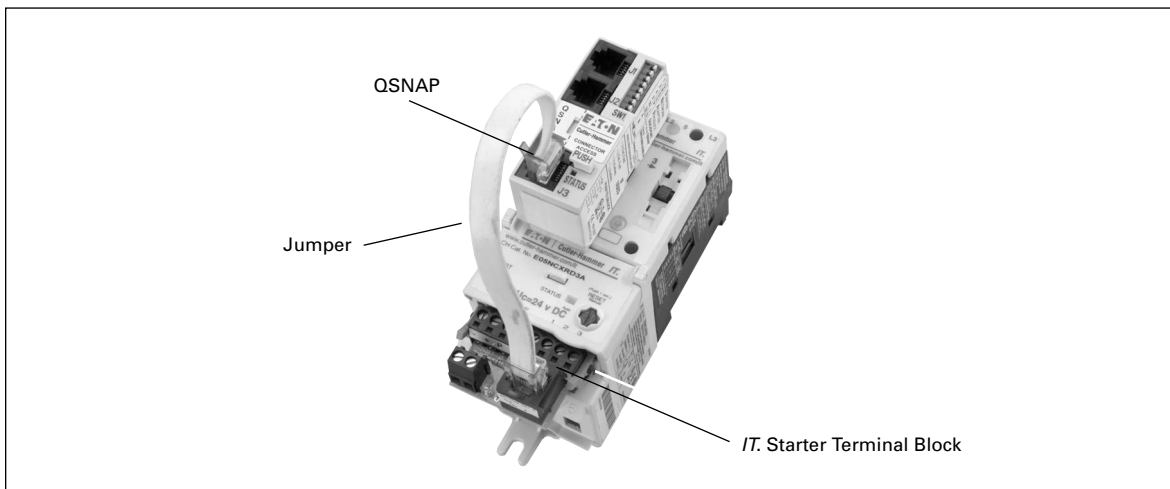

Figure 10: Jumper Installation

February 2002

2. To lock the starter interface to the overload, rotate the orange locking tabs until the tab is locked into the slots in the overload. Use **Figure 11** for information on which way to rotate the locking tabs.

Note: Refer to the *IT. Contactor and Starter User Manual* (Publication No. 49400) for more information on locking and unlocking the terminal block to the starter.

Connect the QSNAP to QCPort

The connection to QCPort consists of using the QCPort interconnect jumper from the second port of the upstream device and connecting it to J1 on the QSNAP. The downstream QCPort device then connects to J2 on the QSNAP as in **Figure 11: QCPort Connection**. Use the following wiring diagram and illustration to connect the QSNAP to QCPort.



Figure 11: QCPort Connection

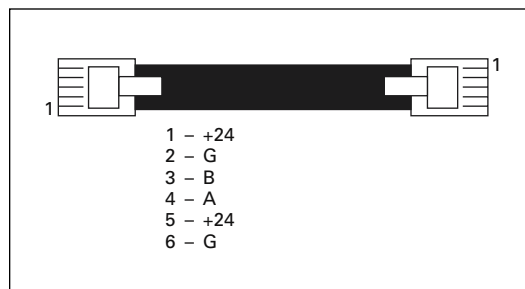

Figure 12: QCPort Wiring Diagram

Use one of the pre-manufactured cables for connecting between QCPort devices. If a custom cable is to be made, follow the guidelines for cable specifications and connector types listed in *IT. QCPort System Install and Planning Guide* (Publication No. MN05001002E).

Troubleshooting and Maintenance

Renewal Parts

The renewal parts for the QSNAP are shown in the following table.

Table 19: QSNAP Renewal Parts

Description	Part Number
J3 Jumper	Consult Factory
Starter Interface	Consult Factory
Auxiliary Contact	Consult Factory
Ground Fault Detector	Consult Factory
Auxiliary Plug	Consult Factory

Troubleshooting

Table 20: Troubleshooting

Observation	Possible Cause/Corrective Action
<i>IT</i> starter attempts to energize when RUN is commanded but will not stay in	Check 24V DC coil power supply.
<i>IT</i> starter will not energize	Control terminal block is not seated or connected properly on overload or customer wiring.
	Check 24V DC control power supply.
	Verify that the permissive bit is = 1.
	Check J3 wiring.
	Make sure there is not a trip.
Reversing starter will not energize	Unit already running in forward. The units are electrically and mechanically interlocked.
	Check J3 wiring.
Reversing starter will not energize but forward does	Check J3 wiring.
	Reversing interlock is jammed.
<i>IT</i> starter automatically energizes on power-up	Check J3 wiring.

February 2002

Appendix A: QSNAP Parameters

Refer to the following table when configuring the QSNAP.

Table 21: Configuration Parameters

Number	Parameter	Length	Units
1	Config Data	14	
2	Configuration CRC check	2	
3	Node ID	2	
4	QCPort mode	1	
5	Baud Rate	1	
6	Slave Address	1	
7	Production Dest	2	
8	Device ID Tag	16	
9	Prod Int	2	
10	Cons Int	2	
11	Parameter List	0	
12	Production List	0	
13	Consumption List	0	
32	Overload Trip FLA Value	4	Amps
33	Overload Trip Class Value	1	Class
34	Percent Initial Torque	1	%
37	Motor Start Ramp Time	2	mS
38	Motor Stop Ramp Time	2	mS
43	Current Threshold Warning Threshold	1	En/Dis
44	Current Threshold Warning Threshold	1	%
46	Current Threshold Warning Debounce	2	mS
51	Motor Underload Warning Level	1	En/Dis
52	Motor Underload Warning Level	1	%
54	Motor Underload Warning Debounce	2	mS
55	Motor Ground Fault Enable	1	En/Dis
56	Motor Ground Fault Debounce Time	2	mS
57	Motor Ground Fault Inhibit From Start Delay Enable	1	En/Dis
58	Motor Ground Fault Inhibit From Start Delay	1	S

Table 22: Data Parameters

Number	Parameter	Units	Length
11	Motor Control		1
12	Motor Control Status		1
13	Motor Control Faults		2
14	Button State		1
15	LED State		1
16	ASCII Text		1
18	RMS AC Current	Amps	4
22	Control DC Voltage	Amps	2
23	Thermal Pile Percentage	Volts	2
24	Temperature Deg C	%	2
26	Fault Quene	Hz	2

February 2002

Intelligent Technologies (IT) Publications and Support

Table 23: IT Publications

Publication	Description
MN05002001E	<i>IT. D77A- IO Module Products Installation and Users Manual</i>
MN05001002E	<i>IT. QCPort System Install and Planning Guide</i>
MN05001001E	<i>IT. QCPort Starter Network Adapter Product (QSNAP) Installation and Users Manual</i>
Pub 4960	<i>IT. Overload Relay Setup and Troubleshooting Guide</i>
Pub 49601	<i>IT. Overload Relay Quick Setup Guide</i>
MN05004001E	<i>IT. DeviceNet Starter Network Adapter Product (DSNAP) Installation and Users Manual</i>
MN05004002E	<i>IT. DeviceNet Adapter Installation and User Manual</i>
Pub 49907	Intelligent Technologies S751 Soft Starter User Manual

For copies of these and other publications contact the Literature Fulfillment Center at 1-800-957-7050.

Eaton's Cutler-Hammer Aftermarket Services

- Technical/telephone support
- Resident service engineers in major trading centers
- Factory repair services
- Warranty administration
- Equipment modification and upgrading services
- Training seminars

For additional information on this product, please call our Customer Support Center at:

1-800-356-1243

For service or start-up assistance 24 hours/day, 7 days/week, please call:

1-800-498-2678

A response network that gives new meaning to customer service

- Personalized
- Comprehensive
- Professional

Eaton Corporation
Cutler-Hammer business unit
1000 Cherrington Parkway
Moon Township, PA 15108-4312
USA
tel: 1-800-525-2000
www.cutler-hammer.eaton.com

EAT•N | **Cutler-Hammer**

© 2002 Eaton Corporation
All Rights Reserved
Publication No. MN05001001E
February 2002
Printed in USA

Free Manuals Download Website

<http://myh66.com>

<http://usermanuals.us>

<http://www.somanuals.com>

<http://www.4manuals.cc>

<http://www.manual-lib.com>

<http://www.404manual.com>

<http://www.luxmanual.com>

<http://aubethermostatmanual.com>

Golf course search by state

<http://golfingnear.com>

Email search by domain

<http://emailbydomain.com>

Auto manuals search

<http://auto.somanuals.com>

TV manuals search

<http://tv.somanuals.com>