

ECHO®

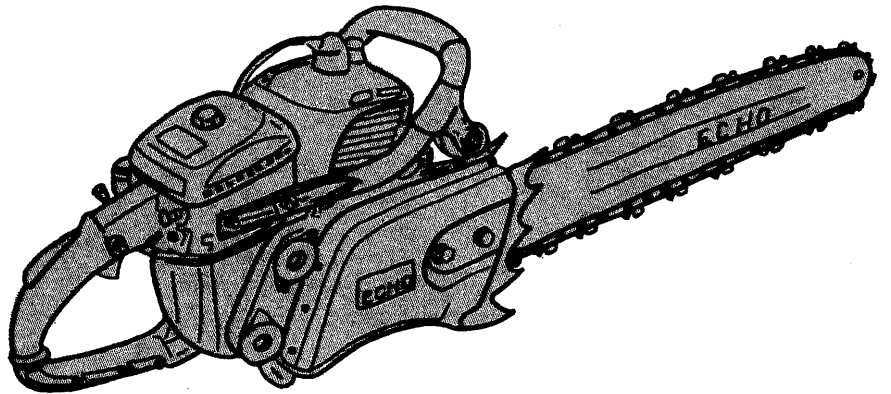

PARTS CATALOGUE

ECHO CHAIN SAW CS-1200 CS-1200VL-S



898 617-3293 3

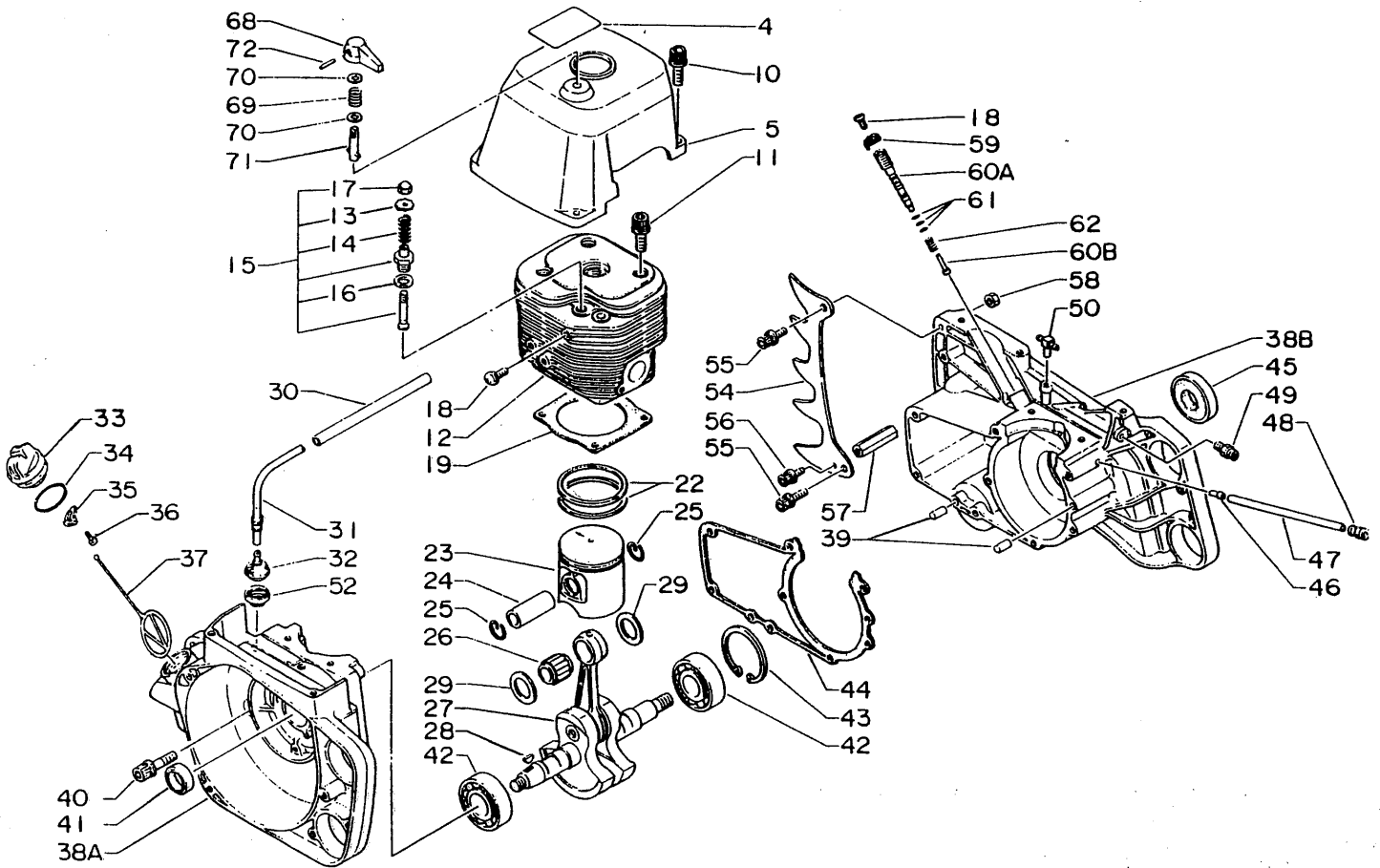

Key No.	Part Number	Q'ty	Description
1- 4	890 149-1643 0	1	Label, decomp.
5	101 514-1643 2	1	Cover, cylinder
<hr/>			
10	900 167-0602 5	3	Bolt, h.s.h.w/W,SW
11	900 169-0602 5	4	Bolt, h.s.h.w/W,SW
12	101 011-1643 3	1	Cylinder
15	101 100-1643 0	1	Decomp. ass'y
13	-101 114-0283 1	1	Washer
<hr/>			
14	-101 113-0283 0	1	Spring
16	-101 112-0283 0	1	Gasket
17	-400 912-0091 0	1	Nut
18	900 220-0501 0	2	Screw
19	101 010-1643 1	1	Gasket, cylinder base
<hr/>			
22	100 011-1643 1	2	Ring, piston
23	100 010-1643 1	1	Piston
24	100 013-1643 0	1	Pin, piston
25	100 015-1643 0	2	Circlip, piston pin
26	100 012-1643 0	1	Bearing, needle
<hr/>			
27	100 100-1643 0	1	Crankshaft ass'y
28	100 131-0162 0	1	Key, woodruff
29	100 014-1643 0	2	Spacer
30	437 412-1643 0	1	Tube
31	437 205-1643 0	1	Pipe
<hr/>			
32	436 205-1473 0	1	Strainer, oil
33	436 001-1643 1	1	Cap ass'y, oil
34	-900 720-0002 5	1	O-ring
35	-131 050-1983 0	1	Holder
36	-900 246-0300 8	1	Screw

15 includes 13, 14, 16 and 17.
33 includes 34 thru 37.

Key No.	Part Number	Q'ty	Description
1-37	-131 051-1983 0	1	Connector
38	100 200-1643 0	1	Crankcase set
39	-100 215-0283 0	2	Pin, dowel
46	-130 113-1233 0	1	Connector
50	-437 201-1473 0	1	Connector
<hr/>			
40	900 162-0603 0	8	Bolt, h.s.h.w/W,SW
41	100 213-1643 0	1	Oilseal
42	900 810-0620 4	2	Bearing, ball
43	900 702-0004 7	1	Circlip
44	100 242-1643 0	1	Gasket, crankcase
<hr/>			
45	100 212-1643 1	1	Oilseal
47	130 110-1643 0	1	Pipe
48	132 115-1233 0	1	Grommet
49	437 052-0033 0	1	Connector
52	436 212-1643 1	1	Cover oil strainer
54	880 210-1643 0	1	Bumper, spiked
<hr/>			
55	900 105-0602 0	2	Bolt, h.s.h.
56	900 167-0501 4	1	Bolt, h.s.h.w/W,SW
57	433 026-1643 0	1	Catcher, chain
58	145 713-0063 0	2	Nut
59	437 059-1113 3	1	Stopper, pump
<hr/>			
60	437 000-1643 0	1	Auto-oiler ass'y
61	-437 020-0283 0	3	O-ring
62	-437 019-0283 0	1	Spring
<hr/>			
68	179 815-1643 2	1	Button, decomp.
69	179 812-1643 1	1	Spring
70	900 600-0000 5	2	Washer
71	179 806-1643 1	1	Shaft
72	900 340-2001 4	1	Needle

38 includes 39, 46 and 50.
60 includes 61 and 62.

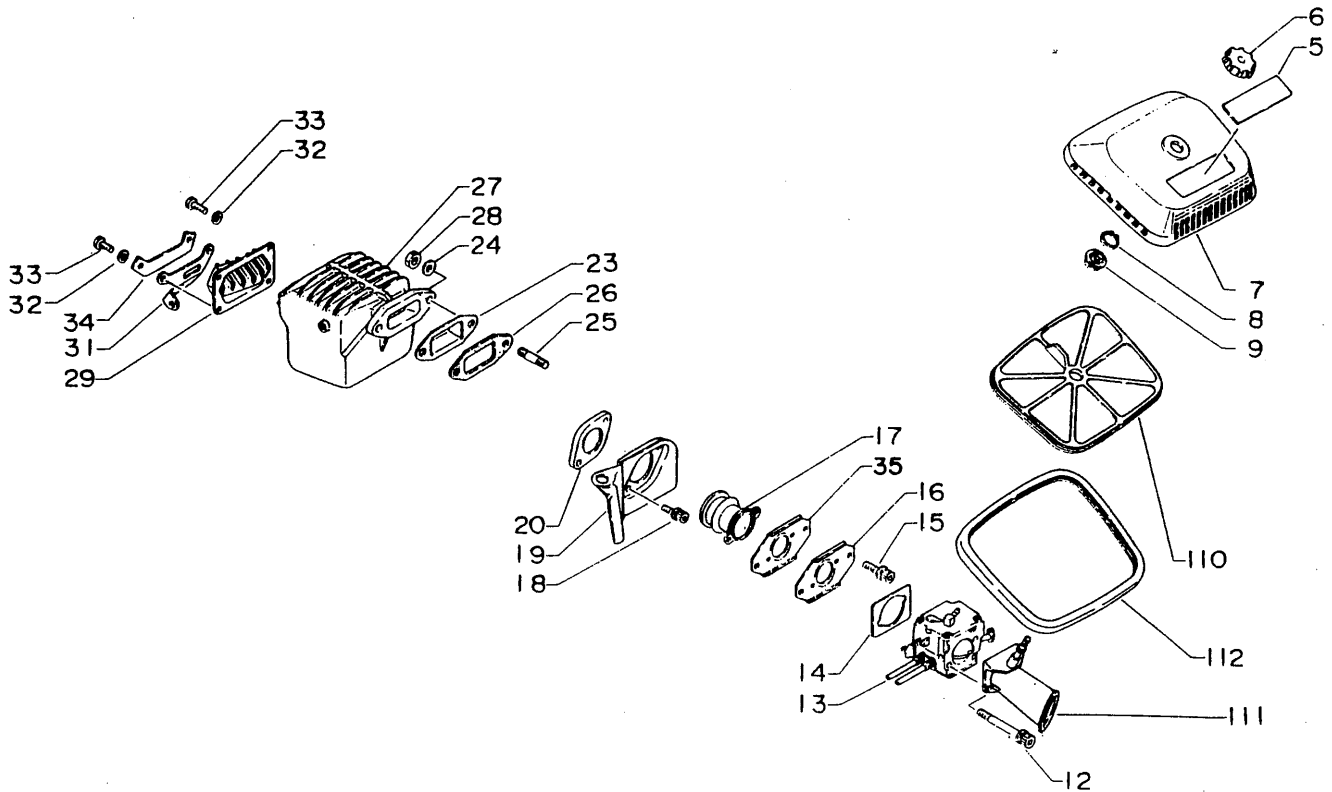

Key No.	Part Number	Q'ty	Description
2- 5	890 151-3293 0	1	Label, model CS-1200
5	890 034-3293 0	1	Label, model CS-1200VL-S
6	130 406-0033 0	1	Nut, thumb
7	130 313-1643 0	1	Cover, air cleaner
8	900 701-0001 1	1	Circlip
9	130 312-1643 0	1	Gasket, air cleaner
12	900 162-0505 0	2	Bolt, h.s.h.w/W,SW
13	122 000-3293 0	1	Carburetor
14	130 037-1643 0	1	Spacer
15	900 167-0501 4	2	Bolt, h.s.h.w/W,SW
16	130 013-1643 1	1	Bed, carburetor
17	130 510-1643 1	1	Bellows, intake
18	900 162-0502 0	2	Bolt, h.s.h.w/W,SW
19	130 011-1643 0	1	Plate, wind proof
20	130 512-1473 1	1	Holder, bellows
23	145 633-1643 0	1	Adapter
24	900 600-0000 6	2	Washer
25	101 014-1643 0	2	Stud
26	145 510-1643 1	1	Gasket, muffler
27	145 605-3293 0	1	Muffler
28	145 713-0063 0	2	Nut
29	145 818-1473 0	1	Lid, muffler
31	145 720-1643 1	1	Bracket
32	178 516-0083 0	4	Washer
33	900 150-0501 5	4	Bolt
34	145 642-1643 1	1	Lockwasher
35	130 012-3293 0	1	Seal, dust

Key No.	Part Number	Q'ty	Description
110	130 317-1643 0	1	Filter, air
111	130 714-1643 0	1	Elbow, intake
112	130 331-1643 0	1	Seal, airfilter

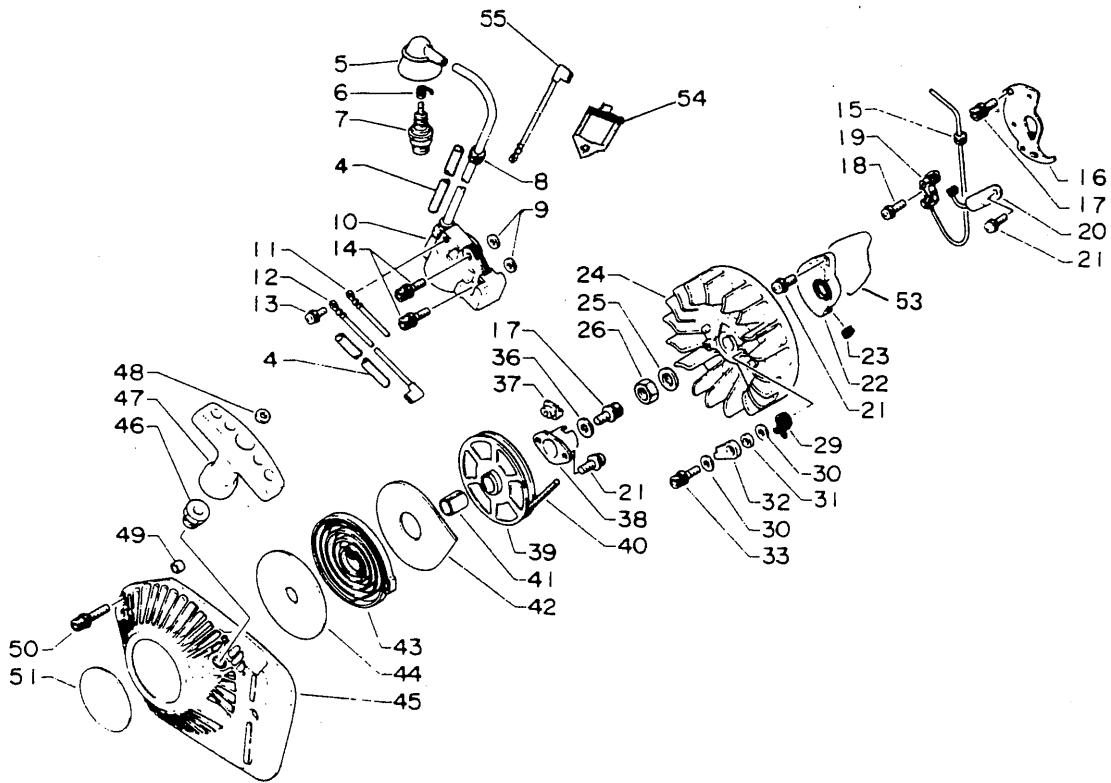

Key No.	Part Number	Q'ty	Description	Key No.	Part Number	Q'ty	Description
3- 4	437 412-1643 0	2	Tube	3-21	-900 242-0401 2	2	Screw w/W,SW
5	159 012-1643 0	1	Cap, spark plug	36	-300 217-0061 0	1	Washer
6	159 011-0343 2	1	Coil, spark plug cap	37	-177 246-1063 1	1	Clip
7	159 017- 1643 1	1	Plug, spark	38	-177 243-0283 3	1	Catcher, pawl
8	150 112-0031 0	1	Grommet	39	-177 215-1063 2	1	Reel, starter
9	150 117-1643 0	2	Spacer	40	-177 226-1473 0	1	Rope, starter
10	150 126-1643 1	1	Coil, ignition	41	-177 216-1063 0	1	Bushing
11	150 133-1643 0	1	Lead	42	-177 242-1473 0	1	Plate
12	150 131-1643 0	1	Lead	43	-177 220-1063 1	1	Spring, rewind
13	900 242-0401 0	1	Screw w/W,SW	44	-177 221-1063 0	1	Plate
14	900 162-0502 5	2	Bolt, h.s.h.w/W,SW	45	-101 507-1643 0	1	Cover, fan
15	151 114-0463 0	1	Grommet	46	-177 227-1063 0	1	Guide, rope
16	150 132-1643 0	1	Plate, stator	47	-177 228-1643 0	1	Grip, starter
17	900 167-0501 4	2	Bolt, h.s.h.w/W,SW	48	-177 229-1643 0	1	Spacer
18	900 242-0400 8	1	Screw w/W,SW	49	-101 522-1643 0	2	Pin, knock
19	150 101-1643 0	1	Breaker	50	900 167-0602 5	3	Bolt, h.s.h.w/W,SW
20	150 127-1643 0	1	Condenser	51	890 118-1793 0	1	Decal
21	900 242-0401 2	3	Screw w/W,SW	52	150 611-1473 0	1	Tube
22	150 128-1643 0	1	Cover, breaker	53	154 120-1643 0	1	Seal
23	156 114-0231 0	1	Bushing	** 54	152 601-3293 1	1	Module, T.C.I.
24	150 200-1643 1	1	Flywheel	** 55	162 010-3293 0	1	Lead
25	100 146-0031 0	1	Washer				
26	100 144-1233 1	1	Nut				
29	177 234-1473 0	2	Spring, pawl				
30	900 600-0000 6	4	Washer				
31	177 247-0283 0	2	Spacer				
32	177 218-0283 0	2	Pawl, starter				
33	900 100-0601 6	2	Bolt				
*	177 200-1643 1	1	Starter ass'y				
17	-900 167-0501 4	1	Bolt, h.s.h.w/W,SW				

* consists of 17, 21, 36 thru 49.

** : CS-1200VL-S

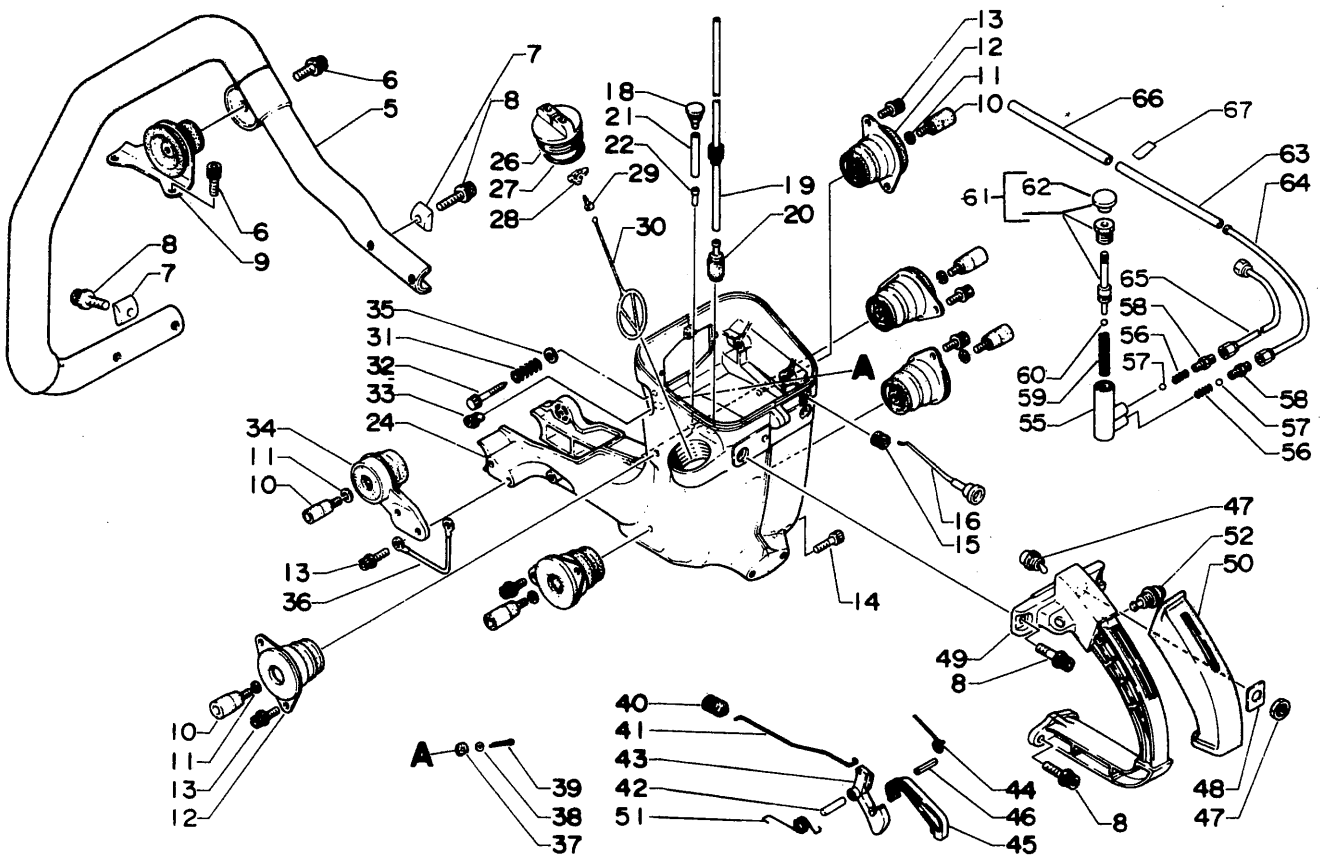

Key No.	Part Number	Q'ty	Description
4- 5	351 606-0526 0	1	Handle, front
6	900 167-0602 0	3	Bolt, h.s.h.w/W,SW
7	351 611-1643 0	4	Washer
8	900 169-0602 5	8	Bolt, h.s.h.w/W,SW
9	351 605-1643 0	1	Cushion
10	100 915-1643 0	6	Fastener cushion
11	900 605-0000 5	6	Washer, spring
12	100 910-1643 0	5	Cushion
13	900 167-0501 4	12	Bolt, h.s.h.w/W,SW
14	900 105-0501 4	4	Bolt, h.s.h.
15	178 810-0283 0	1	Grommet
16	178 510-1643 0	1	Rod, choke control
18	131 300-1643 0	1	Vent ass'y
19	132 007-1643 0	1	Pipe, fuel
20	131 205-1983 0	1	Strainer, fuel
21	131 312-1643 0	1	Pipe, vent
24	131 002-1643 1	1	Tank kit, fuel
22	-130 113-1233 0	1	Connector
26	131 004-1643 1	1	Cap ass'y, fuel
27	-900 720-0003 2	1	O-ring
28	-131 050-1983 0	1	Holder
29	-900 246-0300 8	1	Screw
30	-131 050-1983 0	1	Connector
31	129 020-1473 0	1	Spring
32	129 013- 1473 0	1	Screw, idle speed
33	129 010- 1473 0	1	Grommet
34	100 917- 1643 0	1	Cushion
35	900 600- 0000 4	1	Washer
36	162 010- 1473 2	1	Lead
37	131 410- 0033 0	1	Felt

24 includes 22.

26 includes 27 thru 30.

Key No.	Part Number	Q'ty	Description
4-38	900 600-0000 2	1	Washer
39	900 300-2001 5	1	Pin, split
40	178 211-0033 0	1	Grommet
41	178 011-1643 0	1	Rod, throttle
42	900 342-5002 5	1	Pin, spring
43	178 010-1473 0	1	Trigger, throttle control
44	178 091-1643 0	1	Spring
45	178 090-1643 0	1	Lockout, throttle control
46	900 342-4001 8	1	Pin, spring
47	163 400-1983 1	1	Switch, ignition
48	890 157- 1643 0	1	Label, stop
49	351 110- 1643 1	1	Handle, rear
50	351 111- 1643 0	1	Grip, rear handle
51	178 043- 1643 0	1	Spring
52	178 302- 1233 0	1	Latch, throttle
*	437 100- 1643 0	1	Pump ass'y, oil
55	-437 102-1643 0	1	Body ass'y, oil pump
56	-437 013-0033 0	2	Spring
57	-437 012-0033 0	2	Ball, valve
58	-437 052-0033 0	2	Connector
59	-437 111-0023 1	1	Spring
60	-900 720-0000 6	1	O-ring
61	-437 101-1473 0	1	Piston, oil pump
62	-437 119-1473 1	1	Button, push
63	437 211-1643 1	1	Pipe
64	437 207-3293 0	1	Pipe
65	437 206-1643 0	1	Pipe
66	437 412-1643 0	1	Tube
67	437 221-1643 0	2	Clip

* consists of 55 thru 62.

55 includes 56 thru 58.

61 includes 62.

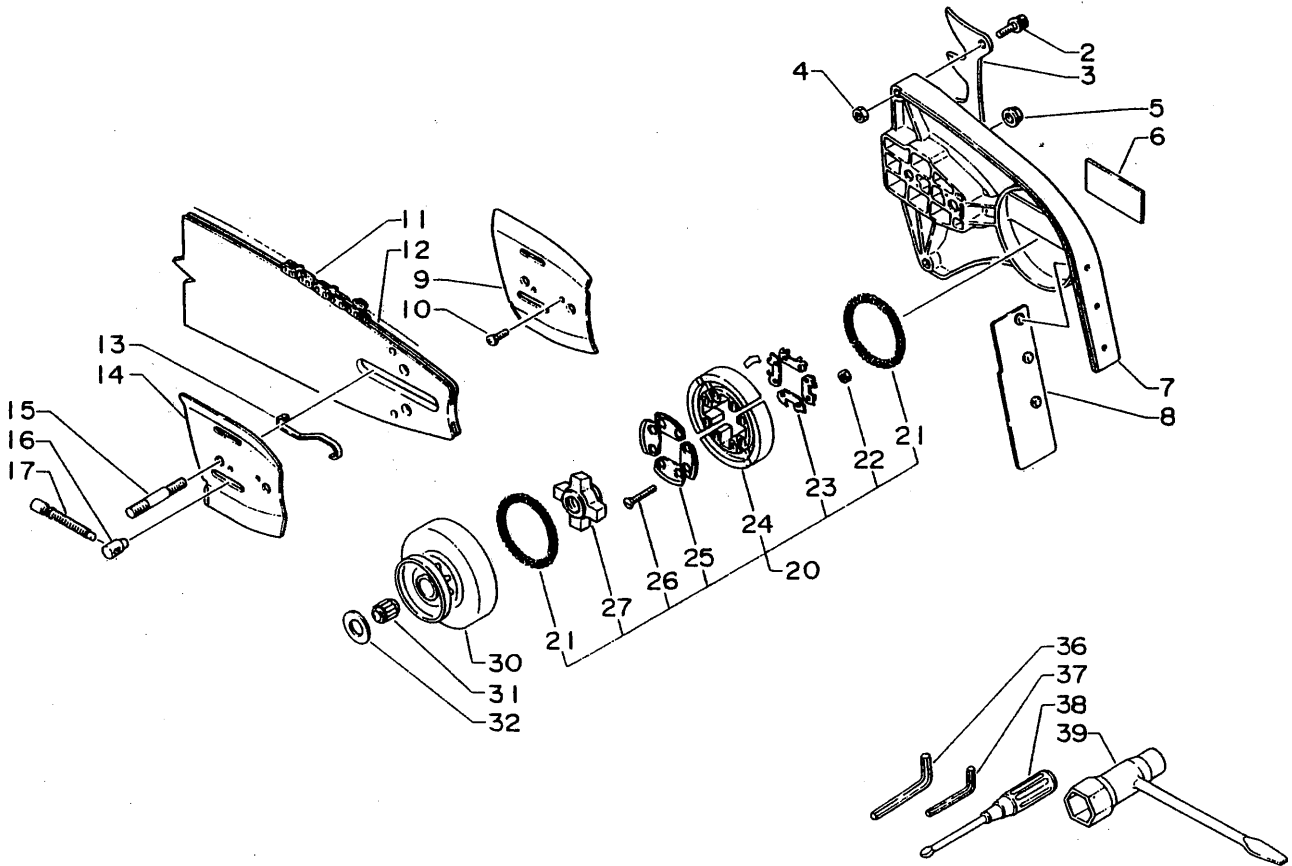

Key No.	Part Number	Q'ty	Description
5- 2	900 105-0602 0	2	Bolt, h.s.h.
3	880 210-1643 0	1	Bumper, spiked
4	145 713-0063 0	2	Nut
5	433 019-1063 1	2	Nut
6	890 118-3503 0	1	Decal
7	433 010- 1643 0	1	Guard, sprocket
*7	433 021-1643 0	1	Guard, sprocket
8	433 025- 1643 0	1	Pad
9	433 012- 1643 0	1	Plate, outer
10	900 241- 0300 6	1	Screw w/SW
11	431 135- 1643 1	1	Chain. saw 27-104E
11	431 136- 1643 1	1	Chain, saw 27-100E
12	430 330- 1643 0	1	Bar, guide 36G63
12	430 332- 1643 1	1	Bar, guide 33G63
13	433 035-1643 0	1	Holder, plate
14	433 013-1643 0	1	Plate, inner
15	433 011-1643 0	2	Stud
16	433 014-1643 0	1	Tensioner
17	433 016-1643 0	1	Screw, adjustment
20	175 000-1643 4	1	Clutch ass'y
21	-175 004-1643 0	2	Spring, clutch
22	-900 560-0000 5	8	Lock nut
23	-175 029-1643 1	3	Plate, outer
24	-175 017-1643 2	4	Shoe, clutch
25	-175 019-1643 2	4	Plate, inner
26	-175 021-1643 0	8	Screw
27	-175 016-1643 0	1	Hub, clutch
30	-175 006-1643 4	1	Drum, clutch
31	175 012-1643 0	1	Bearing, needle

Key No.	Part Number	Q'ty	Description
32	100 618-1643 1	1	Plate
36	895 611-0033 0	1	L-wrench 5 mm
37	895 610-0013 0	1	L-wrench 4 mm
38	895 811-0013 0	1	Screwdriver
39	895 410-1063 0	1	Wrench w/screwdriver

20 consists of 21 thru 27.

* 7 Option.

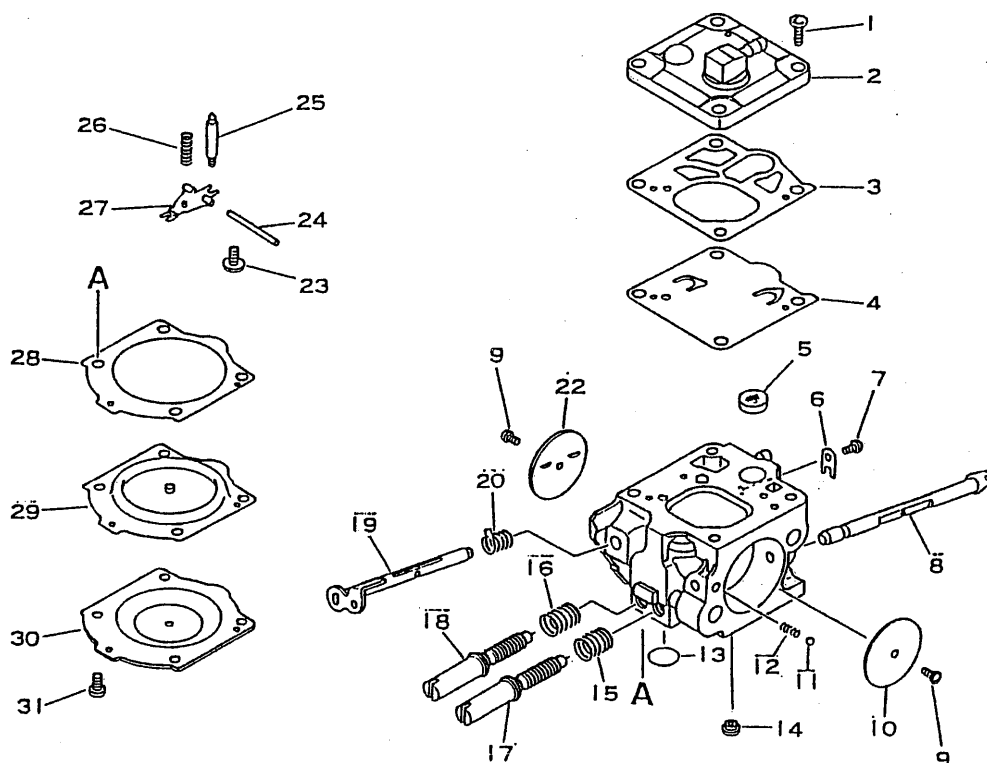

KEY	LV	PART NUMBER	Q'TY	DESCRIPTION	APPLICATION	REMARKS	INF. NR
		122000-32930	1	CARBURETOR HIS-266A			
1	+	122110-00231	4	SCREW			
2	+	122124-14730	1	COVER, FUEL PUMP			
3	+	122125-00230	1	GASKET, PUMP			
4	+	122112-00230	1	DIAPHRAGM, PUMP			
5	+	122126-00230	1	SCREEN, FUEL			
6	+	122127-00230	1	CLIP, THROTTLE SHAFT			
7	+	122114-32930	1	SCREW			
8	+	122131-32930	1	SHAFT, CHOKE			
9	+	122144-00231	2	SCREW & LOCKWASHER			
10	+	122132-10630	1	VALVE, CHOKE			
11	+	122136-00230	1	BALL, CHOKE SET			
12	+	122135-00230	1	SPRING, CHOKE FRICTI			
13	+	122145-00230	1	PLUG, WELCH (L)			
14	+	122147-32930	1	VALVE, CHECK			
15	+	122119-10630	1	SPRING, NEEDLE			
16	+	122121-10630	1	SPRING, IDLE NEEDLE			
17	+	122120-32930	1	NEEDLE, HIGH SPEED			
18	+	122118-32930	1	NEEDLE, IDLE			
19	+	122117-32930	1	SHAFT, THROTTLE			
20	+	122113-32930	1	SPRING, RETURN			
22	+	122116-32930	1	VALVE, THROTTLE			
23	+	122139-00231	1	SCREW			
24	+	122138-00230	1	SHAFT, LEVER			
25	+	122137-00230	1	VALVE, INLET NEEDLE			
26	+	122122-00230	1	SPRING, TENSION			
27	+	122123-00230	1	LEVER, INLET CONTROL			
28	+	122140-00230	1	GASKET, DIAPHRAGM			
29	+	122141-00230	1	DIAPHRAGM			
30	+	122142-14730	1	COVER, DIAPHRAGM			
31	+	122144-00231	4	SCREW & LOCKWASHER			

(OPTION)

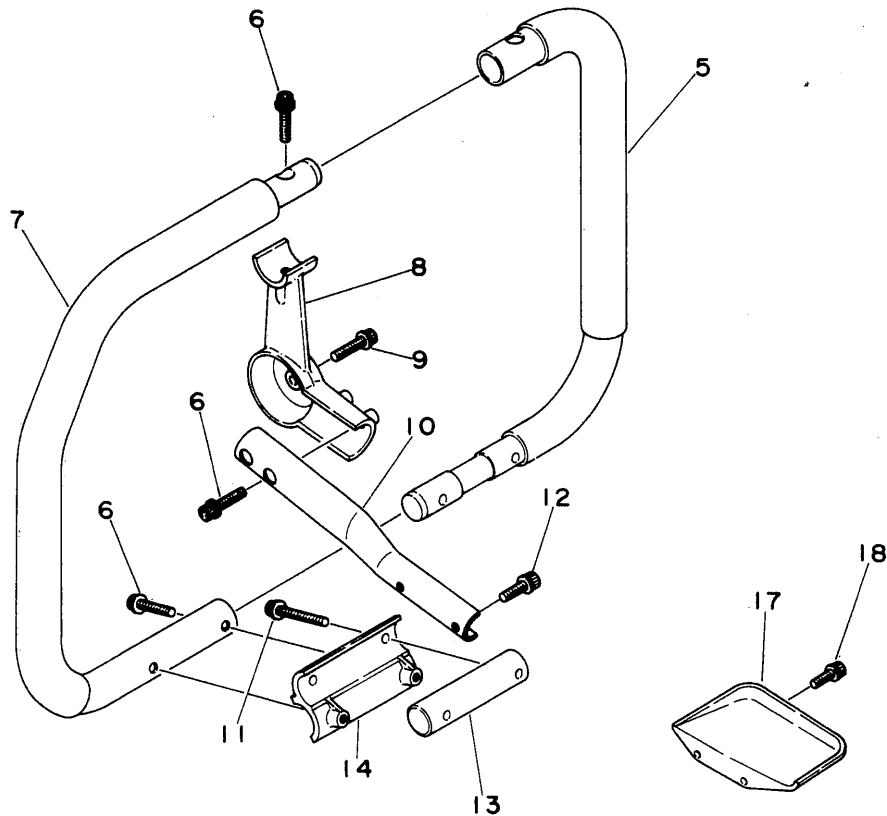

Key No.	Part Number	Q'ty	Description
5	351 407-1643 0	1	Handle, front, R
6	900 162-0603 0	5	H.S.H. bolt 6x30
7	351 405-1643 0	1	Handle, front, L
8	351 415-1643 0	1	Bracket
9	900 162-0602 0	1	H.S.H. bolt 6x20

10	351 408-1643 0	1	Retainer
11	900 162-0604 5	2	H.S.H. bolt 6x45
12	900 162-0602 5	2	H.S.H. bolt 6x25
13	351 428-1643 0	1	Spacer
14	351 425-1643 0	1	Bracket

17	351 133-1643 0	1	Guard, rear
18	900 162-0502 0	2	H.S.H. bolt 5x20

**KIORITZ CORPORATION**

7-2, SUEHIROCHO 1-CHOME, OHME, TOKYO 198, JAPAN
 PHONE: 0428-32-6118, FAX: 0428-32-6145, TELEX: 2852070 KIORIT J

Free Manuals Download Website

<http://myh66.com>

<http://usermanuals.us>

<http://www.somanuals.com>

<http://www.4manuals.cc>

<http://www.manual-lib.com>

<http://www.404manual.com>

<http://www.luxmanual.com>

<http://aubethermostatmanual.com>

Golf course search by state

<http://golfingnear.com>

Email search by domain

<http://emailbydomain.com>

Auto manuals search

<http://auto.somanuals.com>

TV manuals search

<http://tv.somanuals.com>