



Quietlift

2 4

AC Powered Belt Drive



TABLE OF CONTENTS

Warranty Information	2
Your Documentation Package	3
Safety Information.....	4
Safety Features.....	4
Important Installation Instructions.....	4
Pre-Installation Checklist	5
Adjustments.....	9-10
Programming the Remote Control	11
Installation of Light Bulb	19
Troubleshooting Guide	20-21
Parts List and Explosion.....	22
Accessories	23

COMPLETE WITH INTELICODE REMOTE CONTROL AND SERIES II ELECTRONICS

For up to 7' 6" tall Doors.

Included Wall Control **MUST** be installed prior to Operation of this Garage Door Operator.

Safe-T-Beam® Safety Reverse System **Must** be Installed and the Force Controls **MUST** be Properly Set to close door.

This Equipment meets or exceeds all Federal, State and UL 325 Safety Requirements.

Having Difficulty? Need Help?

Please call us: 1-800-35-GENIE (354-3643)

www.geniecompany.com

Please have Model information ready when calling.

THE GENIE COMPANY LIMITED WARRANTY

What is covered?

Any defect in material and product workmanship from personal, normal household use in accordance with the Owner's Manual.

For how long?

MODEL 2040L . . . 15 years on motor, 3 years all other parts.

MODEL 2040C . . . Lifetime* on motor, 3 years all other parts.

*For as long as you own your home.

Who gets the warranty?

This warranty is limited to the consumer who originally purchased the product.

Geographic scope:

This warranty applies only to units installed and operated within the country where they were purchased.

Limitations:

IMPLIED WARRANTIES, INCLUDING THOSE OF FITNESS FOR A PARTICULAR PURPOSE AND MERCHANTABILITY (AN UNWRITTEN WARRANTY THAT THE PRODUCT IS FIT FOR ORDINARY USE), ARE LIMITED TO ONE YEAR FROM THE DATE OF PURCHASE. GENIE WILL NOT PAY FOR: LOSS OF TIME; INCONVENIENCE; LOSS OF USE OF YOUR GENIE PRODUCT OR PROPERTY DAMAGE CAUSED BY YOUR GENIE PRODUCT OR ITS FAILURE TO WORK; ANY SPECIAL, INCIDENTAL OR CONSEQUENTIAL DAMAGES; OR ANY DAMAGES RESULTING FROM MISUSE OR MODIFICATION OF YOUR GENIE PRODUCT.

Some states and provinces do not allow limitations on how long an implied warranty lasts or the exclusion of incidental or consequential damages, so the above limitations or exclusions may not apply to you.

This warranty is the only one we will give on your Genie product, and it sets forth all our responsibilities regarding your Genie product. There are no other express warranties.

State and province rights: This warranty gives you specific legal rights, and you may also have other rights which vary from state to state and province to province.

How to get warranty service:

To obtain warranty service for your Genie product, you must provide proof of the date and place of purchase of the product.

1. Do-It-Yourself-Service.

Call the Genie Customer Service toll free at 1.800.354.3643 to speak in person to a trained Genie representative for assistance in diagnosing the problem and arranging to supply you with the required parts for do-it-yourself repairs. Trained service representatives are available Monday-Friday, 8:00 a.m. - 11:00 p.m., Eastern Time, and on Saturday, 10:00 a.m. to 8:00 p.m., Eastern Time (subject to holidays) You may also get the information you need at www.geniecompany.com.

2. Service From Authorized Dealers.

You also may obtain warranty service from Genie authorized dealers by calling the Genie Customer Service at 1.800.354.3643 or by visiting www.geniecompany.com before scheduling warranty service. If warranty service is provided by an authorized dealer, Genie will provide all required parts under warranty at no charge to you, but the dealers are independent business people and may render a bench or service call charge for their services. Genie will not reimburse you or otherwise be responsible for those charges.

We suggest that you retain your original packing material in the event we choose to repair or replace your Genie Product and request that you ship it to us. Be sure to include your name, address, telephone number, proof of date and place of purchase and a description of the operating problem. After repairing or replacing, your Genie product, we will ship it to your home at no cost to you for parts and labor, but you will have to pay a minimum of \$5.00 for shipping and handling charges.

Your choice of either one of the above-described service options is your exclusive remedy under this warranty.

What this warranty does not cover:

This warranty does not cover batteries (which are considered replaceable parts), installation, commercial use, defects resulting from accidents, damage while in transit to our service location or damage resulting from alterations, misuse or abuse, lack of proper maintenance, unauthorized repair or modification of the product, affixing of any attachment not provided with the product, programming of the Remote Control Devices, Safe-T-Beam® adjustment/cleaning, staples through wiring, pinched or broken wires, Carriage disengaged, Force Control adjustments, door out of balance, broken springs or cables, power outages, use of extension cords, missing or damaged parts on discounted, clearanced, final sale or taped cartons, phantom operations (labor is not covered if Opener is functioning properly while technician is in garage), fire, flood, or acts of God, or other failure to follow the Owner's Manual.

FOR ANSWERS: CALL 1.800.354.3643

Please note the following information, so it is available if you need to call us.

Date Purchased _____ / _____ / _____
Serial Number _____
Operator Model _____
Remote Control Model _____
Dealer Name _____
Dealer Address _____
City _____
State _____
Zip _____

INCLUDED IN THIS PACKAGE

- Warranty Information
- Pre Installation Checklist to be reviewed prior to any assembly or installation
- Pictorial and step by step opener assembly instructions
- Pictorial and step by step opener installation instructions
- Necessary Adjustments
- Programming Remote Devices
- Maintenance and Troubleshooting
- Parts Explosions
- Accessory Order Form
- Door Opener Association Safety and Maintenance Brochure (DASMA)
- Entrapment Warning Label - To be Adhered in close proximity to wall control

NOTE

Please keep original or photocopy of your sales receipt with this manual for future reference should service ever be required.

IT IS CRITICAL THAT ALL SAFETY WARNINGS MARKED CLEARLY IN BOTH THE MANUAL AND POSTER ARE READ, UNDERSTOOD AND FOLLOWED.

Visit Our Website at: www.geniecompany.com
SAVE THESE INSTRUCTIONS

OVERVIEW OF POTENTIAL HAZARDS

Garage Doors are heavy objects that move with the help of springs under high tension and electric motors. Since moving objects, springs under tension, and electric motors can cause injuries, your safety and the safety of others depend on you reading the information in this manual. If you have questions or do not understand the information presented, call your nearest service representative.



In this section, and those that follow, the words **Danger**, **Warning** and **Caution** are used to emphasize important safety information. The word:

▲ DANGER: indicates an imminently hazardous situation which, if not avoided, will result in death or serious injury.

▲ WARNING: indicates a potentially hazardous situation which, if not avoided, could result in death or serious injury.

▲ CAUTION: indicates a potentially hazardous situation which, if not avoided, may result in injury and property damage.

The word **NOTE** is used to indicate important steps to be followed or important information.

POTENTIAL HAZARD	EFFECT	PREVENTION
 MOVING DOOR	WARNING: Can Cause Serious Injury or Death	<ul style="list-style-type: none"> • Keep people clear of opening while door is moving. • Do Not allow children to play with the door operator. • Do Not operate a door that jams or one that has a broken spring.
 ELECTRICAL SHOCK	WARNING: Can Cause Serious Injury or Death	<ul style="list-style-type: none"> • Turn off power before removing operator cover. • When replacing cover, make sure wires are not pinched or near moving parts. • Operator must be properly grounded.
 HIGH SPRING TENSION	WARNING: Can Cause Serious Injury or Death	<ul style="list-style-type: none"> • Do Not try to remove, repair or adjust springs or anything to which door spring parts are fastened, such as, wood blocks, steel brackets, cables or other like items. • Repairs and adjustments must be made by a trained service person using proper tools and instructions.

IMPORTANT INSTALLATION INSTRUCTIONS

▲ WARNING:

TO REDUCE THE RISK OF SEVERE INJURY OR DEATH:

- 1 READ AND FOLLOW ALL SAFETY, INSTALLATION AND OPERATION INSTRUCTIONS. If you have any questions or do not understand an instruction, call your service representative.
- 2 Do Not install operator on an improperly balanced door. An improperly balanced door could cause severe injury. Repairs and adjustments to cables, spring assembly, and other hardware must be made by a trained service person using proper tools and instructions.
- 3 Remove all ropes, and disable all locks connected to the door before installing operator.
- 4 Install door operator 7 feet or more above the floor. Mount the emergency release knob 6 feet above the floor.
- 5 Do Not connect the operator to the source of power until instructed to do so.
- 6 Locate the control button:
 - Within sight of door.
 - At a minimum height of 5 feet, so small children cannot reach it.
 - Away from all moving parts of the door.
- 7 Install the entrapment WARNING label next to the wall button or console. Install the emergency release tag on, or next to, the emergency release
- 8 The operator must reverse when the door contacts a 1-1/2 inch high object on the floor at the center of the doorway. This is about the size of a 2" x 4" board laid flat.

SAFETY FEATURES

Safe-T-Beam® (STB) Non-Contact Reversing System

Places an invisible beam across door opening, that reverses the door during down travel to the fully open position if anything passes through beam.

Safe-T-Reverse® Contact Reversing System

Automatically stops and reverses a closing door within 2 seconds of contact with an object.

Safe-T-Stop® Timed Reversed System

Automatically opens a closing door, if door does not close within 30 seconds.

Force Guard® Control

Used to set the force required for opening and closing door. For maximum safety, set the minimum force required to fully open and close door.

Automatic Lighting System

Light bulb up to 100 Watts max. , used for safer entries and exits. The light turns on when door is activated and automatically turns off 5 minutes later.

Manual Emergency Release

Allows the garage door to be opened or closed manually for emergencies or maintenance.

PRE-INSTALLATION CHECKLIST

This Opener includes parts and supplies needed to install in **most** garages and connect to **most** garage doors. There are many variations of garages and garage doors. A few additional parts and supplies may be needed to install Opener into **your** garage and connect to **your** garage door. While checking items listed below, note any additional items you will need.

Tools used in this section:

- 12'+ Tape Measure
- Pencil
- Ladder
- Level

Check following items before assembling Opener:

Check Step 1: CHECK DOOR CONDITION AND THICKNESS

Check condition of vertical stile in center of door, and its connection to door's top and bottom beams. (Figure 2)

- A** If door frame is nailed together and not a solid connection, door frame must be braced or reinforced before installing Opener.
- B** If door is "lightweight" (made with frame and skin - not solid), door (including door frame) **must be braced or reinforced before installing Opener.**
- C** A door opener reinforcement bracket may also be needed to connect garage door to Opener's Door Bracket. This Opener is designed for installation on a **properly braced** sectional door or **solidly braced** one-piece door.
- D** Contact your Genie Factory Authorized Dealer or dealer of your garage door for any necessary bracing and a door opener reinforcement bracket (if needed) before proceeding.
- E** If you have a wooden door, measure door's thickness. If your door is less than 2" thick, brace door or use shorter Door Bracket Lag Screws (1/4" x 1-1/4" - not included)

Check Step 2: CHECK GARAGE DOOR ALIGNMENT, OPERATION, AND BALANCE

- A** Raise door, check alignment and see if it moves freely (Figure 1). If door appears out of alignment, binds, or does not move smoothly, contact a Genie Factory Authorized Dealer or dealer of your garage door for repairs and adjustments to door mechanism.
- B** Raise door to 3' - 4' above ground and carefully let go. Door should stay stationary. Slight movement is acceptable. More than slight movement means door is out of balance. Contact a Genie Factory Authorized Dealer or dealer of your garage door for repairs and adjustments to door mechanism.
- C** Check door type. Make a note of whether it is a sectional or a one-piece door (Figure 2).

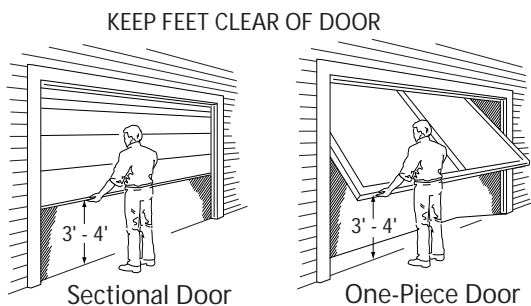

Figure 1 Checking door balance

⚠ WARNING:

If your door sticks, binds, or is out of balance, have it adjusted by a Genie Factory Authorized Dealer. Door springs, cables, pulleys, brackets and associated hardware are under extreme tension and can cause serious injury or death.

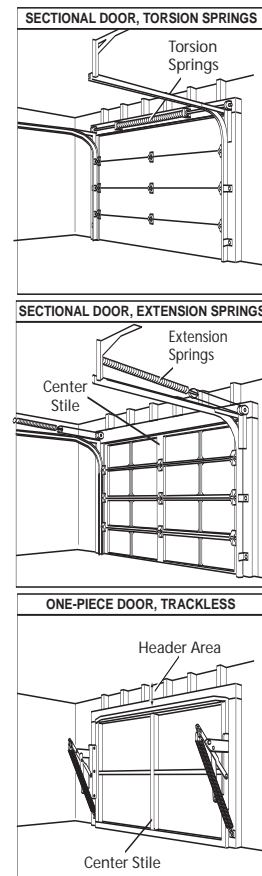

Figure 2 Note Door Type

Check Step 3: MEASURE GARAGE DOOR HEIGHT

- A** The Belt Drive Garage Door Opener is designed for doors up to and including 7' 6" tall.
- B** If door height is 8'-0", you need a Rail Extension Kit. (See Accessories Order Form, Page 23).
- C** If the door height is taller than 8'-0", the opener you purchased is the wrong version. Contact your Customer Service Representative at 1-800-354-3643.

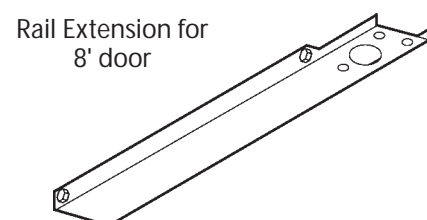

Figure 3 Rail Extension Kit

Check Step 4: CHECK DOOR HEADER AREA

NOTE

The header is a heavily reinforced section of the wall just above the top of the garage door opening.

- A** Find vertical center line of door and header:
- Close door.
 - Measure door width at top.
 - Mark a point at center of door and on header directly above door. Draw a center line to connect points.
- B** Find Header Bracket mounting height (**Figure 4**): (Do not attach Header Bracket).
- Raise door, watching top edge of door and stop door when its edge reaches its highest point.
 - Measure distance ("H") from top edge of door to floor.
 - For sectional doors, add 1" to "H". Mark a point on center line. Bottom of Header Bracket will be installed here.
 - For one-piece doors, add 7" to "H". Mark this point on center line. Bottom of Header Bracket will be installed here.

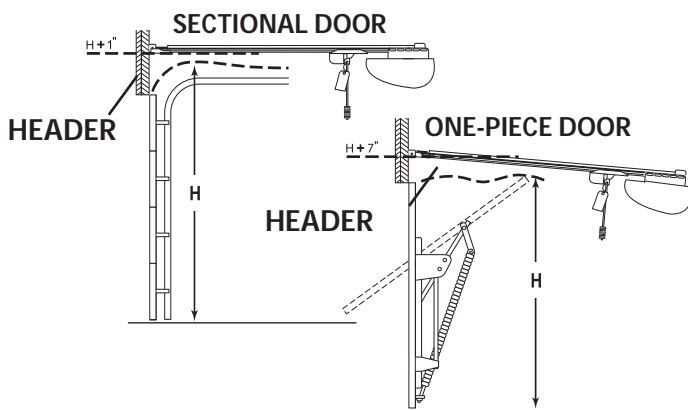

Figure 4 Find Highest Point of Travel

NOTE

- For both types of doors:
 - If the ceiling in your garage is so low that there is not at least a 3" space above the Header Bracket mounting point, contact a Genie Factory Authorized Dealer.
- If a door spring is in the way, place the Header Bracket above the spring. **Do Not** move the door spring.

- C** Check wall for a stud or a solid header at your mark: (If checking a finished wall, a stud finder may be helpful).
- If location is above Header, a 2" x 6" board must be screwed to studs beside your mark with at least two Lag Screws and Flat Washers (not provided).
 - Transfer your mark to new mounting board.

Check Step 5: CHECK POWER HEAD MOUNTING AREA

Check ceiling or space above where Opener Power Head will be mounted (**Figure 5**):

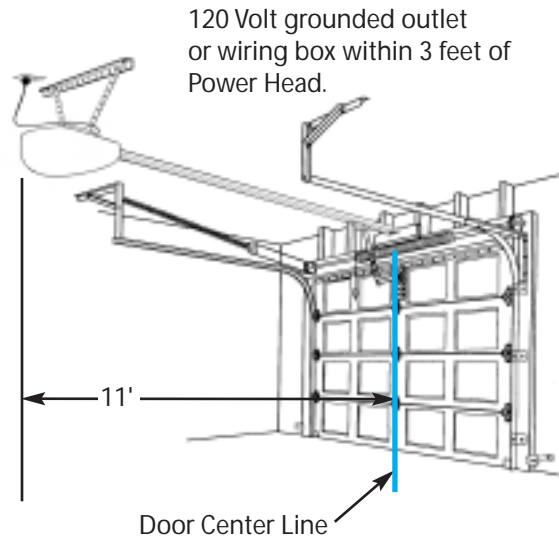
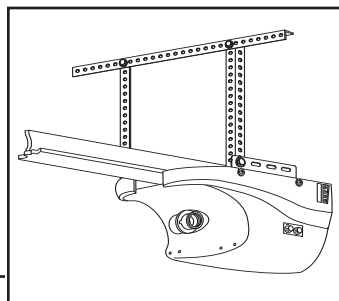

Figure 5 Check Power Head location

- A** Measure from garage door center line toward rear of garage:
- Approximately 11'.
- B** Find location of ceiling joist or truss above where Opener Power Head will be and estimate type and quantity of materials needed for your installation (**Figure 6**).

MOUNTING EXAMPLES

Perforated Angle Iron



Conduit

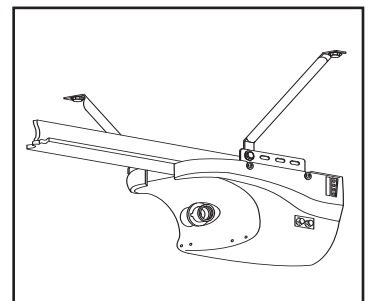

Perforated Straps

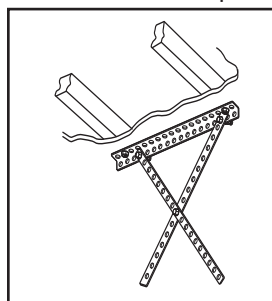

FINISHED CEILINGS

Locate ceiling joists or trusses using a stud finder or similar device.

Attach angle iron (not included) to joists or trusses through finish material using Lag Screws.

OPEN CEILINGS Straps and angle iron may attach directly to joists or trusses.

Figure 6 Mounting methods for open beam or finished ceilings

Check Step 6: CHECK CEILING FOR GROUNDED POWER SOURCE

- A** Check that there is a 15 Amp 120 Volt grounded electrical outlet or grounded permanent wiring box (per building code) within 3' of Opener Power Head:
- If not, an outlet or wiring box must be installed. Contact a licensed electrician for installation.
 - If building codes require permanent wiring, Power Head must be partially disassembled to install appropriate wiring in place of Power Cord. See Assembly and Information Poster.

NOTE

Permanent wiring must be installed by a Licensed Electrician. Not all Genie Factory Authorized Dealers are Licensed Electrician's. Contact someone who is a Licensed Electrician.

⚠ WARNING

Do Not use an extension cord! Extension cords can cause dangerous overheating conditions.

Do Not use portable generator! This product is designed to operate using standard house current. **Do Not** use alternate power supplies,

Check Step 7: CHECK SAFE-T-BEAM® MOUNTING BRACKET LOCATION

Check for wood garage frame, jamb, or masonry at mounting location (6" above floor) with attachment tabs facing away from garage door (**Figure 7**).

- A** If you cannot mount Safe-T-Beam® Mounting Bracket to wood frame:
- Concrete screws and concrete anchors (not included) must be used to mount Brackets on masonry with attachment tabs facing away from garage door.

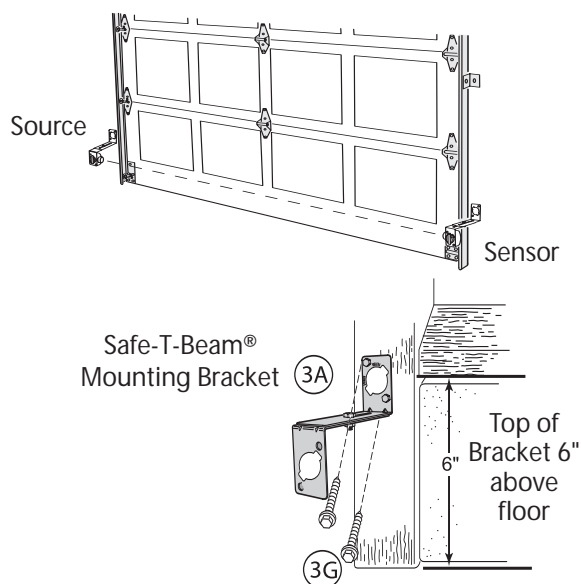

Figure 7 Mounting Safe-T-Beam® Components

Check Step 8: RECOMMENDED TOOLS

- A** Tools (**Figure 8**):
- B** Additional tools to make installation easier:
- Slotted and phillips screw-driver bits
 - Stud finder
 - Sheet-metal cutting snips

Check Step 9: REMOVE EXISTING GARAGE DOOR LOCKS

Check that the garage door locks, rope, and T-Handles are removed from the garage door before starting the installation.

- A** If your garage does not have a separate entry door, it is highly recommended to install a Genie Emergency Release Kit (**GER-2**). Emergency Release Kit lets you open the garage door from outside if there is a power failure. (Please see Accessories Order Form on page 23.)

Before going further, get any items and tools needed for your installation

- Garage door frame reinforcement brackets, screws, bracing or reinforcement kits (dealer)
- Lag Screws (1-1/4") for a wood door less than 2" thick (store)
- Electrical outlet and/or wiring (supplied by a licensed electrician)
- Sufficient angle iron or strapping for hanging Power Head (store)
- 100 Watt light bulb (Rough service bulbs recommended)(store)
- GER-2 Emergency Release Kit for entry during power failure (store)
- Wood for header, ceiling, and/or door bracing reinforcement (if needed)
- Masonry fasteners for Safe-T-Beam® Bracket installation, (if needed)
- Masonry drill bit (if needed)
- Extension Kit (for 8' Garage Doors)

Go to Assembly and Installation Poster for full Installation Instructions.

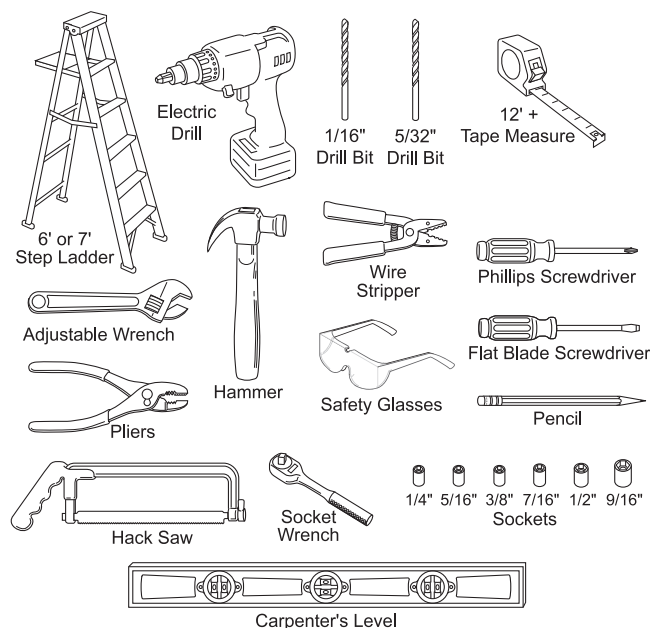

Figure 8 Recommended Tools

MAINTENANCE AND ADJUSTMENTS

Step 1: ALIGNING THE SAFETY-T-BEAMS®

⚠ WARNING

THE SAFE-T-BEAM® MUST BE ALIGNED OR THE OPENER WILL NOT FULLY FUNCTION.

Serious injury or death from a closing garage door may result because of failure to test the safety reverse system. Repeat this test monthly and adjust as needed.

NOTE

The Safe-T-Beam® is an invisible ray of light that travels across the bottom of the garage door opening (Figure 1). If an object blocks the beam while the garage door is closing, the opener will stop, then reverse and fully open the door.

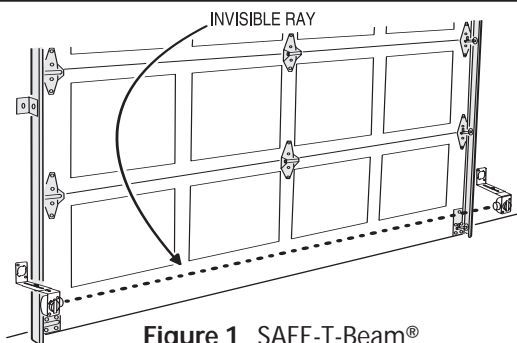

Figure 1 SAFE-T-Beam®

NOTE

The Safe-T-Beam® indicator lights display the status of the Safe-T-Beam® system (Figure 2).

Source Red LED	Sensor Green (2 LED's)
ON = Power On OFF = Power Off	BOTH OFF = NoPower ONE OFF / ONE ON = Misaligned.
If OFF, check wire connection at Powerhead. Check for broken or shorted wires. Check for defective source.	ONE ON / ONE BLINKING = Beam needs better alignment. BOTH ON = Normal Function, No Obstruction.

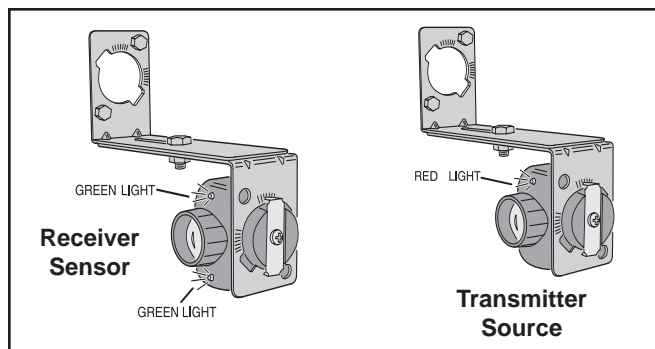

Figure 2 Indicator Lights

A Adjusting the beam (Figure 3).

- Adjust the source and sensor units until the Green indicator lights stay on.
 - Be sure to stay out of the path of the beam while making adjustments.
- If one Green indicator light stays off, check for
 - Dirt on the lens.
 - Sun shining into the lens.
 - A short in the wiring (check staples and connections at terminals).

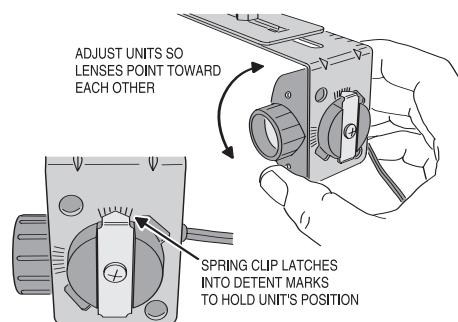

Figure 3 Adjusting Beam

⚠ WARNING

Be sure the carriage is disengaged from the belt before performing the following portion of the Safety-T-Beam® testing. The carriage is disengaged when the release lever is pointing down (Figure 4).

- B** Check the reverse function.
- Check that the Carriage is disengaged (Figure 4).
 - Press the wall button to move the bullet (Figure 5) to the open position (away from the door) (Figure 4).
 - Observe the belt as it travels and adjust tension if necessary.
 - Press the wall button to start the bullet in the close direction.
 - Block the Safe-T-Beam® while the bullet is moving toward the door (Figure 6).
 - The bullet must stop and reverse direction when the beam is blocked.
- C** Check the forced closure feature (Figure 7).
- Block the Safe-T-Beam®.
 - Press the wall button and verify that the bullet moves in the close direction as long as you hold the button but reverses whenever you let go of the button (Figure 7).

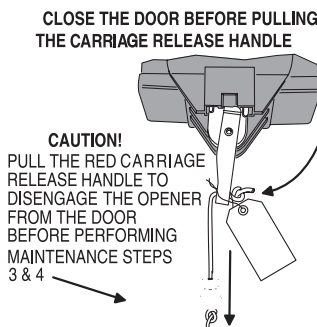

Figure 4 Disengage carriage

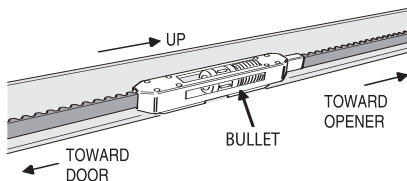

Figure 5 observe bullet travel

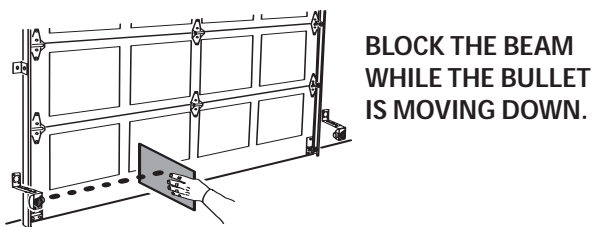

Figure 6 Block the beam

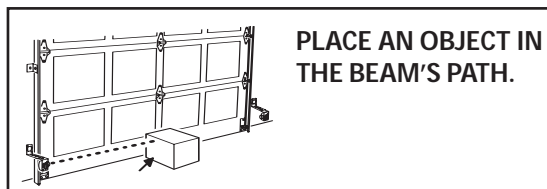

Figure 7 Block the beam

MAINTENANCE AND ADJUSTMENTS

Step 2: PROGRAMMING REMOTE CONTROLS

⚠ WARNING

A moving garage door may cause serious injury or death.

- Keep people clear of opening while door is moving.
- Do not allow children to play with Remote Controls.

If the Safety Reverse does not work properly:

- Close the door and disconnect the Opener using the Emergency Release Cord.
- Do not use the door Opener, Remote Controls, or Wireless Keypad.
- Refer to the door and door Opener Owner's Manuals before attempting any repairs.
- Stay clear of the opener's belt, the door and any other moving parts when operating the opener with a remote control.

- A** To Program one Button of a Remote Control
- Locate Learn Button and Learn Indicator Light on side of Power Head (Figure 1).

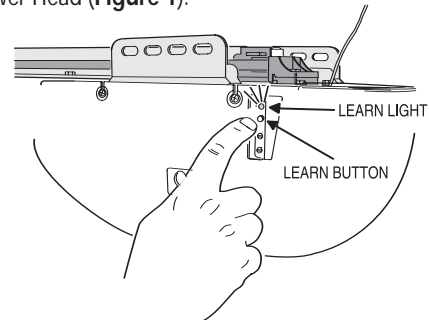

Figure 1 Learn Code Button and Indicator Light

- Press and release Learn Button. Red Learn Indicator Light will blink 2 times per second.
- Press Remote Control Button once within 30 seconds (Figures 2 and 3). Red Learn Indicator Light will stay lit.
- Press Remote Control Button again. Red Learn Indicator Light will go out, indicating that memory is stored.

- B** Program each additional Remote using step A above.

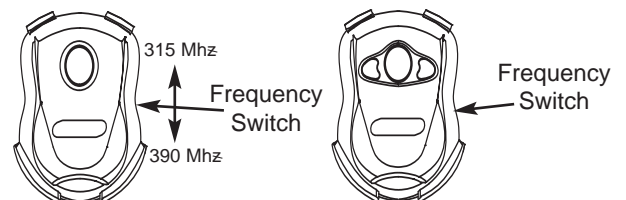

Figure 2 Genie Remote Controls

NOTE

Only one remote button can be entered at a time. Repeat A and B for each remote button to be programmed.

- C Remote Control Operation.
- Press Button on Remote Control. Garage door will move.
 - Press Button again. Garage door will stop:
The door automatically stops at the end of the open or close cycle.
 - Press Button again. Garage door will reverse.
 - Some Remote Controls are equipped with a flashlight. The Genie logo is the button which operates the light. There is a backlight under the button. When it does not light, it indicates the battery needs replaced.

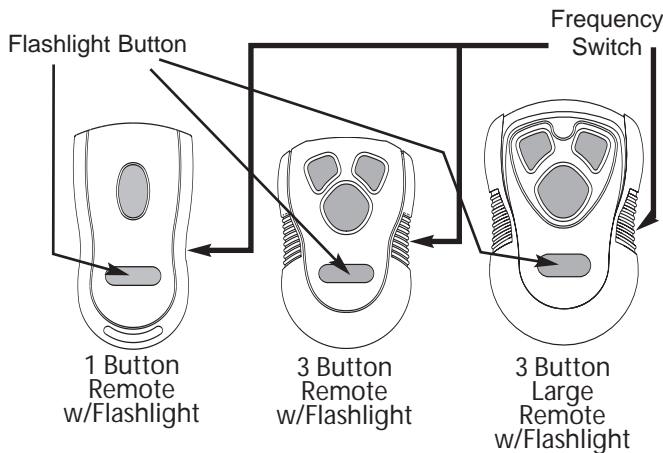

Figure 3 Genie Remote Controls

NOTE

- Each Remote Control must be programmed separately.
- The Remote Controls will not cause the door Opener to close the garage door if the Safe-T-Beam® System is malfunctioning.
- When Programming the Remote Controls, they must be at least 24" from the Antenna Wire.
- If the red Learn Indicator Light blinks approximately 4 times per second, programming has stopped, repeat the above steps.
- Each Button on a 2 or 3 Button Remote Control is for a different Opener. You cannot use more than one Button per Remote, per Opener.
- A maximum of seven Remote Controls or Wireless Keypads can be stored into the Receiver at one time. If a Remote Control becomes lost, or if you want to delete a Remote Control or Wireless keypad, see "To Erase all Receiver Memory"

CAUTION

Should a remote become lost or stolen it is imperative that the remote control codes be erased from the receiver memory and new codes programmed, to prevent the missing remote from being able to operate the door opener.

- D Erasing all remotes (Figure 4).
- Press and hold Learn Button on Power Head until Learn Indicator Light goes out. Memory is erased.
 - Program receiver again as needed.

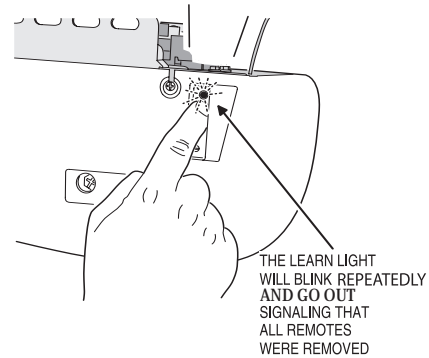

Figure 4 Erasing the remotes

NOTE

If the light on the remote glows dimly or does not light when operating the remote, replace the batteries.

- E Replacing the batteries.
- Pop off the back of the transmitter using a coin.
 - Replace the battery with a new compatible coin type battery. (size 2032)
 - Snap the back of the transmitter on.

Transmitter Compliance Statement

Transmitters comply with all United States and Canadian legal requirements as of the date of manufacture. No warranty is made that they comply with all legal requirements of any other jurisdiction. If transmitters are to be used in another country, the importer must determine compliance with any local laws and regulations which may differ from United States and Canadian requirements prior to use.

Los transmisores cumplen con todas las reglamentaciones legales de los Estados Unidos y del Canadá, en la fecha de fabricación. Ninguna garantía se da que cumplan con todas las reglamentaciones legales de ninguna otra jurisdicción. Si los transmisores se van a utilizar en otro país, el importador debe determinar si cumplen con las reglamentaciones y leyes locales que puedan ser diferentes a las reglamentaciones de los Estados Unidos y del Canadá, antes de usar los mismos.

Les émetteurs sont conformes à la réglementation américaine et canadienne à compter de leur date de fabrication. Aucune garantie n'est stipulée indiquant qu'ils sont conformes à toutes les prescriptions juridiques d'autres autorités. Si les émetteurs sont utilisés dans d'autres pays, il incombe à l'importateur d'en déterminer leur conformité aux lois et règles locales pouvant différer de celles des États-Unis et du Canada avant toute utilisation desdits émetteurs.

Sendegeräte entsprechen allen gesetzlichen Bestimmungen in den USA und Kanada zum Zeitpunkt der Herstellung. Wir übernehmen keine Gewährleistung für die Einhaltung aller gesetzlichen Bestimmungen in anderen Ländern. Sollen Sendegeräte in anderen Ländern eingesetzt werden, so muss der Importeur vor dem Gebrauch sicherstellen, dass die Sendegeräte auch solchen lokalen Bestimmungen entsprechen, welche von den Bestimmungen der USA und Kanadas abweichen.

截止于制造日期,传动装置符合美国和加拿大的所有法律要求。不提供传动装置符合任何其他司法地区所有法律要求之担保。如果传动装置需在任何其他国家使用,进口商必须在使用之前确定装置符合与美国和加拿大要求不同之所有地方法规条例。

トランスミッターは、製造日付けのアメリカ合衆国及びカナダの法的条件に準拠します。しかしながら、トランスミッターがアメリカ合衆国及びカナダ以外の国の法的条件に準拠するか否かは一切保証できません。トランスミッターがアメリカ合衆国及びカナダ以外の国で使用される場合、同製品の使用に先立つ法規制がこれらの国々と異なることがあるため、輸入者は同製品が輸入国の法規制に準拠することを確認しなければなりません。

트랜스미터들은 미국과 캐나다 전역에서 제조 날짜를 명기해야 하는 요구사항에 따라야 합니다. 기타 다른 관할권의 모든 법적인 요구 사항에 따라야 하는 책임은 없습니다. 만일 트랜스미터들이 기타 다른 지역에서 사용될 경우 수입업자는 사용하기에 앞서 미국과 캐나다와의 요구사항과는 다를지도 모르는 그 지역의 법과 조례에 따라야 할지의 여부를 결정해야 합니다.

FCC AND IC CERTIFIED

All devices comply with Part 15 of the FCC Rules. Operation is subject to the following two conditions: (1) this device may not cause harmful interference, and (2) this device must accept any interference received, including interference that may cause undesired operation.

ABOUT DUAL FREQUENCY REMOTE TRANSMITTERS

Your garage door opener (GDO) features a unique dual frequency remote control system for reliable service in today's crowded airwaves. Overcrowded airwaves may intermittently interfere with GDO's remote control system. The dual frequency feature greatly reduces the possibility of unwanted interference.

The receiver in the GDO's powerhead can receive signals at 315 AND 390 MHz. The remote is factory set at 315 MHz. See Figure 2 and 3 on page 11 for frequency selector switch.

Switch your remote control frequency when:

- Remote does not have adequate range.
- Remote works inconsistently with fresh battery installed - LED feedback lights up when pressing button.
- Programming your car's HomeLink® system.

To program a HomeLink® device:

(This GDO is HomeLink® compatible.)

- Use a small flat screwdriver to switch the frequency selector to 390 MHz.
- Follow the HomeLink® instructions in your car owner's manual.
- Reset the remote control frequency to 315 MHz for everyday use.

Step 3: ADJUSTING THE OPEN AND CLOSE LIMITS

⚠ WARNING

Stay clear of the opener's belt, door and all other moving parts during this test.

⚠ CAUTION

Be sure the carriage is disengaged from the belt during the initial limit adjustments. The carriage is disengaged when the release lever is pointing down. DO NOT ENGAGE THE CARRIAGE UNTIL INSTRUCTED.

⚠ CAUTION

Set the Open and Close limits carefully. Setting the limits beyond where the door can physically travel could cause damage to the door, the door hardware or opener.

- A Check that the carriage is disengaged.
- Close the garage door if not already closed
 - Mark the rail at the center of the carriage (**Figure 1**).
- B Manually raise the door to the fully open position. FOR A ONE-PIECE DOOR,, OPEN ONLY UNTIL THE DOOR IS JUST SHORT OF LEVEL.
- Mark the rail at the center of the carriage (**Figure 1**).
 - Manually close the garage door.

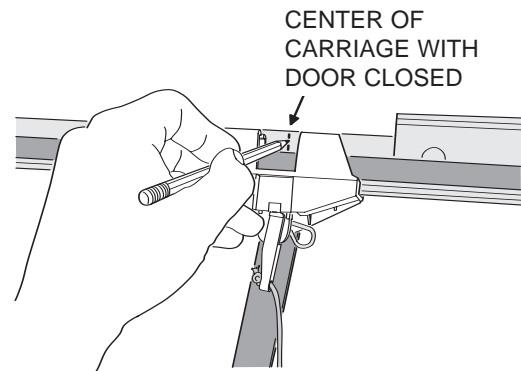

Figure 1 Mark the rail

- C Examine where the carriage stop (**Figure 2**).
- Using a remote to activate the opener.
 - Check where the bullet stops at each end of the rail.

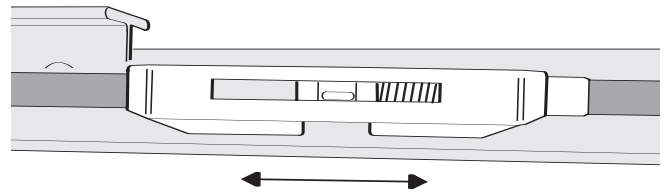

Figure 2 Examine where the carriage stops

NOTE

Repeated activation may cause the opener to thermally shut down (the light will flash 4 times). If so, wait 30 minutes for cool down before continuing.

- D Adjust the open limit (**Figure 3A**).
- Turn the Open Limit Adjustment Screw 1/4 turn at a time toward the up or down to change where the bullet stops.
 - Use the remote to cycle the opener after each adjustment.
 - Adjust until the bullet's leading edge stops at the pencil mark.

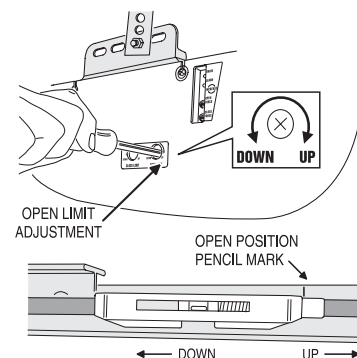

Figure 3A Adjusting the open limit

- E Adjust the close limit (**Figure 3B**).
- Turn the Close Limit Adjustment Screw 1/4 turn at a time toward the up or down to change where the bullet stops.
 - Use the remote to cycle the opener after each adjustment.
 - Adjust until the bullet's leading edge stops at the pencil mark.

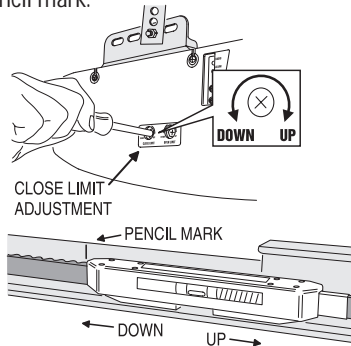

Figure 3B Adjusting the close limit

Step 4: ADJUSTING THE OPEN AND CLOSE LIMITS CONTINUED

NOTE

Each 1/4 turn of the adjustment screw equals about 5/8" of carriage travel.

NOTE

During the next adjustment, if the door stops during opening or reverses during closing before reaching the limits, the door force must be adjusted. Change the door force setting as described in the next section then return here to finish setting these limits.

⚠ WARNING

The door will move during the next adjustment. Stay clear of the door and moving parts

- A Engage the carriage.
- Flip the carriage release lever up and lift the door manually until the carriage engages with the bullet.
- THE FOLLOWING PARAGRAPH IS FOR SECTIONAL DOORS ONLY.
- B Activate the opener using the remote.
- Move the door in the open direction and wait for the door to stop moving (**Figure 1**).
 - Check where the door stopped.
 - Adjust the open limit screw, and repeat cycling the door and making adjustments until it opens fully.

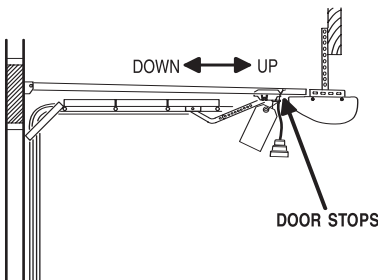

Figure 1 Checking the open limit on sectional

- C Activate the opener using the remote.
- Move the door in the open direction and wait for the door to stop moving (**Figure 2**).
 - Check where the door stopped.
 - Adjust the open limit screw, and repeat cycling the door and making adjustments until it opens to the point where the door is just below level.

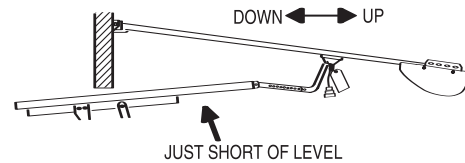

Figure 2 Checking the open limit on one-piece

NOTE

Setting the limit too high on a one-piece door will cause the opener to "buck" when starting down.

- D Activate the opener using the remote.
- Move the door in the close direction and wait for the door to stop.
 - Check where the door stopped.
 - Adjust the close limit screw and repeat cycling the door and making adjustments until it fully closes.

NOTE

If the door is reversing after contacting the floor, the limit is set too far toward the door and needs to be set back.

Step 5: ADJUSTING AND TESTING THE FORCE CONTROLS

⚠ WARNING

Too much force will prevent safe operation of the garage door. Someone could be seriously injured or killed if the door force is set too high. A closing door may not reverse properly and someone could be pinned under it. An opening door might not stop when going up and someone hanging on the door could be pinned between the door and the header. Never increase the force above the minimum required to move the door. Never adjust the force to compensate for a sticking or binding door. Perform this safety check once a month.

⚠ WARNING

Always perform the force check after making any adjustments to the opener.

- A** Locate the CLOSE FORCE adjustment screw (**Figure 1**).
- Use the remote control to cycle the door during these tests.
 - Start with the door open.
 - Turn the close force adjustment screw 1/8-turn at a time in the decrease direction until the door reverses midway while closing.
 - Turn the close force adjustment 1/8-turn at a time in the increase direction until the door fully closes without reversing.

NOTE

Very light, well balanced doors may not be able to be adjusted using the above steps. If so, set the close force to minimum.

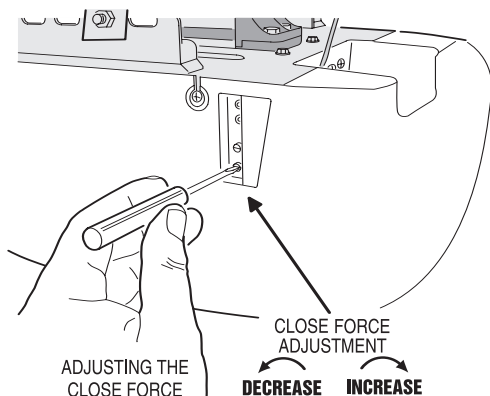

Figure 1 Adjusting close force

NOTE

During the next adjustment, if the door stops during opening or reverses during closing before reaching the limits, the door force must be adjusted. Change the door force setting as described in the next section then return here to finish setting these limits.

TEST THE SAFETY REVERSE

- B** To test the safety reverse (**Figure 2**).
- Open the garage door.
 - Lay a 2" x 4" board flat so it will be struck by the center of the door as it closes.
 - Using the remote control, close the door.
 - The door must reverse within 2 seconds of hitting the board.
 - If the door stops but does not reverse, the close force must be decreased.
 - Repeat this test until the door reverses as required.

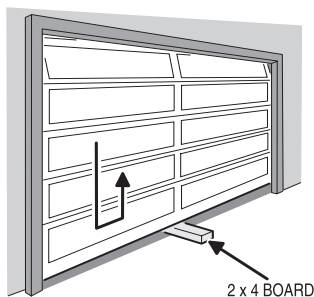

Figure 2 Checking safety reverse

Step 6: ADJUSTING AND TESTING THE FORCE CONTROLS CONTINUED

- A** Locate the OPEN FORCE adjustment screw (**Figure 3**).
- Use the remote control to cycle the door during these tests.
 - Start with the door closed.
 - Turn the open force adjustment screw 1/8-turn at a time in the decrease direction until the door stops midway while opening.
 - Turn the open force adjustment 1/8-turn at a time in the increase direction until the door fully opens without stopping.

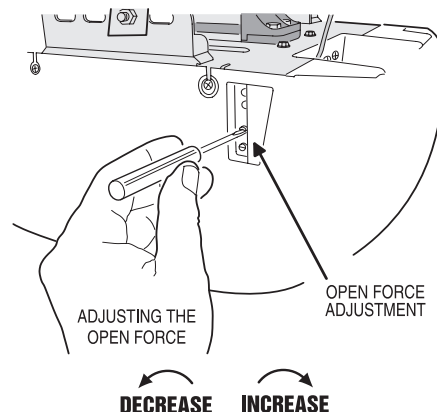

Figure 3 Open force adjustment

IMPORTANT SAFETY INSTRUCTIONS

⚠ WARNING: TO REDUCE THE RISK OF SEVERE INJURY OR DEATH

- 1 READ AND FOLLOW ALL INSTRUCTIONS.
- 2 Never let children operate or play with the Door Controls. Keep the Remote Control away from children.
- 3 Always keep the moving door in sight and away from people and objects until the door is completely closed. NO ONE SHOULD CROSS THE PATH OF A MOVING DOOR.
- 4 NEVER GO UNDER A STOPPED, PARTIALLY OPEN DOOR.
- 5 Test Opener monthly. The door MUST reverse on contact with a 1-1/2" high object (or a 2" x 4" board laid flat) at the center of the doorway on the floor. After adjusting either the Force or the Limit of travel, retest the Door Opener. Failure to adjust the Opener properly may cause severe injury or death.
- 6 When possible use the Emergency Release only when the door is closed. Use caution when using this Release with the door open. Weak or broken springs are capable of increasing the rate of door closure and increasing the risk of severe injury or death.
- 7 KEEP GARAGE DOORS PROPERLY BALANCED. See Owner's Manual. An improperly balanced door increases the risk of severe injury or death. Have a Genie Factory Authorized Dealer make repairs to cables, spring assemblies, and other hardware.
- 8 **SAVE THESE INSTRUCTIONS.**

Step 7: DISENGAGING THE DOOR FROM THE OPENER

- A In case of a power failure or if the door becomes obstructed.
- Pull the red carriage release knob to disengage the carriage from the opener (**Figure 1**).

NOTE

Use caution if the door is open, the door may drop rapidly.

- Flip the carriage release lever up and raise or lower the door to re-engage the opener.

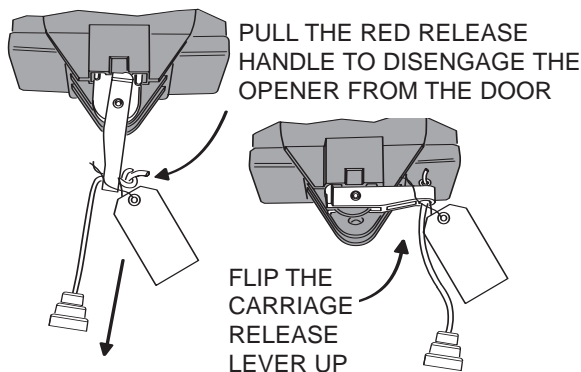

Figure 1 Operating the release mechanism

Step 8: MAINTENANCE

WARNING

Garage door hardware (springs, cables, brackets, pulleys, etc.) are under extreme pressure and tension. **Do not** attempt to adjust any door hardware. Call a qualified garage door installation professional.

WARNING

The garage door opener must not be installed on an unbalanced door. The opener's internal force sensor will not function properly on an unbalanced door. Risk of serious injury or death may result.

WARNING

Always perform the force safety test after making any adjustments to the opener.

CAUTION

Every year, check the door hardware for lubrication needs. Lubricate hinges, rollers and bearings according to manufacturer's recommendation.

PERIODIC MAINTENANCE SCHEDULE

MONTHLY TASKS

- A Check the door's balance
- Close the garage door.
 - Disengage the door from the opener.
 - Raise and lower the door manually.
 - The door should move freely without sticking or binding.
 - Raise the door halfway open.
 - The door should remain relatively still. A slow movement is acceptable.

NOTE

If either of the above tests fail, call a professional garage door installer to repair the door.

- B Test the Safe-T-Beam® System
- Close the garage door.
 - Disengage the door from the opener.
 - Start the opener to run the bullet to the open position.
 - Start the bullet toward the close position and block the Safe-T-Beam®.
 - The bullet should stop and reverse toward the open position.
 - With the beam blocked, verify that constant pressure is required on the wall button to make the bullet move toward the close position.
 - Release the pushbutton before the bullet stops and it should reverse to the open position.
 - Verify that the remote control will not move the bullet in the down direction.
 - If either test fails, adjust the beam and retest. See step 1, page 7.
- C Testing the safety reverse
- Re-engage the door to the opener.
 - Flip the carriage release lever up.
 - Raise the garage door manually until the carriage engages with the bullet.
 - Raise the door to the fully open position.
 - Place a 2" x 4" board flat in the center of the garage door opening.
 - Using the remote or wall button close the door.
 - The door must reverse within 2 seconds of contacting the board.
 - If the test fails, adjust the closing force and retest. (See Step 5, Page 11).

SEMI-ANNUAL TASKS

- A Check the belt tension (**Figure 1**).
- On the bullet, measure the tension spring length.
 - It should be 1".
 - If needed, turn the adjustment wheel until the tension spring is about 1" long.
 - A flat blade screwdriver can be used to turn the adjustment wheel.

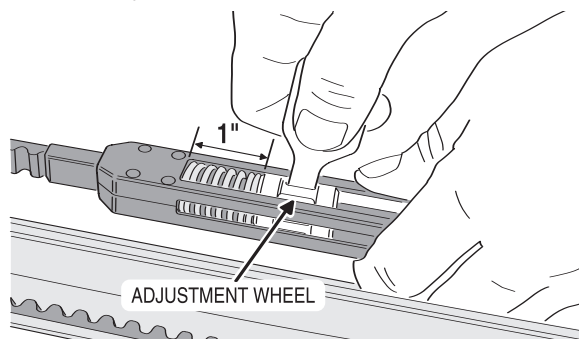

Figure 1 Belt tension

UNSCHEDULED MAINTENANCE

- A** Replacing the Light Bulb.
- To release the light cover.
 - Press in on center tab and lower lens. (Figure 1).
 - Replace the light bulb with a rough service bulb of no more than 100 Watts.
 - Raise Light Cover to close.

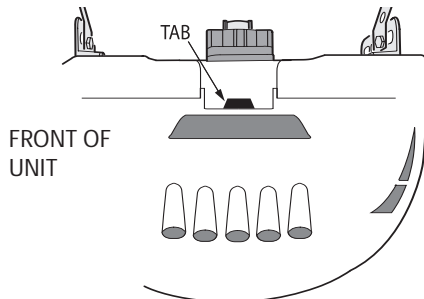

Figure 1 Light Lens

IMPORTANT SAFETY INSTRUCTIONS

⚠ WARNING: TO REDUCE THE RISK OF SEVERE INJURY OR DEATH

- 1 READ AND FOLLOW ALL INSTRUCTIONS.
- 2 Never let children operate or play with the Door Controls. Keep the Remote Control away from children.
- 3 Always keep the moving door in sight and away from people and objects until the door is completely closed. NO ONE SHOULD CROSS THE PATH OF A MOVING DOOR.
- 4 NEVER GO UNDER A STOPPED, PARTIALLY OPEN DOOR.
- 5 Test Opener monthly. The door MUST reverse on contact with a 1-1/2" high object (or a 2" x 4" board laid flat) at the center of the doorway on the floor. After adjusting either the Force or the Limit of travel, retest the Door Opener. Failure to adjust the Opener properly may cause severe injury or death.
- 6 When possible use the Emergency Release only when the door is closed. Use caution when using this Release with the door open. Weak or broken springs are capable of increasing the rate of door closure and increasing the risk of severe injury or death.
- 7 KEEP GARAGE DOORS PROPERLY BALANCED. See Owner's Manual. An improperly balanced door increases the risk of severe injury or death. Have a Genie Factory Authorized Dealer make repairs to cables, spring assemblies, and other hardware.
- 8 **SAVE THESE INSTRUCTIONS.**

⚠ WARNING

Use the Wall Console included with Opener. Any other wall console can cause the Opener to operate unexpectedly and the light to stop working.

TROUBLESHOOTING

IF THERE IS ANY TROUBLE WITH THE OPENER, TRY THESE SOLUTIONS BEFORE CALLING THE HELP NUMBER.

NOTE

In all cases, watch the opener's lights for any flashing trouble codes. Refer to the Flashing Light Trouble Codes on page 16 for the problem cause and remedy.

Trouble 1: OPENER DOES NOT OPERATE FROM THE REMOTE OR WALL CONTROL

- A** Check that the opener's AC outlet has power. Plug a lamp into the outlet to check.
- B** The motor's automatic thermal shutoff switch may have been activated from repeated use (opener's lights will flash 4 times). Wait 30 minutes for the motor to cool down and retry.
- C** Check the wall control wiring at the wall control's and opener's terminals and be sure that the remote is programmed into the opener.

Trouble 2: OPENER TRIES TO OPERATE, BUT THE DOOR DOES NOT MOVE

- A** A door spring may have broken. Visually inspect the door hardware for any broken springs. Have a qualified garage door service professional repair the door if any hardware is broken.
- B** In cold weather climates, check that the door is not frozen to the ground or that snow buildup is not blocking the door.
- C** If the opener light flashes 4 times, the door force setting may be too low. Adjust the force.

Trouble 3: OPENER OPERATES, BUT THE DOOR DOES NOT MOVE

- A** Check that the carriage is engaged to the bullet/belt. The carriage release lever must be in the horizontal position in order for it to engage.

Trouble 4: THE DOOR STARTS TO OPEN BUT STOPS BEFORE FULLY OPENING

- A** If the opener light flashes 4 times, the open force setting may be too low. Reset the force.
- B** The door hardware may be binding causing the door force setting to be exceeded. Disengage the carriage and manually check the door movement and balance. Lubricate the door hardware as recommended by the manufacturer.

Trouble 5: THE DOOR DOES NOT OPEN COMPLETELY

- A** Adjust the open limit setting.

Trouble 6: THE DOOR DOES NOT CLOSE COMPLETELY

- A** Adjust the close limit setting.

Trouble 7: THE DOOR STARTS TO CLOSE BUT REVERSES BEFORE FULLY CLOSING

- A If the opener light flashes 4 times, the close door force setting may be too low.
- B The door hardware may be binding causing the door force setting to be exceeded. Disengage the carriage and manually check the door movement and balance. Lubricate the door hardware as recommended by the manufacturer.
- C The Safe-T-Beam® has been interrupted while the door is closing (opener light flashes 3 times), or the Safe-T-Beam® is out of alignment.

Trouble 8: OPENER LIGHTS STAY ON

- A It is normal for the lights to stay on for about 5 minutes after being activated.
- B If the lights were turned on using the light button on the wall control, they will stay on until they are turned off using the wall control light button or the door is cycled open or shut.

Trouble 9: OPENER DOES NOT OPERATE FROM THE WALL CONTROL, BUT DOES FROM THE REMOTE

- A Check the wall control wiring at the wall control and opener terminals.
- B Check the wiring between the wall control and the opener. Look for any staples that have cut into the wire's insulation or wire that has been pinched. If the opener light flashes 2 times when the remote is used, the wall control wires are shorted and the bad section must be replaced.

Trouble 10: OPENER DOES NOT OPERATE FROM THE REMOTE, BUT DOES WITH THE WALL CONTROL

- A Be sure that the remote is programmed into the opener.
- B Check the remote's battery. The red light should light up when ever the remote button is pressed.

Trouble 11: OPENER CLOSES, BUT DOES NOT OPEN WITH THE REMOTE

- A If the opener lights flash 5 times when the remote is activated, and the door does not open, the vacation switch is on. Turn the vacation switch off (optional accessory).

Trouble 12: REMOTE CONTROL WILL NOT OPERATE AT A DISTANCE FROM THE OPENER.

- A Be sure that the opener's antenna (the short white wire on the back of the opener) is extended upward from the opener.
- B Check the remote's battery.
- C Remote control operating distance will vary depending on the amount of interference and metal obstacles in the path of the signal.

Trouble 13: OPENER RUNS BY ITSELF

- A Examine all remotes programmed into the opener. Check for items that might be pressing on a remote button. Look for remotes stuffed between seat cushions of the car.
- B If a remote has been lost or stolen, erase the opener's memory to prevent the missing remote from activating the opener. Reprogram the remaining remotes into the opener.
- C Check the wiring between the wall control and the opener. Look for staples that have cut into the wire's insulation, or wire that has been pinched by a object. Replace any bad wire.
- D Examine the wiring at the opener's terminals and the wall control terminals. Look for any wires that are close to or touching adjacent terminals.

Trouble 14: OPENER IS NOISY

- A Lubricate the door hardware as recommended by the garage door manufacturer.

Trouble 15: THE OPENER WILL NOT OPERATE BECAUSE OF A POWER FAILURE

- A Pull the carriage release handle to disengage the opener from the door. The door can be operated manually until power is restored.

FLASHING LIGHT TROUBLE CODES

Power Head System Status

NUMBER OF FLASHES	PROBLEM	CAUSE	REMEDY
2 FLASHES	Door won't close	Shorted wall control wire	Check wall control wires. Be sure both are connected to terminal screws. Check for a staple in the wires. Remove any staples compressing the wire.
3 FLASHES	Door won't close	Safe-T-Beam® obstacle	Check for obstacles. Align the Safe-T-Beam®
4 FLASHES	Door reverses or won't open or close	Open or close force exceeded, or motor exceeded, or motor thermal shutdown	Check for binding or unbalanced door. Adjust the door force. If the motor had thermal shutdown, wait 30 minutes and retry.
5 FLASHES	Door won't open with remote	Remote control was activated while vacation switch was locked	Unlock the vacation switch on the wall control (optional accessory)
6 FLASHES	Motor ran longer than 30 seconds	Mechanical or electronic failure	Call Customer Service 800-354-3643

PARTS IDENTIFICATION

FULL ASSEMBLY

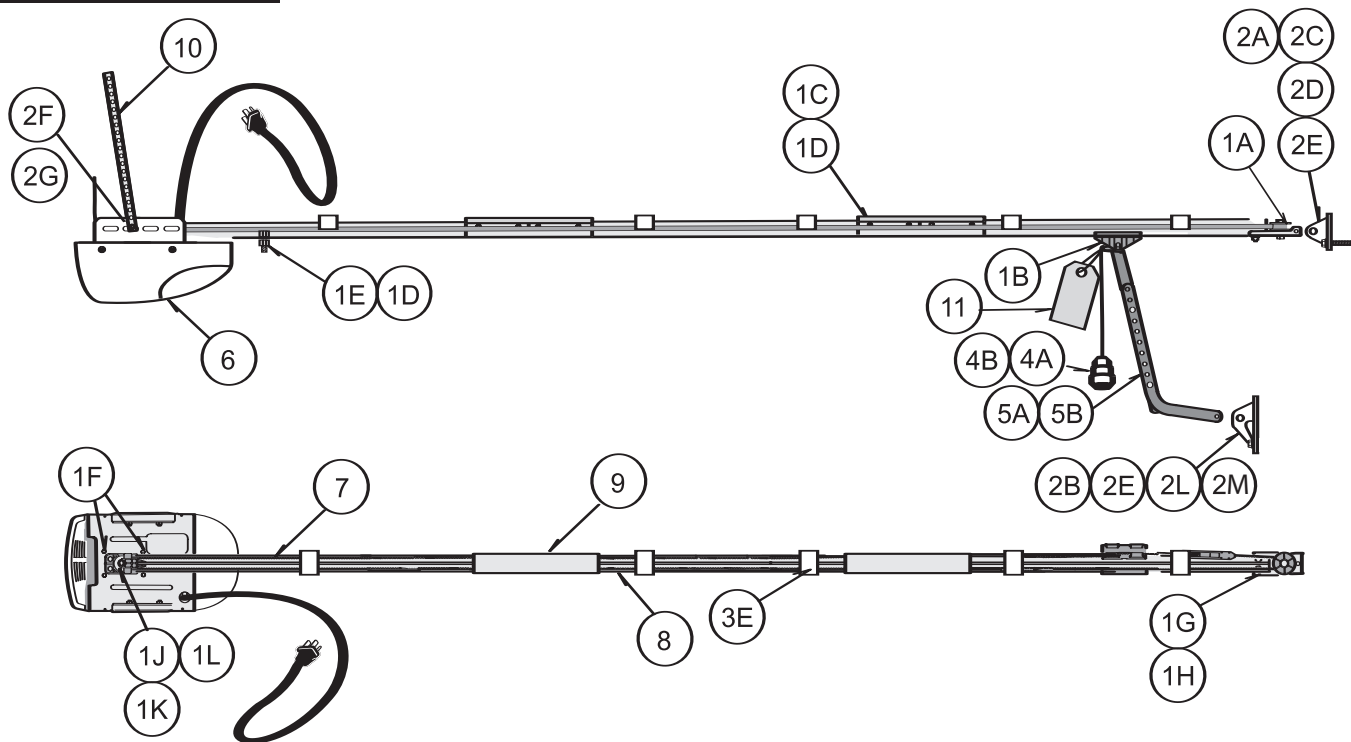

Parts List

Item	Part Name	Number Included
1A	Pulley Assembly	1
1B	Carriage	1
1C	Carriage Bolt, 1/4"-20 x 3/4"	8
1D	Locknut, 1/4"-20	9
1E	Flange Bolt, 1/4"-20 x 1/2"	1
1F	Tapered Flange Bolt, 1/4"-20 x 3/4"	4
1G	Bolt, 5/16"-18 x 3/4"	2
1H	Locknut, 5/16"-18	2
1J	Sprocket	1
1K	Sprocket Holder	1
1L	Belt Clamp	1
1M	Grease, Tube	1
2A	Header Bracket	1
2B	Door Bracket	1
2C	Lag Screw, 5/16" x 2"	4
2D	Clevis Pin, 2-3/8"	1
2E	Cotter Pin	3

Parts List

Item	Part Name	Number Included
2F	Bolt, 5/16"-18 x 1"	6
2G	Locknut, 5/16"-18	6
2K	Clevis Pin, 1-3/8"	1
2L	Clevis Pin, 1-1/8"	1
2M	Self Tappers	4
3A	Safety Beam Bracket (not shown)	4
3B	Safety Beam Transmitter (not shown)	1
3C	Safety Beam Receiver (not shown)	1
3D	Wire, 22 AWG, 2-cond. (not shown)	90 ft.
3E	Wire Clip	5
3F	Flange Bolt, 1/4"-20 x 1/2"	2
3G	Lag Screw, 1/4" x 1-1/4"	4
3H	Locknut, 1/4"-20	2
3J	Insulated Staples	20
4A	Carriage Release Handle	1
4B	Release Handle Rope	36"
4C	Wall Control (not shown)	1

Parts List

Item	Part Name	Number Included
4D	Machine Screw, 6-32 x 1"	2
4E	Wood Screw, #6 x 1"	2
4F	Screw Cover	2
4G	3-Button Remote Control	2
4H	Wireless Keypad	1
4J	Screw Anchor	2
4K	Wood Screw, #6 x 1-1/2"	2
4L	Screw Cover	2
5A	Straight Door Arm	1
5B	Curved Door Arm	1
6	Motor Head	1
7	Rail Assembly (3 sections)	1
8	Belt	1
9	Rail Clamps	2
10	Mounting Strap	2
11	Emergency Release Tag	1

Free Manuals Download Website

<http://myh66.com>

<http://usermanuals.us>

<http://www.somanuals.com>

<http://www.4manuals.cc>

<http://www.manual-lib.com>

<http://www.404manual.com>

<http://www.luxmanual.com>

<http://aubethermostatmanual.com>

Golf course search by state

<http://golfingnear.com>

Email search by domain

<http://emailbydomain.com>

Auto manuals search

<http://auto.somanuals.com>

TV manuals search

<http://tv.somanuals.com>