



Statement

BTS-400, 300, 486 offer a function that the relay output model & LED brightness setting can be adjusted. When a finger is touched on the board (or pushing the button), it acts the internal relay output, with adjustable timer (1~30 seconds). It includes a selection of touch panel and touch button switch that making the user easy to use, especially when wearing gloves. The relay is available in Com-N. C. and Com-N. O model. There are 6 X 2 levels of LED light available.

Specifications

- Adjustable switch delay timer (1 to 30 seconds)
- SPDT relay rating: 3A@ 125V~
- Current: 60mA~100mA@12V DC
- Power input : 12~24 V DC
- Bi-LED backlight indicate power & status
- Beeper sounds when relay activated
- Operating Temper.: - 20~+70C
- JP setting:
 - JP1: Relay output model
 - JP2: LED lighting or blinking setting
 - JP3~5: LED brightness setting



GIANNI INDUSTRIES, INC.

No. 13, Zhong Sing Road, Tu-Cheng Industrial Zone,
Tu-Cheng City, Taipei, Taiwan 23678
Tel: 886-2 2267 7986 / Fax: 886-2 2267 9876
E-Mail: info@gianni.com.tw
Website: gianni.tw
Copyright 2008 Gianni industries, inc. All rights reserved.
DM-CA-BTS Ver. E Published on 2008.07.07

Application

BTS-486

Relay output model control and LED brightness setting

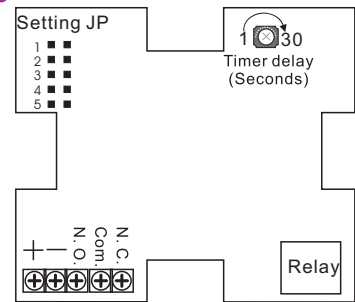

BTS-400-ANSI/300

Relay contact output (free voltage contact)

12~24VDC power input

Relay output model control and LED brightness setting

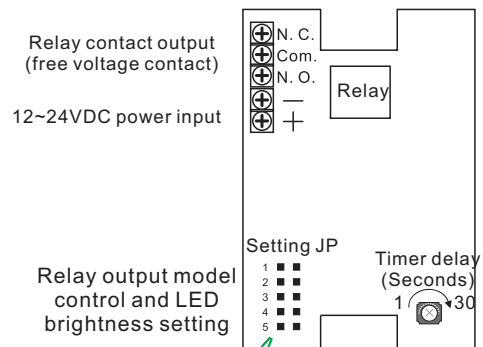

1 ■ ■	Relay output Com.—N. C. (Touched)	Relay output Com.—N. O.
1 ■ ■	Relay output Com.—N. O. (Touched)	Relay output Com.—N. C.
2 ■ ■	(Light is lighting)	
2 ■ ■	(Light is blinking.)	
3 ■ ■ 4 ■ ■ 5 ■ ■	(Green) (Touched)	(Red)
3 ■ ■ 4 ■ ■ 5 ■ ■	(Red) (Touched)	(Green)
3 ■ ■ 4 ■ ■ 5 ■ ■	(Green) (Touched)	(Light is lighting)
3 ■ ■ 4 ■ ■ 5 ■ ■	(Light is lighting) (Touched)	(Green)
3 ■ ■ 4 ■ ■ 5 ■ ■	(Red) (Touched)	(Light is lighting)
3 ■ ■ 4 ■ ■ 5 ■ ■	(Light is lighting) (Touched)	(Red)



The products are manufactured under an ISO 9001 & QC 080000 Certified Quality Management Program environment back its product quality, performance and commitment to customer satisfaction.

BTS-486

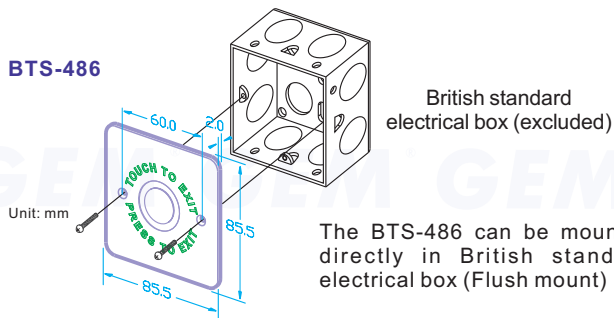

Surface mounting Installation: SMB-86ALU housing is optional for surface mount.

BTS-300

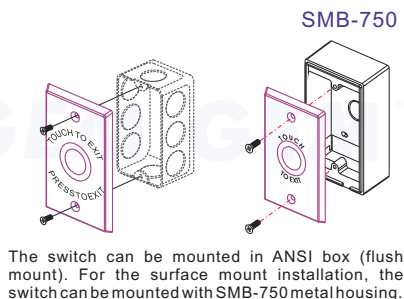
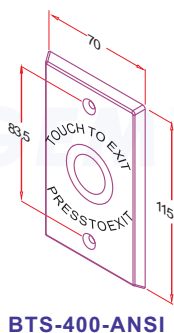
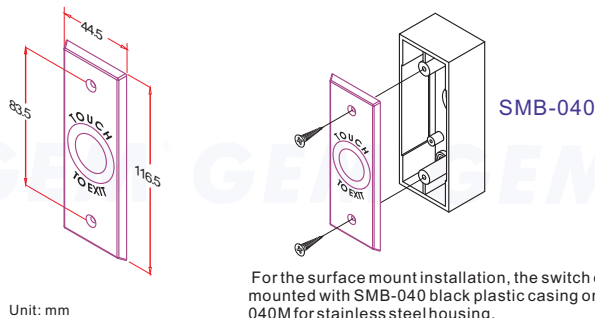

The touch sensitive switch is when a finger (or metal object) is touched on the board, it acts the internal relay output (N/C to N/O contact), with adjustable timer (1~30 seconds).

Surface mount



Specifications

- Power input:
BTS-100, 200: 12 V DC
BTS-85UK, 115, 300, 400: 12~24 V DC
- Current : Stand by :30 mA at 12VDC, Active: 50 mA at 12VDC
- Adjustable switch delay timer (1 to 30 seconds)
- SPDT relay rating: 3A@ 24V
- Selectable time range: 1 to 30 seconds
- 2 LEDs indicate power & status
- Beeper sounds when relay activated
- Operating Temper.: - 20~+70C

GIANNI INDUSTRIES, INC.

No. 13, Zhong Sing Road, Tu-Cheng Industrial Zone,
Tu-Cheng City, Taipei, Taiwan 23678
Tel: 886-2 2267 7986 / Fax: 886-2 2267 9876
E-Mail: info@gianni.com.tw
Website: gianni.tw
Copyright 2008 Gianni industries, inc. All rights reserved.
DM-CA-BTS Ver. E Published on 2008.07.07



The products are manufactured under an ISO 9001 & QC 080000 Certified Quality Management Program environment back its product quality, performance and commitment to customer satisfaction.

BTS-100

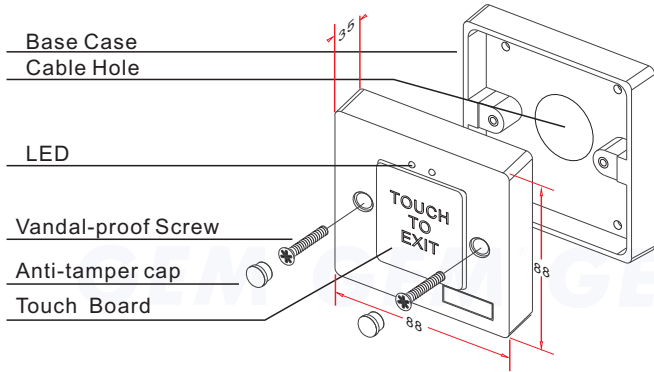

BTS-115-S

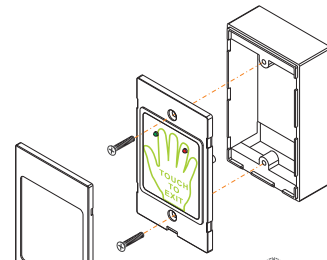

BTS-115-ANSI

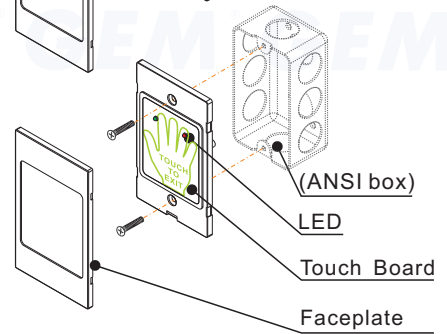

BTS-200

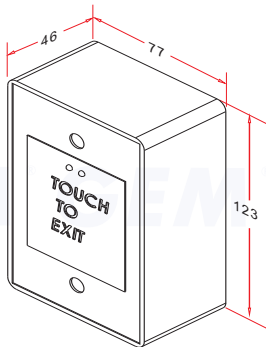

BTS-85UK

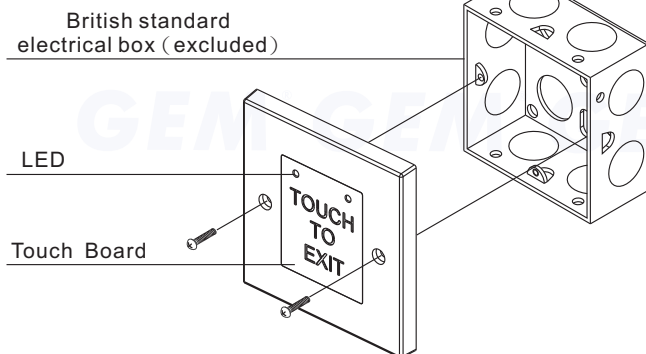

● Warranty

The product is warranted against defects in material and workmanship while used in normal service for a period of 1 year from the date of sale to the original customer. The GEM policy is one of continual development and improvement; therefore GEM reserves the right to change specifications without notice.

GIANNI INDUSTRIES, INC.

No. 13, Zhong Sing Road, Tu-Cheng Industrial Zone,
Tu-Cheng City, Taipei, Taiwan 23678
Tel: 886-2 2267 7986 / Fax: 886-2 2267 9876
E-Mail: info@gianni.com.tw
Website: gianni.tw
Copyright 2008 Gianni industries, inc. All rights reserved.
DM-CA-BTS Ver. E Published on 2008.07.07



The products are manufactured under an ISO 9001 & QC 080000 Certified Quality Management Program environment back its product quality, performance and commitment to customer satisfaction.

Free Manuals Download Website

<http://myh66.com>

<http://usermanuals.us>

<http://www.somanuals.com>

<http://www.4manuals.cc>

<http://www.manual-lib.com>

<http://www.404manual.com>

<http://www.luxmanual.com>

<http://aubethermostatmanual.com>

Golf course search by state

<http://golfingnear.com>

Email search by domain

<http://emailbydomain.com>

Auto manuals search

<http://auto.somanuals.com>

TV manuals search

<http://tv.somanuals.com>