

Model MP4130HT(C)

Triplex Ceramic
Plunger Pump
Operating Instructions/
Repair and Service
Manual

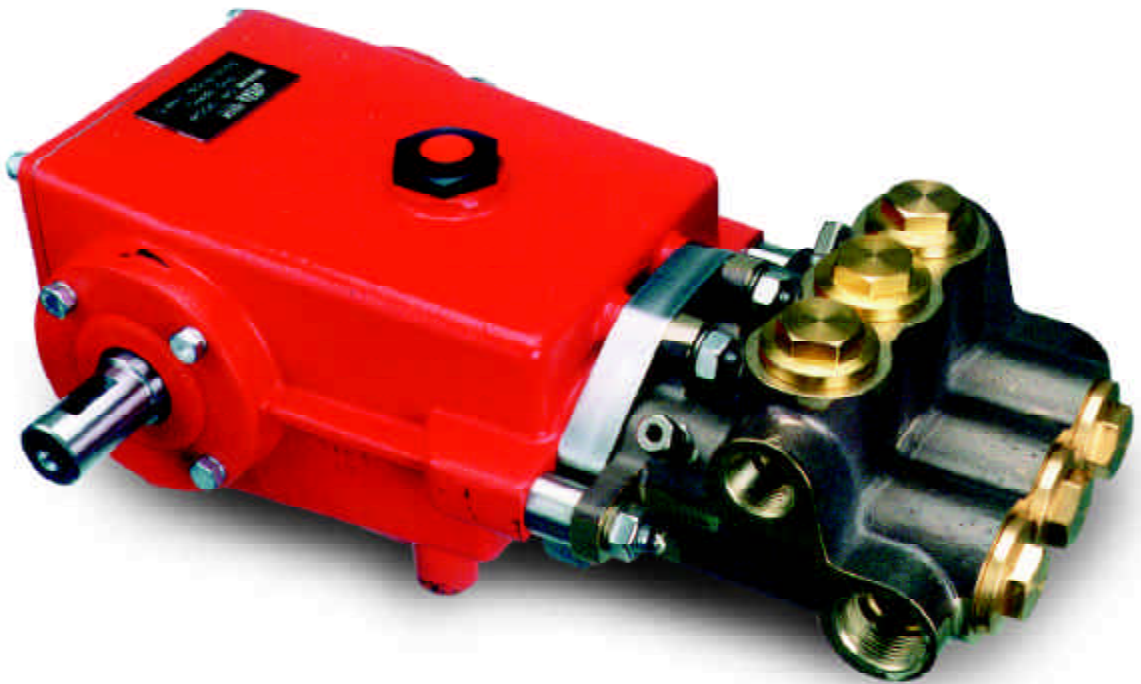

GIANT

Contents:

Installation Instructions:	page 2
Pump Specifications:	pages 3
Exploded View:	page 4
Parts List / Kits:	page 5
Repair Instructions:	page 6-10
Torque Specifications:	page 10
Trouble Shooting:	page 11
Dimensions:	back page
Warranty Information:	back page

INSTALLATION INSTRUCTIONS

Installation of the Giant Industries, Inc., pump is not a complicated procedure, but there are some basic steps common to all pumps. The following information is to be considered as a general outline for installation. If you have unique requirements, please contact Giant Industries, Inc. or your local distributor for assistance.

The MP4130HT has been especially constructed for pumping hot water e.g. steam boiler storage. The plunger seals (40) on the water side are made out of a high temperature-resistant material. Rinsing chambers behind the high pressure seals through which cold water can flow thus increasing the life of the seals are available upon request (MP4130HTC). The cold water connections (59) are suited to the Ermeto-pipe 6mm dia. The operator can use hose nipples instead if he wishes. There are 1/8" threads in the seal sleeve for this purpose. The cold water (50°F - 86°F) can be guided into the pump from either side and flows out on the opposite side e.g. into a drain. The cold water flow rate should be at least 0.13 GPM and must be put into use as soon as the pump is

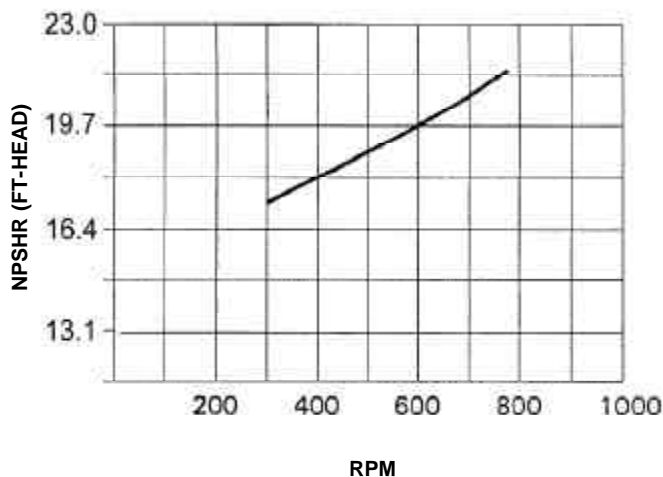

Finally, remember that high pressure operation in a pump system has many advantages. But, if it is used carelessly and without regard to its potential hazard, it can cause serious injury.

IMPORTANT OPERATING CONDITIONS

Failure to comply with any of these conditions invalidates the warranty.

1. Prior to initial operation, add oil to the crankcase so that oil level is between the two lines on the oil dipstick. **DO NOT OVERFILL.**

Use SAE 85W - 140 Industrial Gear Oil.

Crankcase oil should be changed after the first 50 hours of operation, then at regular intervals of 500 hours or less depending on operating conditions.

2. Pump operation must not exceed rated pressure, volume, or RPM. A pressure relief device must be installed in the discharge of the system.

3. Acids, alkalines, or abrasive fluids cannot be pumped unless approval in writing is obtained before operation from Giant Industries, Inc.

4. Run the pump dry approximately 10 seconds to drain the water before exposure to freezing temperatures.

started. If the cold water doesn't start flowing immediately the pump is put into operation, the ceramic plunger (29B) in particular, could crack under the cold shock.

Important! If the location of the pump doesn't allow for cooling, on no account are the connections to be closed up because this is where water from the high pressure seals has to drip out. In this case, the holes can be used to fill the rinsing chambers with grease suitable for high temperatures, by means of a grease gun, thus assuring that the seals are always well greased. In the case of water temperature above 32°F, we strongly recommend the cold-water rinse.

Plant Lay-Out

For perfect functioning of the pump, the following points must be adhered to.

a) Pressure in Suction Side

The stipulated NPSHR is the minimum required pressure above vapour pressure of the medium and is never to fall short of this figure. Temperature and vapour pressure of the medium, the geodetical height of the location, the flow rate and loss of friction in the suction line, must all be taken into consideration. It may be necessary to install a booster pump (centrifugal pump) in the suction line.

b) Pulsation

Due to its construction, the plunger pump creates pulsation in the suction and discharge lines. Suction pulsation in particular must be dampened in order to prevent resonance in the suction line which in turn, causes cavitation. Therefore, the pump is never to be connected by a rigid pipe but rather by a flexible hose (not reinforced by steel), and if possible 1.5 to 2 times wider than the suction connection. If a booster pump is used, the hose is to be attached between the booster pump and the high pressure pump.

If several pumps are used, each pump must have its own suction line. If this can't be done, a suction air chamber or a suction flow stabilizer must be installed in front of each pump. The bladder in the stabilizer is to be pretensioned on location.

Depending on the lay-out of the plant, a pressure accumulator may be necessary on the discharge side. This pressure accumulator must be installed right behind the discharge outlet of the high pressure pump. We recommend the use of only one pressure accumulator in discharge line in order to avoid irritation which could be caused by the different pre-tension levels in the accumulators. Gas-tension in both the suction flow stabilizer and in the pressure accumulator are to be checked regularly.

Specifications

Model MP4130HT(C)

Volume	Up to 629 GPH (10.5 GPM)
Discharge Pressure.....	Up to 1200 PSI
Inlet Pressure.....	See NPSHR chart (pg.2)
Speed	Up to 750 RPM
Plunger Diameter	30mm
Plunger Stroke	26mm
Crankcase Oil Capacity	32 fl.oz.
Temperature of Pumped Fluids	Up to 220 °F
Inlet Ports	(2) 1" BSP
Discharge Ports	(2) 3/4" BSP
Pulley Mounting	Either side
Shaft Rotation	Top of Pulley Towards Fluid End
Weight	72 lbs.
Crankshaft Diameter	28mm

PULLEY INFORMATION

Pulley selection and pump speed are based on a 1725 PRM motor and "B" section belts. When selecting desired GPM, allow for a ±5% tolerance on pumps output due to variations in pulleys, belts and motors among manufacturers.

1. Select GPM required, then select appropriate motor pulley from the same line.
2. The desired pressure is achieved by selecting the correct nozzle size that corresponds with the pump GPM.

HORSEPOWER INFORMATION

We recommend that a 1.1 service factor be specified when selecting an electric motor as the power source. To compute specific pump horsepower requirements, use the following formula:

$$HP = (GPM \times PSI) / 1440$$

MP4130HT(C) PULLEY SELECTION AND HORSEPOWER REQUIREMENTS									
PUMP PULLEY	MOTOR PULLEY	RPM	GPM	GPH	300 PSI	600 PSI	725 PSI	900 PSI	1200 PSI
9.75"	2.50"	400	5.6	335	1.2	2.3	2.8	3.5	4.7
9.75"	3.00"	500	7.0	419	1.5	2.9	3.5	4.4	5.8
9.75"	3.60"	600	8.4	503	1.8	3.5	4.2	5.3	7.0
9.75"	4.15"	700	9.8	587	2.0	4.1	4.9	6.1	8.2
9.75"	4.45"	750	10.5	629	2.2	4.4	5.3	6.6	8.8

Exploded View - MP4130HT(C)

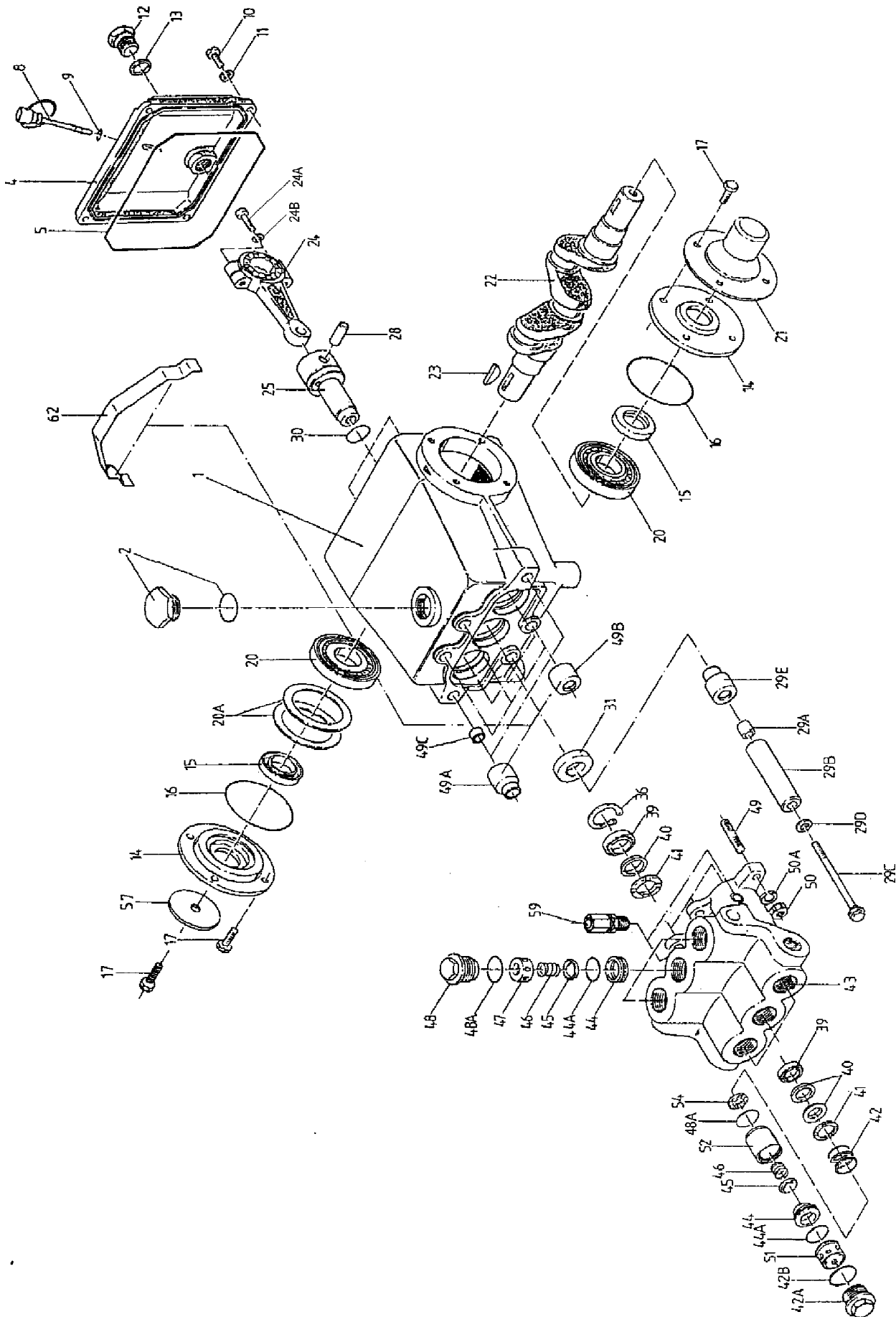

MP4130HT(C) PARTS LIST

<u>ITEM</u>	<u>PART#</u>	<u>DESCRIPTION</u>	<u>QTY.</u>	<u>ITEM</u>	<u>PART#</u>	<u>DESCRIPTION</u>	<u>QTY.</u>
1	06100	Crankcase	1	36	07267	Snap Ring	3
2	13000	Oil Filler Plug Assembly	1	39	07271	Pressure Ring	6
4	07243	Cover, Crankcase	1	40	06137	V-Sleeve	9
5	07244	O-Ring	1	41	07273	Support Ring	6
8	01008	Oil Dip Stick Assembly	1	42	07353	Tension Spring	3
9	01009	O-Ring, Dip Stick	1	42A	06103	Tension Plug, M42 x 1.5	3
10	01010	Screw, Crankcase Cover	4	42B	07354	O-Ring	3
11	01011	Spring Washer	4	43	06138	Valve Casing	1
12	07109	Oil Drain Plug, G 1/2"	1	44	07280	Valve Seat	6
13	07182	Gasket	1	44A	07281	O-Ring	6
14	07245	Bearing Cover	2	45	07282	Valve Plate	6
15	07247	Seal, Crankshaft	2	46	07283	Valve Spring	6
16	07627	O-Ring	2	47	07284	Spring Retainer, Discharge	3
17	07114	Hex Screw, Bearing Cover	9	48	07356	Plug, Brass, M36 x 1.5	3
20	07248	Roller Bearing, Tapered	2	48A	07332	O-Ring	6
20A	07249	Fitting Disc	2	49	06139	Stud Bolt	6
21	07250	Shaft Protector	1	49A	06140	Fitting Sleeve with Extension	2
22	07251	Crankshaft	1	49B	06141	Extension	4
23	07252	Key	1	49C	07289	Centering Sleeve	2
24	07253	Connecting Rod	3	50	13042	Hexagon Nut	6
24A&B	07122	Hex Screw w/washer	6	50A	13043	Disc	6
25	07254	Crosshead, Complete	3	51	06110	Spacer Pipe	3
28	07255	Crosshead Pin	3	52	06112	Inlet Valve Housing	3
29A	07256	Centering Sleeve	3	54	06115	Inlet Spring Tension Disc	3
29B	07261	Plunger Pipe	3	55	12249	Plug, G 1"	1
29C	06134	Tension Screw	3	56	12248	Plug, G 3/4"	1
29D	13008	Copper Ring	3	57	13020	Disc for Crankshaft	1
29E	06135	Plunger Extension	3	59	06588	Screw-In Pipe Connection	2
30	06136	Oil Scraper	3	62	06142	Tin Lid	1
31	07260	Crankcase Oil Seal	3				

MP4130HT(C) REPAIR KITS

Seal Repair Kit

Part # 09532

<u>Item #</u>	<u>Qty.</u>	<u>Part #</u>	<u>Description</u>
40	9	06137	V-Sleeve
42B	3	07354	O-Ring

Valve Assembly Kit

Part # 09533

<u>Item #</u>	<u>Qty.</u>	<u>Part #</u>	<u>Description</u>
44	6	07280	Valve Seat
44A	6	07281	O-Ring
45	6	07282	Valve Plate
46	6	07283	Valve Spring
47	3	07284	Spring Retainer, Discharge
48A	3	07332	O-Ring
54	3	06115	Inlet Spring Tension Disc

REPAIR INSTRUCTION - MP4130HT(C)

Disassembly sequence of the GIANT MP4130HT(C) Series Pumps



1. With a 27mm wrench, remove the three discharge plugs (#48) and three inlet plugs (#42A) from the manifold (#43).



2. Inspect the plug o-rings (#48A and #42B) and replace as necessary.



3. Using a valve puller (available from Snap-On-Tools), remove the valve assembly (#44 - #47).

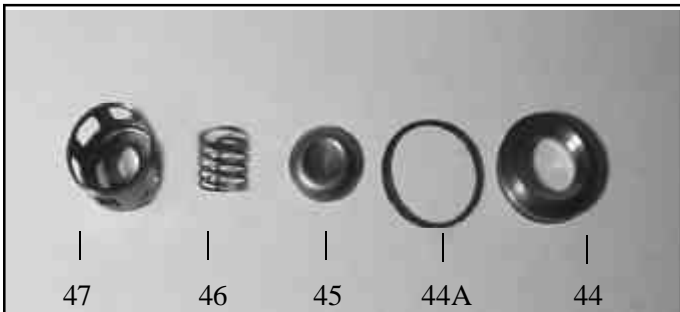

4. Inspect all parts, especially the seating surface of the valve plate (#45), and replace as necessary.



5. Remove the six manifold stud nuts (#50) with a 19mm wrench. Remove the spring washers (#50A). Tap the back of the manifold with a rubber mallet to dislodge and slide it off the studs (#49).



6. To remove the inlet valve assembly, insert a 13mm socket with extension through the rear of the inlet manifold (#43) port and tap it firmly with a hammer. This will force the tension spring (#46), valve housing (#52) and the remainder of the inlet valve assembly out through the front of the inlet port.

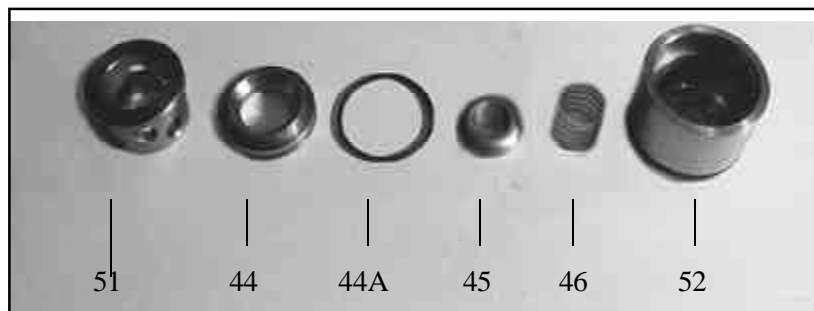

7. Pull the inlet valve assembly apart for inspection. Any resistance may be overcome by placing the valve housing (#52) in a brass jawed vise and carefully tapping the back of the valve plate (#45) with a screwdriver. Remove the spacer pipe (#51) valve seats (#44), o-ring (#44A), valve plate (#45), spring (#46), replace them as necessary.

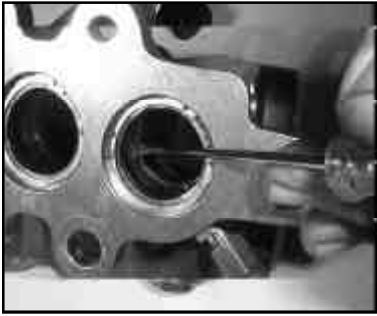

8. From the back of the manifold (#43), remove the packing assembly (#'s 42, 41, 40, and 39) by tapping assembly out from the back to the front.

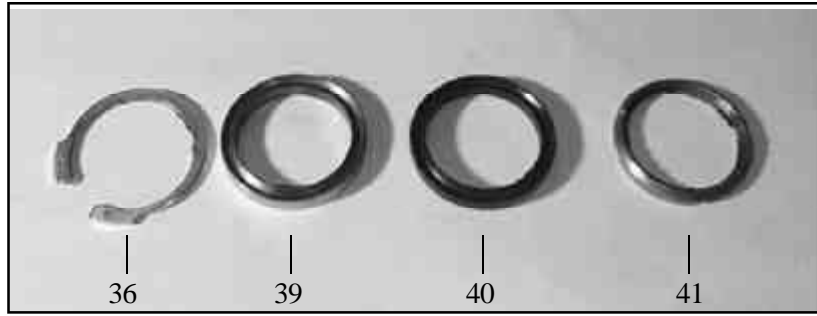

9. Turn the manifold (#43) over and remove the rear v-sleeve snap ring (#36). Remove rear pressure ring (#39), rear v-sleeve (#40) and rear support ring (#41). These parts should slide out with little resistance. If necessary, a screwdriver may be used to pry outward. Replace all rubber parts and inspect the metal parts for wear.

10. **Note: The following procedure is only necessary if a stud bolt (#49) has been damaged and must be replaced.** To remove the manifold studs (#49), place a stud nut (#50), lock washer (#50A), and second nut on each stud. Tighten the nuts against each other. Hold the front nut with one wrench, and remove the stud bolt by turning the rear nut counterclockwise with another wrench. To reassemble, turn the front stud bolt nut clockwise.

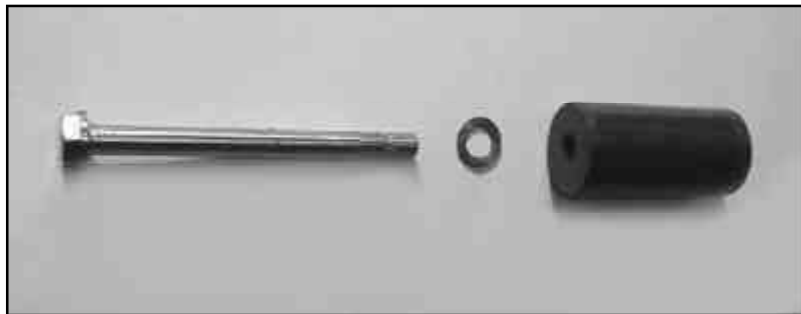

11. To remove the ceramic plungers, turn the plunger bolt (#29C) counterclockwise with a 13mm socket. Use a steady torque to prevent ceramic plunger sleeve damage. Loosen and remove the plunger bolt assembly (#29C and #29D) and replace the seal washer (#29D).



11a. Inspect the crankcase oil seals (#31) for evidence of leaking. If there is oil on the crankcase (#1) at the sight of the oil seals, they must be replaced. The oil seals are replaced after removing the crosshead/plunger assembly (#25) as described below.

Contact Giant Industries for service school information. Phone: (419) 531-4600

Gear End Disassembly

Note: Make certain that the plungers (29B) have been removed before starting the following sequence.

12. Make sure the oil is drained from the pump before removing the crankcase cover (#4). Remove all screws (#10). Inspect the crankcase cover o-ring (#5) for damage and replace it as necessary.
13. Remove the connecting rod screws and washers (#s 24A and 24B) with a 6mm allen wrench. Remove the back halves of each connecting rod (#24) . Push the connecting rods down as far as possible into the crankcase (#1) housing. **Note that the connecting rod halves are numbered (or colored) and that the numbers (or colors) must be matched for reassembly.**
14. Remove the crankshaft bearing cover screws (#17) with a 13mm wrench. Remove the key (#23) from the crankshaft (#22).
15. Remove the bearing cover (#14) and any shims (#20A) if any. **Remember to replace shims on the same side of the crankcase (#1) during the reassembly.**
16. Steady the pump gear end and, using a rubber mallet, tap the crankshaft (#22) from one side. The far side bearing race will be removed and the near side race will remain in the crankcase. The roller bearings (#20) will remain on the crankshaft. When both ends are free, the crankshaft can be removed by hand.
17. To remove the remaining bearing race, place a dowel against the inside edge of the race and tap it out with a rubber mallet. This is done only if the race wear surface has been damage.
18. Inspect the bearing race removed with the crankshaft (#22) and replace if wear surface is damaged.
19. **Note: The following procedure is only necessary if the inspection shows evidence of heavy wear.** Inspect the crankshaft (#22) and bearings (#20) for wear. To remove the roller bearings from the crankshaft, use a three inch push puller with a pulley attachment. To remount the bearings, tap the bearings down the well-lubricated crankshaft with the Giant Bearing Tool. Be sure that the bearing is firmly seated.
20. Remove the connecting rod (#24) with the attached crosshead/plunger assembly (#25) from the crankcase (#1) by pulling it straight out. The oil seals (#31) may now be removed by tapping them out through the front of the crankcase. Be careful not to damage the snap ring.
21. Inspect the surfaces of the crosshead/plunger assembly (#25) and connecting rods (#24) for heavy scoring or galling due to poor lubrication. Check for play at the joint between connecting rod crosshead/plunger assembly.
22. To remove the crosshead pin (#28) from the crosshead/plunger assembly (#25), the assembly should be positioned in such a manner to prevent damage to the crosshead when driving the pin out. The crosshead pin can be driven out by tapping on the tapered side of the pin

Reassembly sequence

Note: Always take time to lubricate all metal and nonmetal parts with a light film of oil before reassembly. This step will help ensure a proper fit, at the same time it will protect the pump nonmetal parts (elastomers) from cutting and scoring.

23. Take the crosshead/plunger rod assembly and insert the connecting rod (#24) into the crosshead/plunger assembly (#25). Drive the tapered end of the crosshead pin (#28) into the beveled side of the crosshead and through the connecting rod completing the assembly.

Note: The crosshead pin should not extend beyond either side of the crosshead in order to prevent damage to the crosshead bore of the crankcase.

24. Inspect the crankcase crosshead guides for any possible damage.
25. Replace the connecting rod (#24), crosshead/plunger rod assembly (#25) into the crankcase (#1).
26. If removed previously, replace the far side bearing race into the crankcase. Tap with a rubber mallet until the edges are flush with the crankcase surface.
27. Remove the old crankshaft seal (#15) from the bearing cover (#14). Lubricate the edges of the new seal and install using the standard Giant Bearing Tool. Remove the bearing tool and tap around the perimeter of the seal with a rubber mallet to firmly seat the seal. Position the far bearing cover on the crankcase (#1) and insert the cover bolts (#17). Tighten the cover evenly to the crankcase, setting the bearing into position. Torque the cover bolts to 125 inch-pounds.
28. Insert the crankshaft (#22) with the mounted bearings (#20) through the near side of the crankcase (#1). **Make certain that the numbers (or colors) or the crankshaft correspond to the numbers (or colors) on the connecting rods (#24).** Reinstall the near side bearing race by inserting it into the crankcase. Supporting the crankshaft with one hand, tap the race with a rubber mallet until the edge is flush with the crankcase.

NOTE: Contact Giant Industries for Service School Information. Phone: (419)-531-4600

29. Replace any shims (#20A) and position the bearing cover (#14) as before. Tighten the bearing cover bolts (#17) evenly to position the bearing race. Torque the bolts to 125 inch-pounds. Once the crankshaft reassembly is complete, oil the crankshaft races freely before replacing the connecting rod (#24) end caps.
30. Reassemble the connecting rods (#24), matching the numbered (or colored) halves. Torque the connecting rod bolts (#24A) to 250 inch-pounds.
31. To replace the oil seal (#31) apply locktite to the outside edges of the seal and install from the front of the crankcase (#1). The side of the seal with the spring must face the oil. Make sure that the face of the seal is flush with the crankcase.

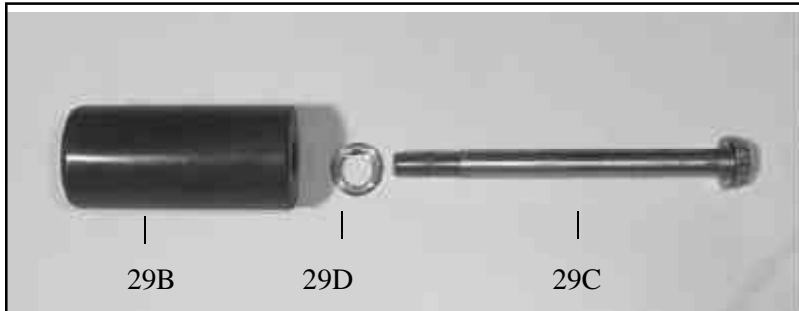

32. Inspect the ceramic plungers (#29B) and replace them if necessary. Clean the ends of the ceramic and remount onto the crosshead/plunger assembly. Make certain that the end of the plunger which is not counter-bored is facing the discharge side of the pump. Install the seal washer (#29D) on the bolt assembly.
33. Clean the bolt threads (#29C), apply locktite, and remount.

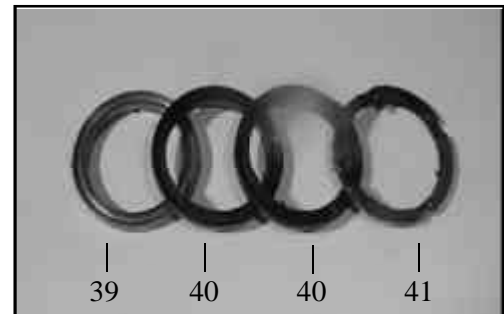
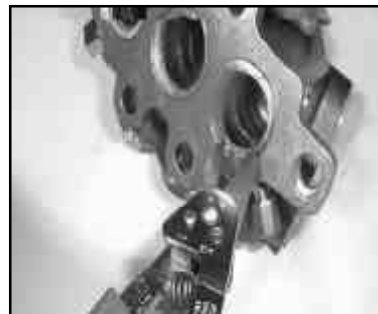

- 33a. Torque the ceramic plunger bolt assembly to 300 inch-pounds. If originally removed, reinstall the stud bolts (#49).
34. Install the rear support ring (#41), rear v-sleeve (#40), rear pressure ring (#39). Install the snap ring (#36).
35. Reinstall the pressure ring (#39), v-sleeves (#40) and support ring (#41) into each plunger bore. Reinstall the tension spring (#42).



36. Reassemble the discharge valve assembly by placing the valve plate (#45), spring (#46), and spring retainer (#47) on top of the valve seat (#44). Press fit together.



37. Place the entire discharge assembly into discharge port making certain the assembly is properly seated. Install discharge plug (#48) and hand tighten.



38. Reassemble the inlet valve assembly in the reverse order of step #7. Make certain all the components are press fit together and that the spring retainer (#54) is slightly counter sunk in the valve housing (#52). Grease the o-ring (#53) and install it on to the valve housing. Reinstall the entire inlet valve assembly into the manifold (#43). install the tension plugs (#42A) and tighten.



39. Again lubricate the plungers (29B) and slide the manifold (#43) gently and evenly over the plungers. Press the manifold firmly into place against the crankcase (#1). Install the spring washer (#50A) and tighten the manifold stud nuts (#50) to 58 ft.lbs.

MP4130HT(C) TORQUE SPECIFICATIONS

<u>Position</u>	<u>Item#</u>	<u>Description</u>	<u>Torque Amount</u>
10	01010	Screw, Crankcase Cover	125 ft-lbs.
17	07114	Hex Screw, Bearing Cover	125 in-lbs.
24A	07122	Hex Screw, Connecting Rod	250 in-lbs.
29C	07257	Bolt, Plunger	300 in-lbs.
50	07158	Nut, Manifold Stud	58 ft-lbs.

PUMP SYSTEM MALFUNCTION

<u>MALFUNCTION</u>	<u>CAUSE</u>	<u>REMEDY</u>
The Pressure and/or the Delivery Drops	Worn packing seals Broken valve spring Belt slippage Worn or Damaged nozzle Fouled discharge valve Fouled inlet strainer Worn or Damaged hose Worn or Plugged relief valve on pump Cavitation Unloader	Replace packing seals Replace spring Tighten or Replace belt Replace nozzle Clean valve assembly Clean strainer Repair/Replace hose Clean, Reset, and Replace worn parts Check suction lines on inlet of pump for restrictions Check for proper operation
Water in crankcase	High humidity Worn seals	Reduce oil change interval Replace seals
Noisy Operation	Worn bearings Cavitation	Replace bearings, Refill crankcase oil with recommended lubricant Check inlet lines for restrictions and/or proper sizing
Rough/Pulsating Operation with Pressure Drop	Worn packing Inlet restriction Accumulator pressure Unloader Cavitation	Replace packing Check system for stoppage, air leaks, correctly sized inlet plumbing to pump Recharge/Replace accumulator Check for proper operation Check inlet lines for restrictions and/or proper size
Pressure Drop at Gun	Restricted discharge plumbing	Re-size discharge plumbing to flow rate of pump
Excessive Leakage	Worn plungers Worn packing/seals Excessive vacuum Cracked plungers Inlet pressure too high	Replace plungers Adjust or Replace packing seals Reduce suction vacuum Replace plungers Reduce inlet pressure
High Crankcase Temperature	Wrong Grade of oil Improper amount of oil in crankcase	Giant oil is recommended Adjust oil level to proper amount

MP4130HT(C) DIMENSIONS (mm)

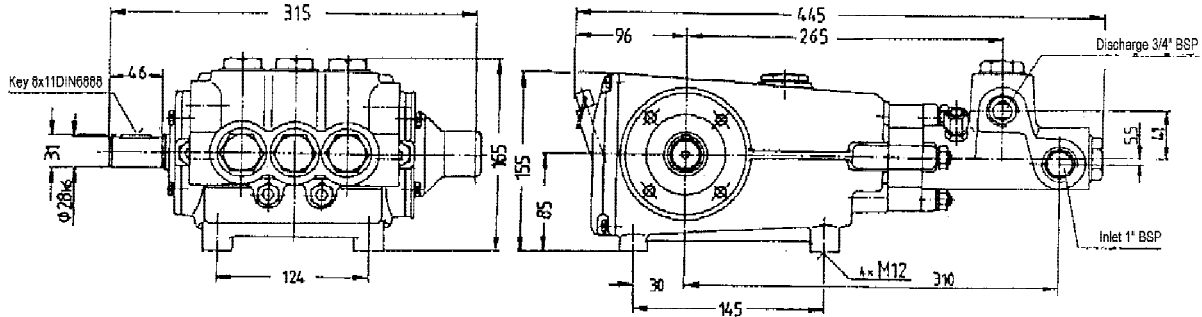

GIANT INDUSTRIES LIMITED WARRANTY

Giant Industries, Inc. pumps and accessories are warranted by the manufacturer to be free from defects in workmanship and material as follows:

1. For portable pressure washers and car wash applications, the discharge manifolds will never fail, period. If they ever fail, we will replace them free of charge. Our other pump parts, used in portable pressure washers and in car wash applications, are warranted for five years from the date of shipment for all pumps used in NON-SALINE, clean water applications.
2. One (1) year from the date of shipment for all other Giant industrial and consumer pumps.
3. Six (6) months from the date of shipment for all rebuilt pumps.
4. Ninety (90) days from the date of shipment for all Giant accessories.

This warranty is limited to repair or replacement of pumps and accessories of which the manufacturer's evaluation shows were defective at the time of shipment by the manufacturer. The following items are NOT covered or will void the warranty:

1. Defects caused by negligence or fault of the buyer or third party.
2. Normal wear and tear to standard wear parts.
3. Use of repair parts other than those manufactured or authorized by Giant.
4. Improper use of the product as a component part.
5. Changes or modifications made by the customer or third party.
6. The operation of pumps and or accessories exceeding the specifications set forth in the Operations Manuals provided by Giant Industries, Inc.

Liability under this warranty is on all non-wear parts and limited to the replacement or repair of those products returned freight prepaid to Giant Industries which are deemed to be defective due to workmanship or failure of material. A Returned Goods Authorization (R.G.A.) number and completed warranty evaluation form is required prior to the return to Giant Industries of all products under warranty consideration. Call (419)-531-4600 or fax (419)-531-6836 to obtain an R.G.A. number.

Repair or replacement of defective products as provided is the sole and exclusive remedy provided hereunder and the MANUFACTURER SHALL NOT BE LIABLE FOR FURTHER LOSS, DAMAGES, OR EXPENSES, INCLUDING INCIDENTAL AND CONSEQUENTIAL DAMAGES DIRECTLY OR INDIRECTLY ARISING FROM THE SALE OR USE OF THIS PRODUCT.

THE LIMITED WARRANTY SET FORTH HEREIN IS IN LIEU OF ALL OTHER WARRANTIES OR REPRESENTATION, EXPRESS OR IMPLIED, INCLUDING WITHOUT LIMITATION ANY WARRANTIES OR MERCHANTABILITY OR FITNESS FOR A PARTICULAR PURPOSE AND ALL SUCH WARRANTIES ARE HEREBY DISCLAIMED AND EXCLUDED BY THE MANUFACTURER.



GIANT INDUSTRIES, INC., 900 N. Westwood Ave., P.O. Box 3187, Toledo, Ohio 43607
PHONE (419) 531-4600, FAX (419) 531-6836, www.giantpumps.com
© Copyright 2001 Giant Industries, Inc.

Free Manuals Download Website

<http://myh66.com>

<http://usermanuals.us>

<http://www.somanuals.com>

<http://www.4manuals.cc>

<http://www.manual-lib.com>

<http://www.404manual.com>

<http://www.luxmanual.com>

<http://aubethermostatmanual.com>

Golf course search by state

<http://golfingnear.com>

Email search by domain

<http://emailbydomain.com>

Auto manuals search

<http://auto.somanuals.com>

TV manuals search

<http://tv.somanuals.com>