

# Series CP200

Triplex Ceramic  
Plunger Pump  
Operating Instructions/  
Repair and Service  
Manual

For Models:  
CP218  
CP220  
CP230



**GIANT**

## Contents:

Installation Instructions:	page 2
Pump Specifications:	pages 3-5
Exploded View:	page 6
Parts List:	page 7
Recommended Spare Kits & Torque Specifications:	page 8
Pump Mounting Selection Guide:	page 8
Repair Instructions:	pages 9-10
Trouble Shooting:	page 11
Preventative Maintenance:	page 11
Dimensions:	back page
Warranty Information:	back page

# INSTALLATION INSTRUCTIONS

**Installation of the Giant Industries, Inc., pump is not a complicated procedure, but there are some basic steps common to all pumps. The following information is to be considered as a general outline for installation. If you have unique requirements, please contact Giant Industries, Inc. or your local distributor for assistance.**

1. The pump should be installed flat on a base to a maximum of a 15 degree angle of inclination to ensure optimum lubrication.
2. The inlet to the pump should be sized for the flow rate of the pump with no unnecessary restrictions that can cause cavitation. Teflon tape should be used to seal all joints. If pumps are to be operated at temperatures in excess of 160° F, it is important to insure a positive head to the pump to prevent cavitation.
3. The discharge plumbing from the pump should be properly sized to the flow rate to prevent line pressure loss to the work area. It is essential to provide a safety bypass valve between the pump and the work area to protect the pump from pressure spikes in the event of a blockage or the use of a shut-off gun.

4. Use of a dampener is necessary to minimize pulsation at drive elements, plumbing, connections, and other system areas. The use of a dampener with Giant Industries, Inc. pumps is optional, although recommended by Giant Industries, Inc. to further reduce system pulsation. Dampeners can also reduce the severity of pressure spikes that occur in systems using a shut-off gun. A dampener must be positioned downstream from the unloader.

5. Crankshaft rotation on Giant Industries, Inc. pumps should be made in the direction designated by the arrows on the pump crankcase. Reverse rotation may be safely achieved by following a few guidelines available upon request from Giant Industries, Inc. Required horsepower for system operation can be obtained from the charts on pages 3-6.

6. Before beginning operation of your pumping system, remember: Check that the crankcase and seal areas have been properly lubricated per recommended schedules. Do not run the pump dry for extended periods of time. Cavitation will result in severe damage. Always remember to check that all plumbing valves are open and that pumped media can flow freely to the inlet of the pump.

Finally, remember that high pressure operation in a pump system has many advantages. But, if it is used carelessly and without regard to its potential hazard, it can cause serious injury.

## IMPORTANT OPERATING CONDITIONS

**Failure to comply with any of these conditions invalidates the warranty.**

1. Prior to initial operation, add oil to the crankcase so that oil level is between the two lines on the oil dipstick. **DO NOT OVERFILL.**

**Use Giant Oil or Use SAE 0 W 40 when pumping CO<sub>2</sub> under 32°F (0° C)**

Crankcase oil should be changed after the first 50 hours of operation, then at regular intervals of 500 hours or less depending on operating conditions.

2. Pump operation must not exceed rated pressure, volume, or RPM. A pressure relief device must be installed in the discharge of the system.

3. Acids, alkalines, or abrasive fluids cannot be pumped unless approval in writing is obtained before operation from Giant Industries, Inc.

4. Run the pump dry approximately 10 seconds to drain the water before exposure to freezing temperatures.

# Specifications

## Model CP218

Ratings .....	1.4 GPM @ 2030 PSI
Inlet Pressure .....	14 to 140 PSI
RPM .....	Up to 750 RPM
Plunger Diameter .....	18mm
Stroke .....	10mm
Temperature of Pumped Fluids .....	-40°F to 160°F
Inlet Ports .....	(2) 3/8" BSP
Discharge Ports .....	(2) 3/8" BSP
Shaft Rotation .....	Top of Pulley Towards Fluid End
Crankshaft Diameter .....	24mm
Key Width .....	8mm
Shaft Mounting .....	Right Side Facing Manifold
Weight .....	11 lbs. 11oz.
Crankcase Oil Capacity .....	7.5 fl.oz.
Extended Crankcase Oil Capacity .....	9.0 fl.oz.

\*Positive inlet pressure required

Consult the factory for special requirements that must be met if the pump is to operate beyond one or more of the limits specified above.

**NOTE:**

In order to drive the pump from the side opposite the present shaft extension, simply remove the valve casing from the crankcase and rotate the pumps 180 degrees to the desired position. Be certain to rotate the seal case (item #20) as well, so that the weep holes are down at the six o'clock position. Exchange the oil fill and the oil drain plugs, also. Refer to the repair instructions as necessary for the proper assembly sequence.

<b>CP218 HORSEPOWER REQUIREMENTS</b>					
RPM	GPM	500 PSI	1000 PSI	1500 PSI	2030 PSI
200	0.4	0.1	0.3	0.4	0.6
300	0.6	0.2	0.4	0.6	0.8
400	0.7	0.2	0.5	0.7	1.0
500	0.9	0.3	0.6	0.9	1.3
600	1.1	0.4	0.8	1.1	1.5
750	1.4	0.5	1.0	1.4	2.0

**HORSEPOWER RATINGS:**

The rating shown are the power requirements for the pump. Gas engine power outputs must be approximately twice the pump power requirements shown above.

We recommend a 1.15 service factor be specified when selecting an electric motor as the power source. To compute specific pump horse power requirements, use the following formula:

$$HP = (GPM \times PSI) / 1450$$

# Specifications Model CP220

Ratings .....	1.9 GPM @ 2030 PSI
Inlet Pressure .....	14 to 140 PSI
RPM .....	Up to 750 RPM
Plunger Diameter .....	18mm
Stroke .....	-40° to 160°F
Inlet Ports .....	(2) 3/8" BSP
Discharge Ports .....	(2) 3/8" BSP
Shaft Rotation .....	Top of Pulley Towards Fluid End
Crankshaft Diameter .....	24mm
Key Width .....	8mm
Shaft Mounting .....	Right Side Facing Manifold
Weight .....	11 lbs. 11 oz.
Crankcase Oil Capacity .....	7.5 fl.oz.
Extended Crankcase Oil Capacity .....	9.0 fl.oz.

Consult the factory for special requirements that must be met if the pump is to operate beyond one or more of the limits specified above.

**NOTE:**

In order to drive the pump from the side opposite the present shaft extension, simply remove the valve casing from the crankcase and rotate the pumps 180 degrees to the desired position. Be certain to rotate the seal case (item #20) as well, so that the weep holes are down at the six o'clock position. Exchange the oil fill and the oil drain plugs, also. Refer to the repair instructions as necessary for the proper assembly sequence.

<b>CP220 HORSEPOWER REQUIREMENTS</b>					
RPM	GPM	500 PSI	1000 PSI	1500 PSI	2030 PSI
200	0.5	0.2	0.3	0.5	0.7
300	0.8	0.3	0.6	0.8	1.1
400	1.0	0.3	0.7	1.0	1.4
500	1.3	0.4	0.9	1.3	1.8
600	1.5	0.5	1.0	1.6	2.1
750	1.9	0.7	1.3	2.0	2.7

**HORSEPOWER RATINGS:**

The rating shown are the power requirements for the pump. Gas engine power outputs must be approximately twice the pump power requirements shown above.

We recommend a 1.15 service factor be specified when selecting an electric motor as the power source. To compute specific pump horse power requirements, use the following formula:

$$HP = (GPM \times PSI) / 1450$$

# Specifications

## Model CP230

Ratings .....	0.5 GPM @ 2030 PSI
Inlet Pressure .....	14 to 140 PSI
RPM .....	Up to 750 RPM
Plunger Diameter .....	18mm
Stroke .....	3.4mm
Temperature of Pumped Fluids .....	-40° to 160°F
Inlet Ports .....	(2) 3/8" BSP
Discharge Ports .....	(2) 3/8" BSP
Shaft Rotation .....	Top of Pulley Towards Fluid End
Crankshaft Diameter .....	24mm
Key Width .....	8mm
Shaft Mounting .....	Right Side Facing Manifold
Weight .....	11 lbs. 11oz.
Crankcase Oil Capacity .....	7.5 fl.oz.
Extended Crankcase Oil Capacity .....	9.0 fl.oz.

\*Positive inlet pressure required

Consult the factory for special requirements that must be met if the pump is to operate beyond one or more of the limits specified above.

**NOTE:**

In order to drive the pump from the side opposite the present shaft extension, simply remove the valve casing from the crankcase and rotate the pumps 180 degrees to the desired position. Be certain to rotate the seal case (item #20) as well, so that the weep holes are down at the six o'clock position. Exchange the oil fill and the oil drain plugs, also. Refer to the repair instructions as necessary for the proper assembly sequence.

<b>CP230 HORSEPOWER REQUIREMENTS</b>					
RPM	GPM	500 PSI	1000 PSI	1500 PSI	2030 PSI
200	0.1	0.0	0.1	0.1	0.1
300	0.2	0.1	0.1	0.2	0.3
400	0.3	0.1	0.2	0.3	0.4
500	0.3	0.1	0.2	0.3	0.4
600	0.4	0.1	0.3	0.4	0.6
750	0.5	0.2	0.3	0.5	0.7

**HORSEPOWER RATINGS:**

The rating shown are the power requirements for the pump. Gas engine power outputs must be approximately twice the pump power requirements shown above.

We recommend a 1.15 service factor be specified when selecting an electric motor as the power source. To compute specific pump horse power requirements, use the following formula:

$$HP = (GPM \times PSI) / 1450$$

# Exploded View CP200 Series

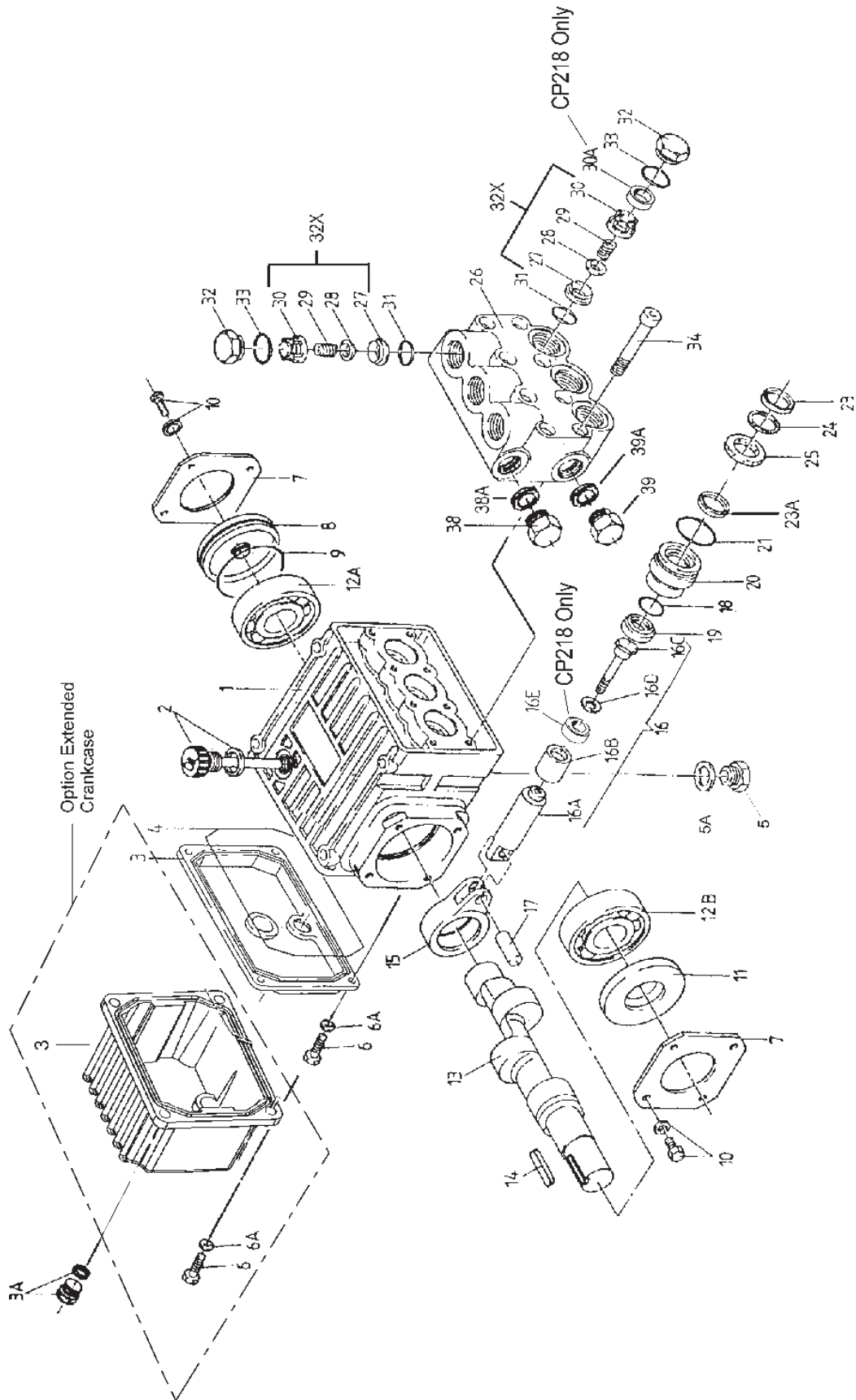

## Spare Parts CP200 Series

<u>ITEM</u>	<u>PART NO.</u>	<u>DESCRIPTION</u>	<u>QTY.</u>	<u>ITEM</u>	<u>PART NO.</u>	<u>DESCRIPTION</u>	<u>QTY.</u>
1	08300	Crankcase	1	16C	08456	Tension Screw	3
2	06773	Oil Dipstick with O-Ring	1	16D	07676	Copper Gasket	3
3	08302	Crankcase Cover, Short	1	16D	07204-0100	Copper Gasket <b>(CP230 only)</b>	3
3	08302-L	Crankcase Cover, Long	1	16E	06823	Plunger Extension <b>(CP230 only)</b>	3
3A	07190	Drain Plug & Gasket	1	17	08442	Wrist Pin	3
4	08005	O-Ring	1	18	07770	O-Ring	3
5	06273	Oil Drain Plug	1	19	08356-0010	Oil Seal	3
5A	08192	Gasket	1	20	08444	Seal Case	3
6	07188	Screw, Crankcase Cover	4	21	06815	O-Ring	3
6A	07223-0100	Spring Washer	4	23	08087	V-Sleeve, Weep	3
7	08303	Bearing Cover I	2	23A	08087-0020	V-Sleeve, Teflon	3
8	08490	Oil Sight Glass	1	24	07904	Pressure Ring	3
9	08492	O-Ring	1	25	08445	Weep Return Ring	3
10	07225	Screw with Lock Washer	8	26	08446	Valve Casing	1
11	01166	Radial Shaft Seal	1	27	07849	Valve Seat	6
12A	08020	Ball Bearing	1	28	06809	Valve Plate	6
12B	01020	Ball Bearing	1	29	06816	Valve Spring	6
13	08440	Crankshaft <b>(CP218)</b>	1	30	07907	Valve Spring Retainer	6
13	08467	Crankshaft <b>(CP220)</b>	1	30A	06824	Spacer Ring <b>(CP230 only)</b>	3
13	06694	Crankshaft <b>(CP230)</b>	1	31	06817	O-Ring	6
14	06207	Woodruff Key	1	32	07928	Valve Plug	6
15	08333	Connecting Rod	3	32X	06825	Valve Assembly	6
16	08469	Plunger, Complete, 18mm	3	33	06818	O-Ring	6
16A	08468	Plunger Base	3	34	08316	Hex Head Cap Screw	8
16B	08455	Plunger Pipe	3	38	13338	Plug, 3/8" BSP	1

# Repair Kits CP200 Series

## Plunger Packing Kit

Part # 09554

<u>Item #</u>	<u>Part #</u>	<u>Description</u>	<u>Qty.</u>
23	08087	V-Sleeve, weep	3
23A	08087-0020	V-Sleeve, brown	3
24	07904	Pressure Ring	3

## Oil Seal Kit

Part # 09144

<u>Item #</u>	<u>Part #</u>	<u>Description</u>	<u>Qty.</u>
19	08356-0010	Oil Seal	3

## Valve Assembly Kit

Part # 09556

<u>Item #</u>	<u>Part #</u>	<u>Description</u>	<u>Qty.</u>
27	07849	Valve Seat	6
28	06809	Valve Plate	6
29	06816	Valve Spring	6
30	07907	Valve Spring Retainer	6
31	06817	O-Ring	6

# Pump Torque Specifications CP200 Series

<u>Position</u>	<u>Item#</u>	<u>Description</u>	<u>Torque Amount</u>
16C	08456	Tension Screw, Plunger	220 (in.-lbs.)
32	07928	Valve Plug	59 (ft.-lbs.)
34	08316	Hex Head Cap Screw, Valve Casing	105 (in.-lbs.)

## Pump Mounting Selection Guide

<p><b>Bushings</b> 01074 - 24 mm Tapered H Bushing</p>
<p><b>Pulley &amp; Sheaves</b> 01061 - 7.75" Cast Iron 1 gr. - AB Section 01062 - 7.75" Cast Iron - 2 gr. - AB Section</p>
<p><b>Rails</b> 01160 - Plated Steel Channel Rails (L=5.75"xW=1.00"xh=2.50") 01161 - Plated Steel Channel Rails (L=5.75"xW=1.00"xH=2.50")</p>



## REPAIR INSTRUCTIONS - CP200 PUMPS

**NOTE: Always take time to lubricate all metal and nonmetal parts with a light film of oil before reassembly. This step will ensure proper fit, at the same time protecting the pump nonmetal parts (i.e., the elastomers) from cutting and scoring.**



1. With a 22mm socket wrench, remove the (3) discharge valve plugs and (3) inlet valve plugs (32). Inspect the o-ring (33) for wear and replace if damaged.

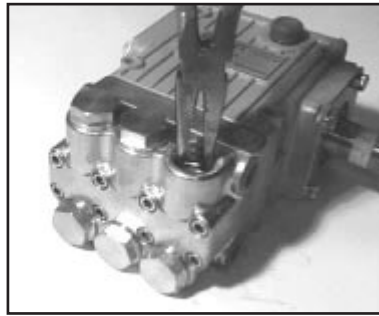

2. Using a needle nose pliers, remove the inlet and discharge valve assemblies (27-31).



3. By inserting a small screw driver between the valve seat (27) and the valve spring retainer (30), the valve assembly can be separated.



4. Remove the o-ring (31). Inspect all parts for wear and replace as necessary. For pumps manufactured prior to 5/97, tighten plugs (32) to 33 ft.-lbs. otherwise, apply one drop of Loctite 243 to the valve plugs (32) and tighten to 59 ft.-lbs.

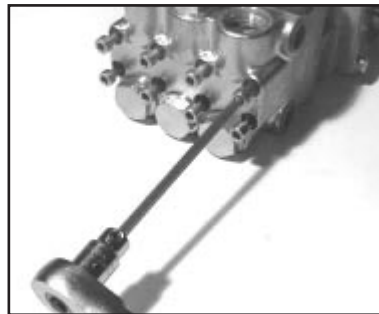

5. Next, use a 5mm allen wrench to remove the 8 socket head cap screws (34).

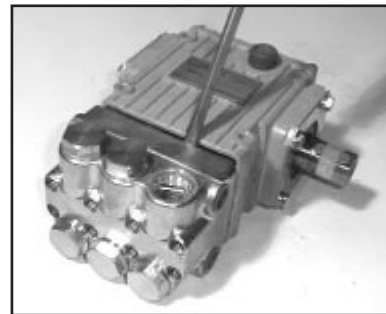

6. Carefully slide the valve casing (26) out over the plungers.



7. Remove the weep return ring (25), pressure ring (24), and v-sleeve (23) from the valve casing (26). The spacer ring (30A) on CP230 pumps may remain inside the valve casing.

Remove the v-sleeve (23A) from the seal case (20). Inspect all parts, including o-ring (21) for wear and replace as necessary

8. Check surfaces of plunger (16). A damaged surface will cause accelerated wear on the seals. Deposits of any kind must be carefully removed from the plunger surface. A damaged plunger must be replaced!



9. If the crankcase oil seals (19) are to be replaced, they can be removed by prying loose with a flat screwdriver. Take care not to make contact with the plunger.

## REPAIR INSTRUCTIONS - CP200

10. If the ceramic plunger pipe (16B) is damaged, remove the plunger bolt (16C) and plunger extension (16E-CP230 only). Discard the old plunger pipe (16B) and copper gasket (16D). Clean the old locktite from the plunger bolt (16C) and plunger base (16A). Replace the plunger pipe, plunger extension (16E-CP230 only) and locktite the plunger bolt and torque to 220 inch-pounds. **Make sure you use a new gasket (16D) with the plunger bolt.**

***NOTE: If there are deposits of any kind (i.e., lime deposits) in the valve casing, be certain that the weep holes in the weep return ring (25) and valve casing (26) have not been plugged.***

### Reassembly sequence of the CP200 pumps

- 1) If oil seals (19) were removed, replace with seal lip towards crankcase. Lubricate seals before replacing.
- 2) Replace seal case (20) with o-rings (21) over plungers. Generously lubricate o-rings and oil seal before reassembly. Replace v-sleeve (23A) over plungers (16)..
- 3) Generously lubricate v-sleeve (23). Assemble v-sleeves (22) into valve casing (#26). Make sure spacer ring (30E - CP230 pumps only) is present in the valve casing. Assemble weep return ring (25) and pressure ring (24) over plungers (16). Slide valve casing over plungers and seat firmly. Replace the eight socket head cap screws (34) and tighten to 105 inch-pounds in a crossing pattern.
- 4) Replace the six o-rings (31) and the six valve assemblies (32X). Now replace the six valve plug o-rings (33). Apply one drop of Loctite 243 to the valve plugs (32) and tighten to 59 ft.-lbs.

**NOTE: Contact Giant Industries for Service School Information. Phone: (419)-531-4600**

# PUMP SYSTEM MALFUNCTION

<u>MALFUNCTION</u>	<u>CAUSE</u>	<u>REMEDY</u>
The Pressure and/or the Delivery Drops	Worn packing seals Broken valve spring Belt slippage Worn or Damaged nozzle Fouled discharge valve Fouled inlet strainer Worn or Damaged hose Worn or Plugged relief valve on pump Cavitation pump for restrictions Unloader	Replace packing seals Replace spring Tighten or Replace belt Replace nozzle Clean valve assembly Clean strainer Repair/Replace hose Clean, Reset, and Replace worn parts Check suction lines on inlet of  Check for proper operation
Water in crankcase	High humidity Worn seals	Reduce oil change interval Replace seals
Noisy Operation	Worn bearings oil with Cavitation	Replace bearings, Refill crankcase recommended lubricant Check inlet lines for restrictions and/or proper sizing
Rough/Pulsating Operation with Pressure Drop	Worn packing Inlet restriction  Accumulator pressure Unloader Cavitation	Replace packing Check system for stoppage, air leaks, correctly sized inlet plumbing to pump Recharge/Replace accumulator Check for proper operation Check inlet lines for restrictions and/or proper size
Pump Pressure as gun Pressure	Restricted discharge plumbing	Re-size discharge plumbing to Drop at flow rate of pump Rated,
Excessive Leakage	Worn plungers Worn packing/seals Excessive vacuum Cracked plungers Inlet pressure too high	Replace plungers Adjust or Replace packing seals Reduce suction vacuum Replace plungers Reduce inlet pressure
High Crankcase Temperature	Wrong Grade of oil Improper amount of oil in crankcase	Giant oil is recommended Adjust oil level to proper amount

## Preventative Maintenance Check-List & Recommended Spare Parts List

Check	Daily	Weekly	50hrs	Every 500 hrs	Every 1500 hrs	Every 3000 hrs
Oil Level/Quality	X					
Oil Leaks	X					
Water Leaks	X					
Belts, Pulley		X				
Plumbing		X				
<b>Recommended Spare Parts</b>						
Oil Change (1 Quart) p/n 1153			X	X		
Seal Spare Parts (1 kit/pump) (See page 8 for kit list)					X	
Oil Seal Kit (1 kit/pump) (See page 8 for kit list)					X	
Valve Spare Parts (1 kit/pump) (See page 8 for kit list)						X

## CP200 SERIES DIMENSIONS (inches)

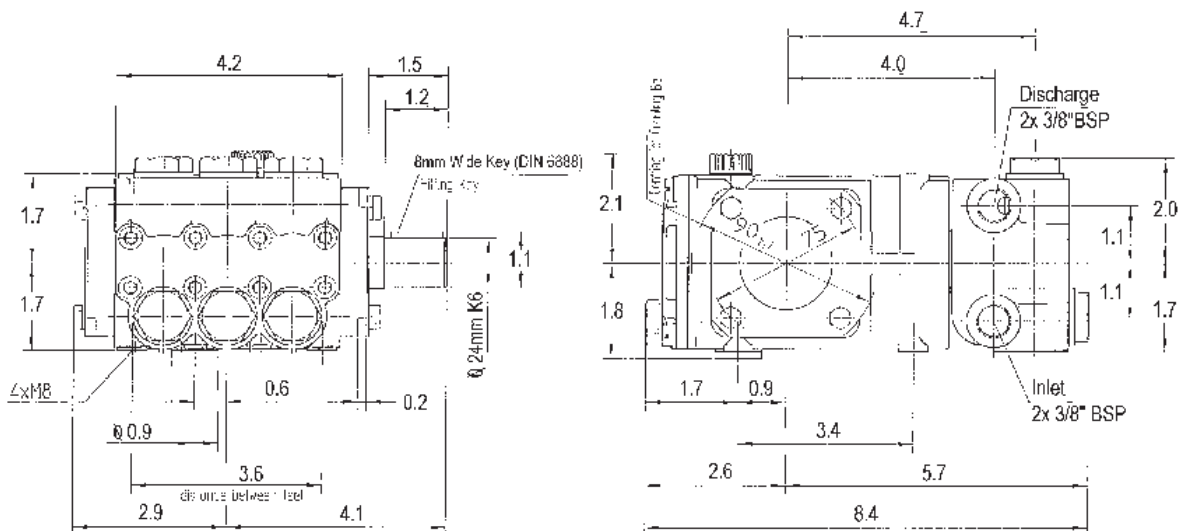

### GIANT INDUSTRIES LIMITED WARRANTY

Giant Industries, Inc. pumps and accessories are warranted by the manufacturer to be free from defects in workmanship and material as follows:

1. For portable pressure washers and self-serve car wash applications, the discharge manifolds will never fail, period. If they ever fail, we will replace them free of charge. Our other pump parts, used in portable pressure washers and in car wash applications, are warranted for five years from the date of shipment for all pumps used in NON-SALINE, clean water applications.
2. One (1) year from the date of shipment for all other Giant industrial and consumer pumps.
3. Six (6) months from the date of shipment for all rebuilt pumps.
4. Ninety (90) days from the date of shipment for all Giant accessories.

This warranty is limited to repair or replacement of pumps and accessories of which the manufacturer's evaluation shows were defective at the time of shipment by the manufacturer. The following items are NOT covered or will void the warranty:

1. Defects caused by negligence or fault of the buyer or third party.
2. Normal wear and tear to standard wear parts.
3. Use of repair parts other than those manufactured or authorized by Giant.
4. Improper use of the product as a component part.
5. Changes or modifications made by the customer or third party.
6. The operation of pumps and or accessories exceeding the specifications set forth in the Operations Manuals provided by Giant Industries, Inc.

Liability under this warranty is on all non-wear parts and limited to the replacement or repair of those products returned freight prepaid to Giant Industries which are deemed to be defective due to workmanship or failure of material. A Returned Goods Authorization (R.G.A.) number and completed warranty evaluation form is required prior to the return to Giant Industries of all products under warranty consideration. Call (419)-531-4600 or fax (419)-531-6836 to obtain an R.G.A. number.

Repair or replacement of defective products as provided is the sole and exclusive remedy provided hereunder and the MANUFACTURER SHALL NOT BE LIABLE FOR FURTHER LOSS, DAMAGES, OR EXPENSES, INCLUDING INCIDENTAL AND CONSEQUENTIAL DAMAGES DIRECTLY OR INDIRECTLY ARISING FROM THE SALE OR USE OF THIS PRODUCT.

THE LIMITED WARRANTY SET FORTH HEREIN IS IN LIEU OF ALL OTHER WARRANTIES OR REPRESENTATION, EXPRESS OR IMPLIED, INCLUDING WITHOUT LIMITATION ANY WARRANTIES OR MERCHANTABILITY OR FITNESS FOR A PARTICULAR PURPOSE AND ALL SUCH WARRANTIES ARE HEREBY DISCLAIMED AND EXCLUDED BY THE MANUFACTURER.



GIANT INDUSTRIES, INC., 900 N. Westwood Ave., P.O. Box 3187, Toledo, Ohio 43607  
PHONE (419) 531-4600, FAX (419) 531-6836, www.giantpumps.com  
© Copyright 2002 Giant Industries, Inc.

4/02CP200.PM6

## Free Manuals Download Website

<http://myh66.com>

<http://usermanuals.us>

<http://www.somanuals.com>

<http://www.4manuals.cc>

<http://www.manual-lib.com>

<http://www.404manual.com>

<http://www.luxmanual.com>

<http://aubethermostatmanual.com>

Golf course search by state

<http://golfingnear.com>

Email search by domain

<http://emailbydomain.com>

Auto manuals search

<http://auto.somanuals.com>

TV manuals search

<http://tv.somanuals.com>