



Air Conditioning & Heating

## PRODUCT SPECIFICATIONS



**50 Hz, 10-Ton**

**NOMINAL COOLING CAPACITY:  
120,000 BTU/H [35.2 kW]**



# CE COMMERCIAL SPLIT SYSTEM AIR CONDITIONER

The CE Commercial 10-ton split system air conditioner features the unique Goodman® sound control top design for quiet operation and is designed for ground-level or rooftop mount application.

### Standard Features

- Single-scroll compressor with crankcase heater
- Quiet operating top discharge
- Permanently lubricated condenser motor
- Copper tube/aluminum fin coil
- Brass suction ball valve and liquid front-seating shut-off valve with sweat connections
- Large-capacity liquid line filter dryer
- High- and low-pressure switches
- Contactor with lug connections
- Ground lug connection
- ETL Listed

### Cabinet Features

- Unique Goodman® sound control top design
- Steel louver coil guard protects the coil from damage and adds strength to unit
- Bottom pan rails elevate unit above slab
- Heavy-gauge galvanized-steel cabinet
- Attractive Architectural Gray powder-paint finish with 500-hour salt-spray approval
- When properly anchored, meets the 2001 Florida Building Code unit integrity requirements for hurricane-type winds

# NOMENCLATURE

	<b>C</b>	<b>E</b>	<b>120</b>	<b>3</b>	<b>AA</b>
	<b>1</b>	<b>2</b>	<b>3,4,5</b>	<b>6</b>	<b>7,8</b>
<b>Product Category</b>	C Split System				Engineering Major/ Minor Revisions
<b>Unit Type</b>	E Commercial Air Conditioner				Electrical
	K Air Conditioner			1 208/230 V, 1 Phase, 60 Hz	
	P Heat Pump			2 220/240 V, 1 Phase, 50 Hz	
<b>Nominal Capacity</b>				3 208/230 V, 3 Phase, 60 Hz	
018 1½ Tons	048 4 Tons			4 460 V, 3 Phase, 60 Hz	
024 2 Tons	060 5 Tons			5 380/415 V, 3 Phase, 50 Hz	
030 2½ Tons	090 7½ tons				
036 3 Tons	120 10 Tons				
042 3½ Tons					

## SPECIFICATIONS

Capacities	CE120-5
Nominal Cooling (BTU/h)	114,000
EER <sup>1</sup>	9.0
Decibels	84
Compressor	
RLA / LRA	17.2 / 118
Volts	380-420
Condenser Fan Motor	
Horsepower / FLA	1 / 2
Volts	380
Refrigeration System	
Liquid Valve Size ("O.D.)	5/8"
Suction Valve Size ("O.D.)	1 1/8"
Valve Type	Sweat
Refrigerant Charge	32

Condenser Fan / Coil	CE120-5
Horsepower - RPM	1-930
Fan Diameter/ # Fan Blades	26/3
Outdoor Nominal CFM	4,400
Face Area (ft <sup>2</sup> )	29.4
Rows Deep/ Fins per Inch	1/22
Fin Type	Ripple
Coil No. of Tubes	40
Coil Tube Diameter	3/8"
Electrical Data	
Voltage-Hz / Phase	380/415-50/3
Min. Circuit Ampacity <sup>2</sup>	23.6
Max. Overcurrent Protection <sup>3</sup>	40 amps
Min / Max Volts	342/456
Power Supply Conduit Size	1/2" or 3/4"
Ship Weight (lbs-[kg])	296 [134]

<sup>1</sup> Energy Efficiency Ratio

<sup>2</sup> Wire size should be determined in accordance with National Electrical Codes. Extensive wire runs will require larger wire sizes.

<sup>3</sup> May use fuses or HACR-type circuit breakers of the same size as noted.

**Note:** Always check the S&R plate for electrical data on the unit being installed.

## PERFORMANCE RATINGS

Outdoor Unit	Indoor Unit	Cooling Capacity				dBs
		Total BTU/h	Sensible BTU/h	EER <sup>1</sup>	kWI <sup>2</sup>	
CE120-5	AR-120-2	114,000	83,000	9.0	12.67	84
	(2) CA*F4860*6*	114,000	83,000	9.0	12.67	

<sup>1</sup> Energy Efficiency Ratio

<sup>2</sup> kWI = Compressor + Indoor Blower + Outdoor Fan Watts

# EXPANDED PERFORMANCE RATINGS — CE120-5 / AR120-00-5

IDB	Airflow	Outdoor Ambient Temperature																								
		65				75				85				95												
		59	63	67	71	59	63	67	71	59	63	67	71	59	63	67	71									
70	4388	MBh	111.7	115.8	126.9	-	109.1	113.1	123.9	-	106.5	110.4	121.0	-	103.9	107.7	118.0	-	98.7	102.3	112.1	-	91.4	94.8	103.8	-
		S/T	0.73	0.61	0.42	-	0.76	0.63	0.44	-	0.78	0.65	0.45	-	0.80	0.67	0.46	-	0.83	0.70	0.48	-	0.84	0.70	0.49	-
		Δ T	17	15	11	-	17	15	11	-	17	15	11	-	17	15	11	-	17	15	11	-	16	14	11	-
		kW	9.84	10.05	10.36	-	10.59	10.82	11.16	-	11.25	11.50	11.87	-	11.84	12.10	12.49	-	12.33	12.61	13.02	-	12.76	13.05	13.48	-
		Amps	15.6	16.0	16.4	-	16.7	17.0	17.5	-	17.9	18.3	18.8	-	18.9	19.3	19.9	-	20.0	20.4	21.0	-	21.0	21.5	22.1	-
	3900	HI PR	138	148	157	-	155	166	176	-	176	189	200	-	200	216	228	-	225	243	256	-	249	268	283	-
		LO PR	59	63	69	-	62	66	73	-	65	69	75	-	68	73	79	-	71	76	83	-	74	79	86	-
		MBh	108.5	112.4	123.2	-	105.9	109.8	120.3	-	103.4	107.2	117.4	-	100.9	104.6	114.6	-	95.8	99.3	108.8	-	88.8	92.0	100.8	-
		S/T	0.70	0.58	0.40	-	0.72	0.60	0.42	-	0.74	0.62	0.43	-	0.77	0.64	0.44	-	0.79	0.66	0.46	-	0.80	0.67	0.46	-
		Δ T	18	15	12	-	18	16	12	-	18	16	12	-	18	16	12	-	18	16	12	-	17	15	11	-
3413	kW	9.54	9.73	10.04	-	10.26	10.47	10.80	-	10.89	11.13	11.48	-	11.45	11.70	12.08	-	11.93	12.19	12.59	-	12.34	12.61	13.03	-	
	Amps	15.2	15.5	15.9	-	16.2	16.5	17.0	-	17.3	17.7	18.2	-	18.3	18.7	19.3	-	19.3	19.8	20.3	-	20.3	20.8	21.4	-	
	HI PR	132	142	150	-	149	160	169	-	169	182	192	-	192	207	219	-	216	233	246	-	239	257	272	-	
	LO PR	57	60	66	-	60	64	70	-	62	66	72	-	65	70	76	-	69	73	80	-	71	76	82	-	
	MBh	100.1	103.8	113.7	-	97.8	101.3	111.0	-	95.4	98.9	108.4	-	93.1	96.5	105.7	-	88.5	91.7	100.5	-	81.9	84.9	93.1	-	

75	4388	MBh	113.6	117.0	126.6	135.9	111.0	114.2	123.7	132.7	108.3	111.5	120.7	129.6	105.7	108.8	117.8	126.4	100.4	103.4	111.9	120.1	93.0	95.7	103.6	111.2
		S/T	0.83	0.74	0.56	0.36	0.86	0.77	0.58	0.38	0.88	0.79	0.60	0.38	0.91	0.82	0.62	0.40	0.95	0.85	0.64	0.41	0.95	0.85	0.65	0.42
		Δ T	20	18	15	10	20	18	15	10	20	18	15	10	20	19	15	11	20	18	15	10	19	17	14	10
		kW	9.92	10.13	10.45	10.78	10.68	10.91	11.26	11.62	11.35	11.59	11.97	12.36	11.94	12.20	12.60	13.02	12.44	12.72	13.13	13.58	12.87	13.16	13.60	14.06
		Amps	15.8	16.1	16.5	17.0	16.8	17.2	17.6	18.2	18.0	18.4	18.9	19.5	19.1	19.5	20.0	20.7	20.1	20.6	21.2	21.9	21.2	21.6	22.3	23.0
	3900	HI PR	139	150	158	165	156	168	178	185	178	191	202	211	202	218	230	240	228	245	259	270	252	271	286	298
		LO PR	60	64	69	74	63	67	73	78	66	70	76	81	69	73	80	85	72	77	84	89	75	79	87	92
		MBh	110.3	113.6	122.9	131.9	107.7	110.9	120.1	128.9	105.2	108.3	117.2	125.8	102.6	105.6	114.3	122.7	97.5	100.4	108.6	116.6	90.3	93.0	100.6	108.0
		S/T	0.79	0.71	0.54	0.35	0.82	0.73	0.56	0.36	0.84	0.75	0.57	0.37	0.87	0.78	0.59	0.38	0.90	0.81	0.61	0.39	0.91	0.81	0.81	0.62
		Δ T	21	19	16	11	21	19	16	11	21	19	16	11	21	19	16	11	21	19	16	11	19	18	15	10
3413	kW	9.84	10.05	10.36	10.69	10.59	10.82	11.16	11.53	11.26	11.50	11.87	12.26	11.84	12.10	12.50	12.91	12.34	12.61	13.03	13.46	12.77	13.05	13.48	13.94	
	Amps	15.6	16.0	16.4	16.9	16.7	17.0	17.5	18.0	17.9	18.3	18.8	19.4	18.9	19.3	19.9	20.5	20.0	20.4	21.0	21.7	21.0	21.5	22.1	22.8	
	HI PR	138	148	157	163	155	166	176	183	176	189	200	209	200	216	228	237	225	243	256	267	249	268	283	295	
	LO PR	59	63	69	73	62	66	73	77	65	69	75	80	68	73	79	84	71	76	83	88	74	79	86	91	
	MBh	101.8	104.8	113.5	121.8	99.4	102.4	110.8	118.9	97.1	99.9	108.2	116.1	94.7	97.5	105.5	113.3	90.0	92.6	100.3	107.6	83.3	85.8	92.9	99.7	

IDB = Entering Indoor Dry Bulb Temperature

Shaded area is ACCA (TVA) conditions

EXPANDED PERFORMANCE RATINGS— CE120-5 / AR120-00-5 (CONT.)

IDB	Outdoor Ambient Temperature																																			
	65						75						85						95						105						115					
	59	63	67	71	75	79	59	63	67	71	75	79	59	63	67	71	75	79	59	63	67	71	75	79	59	63	67	71	75	79	59	63	67	71	75	79
	Entering Indoor Wet Bulb Temperature																																			
4388	MBh	115.6	118.1	126.2	134.9	112.9	115.4	123.3	131.8	110.2	112.7	120.4	128.7	107.6	109.9	117.4	125.5	102.2	104.4	111.5	119.2	94.6	96.7	103.3	110.5											
	S/T	0.91	0.86	0.70	0.52	0.94	0.89	0.72	0.54	0.97	0.91	0.74	0.55	1.00	0.94	0.76	0.57	1.00	1.00	0.79	0.59	1.00	1.00	0.80	0.60											
	Δ T	22	21	18	15	22	21	19	15	22	21	19	15	23	22	19	15	21	22	19	15	20	20	17	14											
	kW	10.00	10.21	10.53	10.87	10.76	11.00	11.35	11.72	11.44	11.69	12.07	12.47	12.04	12.30	12.71	13.13	12.54	12.82	13.25	13.69	12.98	13.27	13.71	14.18											
	Amps	15.9	16.2	16.6	17.2	16.9	17.3	17.8	18.3	18.2	18.6	19.1	19.7	19.2	19.6	20.2	20.9	20.3	20.7	21.3	22.1	21.4	21.8	22.5	23.2											
	HI PR	141	151	160	167	158	170	179	187	179	193	204	213	204	220	232	242	230	247	261	273	254	273	289	301											
	LO PR	60	64	70	75	64	68	74	79	66	70	77	82	70	74	81	86	73	78	85	90	75	80	88	93											
	MBh	112.3	114.7	122.6	131.0	109.6	112.0	119.7	128.0	107.0	109.4	116.9	124.9	104.4	106.7	114.0	121.9	99.2	101.4	108.3	115.8	91.9	93.9	100.3	107.2											
	S/T	0.87	0.82	0.66	0.50	0.90	0.85	0.69	0.51	0.92	0.87	0.71	0.53	0.95	0.89	0.73	0.54	0.99	0.93	0.76	0.56	1.00	0.94	0.76	0.57											
	Δ T	23	22	19	15	23	22	19	16	23	22	19	16	23	23	20	16	23	22	19	15	22	21	18	14											
kW	9.92	10.13	10.45	10.78	10.68	10.91	11.26	11.62	11.35	11.59	11.97	12.36	11.94	12.20	12.60	13.02	12.44	12.72	13.14	13.58	12.87	13.16	13.60	14.06												
Amps	15.8	16.1	16.5	17.0	16.8	17.2	17.6	18.2	18.0	18.4	18.9	19.5	19.1	19.5	20.1	20.7	20.1	20.6	21.2	21.9	21.2	21.6	22.3	23.0												
HI PR	139	150	158	165	156	168	178	185	178	191	202	211	202	218	230	240	228	245	259	270	252	271	286	298												
LO PR	60	64	69	74	63	67	73	78	66	70	76	81	69	73	80	85	72	77	84	89	75	79	87	92												
MBh	103.6	105.9	113.1	120.9	101.2	103.4	110.5	118.1	98.8	100.9	107.9	115.3	96.4	98.5	105.2	112.5	91.6	93.6	100.0	106.9	84.8	86.7	92.6	99.0												
S/T	0.84	0.79	0.64	0.48	0.87	0.81	0.66	0.50	0.89	0.84	0.68	0.51	0.92	0.86	0.70	0.52	0.95	0.90	0.73	0.54	0.96	0.90	0.73	0.55												
Δ T	23	22	20	16	24	23	20	16	24	23	20	16	24	23	20	16	24	23	20	16	22	21	18	15												
kW	9.69	9.89	10.20	10.52	10.42	10.64	10.98	11.34	11.07	11.31	11.67	12.06	11.64	11.90	12.29	12.69	12.13	12.40	12.80	13.23	12.55	12.83	13.25	13.70												
Amps	15.4	15.7	16.1	16.6	16.4	16.8	17.2	17.8	17.6	18.0	18.5	19.1	18.6	19.0	19.6	20.2	19.7	20.1	20.7	21.3	20.7	21.1	21.7	22.5												
HI PR	135	145	153	160	152	163	172	180	172	186	196	204	196	211	223	233	221	238	251	262	244	263	277	289												
LO PR	58	62	67	72	61	65	71	76	64	68	74	79	67	71	78	83	70	74	81	87	72	77	84	90												
MBh	117.6	119.9	125.6	134.0	114.9	117.1	122.7	130.9	112.2	114.3	119.8	127.8	109.4	111.6	116.8	124.6	104.0	106.0	111.0	118.4	96.3	98.2	102.8	109.7												
S/T	0.96	0.92	0.83	0.68	0.99	0.96	0.86	0.70	1.00	0.98	0.88	0.72	1.00	1.00	0.91	0.74	1.00	1.00	0.95	0.77	1.00	1.00	0.96	0.78												
Δ T	24	23	22	19	24	23	22	19	24	23	22	19	23	23	22	19	22	22	22	19	20	21	21	18												
kW	10.08	10.29	10.62	10.96	10.85	11.09	11.44	11.81	11.53	11.79	12.17	12.57	12.14	12.40	12.81	13.24	12.65	12.93	13.36	13.81	13.09	13.38	13.83	14.30												
Amps	16.0	16.3	16.8	17.3	17.1	17.4	17.9	18.5	18.3	18.7	19.2	19.9	19.4	19.8	20.4	21.0	20.5	20.9	21.5	22.2	21.5	22.0	22.6	23.4												
HI PR	142	153	161	168	159	172	181	189	181	195	206	215	206	222	235	245	232	250	264	275	257	276	292	304												
LO PR	61	65	71	75	64	68	75	80	67	71	78	83	70	75	82	87	74	78	86	91	76	81	88	94												
MBh	114.2	116.4	121.9	130.1	111.6	113.7	119.1	127.1	108.9	111.0	116.3	124.0	106.2	108.3	113.4	121.0	100.9	102.9	107.8	115.0	93.5	95.3	99.8	106.5												
S/T	0.91	0.88	0.79	0.64	0.94	0.91	0.82	0.67	0.97	0.93	0.84	0.68	1.00	0.96	0.87	0.71	1.00	1.00	0.90	0.73	1.00	1.00	0.91	0.74												
Δ T	25	24	23	20	25	24	23	20	25	24	23	20	25	25	23	20	24	24	23	20	22	22	21	19												
kW	10.00	10.21	10.53	10.87	10.76	11.00	11.35	11.72	11.44	11.69	12.07	12.47	12.04	12.30	12.71	13.13	12.54	12.82	13.25	13.69	12.98	13.27	13.71	14.18												
Amps	15.9	16.2	16.6	17.2	16.9	17.3	17.8	18.3	18.2	18.6	19.1	19.7	19.2	19.6	20.2	20.9	20.3	20.7	21.3	22.1	21.4	21.8	22.5	23.2												
HI PR	141	151	160	167	158	170	179	187	179	193	204	213	204	220	232	242	230	247	261	273	254	273	289	301												
LO PR	60	64	70	75	64	68	74	79	66	70	77	82	70	74	81	86	73	78	85	90	75	80	88	93												
MBh	105.4	107.5	112.5	120.1	103.0	105.0	109.9	117.3	100.5	102.5	107.3	114.5	98.1	100.0	104.7	111.7	93.2	95.0	99.5	106.1	86.3	88.0	92.1	98.3												
S/T	0.88	0.85	0.77	0.62	0.91	0.88	0.79	0.64	0.93	0.90	0.81	0.66	0.96	0.93	0.84	0.68	1.00	0.97	0.87	0.71	1.00	0.97	0.88	0.71												
Δ T	25	25	23	20	25	25	23	20	25	25	24	20	25	25	24	20	25	25	23	20	23	23	22	19												
kW	9.76	9.97	10.28	10.61	10.51	10.73	11.07	11.43	11.16	11.40	11.77	12.16	11.74	12.00	12.39	12.80	12.23	12.50	12.91	13.34	12.65	12.94	13.36	13.81												
Amps	15.5	15.8	16.3	16.8	16.6	16.9	17.4	17.9	17.8	18.1	18.6	19.2	18.8	19.2	19.7	20.4	19.8	20.2	20.8	21.5	20.8	21.3	21.9	22.6												
HI PR	136	147	155	162	153	165	174	181	174	187	198	206	198	213	225	235	223	240	253	264	246	265	280	292												
LO PR	59	62	68	72	62	66	72	76	64	68	75	79	67	72	78	83	71	75	82	87	73	78	85	90												

Shaded area is ACCA (TVA) conditions

IDB = Entering Indoor Dry Bulb Temperature

# DIMENSIONS

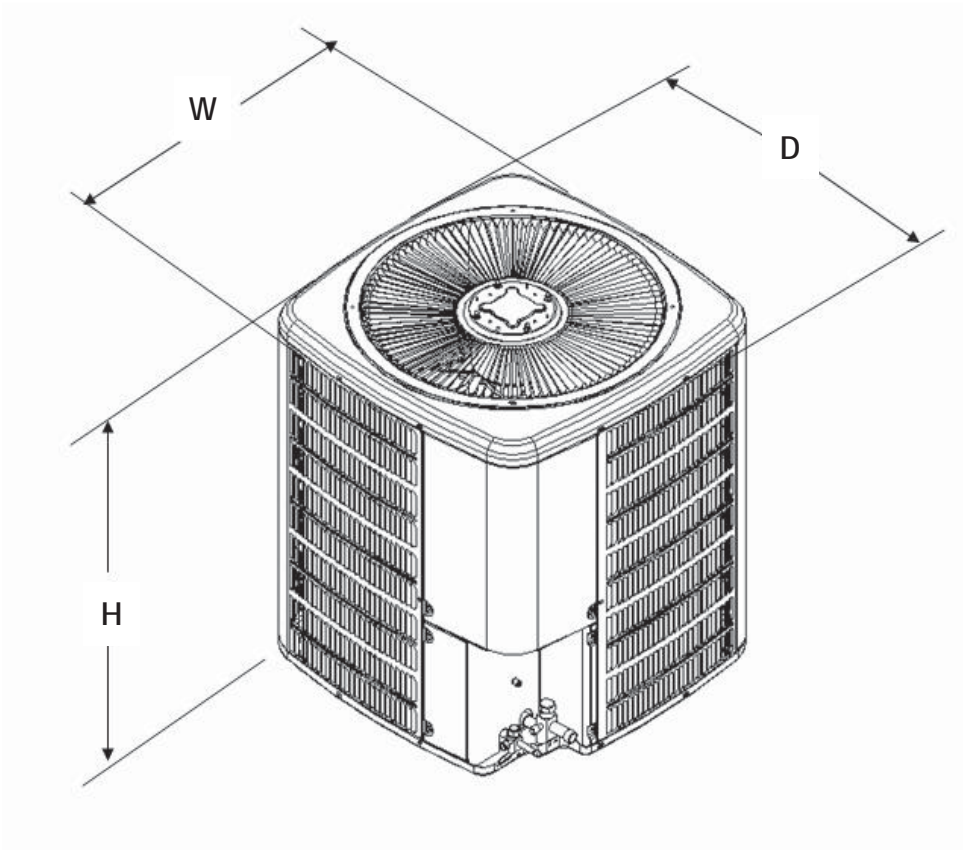

Model	Dimensions W x D x H
CE120-5	35½ x 35½ x 41½

# SCHEMATIC DIAGRAM

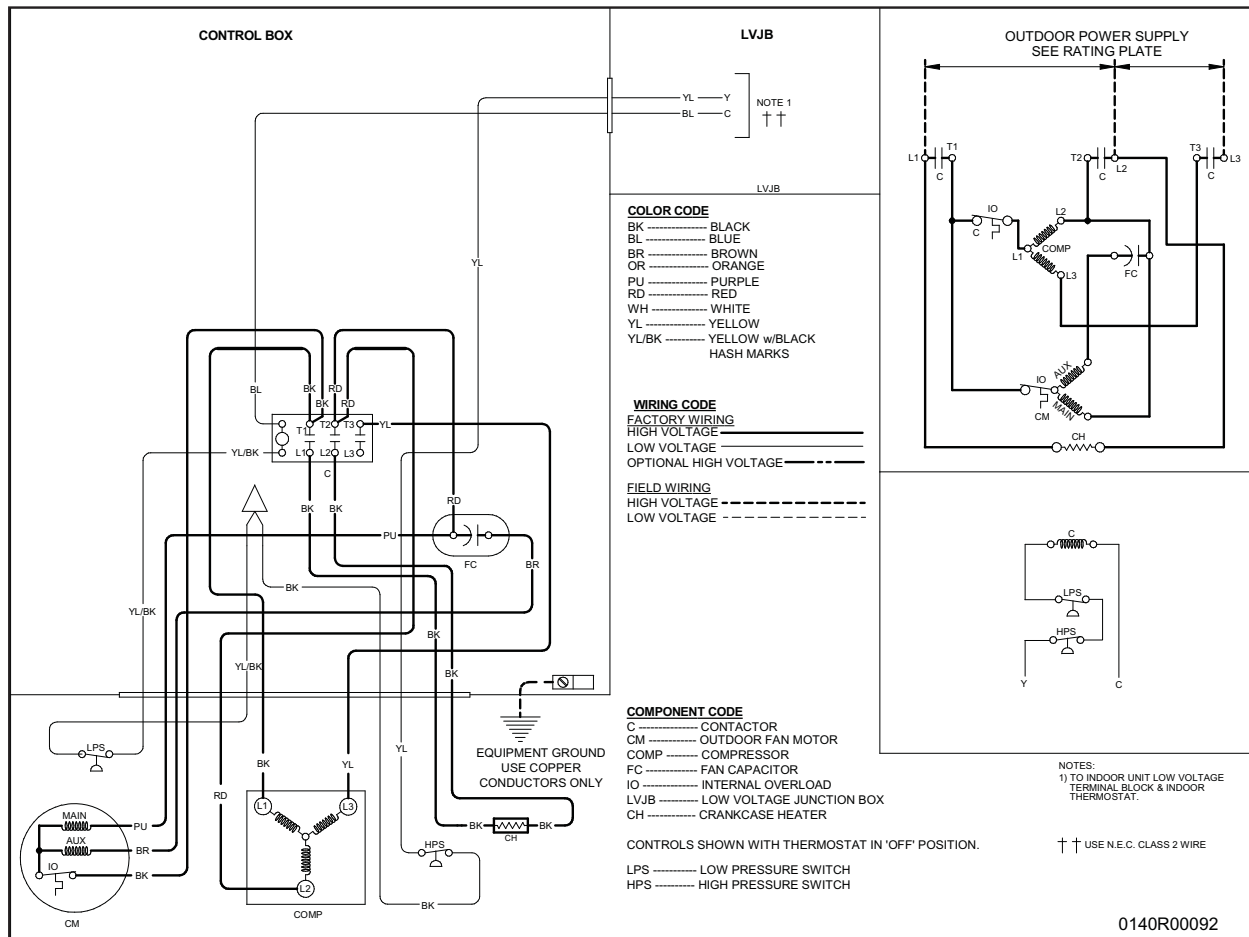

# ACCESSORIES

Model	Description
FSK01A <sup>1</sup>	Freeze Protection Kit
CHTD18-60	Digital room thermostat with 1-stage cool/1-stage heat
CHT18-60	Standard room thermostat with 1-stage cool/1-stage heat
LA-01	Low Ambient Kit

<sup>1</sup> Installed on indoor coil

# NOTES





## Free Manuals Download Website

<http://myh66.com>

<http://usermanuals.us>

<http://www.somanuals.com>

<http://www.4manuals.cc>

<http://www.manual-lib.com>

<http://www.404manual.com>

<http://www.luxmanual.com>

<http://aubethermostatmanual.com>

Golf course search by state

<http://golfingnear.com>

Email search by domain

<http://emailbydomain.com>

Auto manuals search

<http://auto.somanuals.com>

TV manuals search

<http://tv.somanuals.com>