

Goodman[®]

TECHNICAL MANUAL

GDS8 & GHS8 33-3/8" 80% Gas Furnace Units

- Refer to Service Manual RS6610004 for installation, operation, and troubleshooting information.
- All safety information must be followed as provided in the Service Manual.
- Refer to the appropriate Parts Catalog for part number information.
- Model numbers listed on page 3.

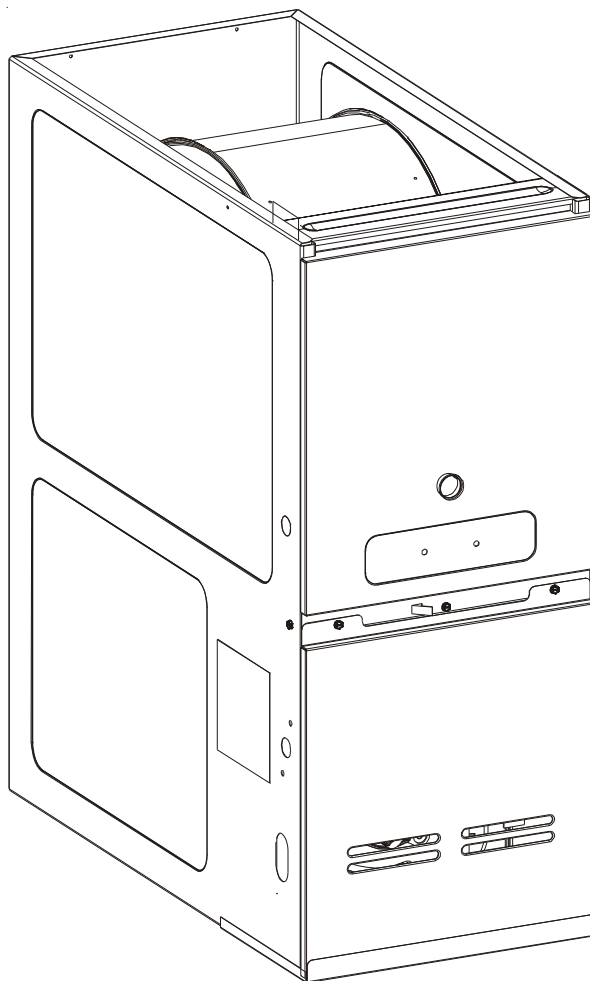

This manual is to be used by qualified, professionally trained HVAC technicians only. Goodman does not assume any responsibility for property damage or personal injury due to improper service procedures or services performed by an unqualified person.

RT6622011
September 2009

Copyright © 2009 Goodman Manufacturing Company, L.P.

PRODUCT IDENTIFICATION

The model and manufacturing number are used for positive identification of component parts used in manufacturing. Please use these numbers when requesting service or parts information.

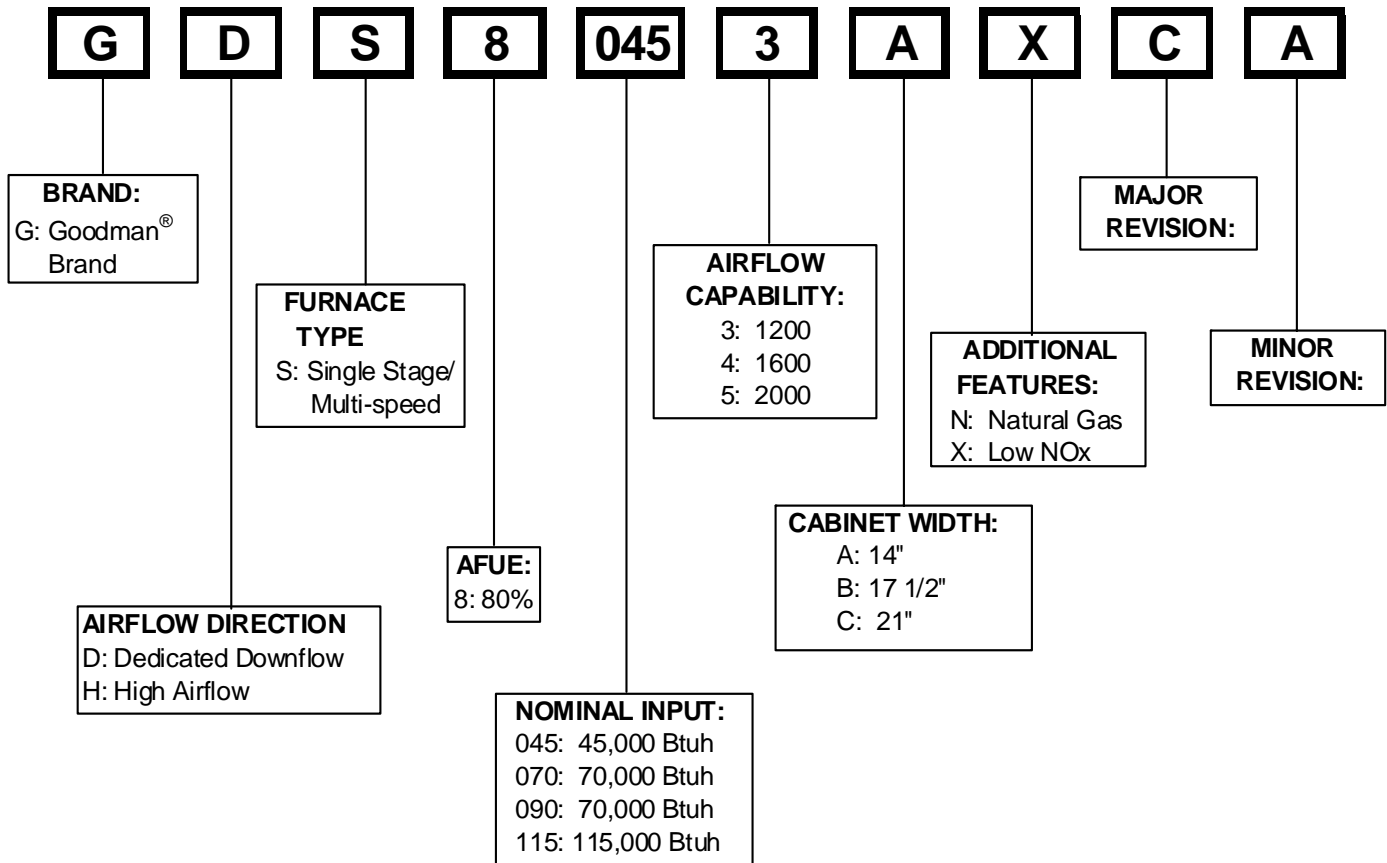

WARNING

HIGH VOLTAGE!

Disconnect ALL power before servicing or installing this unit. Multiple power sources may be present. Failure to do so may cause property damage, personal injury or death.

WARNING

Goodman will not be responsible for any injury or property damage arising from improper service or service procedures. If you install or perform service on this unit, you assume responsibility for any personal injury or property damage which may result. Many jurisdictions require a license to install or service heating and air conditioning equipment.

WARNING

Installation and repair of this unit should be performed ONLY by individuals meeting the requirements of an "entry level technician" as specified by the Air-Conditioning, Heating, and Refrigeration Institute (AHRI). Attempting to install or repair this unit without such background may result in product damage, personal injury or death.

PRODUCT IDENTIFICATION

The model and manufacturing number are used for positive identification of component parts used in manufacturing. Please use these numbers when requesting service or parts information.

GDS80453AXC*

GDS80703AXC*

GDS80904BXC*

GDS81155CXC*

GHS80453AXC*

GHS80704AXC*

GHS81155CXC*

** These models available in Low NOx*



The United States Environmental Protection Agency ("EPA") has issued various regulations regarding the introduction and disposal of refrigerants introduced into this unit. Failure to follow these regulations may harm the environment and can lead to the imposition of substantial fines. These regulations may vary by jurisdiction. Should questions arise, contact your local EPA office.



Do not connect or use any device that is not design certified by Goodman for use with this unit. Serious property damage, personal injury, reduced unit performance and/or hazardous conditions may result from the use of such non-approved devices.



To prevent the risk of property damage, personal injury, or death, do not store combustible materials or use gasoline or other flammable liquids or vapors in the vicinity of this appliance.

PRODUCT DESIGN

General Operation

The G*S8 furnaces are equipped with an electronic ignition device used to light the burners and an induced draft blower to exhaust combustion products.

An interlock switch prevents furnace operation if the inner blower door is not in place. Keep the blower access door in place except for inspection and maintenance. (See illustration on pages 5 and 6.)

This furnace is also equipped with a self-diagnosing electronic control module. In the event a furnace component is not operating properly, the control module LED will flash on and off in a factory-programmed sequence, depending on the problem encountered. This light can be viewed through the observation window in the blower access door. Refer to the *Troubleshooting Chart* for further explanation of the LED codes and *Abnormal Operation - Integrated Ignition Control* section in the Service Instructions for an explanation of the possible problem.

The rated heating capacity of the furnace should be greater than or equal to the total heat loss of the area to be heated. The total heat loss should be calculated by an approved method or in accordance with "ASHRAE Guide" or "Manual J-Load Calculations" published by the Air Conditioning Contractors of America.

*Obtain from: American National Standards Institute 1430 Broadway New York, NY 10018

Location Considerations

- The furnace should be as centralized as is practical with respect to the air distribution system.
- Do not install the furnace directly on carpeting, tile, or combustible material other than wood flooring.
- When installed in a residential garage, the furnace must be positioned so the burners and ignition source are located not less than 18 inches (457 mm) above the floor and protected from physical damage by vehicles.

Notes:

 WARNING
<p>TO PREVENT POSSIBLE PERSONAL INJURY OR DEATH DUE TO ASPHYXIATION, THIS FURNACE MUST BE CATEGORY I VENTED. DO NOT VENT USING CATEGORY III VENTING.</p>

Category I Venting is venting at a non-positive pressure. A furnace vented as Category I is considered a fan-assisted appliance and the vent system does not have to be "gas tight." **NOTE:** Single stage gas furnaces with induced draft blowers draw products of combustion through a heat exchanger allowing, in some instances, common venting with natural draft appliances (i.e. water heaters). All installations must be vented in accordance with National Fuel Gas Code

NFPA 54/ANSI Z223.1 - latest edition. In Canada, the furnaces must be vented in accordance with the National Standard of Canada, CAN/CSA B149.1 and CAN/CSA B149.2 - latest editions and amendments.

NOTE: The vertical height of the Category I venting system must be at least as great as the horizontal length of the venting system.

Accessibility Clearances (Minimum)

Unobstructed front clearance of 24" for servicing is recommended.

MINIMUM CLEARANCE TO COMBUSTIBLE MATERIALS - INCHES

Sides	Rear	Front*	Vent		Top
			SW	B	
1	0	3	6	1	1

* 24" clearance for serviceability recommended.

** Single Wall Vent (SW) to be used only as a connector.

Refer to the venting tables outlined in the Installation Manual for additional venting requirements.

Note: In all cases accessibility clearance shall take precedence over clearances from the enclosure where accessibility clearances are greater. All dimensions are given in inches.

High Altitude Derate

When this furnace is installed at high altitude, the appropriate High Altitude orifice kit must be installed. This is required due to the natural reduction in the density of both the gas fuel and combustion air as altitude increases. The kit will provide the proper design certified input rate within the specified altitude range.

INPUT PER BURNER - 22,500 BTUH NATURAL GAS / 20,000 BTUH L.P.								
	ELEVATION ABOVE SEA-LEVEL (FEET)							
	2000	3000	4000	4500	5000	6000	7000	8000
US BURNER ORIFICE	44/55	44/55	45/56		45/56	46/57	47/58	47/58
CANADA BURNER ORIFICE	44/55			47/57				

HA-02 HIGH ALTITUDE CONVERSION KIT REQUIRED

Tabled data is based upon the furnace input being reduced for altitudes above sea level. U.S. 4% per 1,000 feet. Canada 10% derate for 2,000-4,000 feet.

High altitude kits are purchased according to the installation altitude and usage of either natural or propane gas. Refer to the chart above for a tabular listing of appropriate altitude ranges and corresponding manufacturer's high altitude Natural Gas and Propane Gas kits. For a tabular listing of appropriate altitude ranges and corresponding manufacturer's High Altitude Pressure Switch kits, refer to either the *Pressure Switch Trip Points & Usage Chart* in this manual or the *Accessory Charts* in Service Instructions.

PRODUCT DIMENSIONS

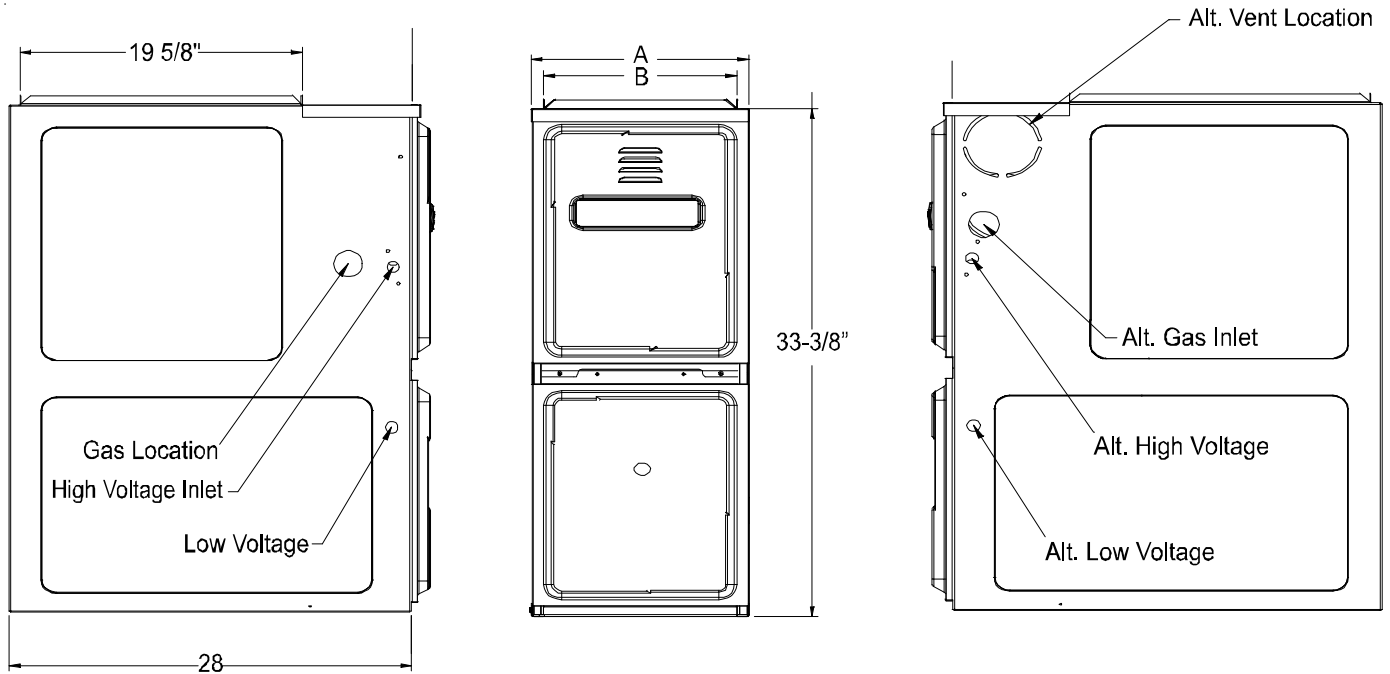

MODEL	A	B
GHS80453AXC*	14 1/2"	12 1/2"
GHS80704BXC*	17 1/2"	16"
GHS80905CXC*	21"	19 1/2"

MODEL	A	B
GDS80453AXC*	14 1/2"	12 1/2"
GDS80703AXC*	17 1/2"	16"
GDS80904BXC*	21"	19 1/2"
GDS81155CXC*	21"	19 1/2"

Pressure Switch Trip Points And Usage Chart		
Model	Trip Point ID Blower Pressure Switch	ID Blower Pressure Switch Part #
GHS80453AXC*	-0.80	0130F00042
GHS80704BXC*	-0.70	B1370158
GHS80905CXC*	-0.70	B1370158

For installations in Canada, the GHS furnaces are certified only to 4,500 ft.

* Negative pressure readings are in inches of water column (*w.c.)

PRIMARY LIMIT		
Part Number	0130M00063	20162903
Open Setting (°F)	140	120
GHS80453AXC*	1	--
GHS80704BXC*	--	1
GHS80905CXC*	1	--

ROLLOUT LIMIT SWITCHES	
Part Number	B1370145
Open Setting (°F)	300
GHS80453AXC*	2
GHS80704BXC*	2
GHS80905CXC*	2

AUXILIARY LIMIT SWITCHES	
Part Number	0130F00038
Open Setting (°F)	120
GHS80453AXC*	1
GHS80704BXC*	1
GHS80905CXC*	1

Presssure Switches		
Model	Part No.	Opens*
GDS80453AXC*	B1370142	-0.60
GDS80703AXC*	B137158	-0.70
GDS80904BXC*	B1370142	-0.60
GDS81155CXC*	B137158	-0.70

PRIMARY LIMIT		
Part Number	0130F00035	0130F00036
Open Setting (°F)	220	180
GDS80453AXC*	1	--
GDS80703AXC*	1	--
GDS80904BXC*	--	1
GDS81155CXC*	--	1

ROLLOUT LIMIT SWITCHES	
Part Number	B1370145
Open Setting (°F)	300
GDS80453AXC*	2
GDS80703AXC*	2
GDS80904BXC*	2
GDS81155CXC*	2

AUXILIARY LIMIT SWITCHES	
Part Number	0130F00038
Open Setting (°F)	120
GDS80453AXC*	1
GDS80703AXC*	1
GDS80904BXC*	1
GDS81155CXC*	1

PRODUCT DESIGN

Coil Matches:

A large array of Amana® brand coils are available for use with the GHS8 furnaces, in horizontal applications and for the GDS8 for downflow applications. These coils are available in both cased and uncased models (with the option of a field installed TXV expansion device). These 80% furnaces match up with the existing Amana® brand coils as shown below.

Coil Matches (for Goodman® units using R22 and R-410A):

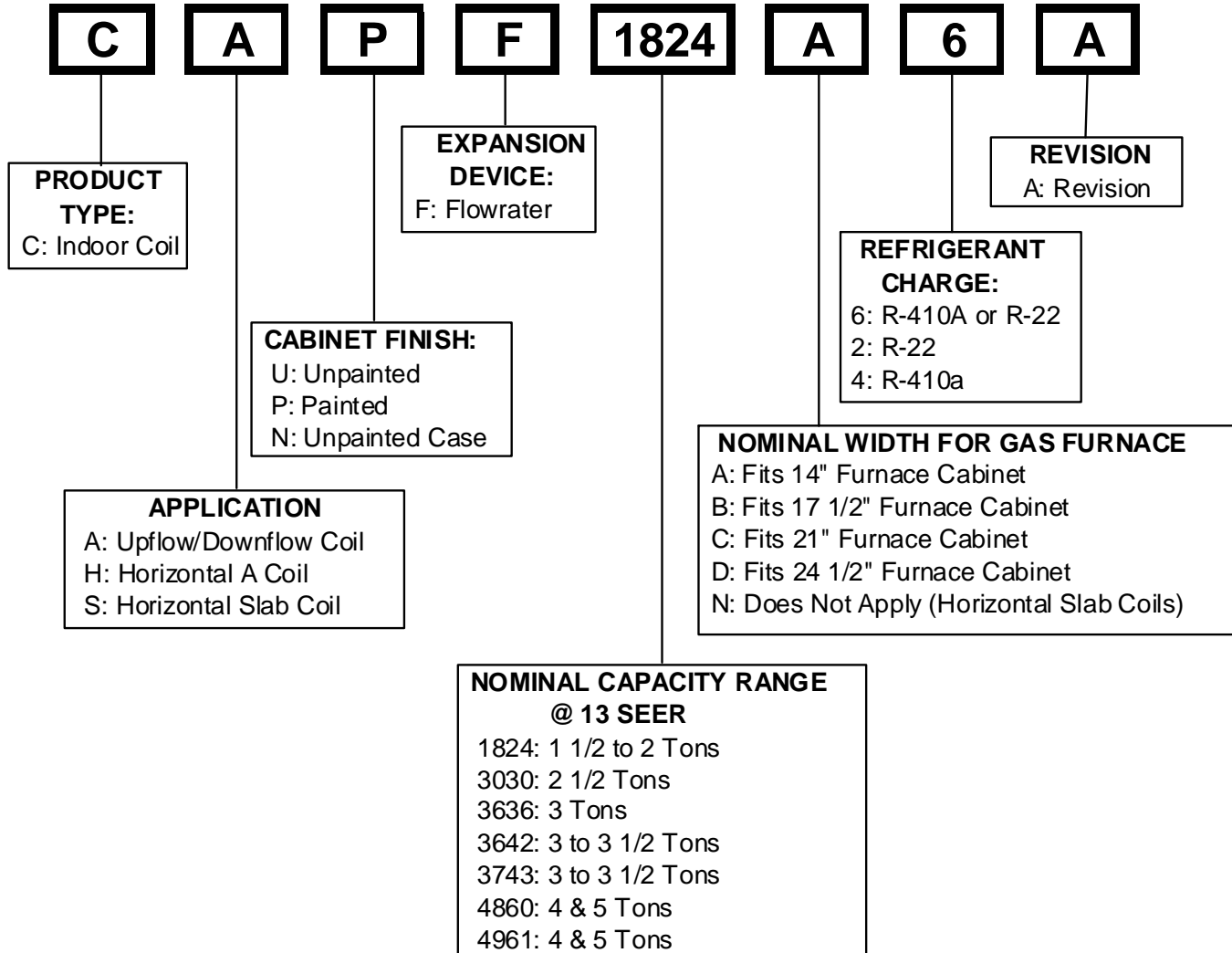

- All CAPF coils in B, C, & D widths have insulated blank off plates for use with one size smaller furnaces.
- All CAPF coils have a CAUF equivalent.
- All CHPF coils in B, C & D heights have an insulated Z bracket for use with one size smaller furnace.
- All proper coil combinations are subject to being AHRI rated with a matched outdoor unit.

PRODUCT DESIGN

Thermostats:

NOTE: Complete lineup of thermostats can be found in the Thermostat Specification Sheets.

Filters:

Filters are required with this furnace and must be provided by the installer. The filters used must comply with UL900 or CAN/ULCS111 standards. Installing this furnace without filters will void the unit warranty

Upflow Filters

This furnace has provisions for the installation of return air filters at the side and/or bottom return. The furnace will accommodate the following filter sizes depending on cabinet size:

SIDE RETURN		
Cabinet Width (in.)	Nominal Filter Size (in.)	Approx. Flow Area (in ²)
All	16 x 25 x 1	400

BOTTOM RETURN		
Cabinet Width (in.)	Nominal Filter Size (in.)	Approx. Flow Area (in ²)
17-1/2	14 x 25 x 1	350
21	16 x 25 x 1	400
24-1/2	20 x 25 x 1	500

Refer to Minimum Filter Area tables to determine filter area requirement. **NOTE:** Filters can also be installed elsewhere in the duct system such as a central return.

		UPFLOW COOLING AIRFLOW REQUIREMENT (CFM)						
		600	800	1000	1200	1400	1600	2000
Input Airflow	0704__XA	---	---	564*	564*	672	768	
	0905__XA	---	---	---	752*	752*	768	960
	1155__XA	---	---	---	940*	940*	940*	960

		COUNTERFLOW COOLING AIRFLOW REQUIREMENT (CFM)						
		600	800	1000	1200	1400	1600	2000
Input Airflow	0704__XA	---	---	641*	641*	672	768	---
	0905__XA	---	---	---	854*	854*	854*	960

		UPFLOW COOLING AIRFLOW REQUIREMENT (CFM)						
		600	800	1000	1200	1400	1600	2000
Input Airflow	0704__XA	---	---	627*	627*	672	768	---
	0905__XA	---	---	---	836*	836*	836*	960
	1155__XA	---	---	---	940*	940*	940*	960

		COUNTERFLOW COOLING AIRFLOW REQUIREMENT (CFM)						
		600	800	1000	1200	1400	1600	2000
Input Airflow	0704__XA	---	---	320*	320*	336	384	---
	0905__XA	---	---	---	427*	427*	427*	480

*Minimum filter area dictated by heating airflow requirement.

*Minimum filter area dictated by heating airflow requirement.

Disposable Minimum Filter Area (in²)
[Based on a 300 ft/min filter face velocity]

Permanent Minimum Filter Area (in²)
[Based on 600 ft/min filter face velocity]

PRODUCT DESIGN

Counterflow Filters

This furnace has provisions for the installation of return air filters at the counterflow top return. The furnace will accommodate the following filter sizes depending on cabinet size:

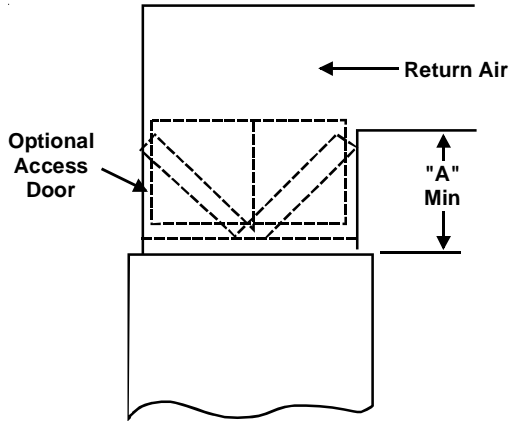

Counterflow Top Return				
Cabinet Width	Filter Area (in ²)	Qty	Filter Size (in)	Dimension "A" (in)
21	600	2	15 X 20 X 1	13.0
24 1/2				11.3
21	800	2	20 X 20 X 1	18.8
24 1/2				17.7
21	1000	2	25 X 20 X 1	24.3
24 1/2				23.4

Refer to Minimum Filter Area tables to determine filter area requirement. **NOTE:** Filters can also be installed elsewhere in the duct system such as a central return.

FURNACE SPECIFICATIONS

GDS8

MODEL	GDS80453AXC*	GDS80703AXC*	GDS80904BXC*	GDS81155CXC*
Btuh Input (US) High Fire ⁽¹⁾	45,000	70,000	90,000	115,000
Output (US) High Fire ⁽¹⁾	36,000	56,000	72,000	92,000
A.F.U.E. ⁽²⁾	80%	80%	80%	80%
Rated External Static (" w.c.)	.20 - .50	.20 - .50	.20 - .50	.20 - .50
Temperature Rise (°F)	35-65	30-60	35-65	40 - 70
Pressure Switch Trip Point (" w.c.)	-0.60	-0.70	-0.60	-0.70
Blower Wheel (D" x W")	10 X 6	10 x 6	10 x 8	10 x 10
Blower Horsepower	1/3	1/3	1/2	3/4
Blower Speeds Max CFM @ 0.5 E.S.P.	Refer to airflow charts.			
Power Supply	115-60-1	115-60-1	115-60-1	115-60-1
Minimum Circuit Ampacity (MCA) ⁽⁴⁾	8.5	8.5	12.9	12.9
Maximum Overcurrent Device ⁽⁵⁾	15	15	15	15
Transformer (VA)	40	40	40	40
Heat Anticipator (Amps)	0.7	0.7	0.7	0.7
Primary Limit Setting (°F)	220	220	180	180
Auxiliary Limit Setting (°F)	120	120	120	120
Rollout Limit Setting (°F)	300	300	300	300
Gas Supply Pressure (Natural/Propane) (" w.c.)	7 / 11	7 / 11	7 / 11	7 / 11
Manifold Pressure (Natural/Propane) High Stage (" w.c.)	3.5 / 10	3.5 / 10	3.5 / 10	3.5 / 10
Orifice Size (Natural/Propane)	#43 / #55	#43 / #55	#43 / #55	#43 / #55
Number of Burners	2	3	4	5
Vent Connector Diameter (inches) ⁽³⁾	4	4	4	4
Shipping Weight (lbs.)	120	130	153	175

1 Natural Gas BTU/h. For altitudes above 2,000', reduce input rating 4% for each 1,000' above sea level.

2 DOE AFUE based upon Isolated Combustion System (ICS)

3 Vent and combustion air diameters may vary depending upon vent length.

Refer to the latest editions of the National Fuel Gas Code NFPA 54/ANSI Z223.1 (in the USA) and the Canada National Standard of Canada, CAN/CSA B149.1 and CAN/CSA B142.2 (in Canada).

4 Minimum Circuit Ampacity = (1.25 x Circulator Blower Amps) + ID Blower amps. Wire size should be determined in accordance with National Electrical Codes. Extensive wire runs will require larger wire sizes.

5 Maximum Overcurrent Protection Device refers to maximum recommended fuse or circuit breaker size. May use fuses or HACR-type circuit breakers of the same size as noted.

Notes:

- All furnaces are manufactured for use on 115 VAC, 60 Hz, single-phase electrical supply.
- Gas Service Connection ½" FPT
- Important: Size fuses and wires properly and make electrical connections in accordance with the National Electrical Code and/or all existing local codes.

NOTES:

- * These furnaces are manufactured for natural gas operation. Optional Kits are available for conversion to propane gas operation.
- * For elevations above 2000 ft. the rating should be reduced by 4% for each 1000 ft. above sea level. The furnace must not be derated, orifice changes should only be made if necessary for altitude.
- * The total heat loss from the structure as expressed in TOTAL BTU/HR must be calculated by the manufactures method in accordance with the "A.S.H.R.A.E. GUIDE" or "MANUAL J-LOAD CALCULATIONS" published by the AIR CONDITIONING CONTRACTORS OF AMERICA. The total heat loss calculated should be equal to or less than the heating capacity. Output based on D.O.E. test procedures, steady state efficiency times output.

Unit specifications are subject to change without notice. **ALWAYS** refer to the unit's serial plate for the most up-to-date general and electrical information.

FURNACE SPECIFICATIONS

GHS8

MODEL	GHS80453AXC*	GHS80704BXC*	GHS80905CXC*
Input, Natural Gas (BTUH) ⁽¹⁾	45,000	70,000	90,000
Output, Natural Gas (BTUH) ⁽¹⁾	36,000	56,000	72,000
Output, LP (BTUH)	32,000	48,000	64,000
A.F.U.E. ⁽²⁾	80.0%	80.0%	80.0%
Rated External Static (" w.c.)	0.20 - 0.50	0.20 - 0.50	0.20 - 0.50
Temperature Rise (°F)	15 - 45	30 - 60	35 - 65
Pressure Switch Trip Point (" w.c.)	-0.80	-0.70	-0.70
Blower Wheel (D" x W")	11" x 6"	11" x 8"	11" x 10"
Blower Horsepower	1/2	3/4	3/4
Blower Speeds Max CFM @ 0.5 E.S.P.	Refer to airflow charts.		
Power Supply (Volts/Hz/Ph)	115/60/1	115/60/1	115/60/1
Minimum Circuit Ampacity (MCA) ⁽⁴⁾	12.5	11.8	11.8
Maximum Overcurrent Device ⁽⁵⁾	15	15	15
Transformer (VA)	40	40	40
ID Blower Pressure Switch Trip Point (" w.c.)	-0.80	-0.70	-0.70
Primary Limit Setting (°F)	140	120	140
Auxiliary Limit Setting (°F)	120	120	120
Rollout Limit Setting (°F)	300	300	300
Gas Supply Pressure (Natural/Propane) (" w.c.)	7 / 11	7 / 11	7 / 11
Manifold Pressure (Natural/Propane) (" w.c.)	3.5 / 10	3.5 / 10	3.5 / 10
Orifice Size (Natural/Propane)	43 / 55	43 / 55	43 / 55
Number of Burners	2	3	4
Vent Connector Diameter (inches) ⁽³⁾	4	4	4
Shipping Weight (lbs.)	120	130	153

1 Natural Gas BTU/h. For altitudes above 2,000', reduce input rating 4% for each 1,000' above sea level.

2 DOE AFUE based upon Isolated Combustion System (ICS)

3 Vent and combustion air diameters may vary depending upon vent length.

Refer to the latest editions of the National Fuel Gas Code NFPA 54/ANSI Z223.1 (in the USA) and the Canada National Standard of Canada, CAN/CSA B149.1 and CAN/CSA B142.2 (in Canada).

4 Minimum Circuit Ampacity = (1.25 x Circulator Blower Amps) + ID Blower amps. Wire size should be determined in accordance with National Electrical Codes. Extensive wire runs will require larger wire sizes.

5 Maximum Overcurrent Protection Device refers to maximum recommended fuse or circuit breaker size. May use fuses or HACR-type circuit breakers of the same size as noted.

Notes:

- All furnaces are manufactured for use on 115 VAC, 60 Hz, single-phase electrical supply.
- Gas Service Connection ½" FPT
- Important: Size fuses and wires properly and make electrical connections in accordance with the National Electrical Code and/or all existing local codes.

NOTES:

- * These furnaces are manufactured for natural gas operation. Optional Kits are available for conversion to propane gas operation.
- * For elevations above 2000 ft. the rating should be reduced by 4% for each 1000 ft. above sea level. The furnace must not be derated, orifice changes should only be made if necessary for altitude.
- * The total heat loss from the structure as expressed in TOTAL BTU/HR must be calculated by the manufactures method in accordance with the "A.S.H.R.A.E. GUIDE" or "MANUAL J-LOAD CALCULATIONS" published by the AIR CONDITIONING CONTRACTORS OF AMERICA. The total heat loss calculated should be equal to or less than the heating capacity. Output based on D.O.E. test procedures, steady state efficiency times output.

Unit specifications are subject to change without notice. **ALWAYS** refer to the unit's serial plate for the most up-to-date general and electrical information.

BLOWER PERFORMANCE SPECIFICATIONS

GHS8

BLOWER PERFORMANCE (CFM & Temperature Rise vs. External Static Pressure)															
Model (Heating Speed As Shipped)	Motor Speed	Tons AC at 0.5" ESP	EXTERNAL STATIC PRESSURE (Inches Water Column)												
			0.1		0.2		0.3		0.4		0.5		0.6	0.7	0.8
			CFM	RISE	CFM	RISE	CFM	RISE	CFM	RISE	CFM	RISE	CFM	CFM	CFM
GHS8 0453AXC (Med) ²	High	3.0	1,739	19	1,656	20	1,601	21	1,551	21	1,513	22	1,460	1,413	1,353
	Med	2.5	1,422	23	1,399	24	1,378	24	1,350	25	1,305	26	1,275	1,220	1,178
	Med-Lo	2.0	1,207	28	1,213	27	1,197	28	1,169	29	1,158	29	1,131	1,103	1,068
	Low	1.5	991	34	980	34	958	35	950	35	937	36	924	910	874
GHS8 0704BXC (Med) ²	High	4.0	2,097	25	2,068	25	2,012	26	1,939	27	1,869	28	1,795	1,718	1,631
	Med	3.5	1,596	32	1,566	33	1,534	34	1,492	35	1,445	36	1,401	1,354	1,288
	Med-Lo	3.0	1,380	38	1,356	38	1,328	39	1,303	40	1,274	41	1,239	1,192	1,127
	Low	3.0	1,239	42	1,191	44	1,165	45	1,133	46	1,104	47	1,082	1,040	996
GHS8 0905CXC (Med) ²	High	5.0	2,382	28	2,315	29	2,234	30	2,158	31	2,078	32	1,971	1,866	1,762
	Med	4.0	1,622	41	1,603	42	1,583	42	1,556	43	1,516	44	1,482	1,422	1,359
	Med-Lo	3.5	1,436	46	1,391	48	1,387	48	1,356	49	1,325	50	1,279	1,239	1,180
	Low	3.0	1,240	54	1,214	55	1,191	56	1,157	58	1,120	60	1,083	1,052	1,025

NOTES:

- CFM in chart is without filter(s). Filters do not ship with this furnace, but must be provided by the installer.
- All furnaces ship as high-speed cooling. Installer must adjust blower cooling speed as needed.
- For most jobs, about 400 CFM per ton when cooling is desirable
- INSTALLATION IS TO BE ADJUSTED TO OBTAIN TEMPERATURE RISE WITHIN THE RANGE SPECIFIED ON THE RATING PLATE.
- The chart is for information only. For satisfactory operation, external static pressure must not exceed values shown on the rating plate. The shaded area indicates ranges in excess of maximum static pressure allowed when heating.
- The dashed (---) areas indicate a temperature rise not recommended for this model.
- The above chart is for U.S. furnaces installed at 0' - 2,000'. At higher altitudes, a properly de-rated unit will have approximately the same temperature rise at a particular CFM, while ESP at the CFM will be lower.

BLOWER PERFORMANCE SPECIFICATIONS

GDS8

BLOWER PERFORMANCE															
(CFM & Temperature Rise vs. External Static Pressure)															
Model (Heating Speed As Shipped)	Motor Speed	Tons AC at 0.5" ESP	EXTERNAL STATIC PRESSURE (Inches Water Column)												
			0.1		0.2		0.3		0.4		0.5		0.6	0.7	0.8
			CFM	RISE	CFM	RISE	CFM	RISE	CFM	RISE	CFM	RISE	CFM	CFM	CFM
GDS8 0453AXC (Med) ²	HIGH	3.0	1,353	25	1,290	26	1,246	27	1,199	28	1,149	29	1,116	1,116	1,099
	MED	2.5	1,183	28	1,113	30	1,098	30	1,052	32	1,039	32	1,006	1,012	969
	MED-LO	2.0	980	34	946	35	920	36	900	37	896	37	885	855	804
	LOW	1.5	778	43	762	44	738	45	746	45	738	45	717	696	678
GDS8 0703AXC (Med) ²	HIGH	3.0	1,290	40	1,236	42	1,194	43	1,166	44	1,176	44	1,166	1,108	1,029
	MED	2.5	1,139	46	1,090	48	1,035	50	1,063	49	1,063	49	1,020	962	895
	MED-LO	2.0	962	54	927	56	925	56	941	55	909	57	877	834	779
	LOW	1.5	787	66	776	67	763	68	744	70	723	72	690	641	581
GDS8 0904BXC (Med) ²	HIGH	4.0	2,128	31	2,063	32	2,001	33	1,927	35	1,824	37	1,726	1,628	1,529
	MED	3.5	1,840	36	1,788	37	1,745	38	1,689	39	1,625	41	1,550	1,470	1,364
	MED-LO	3.0	1,602	42	1,558	43	1,543	43	1,493	45	1,455	46	1,402	1,328	1,239
	LOW	2.5	1,277	52	1,252	53	1,244	54	1,229	54	1,214	55	1,179	1,141	1,079
GDS8 1155CXC (Med) ²	HIGH	5.0	2,405	35	2,361	36	2,250	38	2,161	39	2,037	42	1,937	1,808	1,689
	MED	4.0	1,880	45	1,838	46	1,794	47	1,734	49	1,677	51	1,568	1,510	1,401
	MED-LO	3.5	1,659	51	1,630	52	1,587	54	1,537	55	1,492	57	1,445	1,368	1,287
	LOW	3.0	1,472	58	1,454	59	1,404	61	1,366	62	1,326	64	1,300	1,228	1,139

NOTES:

- CFM in chart is without filter(s). Filters do not ship with this furnace, but must be provided by the installer.
- All furnaces ship as high-speed cooling. Installer must adjust blower cooling speed as needed.
- For most jobs, about 400 CFM per ton when cooling is desirable
- INSTALLATION IS TO BE ADJUSTED TO OBTAIN TEMPERATURE RISE WITHIN THE RANGE SPECIFIED ON THE RATING PLATE.
- The chart is for information only. For satisfactory operation, external static pressure must not exceed values shown on the rating plate. The shaded area indicates ranges in excess of maximum static pressure allowed when heating.
- The dashed (---) areas indicate a temperature rise not recommended for this model.
- The above chart is for U.S. furnaces installed at 0' - 2,000'. At higher altitudes, a properly de-rated unit will have approximately the same temperature rise at a particular CFM, while ESP at the CFM will be lower.

BLOWER PERFORMANCE SPECIFICATIONS

BTU OUTPUT vs TEMPERATURE RISE CHART

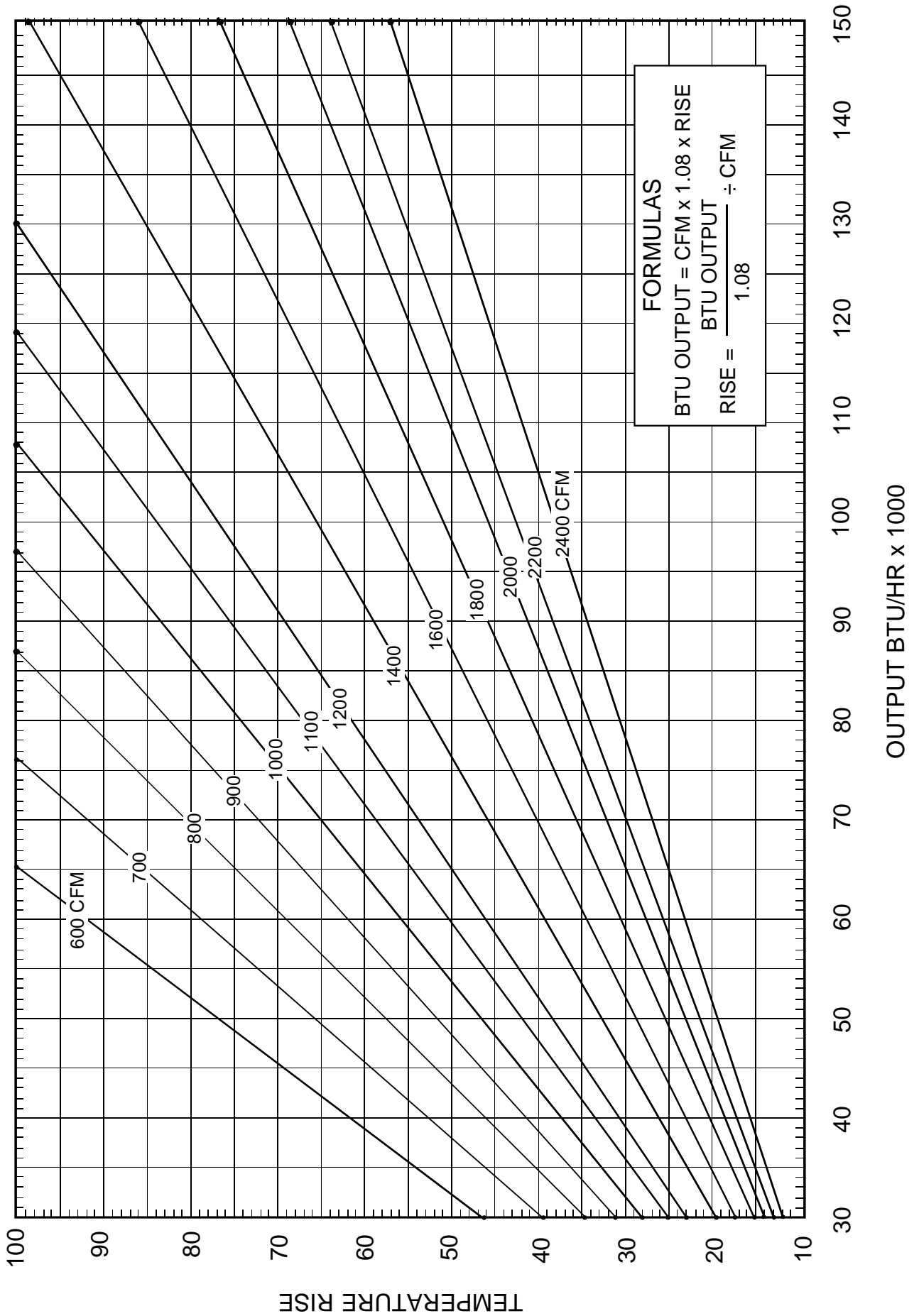

Free Manuals Download Website

<http://myh66.com>

<http://usermanuals.us>

<http://www.somanuals.com>

<http://www.4manuals.cc>

<http://www.manual-lib.com>

<http://www.404manual.com>

<http://www.luxmanual.com>

<http://aubethermostatmanual.com>

Golf course search by state

<http://golfingnear.com>

Email search by domain

<http://emailbydomain.com>

Auto manuals search

<http://auto.somanuals.com>

TV manuals search

<http://tv.somanuals.com>