

REPAIR PARTS

Light Commercial 3 - 6 Ton Belt Drive Packaged Coolers

CPC036XXX3BXJXBA
CPC036XXX3BXXXBA
CPC036XXX4BXJXBA
CPC036XXX4BXXXBA
CPC048XXX3BXJXBA
CPC048XXX3BXXXBA
CPC048XXX4BXJXBA
CPC048XXX4BXXXBA
CPC048XXX7BXJXBA
CPC048XXX7BXXXBA
CPC060XXX3BXJXBA
CPC060XXX3BXXXBA
CPC060XXX4BXJXBA
CPC060XXX4BXXXBA
CPC060XXX7BXJXBA
CPC060XXX7BXXXBA
CPC072XXX3BXJXBA
CPC072XXX3BXXXBA
CPC072XXX4BXJXBA
CPC072XXX4BXXXBA
CPC072XXX7BXJXBA
CPC072XXX7BXXXBA

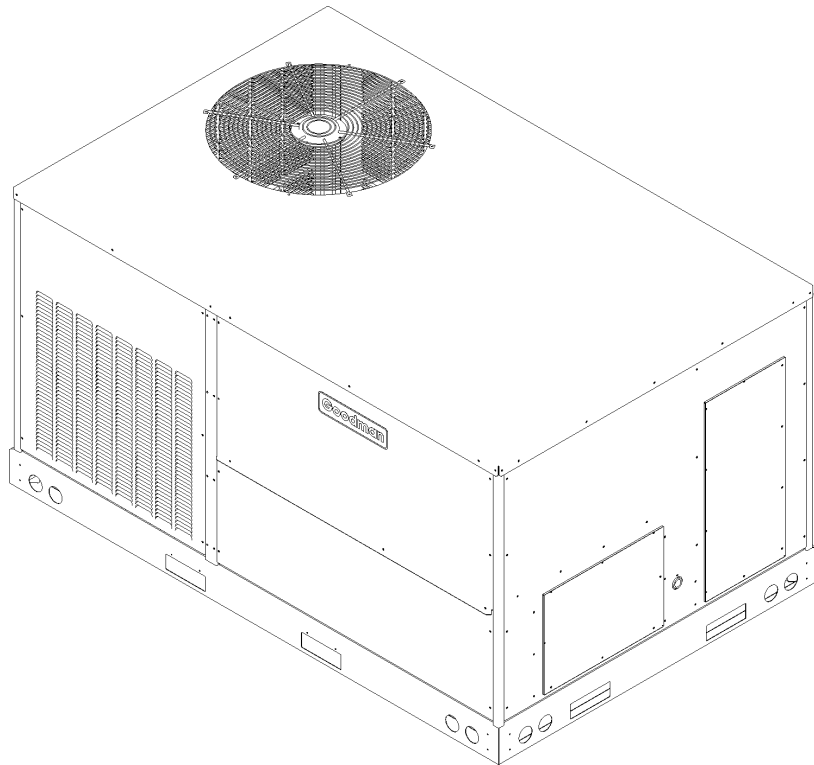

This manual is to be used by qualified technicians only.

This manual replaces RP-480A

© 2008-2009 Goodman Manufacturing Company, L.P. ♦ 5151 San Felipe, Suite 500 ♦ Houston, TX 77056

Important Information

Index

Functional Parts List	3
Illustration and Parts	4 - 13

Views shown are for parts illustrations only, not servicing procedures.

Rev. A: Added 6 ton models.

Text Codes:

AR - As Required

NA - Not Available

NS - Not Shown

00000000 - See Note

QTY - Quantity Example (QTY 3) (If Quantity not shown, Quantity = 1)

M - Model Example (M1) (If M Code not shown, then part is used on all Models)

Expanded Model Nomenclature:

Example M1 - Model#1 M2 - Model#2 M3 - Model#3

Goodman Manufacturing Company, L.P. is not responsible for personal injury or property damage resulting from improper service. Review all service information before beginning repairs.

Warranty service must be performed by an authorized technician, using authorized factory parts. If service is required after the warranty expires, Goodman Manufacturing Company, L.P. also recommends contacting an authorized technician and using authorized factory parts.

Goodman Manufacturing Company, L.P. reserves the right to discontinue, or change at any time, specifications or designs without notice or without incurring obligations.

For assistance within the U.S.A. contact:
Consumer Affairs Department
Goodman Manufacturing Company, L.P.
7401 Security Way
Houston, Texas 77040
877-254-4729-Telephone
713-863-2382-Facsimile

For assistance outside the U.S.A. contact:
International Division
Goodman Manufacturing Company, L.P.
7401 Security Way
Houston, Texas 77040
713-861-2500-Telephone
713-863-2382-Facsimile

Functional Parts

Part

No: Description:

B3240007	BELT DRIVE MOTOR (230/460)/60/3P (M17, M18, M19, M20)
0131L00003S	BELT DRIVE MOTOR 1 HP (M1, M2, M3, M4, M5, M6, M7, M8, M11, M12, M13, M14)
0131L00004S	BELT DRIVE MOTOR 1.5 HP 575V (M9, M10, M15, M16, M21, M22)
PCBFM103S	BOARD, ELECTRONIC BLOWER TIME DELAY RELAY
CAP050000370VAS	CAPACITOR 5/370V
ZP31K5ETF5830	COMPRESSOR 31200, 200/230/60/3 (M1, M2)
ZP31K5ETFD830	COMPRESSOR 31200, 460/60/3 (M3, M4)
ZP39K5ETF5830	COMPRESSOR 39000, 200/230/60/3 (M5, M6)
ZP39K5ETFD830	COMPRESSOR 39000, 460/60/3 (M7, M8)
ZP39K5ETFE830	COMPRESSOR 39000, 575/60/3 (M9, M10)
ZP51K5ETF5830	COMPRESSOR 51000, 208/230/60/3 (M11, M12)
ZP51K5ETFD830	COMPRESSOR 51000, 460/60/3 (M13, M14)
ZP51K5ETFE830	COMPRESSOR 51000, 575/60/3 (M15, M16)
ZP61KCETF5830	COMPRESSOR 61500, 200/230/60/3 (M17, M18)
ZP61KCETFD830	COMPRESSOR 61500, 460/60/3 (M19, M20)
ZP61KCETFE830	COMPRESSOR 61500, 575/60/3 (M21, M22)
0131M00008PS	COND MOTOR 1/3 HP, 1 SP, 6 PL (M17, M18)
B13400249S	COND MOTOR 1/3 HP, 460V (M19, M20)
0131M00007PS	COND MOTOR 1/4 HP, 1 SP, 6 PL (M1, M2, M5, M6, M11, M12)
B13400269S	COND MOTOR 380/460 50/60 CYCLE (M3, M4, M7, M8, M13, M14)
0131M00098S	COND MOTOR 575V (M9, M10, M15, M16)
0131M00100S	COND MOTOR 575V (M21, M22)
CONT3P025024VS	CONTACTOR 25 AMP, 3P, 24V (M3, M4, M7, M8, M9, M10, M13, M14, M15, M16, M19, M20, M21, M22)
CONT3P030024VS	CONTACTOR 30 AMP, 3P, 24V (M1, M2, M5, M6, M11, M12, M17, M18)
0130M00055	CUT-OUT SWITCH, HIGH PRESSURE
0130L00007	CUT-OUT SWITCH, LOW PRESSURE
0130M00038S	TERMINAL BOARD
B1141643	TRANSFORMER 208/230, 24V (M1, M2, M5, M6, M11, M12, M17, M18)
B1141672	TRANSFORMER 480V, 75VA, RESETTABLE (M3, M4, M7, M8, M13, M14, M19, M20)
0130M00045S	TRANSFORMER 575/24V (M9, M10, M15, M16, M21, M22)

SPECIAL PARTS

IO-354A	INSTALLATION INSTRUCTIONS
RP-480A	REPAIR PARTS MANUAL
B1757910	SUPPLEMENTAL INSERT (EBTDR)

Expanded Model Nomenclature

M1 - CPC036XXX3BXJXBA
M2 - CPC036XXX3BXXBA
M3 - CPC036XXX4BXJXBA
M4 - CPC036XXX4BXXBA
M5 - CPC048XXX3BXJXBA
M6 - CPC048XXX3BXXBA
M7 - CPC048XXX4BXJXBA
M8 - CPC048XXX4BXXBA
M9 - CPC048XXX7BXJXBA
M10 - CPC048XXX7BXXBA
M11 - CPC060XXX3BXJXBA
M12 - CPC060XXX3BXXBA
M13 - CPC060XXX4BXJXBA
M14 - CPC060XXX4BXXBA
M15 - CPC060XXX7BXJXBA
M16 - CPC060XXX7BXXBA
M17 - CPC072XXX3BXJXBA
M18 - CPC072XXX3BXXBA
M19 - CPC072XXX4BXJXBA
M20 - CPC072XXX4BXXBA
M21 - CPC072XXX7BXJXBA
M22 - CPC072XXX7BXXBA

Top Panel/Tubing Assy

Image 1

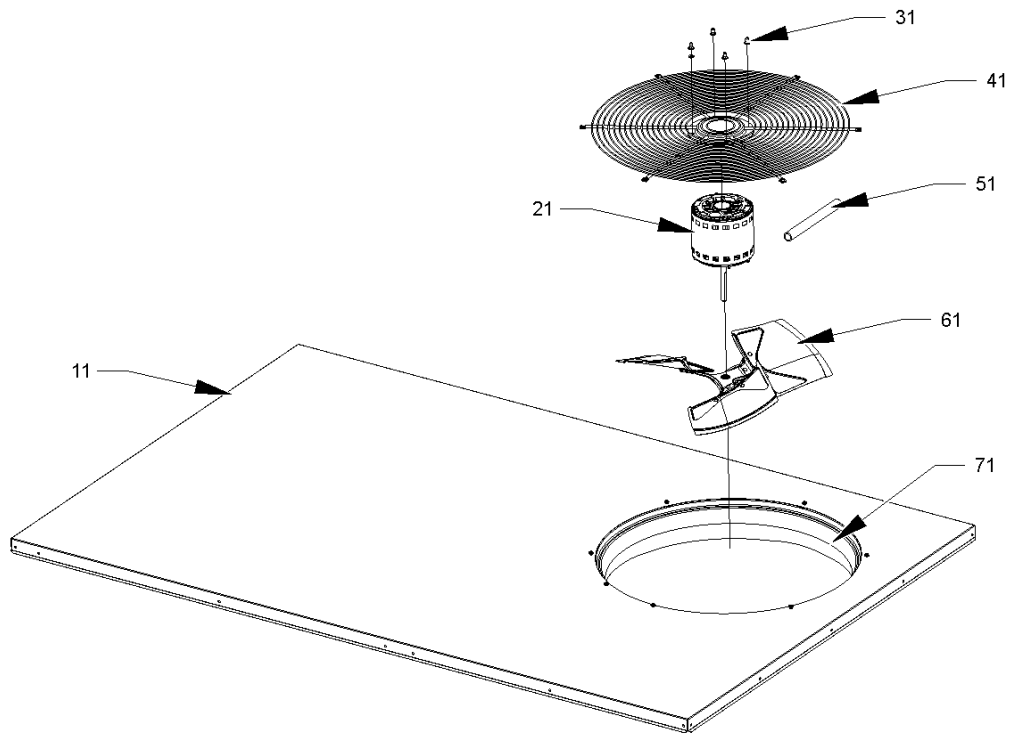
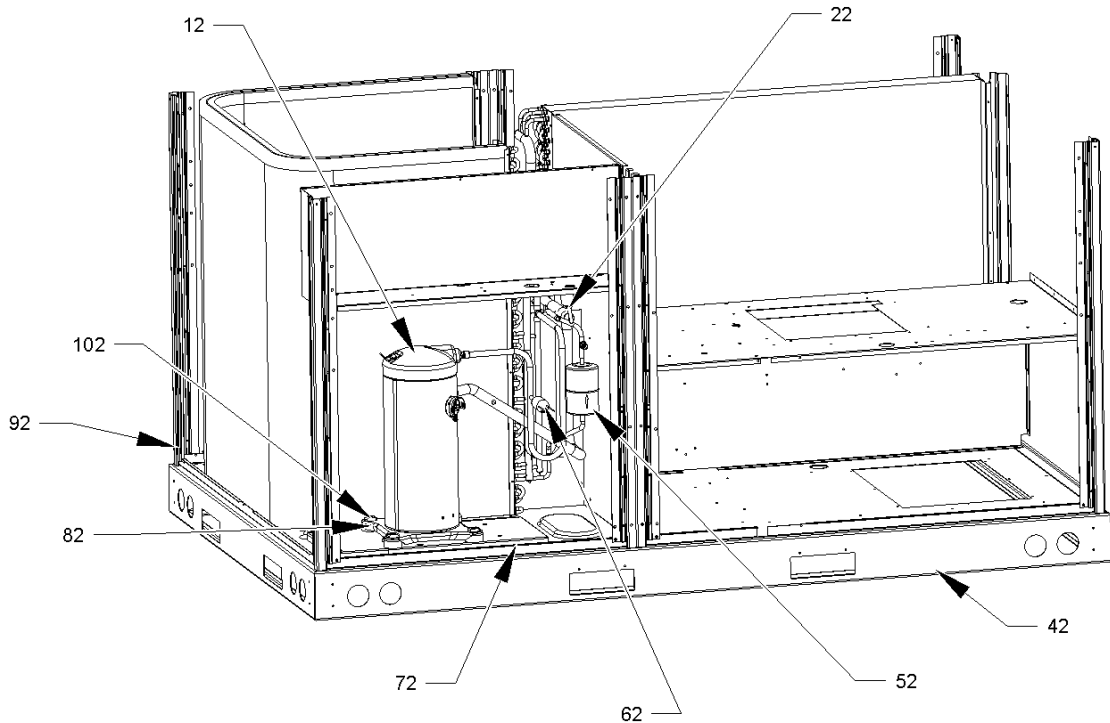

Image 2



Top Panel/Tubing Assy

Ref. Part No: No:	Description:	Ref. Part No: No:	Description:
-------------------	--------------	-------------------	--------------

Image 1:

11	0270L00086S	INSULATED ASSY, TOP PANEL
21	0131M00008PS	COND MOTOR 1/3 HP, 1 SP, 6 PL (M17, M18)
21	B13400249S	COND MOTOR 1/3 HP, 460V (M19, M20)
21	0131M00007PS	COND MOTOR 1/4 HP, 1 SP, 6 PL (M1, M2, M5, M6, M11, M12)
21	B13400269S	COND MOTOR 380/460 50/60 CYCLE (M3, M4, M7, M8, M13, M14)
21	0131M00098S	COND MOTOR 575V (M9, M10, M15, M16)
21	0131M00100S	COND MOTOR 575V (M21, M22)
31	0163M00006P	ACORN NUT 5/16 HEX BLACK (QTY 4)
41	0152G00002S	FAN GRILLE
51	17788000083F	PVC CONDUIT 8.25"
61	0150G00001S	FAN BLADE
71	0161L00000	VENTURI RING 22"

Image 2:

12	ZP31K5ETF5830	COMPRESSOR 31200, 200/230/60/3 (M1, M2)
12	ZP31K5ETFD830	COMPRESSOR 31200, 460/60/3 (M3, M4)
12	ZP39K5ETF5830	COMPRESSOR 39000, 200/230/60/3 (M5, M6)
12	ZP39K5ETFD830	COMPRESSOR 39000, 460/60/3 (M7, M8)
12	ZP39K5ETFE830	COMPRESSOR 39000, 575/60/3 (M9, M10)
12	ZP51K5ETF5830	COMPRESSOR 51000, 208/230/60/3 (M11, M12)
12	ZP51K5ETFD830	COMPRESSOR 51000, 460/60/3 (M13, M14)
12	ZP51K5ETFE830	COMPRESSOR 51000, 575/60/3 (M15, M16)
12	ZP61KCETF5830	COMPRESSOR 61500, 200/230/60/3 (M17, M18)
12	ZP61KCETFD830	COMPRESSOR 61500, 460/60/3 (M19, M20)
12	ZP61KCETFE830	COMPRESSOR 61500, 575/60/3 (M21, M22)
22	0130L00007	CUT-OUT SWITCH, LOW PRESSURE
42	0121L00244RF	SIDE RAIL (QTY 2)
52	20485201	BI-FLOW FILTER DRIER (M17, M18, M19, M20, M21, M22)
52	B5134711	FILTER DRIER (M11, M12, M13, M14, M15, M16)
52	B1219225	SINGLE-FLOW FILTER DRIER, STEEL (M1, M2, M3, M4, M5, M6, M7, M8, M9, M10)
62	0130M00055	CUT-OUT SWITCH, HIGH PRESSURE
72	0121L00310	COMPRESSOR MOUNTING PLATE
82	B1339533	COMPRESSOR GROMMET (QTY 4)
92	0121L00245	END RAIL (QTY 2)
102	M0221641	TF SHOULDER SCREW (QTY 4)
NS	0159L00028	COMPRESSOR SCROLL HARNESS

Expanded Model Nomenclature

M1 - CPC036XXX3BXJXBA
M2 - CPC036XXX3BXXXBA
M3 - CPC036XXX4BXJXBA
M4 - CPC036XXX4BXXXBA
M5 - CPC048XXX3BXJXBA
M6 - CPC048XXX3BXXXBA
M7 - CPC048XXX4BXJXBA
M8 - CPC048XXX4BXXXBA
M9 - CPC048XXX7BXJXBA
M10 - CPC048XXX7BXXXBA
M11 - CPC060XXX3BXJXBA
M12 - CPC060XXX3BXXXBA
M13 - CPC060XXX4BXJXBA
M14 - CPC060XXX4BXXXBA
M15 - CPC060XXX7BXJXBA
M16 - CPC060XXX7BXXXBA
M17 - CPC072XXX3BXJXBA
M18 - CPC072XXX3BXXXBA
M19 - CPC072XXX4BXJXBA
M20 - CPC072XXX4BXXXBA
M21 - CPC072XXX7BXJXBA
M22 - CPC072XXX7BXXXBA

Cabinet Assy

Image 1

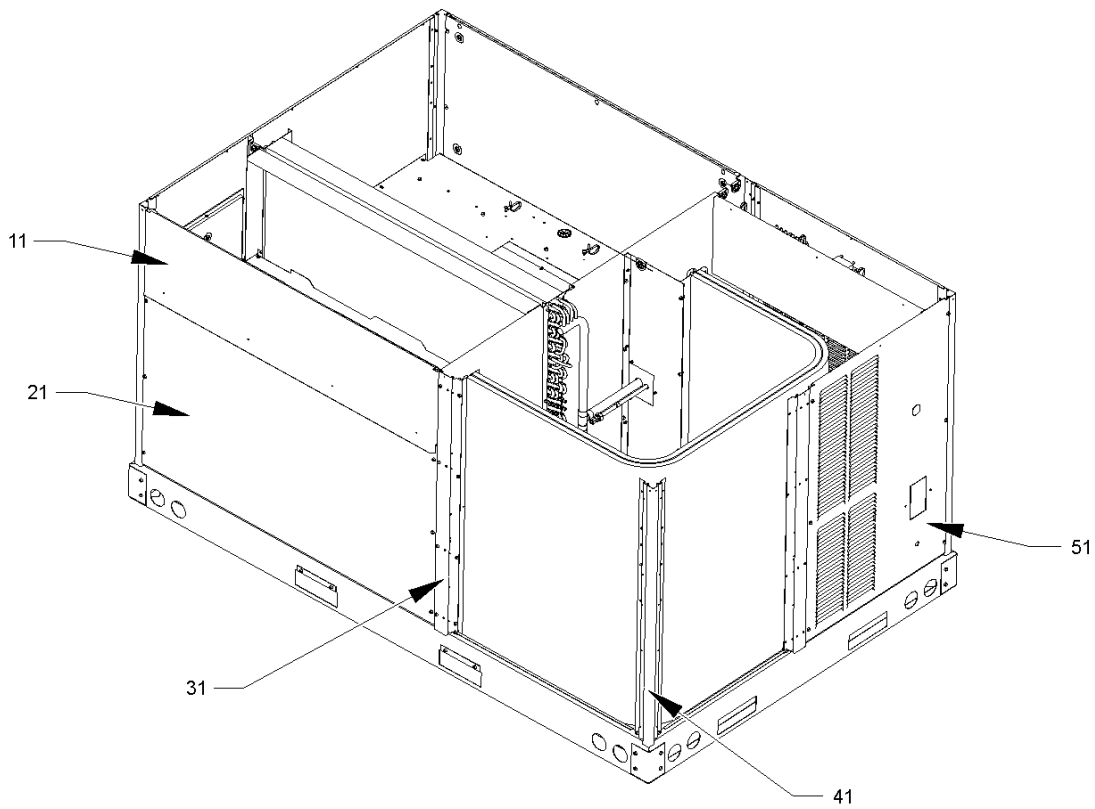
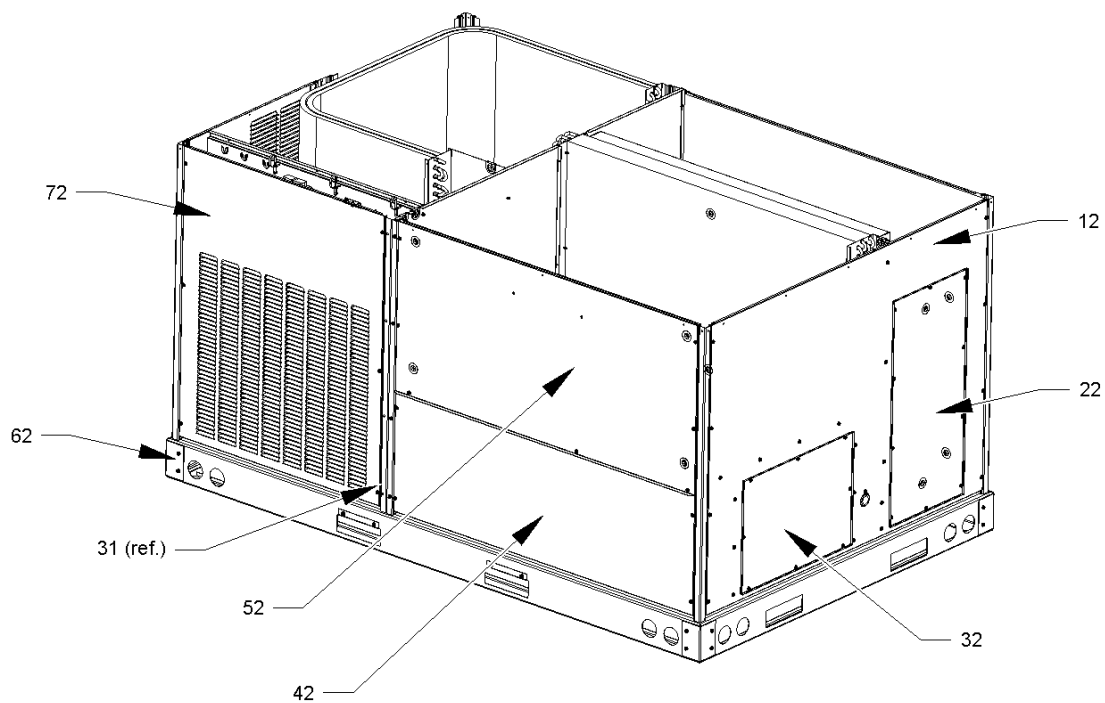

Image 2



Cabinet Assy

**Ref. Part
No: No:**

Description:

**Ref. Part
No: No:**

Description:

Image 1:

11	0270L00080	INSULATED ASSY, FILTER DOOR (M1, M2, M3, M4, M5, M6, M7, M8, M9, M10, M11, M12, M13, M14, M15, M16)
11	0270L00139	INSULATED ASSY, FILTER DOOR (M17, M18, M19, M20, M21, M22)
21	0270L00081	INSULATED ASSY, ECONOMIZER DOOR
31	0121L00233RFDG	POST-SIDE SUPPORT (M1, M2, M3, M4, M5, M6, M7, M8, M9, M10, M11, M12, M13, M14, M15, M16)
31	0121L00343RFDG	POST-SIDE SUPPORT (M17, M18, M19, M20, M21, M22)
41	0121L00237RFDG	CORNER POST (M1, M2, M3, M4, M5, M6, M7, M8, M9, M10, M11, M12, M13, M14, M15, M16)
41	0121L00344RFDG	CORNER POST (M17, M18, M19, M20, M21, M22)
51	0121L00263DG	LOUVERED COMPRESSOR PANEL (M1, M2, M3, M4, M5, M6, M7, M8, M9, M10, M11, M12, M13, M14, M15, M16)
51	0121L00354DG	LOUVERED COMPRESSOR PANEL (M17, M18, M19, M20, M21, M22)
NS	0121L00321	SMOKE DETECTOR COVER

Image 2:

12	0270L00079	INSULATED ASSY, DUCT PANEL (M1, M2, M3, M4, M5, M6, M7, M8, M9, M10, M11, M12, M13, M14, M15, M16)
12	0270L00145	INSULATED ASSY, DUCT PANEL (M17, M18, M19, M20, M21, M22)
22	0270L00011S	INSULATED ASSY, RETURN DUCT
32	0270L00012S	INSULATED ASSY, SUPPLY DUCT
42	0121L00279DG	ELECTRIC HEAT DOOR
52	0270L00084	INSULATED ASSY, BLOWER DOOR (M1, M2, M3, M4, M5, M6, M7, M8, M9, M10, M11, M12, M13, M14, M15, M16)
52	0270L00146	INSULATED ASSY, BLOWER DOOR (M17, M18, M19, M20, M21, M22)
62	0121G00301	RAIL CORNER BRACKET (QTY 4)
72	0121L00262DG	LOUVERED CONTROL PANEL (M1, M2, M3, M4, M5, M6, M7, M8, M9, M10, M11, M12, M13, M14, M15, M16)
72	0121L00353DG	LOUVERED CONTROL PANEL (M17, M18, M19, M20, M21, M22)

Expanded Model Nomenclature

M1 - CPC036XXX3BXJXBA
M2 - CPC036XXX3BXXXBA
M3 - CPC036XXX4BXJXBA
M4 - CPC036XXX4BXXXBA
M5 - CPC048XXX3BXJXBA
M6 - CPC048XXX3BXXXBA
M7 - CPC048XXX4BXJXBA
M8 - CPC048XXX4BXXXBA
M9 - CPC048XXX7BXJXBA
M10 - CPC048XXX7BXXXBA
M11 - CPC060XXX3BXJXBA
M12 - CPC060XXX3BXXXBA
M13 - CPC060XXX4BXJXBA
M14 - CPC060XXX4BXXXBA
M15 - CPC060XXX7BXJXBA
M16 - CPC060XXX7BXXXBA
M17 - CPC072XXX3BXJXBA
M18 - CPC072XXX3BXXXBA
M19 - CPC072XXX4BXJXBA
M20 - CPC072XXX4BXXXBA
M21 - CPC072XXX7BXJXBA
M22 - CPC072XXX7BXXXBA

Partition Assy

Image 1

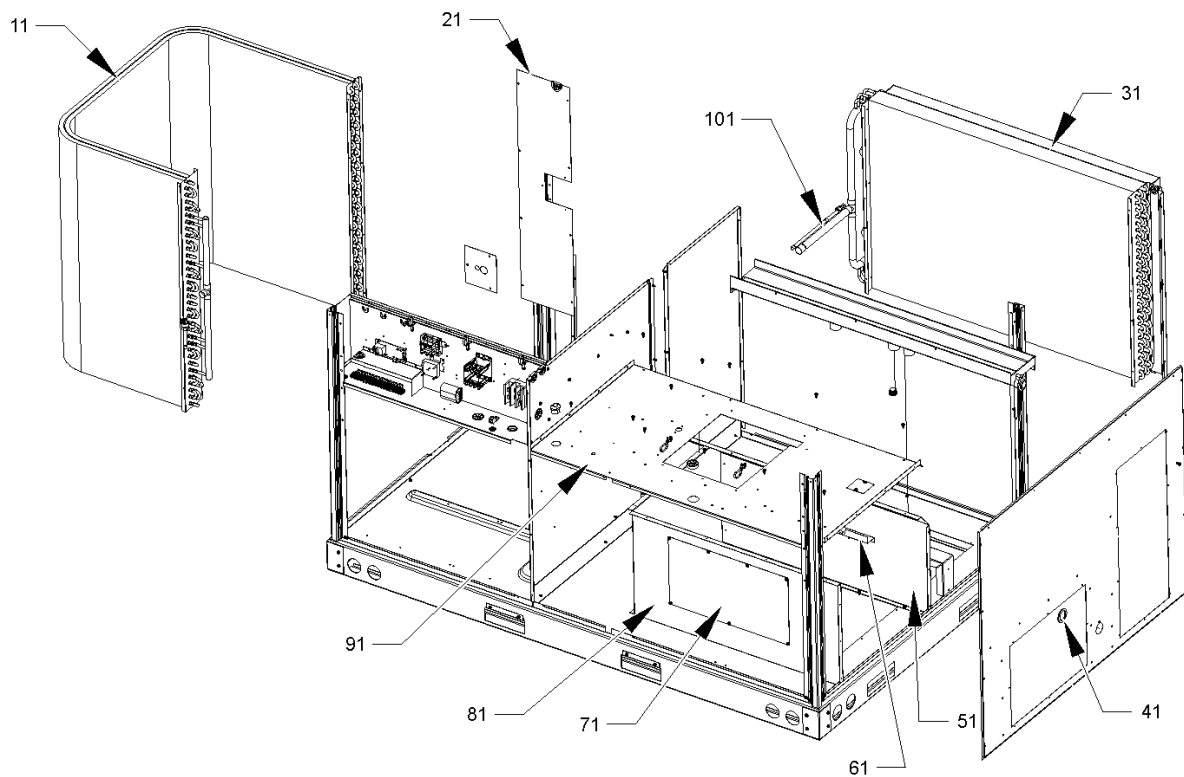
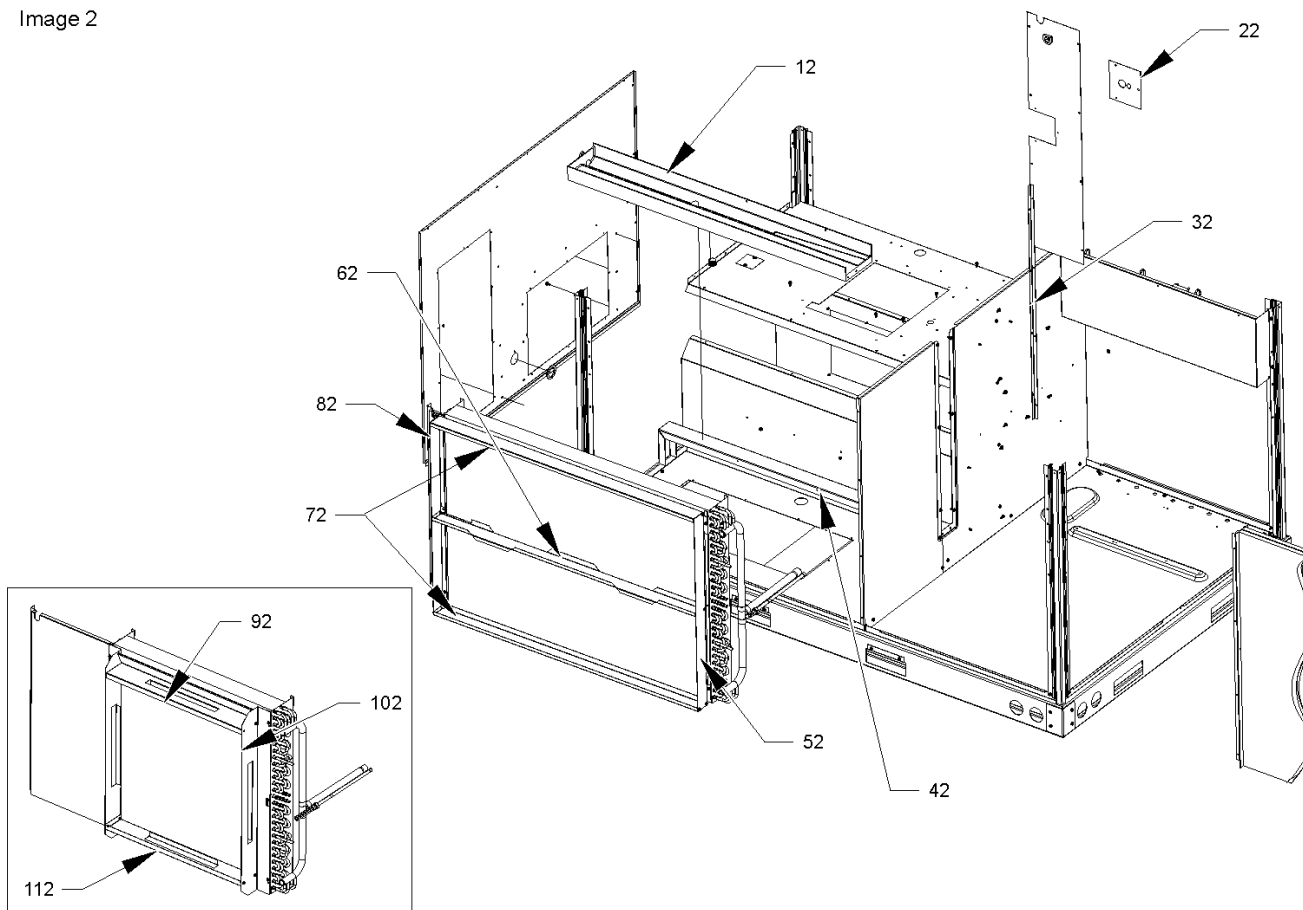

Image 2



Partition Assy

Ref. Part No: No:	Description:	Ref. Part No: No:	Description:		
<i>Image 1:</i>		<i>Image 2:</i>			
11	0201L00034S TUBING ASSY, COND COIL (M12, M14, M16)	NS	0160L00046 FILTER 24 X 24 (M1, M2, M3, M4)		
11	0201L00041S TUBING ASSY, COND COIL (M11, M13, M15)	Expanded Model Nomenclature			
11	0201L00045S TUBING ASSY, COND COIL (M1, M3, M5, M7, M9)	<div style="border: 1px solid black; padding: 5px;"> M1 - CPC036XXX3BXJXBA M2 - CPC036XXX3BXXXBA M3 - CPC036XXX4BXJXBA M4 - CPC036XXX4BXXXBA M5 - CPC048XXX3BXJXBA M6 - CPC048XXX3BXXXBA M7 - CPC048XXX4BXJXBA M8 - CPC048XXX4BXXXBA M9 - CPC048XXX7BXJXBA M10 - CPC048XXX7BXXXBA M11 - CPC060XXX3BXJXBA M12 - CPC060XXX3BXXXBA M13 - CPC060XXX4BXJXBA M14 - CPC060XXX4BXXXBA M15 - CPC060XXX7BXJXBA M16 - CPC060XXX7BXXXBA M17 - CPC072XXX3BXJXBA M18 - CPC072XXX3BXXXBA M19 - CPC072XXX4BXJXBA M20 - CPC072XXX4BXXXBA M21 - CPC072XXX7BXJXBA M22 - CPC072XXX7BXXXBA </div>			
11	0201L00048S TUBING ASSY, COND COIL (M2, M4, M6, M8, M10)				
11	0201L00053 TUBING ASSY, COND COIL (M18, M20, M22)				
11	0201L00055 TUBING ASSY, COND COIL (M17, M19, M21)				
21	0121L00311 COND BLOCK-OFF (M1, M2, M3, M4, M5, M6, M7, M8, M9, M10, M11, M12, M13, M14, M15, M16)				
21	0121L00348 COND BLOCK-OFF (M17, M18, M19, M20, M21, M22)				
31	0202L00020S TUBING ASSY, EVAP COIL (M11, M12, M13, M14, M15, M16)				
31	0202L00024S TUBING ASSY, EVAP COIL (M1, M2, M3, M4)				
31	0202L00029S TUBING ASSY, EVAP COIL (M5, M6, M7, M8, M9, M10)				
31	0202L00032 TUBING ASSY, EVAP COIL (M17, M18, M19, M20, M21, M22)				
41	0154L00009 DRAIN PAN GASKET				
51	0121L00243 DECK SIDE CHANNEL				
61	0121L00288 ELECTRIC HEAT RETAINER				
71	0121L00144 ELECTRIC HEAT COVER				
81	0121L00256 ELECTRIC HEAT PANEL				
91	0121L00242 BLOWER DECK				
<i>Image 2:</i>					
12	0161L00005 DRAIN PAN				
22	0121L00324 COND BLOCK-OFF PLATE				
32	0121L00254 COND MOUNTING ANGLE (M1, M2, M3, M4, M5, M6, M7, M8, M9, M10, M11, M12, M13, M14, M15, M16)				
32	0121L00349 COND MOUNTING ANGLE (M17, M18, M19, M20, M21, M22)				
42	0121L00238 DRAIN PAN SUPPORT				
52	0121L00287 FILTER ANGLE-VERTICAL (RETURN SIDE) (M5, M6, M7, M8, M9, M10, M11, M12, M13, M14, M15, M16)				
52	0121L00357 FILTER ANGLE-VERTICAL (RETURN SIDE) (M17, M18, M19, M20, M21, M22)				
62	0121L00298 FILTER ANGLE-HORIZONTAL (CENTER) (M5, M6, M7, M8, M9, M10, M11, M12, M13, M14, M15, M16, M17, M18, M19, M20, M21, M22)				
72	0121L00286 FILTER ANGLE-HORIZONTAL (M5, M6, M7, M8, M9, M10, M11, M12, M13, M14, M15, M16, M17, M18, M19, M20, M21, M22)				
82	0121L00303 FILTER ANGLE-VERTICAL (HAIRPIN SIDE)				
82	0121L00358 FILTER ANGLE-VERTICAL (HAIRPIN SIDE)				
92	0121L00290 FILTER ANGLE-TOP (M1, M2, M3, M4)				
102	0121L00292 FILTER ANGLE-VERTICAL (M1, M2, M3, M4)				
112	0121L00291 FILTER ANGLE-BOTTOM (M1, M2, M3, M4)				
NS	B1369608 AIR FILTER 20 X 16 X 2 (M17, M18, M19, M20, M21, M22)				
NS	0160L00008 FILTER 14 X 20 X 2 (M5, M6, M7, M8, M9, M10, M11, M12, M13, M14, M15, M16)				

Belt Drive Assy

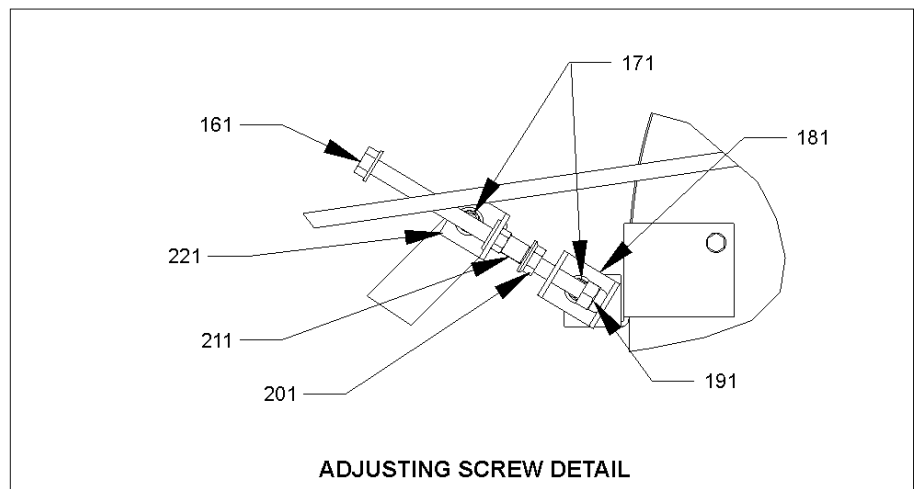
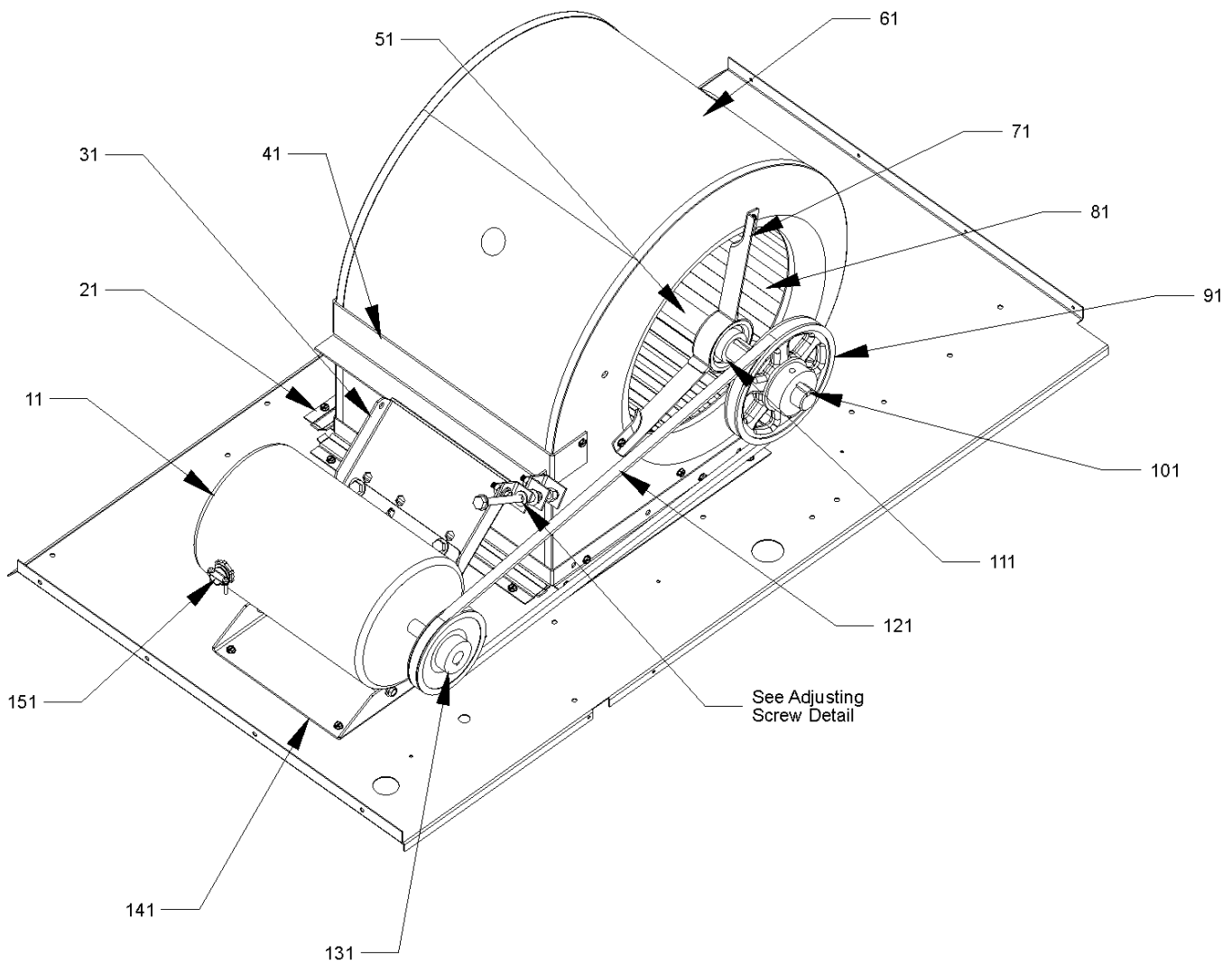

Belt Drive Assy

Ref. Part No:	No:	Description:	Ref. Part No:	No:	Description:
<i>Image 1:</i>			Expanded Model Nomenclature		
11	B3240007	BELT DRIVE MOTOR (230/460)/60/3P (M17, M18, M19, M20)	M1 -	CPC036XXX3BXJXBA	
11	0131L00003S	BELT DRIVE MOTOR 1 HP (M1, M2, M3, M4, M5, M6, M7, M8, M11, M12, M13, M14)	M2 -	CPC036XXX3BXXXBA	
11	0131L00004S	BELT DRIVE MOTOR 1.5 HP 575V (M9, M10, M15, M16, M21, M22)	M3 -	CPC036XXX4BXJXBA	
21	0121L00297	BLOWER SIDE ANGLE (QTY 3)	M4 -	CPC036XXX4BXXXBA	
31	0121L00271	MOTOR MOUNT PLATE	M5 -	CPC048XXX3BXJXBA	
41	0121L00272	MOTOR MOUNT ANGLE	M6 -	CPC048XXX3BXXXBA	
51	0163L00005	BELT DRIVE BLOWER SHAFT	M7 -	CPC048XXX4BXJXBA	
61	2539302FS	BLOWER HOUSING 11 X 10	M8 -	CPC048XXX4BXXXBA	
71	B3201300	MOUNTING BRACKET BEARING (QTY 2)	M9 -	CPC048XXX7BXJXBA	
81	B1368056	BELT DRIVE BLOWER WHEEL	M10 -	CPC048XXX7BXXXBA	
91	B2120011	FIXED SHEAVE (M1, M2, M3, M4)	M11 -	CPC060XXX3BXJXBA	
91	0163L00031	FIXED SHEAVE AK59 (M17, M18, M19, M20, M21, M22)	M12 -	CPC060XXX3BXXXBA	
91	B3204303	FIXED SHEAVE AK61 (M11, M12, M13, M14, M15, M16)	M13 -	CPC060XXX4BXJXBA	
91	B3204310	FIXED SHEAVE AK66 (M5, M6, M7, M8, M9, M10)	M14 -	CPC060XXX4BXXXBA	
101	B1398604	STEEL KEY (000158812) 2.0"	M15 -	CPC060XXX7BXJXBA	
111	B1399500	BALL BEARING 1.00" (QTY 2)	M16 -	CPC060XXX7BXXXBA	
121	0164L00003	FAN BELT, NOTCHED	M17 -	CPC072XXX3BXJXBA	
131	0163L00024	VARIABLE PITCH SHEAVE 1VL40 X 5/8" (M1, M2, M3, M4)	M18 -	CPC072XXX3BXXXBA	
131	B2120001	VARIABLE PITCH SHEAVE 1VL44 X 3/8" (M5, M6, M7, M8, M9, M10, M11, M12, M13, M14, M15, M16)	M19 -	CPC072XXX4BXJXBA	
131	B2120014	VARIABLE PITCH SHEAVE 1VL44 X 7/8" (M17, M18, M19, M20, M21, M22)	M20 -	CPC072XXX4BXXXBA	
141	0121L00273	MOTOR PIVOT ANGLE	M21 -	CPC072XXX7BXJXBA	
151	B1393726	ELECT. CONNECTING BUSHING	M22 -	CPC072XXX7BXXXBA	
161	0163M00054	BOLT			
171	B1393738	BOLT 1/4-20 X 3/4" (QTY 4)			
181	0121L00274	MOTOR ADJUST BRACKET			
191	0163M00055	ACORN NUT 5/16 X 18			
201	B1393020	FLANGED LOCKNUT 5/16-18TPI			
211	B1393027	HEX NUT INSERT 5/16-18 (QTY 5)			
221	0121L00275	MOUNTING BRACKET INSERT			
NS	1864700F	BELT DRIVE BLOWER CUT-OFF			
NS	B1398603	STEEL KEY (000158812) 4.5"			

Control Box Assy

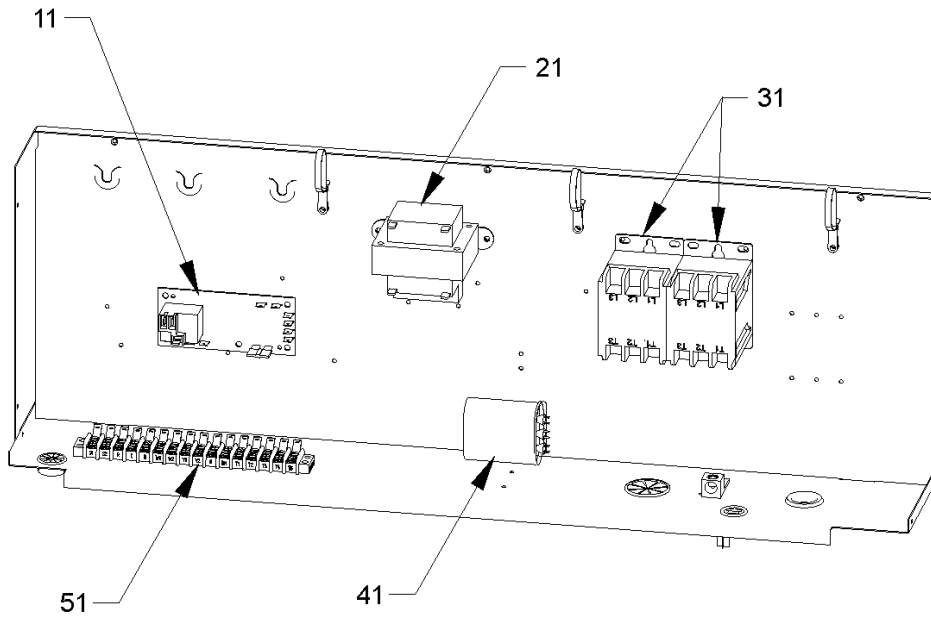

Control Box Assy

Ref. Part No:	Ref. Part No:	Description:	Description:
---------------	---------------	--------------	--------------

Image 1:

11	PCBFM103S	BOARD, ELECTRONIC BLOWER TIME DELAY RELAY
21	CONT3P025024VS	CONTACTOR 25 AMP, 3P, 24V (M3, M4, M7, M8, M9, M10, M13, M14, M15, M16, M19, M20, M21, M22)
21	CONT3P030024VS	CONTACTOR 30 AMP, 3P, 24V (M1, M2, M5, M6, M11, M12, M17, M18)
31	B1141643	TRANSFORMER 208/230, 24V (M1, M2, M5, M6, M11, M12, M17, M18)
31	B1141672	TRANSFORMER 480V, 75VA, RESETTABLE (M3, M4, M7, M8, M13, M14, M19, M20)
31	0130M00045S	TRANSFORMER 575/24V (M9, M10, M15, M16, M21, M22)
41	CAP050000370VAS	CAPACITOR 5/370V
51	0130M00038S	TERMINAL BOARD
NS	20520901	CAPACITOR STRAP
NS	0259L00054	WIRING HARNESS (M1, M2, M5, M6, M9, M10, M11, M12, M15, M16, M17, M18, M21, M22)
NS	0259L00057	WIRING HARNESS
NS	0259L00060	WIRING HARNESS (M3, M4, M7, M8, M13, M14, M19, M20)
NS	0259L00061	WIRING HARNESS
NS	0259L00064	WIRING HARNESS
NS	0259L00065	WIRING HARNESS (M1, M2, M3, M4, M5, M6, M7, M8, M9, M10, M11, M12, M13, M14, M15, M16)
NS	0259L00094	WIRING HARNESS (M17, M18, M19, M20, M21, M22)

Expanded Model Nomenclature

M1 - CPC036XXX3BXJXBA
M2 - CPC036XXX3BXXXBA
M3 - CPC036XXX4BXJXBA
M4 - CPC036XXX4BXXXBA
M5 - CPC048XXX3BXJXBA
M6 - CPC048XXX3BXXXBA
M7 - CPC048XXX4BXJXBA
M8 - CPC048XXX4BXXXBA
M9 - CPC048XXX7BXJXBA
M10 - CPC048XXX7BXXXBA
M11 - CPC060XXX3BXJXBA
M12 - CPC060XXX3BXXXBA
M13 - CPC060XXX4BXJXBA
M14 - CPC060XXX4BXXXBA
M15 - CPC060XXX7BXJXBA
M16 - CPC060XXX7BXXXBA
M17 - CPC072XXX3BXJXBA
M18 - CPC072XXX3BXXXBA
M19 - CPC072XXX4BXJXBA
M20 - CPC072XXX4BXXXBA
M21 - CPC072XXX7BXJXBA
M22 - CPC072XXX7BXXXBA



Free Manuals Download Website

<http://myh66.com>

<http://usermanuals.us>

<http://www.somanuals.com>

<http://www.4manuals.cc>

<http://www.manual-lib.com>

<http://www.404manual.com>

<http://www.luxmanual.com>

<http://aubethermostatmanual.com>

Golf course search by state

<http://golfingnear.com>

Email search by domain

<http://emailbydomain.com>

Auto manuals search

<http://auto.somanuals.com>

TV manuals search

<http://tv.somanuals.com>