



**DESCRIPTION AND APPLICATION**

The Model 625TRSKK is a noise cancelling handset microphone, designed for high articulation speech transmission under high ambient noise conditions. The model 625TRSKK is the result of continuous study of the needs of the communications industry and it uniquely meets the specialized requirements of airline, two-way radio and industrial applications. This handset employs a transistorized pressure gradient microphone utilizing two sound entrances for reduction of interfering ambient noise. Stated simply, if sound pressure and phase are reasonably identical at both sound entrances, cancellation occurs. If, however, the sound originates in close proximity to one sound entrance (i.e. 1/4 or 1/2 inch) and more distant to the other sound entrance, then a pressure and phase differential will exist and little cancellation will occur. The 625TRSKK is unexcelled at discriminating between near and distant sounds for maximum ambient noise rejection. The compact two-stage transistor amplifier is specially stabilized and will operate uniformly from +140°F. down to freezing temperatures. Output of the transistor amplifier is designed to wire directly into inputs designed for carbon microphones. The 625TRSKK provides extremely reliable, crisp, clear speech reproduction with high sensitivity and low distortion.

**SPECIFICATIONS**

**Polar Pattern:** Bidirectional pressure gradient (differential close-talking)  
**Output Level:** -48 db  
 (0 db = 1 volt/dyne/cm<sup>2</sup>)  
**Impedance:** Microphone: 150 ohms  
 Receiver: 150 ohms

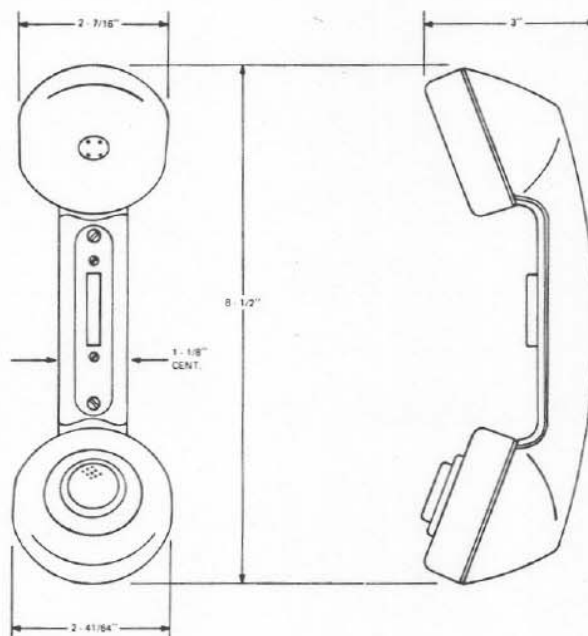

Figure 1 - Dimensions

**Diaphragm:** Electro-Voice Acoustalloy<sup>®</sup>  
**Case Material:** High impact phenolic  
**Finish:** Black  
**Amplifier Gain:** 35 db  
 (when supply voltage is 6 volts)  
**Current Drain:** 22 ma at 14 volts  
**Rated Supply Voltage:** 6-20 v d.c.  
**Maximum Output:** 5% distortion. Not less than 0.7 v r.m.s. (6 volt supply) 2.0 v (20 volt supply)  
**Dimensions:** 8-1/2" L x 2-41/64" W x 3" H  
**Net Weight:** 1 lbs., 6 oz.  
**Cable:** 5-conductor coiled cord, 5' extended  
**Connector:** None supplied  
**Switch:** Press to talk (non-shorting type) and relay switch  
**Temperature Range:** Freezing to +140°F.  
**FAA Type Certificate:** TC 3R42-2

MODEL 625TRSKK HANDSET MICROPHONE

## OVERHAUL INSTRUCTIONS

1. **Special Tools:** None
2. **Disassembly:** ( See Figure 4 )
  - a. Remove microphone cap, lift out housing.
  - b. Do not remove the head subassembly unless it is necessary to replace the head. If it is necessary to replace this component, proceed as indicated in step c.
  - c. Unsolder black leads at head. Head can now be pulled out the bottom of the housing.
3. **Cleaning:**
  - a. Thoroughly clean all dust and dirt from microphone by first using dry, compressed air to dislodge dirt from inaccessible corners. Then clean each part with a lint-free cloth or brush, slightly dampened with dry cleaning solvent, Federal Specification P-S-661. **Do not get solvent on head diaphragm.**
4. **Inspection:**
  - a. Examine unit for damaged or dried-out wiring or sleeving. Check all soldering connections for good contacts.
  - b. Check cable for signs of damage such as cuts or cracks.
5. **Repair and Replacement:**
  - a. Replace any part which is damaged.
  - b. Check resistance across the head with an ohmmeter. It should be about 10 ohms. In addition, a distinct click from the microphone element should be heard when the circuit to the ohmmeter is made or interrupted. If it is not, replace head as described in the reassembly procedure.
6. **Reassembly:**
  - a. Reassembly is the reverse of disassembly. Dampingslot in head must line up with slot in housing.
7. **Test Procedure:** ( See Figure 3 )
8. **Check of Switch Operation:** Check the operation of the switch as follows:
  - a. With the switch released, check the resistance between the blue and green leads. It should be infinite.
  - b. Check the resistance between the white and black leads. It should be infinite.
  - c. Depress switch and check resistance between blue and green leads. It should be zero.

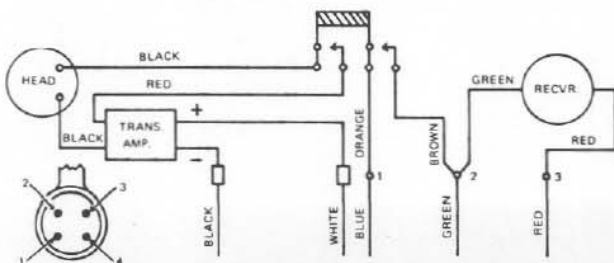

Figure 2 - Wiring Diagram

- d. Check resistance between red and green leads, it should read approximately 30 ohms.
  - e. Depress switch and check resistance between white and black leads. It should be approximately 1000 ohms.
9. **Check of Microphone Output:** The best procedure for testing the microphone is to compare its output with one known to be operating properly, using the test set-up as shown in Figure 3.
- Check the output voltage as follows:
- a. Depress microphone switch and adjust rheostat to obtain 12 to 14 volts on a DC meter.
  - b. Hold the test microphone about ¼ inch from the mouth and talk at normal speech level with microphone switch depressed. An output of about 0.031 volt should be obtained.

### WARRANTY

Electro-Voice aircraft microphones and accessories are guaranteed for 18 months from date of original purchase against malfunction due to defects in workmanship and materials. If such malfunction occurs, microphone will be repaired or replaced (at our option) without charge for materials or labor if delivered prepaid to the proper Electro-Voice service facility. Unit will be returned prepaid. Warranty does not cover finish, appearance items, cables, cable connectors, or switches and does not cover malfunction due to abuse or operation at other than specified conditions. Repair by other than Electro-Voice or its authorized service agencies will void this guarantee.

For correct shipping address, instructions on return of Electro-Voice products for repair, and locations of authorized service agencies, please write: Service Department, Electro-Voice, Inc., 600 Cecil Street, Buchanan, Michigan 49107 (Phone 616/695-6831).

Electro-Voice also maintains complete facilities for non-warranty service of E-V products.

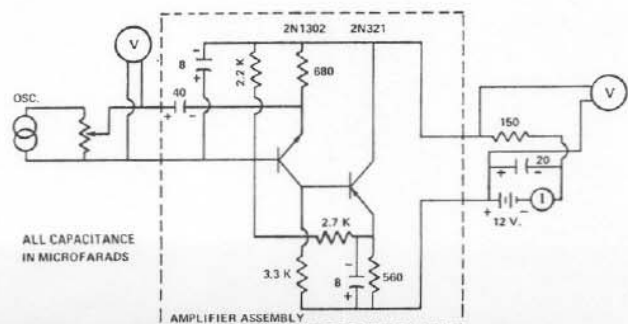

Figure 3 - Test Setup

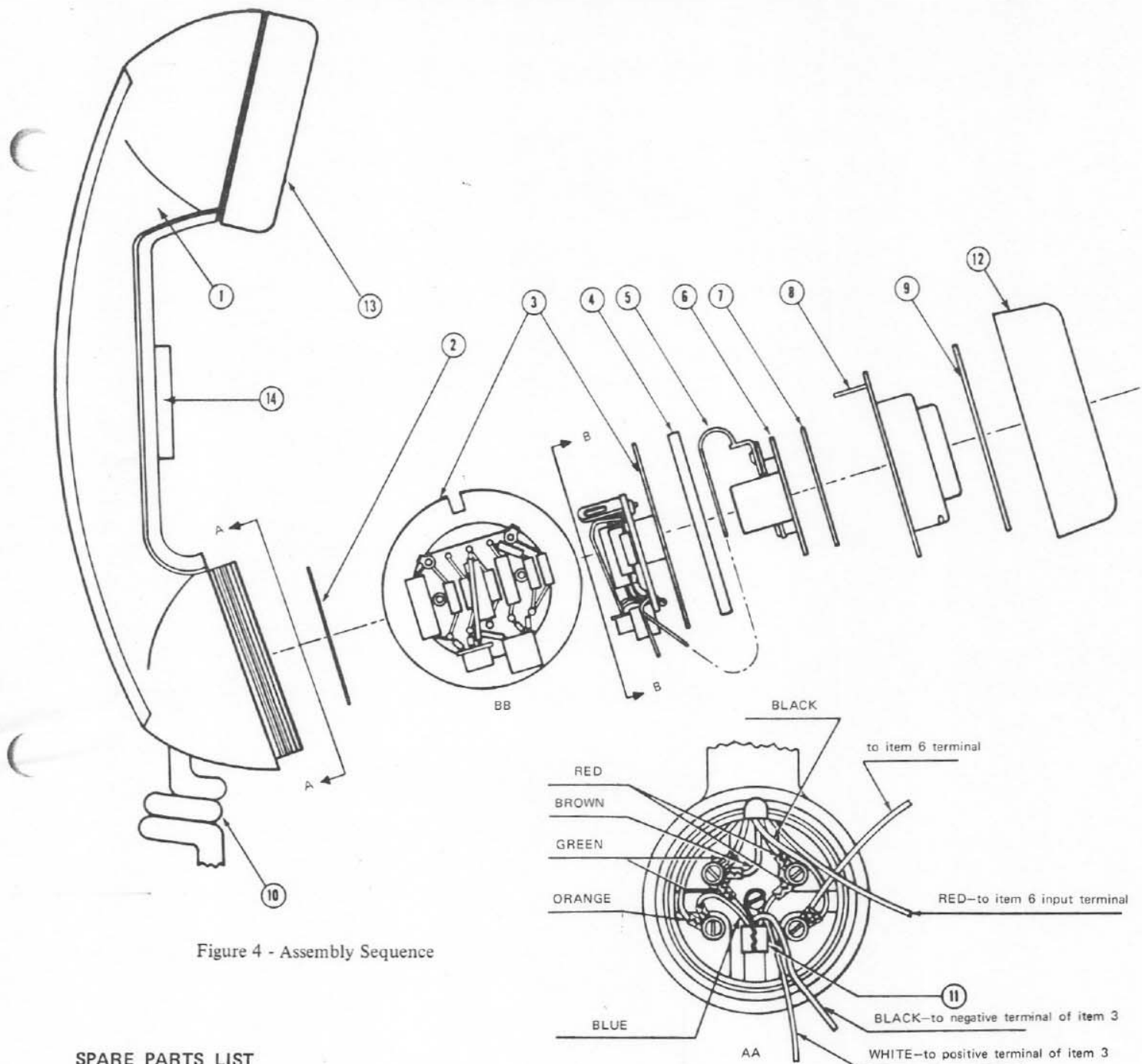
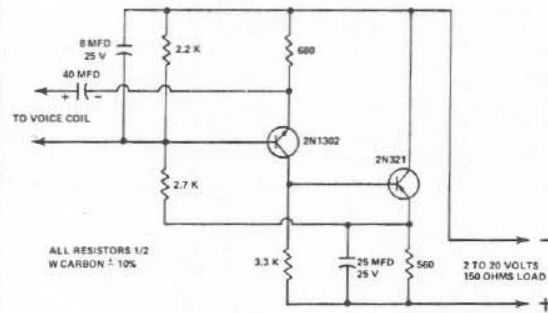

Figure 4 - Assembly Sequence

SPARE PARTS LIST

ITEM	PART NUMBER	DESCRIPTION
1	A72271	Handset, SC model 26, w/switch & receiver
2	72968	Insulator Disk, Paper
3	8227	Transistor Amp. Subassembly
4	4051	Gasket, Rubber
5	1608	Wire, Hookup, black # 22, 4" long
6	C8009	Head Subassembly
7	3863	Washer, Paper
8	82688	Housing Subassembly
9	4052	Gasket, Paper
10	8080	Cable Subassembly
11	20203	Clamp, cord
12	73069	Mouthpiece
13	73068	Ear Cap
14	5696	Switch



Schematic - Transistor Amplifier

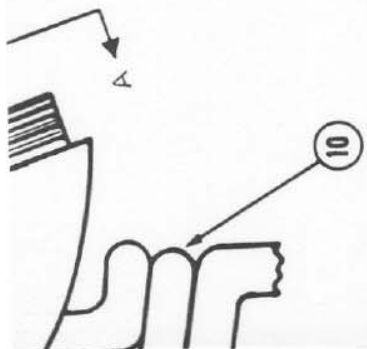
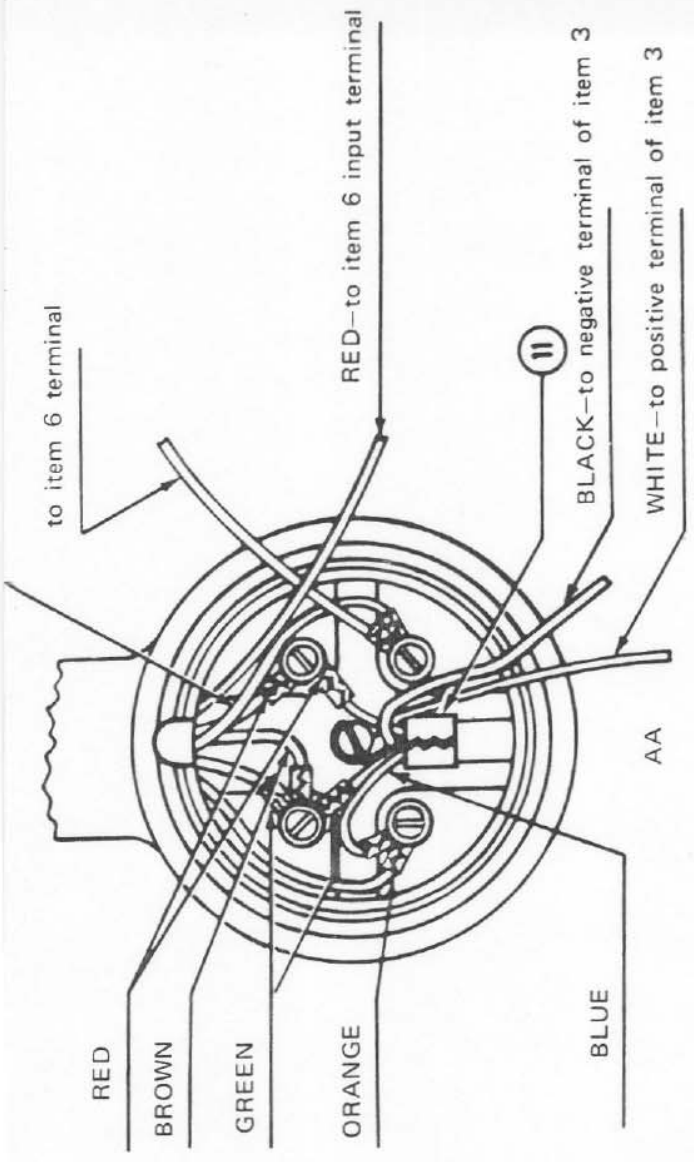
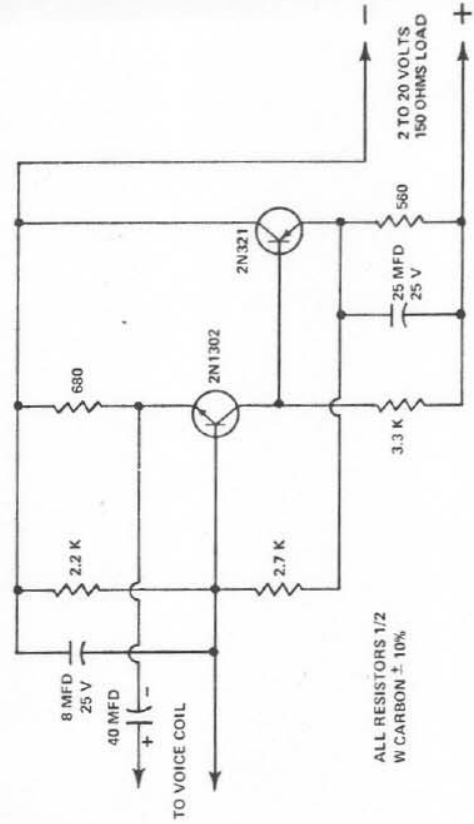

Figure 4 - Assembly Sequence



**PARTS LIST**

PART NUMBER	DESCRIPTION
A72271	Handset, SC model 26, w/switch & receiver
72968	Insulator Disk, Paper
8227	Transistor Amp. Subassembly
4051	Gasket, Rubber
1608	Wire, Hookup, black #22, 4" long
C8009	Head Subassembly
3863	Washer, Paper
82688	Housing Subassembly
4052	Gasket, Paper
8080	Cable Subassembly
20203	Clamp, cord
73069	Mouthpiece
73068	Ear Cap
5696	Switch



Schematic - Transistor Amplifier

head as described in the reassembly procedure.

**6. Reassembly:**

- a. Reassembly is the reverse of disassembly. Damping slot in head must line up with slot in housing.

**7. Test Procedure:** (See Figure 3)

**8. Check of Switch Operation:** Check the operation of the switch as follows:

- a. With the switch released, check the resistance between the blue and green leads. It should be infinite.
- b. Check the resistance between the white and black leads. It should be infinite.
- c. Depress switch and check resistance between blue and green leads. It should be zero.

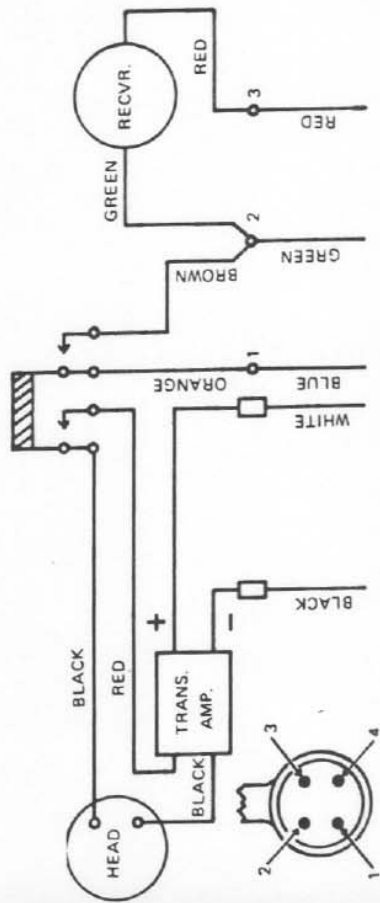

Figure 2 - Wiring Diagram

For correct shipping address, instructions on return of Electro-Voice products for repair, and locations of authorized service agencies, please write: Service Department, Electro-Voice, Inc., 600 Cecil Street, Buchanan, Michigan 49107 (Phone 616/695-6831).

Electro-Voice also maintains complete facilities for non-warranty service of E-V products.

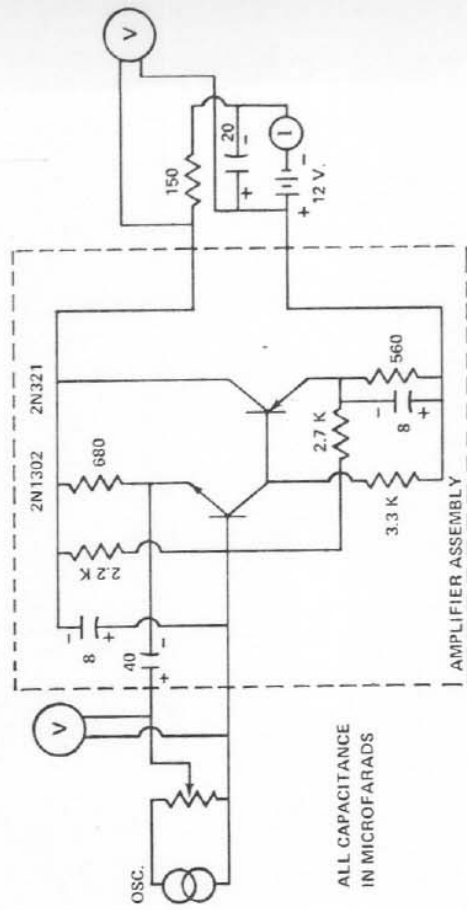

Figure 3 - Test Setup

## Free Manuals Download Website

<http://myh66.com>

<http://usermanuals.us>

<http://www.somanuals.com>

<http://www.4manuals.cc>

<http://www.manual-lib.com>

<http://www.404manual.com>

<http://www.luxmanual.com>

<http://aubethermostatmanual.com>

Golf course search by state

<http://golfingnear.com>

Email search by domain

<http://emailbydomain.com>

Auto manuals search

<http://auto.somanuals.com>

TV manuals search

<http://tv.somanuals.com>