

TO: ~~XXXXXXXXXX~~

NEW

REVISED

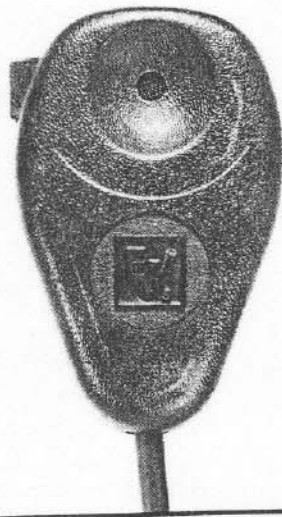

# Aviation Model 903E Microphone, Electret Noise Cancelling

## SPECIFICATIONS (Per RTCA/DO-170)

**Generating Element:**  
Electret Condenser

**Frequency Response:**  
300-5,000 Hz - see Figure 1

**Polar Pattern:**  
Pressure gradient  
(differential close-talking)

**Impedance:**  
Matches standard aircraft  
carbon circuitry

**Sensitivity:**  
400 mV  $\pm$  3 dB for  
114 dB re 20 $\mu$  pascals  
(normal speech)  
(output of built-in amplifier)

**Power Requirements:**  
See test circuit Figure 3  
(operates into carbon microphone circuit)

**Current Drain:**  
11 ma at 8 V dc (12-volt system)  
27 ma at 16 V dc (24-volt system)

**Case Material:**  
Black ABS

**Dimensions:**  
91.5 mm (3.6 in.) length, less hanger  
61.0 mm (2.4 in.) width  
35.6 mm (1.4 in.) depth

**Weight:**  
180 grams

**Accessories Supplied:**  
Panel mounting bracket (8474)

**Certification:**  
FAA TSO C-58a

## DESCRIPTION

The Electro-Voice model 903E condenser handheld microphone is designed for use in high noise environments where high speech intelligibility is desired such as in aircraft cockpits, passenger cabins, control towers or terminal areas.

The electret element virtually eliminates EMI, RFI, and magnetic signals channeling the full power of your communications system into crisp, articulate voice transmission with the RTCA frequency response.

The microphone is recommended for advanced technology air transports employing electronic flight instrumentation systems (glass cockpits). Its proven electret technology will not decay or deteriorate in any way over extended periods.

## Features:

- Highly reliable
- EMI and RFI protected
- Tailored voice response for high articulation per RTCA/DO-170
- Immune to aircraft generated magnetic fields
- Greater durability
- Lightweight
- 903-1341 (with PJ-068 connector)
- 903-1342 (with A4M connector)

## WARRANTY (Limited)

Electro-Voice Aircraft Microphones are guaranteed for a period of thirty-six months from date of original purchase against malfunction due to defects in workmanship and materials. If such malfunction occurs, microphone will be repaired or replaced (at our option) without charge for materials or labor if delivered prepaid to the proper Electro-Voice service facility. Unit will be returned prepaid. Warranty does not extend to finish, appearance items, cables, cable connectors, switches or malfunction due to abuse or operation under other than specified conditions, nor does it extend to incidental or consequential damages. Some states do not allow the exclusion or limitation of incidental or consequential damages, so the above exclusion may not apply to you. Repair by other than Electro-Voice or its authorized service agencies will void this guarantee. This warranty gives you specific legal rights, and you may also have other rights which vary from state to state.

Service and repair address for this product:  
Electro-Voice, Inc., 600 Cecil Street,  
Buchanan, Michigan 49107.

Specifications subject to change  
without notice.

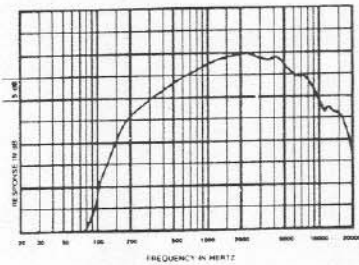

**FIGURE 1**  
Frequency Response

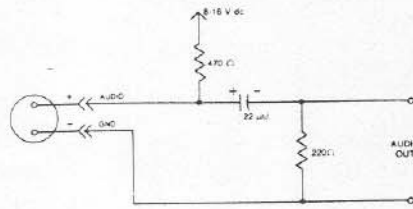

**FIGURE 2**  
Test Circuit  
Per RTCA/DO-170

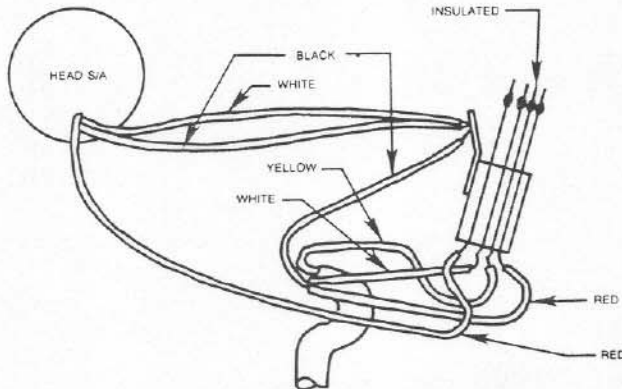

**FIGURE 3**  
Wiring Diagram  
903-1341, 1342

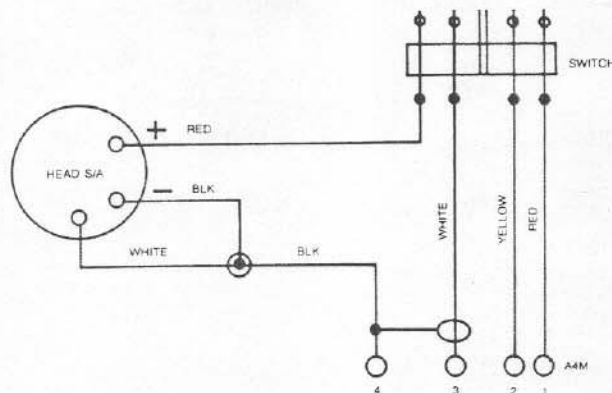

**FIGURE 4**  
903-1342 Schematic

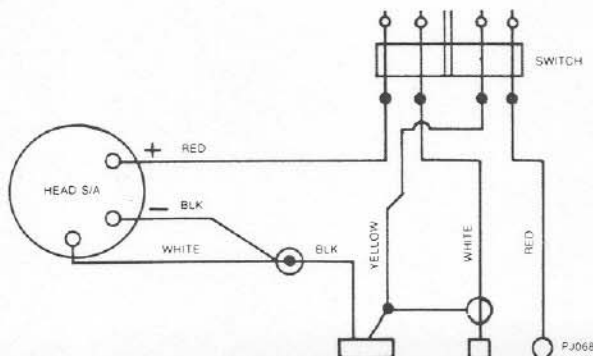

**FIGURE 5**  
903-1341 Schematic

## REPAIR INSTRUCTIONS

1. **Special Tools:** None.
2. **Disassembly:** (See Figure 5)
  - a. Remove 4 rear screws, holding front and rear case halves together.
  - b. Mic head assembly will slip out of front case.
  - c. Switch plate has to be removed if cable S/A is to be removed.
3. **Inspection:**
  - a. Inspect switch contacts for signs of excessive wear.
  - b. Examine unit for damaged or dried-out wiring or sleeving. Check all solder connections for good contacts.
  - c. Check cable for signs of damage such as cuts or cracks.
4. **Repair and Replacement:**
  - a. Replace any part which is damaged.
  - b. The mic head assembly is sealed and not repairable—replace entire assembly (EV#81393) if defective.
5. **Reassembly:** Reverse Step 2 above.
6. **Check of Microphone Output:**  
The electret microphone has the carbon equivalent circuit inside the head assembly. A speech output of approximately 0.2 volts should be obtained when used with the DO-170 test circuit or an aircraft intercom.
7. **Performance to Specifications:**
  - a. Electrical conformance to DO-170 requires special equipment and an artificial voice.
  - b. Certification can only be given by the Electro-Voice Service Center in Buchanan, Michigan.
  - c. If proof of performance and/or certification is required, send the unit to the warranty address on Page 1.

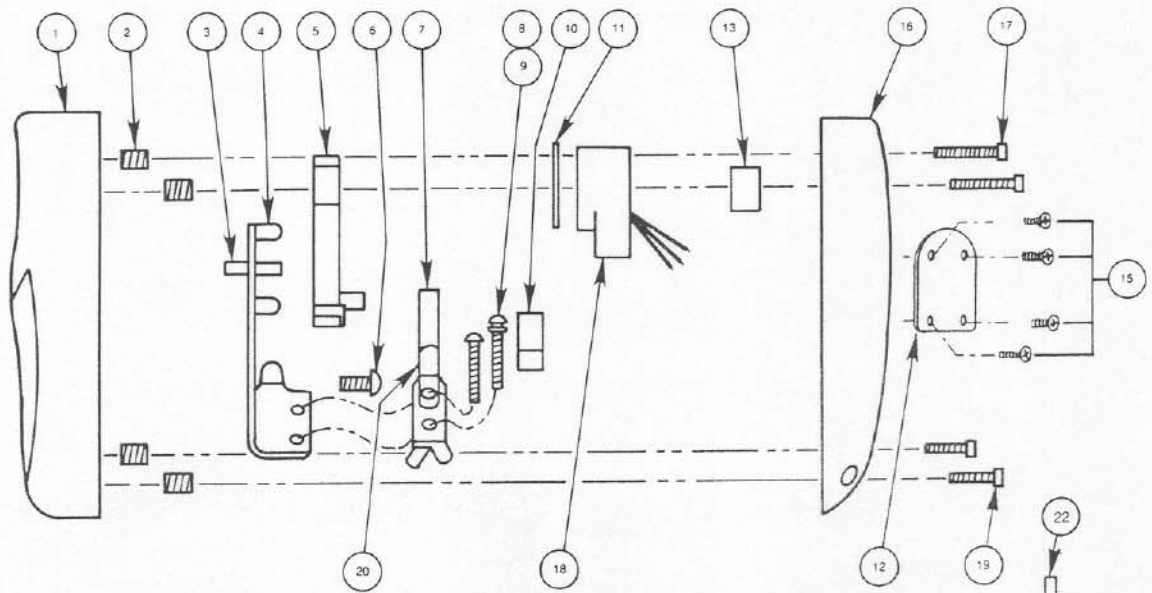
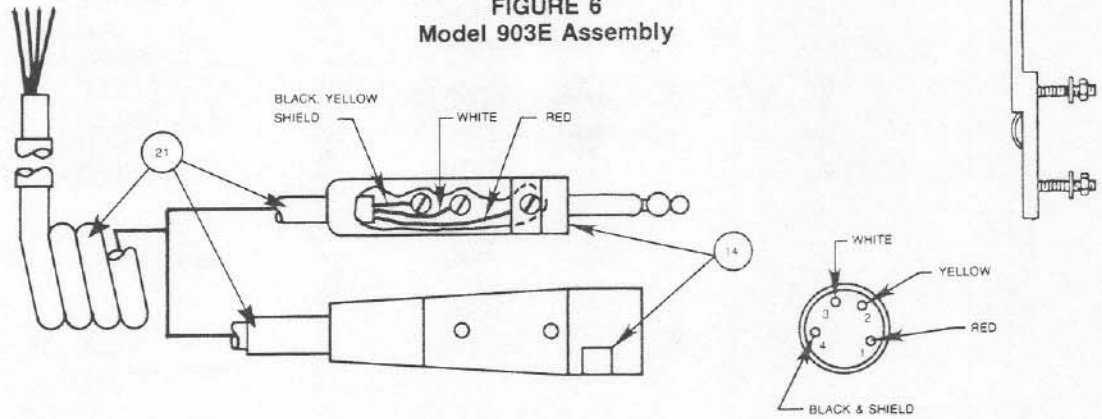

FIGURE 6  
Model 903E Assembly



ITEM	PART NO.	REQ'D.	DESCRIPTION
1	A72319-RL	1	Front Case
2	75241	4	Insert
3	75993-AY	1	Pivot Pin
4	75992-AY	1	Switch Plate
5	75991-RL	1	Actuator
6	62607-AD	1	Screw, Pan Head, Phillips
7	56065	1	Leaf Switch
8	L60126-AP	2	Screw, Binding Head, Phillips
9	4067-AD	1	Lock Washer
10	19048-AD	1	Spring
11	38283	1	Rubber Gasket
12	48875	1	Nameplate
13	A72318	1	Foam Spacer
14	X48559	1	Nameplate (903-1342)
	W48559	1	Nameplate (903-1341)
15	C60024-AD	4	Screws, #2
16	72570-RL	1	Case Back
17	62608	2	Screw, Filled Head, Slotted
18	81393	1	Microphone S/A
19	62609	2	Screw, Filled Head, Slotted
20	27057	1	Lug
21	81489	1	Cable S/A with A4M (903-1342)
	81488	1	Cable S/A with PJ-068 (903-1341)
22	8474	1	Mounting Bracket

## ENVIRONMENTAL QUALIFICATION FORM

MICROPHONE, ELECTRET, (HANDHELD 903E & 913E), (BOOM MOUNTED 978E)  
 MODELS: 978E, 903E & 913E TSO NUMBER: TSO-C58a

### Specifications Enclosed with Microphones

CONDITIONS	DO-160B PARAGRAPH #	DESCRIPTION OF CONDUCTED TESTS
Temperature and Altitude	4.0 Rev. 1	Equipment tested to Category B1
Low Temperature	4.5.1	
High Temperature	4.5.2, 4.5.3	
Altitude	4.6.1	
Decompression	4.6.2	Decompression tested at 53,000 ft.
Over Pressure	4.6.3	
Temperature Variation	5.0	Equipment tested to Category B
Humidity	6.0	Equipment tested to Category 'B, Level 1
Shock	7.0	No test required
Operational	7.2	
Crash Safety	7.3	
Vibration	8.0	Equipment tested without shock mounts to Categories K & S (DO-160B, Table 8-1)
Explosion	9.0	No test required
Waterproofness	10.0	No test required
Fluids Susceptibility	11.0	No test required
Sand and Dust	12.0	No test required
Fungus	13.0	No test required
Salt Spray	14.0	No test required
Magnetic Effect	15.0	Equipment tested as Class 'B'
Power Input	16.0	No test required
Voltage Spike Conducted	17.0	Equipment tested to Category 'A'
Audio Frequency Conducted Susceptibility	18.0	No test required
Induced Signal Susceptibility <sup>1</sup>	19.0	Equipment tested to Category 'B'
Radio Frequency Susceptibility <sup>1</sup>	20.0	Equipment tested to Category 'B'
Radio Frequency Emmission <sup>1</sup>	21.0	Equipment tested to Category 'B'
Other Test <sup>2</sup>		Fire resistance tests were conducted in accordance with Federal Aviation Regulation, Part 25, Appendix F, F.A.R. 25.853 and F.A.R. 25.1359 (d)
REMARKS: — Tests were performed at Electro-Voice, Inc., Sevierville, TN, except the following: <sup>1</sup> Radiometrics Midwest Corp., Lombard, IL <sup>2</sup> Gaynes Testing Laboratories, Chicago, IL		



**ELECTRO-VOICE, INC., 600 Cecil Street, Buchanan, Michigan 49107**

MANUFACTURING PLANTS AT ■ BUCHANAN, MI ■ NEWPORT, TN ■ SEVIERVILLE, TN ■ REDMOND, WA ■ GANANOQUE, ONT.  
 © Electro-Voice, Inc. 1989 ■ Litho In U.S.A. Part Number 531409-939

a MARK IV company

## Free Manuals Download Website

<http://myh66.com>

<http://usermanuals.us>

<http://www.somanuals.com>

<http://www.4manuals.cc>

<http://www.manual-lib.com>

<http://www.404manual.com>

<http://www.luxmanual.com>

<http://aubethermostatmanual.com>

Golf course search by state

<http://golfingnear.com>

Email search by domain

<http://emailbydomain.com>

Auto manuals search

<http://auto.somanuals.com>

TV manuals search

<http://tv.somanuals.com>