

EGOTERIC

I-03

Integrated Amplifier

OWNER'S MANUAL



CAUTION
RISK OF ELECTRIC SHOCK
DO NOT OPEN



CAUTION: TO REDUCE THE RISK OF ELECTRIC SHOCK, DO NOT REMOVE COVER (OR BACK). NO USER-SERVICEABLE PARTS INSIDE. REFER SERVICING TO QUALIFIED SERVICE PERSONNEL.



The lightning flash with arrowhead symbol, within an equilateral triangle, is intended to alert the user to the presence of uninsulated "dangerous voltage" within the product's enclosure that may be of sufficient magnitude to constitute a risk of electric shock to persons.



The exclamation point within an equilateral triangle is intended to alert the user to the presence of important operating and maintenance (servicing) instructions in the literature accompanying the appliance.

IMPORTANT SAFETY INSTRUCTIONS

- 1) Read these instructions.
- 2) Keep these instructions.
- 3) Heed all warnings.
- 4) Follow all instructions.
- 5) Do not use this apparatus near water.
- 6) Clean only with dry cloth.
- 7) Do not block any ventilation openings. Install in accordance with the manufacturer's instructions.
- 8) Do not install near any heat sources such as radiators, heat registers, stoves, or other apparatus (including amplifiers) that produce heat.
- 9) Do not defeat the safety purpose of the polarized or grounding-type plug. A polarized plug has two blades with one wider than the other. A grounding type plug has two blades and a third grounding prong. The wide blade or the third prong are provided for your safety. If the provided plug does not fit into your outlet, consult an electrician for replacement of the obsolete outlet.
- 10) Protect the power cord from being walked on or pinched particularly at plugs, convenience receptacles, and the point where they exit from the apparatus.
- 11) Only use attachments/accessories specified by the manufacturer.
- 12) Use only with the cart, stand, tripod, bracket, or table specified by the manufacturer, or sold with the apparatus. When a cart is used, use caution when moving the cart/apparatus combination to avoid injury from tip-over. 
- 13) Unplug this apparatus during lightning storms or when unused for long periods of time.
- 14) Refer all servicing to qualified service personnel. Servicing is required when the apparatus has been damaged in any way, such as power-supply cord or plug is damaged, liquid has been spilled or objects have fallen into the apparatus, the apparatus has been exposed to rain or moisture, does not operate normally, or has been dropped.

- Do not expose this apparatus to drips or splashes.
- Do not place any objects filled with liquids, such as vases, on the apparatus.
- Do not install this apparatus in a confined space such as a book case or similar unit.
- The apparatus draws nominal non-operating power from the AC outlet with its POWER or STANDBY/ON switch not in the ON position.
- The apparatus should be located close enough to the AC outlet so that you can easily grasp the power cord plug at any time.
- The mains plug is used as the disconnect device, the disconnect device shall remain readily operable.
- Products with Class I construction are equipped with a power supply cord that has a 3-prong grounding plug. The cord of such a product must be plugged into an AC outlet that has a protective grounding connection.
- If the product uses batteries (including a battery pack or installed batteries), they should not be exposed to sunshine, fire or excessive heat.
- Caution should be taken when using earphones or headphones with the product because excessive sound pressure (volume) from earphones or headphones can cause hearing loss.

WARNING: TO PREVENT FIRE OR SHOCK HAZARD, DO NOT EXPOSE THIS APPLIANCE TO RAIN OR MOISTURE.

CAUTION

- DO NOT REMOVE THE EXTERNAL CASES OR CABINETS TO EXPOSE THE ELECTRONICS. NO USER SERVICEABLE PARTS ARE WITHIN.
- IF YOU ARE EXPERIENCING PROBLEMS WITH THIS PRODUCT, CONTACT ESOTERIC FOR A SERVICE REFERRAL. DO NOT USE THE PRODUCT UNTIL IT HAS BEEN REPAIRED.

For U.S.A.

This equipment has been tested and found to comply with the limits for a Class B digital device, pursuant to Part 15 of the FCC Rules. These limits are designed to provide reasonable protection against harmful interference in a residential installation. This equipment generates, uses, and can radiate radio frequency energy and, if not installed and used in accordance with the instructions, may cause harmful interference to radio communications. However, there is no guarantee that interference will not occur in a particular installation. If this equipment does cause harmful interference to radio or television reception, which can be determined by turning the equipment off and on, the user is encouraged to try to correct the interference by one or more of the following measures:

- Reorient or relocate the equipment and/or the receiving antenna.
- Increase the separation between the equipment and receiver.
- Connect the equipment into an outlet on a circuit different from that to which the receiver is connected.
- Consult the dealer or an experienced radio/TV technician for help.

CAUTION

Changes or modifications to this equipment not expressly approved by TEAC CORPORATION for compliance will void the user's warranty.

Contents

Thank you for choosing ESOTERIC. Read this manual carefully to get the best performance from this unit.

What's in the box	3
Before Use	4
Identifying the Parts (Main Unit)	5
Identifying the Parts (Remote Control Unit)	6
Remote Control Unit	7
Connections	8
Speaker Connections	10
Connections When Using as a Pre Amplifier	11
Basic Operation	12
Dimmer/Muting	13
Balance and Input Level Settings	14
Additional Settings	15
Troubleshooting	19
Specifications	20
Rear Panel Layout	21

What's in the box

What's in the box

Check to be sure the box includes all the supplied accessories shown below.

Please contact the store where you purchased this unit if any of these accessories are missing or have been damaged during transportation.

Remote control unit (RC-1251) x 1



Batteries (AA, R6 or SUM-3) x 2



Power cord x 1

Felt pads x 3



- To protect the supporting furniture surface, you may stick the felt pads to the bottom of the feet.

Owner's manual (this document) x 1

- Keep this manual for future reference.

Warranty card x 1

Read this before attempting any operations.

Placement of the unit

⚠ This unit is heavy. Take care to prevent injuries when lifting and installing it.

- High-quality tool steel is used for the spike feet, securely attached to the bottom of the unit. Although the outer feet may appear loose, the weight of the unit causes them to become firm and secure. The design effectively damps and reduces vibration.

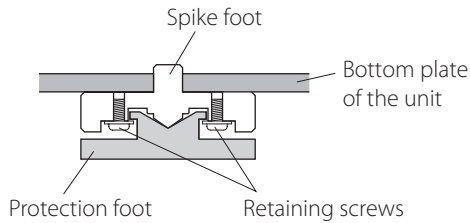

To protect the supporting furniture surface, you may stick the supplied felt pads to the bottom of the protection feet.

- Place the unit in a stable location near the audio system that you will use.
- Choose the installation location of your unit carefully. Avoid placing it in direct sunlight or close to a source of heat. Also avoid locations subject to vibrations and excessive dust, heat, cold or moisture.
- As the unit may become warm during operation, always leave sufficient space around the unit for ventilation. Make sure there is at least 8" (20 cm) of space above and at least 2" (5 cm) of space on each side of the unit. When you install the unit in a rack, use one which has ventilations and take care of temperature of the unit.
- Do not place this unit on a thick carpet.
- When the unit is turned on, switching on the TV may cause lines to appear on the TV screen, depending on the condition of the electric waves of the TV broadcast. This is not malfunction in the unit or the TV. If you see such lines, keep this unit well away from the TV set.

CAUTION

- Do not place any objects on this unit.
- Do not cover this unit with a cloth.
- The voltage supplied to the unit should match the voltage as printed on the rear panel. If you are in any doubt regarding this matter, consult an electrician.
- Do not open the cabinet as this might result in damage to the circuitry or cause electric shock. If a foreign object should get into the unit, contact your dealer or service company.
- When removing the power plug from the wall outlet, always pull directly on the plug, never yank on the cord.

Maintenance

If the surface of the unit gets dirty, wipe it with a soft cloth or use diluted mild liquid soap. Allow the surface of the unit to dry completely before using.

- ⚠ For safety, disconnect the power cord from the socket before cleaning.
- Never spray liquid directly on this unit.
- Do not use thinner or alcohol as they could damage the surface of the unit.
- Avoid allowing rubber or plastic materials to touch this product for long periods of time. It could damage the cabinet.

Identifying the Parts (Main Unit)

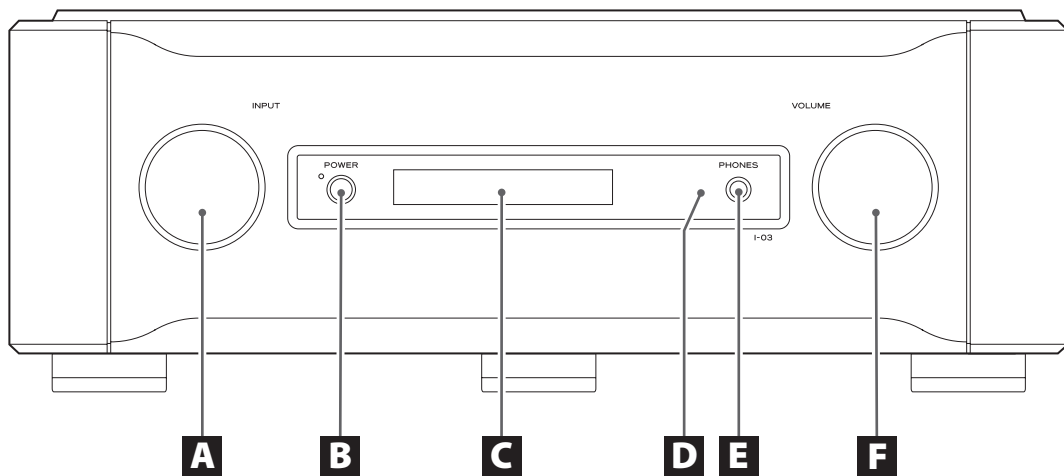

A INPUT

Turn this knob to select a source. Select the terminal that is connected to the device you want to play (page 12).

In setup mode, turn this knob to change the setting of each item (pages 14, 15).

- You can assign names to the input terminals. You can also set the terminals to be skipped when you do not want to use them (pages 17, 18).

B POWER

Press this button to turn the unit on and off.
The blue indicator lights when the unit is turned on.

⚠ Turn the volume to a minimum level before you turn the unit on or off. Failure to do so may cause sudden loud noises and hearing damage when you turn on the unit next time.

- Turn off the power when not using this unit.

C Display

Displays the current input terminal names, volume, setting items etc.

D Remote sensor

When operating the remote control unit, point it towards this area on the front panel.

E PHONES

For private listening, insert a 6.35 mm (1/4") stereo headphone plug into this jack, and then adjust the volume by turning the VOLUME knob.

⚠ TO AVOID DAMAGING YOUR HEARING

Do not connect headphones to the PHONES jack while wearing them. Moreover, do not disconnect headphones or turn the unit on or off while wearing them.

Very loud sounds could be output from the headphones if volume is not turned down prior to plugging on or prior to unplugging. It may cause damage to your hearing.

F VOLUME

Turn this knob clockwise to increase volume and counterclockwise to reduce the volume.

- When the volume value exceeds the maximum total gain value of this unit, the volume display blinks. Lower the volume until the display stops blinking.
- When you set the RCA2 terminals to "THRU", the VOLUME knob does not work on RCA2 signal inputs (page 16).
- When you set the PRE OUT terminals to "REC", the VOLUME knob does not work on this output. In this setting the unit sends a fixed output level for recording (page 16).

⚠ A sudden loud noise heard over the speakers may damage your hearing or the speakers. Turn the volume to a minimum level before you begin playback of source devices. Then gradually increase the volume as desired.

Identifying the Parts (Remote Control Unit)

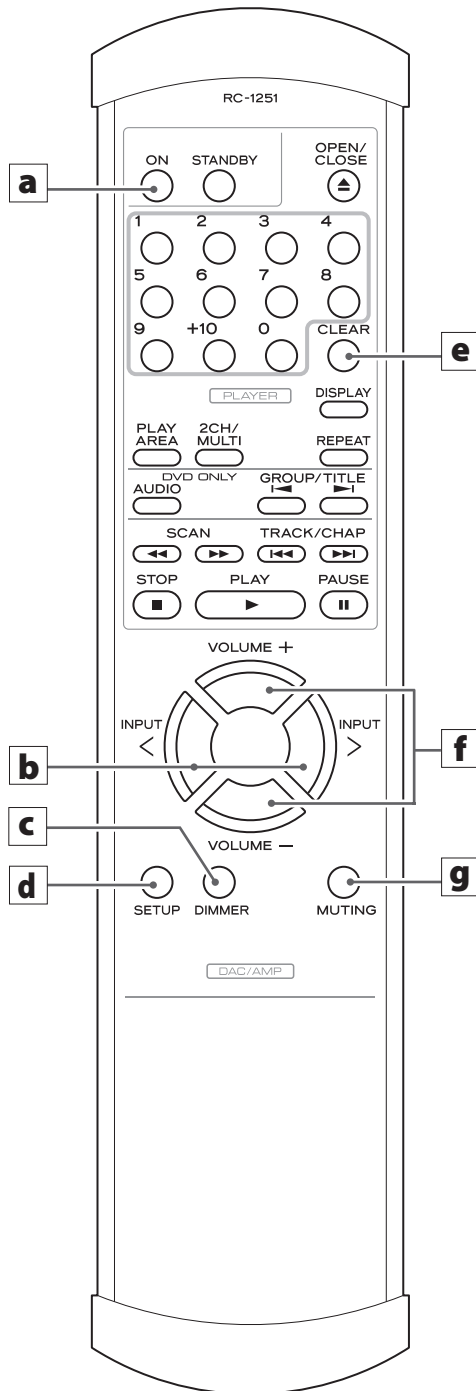

The buttons not mentioned in this chapter do not work with the I-03. However, they can be used for other Esoteric products.

a ON (confirm settings)

Some settings can be changed using this button in "Additional settings" (pages 16, 18).

You can also assign names to the terminals using this button (page 18).

- You can not turn the power on or off using this button.

b INPUT (</>)

Press these buttons to select a source. Select the input terminal that is connected to the device that you want to play (page 12).

In setup mode, press these buttons to change the setting of each item (pages 14, 15).

c DIMMER

Use this button to select one of four brightness levels for the display and indicator lamps (page 13).

d SETUP

Press this button to enter the setup mode for balance and output level adjustments (page 14).

Press this button for more than 2 seconds to enter additional setup modes (page 15).

e CLEAR

In setup mode, use this button to exit the setup mode (pages 14, 15).

f VOLUME (+/-)

Use these buttons to adjust the volume.

- When you set the RCA2 terminals to "THRU" (page 16), or when you set the PRE OUT terminals to "REC" (page 16), the VOLUME control buttons do not work.

g MUTING

Press this button to mute the sound. Press this button again to restore the sound (page 13).

To simplify explanations, instructions in this manual might refer to the main unit or remote control unit only. In such cases, the same controls on the remote control and main unit will operate similarly.

Remote Control Unit

The included remote control allows this unit to be operated from a distance.

Point the remote control unit at the main unit's remote sensor within 23 feet (7 m) of the main unit.

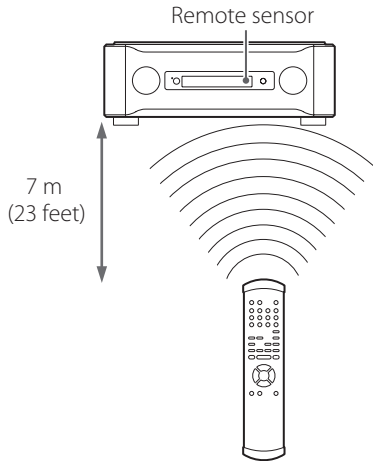

- Depending on the angle, reception might be difficult. Use the remote control from directly in front of the unit as much as possible.
- Even if the remote control unit is used within its effective range, operation by remote control might be impossible if there are any obstacles between the unit and the remote control.
- If direct sunlight or strong artificial illumination shines on the remote sensor, the remote control might not function.
- If the remote control unit is operated near other devices that generate infrared rays, or if other remote controls that use infrared rays are operated near the unit, this unit might operate incorrectly. The other devices might also operate incorrectly.

Battery Installation

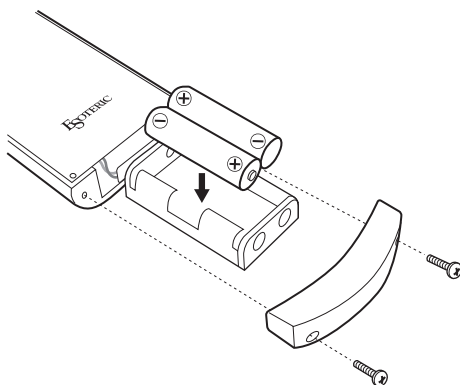

Use a Philips screwdriver to remove the cover from the bottom of the remote control, and slowly pull out the battery case. Insert two AA batteries in the correct \oplus/\ominus orientations, reinsert the case and close the cover.

Battery Replacement

If the operating range between the remote control unit and main unit decreases, the batteries are exhausted. In this case replace the batteries with new ones.

For more information about collection of batteries, please contact your local municipality, your waste disposal service or the point of sale where you purchased the items.

⚠ Precautions concerning batteries

Misuse of batteries could cause them to rupture or leak leading to fire, injury or the staining of nearby things. Please read and observe the following precautions carefully.

- Be sure to insert the batteries with correct positive (\oplus) and negative (\ominus) orientations.
- Use batteries of the same type. Never use different types of batteries together.
- Both rechargeable and non-rechargeable batteries can be used. Refer to the precautions on their labels.
- If the remote control will not be used for a long time (more than a month), remove the batteries to prevent them from leaking.
- If the batteries leak, wipe away the leakage inside the battery compartment and replace the batteries with new ones.
- Do not use batteries of types other than those specified. Do not mix new batteries with old ones or use different types of batteries together.
- Do not heat or disassemble batteries. Never throw batteries into fire or water.
- Do not carry or store batteries with other metallic objects. The batteries could short circuit, leak or explode.
- Never recharge a battery unless it is confirmed to be a rechargeable type.

Connections

⚠ After all other connections are complete, connect the power cord plug to the AC wall socket.

- Read the instructions of each component you intend to use with this unit.
- Be sure to connect each plug securely. To prevent hum and noise, do not bundle the connection cords.

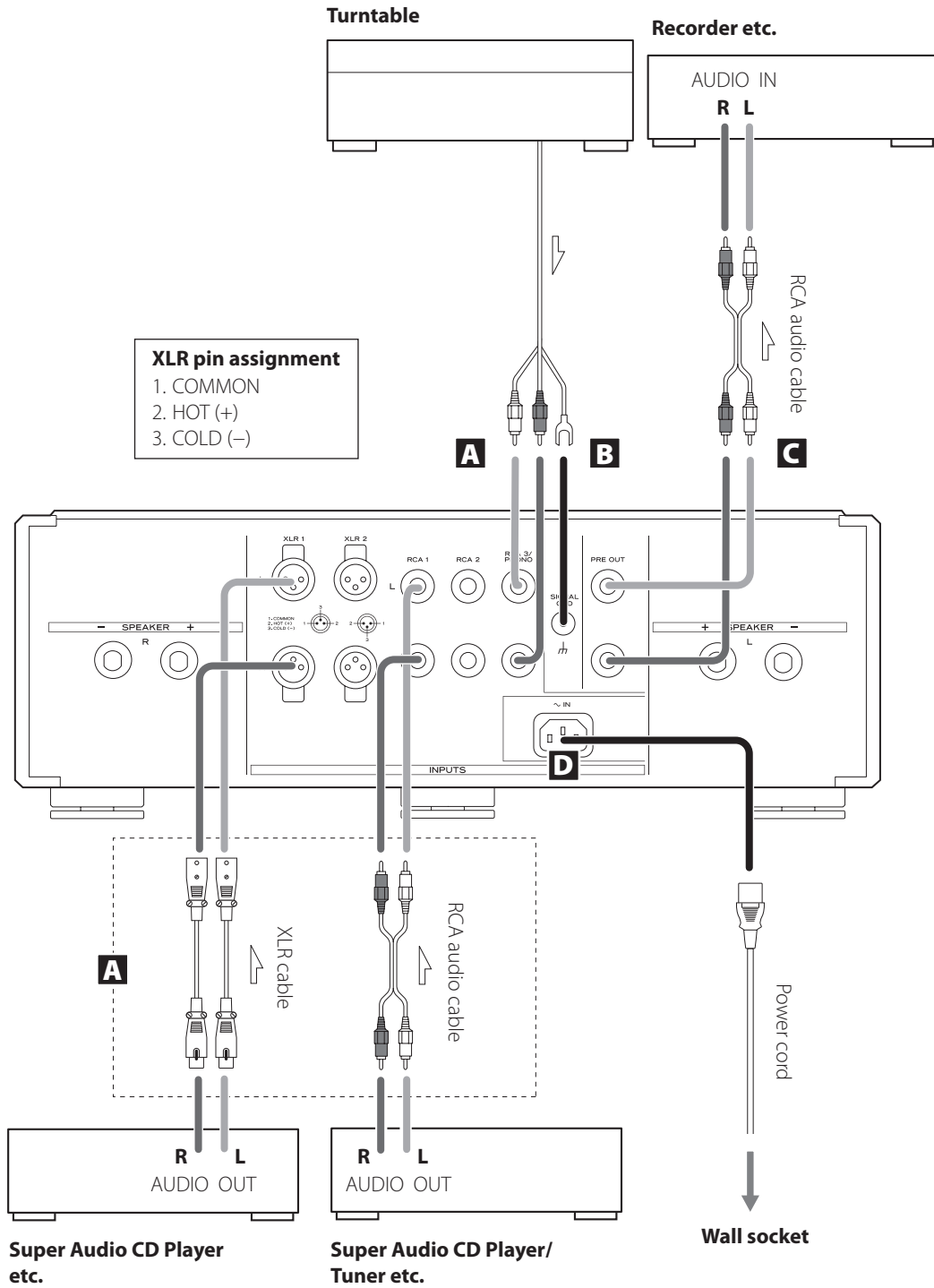

A Analog audio input terminals [INPUTS]

Inputs analog 2-channel audio signals.

Connect these terminals to Super Audio CD players, tuner, etc. using commercially available XLR or RCA audio cables.

Connect the R terminal on this unit to the right (R) terminal of the input source device and the L terminal on this unit to the left (L) terminal of the input source device.

XLR1/2 terminals

Use balanced XLR audio cables.

Push in the XLR plug until the lever clicks. To remove the XLR plug, hold down the lever and pull it out.

RCA1/2/3/PHONO terminals

Use RCA audio cables.

Make sure to connect:

- White plug → White jack (L: left channel)
- Red plug → Red jack (R: right channel)

RCA2/PHONO terminal

You can select whether to use the RCA2 terminals as input terminals or as signal through terminals (page 16).

When a front speaker is used together with an AV amplifier, connecting the RCA2 terminals to the FRONT L/R of the AV amplifier's pre out terminal and setting RCA2 to "THRU" (signal through terminals) will allow the front speaker to be used as a front speaker for the AV amplifier. By this means, the volume of the front speaker can then be controlled with the AV amplifier's volume control.

RCA3/PHONO terminal

You can also connect a turntable to this terminal.

When connecting to a turntable, set the RCA3 setting to "PHONO" (page 17).

- Connect the ground lead of the turntable to the GND terminal [SIGNAL GND] terminal of the I-03.

B GND terminal [SIGNAL GND]

Connection of this terminal with the ground terminal of another chassis may improve sound quality.

- Note that this is NOT an electrical safety ground (earth).
- When a turntable is connected to the RCA3/PHONO terminal, make sure to connect the ground lead of the turntable to this terminal.

C Analog audio output terminals [PRE OUT]

Outputs analog 2-channel audio signals.

Connect these terminals to recorder, etc. using commercially available RCA audio cables.

- You can also connect this unit directly to a power amplifier. This option allows you to use this unit as a pre amplifier, see page 11 "Connections When Using as a Pre Amplifier".
- When connecting to a recorder, set the Pre out setting to "REC" (page 16).

D Power cord receptacle

Connect the power cord to the power cord receptacle.

After all other connections are complete, connect the power cord plug to the AC wall socket.

- ⚠ Do not use any power cords other than the one included with this unit or a power cord specified by ESOTERIC. Use of other power cords may result in fire or cause electric shock.

ESOTERIC uses **ESOTERIC MEXCEL stress-free** cable as a reference. The following items are available in the ESOTERIC **MEXCEL** cable series.

RCA audio cable	BNC digital cable
XLR audio cable	Speaker cable
RCA digital cable	Power cable
XLR digital cable	

Speaker Connections

⚠ After all other connections are complete, connect the power cord plug to the AC wall socket.

- Read the instructions of each component you intend to use with this unit.
- The metal portions of the two separate wires should not touch or an electrical short can occur. Shorted wires can create a fire hazard or induce a failure in your equipment.
- Be sure to connect each plug securely. To prevent hum and noise, do not bundle the speaker cables together with the power cord.

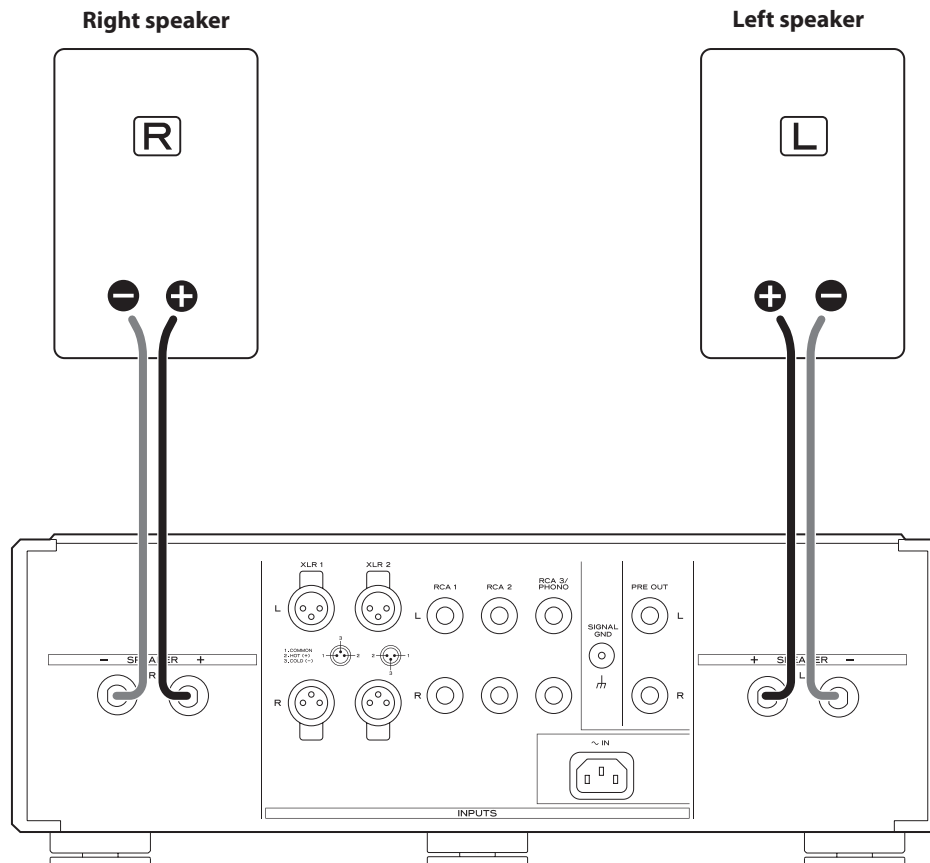

Speaker cables

Connect the speakers to the SPEAKER terminals using commercially available speaker cables.

- Use the shortest speaker cables possible. As cables become longer, electrical resistance increases and damping characteristics may deteriorate. Moreover, inductance and capacitance also increase, degrading the quality of high frequency sounds.
- Ideally, left and right speaker cables should be the same length.

How to connect

Connect the left channel of the SPEAKER terminals to the left speaker, and the right channel of the SPEAKER terminals to the right speaker.

Make sure to connect:

⊕ SPEAKER terminal → ⊕ terminal of the speaker
Using ⊕ side of the speaker cable

⊖ SPEAKER terminal → ⊖ terminal of the speaker
Using ⊖ side of the speaker cable

- Generally, the ⊕ side of the speaker cable is marked to make it distinguishable from the ⊖ side of the cable.
- Turn the terminal cap counterclockwise to loosen, clockwise to tighten.

Using speaker cables with bare wire

Turn the terminal cap counterclockwise to loosen it. Insert the bare wire end properly into the terminal hole, and then tighten the terminal cap.

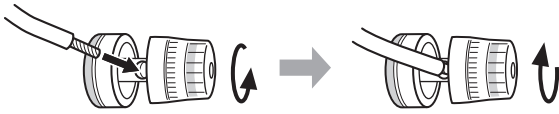

- Do not insert the insulation coating into the terminal hole. Insert only bare wire.
- Make sure it is fastened securely by pulling the cable lightly.

Using speaker cables with spades

Turn the terminal cap counterclockwise to loosen it. Fit the spade around the terminal, and then tighten the terminal cap.

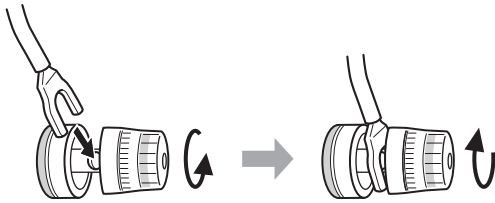

- The inside diameter of spades should be 8 mm (5/16") or more.
- Make sure it is fastened securely by pulling the cable lightly.

Using speaker cables with banana plugs

With the terminal cap tightened, insert the plug into the jack on the end of the cap.

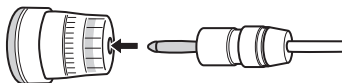

- Read the instructions supplied with the banana plug.

⚠ For European customers

In accordance with European safety regulations, it is not possible to connect banana plugs into the speaker terminals on European models. The holes into which banana plugs are inserted have been covered with black caps. Connect the speakers using spades or bare wires. If the black caps become separated from the terminals, return them to their original position.

⚠ After all connections are complete, connect the power cord plug to the AC wall socket.

- Read the instructions of each component you intend to use with this unit.
- Be sure to connect each plug securely. To prevent hum and noise, do not bundle the connection cords.

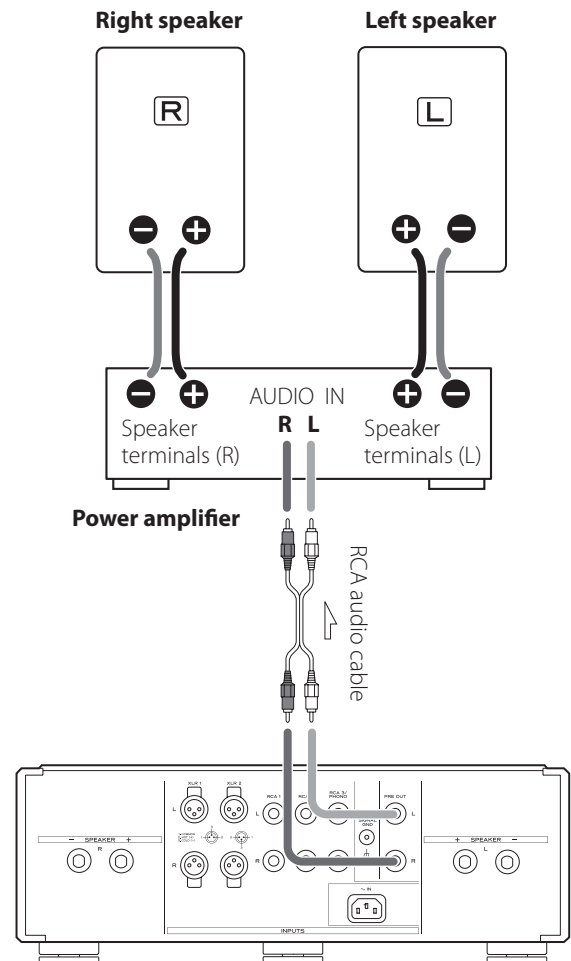

Connect the PRE OUT terminals to the analog audio input terminals of the power amplifier using commercially available RCA audio cables.

Make sure to connect:

- White plug → White jack (L: left channel)
- Red plug → Red jack (R: right channel)

- After the connection, set the Pre out setting to "ON1" or "ON2" (page 16).

1 Turn on the power of the connected input source devices.

2 Press the **POWER** button to turn on the I-03.

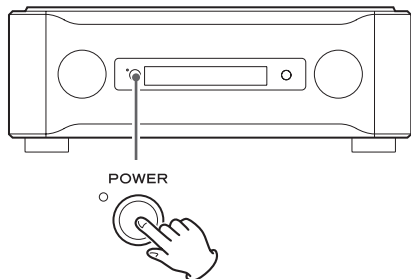

The blue indicator lights.

- When connected to an external power amplifier, turn on the power of the power amplifier after turning on the I-03.

3 Turn the **INPUT** knob to select an input source.

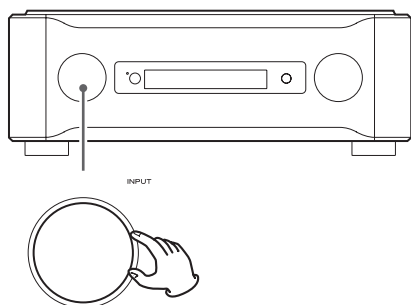

The selected source is shown on the display.

Turning the INPUT knob changes the input source as follows:

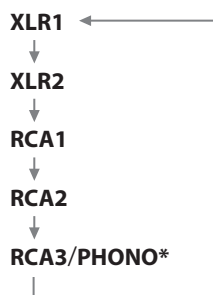

*When you use RCA3 as a PHONO input, select "PHONO" in the RCA3 setting (page 17).

- You can assign names to the input terminals and change the input source names displayed. You can also set the terminals to be skipped when you do not want to use them (pages 17, 18).

4 Play the source, and then adjust the volume by turning the **VOLUME** knob.

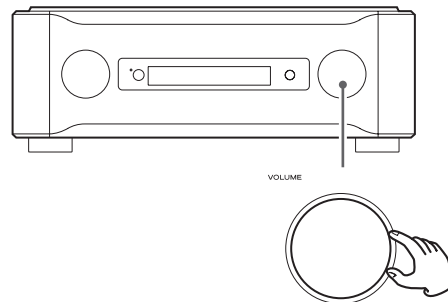

- ⚠ Sudden loud noises may cause hearing damage and other issues. Before starting playback, minimize the volume, and adjust it to a suitable level after playback begins.

Turning the unit off

To prevent sudden noise from the speakers, make sure to turn the unit off in the following way:

1 Stop the playback of the connected component.

- When connected to an external power amplifier, turn off the power amplifier first.

2 Turn the **VOLUME** knob counterclockwise direction to set the volume to minimum.

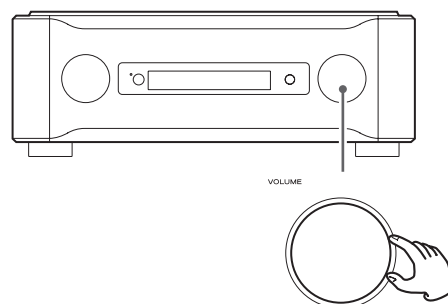

- ⚠ Failure to do so may cause sudden loud noises and hearing damage when you turn on the unit next time.

3 Press the **POWER** button to turn off the I-03.

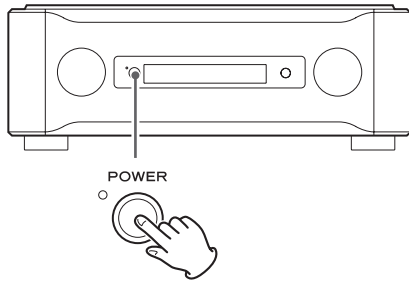

4 Turn off the power of the connected input source devices.

Listening with headphones

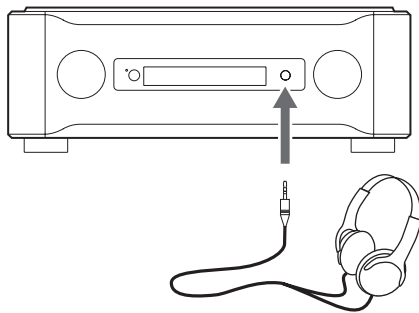

For private listening, insert a 6.35 mm (1/4") stereo headphone plug into the PHONES jack, and then adjust the volume by turning the VOLUME knob.

⚠ TO AVOID DAMAGING YOUR HEARING

Do not connect headphones to the PHONES jack while wearing them. Moreover, do not disconnect headphones or turn the unit on or off while wearing them.

Very loud sounds could be output from the headphones if volume is not turned down prior to plugging on or prior to unplugging. It may cause damage to your hearing.

Dimmer/Muting

Dimmer

You can change the brightness of the display and indicator lamps.

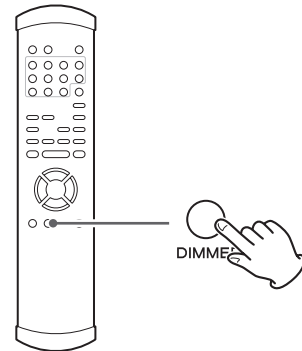

Press the DIMMER button to change the brightness.

Each time the DIMMER button is pressed, the brightness changes as follows:

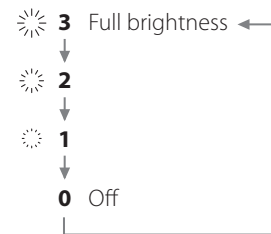

- When you press a button or turn a knob, the illuminations turns to the full brightness for 5 seconds.
- In setup mode, the illuminations turn on with full brightness.

Muting

You can mute the sound temporarily.

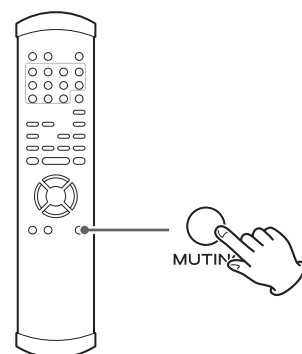

Press the MUTING button to mute the sound.

Press the MUTING button again to restore the sound.

- While muting is engaged, "MUTING" and the name of the selected input terminal alternately blink on the display.
- You can also restore the sound by turning the VOLUME knob or by pressing the VOLUME buttons (+/-).

Balance and Input Level Settings

Balance and output level can be adjusted in the following steps:

- You can specify different settings for each input terminal.

1 Turn the INPUT knob to select the input source.

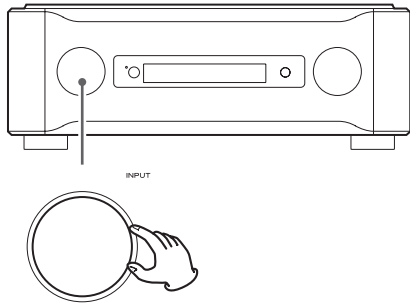

2 Press the SETUP button repeatedly to select the menu item to be set.

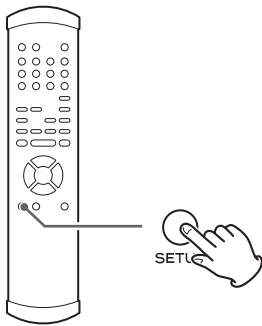

Each time the SETUP button is pressed, the item changes as follows:

Bal > Speaker balance
↓
Level > Output level
↓
Return to the previous display
(Exit setup mode)

- If no button is pressed for more than 10 seconds or the CLEAR button is pressed, the setup mode will be canceled and return to the previous display.

3 Press the INPUT buttons (</>) to change the setting.

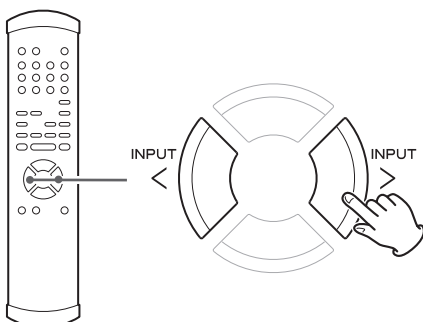

Speaker balance

Display: Bal >***

Adjusts the left/right speaker output balance.

The higher the R value, the more the sound will be balanced to the right speaker. The higher the L value, the more the sound will be balanced to the left speaker.

The default setting is "0.0" (center).

R6.0 (dB)
↕
(0.5dB steps)
↕
0.0 (Center)
↕
(0.5dB steps)
↕
L6.0 (dB)

Output level

Display: Level >***

Adjusts the sound level of the selected input terminal.

The default setting is "0.0" (dB).

+18.0 (dB)
↕
(0.5dB steps)
↕
0.0 (dB)
↕
(0.5dB steps)
↕
-18.0 (dB)

4 Press the SETUP button repeatedly to exit the setup mode.



- You can also press the CLEAR button or wait for more than 10 seconds to exit the setup mode.
- Memorized settings are stored even after the power cord has been disconnected.

Note for settings and sound quality

Bal (Speaker balance) and Level (Output level) are selections related to sound output. These settings and the volume level are detected comprehensively by a micro computer and wholly controlled by a singular volume control amplifier.

It is therefore different from normal amplifiers where sound signals pass through several circuits. In this design implementation, there is no deterioration in sound quality caused by any of these settings.

Additional Settings (1)

Additional settings are available.

- See "Available setup items and settings" from the next page for each setting.

Changing settings

- 1 Press and hold the SETUP button for more than 2 seconds.**

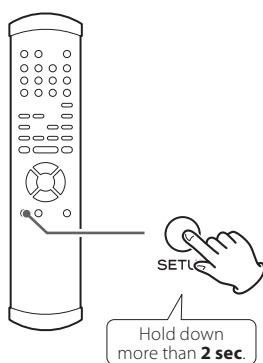

"Disp>" appears on the display and the unit enters the setup mode.

- 2 Press the SETUP button repeatedly to select the menu item to be set.**



Each time the SETUP button is pressed, the item changes as follows:

Disp>	Volume display
↓	
VolTable>	Volume curve
↓	
PreOut>	Pre out
↓	
POutLv	Pre out output level
↓	
RCA2>	RCA2 throughout
↓	
RCA3>	RCA3 PHONO input
↓	
MM/MC>	PHONO Cartridge
↓	
XLR1 =	} Assigning input terminal names/ Setting input terminal to be skipped
↓	
XLR2 =	
↓	
RCA1 =	
↓	
RCA2 =	
↓	
RCA3 =	
↓	
FLaOFF>	Auto display darkening
↓	
Setup>	Returning to factory settings
↓	
Return to the previous display	
(Exit setup mode)	

- The item names will change according to the current input terminal or settings you have made.
- If no button is pressed for more than 10 seconds or the CLEAR button is pressed, the setup mode will be canceled and return to the previous display.

- 3 Press the INPUT buttons (</>) to change the setting.**

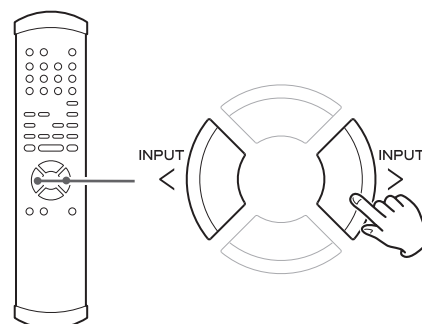

See "Available setup items and settings" from the next page for each setting.

Repeat steps **2** and **3** as required.

- 4 Press the SETUP button repeatedly to exit the setup mode.**



- You can also press the CLEAR button or wait for more than 10 seconds to exit the setup mode.
- Memorized settings are stored even after the power cord has been disconnected.

Available setup items and settings

Volume display

Display: Disp>***

Changes the volume display.
The default setting is "Step".

Step

The volume level changes in steps from 0 to 99.

dB

The volume level changes in steps from $-\infty$ dB dB to 0.0 dB.
"---" is displayed when no sound ($-\infty$ dB) comes out.

Volume curve

Display: VolTable>***

The volume of this unit can be adjusted within the range of $-\infty$ dB to 0.0 dB. This volume range is assigned to 99 steps (hereafter referred to as "volume curve"). You can select the volume curve from 5 different types (A, B, C, D, and E).
The default setting is "A".

Pre out

Display: PreOut>***

Changes the output setting of the PRE OUT terminals.
The default setting is "OFF".

OFF

Output from the PRE OUT terminals is deactivated.

ON1

Output from the PRE OUT terminals is activated.
Sound signals are output from both the speakers connected directly to this unit and to those of a device connected to PRE OUT terminals.

Select "ON1" when you use bi-amping by connecting an external power amplifier to this unit.

The volume can be adjusted by turning the VOLUME knob.

ON2

Output from the PRE OUT terminals is activated.
No sound signals are output from the speakers connected to this unit. In addition, the power amplifier function of this unit is deactivated.

Select "ON2" when you use this unit only as a pre-amplifier.

The volume can be adjusted by turning the VOLUME knob.

- When headphones are plugged in to this unit, sound signals are output as they are.

REC

Output from the PRE OUT terminals is activated and the unit sends a fixed output level for recording.

The volume level adjusted using the VOLUME knob is ignored. Sound signals are output as they are.

Select "REC" when you connect a recorder to the PRE OUT terminals.

Pre out output level

Display: POutLv***

Adjusts the pre-amp function output level.

This setting menu is available when "ON1", "ON2", or "REC" is selected in the Pre Out setting (see left).

The default setting is "0.0" (dB).



RCA2 throughout

Display: RCA2>***

You can select whether to use the RCA2 terminals as normal input terminals or as signal through terminals.

The default setting is "NML".

NML (Normal)

Select this to use the RCA2 terminals as normal input terminals.

THRU (Through)

The volume level adjusted using the VOLUME knob is ignored when this setting is selected. Sound signals passing through the RCA2 terminals are output as they are.

After selecting "THRU", **press the ON button** to activate the setting.

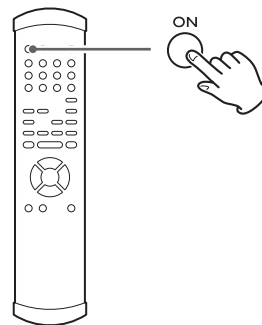

"THRU" appears on the display instead of the volume level. This setting is also known as "Home theater pass-through."

When a front speaker is used together with an AV amplifier, connecting the RCA2 terminals to the FRONT L/R of the AV amplifier's pre out terminal and setting RCA2 to "THRU" (signal through terminals) will allow the front speaker to be used as a front speaker for the AV amplifier. By this means, the volume of the front speaker can then be controlled with the AV amplifier's volume control.

- When "THRU" is selected for RCA2 terminals and sound signals are output from the terminals, you cannot use the VOLUME knob/control buttons of this unit.

⚠ When you select "THRU", be sure to connect the RCA2 terminals to a device that allows you to control the volume level at the device side. Also make sure to adjust the volume level of the device to the minimum before you select "THRU". Gradually increase the volume level of the connected device. Failure to do so may allow very loud sounds to be output suddenly and it could cause damage to the speakers and/or to your hearing.

RCA3 PHONO input

Display: RCA3>***

You can assign the RCA3 terminals as a phono input terminals. The default setting is "LINE".

LINE

Select this to use the RCA3 terminals as line input terminals. Select this setting when you connect a device other than a turntable to the RCA3 terminals.

PHONO

Select this to use the RCA3 terminals as phono input terminals. Select this setting when you connect a turntable to the RCA3 terminals.

When you select this setting, set the cartridge type (see below).

⚠ If a device other than a turntable is connected to the RCA3 terminals with "PHONO" selected, a sudden loud noise could be heard over the speakers. Be sure to select "LINE" when a device other than a turntable is connected to the RCA3 terminals.

PHONO Cartridge

Display: MM/MC>***

Select the cartridge type of your turntable connected to this unit. This setting menu is available when "PHONO" is selected in the RCA3 PHONO input setting (see above). The default setting is "MM".

MM

Select this when you use a MM (Moving magnet) cartridge.

MC

Select this when you use a MC (Moving coil) cartridge.

Assigning input terminal names/ Setting input terminal to be skipped

Display: (Input terminal name) = ***

You can assign names to the input terminals and change the input source names displayed. You can also set the terminals to be skipped when you do not want to use them.

For example, when a super audio CD player is connected to the RCA2 terminals and a DVD player is connected to the RCA3 terminals, the RCA2 and RCA3 terminals can be set to "SACD" and "DVD" respectively while the other terminals can be set to "*skip". When the INPUT knob is turned, only "SACD" and "DVD" will be selected, making it easier to select only the terminals you want to use.

Changing the terminal name

Press the INPUT buttons (</>) repeatedly to change the current input terminal name while the input terminal name (XLR1, XLR2, RCA1, RCA2 or RCA3) and "=" are displayed.

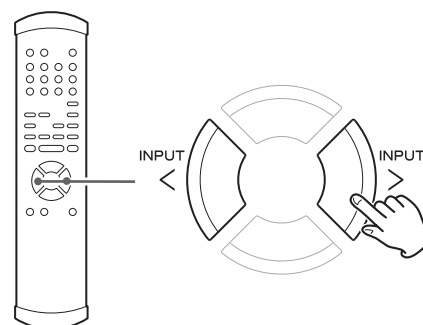

Each time the INPUT buttons (</>) is pressed, the available terminal names changes as follows:

CD → DAC → SACD → DVD → CD-R → DVD-R
 → TAPE → MD → TUNER → PC → MP3 → AUX
 → TV → VIDEO → VCR → * skip → ■■■■■■ (editable)

Setting the terminal to be skipped

Press the INPUT buttons (</>) repeatedly until "*skip" appears while the input terminal name (XLR1, XLR2, RCA1, RCA2 or RCA3) and "=" are displayed.

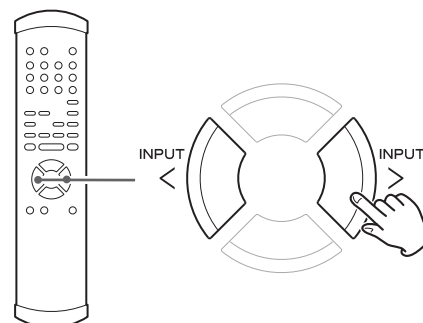

- The skip function will not work when all terminals are set to "*skip".

Creating your own input terminal name.

- 1 Press the INPUT buttons (</>) repeatedly until "■■■■■" appears while the input terminal name (XLR1, XLR2, RCA1, RCA2 or RCA3) and "=" are displayed.**

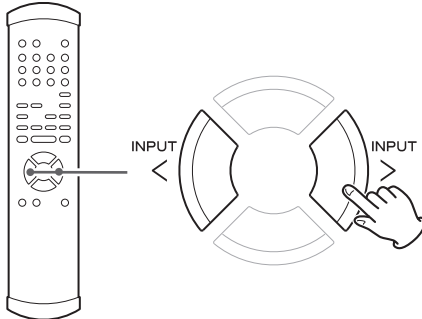

- 2 Press the ON button.**

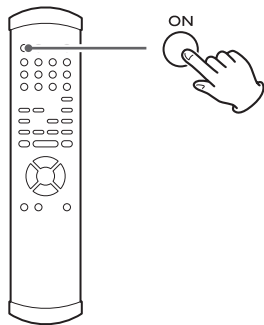

- 3 Input the letters.**

Press the INPUT buttons (</>) to move the cursor.
Press the the VOLUME buttons (+/-) to select the letters.

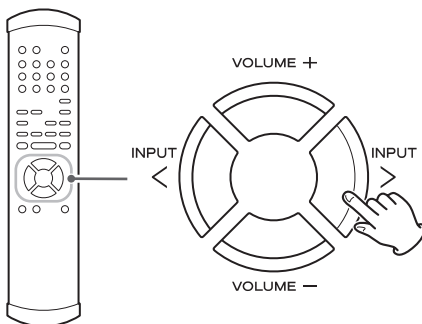

- You can input up to 5 letters.

- 4 When you have finished inputting the letters, press the ON button to confirm the selection.**



Available Letters

Alphabet: A to Z, a to z

Numbers: 0 to 9

Symbols: ! " # \$ % & ' () * + , - . / : ; < = > ? @ (blank) ■

Auto display darkening

Display: FLAOff>***

Sets the time before the display turns off automatically when no operation is done for the specific period of time.
The default setting is "30m".

15m

Turns off the display automatically when no operation is done for 15 minutes.

30m

Turns off the display automatically when no operation is done for 30 minutes.

60m

Turns off the display automatically when no operation is done for 60 minutes.

OFF

The unit does not turn off the display automatically.

- If the display is left on with the same indication for a long time, brightness irregularities can occur. For this reason, we recommend that you enable automatic display darkening.

Returning to factory settings

Display: Setup>***

Memorized settings are stored even after the power cord has been disconnected. If you have made changes through the setup process, and want to restart from a known set of options, restore the unit to the default factory settings as follows:

While "Setup>" is displayed, **press the ON button** to execute the initialization process.

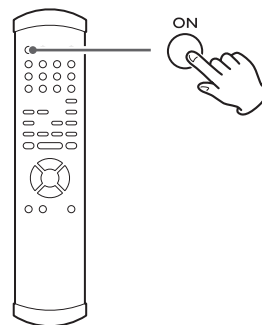

"Setup CLR" appears on the display and the unit returns to the factory settings.

If you experience any problems with the unit, please take a moment to look through this chart and see if you can solve the problem yourself before you call your dealer or ESOTERIC customer service/technical support.

Moreover, the problem might be caused by something other than this unit. Confirm that connected devices are also being used properly.

No power.

- ➔ Check the connection to the AC power source. Check and make sure the AC source is not a switched outlet and if it is, the switch is turned on. Make sure there is power to the AC outlet by plugging another item such as a lamp or a fan.

Remote control does not work.

- ➔ Press the POWER button of the main unit to turn it on.
- ➔ Be sure that batteries have been installed. If the batteries are exhausted, change the batteries (Page 7).
- ➔ Use the remote control unit within the effective range (23 feet/7 m) and point it toward the remote sensor on the front panel.
- ➔ Make sure that there are no obstacles between the remote control unit and the main unit.
- ➔ If a fluorescent light is near the unit, turn it off.

Other units with remote controls operate incorrectly.

- ➔ Note that other units with remote controls may operate incorrectly because of infrared light "overspill" when you operate the remote control of this unit.

There is no sound or only a very low-level sound is heard.

- ➔ Adjust the volume by turning the VOLUME knob.
- ➔ Select the proper input source by turning the INPUT knob.
- ➔ If the muting is engaged, press the MUTING button.
- ➔ Check that the speakers and components are connected properly.
- ➔ Check the operation of the connected component.
- ➔ The connected speakers will make no sound when headphones are plugged into this unit. Disconnect the headphones.
- ➔ When you use this unit as a pre amplifier, set the Pre out setting to "ON1" or "ON2" (page 16).
- ➔ The connected speakers will make no sound when the Pre out setting is set to "ON2" (page 16).
- ➔ The connected speakers will make no sound when the protection circuit is activated. Check the items on the right.

"AMP ERR!" blinks on the display.

- ➔ The protection circuit is activated. Check the items on the right.

Cannot select the input terminal.

- ➔ The input terminal might be set to be skipped. Assign the input terminal a name other than "*skip" (page 17).

VOLUME knob/buttons do not work.

- ➔ When you set the RCA2 terminals to "THRU" (signal through terminals), the VOLUME knob/buttons do not work on their terminals (page 16).
- ➔ When you set the PRE OUT terminals to "REC", the VOLUME knob/buttons do not work on their terminals (page 16).

Volume display blinks.

- ➔ The volume value exceeds the maximum total gain value of the volume control. Lower the volume until the display stops blinking.

Since this device uses a microcontroller, external noise and other interference can cause the unit to malfunction. If this occurs, turn the power off and restart operations after waiting for about one minute.

Protection Circuit

This unit has a built-in protection circuit.

"AMP ERR!" blinks on the display when the protection circuit is activated. In this case, check the following items:

Check the speaker cables

- ➔ There might be a ⊕/⊖ short in a speaker cable. Turn the unit off, and then check the cables.

Check if the volume is too high

- ➔ Lower the volume.

Check if the unit is too warm

- ➔ The protection circuit might be activated because the temperature inside the unit has become too hot. Turn the unit off, and wait to let it cool down. Always be sure to allow adequate space for airflow around the unit when in operation.

If the protection circuit continues to be activated, please contact your dealer or an ESOTERIC authorized service center.

Specifications

Speaker Outputs

Rated output power	240 W + 240 W (1 kHz, 6 Ω)
Maximum output power	320 W + 320 W (1 kHz, 0.1 %, 6 Ω) (JEITA)
Total harmonic distortion	0.03 % (1 kHz, 6 Ω)
Frequency response	5 Hz - 70 kHz (+1 dB, -3 dB, 6 Ω)
Signal-to-noise ratio (S/N)	110 dB (JEITA)
Minimum required impedance	4 Ω
Speaker output terminals	Binding posts x 1 stereo

Analog audio inputs

Jacks	RCA jacks x 3 stereo
	RCA2: can be connected to an AV-amplifier's pre-output
	RCA3: can be switched among LINE, PHONO MM and PHONO MC
	XLR jacks x 2 stereo
Input impedance	LINE: 100 kΩ
	PHONO MM: 47 kΩ
	PHONO MC: 100 kΩ

Analog audio outputs

Jacks	RCA jacks x 1 stereo
Output impedance	470 Ω

General

Power supply	
European model	AC 230 V, 50 Hz
U.S.A./Canadian model	AC 120 V, 60 Hz
Korean model	AC 220 V, 60 Hz
Power consumption	280 W
External dimensions (W x H x D)	445 x 162 x 468 mm (17 1/2" x 6 3/8" x 18 3/8")
	(including protrusions)
Weight	31 kg (68 lb)
Operating temperature	+5 °C to +35 °C
Operating humidity	.5 % to 85 % (no condensation)
Storage temperature	-20 °C to +55 °C

Accessories

Remote control unit (RC-1251)	x 1
Batteries (AA, R6 or SUM-3)	x 2
Power cord	x 1
Felt pads	x 3
Owner's manual (this document)	x 1
Warranty card	x 1

External dimensions

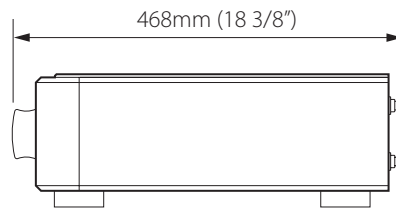
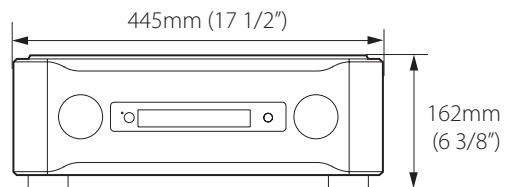

- Design and specifications are subject to change without notice.
- Weight and dimensions are approximate.
- Illustrations may differ slightly from production models.

Rear Panel Layout

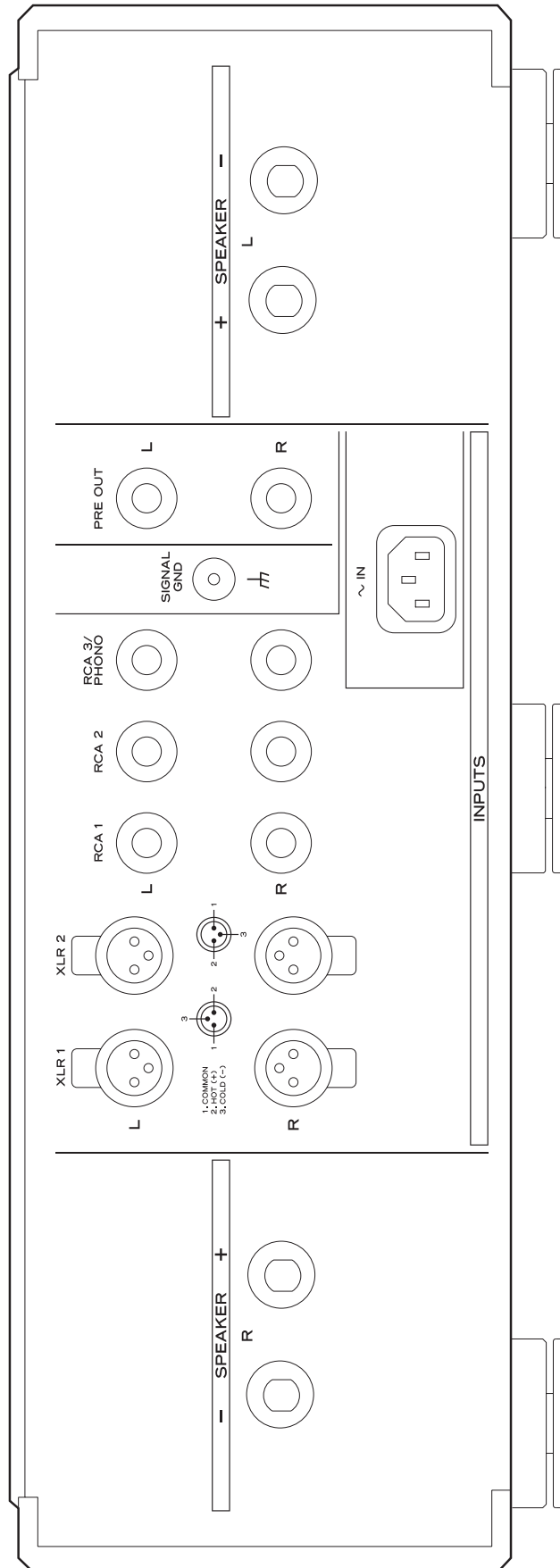

For European customers

Disposal of electrical and electronic equipment

- (a) All electrical and electronic equipment should be disposed of separately from the municipal waste stream via collection facilities designated by the government or local authorities.
- (b) By disposing of electrical and electronic equipment correctly, you will help save valuable resources and prevent any potential negative effects on human health and the environment.
- (c) Improper disposal of waste electrical and electronic equipment can have serious effects on the environment and human health because of the presence of hazardous substances in the equipment.
- (d) The Waste Electrical and Electronic Equipment (WEEE) symbol, which shows a wheeled bin that has been crossed out, indicates that electrical and electronic equipment must be collected and disposed of separately from household waste. 
- (e) Return and collection systems are available to end users. For more detailed information about the disposal of old electrical and electronic equipment, please contact your city office, waste disposal service or the shop where you purchased the equipment.

Disposal of batteries and/or accumulators

- (a) Waste batteries and/or accumulators should be disposed of separately from the municipal waste stream via collection facilities designated by the government or local authorities.
- (b) By disposing of waste batteries and/or accumulators correctly, you will help save valuable resources and prevent any potential negative effects on human health and the environment.
- (c) Improper disposal of waste batteries and/or accumulators can have serious effects on the environment and human health because of the presence of hazardous substances in them.
- (d) The WEEE symbol, which shows a wheeled bin that has been crossed out, indicates that batteries and/or accumulators must be collected and disposed of separately from household waste. 
Pb, Hg, Cd
If a battery or accumulator contains more than the specified values of lead (Pb), mercury (Hg), and/or cadmium (Cd) as defined in the Battery Directive (2006/66/EC), then the chemical symbols for those elements will be indicated beneath the WEEE symbol.
- (e) Return and collection systems are available to end users. For more detailed information about the disposal of waste batteries and/or accumulators, please contact your city office, waste disposal service or the shop where you purchased them.

China RoHS (电子信息产品污染控制管理办法)

- The information in the following table is only applicable to products for sale in the People's Republic of China.
- The products sold in the European area are manufactured in accordance with the European RoHS Directive.
- Les informations contenues dans le tableau suivant sont applicables uniquement aux produits en vente en République populaire de Chine.
- Les produits vendus en Europe sont fabriqués conformément avec la directive européenne RoHS.
- La información de la siguiente tabla se aplica únicamente a los productos de venta en la República Popular China.
- Los productos vendidos en el espacio europeo se fabrican en conformidad con la directiva europea RoHS.

产品有毒有害物质或元素的名称及含量

机种: I-03		有毒有害物质或元素					
品名		铅 (Pb)	汞 (Hg)	镉 (Cd)	六价铬 (Cr(VI))	多溴联苯 (PBB)	多溴二苯醚 (PBDE)
1	CHASSIS部份	×	○	○	○	○	○
2	PANEL部份	○	○	○	○	○	○
3	FOOT部份	○	○	○	○	○	○
4	螺丝部份	○	○	○	○	○	○
5	PCB Assy部份	×	○	○	○	○	○
6	线材部份	○	○	○	○	○	○
7	SEAL部份	○	○	○	○	○	○
8	AC CORD部份	×	○	○	○	○	○
9	附属品部份	○	○	○	○	○	○
10	包装部份	○	○	○	○	○	○

○：表示该有毒有害物质在该部件所有均质材料中的含量均在 SJ/T11363-2006 标准规定的限量要求以下。
 ×：表示该有毒有害物质至少在该部件的某一均质材料中的含量超出 SJ/T11363-2006 标准规定的限量要求。
 （针对现在代替技术困难的电子部品及合金中的铅）

ESOTERIC

TEAC CORPORATION	1-47 Ochiai, Tama-shi, Tokyo 206-8530 Japan Phone: (042) 356-9156 e-mail: eso-os@tec.teac.co.jp
TEAC AMERICA, INC.	7733 Telegraph Road, Montebello, California 90640 U.S.A. Phone: (323) 726-0303 e-mail: esoteric_info@teac.com
TEAC CANADA LTD.	5939 Wallace Street, Mississauga, Ontario L4Z 1Z8, Canada Phone: (905) 890-8008
TEAC MEXICO, S.A. DE C.V.	Río Churubusco 364, Colonia Del Carmen, Delegación Coyoacán, CP 04100, México DF, México Phone: (5255)5010-6000
TEAC UK LTD.	Suites 19 & 20, Building 6, Croxley Green Business Park, Hatters Lane, Watford, Hertfordshire, WD18 8TE, U.K. Phone: (0845) 130-2511
TEAC EUROPE GMBH	Bahnstraße 12, D-65205 Wiesbaden-Erbenheim, Deutschland Phone: 0611-71580

This appliance has a serial number located on the rear panel. Please record the serial number and retain it for your records.

Model name: I-03 Serial number: _____

0411·MA-1693A

Free Manuals Download Website

<http://myh66.com>

<http://usermanuals.us>

<http://www.somanuals.com>

<http://www.4manuals.cc>

<http://www.manual-lib.com>

<http://www.404manual.com>

<http://www.luxmanual.com>

<http://aubethermostatmanual.com>

Golf course search by state

<http://golfingnear.com>

Email search by domain

<http://emailbydomain.com>

Auto manuals search

<http://auto.somanuals.com>

TV manuals search

<http://tv.somanuals.com>