

USER'S MANUAL

# EVO REV 400 ELLIPTICAL TRAINER

MODEL NUMBER: REV 400



[www.evofitness.com](http://www.evofitness.com)

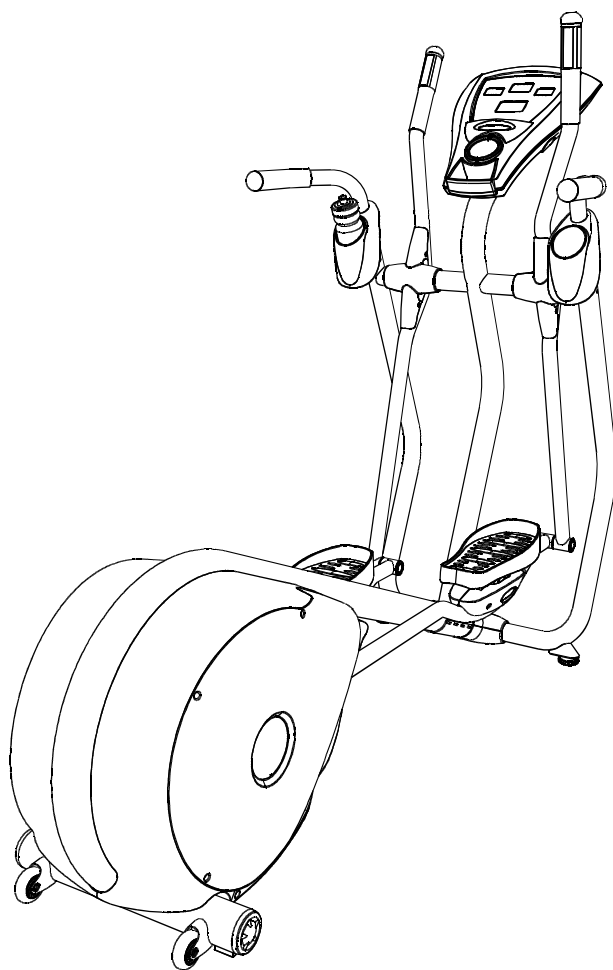

USER WEIGHT LIMITATION: **300 lbs.**

TOLL FREE CUSTOMER SERVICE NUMBER: **1.888.800.1167**

SERIAL NUMBER (found on frame):

## PREASSEMBLY

### **For future service or related questions:**

Please staple your receipt and/or write in the name and phone number of the retail store where you purchased your EVO Fitness Elliptical Trainer.

Name: \_\_\_\_\_ Phone Number: \_\_\_\_\_ Receipt: \_\_\_\_\_

### **Open the boxes:**

You are now ready to open the boxes of your new equipment. Make sure to inventory all of the parts that are included in the boxes. Check the Parts List for a full count of the number of parts included for this product to be assembled properly. If you are missing any parts or have any assembly questions call your local EVO dealer or contact us directly at 888-800-1167.

### **Gather your tools:**

Before starting the assembly of your unit, make sure that you have gathered all the necessary tools you may require to assemble the unit properly. Having all of the necessary equipment at hand will save time and make the assembly quick and hassle-free.

### **Clear your work area:**

Make sure that you have cleared away a large enough space to properly assemble the unit. Make sure the space is free from anything that may cause injury during assembly. After the unit is fully assembled, make sure there is a comfortable amount of free area around the unit for unobstructed operation.

### **Invite a friend:**

Some of the assembly steps may require heavy lifting. It is recommended that you obtain the assistance of another person when assembling this product.

### **User Weight Limitation:**

Please note that there is a weight limitation for this product. **If you weigh more than 300lbs. it is not recommended that you use this product. Serious injury may occur if the user's weight exceeds the limit shown here.** This product is not intended to support users whose weight exceeds this limit.

**HARDWARE COMPARISON CHART**

**Hardware chart:**

For your convenience, we have identified the hardware used in the assembly of this product. This chart is provided to help you identify those items that may be unfamiliar to you.

NO.	DESCRIPTION	QTY.
30	20 x 91 x M14mm Bolt	2
77	M8 x 60mm Bolt	2
78	M10 x 90mm Bolt	2
79	M8 x 80mm Bolt	2
80	M8 x 15mm Bolt	2
88	M14 Nut	2
91	ID 8mm Curve Washer	4
97	M4 x 12mm Screw	8
98	M10 Nut	2
100	M4 x 50mm Screw	1
101	ID 10mm Curve Washer	2
102	M4 x 15mm Screw	8
105	M6 x 20mm Bolt	4
A	M14 Bushing Tool	1
B	5mm Allen Key	1
C	8mm Wrench	1
D	Wrench for M10 Nut	1
E	Wrench	1

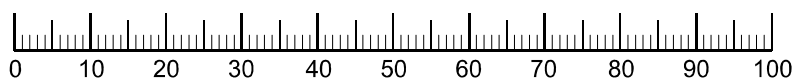
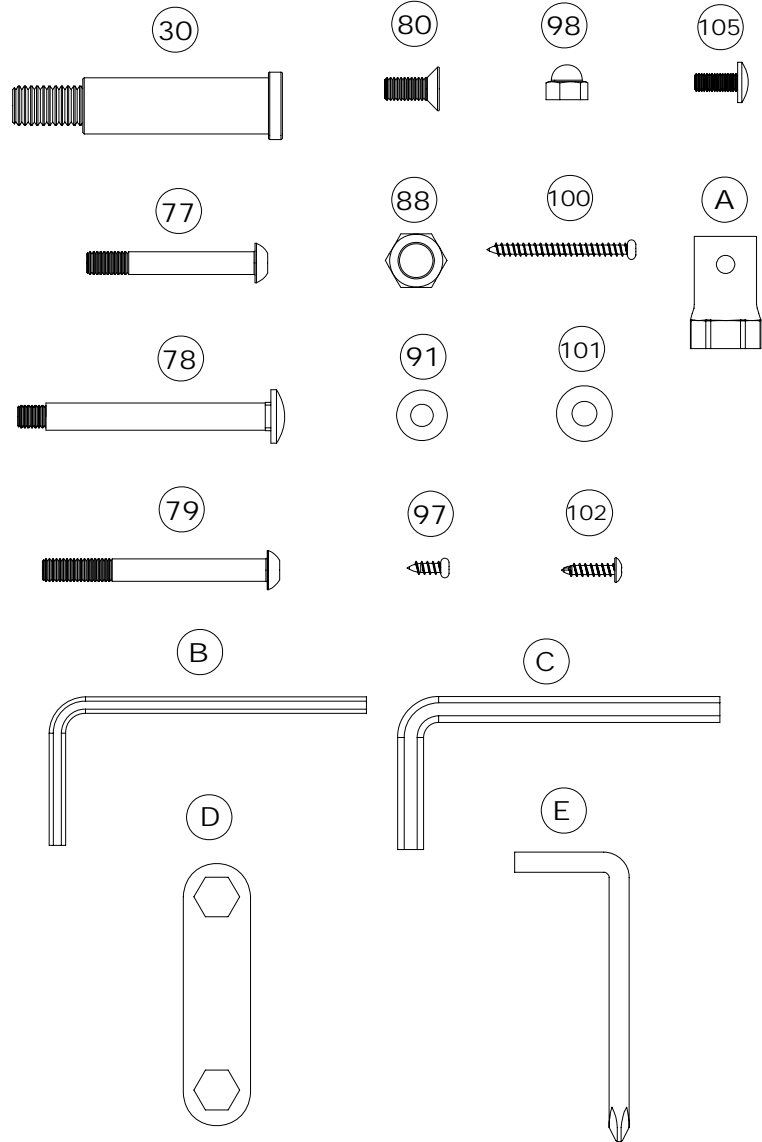

MILLIMETERS

**HARDWARE COMPARISON CHART**

**Hardware chart:**

For your convenience, we have identified the hardware used in the assembly of this product. This chart is provided to help you identify those items that may be unfamiliar to you.

NO.	DESCRIPTION	QTY.
1	Computer	1
2	Front Upright Frame	1
5	Left Upright	1
6	Right Upright	1
7	Hand Rail Frame – Left	1
8	Hand Rail Frame – Right	1
9	Water Bottle Holder	2
13	Handlebar Cover	2
14	Handlebar Inside Cover	4
16	Handlebar – Left	1
17	Handlebar – Right	1
59	Front Frame Cover – Upper	1
60	Front Frame Cover – Lower	1
99	Frame	1
107	Water Bottle	1

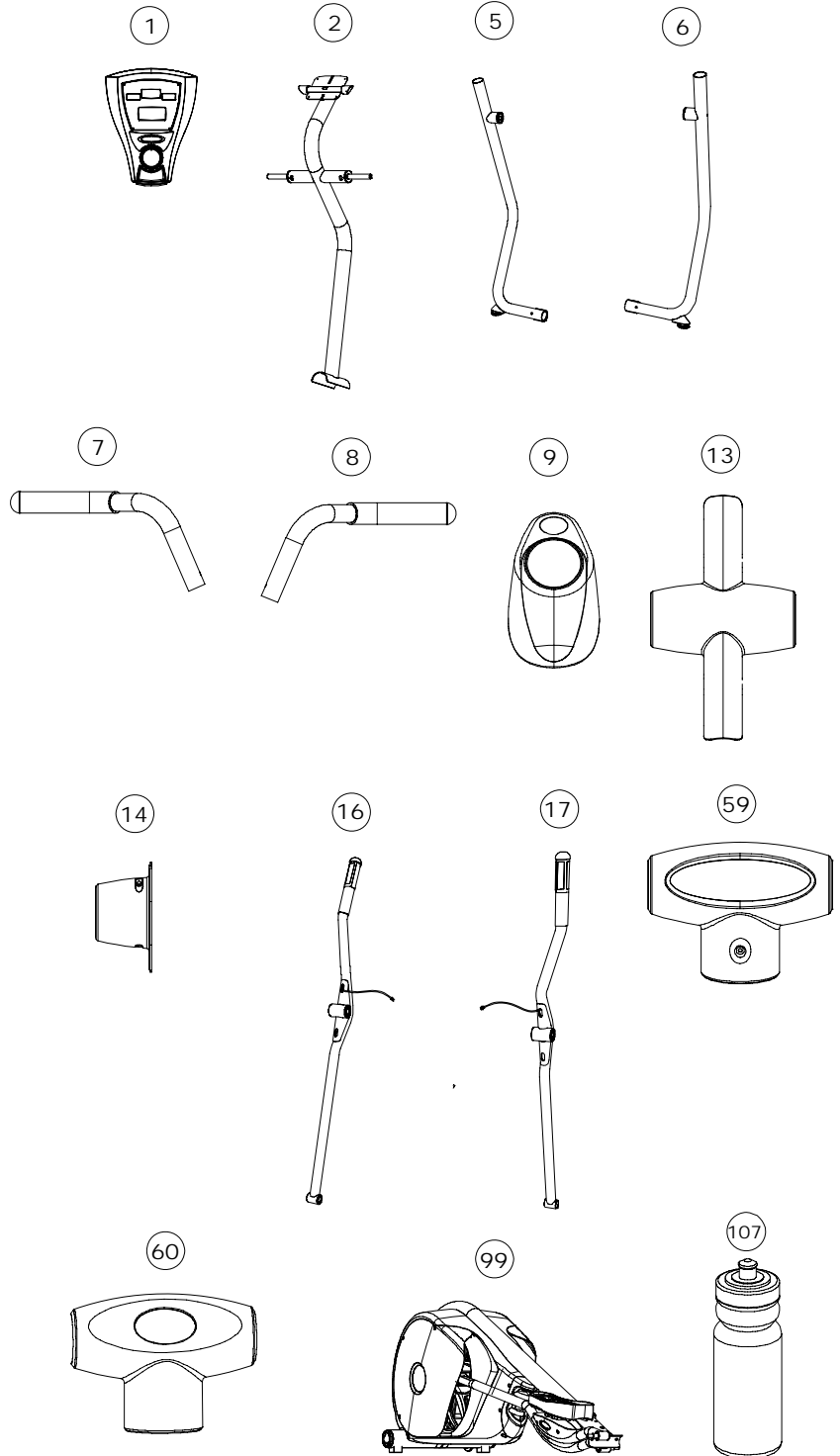

PARTS LIST

No.	Description	Qty.	Order No.	No.	Description	Qty.	Order No.
1	Computer	1	REV400-01	30	20 x 91 x M14mm Bolt	2	REV400-30
2	Front Upright Frame	1	REV400-02	31	Bearing 6804zz	4	REV400-31
3	Console Small Cover - Left	1	REV400-03	32	Level Adjusters	2	REV400-32
4	Console Small Cover - Right	1	REV400-04	33	Pedal Arm - Left	1	REV400-33
5	Left Upright	1	REV400-05	34	Pedal Arm - Right	1	REV400-34
6	Right Upright	1	REV400-06	35	C Clips	2	REV400-35
7	Hand Rail Frame - Left	1	REV400-07	36	Bearing 2202zz	2	REV400-36
8	Hand Rail Frame - Right	1	REV400-08	37	Pedal Arm Adjusters Bushing	2	REV400-37
9	Water Bottle Holder	2	REV400-09	38	Bearing	2	REV400-38
10	Hand Rail Cap	4	REV400-10	39	Pedal Arm Rear Shaft	2	REV400-39
11	Handlebar Pivot Outside Bushing	2	REV400-11	40	Pedal Arm Rear Shaft Bushing	2	REV400-40
12	Handlebar Pivot Inside Bushing	2	REV400-12	41	Adjuster Motor	1	REV400-41
13	Handlebar Cover	2	REV400-13	42	Spiral Shaft	1	REV400-42
14	Handlebar Inside Cover	4	REV400-14	43	Motor Bracket	1	REV400-43
15	Bearing 6004zz	4	REV400-15	44	Volute Shaft	1	REV400-44
16	Handlebar - Left	1	REV400-16	45	Motor Control Board	1	REV400-45
17	Handlebar - Right	1	REV400-17	46	Magnet Bracket Shaft	1	REV400-46
18	Pedal Arm Front Pivot Cover - Left	4	REV400-18	47	Spring	1	REV400-47
19	Hand Rail Frame Foam Grips	2	REV400-19	48	Magnet Bracket Shaft	1	REV400-48
20	Handlebar Foam Grips	2	REV400-20	49	Crank Disk Support Cover	2	REV400-49
21	Hand Pulse Sensor	2	REV400-21	50	Crank	2	REV400-50
22	Pedal Soft Cushion	2	REV400-22	51	Crank Disk	2	REV400-51
23	Pedal	2	REV400-23	52	Belt	1	REV400-52
24	Pedal Support Base	2	REV400-24	53	M8 x 20mm CAP Bolt	1	REV400-53
25	Pedal Buffer Sets	2	REV400-25	54	Flywheel Assembly	1	REV400-54
26	Bearing 608zz	8	REV400-26	55	Bearing 6000zz	3	REV400-55
27	Bushing 8 x 12mm	4	REV400-27	56	Flywheel Axle	1	REV400-56
28	Pedal Fixing Base	2	REV400-28	57	Flywheel Shaft Fixing	1	REV400-57
29	Pedal Cover	2	REV400-29	58	Volute Bracket	1	REV400-58

PARTS LIST

No.	Description	Qty.	Order No.	No.	Description	Qty.	Order No.
59	Front Frame Cover - Upper	1	REV400-59	89	M10 Nylon Nut	2	REV400-89
60	Front Frame Cover - Lower	1	REV400-60	90	M12 Nut	1	REV400-90
61	Crank Disk Axle	1	REV400-61	91	ID 8mm Curve Washer	4	REV400-91
62	Crank Disk Support Bushing	2	REV400-62	92	10 x 22 x 2mm Washer	2	REV400-92
63	Bearing 6005zz	2	REV400-63	93	10 x 15 x 1.5mm	2	REV400-93
64	Bearing 6400zz	4	REV400-64	94	M4 x 40mm CAP Screw	1	REV400-94
65	Strengthen Wheel Adjusters Set	1	REV400-65	95	M4 x 19mm Hard Screw	32	REV400-95
66	Rear Stabilizer Cap	2	REV400-66	96	M4 x 19mm Screw	5	REV400-96
67	Rear Stabilizer Cushion	2	REV400-67	97	M4 x 12mm Screw	8	REV400-97
68	Caster	2	REV400-68	98	M10 Head Nut	2	REV400-98
69	Front Cover	1	REV400-69	99	Frame	1	REV400-99
70	Frame Outside Cover - Left	1	REV400-70	100	M4 x 50mm Bolt	1	REV400-100
71	Frame Inside Cover - Left	1	REV400-71	101	ID 10mm Curve Washer	2	REV400-101
72	Frame Inside Cover - Right	1	REV400-72	102	M4 x 15mm Hard Screw	8	REV400-102
73	Frame Outside Cover - Right	1	REV400-73	103	Upper Computer Wire	1	REV400-103
74	M8 x 15mm Allen Head Bolt	26	REV400-74	104	Lower Computer Wire	1	REV400-104
75	M8 x 20mm CAP Screws	2	REV400-75	105	M6 x 20mm Bolt	4	REV400-105
76	M8 x 90mm Allen Head Bolt	4	REV400-76	106	Lower Hand Pulse Wire	1	REV400-106
77	M8 x 60mm Allen Head Bolt	2	REV400-77	107	Water Bottle	1	REV400-107
78	M10 x 90mm Bolt	2	REV400-78				
79	M8 x 80mm Allen Head Bolt	2	REV400-79				
80	M8 x 15mm Bolt	6	REV400-80				
81	M10 x 45mm Allen Head Bolt	2	REV400-81				
82	M10 x 45mm Screw	2	REV400-82				
83	M6 x 20mm Allen Head Bolt	8	REV400-83				
84	M6 x 15mm Screw	4	REV400-84				
85	Fixing Inserts	12	REV400-85				
86	M6 Nylon Nut	8	REV400-86				
87	M8 Nylon Nut	5	REV400-87				
88	M14 Nut	2	REV400-88				

## PARTS DIAGRAM

A MAJORITY OF THE PARTS SHOWN HERE HAVE BEEN PREASSEMBLED AT THE FACTORY.

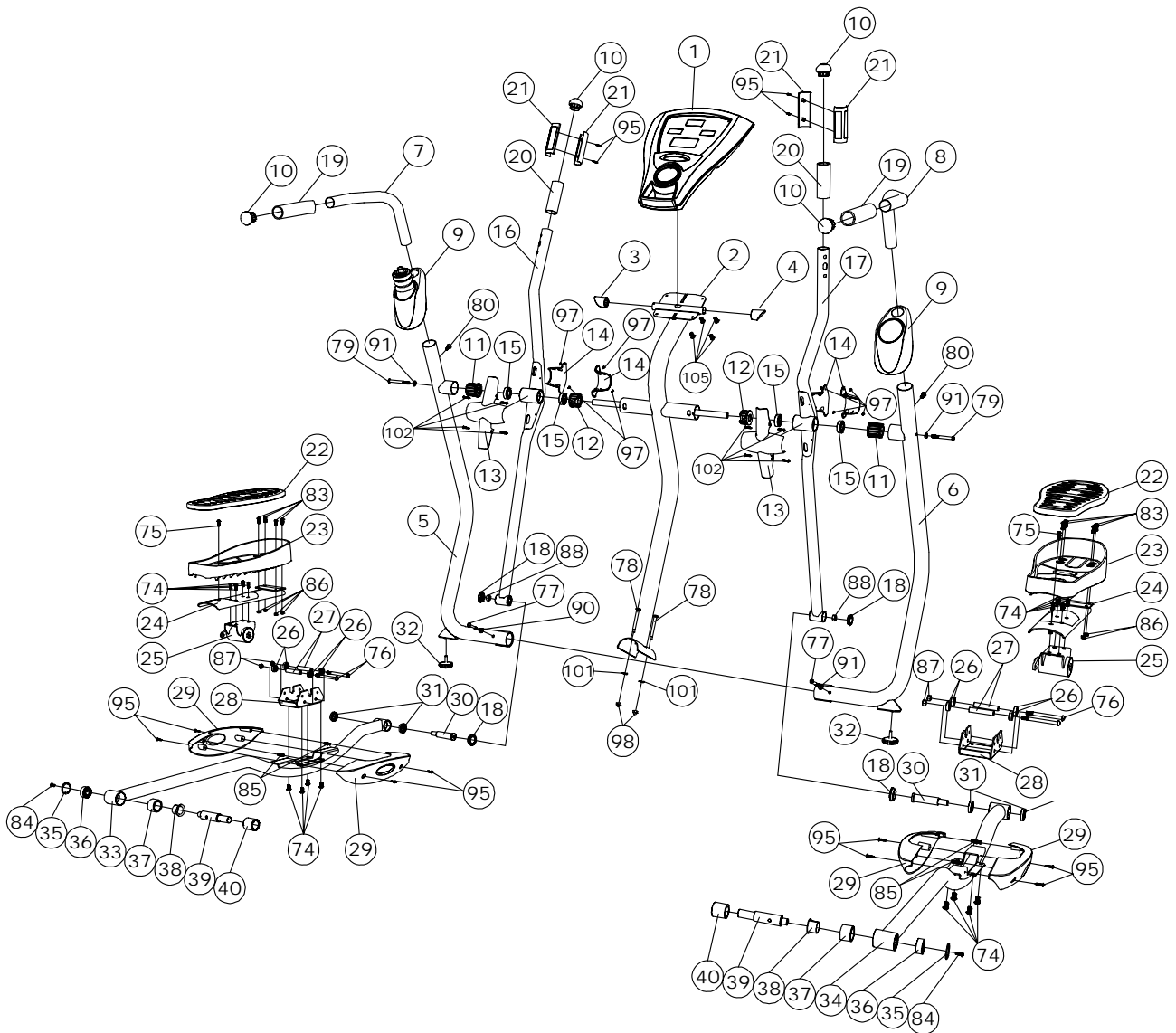

PARTS DIAGRAM

A MAJORITY OF THE PARTS SHOWN HERE HAVE BEEN PREASSEMBLED AT THE FACTORY.

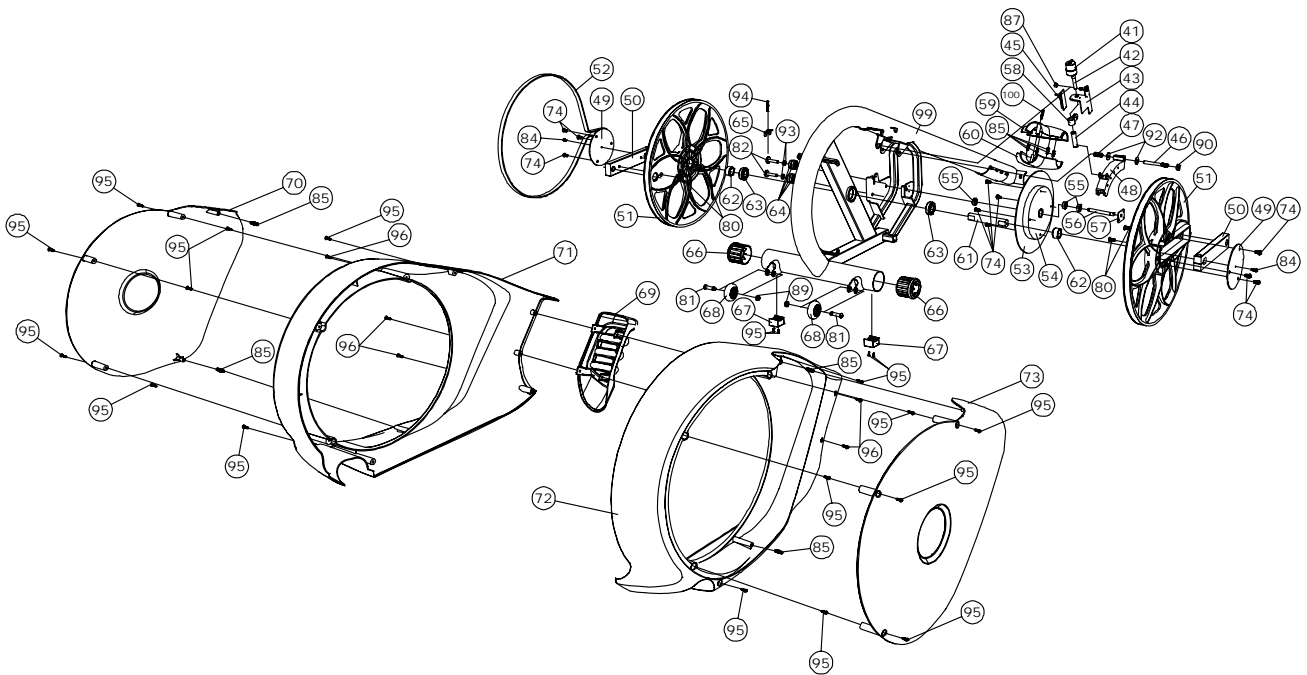



ASSEMBLY**STEP 1:**

**NOTE:** First make sure to connect the Upper Computer Wire (103) and Lower Computer Wire (104) as shown below. Attach the Front Upright Frame (2) to the Frame (99) and secure using the M10 x 90mm Bolts (78), ID 10mm Curve Washers (101) and M10 Head Nuts (98).

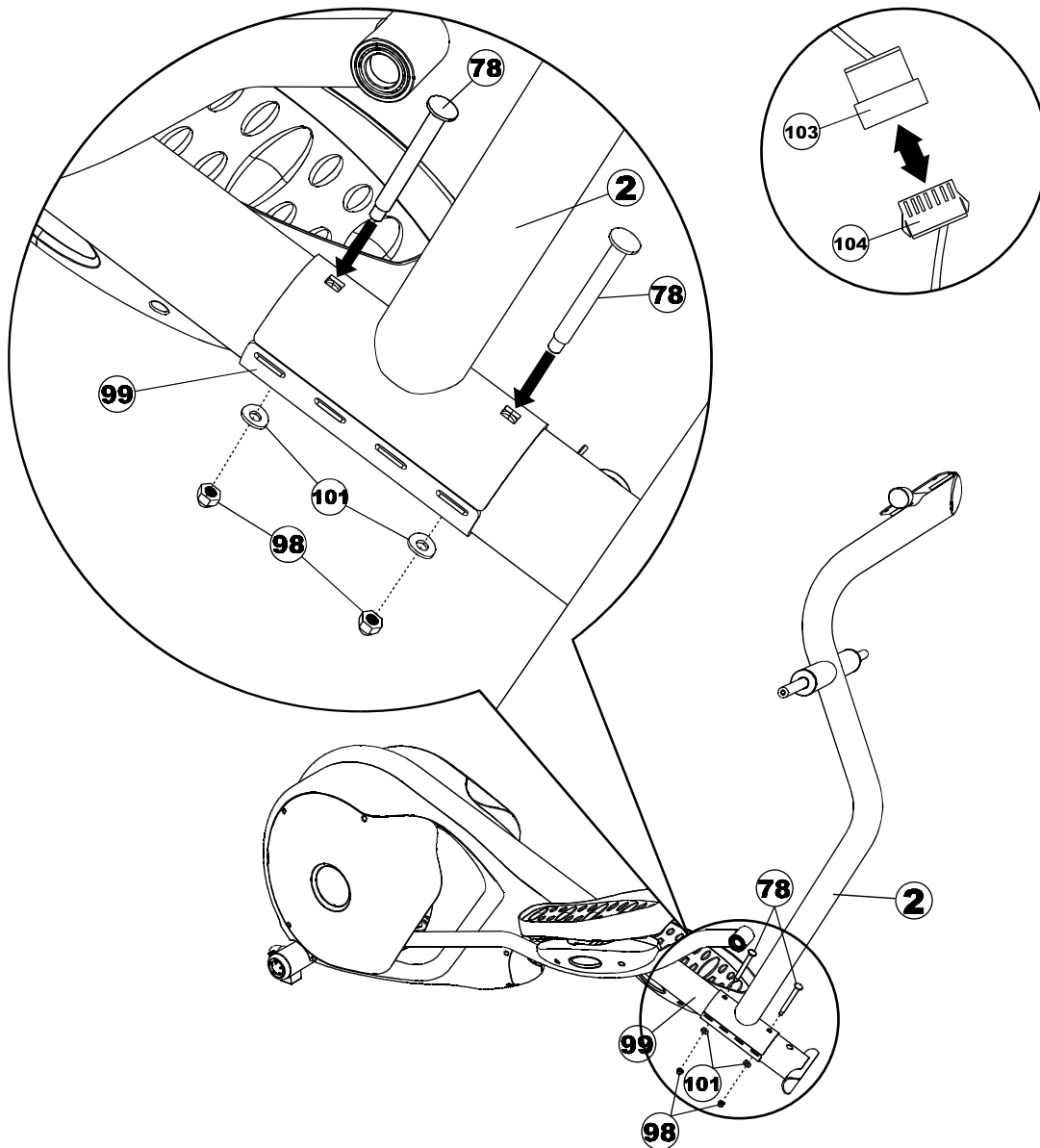

ASSEMBLY**STEP 2:**

NOTE: First make sure to connect the Upper Computer Wires (103) and Lower Hand Pulse Wires (106). Attach the Computer (1) to the Front Upright Frame (2) using four M6 x 20mm Bolts (105).

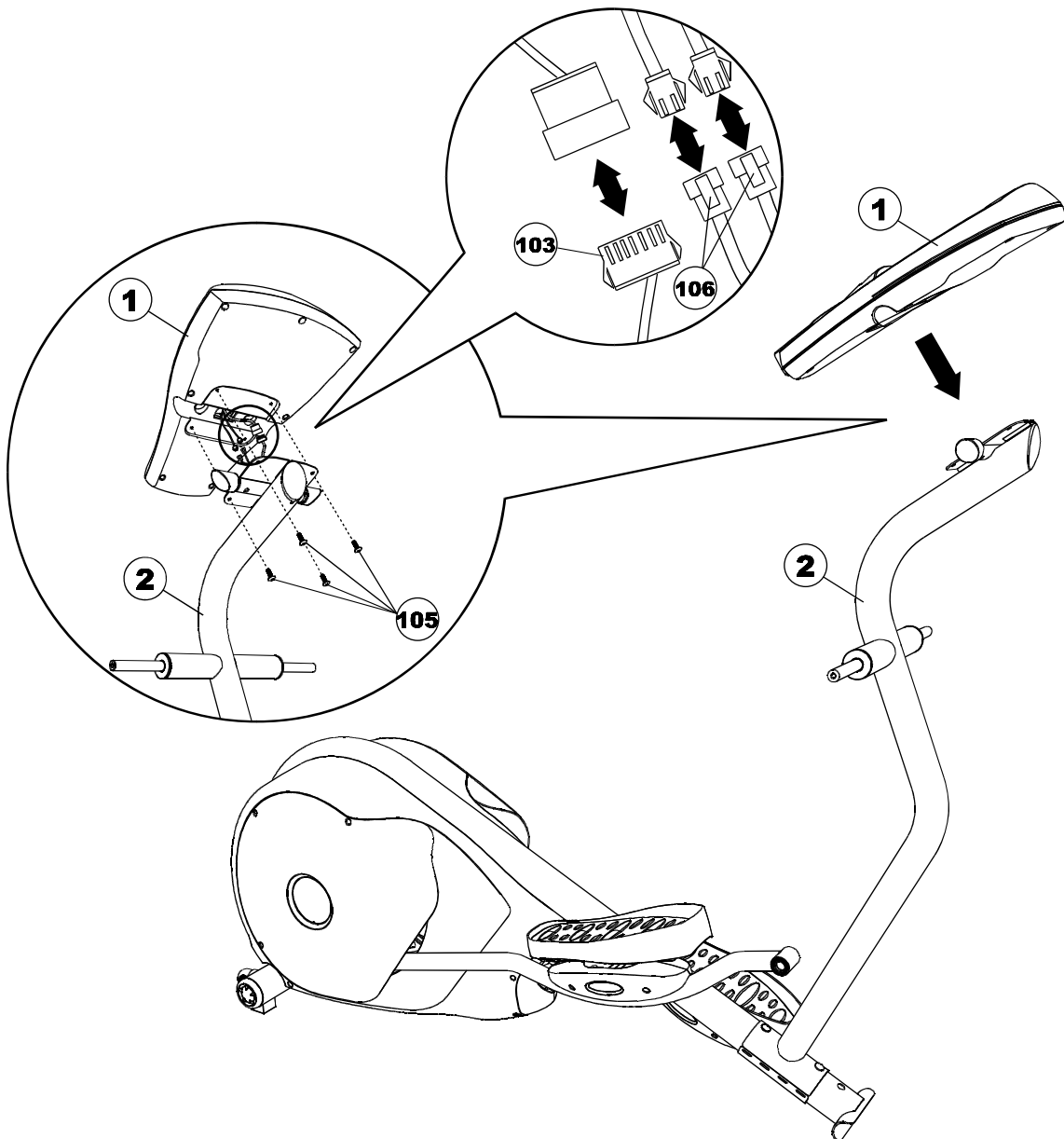

ASSEMBLY**STEP 3:**

NOTE: First make sure to connect the Hand Pulse Sensor Wires (21).  
Slide the Handlebar – Left (16) and Handlebar – Right (17) onto the Front Upright Frame (2).

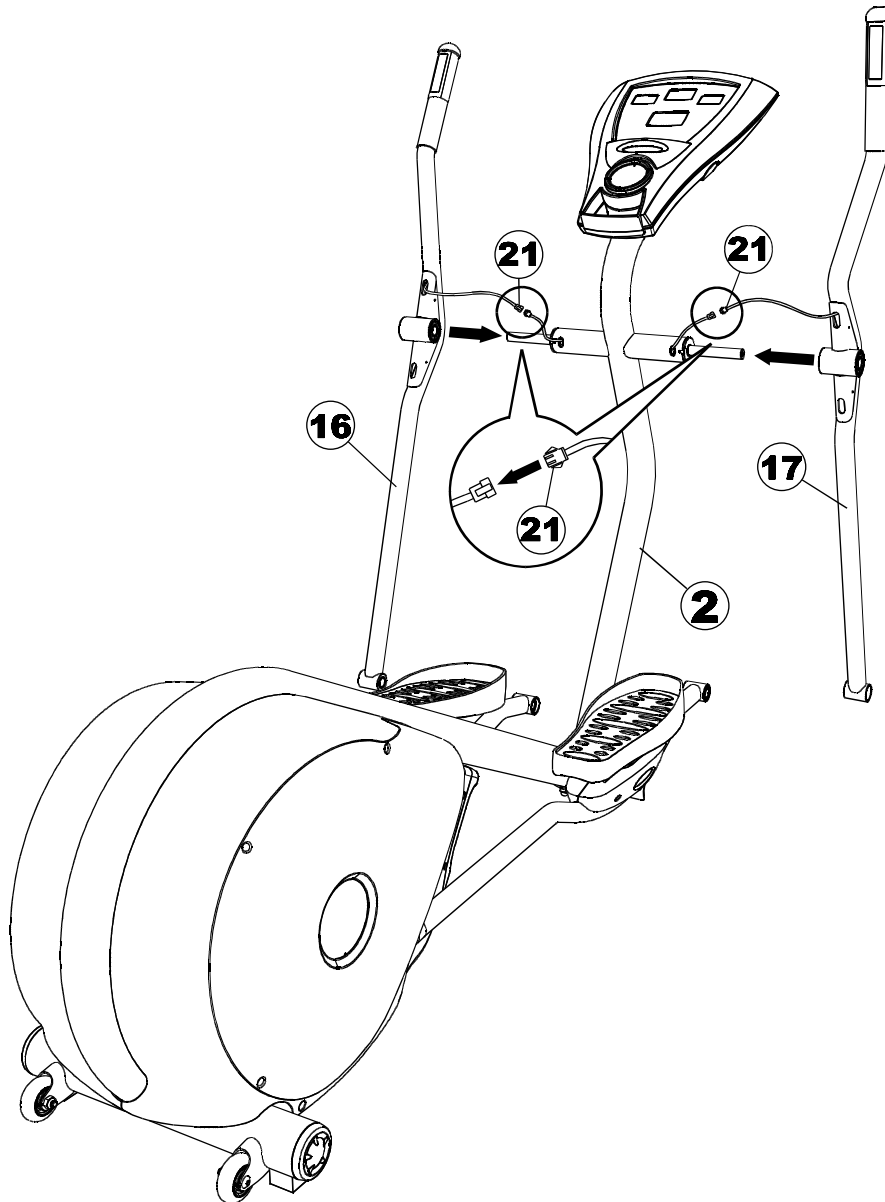

ASSEMBLY**STEP 4:**

Slide the Left Upright (5) on the Front Upright Frame (2) and secure it with an ID 8mm Curved Washer (91) and M8 x 80mm Allen Head Bolt (79). Repeat the procedure on the Right Upright (6).

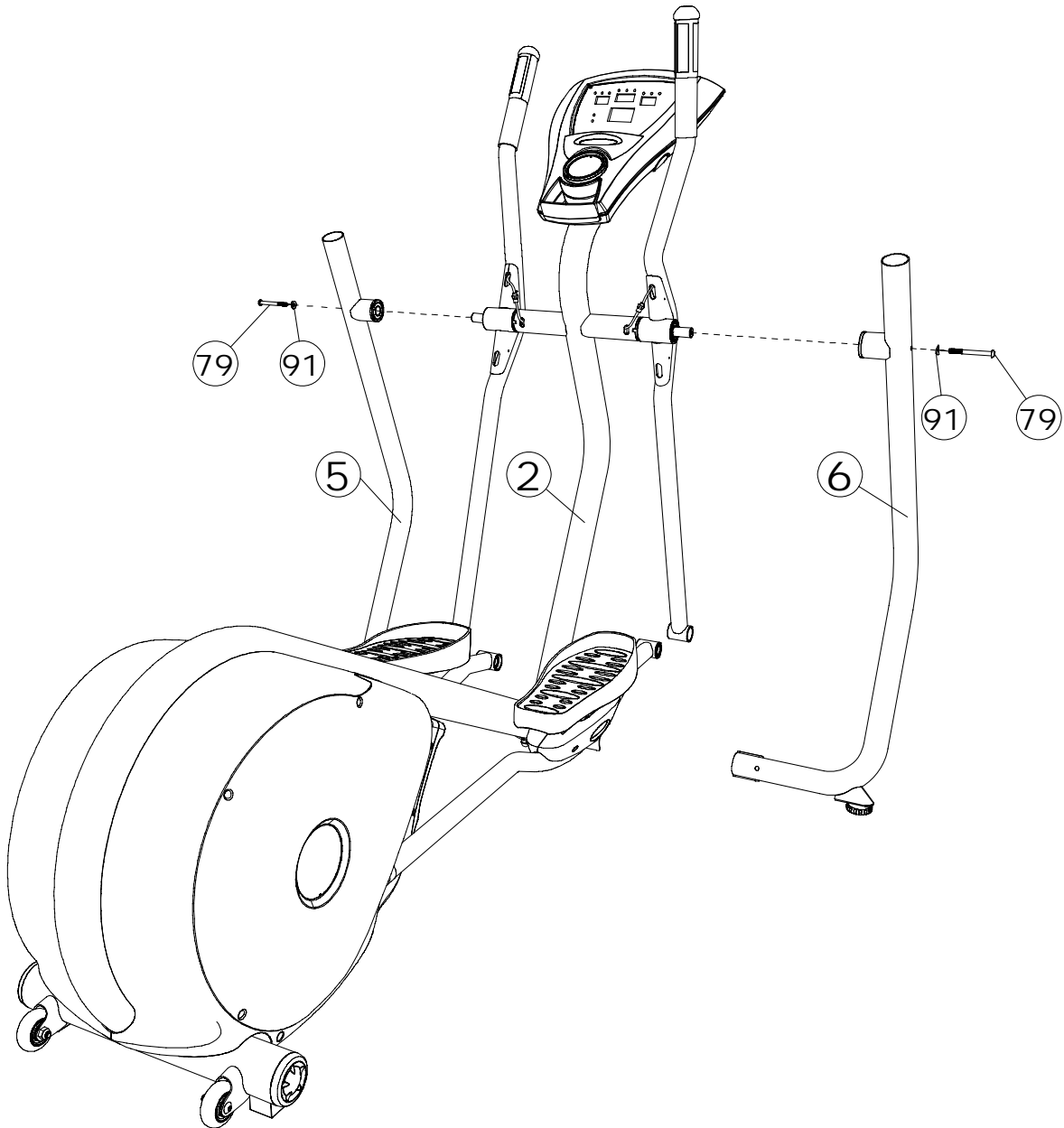

ASSEMBLY**STEP 5:**

Attach the Left Upright (5) and Right Upright (6) to the Frame (99) and secure using M8 x 60mm Allen Head Bolts (77) and ID 8mm Curve Washers (91).

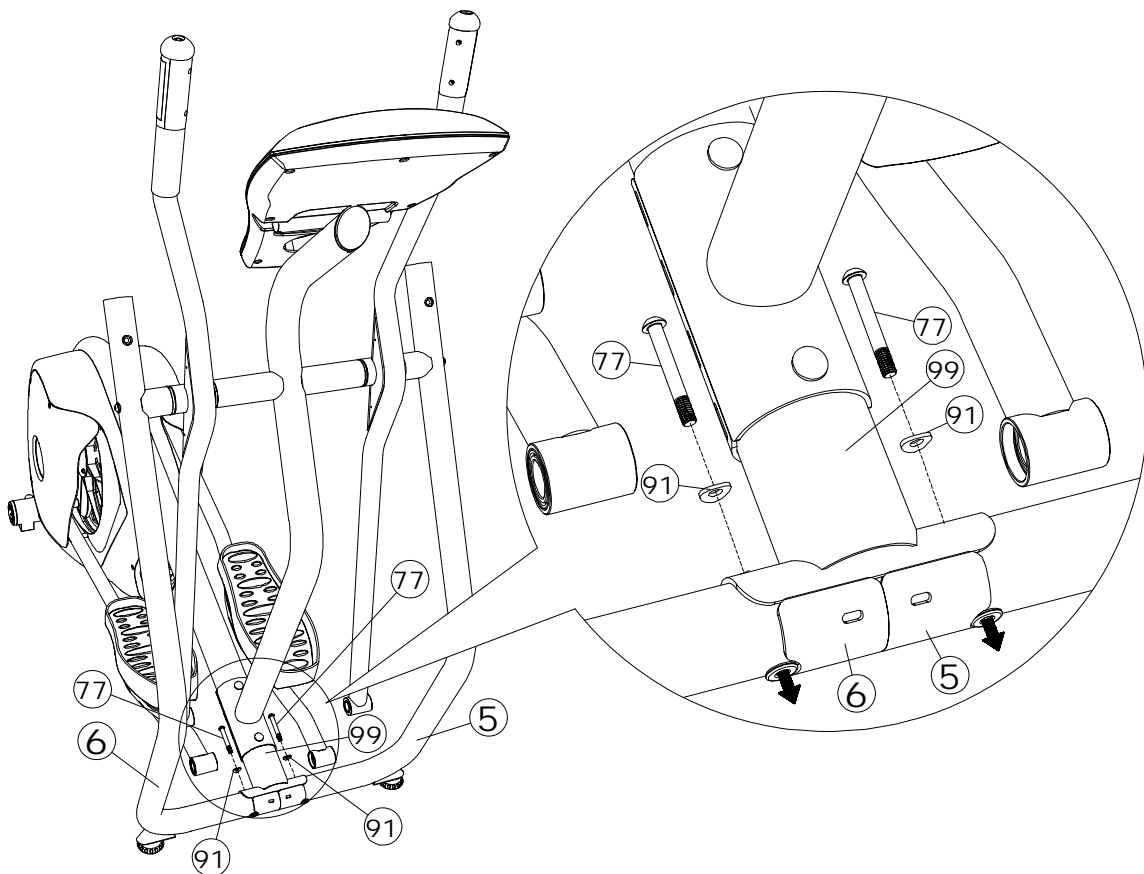

**ASSEMBLY****STEP 6:**

Slide the 20 x 91 x M14mm Bolt (30) through the Pedal Arm – Left (33) and Handlebar – Left (16) and secure with M14 Nut (88) using the 8mm Wrench (C), M14 Bushing Tool (A) and 5mm Allen Key (B) as shown.

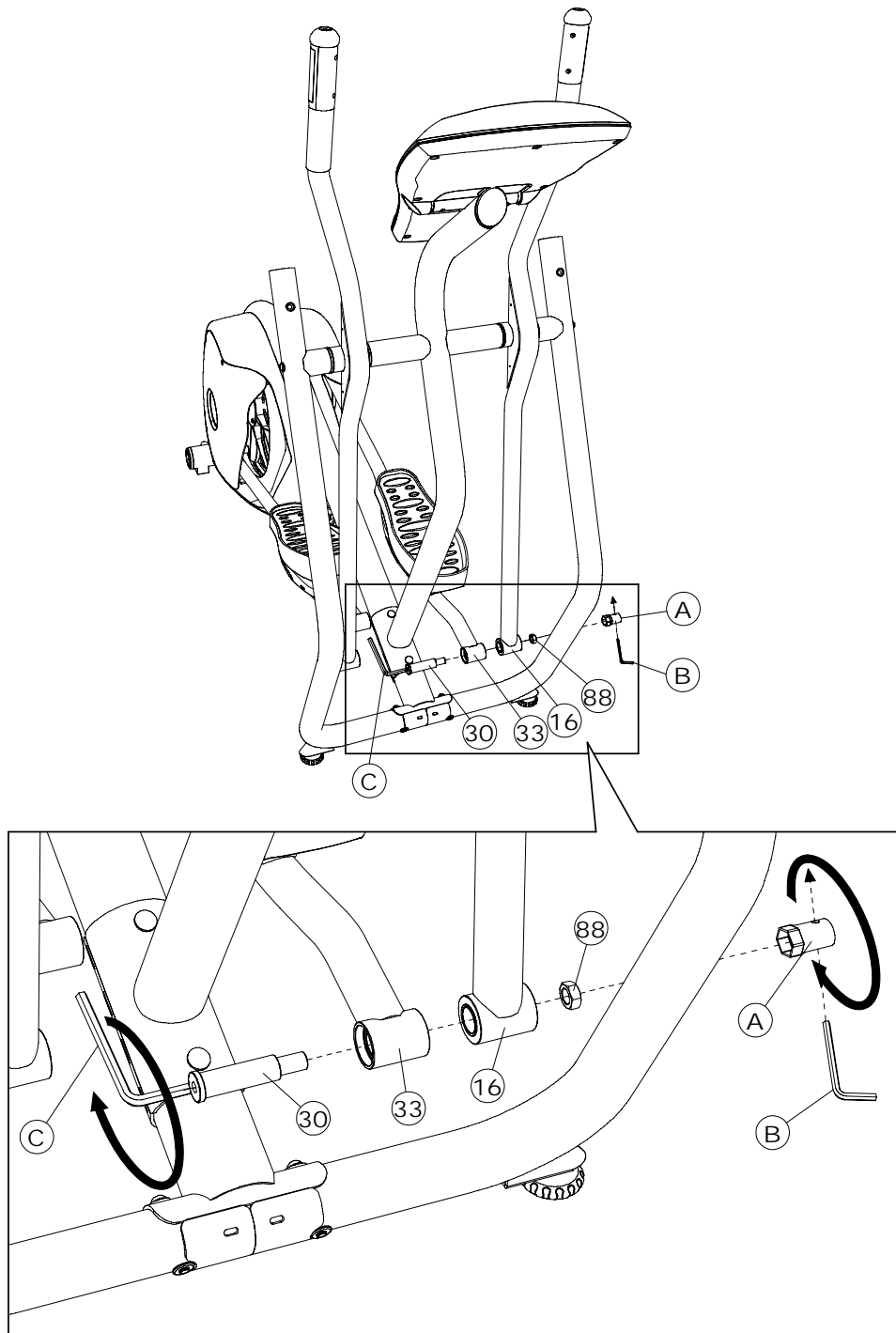

ASSEMBLY**STEP 7:**

Slide the 20 x 91 x M14mm Bolt (30) through the Pedal Arm – Right (34) and Handlebar – Right (17) and secure with M14 Nut (88) using the 8mm Allen Key (C), M14 Nut Bushing Tool (A) and 5mm Allen Key (B) as shown.

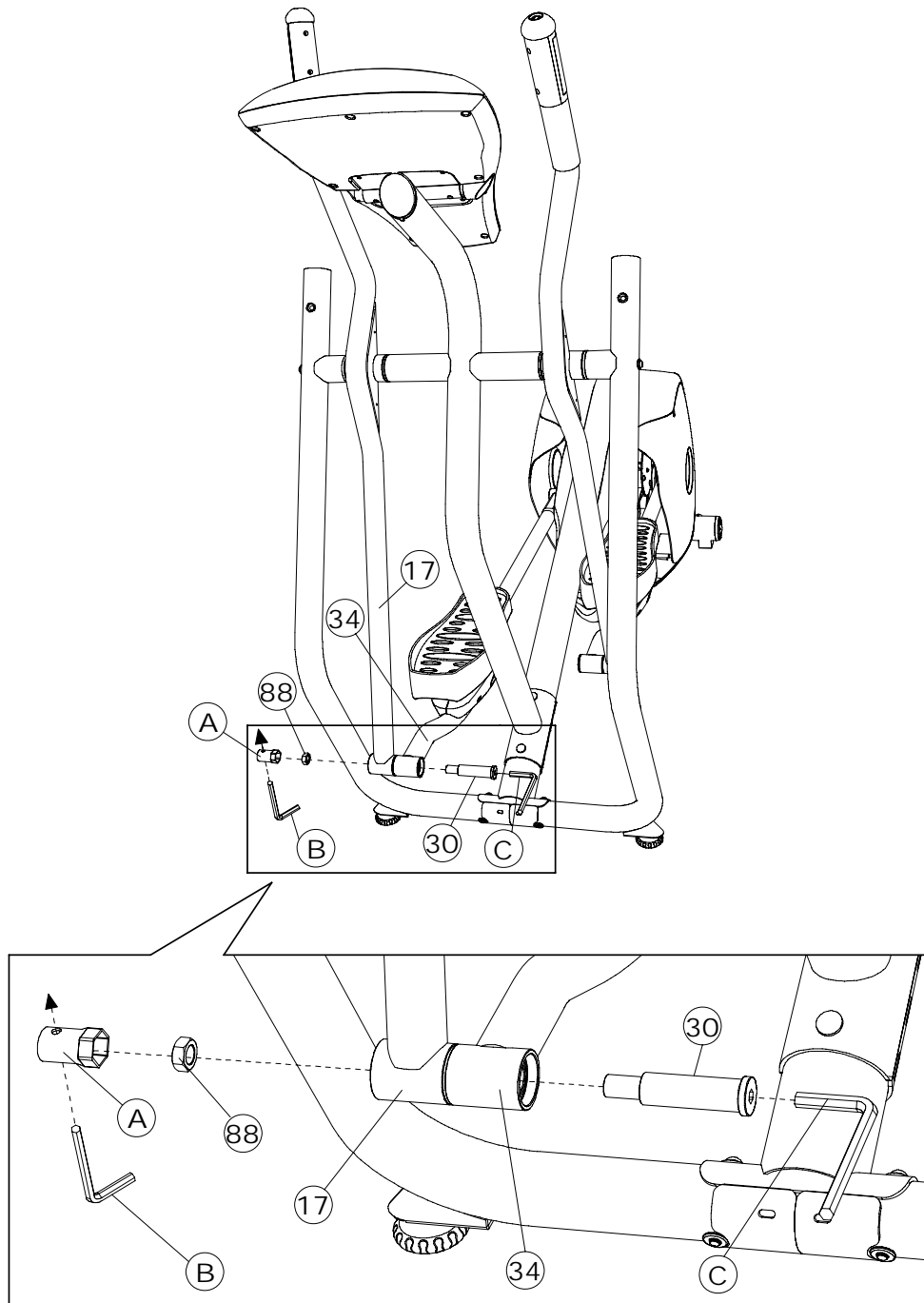

ASSEMBLY**STEP 8:**

Attach the Pedal Arm Front Pivot Cover (18) to the ends of the Handlebar – Right (17) and Pedal Arm – Right (34). Repeat the procedure on the Pedal Arm – Left (33) and Handlebar – Left (16).

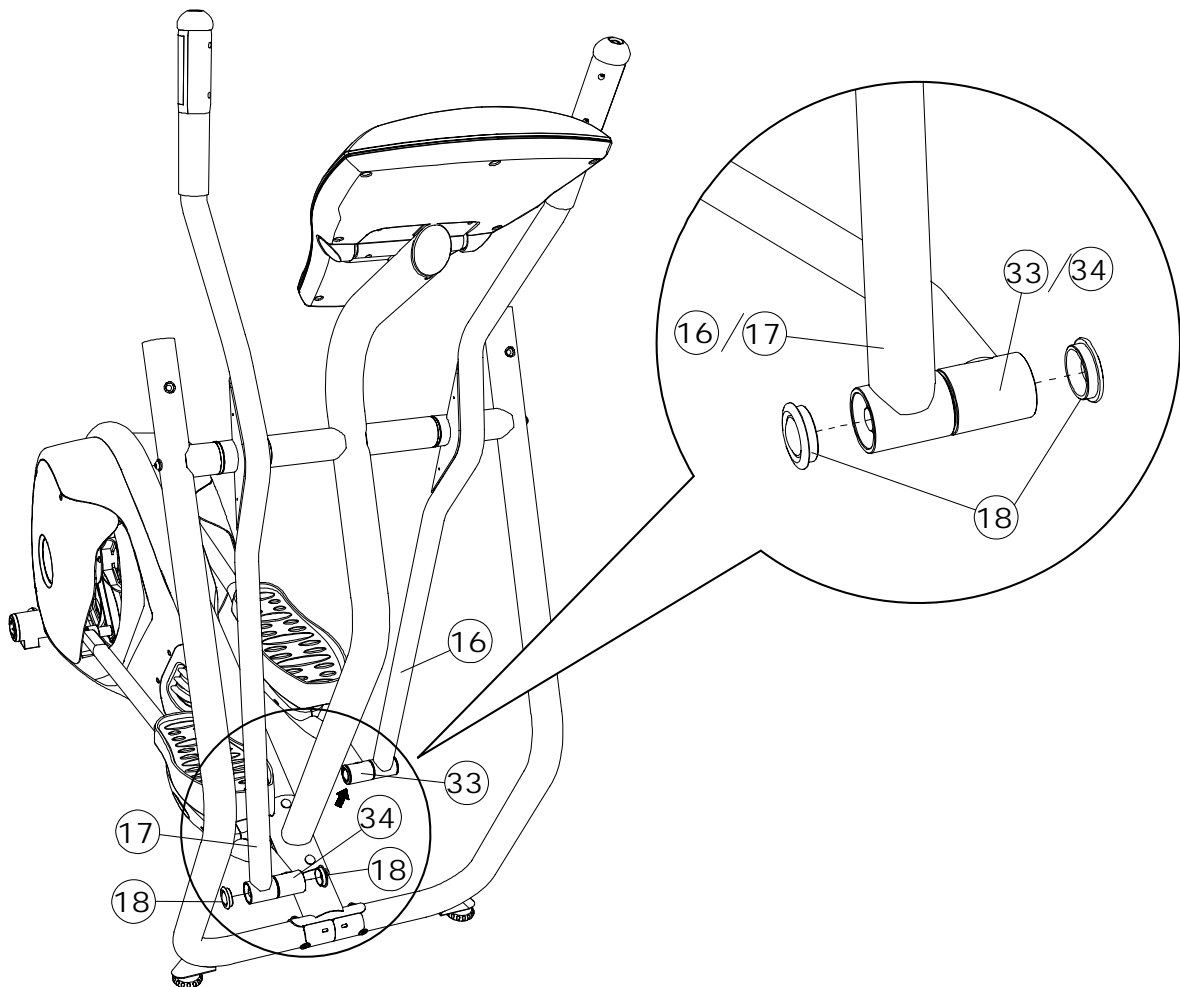



ASSEMBLY**STEP 9:**

Attach the Front Frame Cover – Upper (59) and Front Frame Cover – Lower (60) to the Left Upright (5), Right Upright (6) and Frame (99). Secure with Fixing Inserts (85) and M4 x 50mm Screw (100).

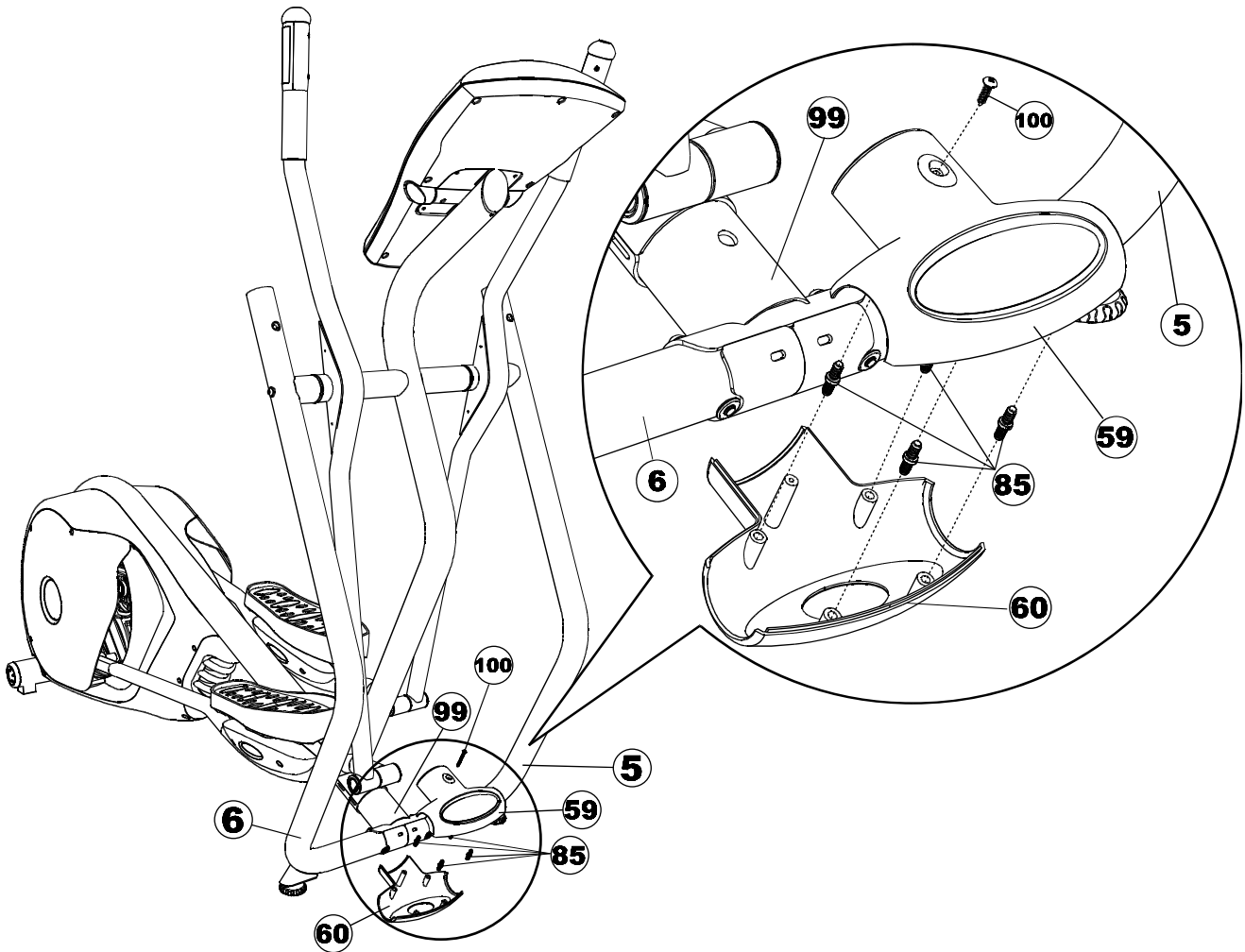

ASSEMBLY**STEP 10:**

Attach the Handlebar Cover (13) to the front side of the front side of the Handlebar – Right (17) and secure with M4 x 15mm Hard Screws (102). Then attach the Handlebar Inside Cover (14) to the backside of the Handlebar – Right (17) and secure it to the Handlebar Cover (13) using M4 x 12mm Screws (97). Repeat the procedure on the Handlebar – Left (16).

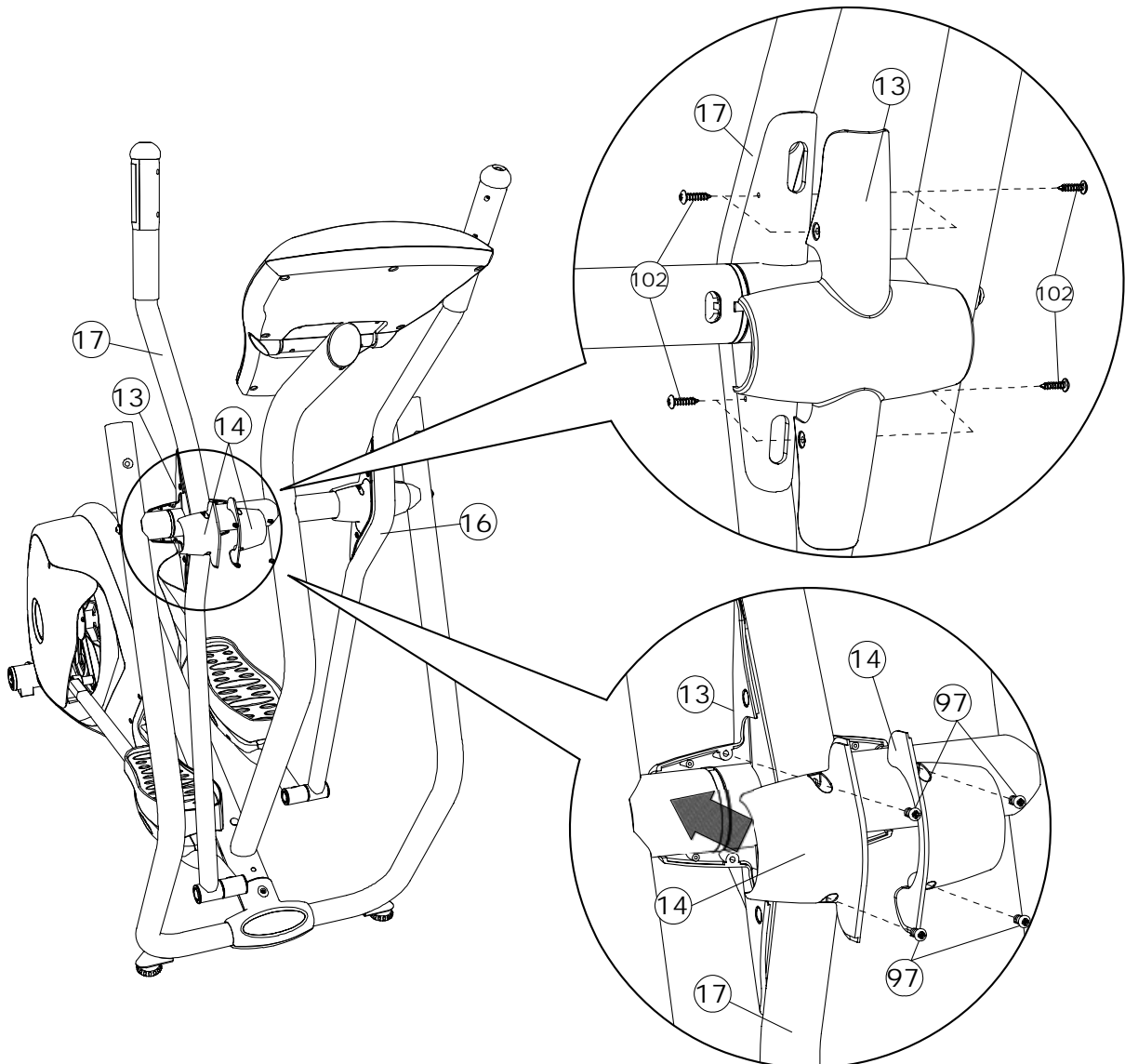

ASSEMBLY**STEP 11:**

Slide the Water Bottle Holders (9) onto the Right Upright (6) and Left Upright (5).

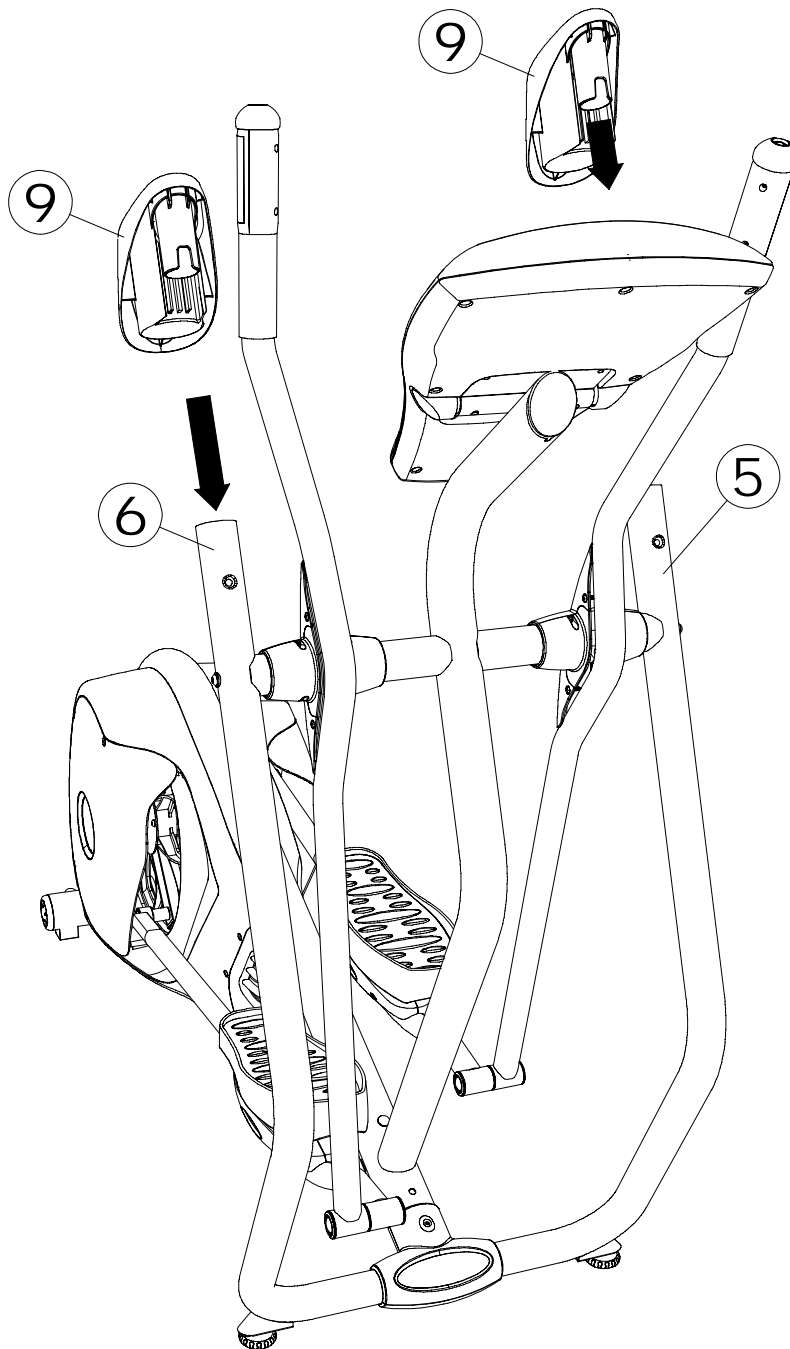

ASSEMBLY**STEP 12:**

Slide the Hand Rail Frame – Left (7) through the Water Bottle Holder (9) on the Left Upright (5) and secure with M8 x 15mm Bolt (80) as shown in FIG1. Repeat the procedure on the Right Upright (6).

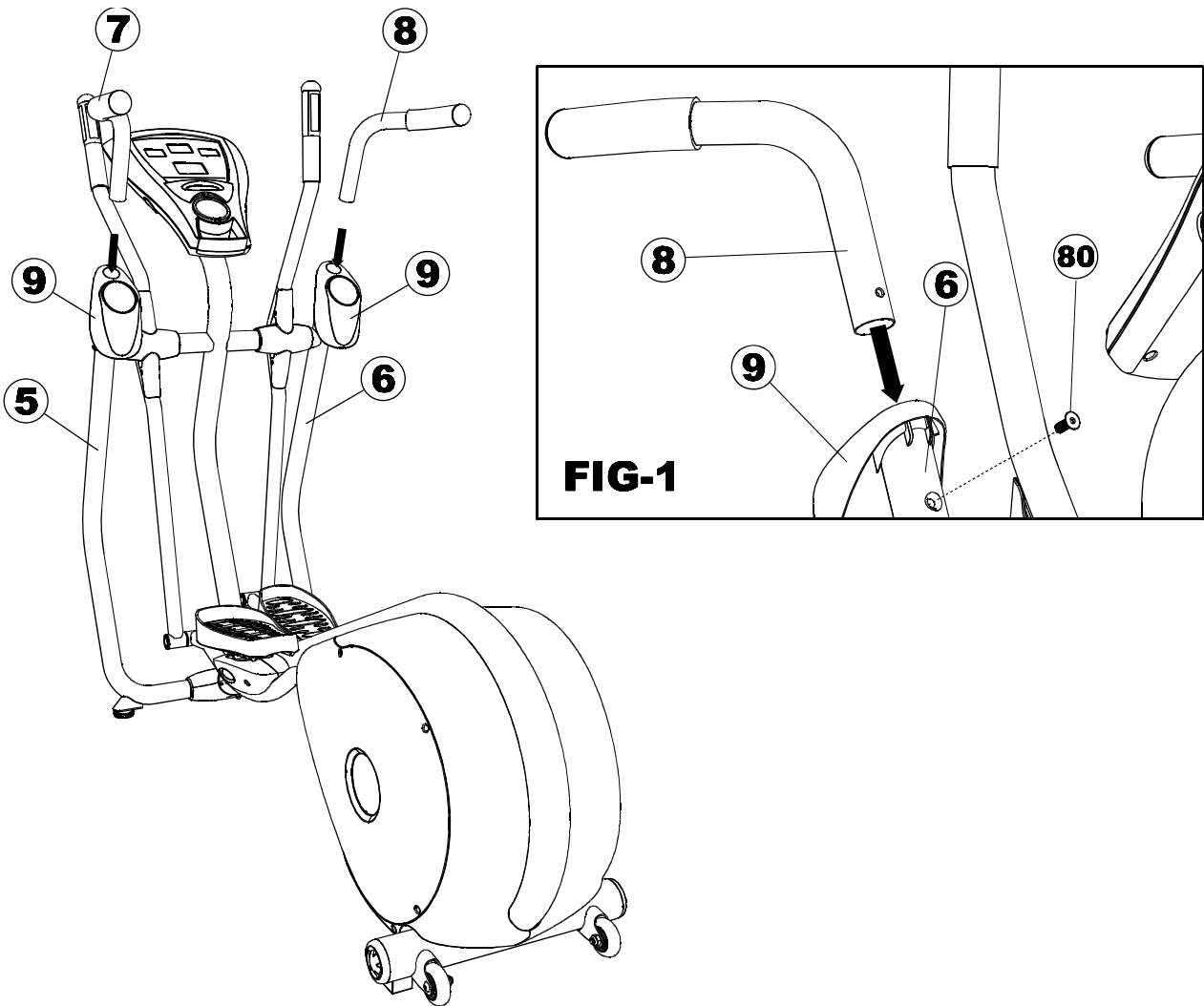

LEVEL ADJUSTMENT**LEVEL ADJUSTMENT:**

To adjust the level of the REV400 Elliptical Trainer simply rotate the Level Adjusters right or left to move them in or out of the Uprights.

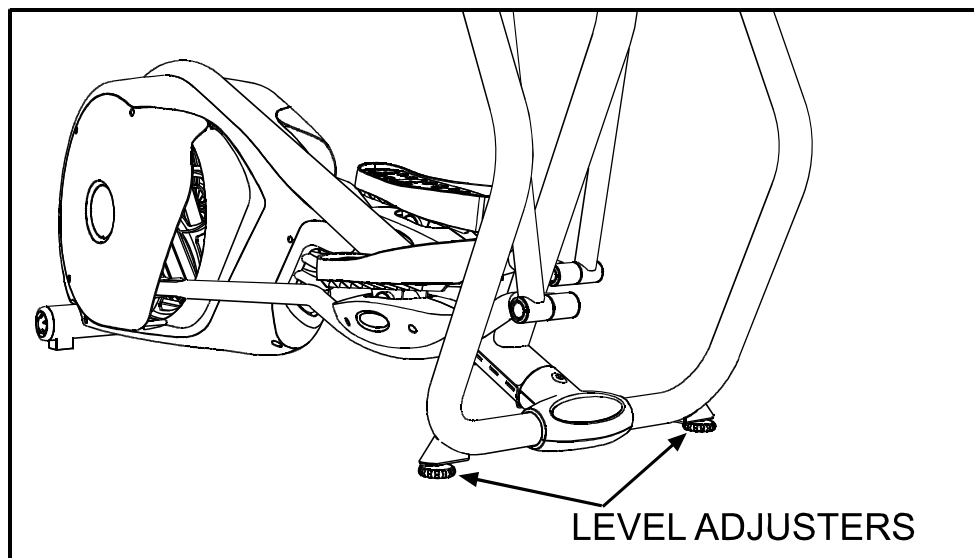

TRANSPORT INSTRUCTIONS**TRANSPORT INSTRUCTIONS:**

The casters located on the rear of the unit allow for easy transport. Simply lift the front of the unit until the wheels touch the floor. Then roll the unit to a desired location.

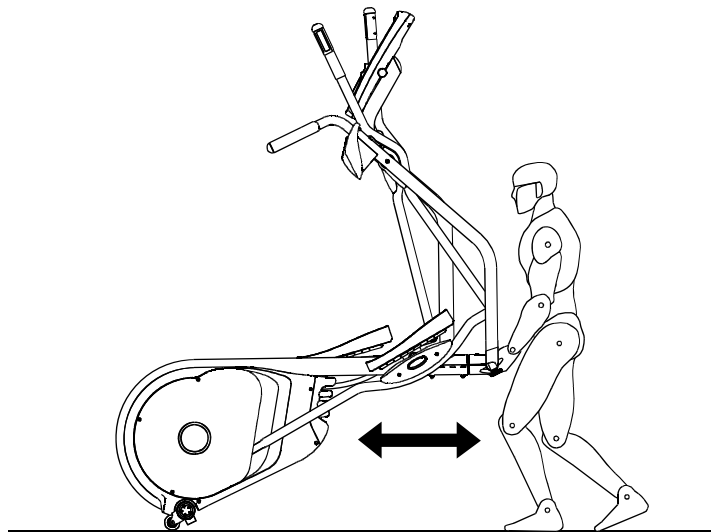
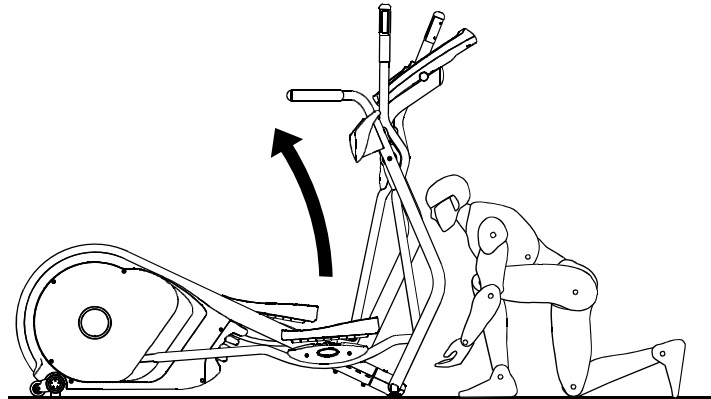

## COMPUTER INSTRUCTIONS

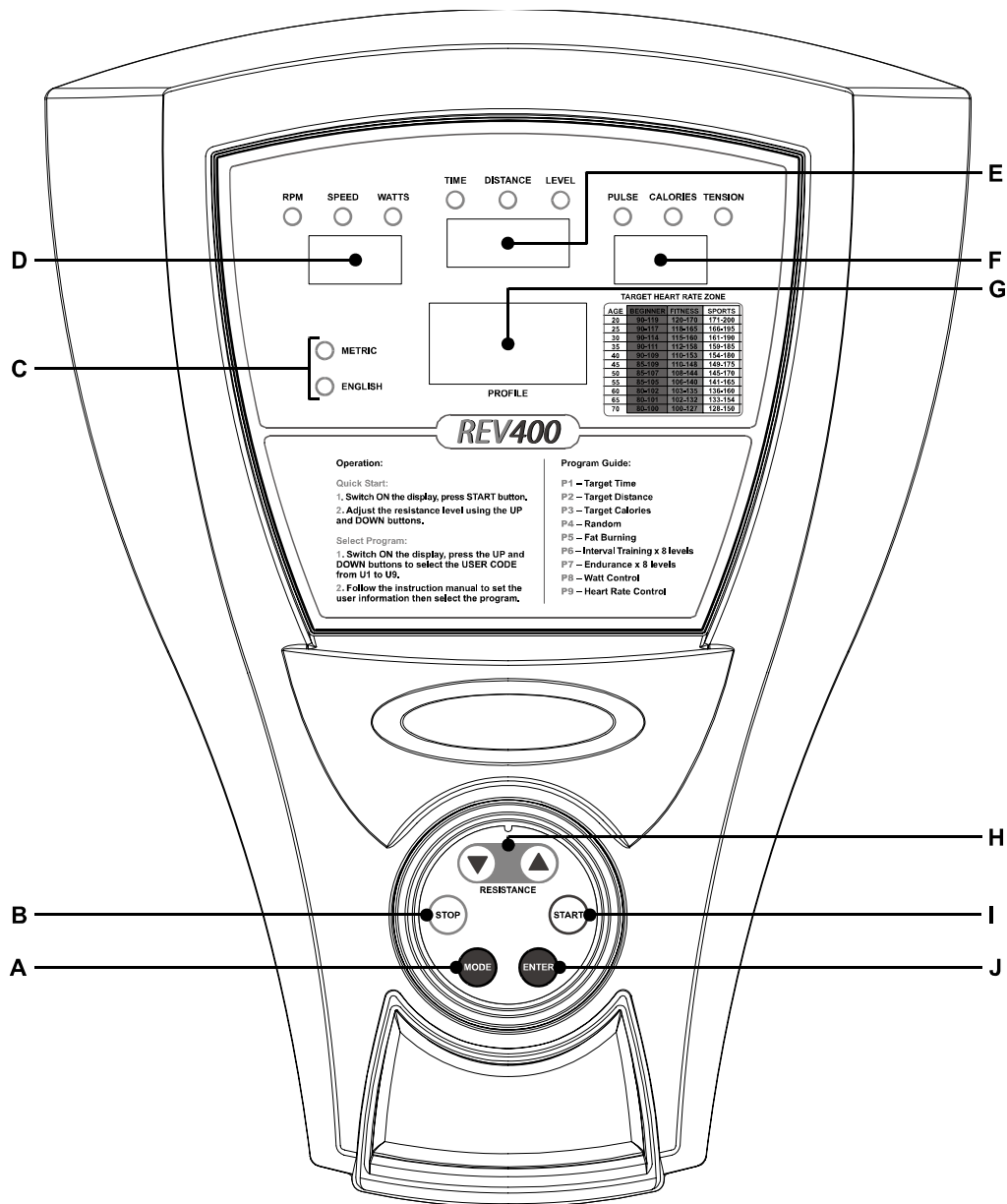

MODE Button	<b>A</b>	<b>B</b>	STOP Button
METRIC/ENGLISH Display	<b>C</b>	<b>D</b>	RPM/SPEED/WATTS Window
TIME/DISTANCE/LEVEL Window	<b>E</b>	<b>F</b>	PULSE/CALORIES/TENSION Window
PROFILE Window	<b>G</b>	<b>H</b>	DOWN/UP RESISTANCE Button
START Button	<b>I</b>	<b>J</b>	ENTER Button

## COMPUTER INSTRUCTIONS

### **FUNCTIONS AND BUTTONS**

**STOP:**

Press STOP to pause the functions during your exercise program. All the data on the display will freeze. Press START to resume the program and all the data displayed will continue until the program has finished.

**START:**

Press START to begin your exercise.

**ENTER:**

Press ENTER to confirm the setting of program.

**MODE:**

Press MODE to switch the display to show the information as RPM/TIME/PULSE or SPEED/DISTANCE/CALORIES or WATTS/LEVEL/TENSION (RESISTANCE).

**RESISTANCE UP/DOWN:**

Press UP/DOWN buttons to adjust the resistance.

**SPEED:**

Displays current exercise speed by Km/h or MPH

**LEVEL:**

Displays the current level of intensity of your exercise program.

**CALORIES:**

Count up: this measures total calories burned during exercise.

Count down: if you have set the number of calories, the computer will count down from that preset number down to zero. This data is a guide and should not be used for medical assessment. Please note when setting a target this is in blocks of 10 from 0 to 990.

**TENSION (RESISTANCE):**

Displays the current tension (resistance) level from 1 to 16.

**DISTANCE:**

Count up: this measures the total distance from 0 to 99.9 Km / Mile.

Count down: if you have set the target distance, the computer will count down from that preset distance down to zero as soon as you start exercising.

**WATT:**

This displays your current wattage output. Watts are displayed from 110W to 350W Please note do not set below 110Watts.

**TIME:**

Count up: the computer measures total exercise time from 00:00 up to 99:00.

Count down: if you have set the target time, the computer will count down from that preset time down to 0:00.

**HEART RATE:**

This displays your current Heart Rate; you will need to be wearing the chest strap in order for this to be displayed.

**QUICK START:**

When the bike is in the POWER ON status, press the START button to activate the QUICK START program. The TIME, DISTANCE and CALORIES will count up when you start exercising.

**PROGRAM:**

To select one of the User programs, you will need to select the USER CODE first. Press the UP/DOWN button to select the USER CODE from U1 to U9. This is shown in the PROFILE display. Press the ENTER button to confirm the user code. If the user information has been previously input, press ENTER and hold for 3 seconds, the computer will then skip the user information set up procedure and enter the program select procedure. To input new information, please follow the procedure below:



## COMPUTER INSTRUCTIONS

**HEIGHT** set up – After the User Code has been confirmed the USER HEIGHT display will show 170cm/67 inches or the previous setting and begin flashing. Press the UP/DOWN button to adjust the user height information, then press ENTER to confirm.

**WEIGHT** set up – After the HEIGHT has been confirmed the USER WEIGHT display will show 68kg/150lbs or the previous setting and begin flashing. Press the UP/DOWN button to adjust the user weight information, then press ENTER to confirm.

**AGE** set up – After the WEIGHT has been confirmed the USER AGE display will show 35 or the previous setting and begin flashing. Press the UP/DOWN button to adjust the user age information then, press ENTER to confirm.

### **P1 TO P9 PROGRAMS SELECTING PROCEDURE**

After setting the USER AGE press ENTER to confirm. Alternatively just press ENTER and hold for 3 seconds after power on. The PROFILE display will show P1 flashing. Press the UP/DOWN button, to scroll through P1 to P9, press ENTER to confirm the program.

#### **P1: TARGET TIME**

After you have selected P1 TARGET TIME, the TIME display will show the default time setting of 32:00 minutes. Press the UP/DOWN button to adjust target time then press ENTER to confirm. Press START to begin the exercise program.

To increase or decrease the resistance whilst exercising, press the UP/DOWN button.

To pause the program whilst exercising, press the STOP button. To resume exercising, press the START button.

If the STOP button is pressed after pausing the program, the computer returns to Power on Status.

#### **P2: TARGET DISTANCE**

After you have selected P2 TARGET DISTANCE, the DISTANCE display will show the default distance setting of 5.0 km/miles. Press the UP/DOWN button to adjust target distance then press ENTER to confirm. Press START to begin the exercise program.

To increase or decrease the resistance whilst exercising, press the UP/DOWN button.

To pause the program while exercising, press the STOP button. To resume exercising, press the START button.

If the STOP button is pressed after pausing the program, the computer returns to Power on Status.

#### **P3: TARGET CALORIES**

After you have selected P3 TARGET CALORIES, the CALORIES display will show the default calories setting 50. Press the UP/DOWN button to adjust target calories then press ENTER to confirm. Press START to begin the exercise program.

To increase or decrease the resistance whilst exercising, press the UP/DOWN button.

To pause the program whilst exercising, press the STOP button. To resume exercising, press the START button.

If the STOP button is pressed after pausing the program, the computer returns to Power on Status.

#### **P4: RANDOM**

After you have selected P4 RANDOM, the TIME display will show the workout time setting of 32:00 minutes. Press the UP/DOWN button to adjust workout time then press ENTER to confirm. Press START to begin the exercise program. The RANDOM program has 50 different RESISTANCE based programs. If whilst exercising, you find the level of RESISTANCE too intense you can press the UP/DOWN button to decrease the resistance.

COMPUTER INSTRUCTIONS

To pause the program whilst exercising, press the STOP button. To resume exercising, press the START button.

If the STOP button is pressed after pausing the program, the computer returns to Power on Status.

**P5: FAT BURNING**

After you have selected P5 FAT BURNING, the TIME display will show the default workout time setting of 32:00 minutes. Press the UP/DOWN button to adjust workout time then press ENTER to confirm. Press START to begin the exercise program.

The aim of a FAT BURNING program is to exercise for a longer period of time at a reduced level of intensity. This will allow you to burn more calories than if you were using a program that has higher levels of resistance over a shorter period of time.

**Please note:** on this particular program once the highest level of resistance is set, the resistance cannot be decreased whilst exercising. To decrease the resistance you will need to stop the program and start again.

To pause the program whilst exercising, press the STOP button. To resume exercising, press the START button.

If the STOP button is pressed after pausing the program, the computer returns to Power on Status.

Fat Burning Profile: (If user sets workout time above 16 minutes, the computer will average the workout time in 16 sections as following "Resistance Profile", i.e. input 32 minutes, the computer will do 2 minutes each section.

If user set the workout time less than 16 minutes, the computer will run one minute for one section till time out, i.e. input 12 minutes, the computer will just do 12 sections.).

Resistance																
1	3	7	9	9	9	9	9	9	9	9	9	9	9	7	3	1

**P6: INTERVAL**

After you have selected P6 INTERVAL, the TIME display will show the default workout time setting of 32:00 minutes. Press the UP/DOWN button to adjust workout time then press ENTER to confirm. Press START to begin the exercise program. The aim of an INTERVAL program is to exercise at levels of LOW and HIGH intensity for short periods of time. There is one profile with 8 different levels of Intensity. The resistance will be changed automatically whilst exercising, according to the following profile.

To increase or decrease the resistance whilst exercising, press the UP/DOWN button.

To pause the program whilst exercising, press the STOP button. To resume exercising, press the START button.

If the STOP button is pressed after pausing the program, the computer returns to Power on Status.

COMPUTER INSTRUCTIONS

Interval Profile: (If user sets workout time above 16 minutes, the computer will average the workout time in 16 sections as following "Resistance Profile", i.e. input 32 minutes, the computer will do 2 minutes each section.

If user set the workout time less than 16 minutes, the computer will run one minute for one section till time out, i.e. input 12 minutes, the computer will just do 12 sections.).

Levels	Resistance															
1	1	9	9	1	1	9	9	1	1	9	9	1	1	9	9	1
2	2	10	10	2	2	10	10	2	2	10	10	2	2	10	10	2
3	3	11	11	3	3	11	11	3	3	11	11	3	3	11	11	3
4	4	12	12	4	4	12	12	4	4	12	12	4	4	12	12	4
5	5	13	13	5	5	13	13	5	5	13	13	5	5	13	13	5
6	6	14	14	6	6	14	14	6	6	14	14	6	6	14	14	6
7	7	15	15	7	7	15	15	7	7	15	15	7	7	15	15	7
8	8	16	16	8	8	16	16	8	8	16	16	8	8	16	16	8

COMPUTER INSTRUCTIONS**P7: ENDURANCE**

After you have selected P7 ENDURANCE, the TIME display will show the default workout time of setting 32:00 minutes. Press the UP/DOWN button to adjust workout time then press ENTER to confirm. Press START to begin the exercise.

The aim of an ENDURANCE program is to start at a low level of resistance and then at ever increasing higher levels of resistance in order that the body exercises at higher levels of intensity. The profile ends with a lower level of intensity to reduce the Heart rate. There is one profile with 8 levels of Intensity. The resistance will be changed automatically whilst exercising, according to the following profile.

To increase or decrease the resistance whilst exercising, press the UP/DOWN button.

To pause the program whilst exercising, press the STOP button. To resume exercising, press the START button.

If the STOP button is pressed after pausing the program, the computer returns to Power on Status.

Endurance Profile: (If user sets workout time above 16 minutes, the computer will average the workout time in 16 sections as following "Resistance Profile", i.e. input 32 minutes, the computer will do 2 minutes each section.

If user set the workout time less than 16 minutes, the computer will run one minute for one section till time out, i.e. input 12 minutes, the computer will just do 12 sections.).

Levels	Resistance															
1	1	1	3	3	4	4	5	5	6	6	7	7	9	9	1	1
2	2	2	4	4	5	5	6	6	7	7	8	8	10	10	2	2
3	3	3	5	5	6	6	7	7	8	8	9	9	11	11	3	3
4	4	4	6	6	7	7	8	8	9	9	10	10	12	12	4	4
5	5	5	7	7	8	8	9	9	10	10	11	11	13	13	5	5
6	6	6	8	8	9	9	10	10	11	11	12	12	14	14	6	6
7	7	7	9	9	10	10	11	11	12	12	13	13	15	15	7	7
8	8	8	10	10	11	11	12	12	13	13	14	14	16	16	8	8

**P8: WATT CONTROL**

After you have selected the P8 WATT CONTROL program, the WATT display will show the default workout watt setting 110W. Press the UP/DOWN button to adjust workout watts then press ENTER to confirm. Then the TIME display will show the default workout time setting 32:00 minutes. Press the UP/DOWN button to adjust workout time then press ENTER to confirm. Press START to begin the exercise program.

The resistance will be changed automatically whilst exercising. The program will change the resistance automatically to match the user watts setting.

To increase or decrease the resistance whilst exercising, press the UP/DOWN button.

To pause the program whilst exercising, press the STOP button. To resume exercising, press the START button.

If the STOP button is pressed after pausing the program, the computer returns to Power on Status.

## COMPUTER INSTRUCTIONS

### **P9: TARGET HEART RATE**

After you have selected P9 TARGET HEART RATE, The PULSE display will show the Target Heart Rate base on your age. Your Target Heart Rate has been set whilst you were setting USER AGE up with a user number e.g. U1 to U9. Please note the user TARGET HEART RATE will be adjusted with the user AGE according to the factory setting. The factory TARGET HEART RATE setting is based on 85% of the maximum heart rate. The maximum heart rate is calculated as 220 minus the user age. For a 35-year old, the maximum user heart rate should be 185 and 85% of user heart rate. If you wish to alter your Target Heart Rate, press the UP/DOWN button to adjust the TARGET HEART RATE. Then the TIME display will show the default workout time of setting 32:00 minutes. Press the UP/DOWN button to adjust workout time then press ENTER to confirm. Press START to begin the exercise program.

**NOTE: Please always consult your doctor to your proper workout target heart rate.**

To increase or decrease the resistance whilst exercising, press the UP/DOWN button.

To pause the program whilst exercising, press the STOP button. To resume exercising, press the START button.

If the STOP button is pressed after pausing the program, the computer returns to Power on Status.

### **WARM UP – TARGET HEART RATE**

After completing the TIME set up and starting the program, there is a 3 minute WARM UP program to help you reach the minimum target workout heart rate. The resistance will start from 2. If the actual user's pulse does not reach 65% of the maximum heart rate  $((220 - \text{age}) \times 65\%)$ , the resistance will increase one level every 15 seconds. The computer will detect user heart rate per 15 seconds. When the computer detects 2 times that actual pulse rate reaches the minimum target workout heart rate, the resistance will stop increasing and continue at the same resistance until the 3 minute warm up is complete and then go into the HEART RATE CONTROL main program.

If you cannot reach the minimum target workout heart rate in 3 minutes, the program will continue the second 3 minute WARM UP program. If during the second WARM UP the user still cannot reach the minimum target workout heart rate, the computer will continue on to the third WARM UP procedure for 3 minutes. If the third WARM UP program still cannot bring up the actual pulse rate to the minimum target workout heart rate, the program will stop and TIME display will show FAIL.

### **HEART RATE CONTROL MAIN PROGRAM**

After the actual pulse rate reaches the minimum target workout heart rate and completes the warm up program, the computer will go into the main program and the time will count down from the pre-set time. During the main program, the computer will detect the user heart rate per 15 seconds. If the actual pulse rate cannot reach the Target Heart Rate, the resistance level will be increased by 1 level every 15 seconds until the pulse rate reaches the Target Heart Rate or the resistance level will increase by 16 levels. If the actual pulse is higher than the Target Heart Rate, then the resistance will be reduced 1 level every 15 seconds until the actual heart rate meets the Target Heart Rate. If the actual pulse is higher than the Target Heart Rate over 3 minutes, the computer would stop HEART RATE CONTROL program then begin the COOL DOWN function.

### **COOL DOWN – TARGET HEART RATE**

After completing the HEART RATE CONTROL program and the time counts down to zero start the one-minute Cool Down program. The TIME display will show 'COOL' and start blinking. The resistance will return to level 1 as the time counts down from 1:00.

### **ENGLISH to METRIC conversion:**

The computer display can show both ENGLISH and METRIC information. If you want to change from ENGLISH to METRIC or METRIC to ENGLISH, please follow the procedure below:

1. When the computer is in the power on status, press and holds the STOP button as 5 seconds. The PROFILE display will shows KM or ML.
2. Press the UP or DOWN buttons to switch between METRIC (KM) or ENGLISH (ML) then press the STOP button to confirm the selection and return to POWER ON status.

## WARRANTY

**Warranty Coverage:** Smooth Fitness, Inc. ("Smooth Fitness") warrants to the original purchaser that each new product to be free from defects in workmanship and material, under normal use and conditions.

**Period of Coverage:** The Warranty on this product runs from the date of your purchase for a period of LIFETIME on the frame and magnetic brake, THREE (3) years on all parts and electronics and ONE (1) year on labor. Smooth Fitness reserves the right to inspect damaged parts for misuse.

It is recommended that the Original Receipt be kept with the product manual.

**Remedy Provided by Smooth Fitness:** Smooth Fitness will provide a replacement part free of charge if a defect is found during the Warranty period. You must pay any charges for shipping and handling outside of the Continental United States and for labor. To obtain service call your local Smooth Retailer.

Any redemption may be by repair or replacement of the affected parts and/or product at the sole discretion of Smooth Fitness, by personnel approved by Smooth Fitness. If repairs are required, the unit will be repaired at the location of use or by return to the factory as deemed appropriate by Smooth Fitness.

Parts repaired or replaced pursuant to this Warranty shall be warranted for the unexpired portion of the Warranty applying to the original product. Any technical advice furnished before or after delivery in regard to the use or application of Smooth Fitness products is furnished without charge and on the basis that it represents Smooth Fitness' best judgment under the circumstances but that the advice is used at your sole risk.

**Procedure for Obtaining Your Remedy Under This Warranty:** To obtain service call your local Smooth Retailer. To help them assist you, please have the following information ready:

- Model name or number from the cover of the manual;
- Serial number located on the frame of the unit; and
- The part description and the order number.

**Limitations on Warranty:** This Warranty will only apply to the original end user. This Warranty does not cover any problems, damages or failures that are caused by accident, improper assembly, failure to observe cautionary labels on the product, failure to operate the product correctly, abuse or freight damage. Smooth Fitness does not warrant against any damage or defects that may result from repair or alterations made to the product by an unauthorized repair facility.

This Warranty shall terminate if you sell or otherwise transfer this product. This Warranty does not apply to any product shipped or handled outside of the United States or Canada. This Warranty does not apply if the product is used for rental or commercial use. Consequential and incidental damages are not recoverable under this Warranty. (Some states do not allow the exclusion or limitation of incidental or consequential damages, so the above limitation or exclusion may not apply to you.)

THIS WARRANTY IS EXPRESSLY IN LIEU OF ALL OTHER EXPRESS WARRANTIES. ALL IMPLIED WARRANTIES, INCLUDING WARRANTIES OF MERCHANTABILITY OR FITNESS FOR ANY PARTICULAR PURPOSE, ARE LIMITED IN DURATION TO ONE (1) YEAR FROM THE EFFECTIVE DATE OF THIS WARRANTY. SMOOTH FITNESS IS NOT LIABLE FOR CONSEQUENTIAL OR INCIDENTAL DAMAGES RESULTING FROM ANY DEFECT IN PARTS NOR FOR ANY BREACH OF EXPRESS OR IMPLIED WARRANTIES. SMOOTH FITNESS' SOLE LIABILITY UNDER THIS WARRANTY IS LIMITED TO THE TERMS DESCRIBED IN THIS FORM. THIS WARRANTY GIVES YOU SPECIFIC LEGAL RIGHTS, AND YOU MAY ALSO HAVE OTHER RIGHTS WHICH VARY FROM STATE TO STATE.

For assistance with assembly or to order replacement parts, simply call your local Smooth Retailer. To help them assist you, please have the following information ready:

- Model name or number from the cover of the manual;
- Serial number located on the frame of the unit; and
- The part description and order number.

## IMPORTANT STEPS

### **Warning:**

Before using this product, please consult your personal physician for a complete physical examination. Frequent and strenuous exercise should be approved by your doctor first. If any discomfort should result from your use of this product, stop exercising and consult your doctor. Proper usage of this product is essential. Please read your manual carefully before exercising.

Please keep all children away from the equipment during use and when equipment is unattended.

Always wear appropriate clothing, including athletic shoes, when exercising. Do not wear loose clothing that could become caught during exercising.

Make sure that all bolts and nuts are tightened when equipment is in use. Periodic maintenance is required on all exercise equipment to keep it in good condition.

### **Before beginning:**

How you begin your exercise program depends on your physical condition. If you have been inactive for several years, or are severely overweight, you must start slowly and increase your time gradually, a few minutes per week.

Initially you may be able to exercise only for a few minutes in your target zone. However, your aerobic fitness will improve over the next six to eight weeks. Don't be discouraged if it takes longer. It's important to work at your own pace. Ultimately, you'll be able to exercise continuously for 30 minutes. And the better your aerobic fitness, the harder you will have to work to stay in your target zone. But remember these essentials:

- Contact your physician before starting a workout or training program. Have your doctor review your training and diet programs to advise you of a workout routine you should adopt.
- Begin your training program slowly with realistic goals that have been set by you and your doctor.
- Supplement your program with some type of aerobic exercise such as walking, jogging, swimming, dancing and/or bicycling. Monitor your pulse frequently. If you do not have an electronic heart rate monitor, have your physician show you the proper way to manually check your pulse by using your wrist or neck. Establish your target heart rate based on your age and condition.
- Drink plenty of fluids during the course of your routine. You must replace the water content lost from excessive exercising to avoid dehydration. Avoid drinking large amounts of cold liquids. Fluids should be at room temperature when consumed.



The Surgeon General  
has determined that lack  
of physical activity is  
detrimental to your health.™

## TARGET HEART RATE

### Finding your pulse:

To make sure your heart is beating in its target zone, you'll need to know how to monitor your heart rate. The easiest way is to feel the pulse in the carotid artery on either side of your neck, between the windpipe and the large neck muscles. Count the number of beats in ten seconds, and then multiply that number by six. This gives you the number of beats per minute.

How fast should your heart beat during aerobic exercise? Fast enough to reach and stay in its "target zone," a range of beats per minute that is largely determined by your age and physical condition. To determine your target zone, consult the chart we have provided.

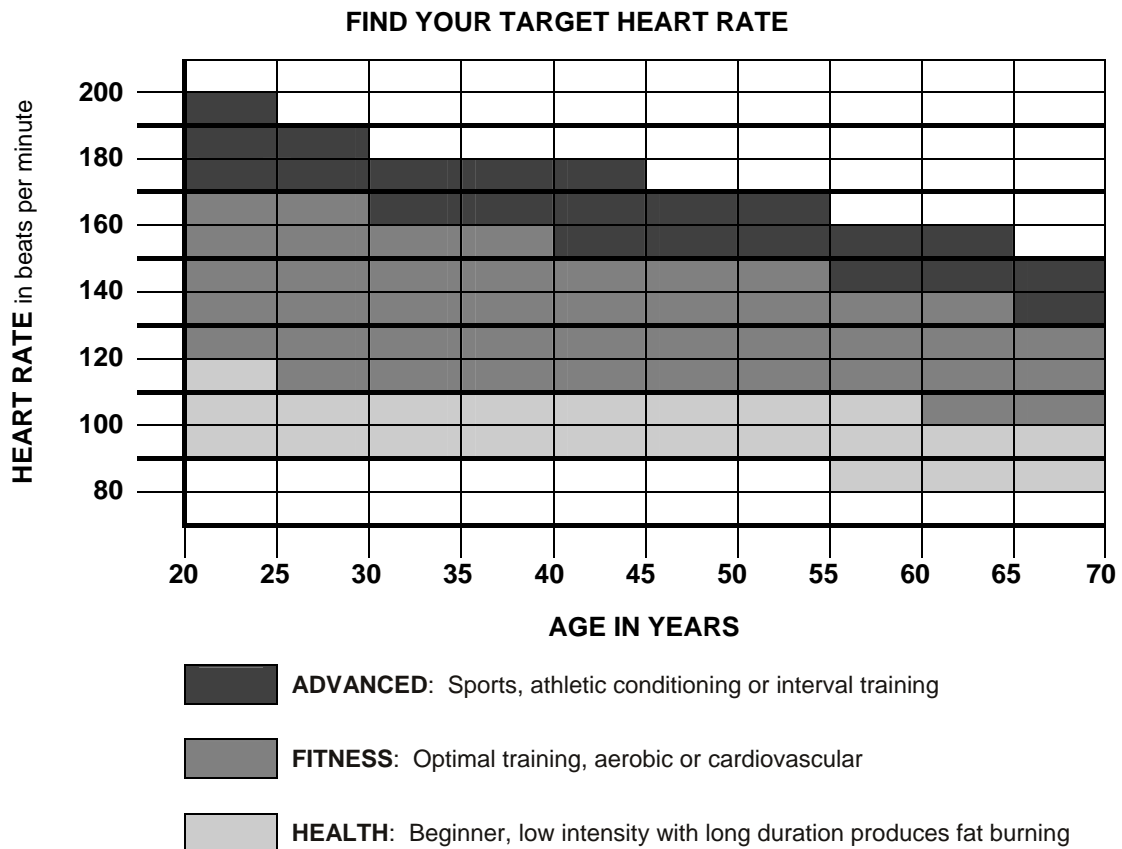

### Aerobic exercise:

Is any sustained activity that sends oxygen to your muscles via your heart and lungs. It will improve the fitness of your lungs and heart: your body's most important muscle. Aerobic fitness is promoted by any activity that uses your large muscle groups - arms, legs or buttocks, for example. Your heart beats quickly and you breathe deeply. An aerobic exercise should be part of your entire exercise routine.



MUSCLE CHART**Targeted muscle groups:**

The exercise routine that is performed on this product will develop the upper and lower body muscle groups. These muscle groups are shown in gray color on the chart below.

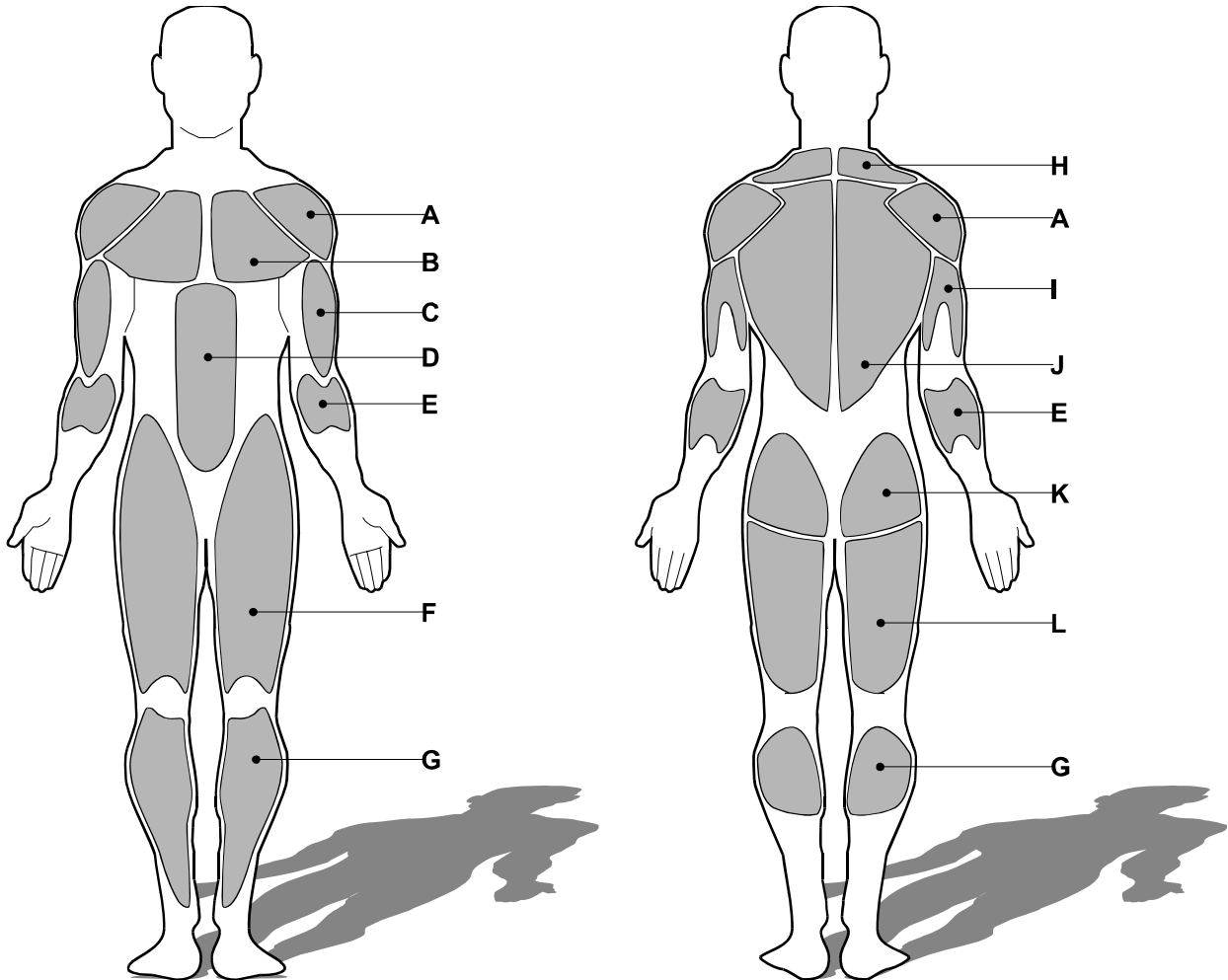

Shoulder muscles	<input type="text" value="A"/>	<input type="text" value="B"/>	Pectoral muscles
Bicep muscle	<input type="text" value="C"/>	<input type="text" value="D"/>	Abdominal muscles
Forearm muscles	<input type="text" value="E"/>	<input type="text" value="F"/>	Quadricep muscles
Calf muscles	<input type="text" value="G"/>	<input type="text" value="H"/>	Trapezius muscles
Tricep muscles	<input type="text" value="I"/>	<input type="text" value="J"/>	Back muscles
Gluteal muscles	<input type="text" value="K"/>	<input type="text" value="L"/>	Hamstring muscles

## STRETCHING ROUTINE

### **Warm up and cool down:**

A successful exercise program consists of a warm-up, aerobic exercise, and a cool-down. Do the entire program at least two and preferably three times a week, resting for a day between workouts. After several months, you can increase your workouts to four or five times per week.

Warming up is an important part of your workout, and should begin every session. It prepares your body for more strenuous exercise by heating up and stretching out your muscles, increasing your circulation and pulse rate, and delivering more oxygen to your muscles. At the end of your workout, repeat these exercises to reduce sore muscle problems. We suggest the warm-up and cool-down exercises on the following pages:

### **Toe Touch:**

Slowly bend forward from your waist, letting your back and shoulders relax as you stretch toward your toes. Reach down as far as you can and hold for 15 counts.

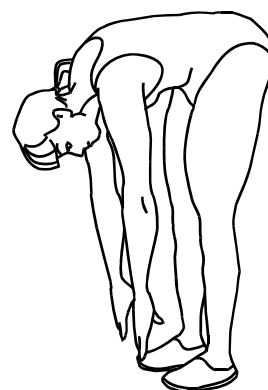

### **Shoulder Lift:**

Lift your right shoulder up toward your ear for one count. Then lift your left shoulder up for one count as you lower your right shoulder.



### **Head Roll:**

Rotate your head to the right for one count, feeling the stretch up the left side of your neck. Next, rotate your head back for one count, stretching your chin to the ceiling and letting your mouth open. Rotate your head to the left for one count, and finally, drop your head to your chest for one count.



STRETCHING ROUTINE**Hamstring Stretch:**

Sit with your right leg extended. Rest the sole of your left foot against your right inner thigh. Stretch toward your toe as far as possible. Hold for 15 counts. Relax and then repeat with left leg extended.

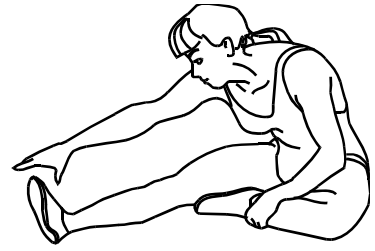
**Inner Thigh Stretch:**

Sit with the soles of your feet together with your knees pointing outward. Pull your feet as close into your groin as possible. Gently push your knees towards the floor. Hold for 15 counts.

**Side Stretch:**

Open your arms to the side and continue lifting them until they are over your head. Reach your right arm as far upward toward the ceiling as you can for one count. Feel the stretch up your right side. Repeat this action with your left arm.

**Calf-Achilles Stretch:**

Lean against a wall with your left leg in front of the right and your arms forward. Keep your right leg straight and the left foot on the floor; then bend the left leg and lean forward by moving your hips toward the wall. Hold, and then repeat on the other side for 15 counts.

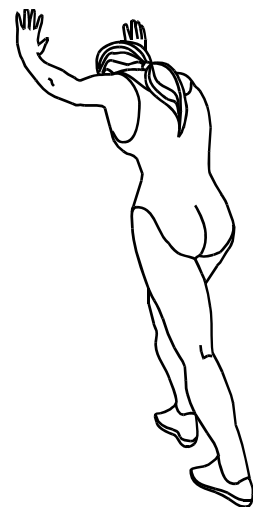



Smooth Fitness  
112 Gaither Drive  
Mt. Laurel, NJ 08054

Toll Free Customer Service:  
**1.888.800.1167**

Website:  
**www.evofitness.com**

## Free Manuals Download Website

<http://myh66.com>

<http://usermanuals.us>

<http://www.somanuals.com>

<http://www.4manuals.cc>

<http://www.manual-lib.com>

<http://www.404manual.com>

<http://www.luxmanual.com>

<http://aubethermostatmanual.com>

Golf course search by state

<http://golfingnear.com>

Email search by domain

<http://emailbydomain.com>

Auto manuals search

<http://auto.somanuals.com>

TV manuals search

<http://tv.somanuals.com>