



INDUSTRIAL POWER

A Division of **EXIDE** Technologies

DEC200 SERIES INDUSTRIAL BATTERY CHARGER I&O MANUAL



TABLE OF CONTENTS

| TITLE | Page |
|--|--------------|
| 1. Important Operating Instructions | 2 |
| 2. Introduction | 3 |
| 3. Receiving Instructions | 3 |
| 4. Location and Installation of Charger | 3 |
| 5. Stacking | 3-4 |
| 6. AC Electrical Supply | 5-8 |
| 6.1 Branch Circuit Protection | 5 |
| 6.2 AC Voltage Connections | 8 |
| 6.3 Ground Connection | 8 |
| 7. DC Output | 8 |
| 8. Fault and Display Codes | 8 |
| 9. DEC200 Standard Charger Operation | 9 |
| 10. Charger Functional Description | 10 |
| 10.1 LED Descriptions | 10 |
| 10.2 Pause Push Button | 10 |
| 10.3 Smart Start Stage | 10 |
| 10.4 Auto Balance | 10 |
| 10.5 Equalize Stage | 10 |
| 10.6 Equalize Pushbutton | 11 |
| 10.7 Low Battery Override/Recovery | 11 |
| 10.8 Incorrect Battery Limits | 11 |
| 10.9 AC Power Failure | 11 |
| 11. Maintenance | 12 |
| Appendix A Fault Codes | 13 |
| Appendix B DEC200 Troubleshooting | 14 |
| Appendix C Technical Data | 15 |
| Appendix D Circuit Diagrams | 16-17 |
| Appendix E Cabinet Dimensions | 18 |

DEC200 SERIES INDUSTRIAL BATTERY CHARGERS

1. IMPORTANT OPERATING AND SAFETY INSTRUCTIONS

SAVE THESE INSTRUCTIONS

- a) Before using the battery charger, read all the instructions in addition to the CAUTION, WARNING, and DANGER markings on the charger, battery, and all the associated equipment.
- b) Do not touch un-insulated parts of the DC output connector or the battery terminals, as there is a possibility of electric shock.
- c) Connect or disconnect the battery plug only when the charger output is off. **ALWAYS press the PAUSE pushbutton before unplugging the battery to prevent arcing or burning.**
- d) If the battery is unplugged during charging, the charger will indicate "F18". To restart the charger, plug in the next battery. Do not connect the next battery before you see indication "- - -" or "F18".
- e) Only qualified personnel should operate or service this equipment.
- f) De-energize all AC and DC power connections before servicing this unit. If injury does occur, apply the prescribed treatment for electrical shock and obtain medical attention immediately.
- g) The charger is NOT for outdoor use. Do not expose the charger to rain or snow.
- h) This charger is factory set to charge lead-acid batteries only. The operating environment should not contain any materials that may cause corrosion or contamination that would degrade the performance of a charger.
- i) Do not operate this unit if it has received a sharp blow, been dropped or otherwise damaged. Take it to a qualified GNB Industrial Power Motive Power service center.
- j) Do not disassemble the charger. Have the charger examined by an GNB Industrial Power Motive Power service representative or local qualified service facility. Incorrect re-assembly of the charger may result in an explosion, electric shock or fire.
- k) The charger profile is set at the factory for a charger DC cable length of 9 ft and a battery DC cable length of 25 in. If DC cable lengths are adjusted, please contact your local GNB Industrial Power Motive Power service representative.

2. INTRODUCTION

The GNB® DEC200 battery chargers are fan cooled, solid state, microprocessor controlled, SCR regulated chargers designed to make battery charging simple. They are designed to charge flooded lead-acid batteries. The charger has a comprehensive self-checking diagnostic program to control all charger functions, monitor the quality of charge and check its own safety conditions.

3. RECEIVING CHARGER

Examine the charger thoroughly before using, to make sure that no parts have been loosened or damaged during shipment. Check the contents of the package against the delivery slip before disposing of the shipping package. If any shipping damage or partial loss is found, file a claim with the carrier without delay and take any necessary steps to protect your rights. Before installing, check that the charger nameplate data corresponds to the packing slip and to the model specified on the original sales order. The DEC200 chargers are delivered on skids for easy handling using a forklift truck.

4. LOCATION AND INSTALLATION OF CHARGER

Proper installation is important in order to achieve good charger performance and long trouble free operation and to prevent damage to the charger and batteries. The charger should be located in a clean, cool, normal ambient room temperature (between +32°F/0°C and 104°F/40°C), dry and well-ventilated area. In order to permit free air flow for convection cooling allow four inches minimum between the charger and any wall, six inches from other equipment, and never store anything beneath or on top of the charger.

5. STACKING

The following recommendations should be taken into consideration when stacking these units:

- a) The base unit should be secured to the floor or a solid base using appropriate bolts and with accordance to local building codes and regulations.
- b) These units can be stacked to a maximum 3 high.
- c) If a lifting sling is used, the sling should be placed under the unit where the base plate is located to avoid damage to the units.

Lifting Sequence is as follows: -

- a) Secure the base unit to the floor or solid base. The bolts can be accessed and secured from the underside of the unit at the front and rear or from inside the unit where the large holes are located directly above mounting holes (see appendix G for mounting hole locations). When accessing the mounting holes from the inside, it is recommended you use a long handle hexagon key or screwdriver with the hexagon key inserted. This will allow you to go through the base plate to the bolts, which are located on the flange.

- b) Remove the bolts from the top cover of the base unit, but do not discard these, as they will be required to fix the two units together.
- c) Use an appropriate lifting sling to lift the second unit on to the base unit, inch the second unit over the base unit and align the holes before resting the second unit on top.
- d) Secure the two units together using the bolts removed from the top cover of the base unit. Use the access between the two units or inside the second unit using the tools as recommended above.
- e) If stacking three high, use the above procedure for stacking the third unit.

WARNING: THESE PROCEDURES MUST BE FOLLOWED EXACTLY TO AVOID INJURY OR RISK OF ELECTRIC SHOCK.

WARNING: TO REDUCE THE RISK OF FIRE, INSTALL BATTERY CHARGER ON A FLOOR OF NON-COMBUSTIBLE MATERIAL SUCH AS STONE, BRICK, CONCRETE OR METAL. IF THIS IS NOT AVAILABLE, A FLOOR PLATE OF AT LEAST 1.43mm GALVANIZED OR 1.6mm UNCOATED STEEL EXTENDED AT LEAST 150mm BEYOND THE EQUIPMENT ON ALL SIDES MUST BE INSTALLED.

6. AC ELECTRICAL SUPPLY

The charger must be connected to either a single phase or three phase, 60 Hertz ($\pm 2\%$) AC power source. Three phase chargers cannot be powered with a single phase source.

The following transformer options are available:

TABLE 1 – INPUT VOLTAGE CHOICES

| Single phase | Three phase |
|----------------------|----------------------|
| 208/240/480VAC, 60Hz | 208/240/480VAC, 60Hz |

Only the AC input wire configuration for multi-input chargers can be changed. Follow Figure 1 (page 6) for single-phase input or Figure 2 (page 7) for three-phase input transformers. A qualified electrical contractor should perform this adjustment.

6.1. BRANCH CIRCUIT PROTECTION

The charger comes with an internal supplementary protective device rated to accommodate the highest possible current and voltage for that model.

CAUTION: TO REDUCE THE RISK OF FIRE, USE ONLY ON CIRCUITS PROVIDED WITH BRANCH CIRCUIT PROTECTION CONSISTENT WITH THE CURRENT INDICATED ON THE FRONT PANEL-RATING LABEL AND IN ACCORDANCE WITH THE NATIONAL ELECTRICAL CODE, ANSI/NFPA 70.

FIGURE 1: SINGLE PHASE INPUT

WARNING: IMPROPER WIRE AND JUMPER CONNECTION MAY CAUSE SEVERE DAMAGE TO THE CHARGER AND BATTERY

NOTE: Live connection 'L' Must be connected to the breaker. The mains input are the only user configurable connections. PCB connections must NOT be altered from factory setting.

208 VAC 60Hz CONFIGURATION (208/240/480V INPUT)

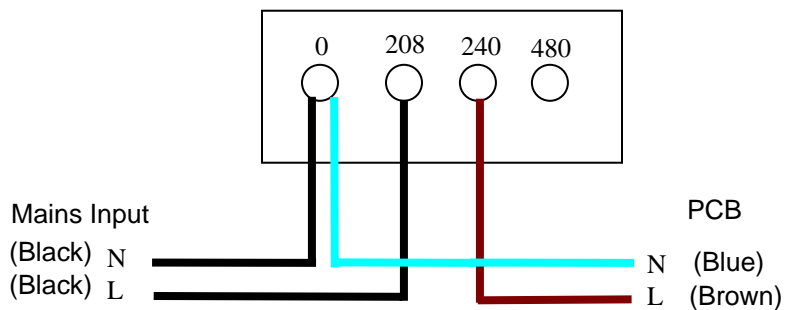

240 VAC 60Hz CONFIGURATION (208/240/480V INPUT)

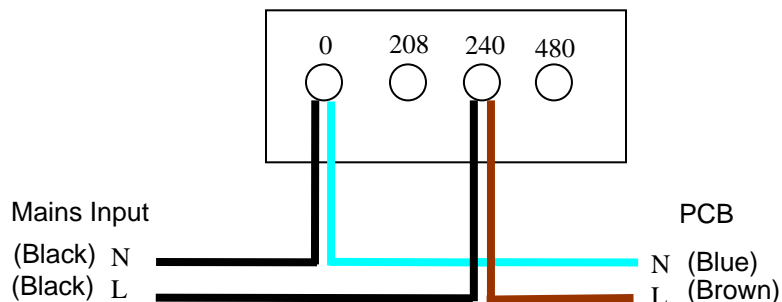

480 VAC 60Hz CONFIGURATION (208/240/480V INPUT)

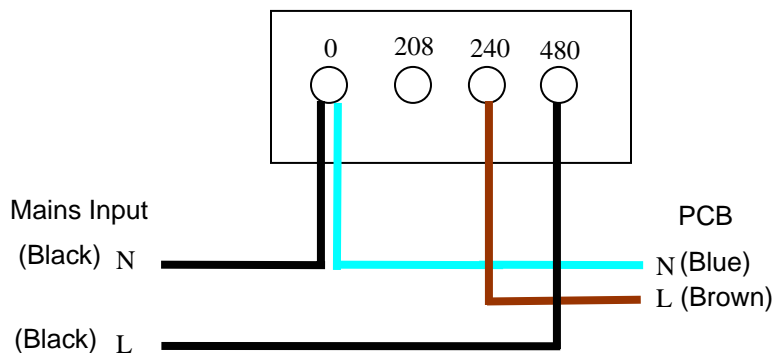
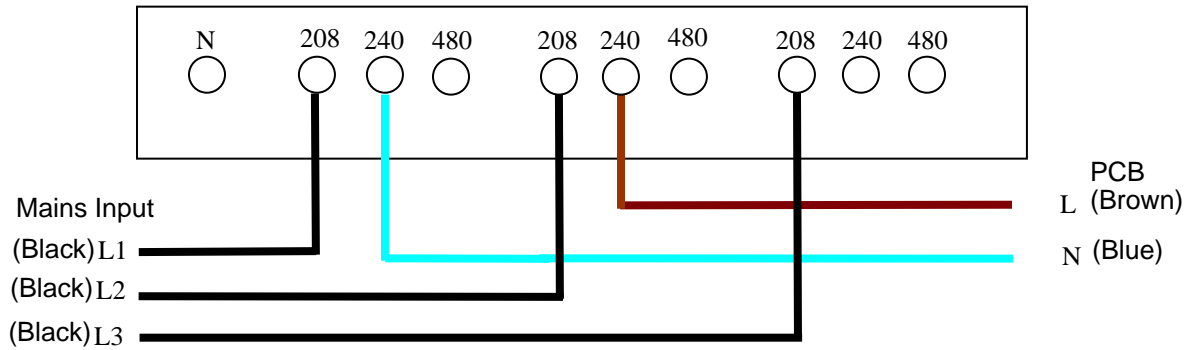

FIGURE 2: THREE-PHASE INPUT

WARNING: IMPROPER WIRE AND JUMPER CONNECTION MAY CAUSE SEVERE DAMAGE TO THE CHARGER AND BATTERY

NOTE: PCB connections must NOT be altered from factory setting.

208VAC 60 Hz CONFIGURATION (208/240/480V INPUT)



240VAC 60 Hz CONFIGURATION (208/240/480V INPUT)

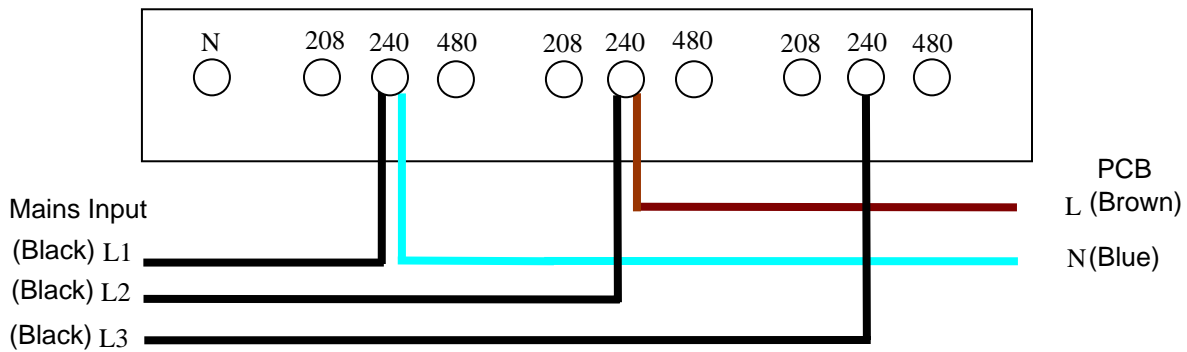

480VAC 60 Hz CONFIGURATION (208/240/480V INPUT)

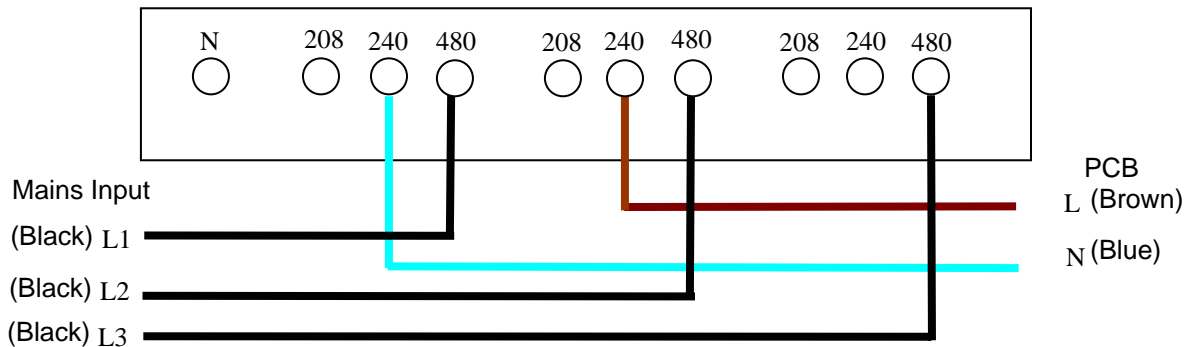

6.2. AC VOLTAGE CONNECTIONS

To connect the input AC voltage, route the AC conduit through the knockout hole provided. Continue the AC wiring to the breaker terminals L1 (N) and L2 (L) (single phase input) or L1, L2, and L3 (three phase input). For proper connection, torque the screws to approximately 25 inch-pounds.

6.3. GROUND CONNECTION

It is a requirement to ground the chassis while the charger is connected to AC power. The charger comes with a threaded M6 hole, clearly marked on the chassis. To ensure good continuity, keep the contact area clean.

WARNING: DO NOT OPERATE THE UNIT WITHOUT PROPER GROUNDING. IMPROPER GROUNDING CAN RESULT IN THE RISK OF AN ELECTRIC SHOCK.

CAUTION: USE MINIMUM 75°C WIRING FOR SUPPLY CONNECTIONS. GROUND THE CHARGER PROPERLY USING THE THREADED M6 HOLE (GND) PROVIDED. USE COPPER-CLAD ALUMINUM, ALUMINUM OR COPPER CONDUCTORS ONLY.

After electrical connection is completed, the charger is ready for operation.

7. DC OUTPUT

The DC charging cable has a commonly used battery plug or receptacle. The polarity of the charger plug must be the same as the battery connector. The BLACK DC cable must be connected to the battery negative terminal (-) and the RED DC cable must be connected to the battery positive terminal (+). The charger will not operate in a reversed polarity condition. The DC output fuse is a "fast-acting" fuse used to protect the power semiconductors of a charger.

NOTE: Use only identical replacement fuses available from your GNB Industrial Power Motive Power service representative. The DC fuse must be replaced with a fast acting fuse capable of protecting semiconductors. See Appendix C and D for correct fuse sizes.

8. FAULT AND DISPLAY CODES

Refer to **Appendix A and B** (on pages 13 and 14) for a complete list of fault codes.

9. DEC200 STANDARD CHARGER OPERATION

| CHARGE CONDITION | DISPLAY DEFAULT | FUNCTION BUTTON DISPLAY SELECTION | LED |
|--------------------------|--------------------------|------------------------------------|--------------|
| CHARGING | <i>A</i> | <i>A, Ph</i> | <i>Y</i> |
| TERMINATION | <i>rEdy</i> | | <i>G</i> |
| TERMINATION/ FAULT CODE | <i>rEdy / F</i> | | <i>R*, G</i> |
| SETTING EQUALISE | <i>EqAL</i> | for 5 seconds then default display | Charge stage |
| EQUALISE CHARGE | <i>A / EqAL</i> | | <i>G*, Y</i> |
| AUTO BALANCE | <i>StSt / A StSt / V</i> | | <i>G</i> |
| LoBt CHARGE PERIOD | <i>LoBt / A</i> | | <i>Y*</i> |
| LoBt OFF PERIOD | <i>LoBt / V</i> | | |
| CRITICAL FAULT CODE | <i>F</i> | | <i>R</i> |
| NONE CRITICAL FAULT CODE | <i>F</i> | Charge continues | <i>R*</i> |

A = Output current
F = Fault code, display will alternate with the two codes
Ph = Phase of charge i.e. 1, 2 and 3
StSt = Smart start
LoBt = low battery override
/ = Display will alternate with the two-displayed information

*= flashing LED.

NOTE: In LoBt, StSt, Equalize and Termination charge function display will only be displayed for 10 seconds, not permanently.

Display if due to smart start.

R: Red = Fault, flashing red is a none critical fault.
Y: Yellow = Current flowing, flashing yellow when < 2.37VPC.
G: Green = charge complete.

10. CHARGER FUNCTIONAL DESCRIPTION

10.1. LED Descriptions

| LED | Description |
|-----------------|-------------------------------|
| Yellow Flashing | High Rate Current |
| Yellow Solid | 80% Charged |
| Green Solid | Charge Complete |
| Red | Fault – See page 15 for codes |

10.2. PAUSE PUSH BUTTON

This **PAUSE** push button will halt the charge cycle. The battery can then be safely unplugged for up to 10 minutes. If the battery is still connected after this time, the charger will continue with the present charge cycle.

10.3 SMART START

If the time to gassing voltage, (2.40 VPC), is less than 30 minutes, the normal charge profile will terminate and the unit will charge at constant voltage (2.35VPC) until 22% of the maximum current is reached. The charger will then proceed to the auto-balance stage.

10.4 AUTO BALANCE

The charger maintains a constant current level of 22% of maximum output that is activated by voltage, on at 2.20VPC and off at 2.40VPC with a time limit of 1 hour if 2.40VPC is not reached.

When current is flowing, amps will be displayed and the yellow LED will be illuminated. When no current is flowing, the display will show 'StSt'. The **FUNCTION** button can select charge information. The green LED will remain illuminated.

10.5 EQUALIZE STAGE

Equalize charge consists of 12 hours at 22% of maximum output.

The following table summarizes the action taken when Equalize is set manually during different charge modes...

| Charge Mode | Action |
|--------------------------|-----------------------------------|
| During recharge | Equalize active after termination |
| After charge termination | Equalize active immediately |
| Smart Start termination | Equalize active after termination |

10.6 EQUALIZE PUSHBUTTON

Equalize charge can be enabled/disabled, when the **FUNCTION** button is depressed > 5 second at anytime whilst a battery is connected. Only one equalize charge per recharge cycle is permitted.

CAUTION: DO NOT EQUALIZE MORE OFTEN THAN REQUIRED BY THE CONDITION OF THE BATTERY, AS SPECIFIED IN THE BATTERY MAINTENANCE INSTRUCTIONS. EXCESSIVE EQUALIZING MAY DAMAGE THE BATTERY.

10.7 LOW BATTERY OVERRIDE/RECOVERY

10.7.1 CONFIGURATION

There is the ability to manually override the low 'Incorrect Battery' threshold of 1.70 VPC, down to a minimum of 1.00 VPC - the level at which the charger will recognize a battery connection. This is achieved by holding the **FUNCTION** push button for 5 seconds when the incorrect battery fault has been detected.

10.7.2 OPERATION

If 'Low Battery Override' has been enabled and a battery (voltage > 1.00 VPC) is connected to the charger, the charger will pass current at 75% of the maximum output current.

If less than 3.0VPC, current will flow for 5 minutes and the charge will be suspended for 5 minutes. The cycle is repeated until the battery voltage is greater than 1.70 VPC at the end of the 5-minute rest period.

If the battery voltage is greater than 1.70 VPC at the end of the 5-minute rest period, the battery recovery mode will cease and charge will start from stage 1 with smart start disabled.

If 3.0 VPC is reached within the 5 minutes of charge, the charge will be suspended equal to the 'on' time, maximum of 5 minutes. During this period the display will show 'Lobt'. During the 5-minute off period the display will show the battery volts per cell alternating with 'Lobt'.

10.8 INCORRECT BATTERY LIMITS

Incorrect battery detection limits will be < 1.70 VPC and > 2.25 VPC (off charge). If the battery voltage comes within this window the charger will automatically commence charging.

10.9 AC POWER FAILURE

If the AC power fails during a charge cycle, the charger will resume the cycle at the point of termination as soon as AC power is restored.

11 MAINTENANCE

The charger requires minimum maintenance. ENSURE THE CHASSIS IS SECURELY GROUNDED per the local/federal Electrical Code. Do not allow excessive dust to accumulate on the components inside. Blow out with clean compressed air when necessary. The chargers are designed with a breaker and fuse for the AC input and DC output respectively. Should this fuse fail or breaker trip, the cause must be determined before they are corrected or replaced. Never replace the fuse or breaker with one of a higher capacity than the one originally fitted.

APPENDIX A – FAULT CODES

| CODE | STATUS | DESCRIPTION |
|-----------------|----------|---|
| F01 | N | Over discharged battery (<1.90vpc after 30 seconds of charge) |
| F02 | N | Deep discharged battery (<1.90vpc after 30 seconds of charge > 1.90vpc) |
| F03 | N | Sulphated battery |
| F04 | S | Charger over heating |
| F05 | S | Mains failed during charge |
| F06 | R | No output current |
| F07 | C | Incorrect battery < 1.70 |
| F07 (+Y led on) | C | Incorrect battery > 2.25 |
| F09 | C | Bulk charge time-out |
| F10 | C | Second stage time-out (Profile Dependant) |
| F11 | C | Incorrect Mains Frequency |
| F12 | C | Control hardware (MCU) |
| F13 | S | Thermistor fault |
| F16 | S | Battery overheating (if temp probe fitted) |
| F17 | C | Auto balance charge time-out |
| F18 | C | Battery disconnected without pausing charge |
| F22 | C | di/dt termination |

Key: -

C = critical fault ⇒ charge stopped ⇒ fault code displayed permanently

S = suspend fault ⇒ charge suspended until criteria fulfilled ⇒ fault code displayed permanently

R = retry fault ⇒ charge retries after 20 seconds ⇒ fault code display alternating with standard display

N = non-critical fault ⇒ charge continues ⇒ fault code display alternating with standard display

APPENDIX B – DEC200 TROUBLESHOOTING

| SYMPTOM | POSSIBLE CAUSE | EXPLANATION / ACTION |
|------------|-----------------------------|---|
| No Display | No AC Power | Check Input Power. Check Breaker. Mains fuse on Control Board |
| F01 | Deeply Discharged Battery | Battery Voltage less than 1.9 volts per cell initially but rose above this level within the first minute. Check battery condition and Equalize. |
| F02 | Over discharge | Battery less than 1.9 volts per cell after the first minute of charge. Check battery condition and Equalize |
| F03 | Sulphated Battery | Make sure your battery gets a full charge every cycle. Check battery condition and Equalize. |
| F04 | Charger Overheating | Check Fan for operation on initial power up. Ensure adequate ventilation. Contact your local GNB Industrial Power Motive Power representative. |
| F05 | Mains Failure | Electrical Supply failure during charge. (Power Cut) |
| F06 | No Output Current | Check DC Fuse, SCRs. Connection to Battery. |
| F07 | Incorrect Battery | Make sure the battery voltage matches the charger voltage. |
| | Low Voltage | Check battery voltage with a voltage meter. Make sure battery voltage matches charger. Battery may require servicing. |
| | High Voltage | Check battery voltage with a voltage meter. Make sure battery voltage matches charger. |
| F09 | Battery Failure | Battery did not reach gassing volts within the time limit. Check battery for low voltage. Confirm charger capacity is correctly matched to battery. Check battery condition. Contact your local GNB Industrial Power Motive Power representative. |
| F10 | Second Stage Time-Out | I2 limit not reached within time limit. Check battery condition. Contact your local GNB Industrial Power Motive Power representative. |
| F11 | Incorrect Mains Frequency | Check the mains supply. |
| F12 | Board Failure | Contact your local GNB Industrial Power Motive Power representative. |
| F13 | Temperature Sensor Failure | Contact your local GNB Industrial Power Motive Power representative. |
| F17 | Auto Balance Stage Time Out | Check battery condition. |
| F16 | Battery Overheating | Check battery for High Temperature. Allow battery to cool. Check battery condition. Confirm charger capacity is correctly matched to battery |
| F18 | Battery Disconnection | Press the PAUSE button before disconnecting the battery. |
| F22 | Overheated Battery | Check battery condition. |

APPENDIX C –TECHNICAL DATA

| Model Numbers | Amp-Hour Rating | | | DC Volt | DC Amps | AC AMPS (RMS) @ AC VOLTS @ 2.4 VPC | | | SHIPPING DATA | | |
|---------------------|-----------------|---------|---------|---------|---------|------------------------------------|---------|---------|---------------|--------|-----|
| | 10 Hour | 12 Hour | 14 Hour | | | 208 Vac | 240 Vac | 480 Vac | Cabinet Size | WEIGHT | |
| | | | | | | | | | | Lbs | KG |
| Single Phase | | | | | | | | | | | |
| DEC200-24V-40AS1H | 330 | 400 | 470 | 24 | 40 | 11.4 | 9.8 | 4.9 | M4 | 94.8 | 43 |
| DEC200-24V-75AS1H | 625 | 750 | 880 | 24 | 75 | 21.3 | 18.4 | 9.2 | M4 | 134 | 61 |
| DEC200-24V-95AS1H | 790 | 950 | 1120 | 24 | 95 | 27 | 23.4 | 11.7 | M4 | 145 | 66 |
| DEC200-24V-115AS1H | 955 | 1150 | 1350 | 24 | 115 | 32.6 | 28.3 | 14.1 | M4 | 163 | 74 |
| DEC200-24V-135AS1H | 1125 | 1350 | 1590 | 24 | 135 | 38.3 | 33.2 | 16.6 | M4 | 169 | 77 |
| DEC200-36V-75AS1H | 625 | 750 | 880 | 36 | 75 | 29.9 | 25.9 | 13 | M4 | 158 | 72 |
| DEC200-36V-95AS1H | 790 | 950 | 1120 | 36 | 95 | 37.9 | 32.9 | 16.4 | M4 | 163 | 74 |
| DEC200-36V-115AS1H | 955 | 1150 | 1350 | 36 | 115 | 45.9 | 39.8 | 19.9 | M5 | 216 | 98 |
| DEC200-36V-135AS1H | 1125 | 1350 | 1590 | 36 | 135 | 53.9 | 46.7 | 23.3 | M5 | 238 | 108 |
| Three Phase | | | | | | | | | | | |
| DEC200-24V-75AT1H | 625 | 750 | 880 | 24 | 75 | 12 | 11 | 5.3 | M4 | 134 | 61 |
| DEC200-24V-95AT1H | 790 | 950 | 1120 | 24 | 95 | 15 | 13 | 6.7 | M4 | 145 | 66 |
| DEC200-24V-115AT1H | 955 | 1150 | 1350 | 24 | 115 | 19 | 16 | 8.1 | M4 | 145 | 66 |
| DEC200-24V-135AT1H | 1125 | 1350 | 1590 | 24 | 135 | 22 | 19 | 9.5 | M4 | 180 | 82 |
| DEC200-36V-75AT1H | 625 | 750 | 880 | 36 | 75 | 18 | 16 | 7.9 | M4 | 180 | 82 |
| DEC200-36V-95AT1H | 790 | 950 | 1120 | 36 | 95 | 23 | 20 | 10 | M4 | 180 | 82 |
| DEC200-36V-115AT1H | 955 | 1150 | 1350 | 36 | 115 | 28 | 24 | 12 | M4 | 209 | 95 |
| DEC200-36V-135AT1H | 1125 | 1350 | 1590 | 36 | 135 | 33 | 28 | 14 | M5 | 275 | 125 |
| DEC200-36V-150AT1H | 1250 | 1500 | | 36 | 150 | 36.4 | 32 | 16 | M5 | 297 | 135 |
| DEC200-48V-95AT1H | 790 | 950 | 1120 | 48 | 95 | 30.7 | 27 | 13 | M5 | 264 | 120 |
| DEC200-48V-115AT1H | 955 | 1150 | 1350 | 48 | 115 | 37.2 | 32 | 16 | M5 | 288 | 130 |
| DEC200-48V-135AT1H | 1125 | 1350 | 1590 | 48 | 135 | 43.6 | 38 | 19 | M5 | 299 | 136 |

*DC FUSE MUST BE A FAST ACTING FUSE CAPABLE OF PROTECTING SEMICONDUCTORS.

APPENDIX D

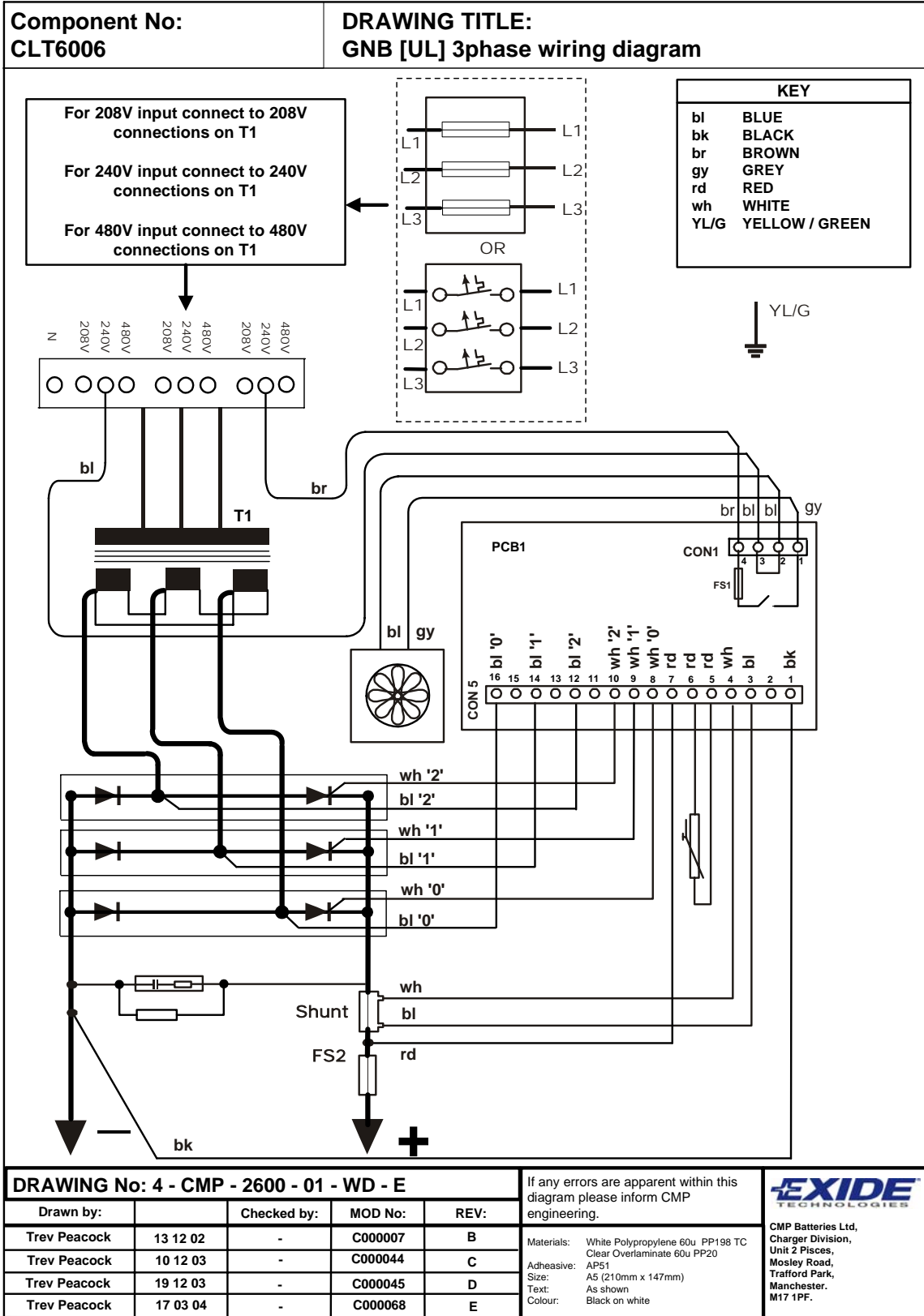

APPENDIX D

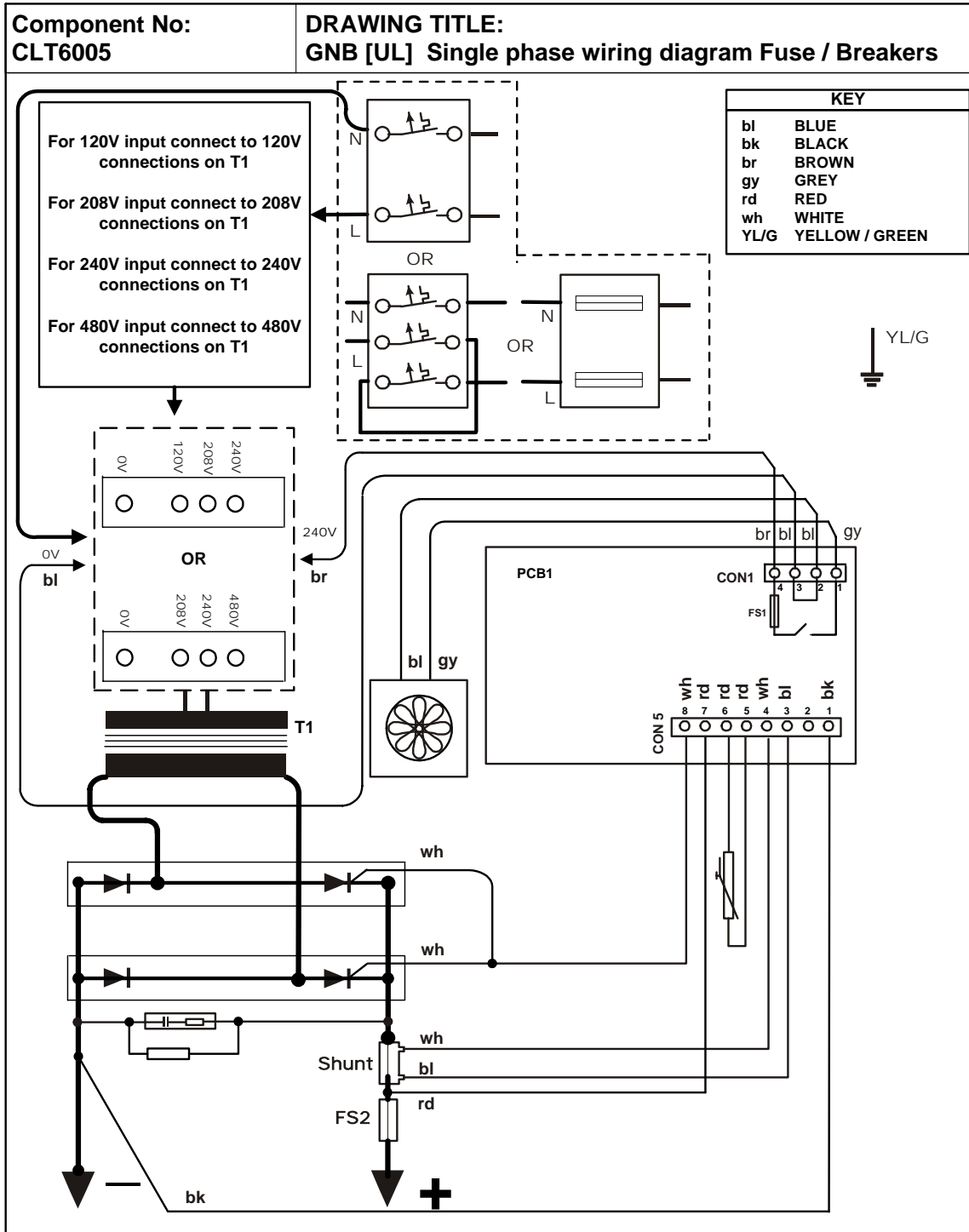

| | | | | | |
|--|-------------|---------|---------|---|--|
| DRAWING No: 4 - CMP - 2600 - 02 - WD - E | | | | | If any errors are apparent within this diagram please inform CMP engineering. EXIDE TECHNOLOGIES CMP Batteries Ltd, Charger Division, Unit 2 Pisces, Mosley Road, Trafford Park, Manchester. M17 1PF. |
| Drawn by: | Checked by: | MOD No: | REV: | | |
| Trev Peacock | 17 04 03 | - | C000007 | B | |
| Trev Peacock | 10 12 03 | - | C000044 | C | |
| Trev Peacock | 19 12 03 | - | C000045 | D | |
| Trev Peacock | 17 03 04 | - | C000068 | E | |
| Materials: White Polypropylene 60u PP198 TC Clear Overlamine 60u PP20 Adhesive: AP51 Size: A5 (210mm x 147mm) Text: As shown Colour: Black on white | | | | | |

APPENDIX E – DIMENSIONS

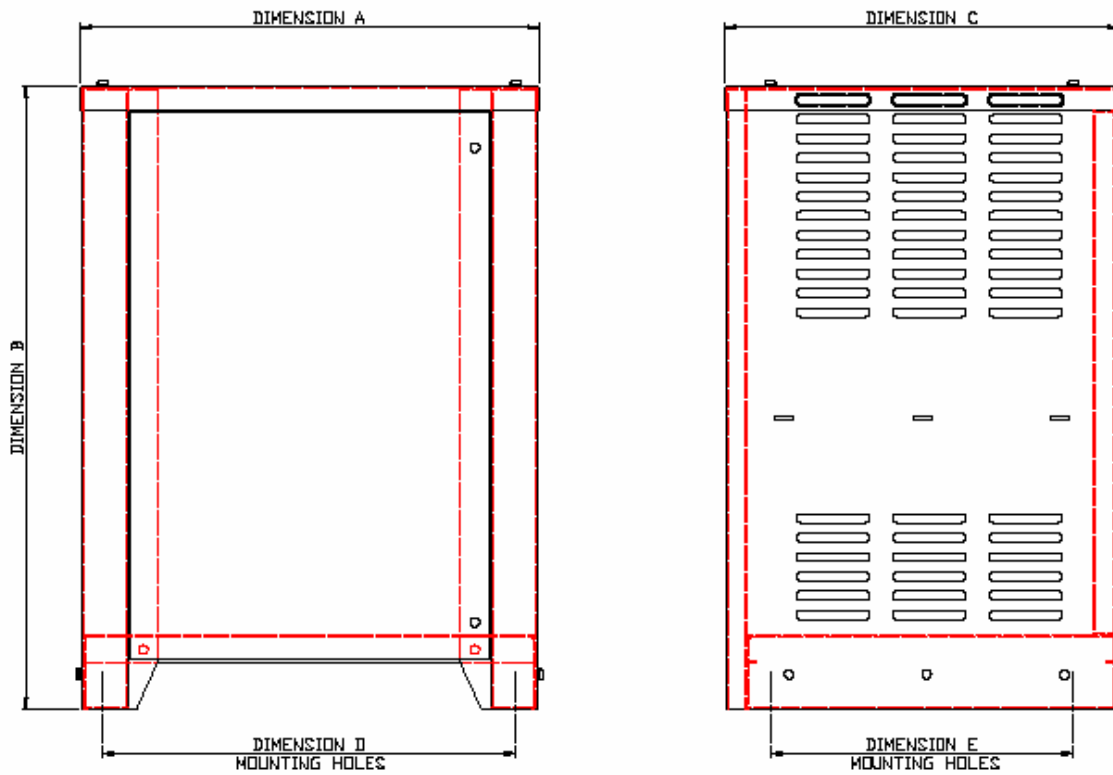

| CABINET | DIM. A | DIM. B | DIM. C | DIM. D | DIM. E |
|---------|--------|--------|--------|--------|--------|
| Size M4 | 19.69" | 26.65" | 16.93" | 17.54" | 12.99" |
| Size M5 | 23.62" | 26.65" | 20.87" | 21.48" | 16.93" |



INDUSTRIAL POWER

*A Division of **EXIDE** Technologies*

SALES – SERVICE - RECYCLING

1-888-563-6300

TOLL FREE

GNB Industrial Power
A division of Exide Technologies
U.S.A.
Tel: 877.462.4636

GNB Industrial Power
A division of Exide Technologies
Canada
Tel: 800.268.2698

V19CIL5200ULD 2004-05

www.gnb.com

Free Manuals Download Website

<http://myh66.com>

<http://usermanuals.us>

<http://www.somanuals.com>

<http://www.4manuals.cc>

<http://www.manual-lib.com>

<http://www.404manual.com>

<http://www.luxmanual.com>

<http://aubethermostatmanual.com>

Golf course search by state

<http://golfingnear.com>

Email search by domain

<http://emailbydomain.com>

Auto manuals search

<http://auto.somanuals.com>

TV manuals search

<http://tv.somanuals.com>