

XTRA™ Series

Half-Rack Audio Power Amplifiers



Extron® Electronics
INTERFACING, SWITCHING AND CONTROL

Safety Instructions • English



This symbol is intended to alert the user of important operating and maintenance (servicing) instructions in the literature provided with the equipment.



This symbol is intended to alert the user of the presence of uninsulated dangerous voltage within the product's enclosure that may present a risk of electric shock.

Caution

Read Instructions • Read and understand all safety and operating instructions before using the equipment.

Retain Instructions • The safety instructions should be kept for future reference.

Follow Warnings • Follow all warnings and instructions marked on the equipment or in the user information.

Avoid Attachments • Do not use tools or attachments that are not recommended by the equipment manufacturer because they may be hazardous.

Consignes de Sécurité • Français



Ce symbole sert à avertir l'utilisateur que la documentation fournie avec le matériel contient des instructions importantes concernant l'exploitation et la maintenance (réparation).



Ce symbole sert à avertir l'utilisateur de la présence dans le boîtier de l'appareil de tensions dangereuses non isolées posant des risques d'électrocution.

Attention

Lire les instructions • Prendre connaissance de toutes les consignes de sécurité et d'exploitation avant d'utiliser le matériel.

Conservier les instructions • Ranger les consignes de sécurité afin de pouvoir les consulter à l'avenir.

Respecter les avertissements • Observer tous les avertissements et consignes marqués sur le matériel ou présentés dans la documentation utilisateur.

Sicherheitsanleitungen • Deutsch



Dieses Symbol soll dem Benutzer in der im Lieferumfang enthaltenen Dokumentation besonders wichtige Hinweise zur Bedienung und Wartung (Instandhaltung) geben.



Dieses Symbol soll den Benutzer darauf aufmerksam machen, daß im Inneren des Gehäuses dieses Produktes gefährliche Spannungen, die nicht isoliert sind und die einen elektrischen Schock verursachen können, herrschen.

Achtung

Lesen der Anleitungen • Bevor Sie das Gerät zum ersten Mal verwenden, sollten Sie alle Sicherheits- und Bedienungsanleitungen genau durchlesen und verstehen.

Aufbewahren der Anleitungen • Die Hinweise zur elektrischen Sicherheit des Produktes sollten Sie aufbewahren, damit Sie im Bedarfsfall darauf zurückgreifen können.

Befolgen der Warnhinweise • Befolgen Sie alle Warnhinweise und Anleitungen auf dem Gerät oder in der Benutzerdokumentation.

Keine Zusatzgeräte • Verwenden Sie keine Werkzeuge oder Zusatzgeräte, die nicht ausdrücklich vom Hersteller empfohlen wurden, da diese eine Gefahrenquelle darstellen können.

Instrucciones de seguridad • Español



Este símbolo se utiliza para advertir al usuario sobre instrucciones importantes de operación y mantenimiento (o cambio de partes) que se desean destacar en el contenido de la documentación suministrada con los equipos.



Este símbolo se utiliza para advertir al usuario sobre la presencia de elementos con voltaje peligroso sin protección aislante, que puedan encontrarse dentro de la caja o alojamiento del producto, y que puedan representar riesgo de electrocución.

Precaucion

Leer las instrucciones • Leer y analizar todas las instrucciones de operación y seguridad, antes de usar el equipo.

Conservar las instrucciones • Conservar las instrucciones de seguridad para futura consulta.

Obedecer las advertencias • Todas las advertencias e instrucciones marcadas en el equipo o en la documentación del usuario, deben ser obedecidas.

安全须知 • 中文



这个符号提示用户该设备用户手册中有重要的操作和维护说明。



这个符号警告用户该设备机壳内有暴露的危险电压，有触电危险。

注意

阅读说明书 • 用户使用该设备前必须阅读并理解所有安全和使用说明。

保存说明书 • 用户应保存安全说明书以备将来使用。

遵守警告 • 用户应遵守产品和用户指南上的所有安全和操作说明。

避免追加 • 不要使用该产品的厂商没有推荐的工具或追加设备，以避免危险。

Warning

Power sources • This equipment should be operated only from the power source indicated on the product. This equipment is intended to be used with a main power system with a grounded (neutral) conductor. The third (grounding) pin is a safety feature, do not attempt to bypass or disable it.

Power disconnection • To remove power from the equipment safely, remove all power cords from the rear of the equipment, or the desktop power module (if detachable), or from the power source receptacle (wall plug).

Power cord protection • Power cords should be routed so that they are not likely to be stepped on or pinched by items placed upon or against them.

Servicing • Refer all servicing to qualified service personnel. There are no user-serviceable parts inside. To prevent the risk of shock, do not attempt to service this equipment yourself because opening or removing covers may expose you to dangerous voltage or other hazards.

Slots and openings • If the equipment has slots or holes in the enclosure, these are provided to prevent overheating of sensitive components inside. These openings must never be blocked by other objects.

Lithium battery • There is a danger of explosion if battery is incorrectly replaced. Replace it only with the same or equivalent type recommended by the manufacturer. Dispose of used batteries according to the manufacturer's instructions.

Eviter les pièces de fixation • Ne pas utiliser de pièces de fixation ni d'outils non recommandés par le fabricant du matériel car cela risquerait de poser certains dangers.

Avvertimento

Alimentazioni • Ne faire fonctionner ce matériel qu'avec la source d'alimentation indiquée sur l'appareil. Ce matériel doit être utilisé avec une alimentation principale comportant un fil de terre (neutre). Le troisième contact (de mise à la terre) constitue un dispositif de sécurité : n'essayez pas de la contourner ni de la désactiver.

Déconnexion de l'alimentation • Pour mettre le matériel hors tension sans danger, déconnectez tous les cordons d'alimentation de l'arrière de l'appareil ou du module d'alimentation de bureau (s'il est amovible) ou encore de la prise secteur.

Protection du cordon d'alimentation • Acheminer les cordons d'alimentation de manière à ce que personne ne risque de marcher dessus et à ce qu'ils ne soient pas écrasés ou pincés par des objets.

Réparation-maintenance • Faire exécuter toutes les interventions de réparation-maintenance par un technicien qualifié. Aucun des éléments internes ne peut être réparé par l'utilisateur. Afin d'éviter tout danger d'électrocution, l'utilisateur ne doit pas essayer de procéder lui-même à ces opérations car l'ouverture ou le retrait des couvercles risquent de l'exposer à de hautes tensions et autres dangers.

Fentes et orifices • Si le boîtier de l'appareil comporte des fentes ou des orifices, ceux-ci servent à empêcher les composants internes sensibles de surchauffer. Ces ouvertures ne doivent jamais être bloquées par des objets.

Lithium Batterie • Il y a danger d'explosion s'il y a un remplacement incorrect de la batterie. Remplacer uniquement avec une batterie du même type ou d'un type équivalent recommandée par le constructeur. Mettre au rebut les batteries usagées conformément aux instructions du fabricant.

Vorsicht

Stromquellen • Dieses Gerät sollte nur über die auf dem Produkt angegebene Stromquelle betrieben werden. Dieses Gerät wurde für eine Verwendung mit einer Hauptstromleitung mit einem geerdeten (neutralen) Leiter konzipiert. Der dritte Kontakt ist für einen Erdschluß, und stellt eine Sicherheitsfunktion dar. Diese sollte nicht umgangen oder außer Betrieb gesetzt werden.

Stromunterbrechung • Um das Gerät auf sichere Weise vom Netz zu trennen, sollten Sie alle Netzkabel aus der Rückseite des Gerätes, aus der externen Stromversorgung (falls dies möglich ist) oder aus der Wandsteckdose ziehen.

Schutz des Netzkabels • Netzkabel sollten stets so verlegt werden, daß sie nicht im Weg liegen und niemand darauf treten kann oder Objekte darauf- oder unmittelbar dagegengestellt werden können.

Wartung • Alle Wartungsmaßnahmen sollten nur von qualifiziertem Servicepersonal durchgeführt werden. Die internen Komponenten des Gerätes sind wartungsfrei. Zur Vermeidung eines elektrischen Schocks versuchen Sie in keinem Fall, dieses Gerät selbst öffnen, da beim Entfernen der Abdeckungen die Gefahr eines elektrischen Schlags und/oder andere Gefahren bestehen.

Schlitze und Öffnungen • Wenn das Gerät Schlitze oder Löcher im Gehäuse aufweist, dienen diese zur Vermeidung einer Überhitzung der empfindlichen Teile im Inneren. Diese Öffnungen dürfen niemals von anderen Objekten blockiert werden.

Lithium-Batterie • Explosionsgefahr, falls die Batterie nicht richtig ersetzt wird. Ersetzen Sie verbrauchte Batterien nur durch den gleichen oder einen vergleichbaren Batterietyp, der auch vom Hersteller empfohlen wird. Entsorgen Sie verbrauchte Batterien bitte gemäß den Herstelleranweisungen.

Evitar el uso de accesorios • No usar herramientas o accesorios que no sean específicamente recomendados por el fabricante, ya que podrían implicar riesgos.

Advertencia

Alimentación eléctrica • Este equipo debe conectarse únicamente a la fuente/tipo de alimentación eléctrica indicada en el mismo. La alimentación eléctrica de este equipo debe provenir de un sistema de distribución general con conductor neutro a tierra. La tercera pata (puesta a tierra) es una medida de seguridad, no puentearla ni eliminarla.

Desconexión de alimentación eléctrica • Para desconectar con seguridad la acometida de alimentación eléctrica al equipo, desenchufar todos los cables de alimentación en el panel trasero del equipo, o desenchufar el módulo de alimentación (si fuera independiente), o desenchufar el cable del receptáculo de la pared.

Protección del cables de alimentación • Los cables de alimentación eléctrica se deben instalar en lugares donde no sean pisados ni apretados por objetos que se puedan apoyar sobre ellos.

Reparaciones/mantenimiento • Solicitar siempre los servicios técnicos de personal calificado. En el interior no hay partes a las que el usuario deba acceder. Para evitar riesgos de electrocución, no intentar personalmente la reparación/mantenimiento de este equipo, ya que al abrir o extraer las tapas puede quedar expuesto a voltajes peligrosos u otros riesgos.

Ranuras y aberturas • Si el equipo posee ranuras o orificios en su caja/alojamiento, es para evitar el sobrecalentamiento de componentes internos sensibles. Estas aberturas nunca se deben obstruir con otros objetos.

Batería de litio • Existe riesgo de explosión si esta batería se coloca en la posición incorrecta. Cambiar esta batería únicamente con el mismo tipo (o su equivalente) recomendado por el fabricante. Desachar las baterías usadas siguiendo las instrucciones del fabricante.

警告

电源 • 该设备只能使用产品上标明的电源。设备必须使用有地线的供电系统供电。第三条线（地线）是安全设施，不能不用或跳过。

拔掉电源 • 为安全地从设备拔掉电源，请拔掉所有设备后或桌面电源的电源线，或任何接到市电系统的电源线。

电源线保护 • 妥善布线，避免被踩踏，或重物挤压。

维护 • 所有维修必须由认证的维修人员进行。设备内部没有用户可以更换的零件。为避免出现触电危险不要自己试图打开设备盖子维修该设备。

通风孔 • 有些设备机壳上有通风槽或孔，它们是用来防止机内敏感元件过热。不要用什么东西挡住通风孔。

锂电池 • 不正确的更换电池会有爆炸的危险。必须使用与厂家推荐的相同或相近型号的电池。按照生产厂家的建议处理废弃电池。

FCC Class B Notice

This equipment has been tested and found to comply with the limits for a Class B digital device, pursuant to part 15 of the FCC Rules. These limits are designed to provide reasonable protection against harmful interference in a residential installation. This equipment generates, uses, and can radiate radio frequency energy and, if not installed and used in accordance with the instructions, may cause harmful interference to radio communications. However, there is no guarantee that the interference will not occur in a particular installation. If this equipment does cause harmful interference to radio or television reception, which can be determined by turning the equipment off and on, the user is encouraged to try to correct the interference by one or more of the following measures:

- Reorient or relocate the receiving antenna.
- Increase the separation between the equipment and receiver.
- Connect the equipment into an outlet on a circuit different from that to which the receiver is connected.
- Consult the dealer or an experienced radio/TV technician for help.

NOTE: This unit was tested with shielded cables on the peripheral devices. Shielded cables must be used with the unit to ensure compliance.

Conventions Used in this Guide

WARNING: A warning indicates a situation that has the potential to result in death or severe injury.

ATTENTION: Attention indicates a situation that may damage or destroy the product or associated equipment.

NOTE: A note draws attention to important information.

Specifications Availability

Product specifications are available on the Extron website, www.extron.com.

Copyright

© 2012 Extron Electronics. All rights reserved.

Trademarks

All trademarks mentioned in this manual are the properties of their respective owners.

Contents

Introduction 1

- About this Manual..... 1
- Terms Used in this Manual 1
- Features..... 1

Installation 3

- Application Examples..... 3
- Mounting the XPA 1002 and XPA 2001 4
 - Tabletop Use 4
 - UL Guidelines for Rack Mounting..... 4
 - Rack Mounting 5
 - Flexible Conduit Adapter Kit Installation..... 6

Operation..... 9

- Front Panel Features and Operation 9
- Rear Panel Features and Operation..... 11
 - Remote Volume Control..... 17
 - Controlling Multiple Amplifiers with One
Volume Controller..... 18
 - Bridged Mono Output..... 19
- Troubleshooting 20
 - Amplifier Fails to Exit
Standby Mode Promptly..... 20
 - Amplifier Enters Standby Mode
Too Early 20
 - Limiter/Protect LED Warning Indicators..... 21
 - Over Temp Indicator LED 21

References 20

- Part Numbers and Accessories..... 20
 - Included Parts 20
 - Optional Accessories 20

Introduction

About this Manual

This manual contains information about the Extron XTRA Series of power amplifiers.

- XPA 1002 two-channel stereo audio power amplifier
- XPA 2001-70V mono audio power amplifier
- XPA 2001-100V mono audio power amplifier

Terms Used in this Manual

The terms “amplifier” and “power amplifier” are used interchangeably in this manual to refer to all of the XPA models. XPA 2001 refers to both the XPA 2001-70V and the XPA 2001-100V.

Features

Inputs — Balanced or unbalanced stereo or mono on a 3.5 mm, 5-pole captive screw connector.

Speaker outputs — Screw-lock, 5 mm captive screw connectors enable simple, secure connections with 22 AWG to 12 AWG speaker cables.

Continuous power output for larger rooms —

- XPA 1002: 60 watts rms per channel at 8 ohms; 100 watts rms per channel at 4 ohms.
- XPA 2001-70V: 200 watts rms for 70 volt speaker systems.
- XPA 2001-100V: 200 watts rms for 100 volt speaker systems.

Professional grade amplifier design —

- The XPA 1002 features less than 0.05% total harmonic distortion plus noise, and better than 105 dB signal-to-noise ratio.
- The XPA 2001 features less than 0.1% total harmonic distortion plus noise, and better than 100 dB signal to noise ratio.

ENERGY STAR® qualified amplifier — The XTRA Series of amplifiers are energy efficient products that conserve energy and reduce operating costs.

Highly efficient Class D amplifier design — The XTRA Series of amplifiers generate substantially less heat than conventional amplifier designs, making them ideal for installation in equipment racks and lecterns with very limited ventilation. They consume 10 watts when idle and less than 1 watt in standby mode.

Extron patented CDRS™ - Class D ripple suppression — A patented, exclusive technology from Extron that eliminates the high frequency switching ripple and EMI emissions found in typical Class D amplifiers. CDRS enables Extron power amplifiers to be situated near wireless AV devices without RF interference.

Convection cooled — The XTRA Series of amplifiers are convection cooled without the need for fans, ensuring quiet, reliable operation.

Ultra low inrush current - no need for power sequencing — Allows many XTRA Series amplifiers to be powered on simultaneously without overloading power circuits. This eliminates the need for power sequencing.

Flexible Conduit Adapter Kit, part # 70-228-02 — Suitable for use in other environmental air space in accordance with section 300.22, (C) of the National Electrical Code only when used with optional Flexible Conduit Adapter Kit.

Auto-standby with fast power-up — The amplifiers automatically enter into a standby mode after 25 minutes of inactivity, + or - 5 minutes, dramatically reducing power consumption. They quickly return to full power status upon signal detection.

Rear panel attenuation (level) controls — Provide attenuation of input signals for setting proper audio system gain staging as well as two-zone applications. They are located on the rear panel to prevent unauthorized or accidental tampering of the level adjustments.

Multiple protection circuits — Activates during excessive clipping, output shorts, thermal overload, or DC faults to prevent damage to the amplifier and speakers.

Remote standby port — Enables the amplifiers to be remotely powered down when not in use, reducing operating cost.

Remote volume and mute control port — This port allows the amplifiers to be remotely controlled using the optional Extron VCM 100 Series volume and mute or VC 50 volume controllers.

Bridgeable outputs — The power output of the XPA 1002 can be effectively doubled by bridging the output. A mono source is wired to both the left and right input while the output is wired for bridged operation. Bridging allows power to be output at 200 watts into 8 ohms. The minimum load impedance when bridging is 8 ohms. See the wiring instructions beginning on [page 19](#).

Front and rear-mounted signal and protection indication LEDs — Provide convenient indication of amplifier operation from both sides of an equipment rack.

Internal international power supply — The 100-240 VAC, 50-60 Hz universal power supply provides worldwide power compatibility.

Installation

This section discusses how to install the XTRA Series of audio power amplifiers. Topics that are covered, include:

- **Application Examples**
- **Mounting the XPA 1002 and XPA 2001**

WARNING: Failure to follow these instructions may result in serious injury. Installation and service must be performed by authorized personnel only. See "UL Guidelines for Rack Mounting" on page 4.

Application Examples

The following illustrations are application examples for the XPA 1002 and the XPA 2001.

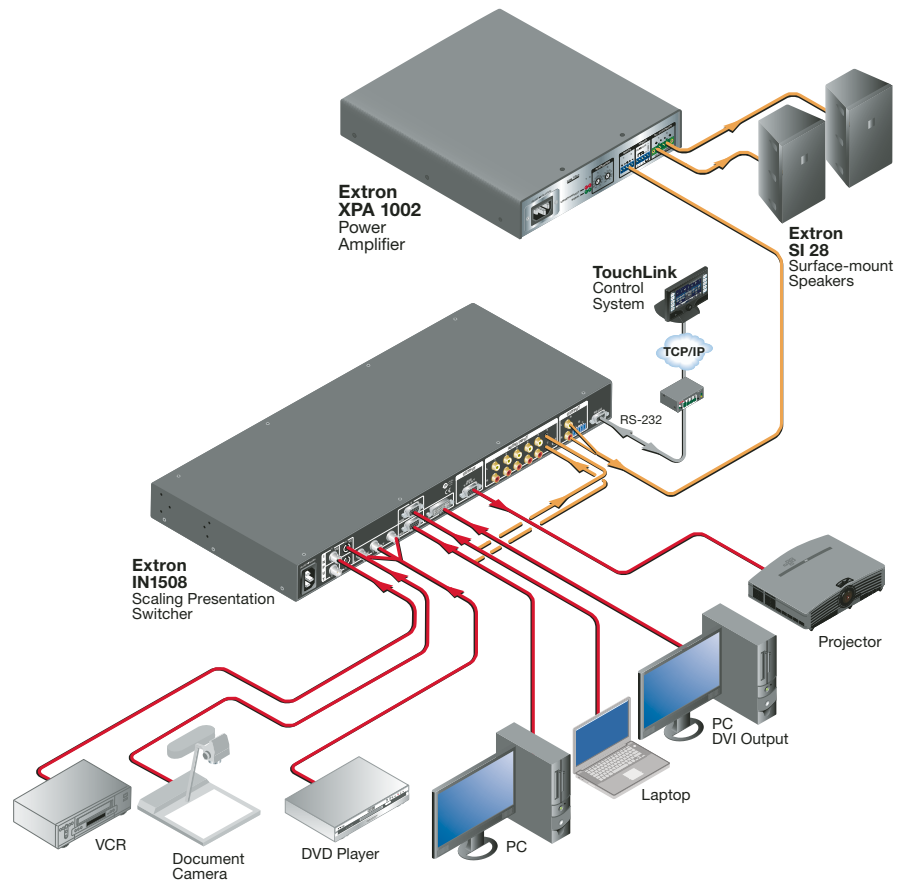

Figure 1. XPA 1002 Application Example

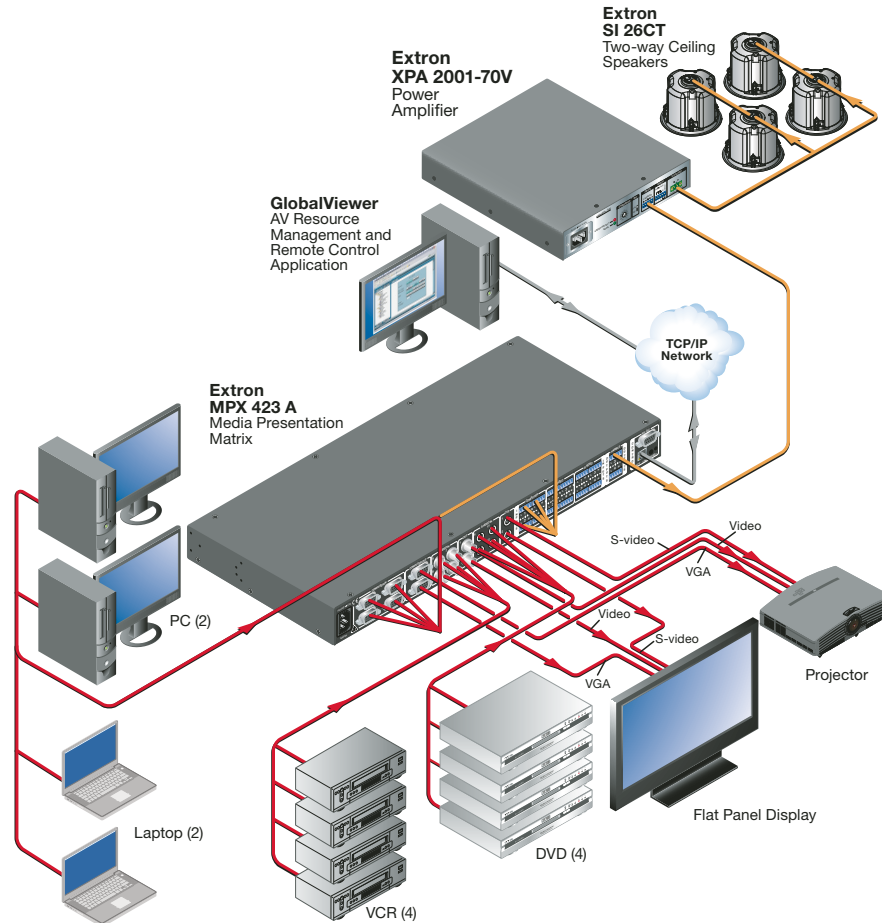

Figure 2. XPA 2001 Series Application Example

Mounting the XPA 1002 and XPA 2001

The XPA 1002 and XPA 2001 audio amplifiers can be set on a table, mounted on a rack shelf, or mounted in the plenum space above a ceiling-mounted projector.

Tabletop Use

Four self-adhesive rubber feet are included with the audio amplifier.

For tabletop use, attach one foot at each corner of the bottom side of the unit and place the unit in the desired location.

UL Guidelines for Rack Mounting

The following Underwriters Laboratories (UL) guidelines pertain to the installation of the equipment in a rack.

- 1. Elevated operating ambient** — If installed in a closed or multi-unit rack assembly, the operating ambient temperature of the rack environment may be greater than room ambient. Therefore, consider installing the equipment in an environment compatible with the maximum ambient temperature specified by the manufacturer [T_{ma} = +32 to +122 °F (0 to +50 °C)].
- 2. Reduced air flow** — Installation of the equipment in a rack should be such that the amount of air flow required for safe operation of the equipment is not compromised.

3. **Mechanical loading** — Mounting of the equipment in the rack should be such that a hazardous condition is not achieved due to uneven mechanical loading.
4. **Circuit overloading** — Consideration should be given to the connection of the equipment to the supply circuit and the effect that overloading of the circuits might have on overcurrent protection and supply wiring. Appropriate consideration of equipment nameplate ratings should be used when addressing this concern.
5. **Reliable earthing (grounding)** — Reliable earthing of rack-mounted equipment should be maintained. Particular attention should be given to supply connections other than direct connections to the branch circuit (such as the use of power strips).

Rack Mounting

The XPA 1002 or XPA 2001 can be mounted in a rack shelf using the optional RSU 129 1U Universal rack shelf (Extron part #60-190-01) or the 1U Basic rack shelf (Extron part #60-604-02), as follows.

1. If feet were installed on the bottom of the amplifier, remove them.
2.
 - Place the amplifier on one half of the rack shelf.
 - Align the front of the amplifier with the front of the shelf, and align the threaded holes on the bottom of the amplifier with the holes in the rack shelf.
3.
 - Attach the amplifier to the rack shelf with the two provided 4-40 x 3/16" machine screws.
 - Insert the screws from the underside of the shelf, and securely fasten them into diagonally-opposite corners.

See the following illustration.

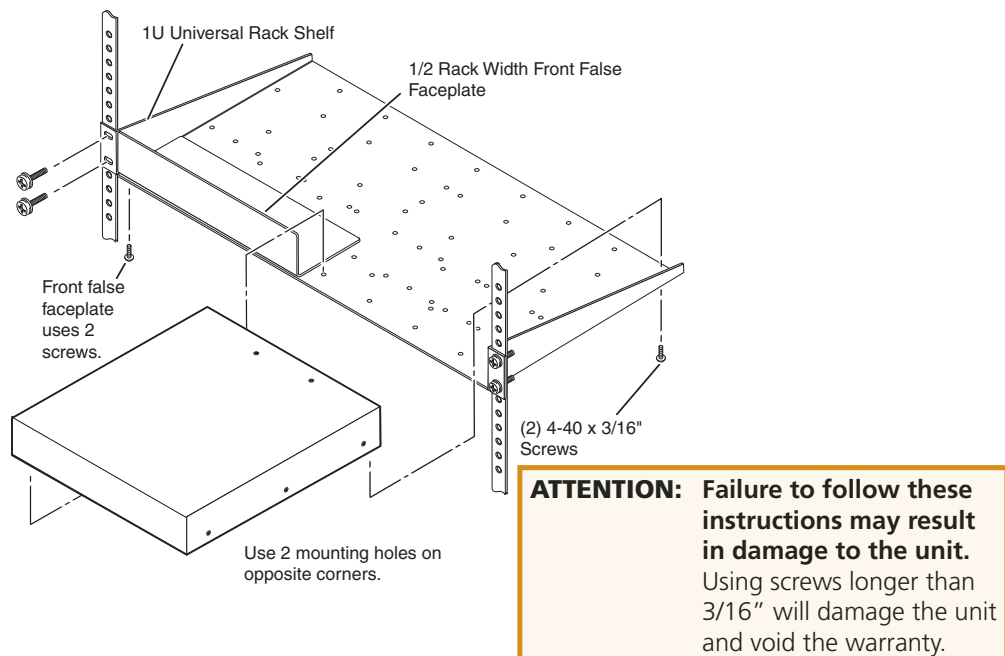

Figure 3. Rack Mounting of the Amplifier

4. Attach the false front panel (provided with rack shelf part #60-190-01) to the unoccupied side of the rack (as shown above), or install a second half-rack-width device in that side by repeating steps 1 through 3.
5. Attach the rack shelf to the rack using four 10-32 x 3/4" bolts (provided). Insert the bolts through #10 beveled washers, then through the holes in the rack, as shown above.

Rack Mounting Ventilation Recommendations

Excessive heat can decrease the optimal lifetime of the power amplifier. An over temp indicator LED on the front panel of the amplifier lights red whenever the recommended operating temperature has been exceeded. See “[Front Panel Features and Operation](#)” on page 9.

To reduce the chances for an over temp condition, the XPAs should be arranged in a rack environment so that adequate airflow is available both above and below the XPA whenever possible. No more than two XPAs should be arranged one-on-top-of-the-other in a rack without an open space between them, as shown in the following illustration. An XPA can also be arranged above or below another non-XPA device, but there must be an open space both above and below those devices.

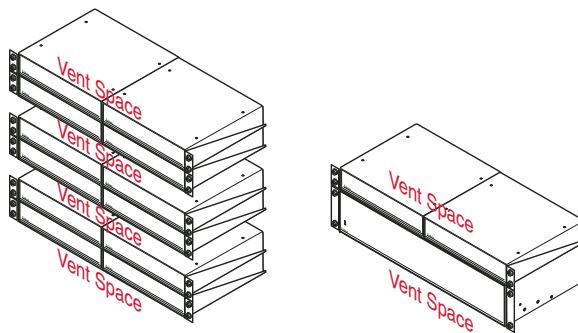

Figure 4. Allow Sufficient Spacing for Adequate Ventilation

Flexible Conduit Adapter Kit Installation

WARNING: Failure to follow these instructions may result in serious injury.

The circuit breaker used for this connection should be rated no lower than 20 amps and no greater than 30 amps.

This unit must be installed in accordance with the National Electrical Code and with all local codes.

An ALL-POLE MAINS SWITCH with a contact separation of at least 3 mm in each pole shall be incorporated in the electrical installation of the building. The installation shall be carried out in accordance with all applicable installation rules.

Installation and service must be performed by a qualified electrician only.

ATTENTION: Failure to follow these instructions may result in damage to the unit.

A UL listed electrical distribution box is recommended for the termination of the conduit opposite the XPA. See the following “[UL Requirements](#)” section on page 7.

The optional Flexible Conduit Adapter Kit (Extron part #70-228-02) consists of

- One EMT adapter plate
- One 6-foot long electrical conduit
- Three 7.5 feet, 18-gauge spade connector power wires
- One UL rated zip tie wrap
- Three auxiliary crimp style spade connectors designed for 14- to 16-gauge wires

NOTE: If needed, Extron recommends using a UL-rated crimp tool to terminate the spade connectors. One recommended choice is the Molex crimp tool (Molex part #64001-0100).

The kit provides a convenient means to replace the XPA's IEC power cord with conduit, where required by local codes.

WARNING: Failure to follow these instructions may result in serious injury. Make sure that the source device and the XPA are turned off and disconnected from the power source before you begin.

UL Requirements

The Underwriters Laboratories (UL) requirements listed below pertain to the installation of the flexible conduit onto a XPA 1002 or XPA 2001.

- This unit is not to be used beyond its rated voltage range.
- This unit must be wired to a UL listed distribution box.

NOTE: The UL approved electrical distribution box is not included with either the XPA or the Flexible Conduit Adapter Kit; the installer is responsible for obtaining and installing the box.

Installing the Flexible Conduit Kit

Install flexible conduit to the XPA by following the steps below.

1. Unplug the IEC power cord from the power amplifier.
2. Remove the 8 screws from the top and sides of the XPA and lift off the cover. See the following illustration.

ATTENTION: Failure to follow these instructions may result in damage to the unit. Electrostatic discharge (ESD) can damage IC chips even though you cannot feel it. You must be electrically grounded before touching anything inside the XPA. A grounding wrist strap is recommended.

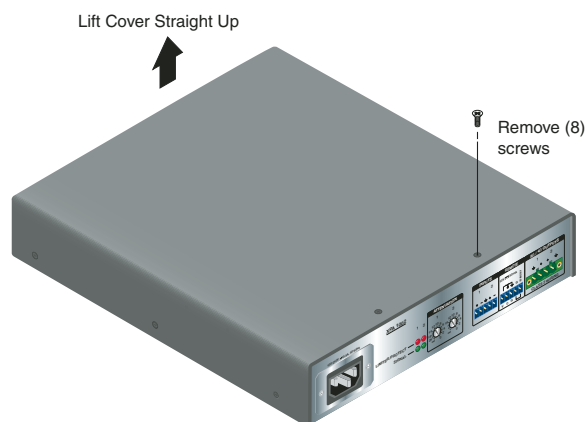

Figure 5. Removing the Cover

3. Remove the 2 screws holding the hot (line) and neutral wires from the terminal block on the PCB.

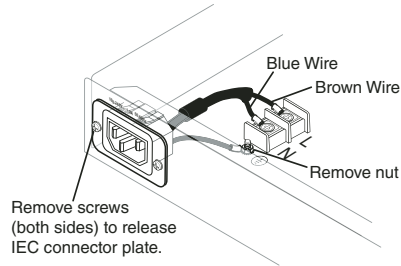

Figure 6. Removing the IEC Connector

4. Remove the ground wire nut from the grounding stud on the bottom of the enclosure, as shown above.
5. Remove the 2 screws from the IEC plate, and remove the IEC connector plate and the attached wires through the rear panel of the XPA, as shown above.
6. Thread the 18-gauge power wires through the length of the electrical conduit tube.
7. Install the EMT adapter plate with conduit attached into the opening from which the IEC connector was removed in step 5.
8. Slide the conduit nut over the bundle of wires exiting the conduit and onto the conduit itself. Hand tighten the conduit nut to the conduit.
9. Attach the EMT adapter plate assembly to the XPA using the 2 screws that were removed in step 5.
10. Connect the black hot (line) and white neutral wires to the terminal block on the PCB using the 2 screws that were removed in step 3. Use the included zip tie wrap to secure the two wires together close to the terminals. See the following illustration.

WARNING: Failure to follow these instructions may result in serious injury. Ensure that you observe correct wire polarity. The following illustration shows the location of the hot (L) and neutral (N) terminals.

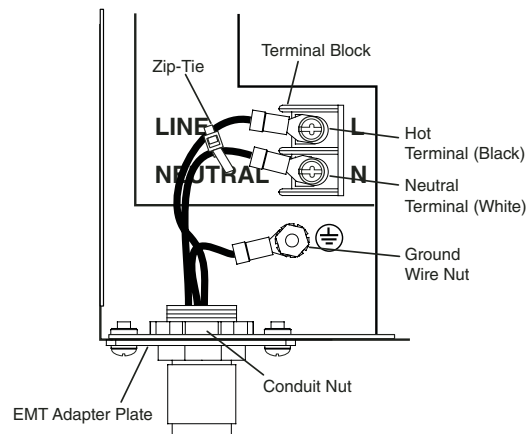

Figure 7. Installing the EMT Adapter Plate Assembly

11. Connect the ground wire, as shown above, to the grounding stud on the bottom of the enclosure using the nut that was removed in step 4.
12. Replace the cover of the XPA by attaching the 8 screws that were removed in step 2.

Operation

This section discusses how to operate the XTRA Series of audio power amplifiers. Topics that are covered, include:

- **Front Panel Features and Operation**
- **Rear Panel Features and Operation**

Front Panel Features and Operation

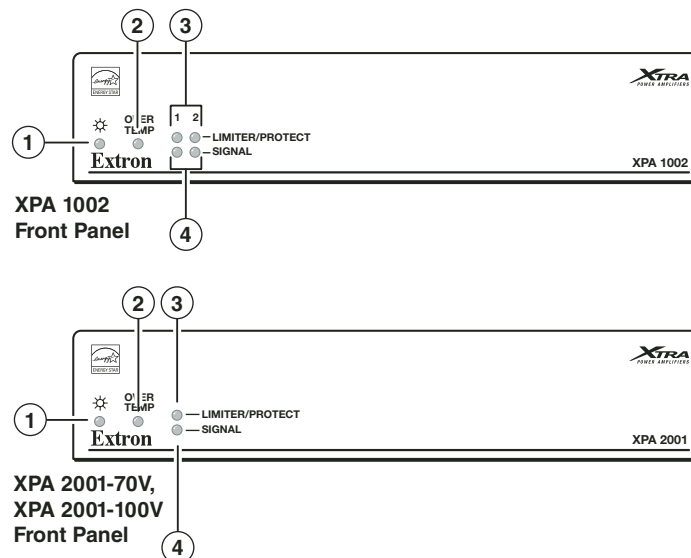

- ① **Power indicator LED** — This LED lights:
 - Green when the amplifier is receiving full power.
 - Amber when the amplifier is in Standby mode. Standby mode turns off all outputs from the amplifier, although the amplifier is still receiving power. See ⑥ of “**Rear Panel Features and Operation**” on page 13.
- ② **Over Temp indicator LED** — This LED lights red when the amplifier exceeds the recommended operating temperature for optimal lifetime. The LED will turn off after the amplifier has cooled down sufficiently.

Should the LED light, check the following:

- Verify that the placement of the amplifier allows for adequate ventilation and airflow.
- Avoid placing other equipment on top of the amplifier.
- Verify that the operating temperature is within the specified range.

- ③ **Limitier/Protect indicator LEDs (channels 1 and 2)** — These LEDs (representing output channels 1 and 2) light red under three circumstances:

1 2
● ● — **LIMITER/PROTECT**

- When the output wiring is shorted together
- When audio clipping occurs, the corresponding channel's LED blinks once per clip occurrence.
- When the amplifier overheats, both LEDs are lit. The LEDs are not lit after the amplifier recovers from the overheated condition.

NOTE: These LEDs are also located on the rear panel.

- ④ **Signal indicator LEDs (channels 1 and 2)** — These LEDs (representing input channels 1 and 2) light green only when an input signal is detected on the corresponding channel.

1 2
● ● — **SIGNAL**

NOTE: These LEDs are also located on the rear panel.

Rear Panel Features and Operation

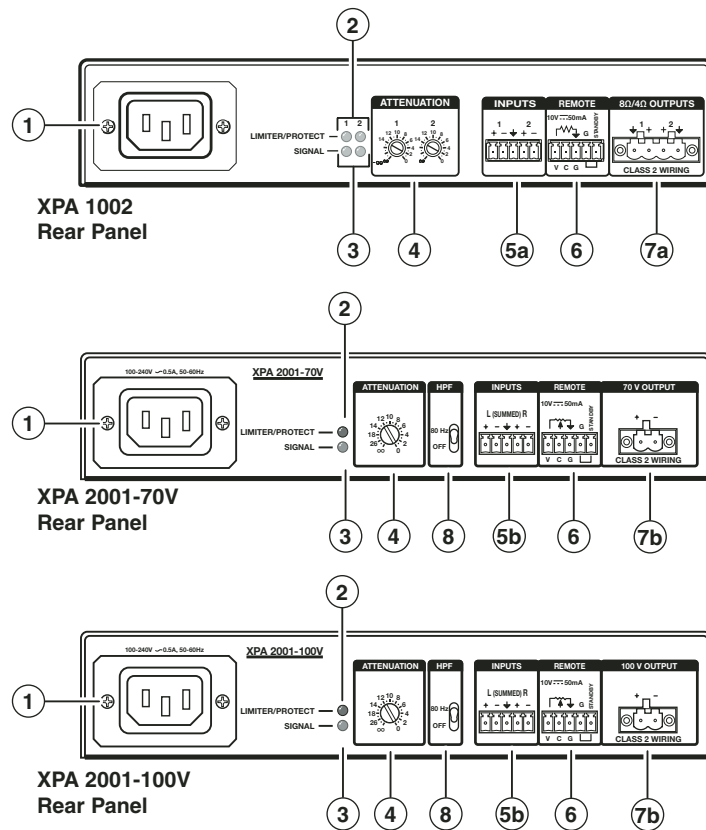

NOTE: Control signal ground pins may be labeled as \oplus or "G". Audio ground pins may be labeled as \oplus or \downarrow . The wiring and function are the same, whichever way your product is labeled.

- ① **AC power connector** — Connect a standard IEC AC power cord here for power input (100 VAC to 240 VAC, 50/60 Hz) to the internal, autoswitching power supply. This connector may be replaced by the Flexible Conduit Adapter Kit (part #70-228-02) as described in "**Flexible Conduit Adapter Kit Installation**" on page 6.
- ② **Limiter/Protect indicator LEDs** — These LEDs light red under certain circumstances.

NOTE: See ③ of "**Front Panel Features and Operation**" on page 10 for more details.

- ③ **Signal indicator LEDs** — These LEDs light green only when an input signal is detected on the corresponding channel.

NOTE: See ④ of "**Front Panel Features and Operation**" on page 10 for more details.

- ④ **Attenuation (channels 1 and 2)** — Use a small screwdriver to adjust the audio input level for the corresponding channel. The analog potentiometers control the level from ∞ (full attenuation) to 0 dB.

NOTES:

- On the XPA 2001, the single control adjusts the levels of both channels simultaneously prior to summing them together.
- On some models, this adjustment is referred to as “level”. The function is the same, whichever way your product is labeled.

To adjust the input level of the XPA amplifier, do the following:

1. If connecting to a source device with a volume control (variable output), ensure that the volume on the source device is set to its lowest point, then adjust the level of the XPA fully counterclockwise.
2. Set the source device’s volume to its maximum volume level. No sound should come out.
3. Return to the XPA amplifier and raise the level until sound distortion occurs, then lower the level slightly until any distortion disappears. This setting ensures that, whatever the source device volume setting may be, no clipping occurs.

NOTE: When setting volume control through a source device, ensure that the volume of the device is set to variable out. Consult the user manual of the device for detailed instructions on its calibration.

- ⑤a **Balanced or unbalanced stereo or mono audio input connector (XPA 1002)** — Wire the 3.5 mm 5-pin captive screw connector for balanced or unbalanced input.

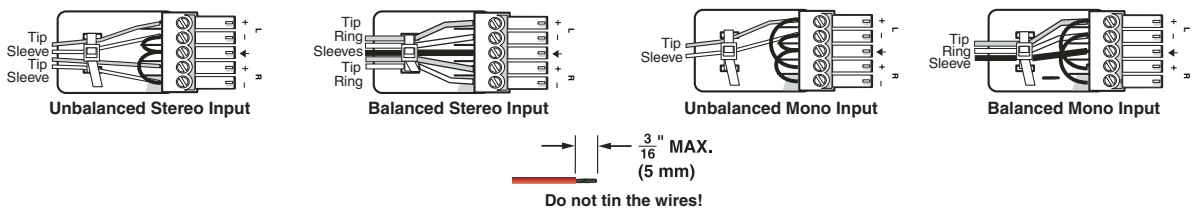

NOTE: The input connector port may be labeled one of two ways. The wiring and function are the same, whichever way your product is labeled.

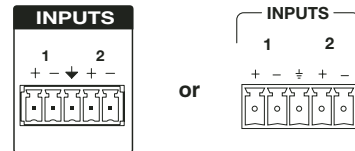

NOTE: The output power of the XPA 1002 can be effectively doubled by using only one input channel and bridging the output. The XPA 1002 will output 200 watts @ 8 ohms in bridged mode. See “**Bridged Mono Output**” on page 19 for wiring instructions when bridging the XPA 1002.

5b) Balanced or unbalanced stereo or mono audio input connector (XPA 2001) —
Wire the 3.5 mm 5-pin captive screw connector for balanced or unbalanced input.

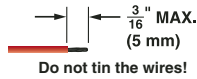
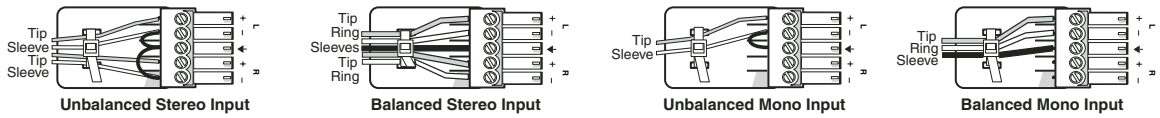

NOTE: The input connector port may be labeled one of two ways. The wiring and function are the same, whichever way your product is labeled.

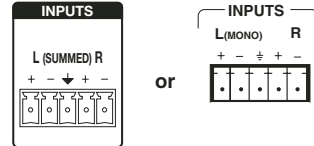

NOTE: For mono input on the XPA 2001, because the left and right channels are summed, only the left channel needs to be wired. No jumpering to the right channel is needed.

6) Remote control connector — The 3.5 mm 5-pin captive screw receptacle is used to remotely control two functions through contact closure: See the following circuit diagram.

NOTE: The remote control port may be labeled one of two ways (see the following images). The wiring and function are the same, whichever way your product is labeled.

Pins V, C, and G (1, 2, and 3) control volume by varying the DC voltage from 0 V (full attenuation) to 10 V (maximum volume) with full muting in effect when pin C is connected to ground (pin G). Use the included 3-pin captive screw connector. See "[Remote Volume Control](#)" on page 17.

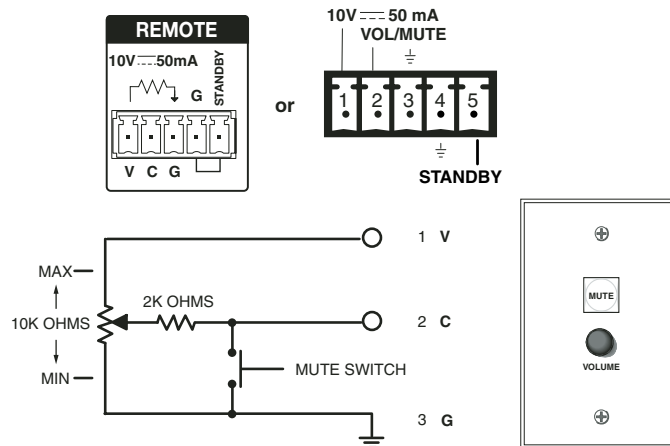

- Pin 5 connected to ground (pin 4) places the amplifier in standby mode. Standby mode turns off all output, although the amplifier is still receiving power. Use the included 2-pin, 3.5 mm captive screw connector to remotely ground pin 5.

The power indicator LED lights amber when the amplifier is in standby mode.

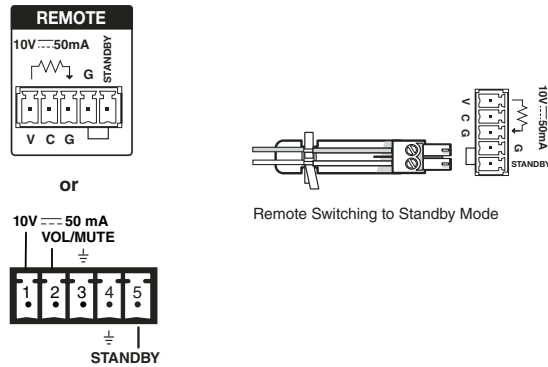

- 7a) Stereo audio output connector (channels 1 and 2)** — Marked “1” and “2” for the output channels, wire the included 4-pole, 5 mm screw lock captive screw connector to output stereo audio. Observe the correct polarities for each channel. See the following steps. The output is designed to power 4 or 8 ohm speakers and is rated at 100 watts per channel at 4 ohms and 60 watts per channel at 8 ohms.

- NOTES:**
- You must use Class 2 wiring for this output to comply with UL requirements.
 - The stereo audio output connector may be labeled one of two ways (see the images below). The wiring and function are the same, whichever way your product is labeled.

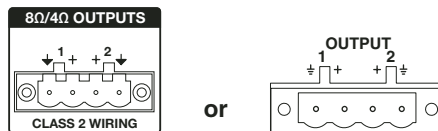

XPA 1002

- ATTENTION:** Failure to follow these instructions may result in damage to the unit.
Do not tie channel outputs 1 and 2 to each other or to ground. Doing so will short out the outputs and/or damage the amplifier.

- NOTE:** The output power of the XPA 1002 can be effectively doubled by using only one input channel and bridging the output. The XPA 1002 will output 200 watts at 8 ohms in bridged mode. See “**Bridged Mono Output**” on page **19** for wiring instructions when bridging the XPA 1002.

To wire the stereo audio output connector:

Step 1: Strip and insert the speaker wires into the connector and tighten the captive screws. Be sure to observe the correct polarity.

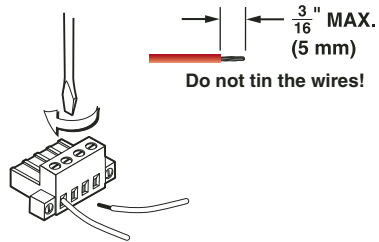

Step 2: Insert the wired connector into the amplifier output and secure the locking screws on either side.

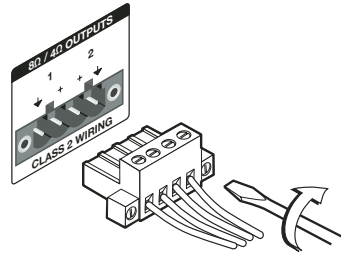

7b **Mono audio output connector** — Marked "+" and "-", wire the included 2-pole, 5 mm screw lock captive screw connector for mono audio. See the following steps on the next page. Output is designed to power 70 V (XPA 2001-70V) or 100 V (XPA 2001-100V) line distribution systems and is rated at 200 watts.

- NOTES:**
- You must use Class 2 wiring for this output to comply with UL requirements.
 - The mono audio output connector may be labeled one of two ways (see the images below). The wiring and function are the same, whichever way your product is labeled.

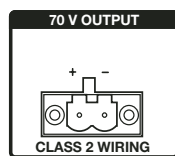

XPA 2001-70V

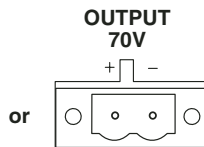

or

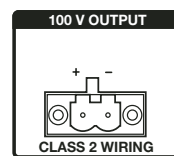

XPA 2001-100V

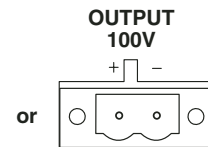

or

ATTENTION: Failure to follow these instructions may result in damage to the unit.

Do not tie channel outputs 1 and 2 to each other or to ground. Doing so will short out the outputs and/or damage the amplifier.

To wire the mono audio output connector:

Step 1: Strip and insert the speaker wires into the connector and tighten the captive screws. Be sure to observe the correct polarity.

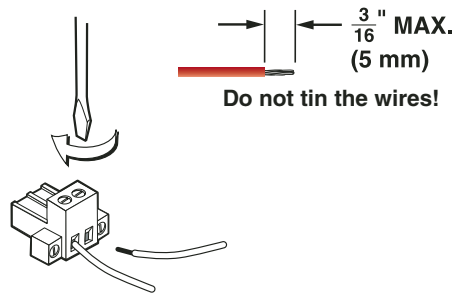

Step 2: Insert the wired connector into the amplifier output and secure the locking screws on either side.

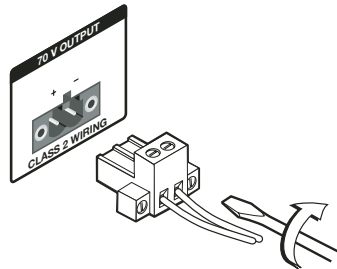

- ⑧ **High pass filter toggle switch** — Use a small screwdriver to toggle this recessed two-position toggle switch that alternates between Off (no filtering) and 80 Hz (default). Setting the switch to 80 Hz prevents the saturation of 70 V/100 V speaker input transformers by low frequency signals. Saturation can result in severe distortion of the speaker output signal.

NOTES:

- The high-pass filter may be safely turned off if it is applied to the source input signal upstream of the amplifier. Otherwise, it should be left on.
- The high-pass filter toggle switch may be labeled one of two ways. The wiring and function are the same, whichever way your product is labeled.

Remote Volume Control

Options for remote control of the XPA amplifiers include the Extron VCM 100 and VC 50 volume controllers. Third party 10k potentiometer volume controllers can also be connected to this port.

As shown in the following illustration, pin V (1) on the XPA is a 10 VDC reference voltage. Pin C (2) is the volume control DC voltage input. The range is 0 to 10 V, where 0 V is mute and 10 V provides maximum volume. Pin G (3) is ground.

NOTE: All nominal levels are at $\pm 10\%$.

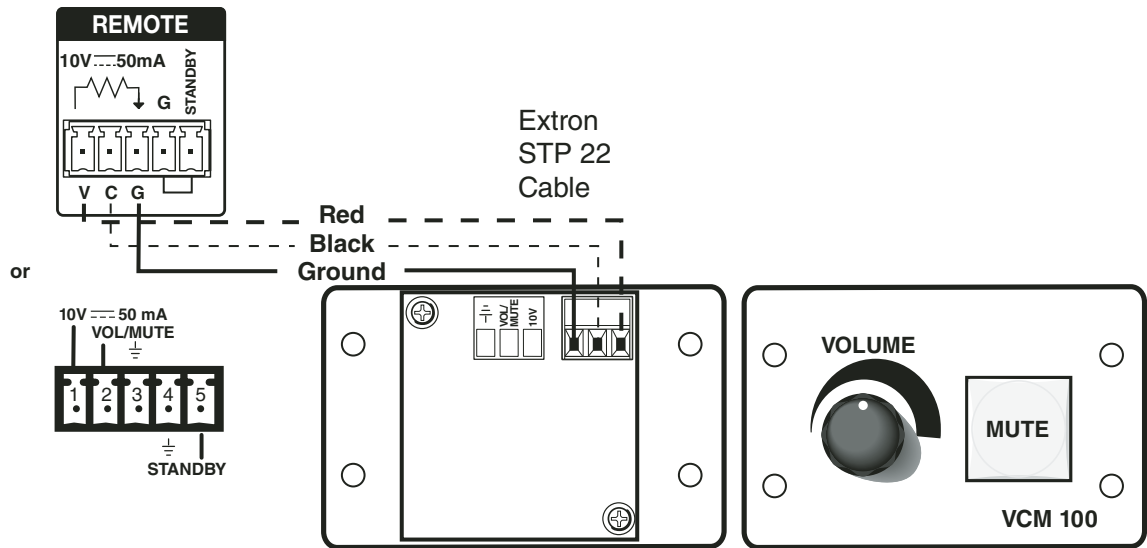

Figure 8. Pinout Diagram for VCM 100 MAAP Connection to XPA Remote Connector

Controlling Multiple Amplifiers with One Volume Controller

Several XPA 1002 and XPA 2001 units can be daisy-chained so that one volume controller can simultaneously regulate the volume of all the amplifiers.

- NOTES:**
- As additional amplifiers are added to the daisy chain, the sensitivity of the volume potentiometer will change. The maximum volume level (fully clockwise) will not be affected. However, the effectiveness of the minimum volume level (fully counterclockwise) in reducing the volume to inaudible levels decreases as more amplifiers are added to the daisy chain.
 - When more than two XPA Half-Rack units are attached to the chain, sound may be heard even if the levels have been set to their lowest. The muting of the output, however, can be remedied with a contact closure attached between the Vol/Mute and the Ground pin of the first XPA Half-Rack unit in the chain.

To regulate multiple amplifiers with a single volume controller:

1. Attach all three pins of the volume controller to the corresponding pins on the first XPA Half-Rack unit only — Ground to G (ground), Vol/Mute to C (Vol/Mute), and 10 V to V (10 V).
2. Use jumper wires to connect the C (Vol/Mute) pins of the first amplifier and each successive amplifier.
3. Use jumper wires to connect the G (ground) pins of the first amplifier and each successive amplifier.

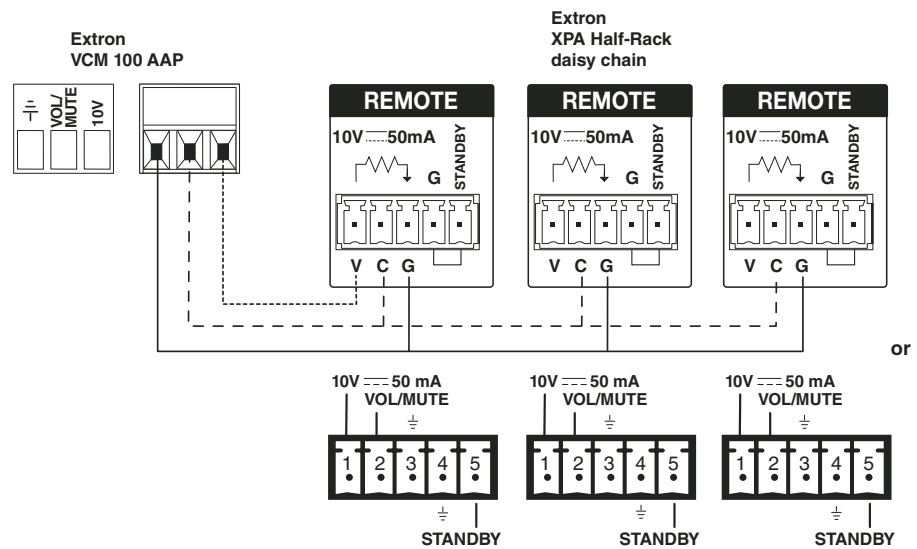

Figure 9. Regulating Multiple Amplifiers with a Single Volume Controller

NOTE: The 10 V pin of the volume controller connects to the first XPA Half-Rack unit only. There are no jumper wires linking it to subsequent amplifiers.

Bridged Mono Output

The power output of the XPA 1002 can be effectively doubled by bridging the output. Bridging allows power to be output in mono at 200 watts at 8 ohms.

- NOTES:**
- The bridging instructions that follow apply only to the XPA 1002 model.
 - The minimum load impedance when bridging is 8 ohms.

To bridge the output, follow the steps and refer to the diagram below:

1. Unplug the IEC power cord from the power amplifier.
2. Fully attenuate the potentiometer.
3. Wire the output as shown in the following diagram.
4. Wire the input as shown in the following diagram.
5. Connect the IEC power cord and power up the amplifier.
6. Adjust the input levels of channels 1 and 2 identically.

See ④ (Attenuation) of “**Rear Panel Features and Operation**” on page 12 for more details.

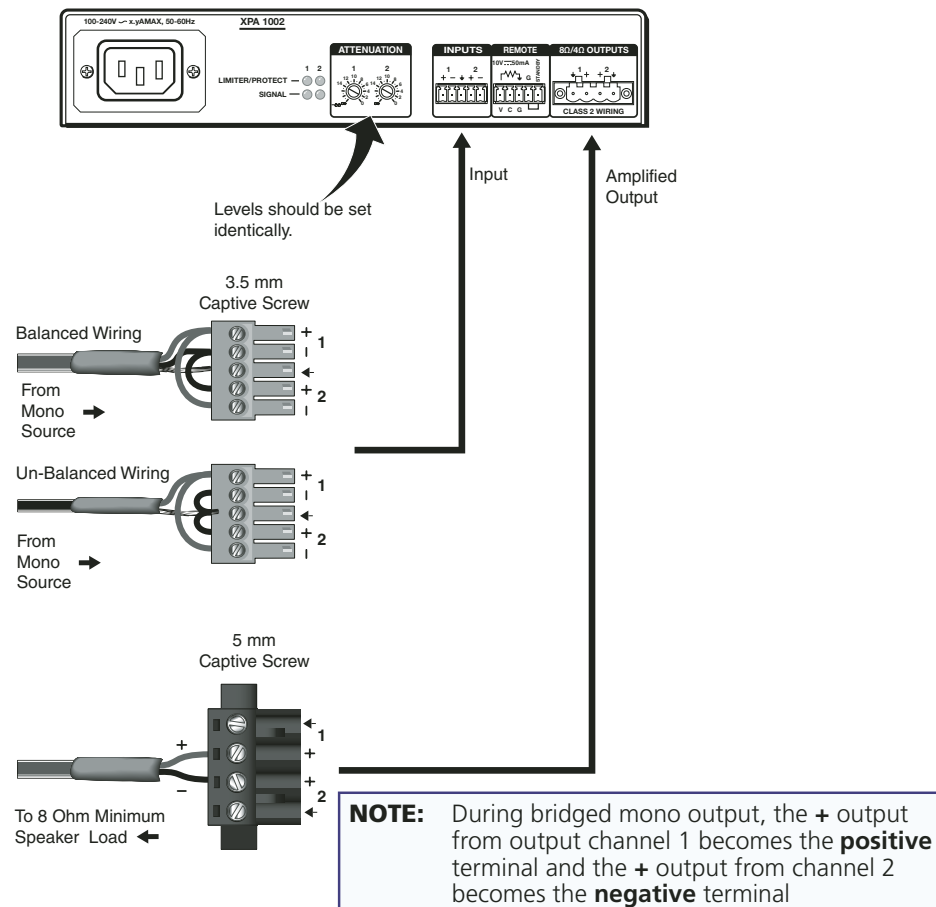

Figure 10. Bridging the Output of the XPA 1002

Troubleshooting

The front and rear panels have LED warning indicators, as described in the following diagnostic information.

Amplifier Fails to Exit Standby Mode Promptly

The input channel (channels 1 and 2) Signal LED lights green per indicated input channel when an input signal is detected.

Power LED Color	Signal LED State	Problem Description	Problem Solution
Amber	Not lit	No output signal	No input detected, verify the input signal. If input is present, raise input level until signal LED lights.
Green or Amber	Lit intermittently	Slow to promptly exit standby mode with signal present.	The output signal level of the source may be too low to cross the signal detection threshold of the amplifier (see amplifier specifications for details). Increase the signal level of the source until the signal LED lights consistently.
Amber	Lit	No output signal	Amplifier has been placed in standby mode and output has been turned off. Check remote port. DC fault may have been detected (see below).
Amber	Lit	DC Fault is detected on either channel. Unit does not exit standby.	Disconnect power then disconnect the remote port (if connected). Next, reconnect power to the unit to determine if the unit continues to go into immediate standby upon power up. In such a case, the unit should be serviced.

Amplifier Enters Standby Mode Too Early

The input channel (channels 1 and 2) Signal LED lights green per indicated input channel when an input signal is detected.

Power LED Color	Signal LED State	Problem Description	Problem Solution
Green or Amber	Lit intermittently	Enters standby mode early.	The output signal level of the source may be too low to cross the signal detection threshold of the amplifier (see amplifier specifications for details). Increase the signal level of the source until the signal LED lights consistently.

Limiters/Protect LED Warning Indicators

The output channel (channels 1 and 2) Limiter/Protect LED lights red per indicated output channel as shown in the following diagnostic information.

LED State	Problem Description	Problem Solution
Blinks	Audio clipping is occurring at the rate of one blink per clip.	Reduce the power output to avoid overdriving the amplifier and causing clipping.
Lights steady	The amplifier may be overheating.	Determine the reason for the overheated state and allow the amplifier to cool. The LED will not be lit after the amplifier recovers from the overheated state.
	Output channel leads are shorted	Check speakers and speaker wiring for shorts.

Over Temp Indicator LED

This indicator does not represent a hard failure of the unit. It is meant as a warning that the amplifier has exceeded the recommended operating temperature for optional product lifetime.

LED State	Problem Description	Problem Solution
Lights steady	Amplifier has exceeded the recommended operating temperature. The LED turns off after the amplifier cools down sufficiently.	<ul style="list-style-type: none">• Verify that the placement of the amplifier allows for adequate ventilation and airflow.• Avoid placing equipment on top of the amplifier.• Verify that the operating temperature is within the specified range.

References

This section discusses the part numbers and accessories for the XTRA Series of half-rack audio power amplifiers.

Part Numbers and Accessories

Included parts

Included parts	Replacement part number
XPA 1002 two-channel power amplifier	60-849-01
or	
XPA 2001-70V single-channel power amplifier	60-850-01
or	
XPA 2001-100V single-channel power amplifier	60-850-11
(1) 4-pole screw lock 5.08 mm captive screw plug (XPA 1002)	100-464-01
(1) 2-pole screw lock 5.08 mm captive screw plug (XPA 2001-70V/100V)	100-463-01
(1) 5-pole 3.5 mm captive screw plug	100-457-01
(1) 3-pole 3.5 mm captive screw plug	100-456-01
(1) 2-pole 3.5 mm captive screw plug	100-455-01
(4) rubber feet (detached)	
IEC power cord	
Setup Guide	

Optional Accessories

Accessories	Part number
RSU 129 9.5" deep 1U universal rack shelf kit	60-190-01
RSB 129 9.5" deep 1U basic rack shelf	60-604-02
MLA VC10 Plus volume control module	60-1090-01
VCM 100 AAP volume and mute control	70-396-11, -21
VCM 100 MAAP volume and mute control	70-397-11, -21, -51
VC 50 volume control wall plate	70-530-02
Flexible conduit adapter kit	70-228-02

Extron Warranty

Extron Electronics warrants this product against defects in materials and workmanship for a period of three years from the date of purchase. In the event of malfunction during the warranty period attributable directly to faulty workmanship and/or materials, Extron Electronics will, at its option, repair or replace said products or components, to whatever extent it shall deem necessary to restore said product to proper operating condition, provided that it is returned within the warranty period, with proof of purchase and description of malfunction to:

USA, Canada, South America, and Central America:

Extron Electronics
1001 East Ball Road
Anaheim, CA 92805
U.S.A.

Japan:

Extron Electronics, Japan
Kyodo Building, 16 Ichibancho
Chiyoda-ku, Tokyo 102-0082
Japan

Europe and Africa:

Extron Europe
Hanzeboulevard 10
3825 PH Amersfoort
The Netherlands

China:

Extron China
686 Ronghua Road
Songjiang District
Shanghai 201611
China

Asia:

Extron Asia
135 Joo Seng Road, #04-01
PM Industrial Bldg.
Singapore 368363
Singapore

Middle East:

Extron Middle East
Dubai Airport Free Zone
F12, PO Box 293666
United Arab Emirates, Dubai

This Limited Warranty does not apply if the fault has been caused by misuse, improper handling care, electrical or mechanical abuse, abnormal operating conditions, or if modifications were made to the product that were not authorized by Extron.

NOTE: If a product is defective, please call Extron and ask for an Application Engineer to receive an RA (Return Authorization) number. This will begin the repair process.

USA: 714.491.1500 or 800.633.9876
Asia: 65.6383.4400

Europe: 31.33.453.4040
Japan: 81.3.3511.7655

Units must be returned insured, with shipping charges prepaid. If not insured, you assume the risk of loss or damage during shipment. Returned units must include the serial number and a description of the problem, as well as the name of the person to contact in case there are any questions.

Extron Electronics makes no further warranties either expressed or implied with respect to the product and its quality, performance, merchantability, or fitness for any particular use. In no event will Extron Electronics be liable for direct, indirect, or consequential damages resulting from any defect in this product even if Extron Electronics has been advised of such damage.

Please note that laws vary from state to state and country to country, and that some provisions of this warranty may not apply to you.

Extron Headquarters +1.800.633.9876 (Inside USA/Canada Only) Extron USA - West +1.714.491.1500 +1.714.491.1517 FAX Extron USA - East +1.919.850.1000 +1.919.850.1001 FAX	Extron Europe +800.3987.6673 (Inside Europe Only) +31.33.453.4040 +31.33.453.4050 FAX	Extron Asia +800.7339.8766 (Inside Asia Only) +65.6383.4400 +65.6383.4664 FAX	Extron Japan +81.3.3511.7655 +81.3.3511.7656 FAX	Extron China +4000.398766 (Inside China Only) +86.21.3760.1568 +86.21.3760.1566 FAX	Extron Middle East +971.4.2991800 +971.4.2991880 FAX	Extron Korea +82.2.3444.1571 +82.2.3444.1575 FAX	Extron India 1800.3070.3777 (Inside India Only) +91.80.3055.3777 +91.80.3055.3737 FAX
--	---	---	---	---	---	---	---

Free Manuals Download Website

<http://myh66.com>

<http://usermanuals.us>

<http://www.somanuals.com>

<http://www.4manuals.cc>

<http://www.manual-lib.com>

<http://www.404manual.com>

<http://www.luxmanual.com>

<http://aubethermostatmanual.com>

Golf course search by state

<http://golfingnear.com>

Email search by domain

<http://emailbydomain.com>

Auto manuals search

<http://auto.somanuals.com>

TV manuals search

<http://tv.somanuals.com>