

## User's Manual



# *CrossPoint Plus Matrix Switchers*

**CrossPoint Plus 84, 88, 124, 128, 168, and 1616 HV and HVA**

# Precautions

## Safety Instructions • English



This symbol is intended to alert the user of important operating and maintenance (servicing) instructions in the literature provided with the equipment.



This symbol is intended to alert the user of the presence of uninsulated dangerous voltage within the product's enclosure that may present a risk of electric shock.

### Caution

**Read Instructions** • Read and understand all safety and operating instructions before using the equipment.

**Retain Instructions** • The safety instructions should be kept for future reference.

**Follow Warnings** • Follow all warnings and instructions marked on the equipment or in the user information.

**Avoid Attachments** • Do not use tools or attachments that are not recommended by the equipment manufacturer because they may be hazardous.

## Consignes de Sécurité • Français



Ce symbole sert à avertir l'utilisateur que la documentation fournie avec le matériel contient des instructions importantes concernant l'exploitation et la maintenance (réparation).



Ce symbole sert à avertir l'utilisateur de la présence dans le boîtier de l'appareil de tensions dangereuses non isolées posant des risques d'électrocution.

### Attention

**Lire les instructions** • Prendre connaissance de toutes les consignes de sécurité et d'exploitation avant d'utiliser le matériel.

**Conservier les instructions** • Ranger les consignes de sécurité afin de pouvoir les consulter à l'avenir.

**Respecter les avertissements** • Observer tous les avertissements et consignes marqués sur le matériel ou présentés dans la documentation utilisateur.

**Éviter les pièces de fixation** • Ne pas utiliser de pièces de fixation ni d'outils non recommandés par le fabricant du matériel car cela risquerait de poser certains dangers.

## Sicherheitsanleitungen • Deutsch



Dieses Symbol soll dem Benutzer in der im Lieferumfang enthaltenen Dokumentation besonders wichtige Hinweise zur Bedienung und Wartung (Instandhaltung) geben.



Dieses Symbol soll den Benutzer darauf aufmerksam machen, daß im Inneren des Gehäuses dieses Produktes gefährliche Spannungen, die nicht isoliert sind und die einen elektrischen Schock verursachen können, herrschen.

### Achtung

**Lesen der Anleitungen** • Bevor Sie das Gerät zum ersten Mal verwenden, sollten Sie alle Sicherheits- und Bedienungsanleitungen genau durchlesen und verstehen.

**Aufbewahren der Anleitungen** • Die Hinweise zur elektrischen Sicherheit des Produktes sollten Sie aufbewahren, damit Sie im Bedarfsfall darauf zurückgreifen können.

**Befolgen der Warnhinweise** • Befolgen Sie alle Warnhinweise und Anleitungen auf dem Gerät oder in der Benutzerdokumentation.

**Keine Zusatzgeräte** • Verwenden Sie keine Werkzeuge oder Zusatzgeräte, die nicht ausdrücklich vom Hersteller empfohlen wurden, da diese eine Gefahrenquelle darstellen können.

## Instrucciones de seguridad • Español



Este símbolo se utiliza para advertir al usuario sobre instrucciones importantes de operación y mantenimiento (o cambio de partes) que se desean destacar en el contenido de la documentación suministrada con los equipos.



Este símbolo se utiliza para advertir al usuario sobre la presencia de elementos con voltaje peligroso sin protección aislante, que puedan encontrarse dentro de la caja o alojamiento del producto, y que puedan representar riesgo de electrocución.

### Precaución

**Leer las instrucciones** • Leer y analizar todas las instrucciones de operación y seguridad, antes de usar el equipo.

**Conservar las instrucciones** • Conservar las instrucciones de seguridad para futura consulta.

**Obedecer las advertencias** • Todas las advertencias e instrucciones marcadas en el equipo o en la documentación del usuario, deben ser obedecidas.

**Evitar el uso de accesorios** • No usar herramientas o accesorios que no sean específicamente recomendados por el fabricante, ya que podrían implicar riesgos.

### Warning

**Power sources** • This equipment should be operated only from the power source indicated on the product. This equipment is intended to be used with a main power system with a grounded (neutral) conductor. The third (grounding) pin is a safety feature, do not attempt to bypass or disable it.

**Power disconnection** • To remove power from the equipment safely, remove all power cords from the rear of the equipment, or the desktop power module (if detachable), or from the power source receptacle (wall plug).

**Power cord protection** • Power cords should be routed so that they are not likely to be stepped on or pinched by items placed upon or against them.

**Servicing** • Refer all servicing to qualified service personnel. There are no user-serviceable parts inside. To prevent the risk of shock, do not attempt to service this equipment yourself because opening or removing covers may expose you to dangerous voltage or other hazards.

**Slots and openings** • If the equipment has slots or holes in the enclosure, these are provided to prevent overheating of sensitive components inside. These openings must never be blocked by other objects.

**Lithium battery** • There is a danger of explosion if battery is incorrectly replaced. Replace it only with the same or equivalent type recommended by the manufacturer. Dispose of used batteries according to the manufacturer's instructions.

### Avertissement

**Alimentations** • Ne faire fonctionner ce matériel qu'avec la source d'alimentation indiquée sur l'appareil. Ce matériel doit être utilisé avec une alimentation principale comportant un fil de terre (neutre). Le troisième contact (de mise à la terre) constitue un dispositif de sécurité : n'essayez pas de le contourner ni de le désactiver.

**Déconnexion de l'alimentation** • Pour mettre le matériel hors tension sans danger, déconnectez tous les cordons d'alimentation de l'arrière de l'appareil ou du module d'alimentation de bureau (s'il est amovible) ou encore de la prise secteur.

**Protection du cordon d'alimentation** • Acheminer les cordons d'alimentation de manière à ce que personne ne risque de marcher dessus et à ce qu'ils ne soient pas écrasés ou pincés par des objets.

**Réparation-maintenance** • Faire exécuter toutes les interventions de réparation-maintenance par un technicien qualifié. Aucun des éléments internes ne peut être réparé par l'utilisateur. Afin d'éviter tout danger d'électrocution, l'utilisateur ne doit pas essayer de procéder lui-même à ces opérations car l'ouverture ou le retrait des couvercles risquent de l'exposer à de hautes tensions et autres dangers.

**Fentes et orifices** • Si le boîtier de l'appareil comporte des fentes ou des orifices, ceux-ci servent à empêcher les composants internes sensibles de surchauffer. Ces ouvertures ne doivent jamais être bloquées par des objets.

**Lithium Batterie** • Il a danger d'explosion s'il y a remplacement incorrect de la batterie. Remplacer uniquement avec une batterie du même type ou d'un type équivalent recommandée par le constructeur. Mettre au rebut les batteries usagées conformément aux instructions du fabricant.

### Vorsicht

**Stromquellen** • Dieses Gerät sollte nur über die auf dem Produkt angegebene Stromquelle betrieben werden. Dieses Gerät wurde für eine Verwendung mit einer Hauptstromleitung mit einem geerdeten (neutralen) Leiter konzipiert. Der dritte Kontakt ist für einen Erdschluß, und stellt eine Sicherheitsfunktion dar. Diese sollte nicht umgangen oder außer Betrieb gesetzt werden.

**Stromunterbrechung** • Um das Gerät auf sichere Weise vom Netz zu trennen, sollten Sie alle Netzkabel aus der Rückseite des Gerätes, aus der externen Stromversorgung (falls dies möglich ist) oder aus der Wandsteckdose ziehen.

**Schutz des Netzkabels** • Netzkabel sollten stets so verlegt werden, daß sie nicht im Weg liegen und niemand darauf treten kann oder Objekte darauf- oder unmittelbar dagegen gestellt werden können.

**Wartung** • Alle Wartungsmaßnahmen sollten nur von qualifiziertem Servicepersonal durchgeführt werden. Die internen Komponenten des Gerätes sind wartungsfrei. Zur Vermeidung eines elektrischen Schocks versuchen Sie in keinem Fall, dieses Gerät selbst öffnen, da beim Entfernen der Abdeckungen die Gefahr eines elektrischen Schlags und/oder andere Gefahren bestehen.

**Schlitze und Öffnungen** • Wenn das Gerät Schlitze oder Löcher im Gehäuse aufweist, dienen diese zur Vermeidung einer Überhitzung der empfindlichen Teile im Inneren. Diese Öffnungen dürfen niemals von anderen Objekten blockiert werden.

**Lithium-Batterie** • Explosionsgefahr, falls die Batterie nicht richtig ersetzt wird. Ersetzen Sie verbrauchte Batterien nur durch den gleichen oder einen vergleichbaren Batterietyp, der auch vom Hersteller empfohlen wird. Entsorgen Sie verbrauchte Batterien bitte gemäß den Herstelleranweisungen.

### Advertencia

**Alimentación eléctrica** • Este equipo debe conectarse únicamente a la fuente/tipo de alimentación eléctrica indicada en el mismo. La alimentación eléctrica de este equipo debe provenir de un sistema de distribución general con conductor neutro a tierra. La tercera pata (puesta a tierra) es una medida de seguridad, no puentearla ni eliminarla.

**Desconexión de alimentación eléctrica** • Para desconectar con seguridad la acometida de alimentación eléctrica al equipo, desenchufar todos los cables de alimentación en el panel trasero del equipo, o desenchufar el módulo de alimentación (si fuera independiente), o desenchufar el cable del receptáculo de la pared.

**Protección del cables de alimentación** • Los cables de alimentación eléctrica se deben instalar en lugares donde no sean pisados ni apretados por objetos que se puedan apoyar sobre ellos.

**Reparaciones/mantenimiento** • Solicitar siempre los servicios técnicos de personal calificado. En el interior no hay partes a las que el usuario deba acceder. Para evitar riesgo de electrocución, no intentar personalmente la reparación/mantenimiento de este equipo, ya que al abrir o extraer las tapas puede quedar expuesto a voltajes peligrosos u otros riesgos.

**Ranuras y aberturas** • Si el equipo posee ranuras o orificios en su caja/alojamiento, es para evitar el sobrecalentamiento de componentes internos sensibles. Estas aberturas nunca se deben obstruir con otros objetos.

**Batería de litio** • Existe riesgo de explosión si esta batería se coloca en la posición incorrecta. Cambiar esta batería únicamente con el mismo tipo (o su equivalente) recomendado por el fabricante. Desachar las baterías usadas siguiendo las instrucciones del fabricante.

# Quick Start — CrossPoint Plus Matrix Switchers

## Installation

### Step 1

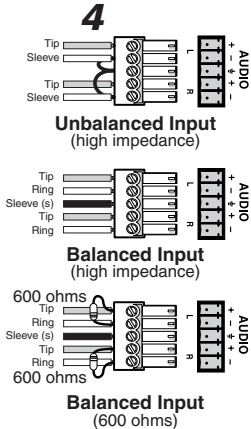
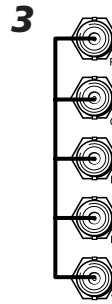
Mount the switcher in a rack.

### Step 2

Turn off power to the input and output devices, and remove the power cords from them.

### Step 3

Cable the switcher for RGBHV, RGBS, RGsB, RsGsBs, component video, S-video, or composite video input and output (3). See page 2-3 in this manual for details.

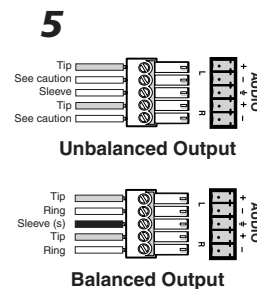


### Step 4

Cable the switcher for stereo audio input (HVA models). Each input has a 3.5 mm, 5-pole captive screw connector for balanced or unbalanced stereo audio input (4). Connectors are included with each switcher, but you must supply the audio cable. High impedance is generally over 800 ohms.

### Step 5

Cable the switcher for stereo audio output (HVA models). Each output has a 3.5 mm, 5-pole captive screw connector that outputs the selected unamplified, line level audio. Connect an audio device, such as an audio amplifier or powered speakers (5).



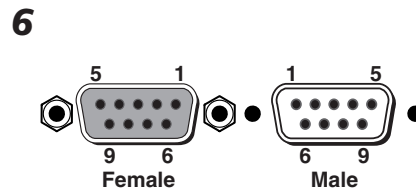
**CAUTION** Connect the sleeve to ground. Connecting the sleeve to a negative (-) terminal will damage the audio output circuits.

### Step 6

If desired, connect a control system or computer to the Remote RS-232/RS-422 port (6).

### Step 7

Plug the switcher, input devices, and output devices into a grounded AC source, and turn on the input and output devices.



Pin	RS-232	Function	RS-422	Function
1	—	Not used	TX-	Transmit data (-)
2	TX	Transmit data	TX+	Transmit data (+)
3	RX	Receive data	RX+	Receive data (+)
4	—	Not used	RX-	Receive data (-)
5	Gnd	Signal ground	Gnd	Signal ground
6	—	Not used	—	Not used
7	—	Not used	—	Not used
8	—	Not used	—	Not used
9	—	Not used	—	Not used

## Definitions

The following terms are used throughout this manual:

**Tie** — An input-to-output connection.

**Set of ties** — An input **typed** to two or more outputs. (An output can never be **typed** to multiple inputs.)

**Configuration** — One or more **ties** or **sets of ties**.

**Current configuration** — The currently active **configuration** (also called **configuration 0**).

**Preset** — A **configuration** that has been stored. One **preset** can be assigned to each input button. When a **preset** is retrieved from memory, it becomes the **current configuration**.

# Quick Start — CrossPoint Plus Matrix Switchers, cont'd

## Front Panel Controls

**Input and output buttons and LEDs** select and identify inputs and outputs. Input buttons also select presets. On HVA models, the output LEDs also display the audio level of the selected input.

**Enter button** saves changes when you change the configuration.

**Preset button** saves a configuration as a preset or recalls a previously-defined preset.

**View button** selects a view-only mode that prevents inadvertent configuration changes. On HVA models, the View button decrements the audio level of the selected input. The View LED indicates a negative (-) attenuation value.

**Esc button** cancels selections in progress and resets the front panel LEDs. The Esc button does **not** reset the current configuration, the RGBHV and Audio LEDs, any presets, or any audio gain/attenuation settings. On HVA models, the Esc button increments the audio level of the selected input. The Esc LED indicates a positive (+) gain value.

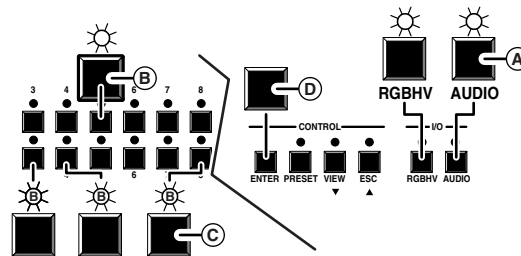
**RGBHV and Audio buttons** select/deselect video and/or audio. The Audio LED blinks to indicate audio breakaway. The Audio button also selects the audio level/adjust mode.

**Input and output label windows** hold labels that can be created easily with Extron's label software or with any Brother® P-Touch™ labeler.

LED key: ● = off, ☀ = on, ⚡ = blinking.

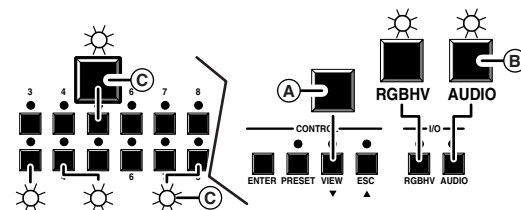
### Create a tie

- Press and release the RGBHV and/or Audio button(s) to select video and/or audio.
- Press and release the desired input button.
- Press and release the desired output button(s).
- Press and release the Enter button.



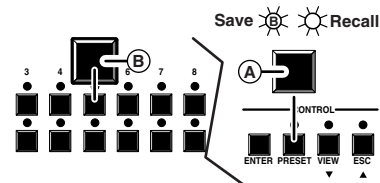
### View ties

- Press and release the View button.
- Press and release the RGBHV and/or Audio button(s) to select video and/or audio.
- Press and release the desired input button. The selected input and tied output LEDs light.



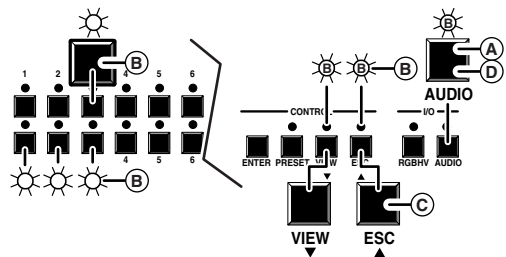
### Save or recall a preset

- To **save** a preset, press and **hold** the Preset button until the Preset LED begins to blink. To **recall** a preset, press and release the Preset button. The Preset LED turns on steadily.
- Press and release the input button associated with the desired preset number.



### View and adjust audio level

- Press and **hold** the Audio button until the Audio LED begins to blink.
- Press and release the desired input button. The level is displayed by the output LEDs, (+) by the Esc LED, and (-) by the View LED.
- Increment and decrement the level by pressing the Esc (▲) and View (▼) buttons.
- Press and release the Audio button to exit.



# Table of Contents

---

<b>Chapter 1 • Introduction</b> .....	1-1
<b>About the CrossPoint Plus Series Matrix Switchers</b> .....	1-2
<b>Features</b> .....	1-3
<b>Chapter 2 • Installation</b> .....	2-1
<b>Rack Mounting the Switcher</b> .....	2-2
<b>Cabling and Rear Panel Views</b> .....	2-2
Power connection .....	2-2
Video input and output connections .....	2-3
Audio input and output connections (HVA models only) .....	2-3
RS-232/422 connection .....	2-4
Additional rear panel views .....	2-5
<b>Chapter 3 • Operation</b> .....	3-1
<b>Front Panel Controls and Indicators</b> .....	3-2
Definitions .....	3-2
Input buttons, output buttons, and LEDs .....	3-3
Control buttons and LEDs .....	3-3
I/O controls .....	3-4
Front panel I/O label windows .....	3-4
<b>Front Panel Operations</b> .....	3-5
Power .....	3-5
I/O grouping .....	3-5
Creating a configuration .....	3-6
Example 1: Create a set of video and audio ties .....	3-7
Example 2: Add a tie to a set of video and audio ties .....	3-7
Example 3: Remove a tie from a set of video and audio ties .....	3-8
Viewing a configuration .....	3-9
Example 4: View video and audio, audio only, and video only ties .....	3-10
Muting and unmuting video and/or audio .....	3-11
Example 5: Muting and unmuting an output .....	3-12
Using presets .....	3-13
Example 6: Save a preset .....	3-14
Example 7: Recalle a preset .....	3-14
Viewing and adjusting the input audio level (HVA models only) .....	3-15
Example 8: View and adjust an audio level .....	3-15
Executive mode (front panel security lockout) .....	3-17
System reset to factory defaults .....	3-18
<b>Rear Panel Controls</b> .....	3-18
<b>Troubleshooting</b> .....	3-18
General checks .....	3-18
Plasma display S-video problem .....	3-19
<b>Worksheets</b> .....	3-19
Worksheet example 1: Entering system equipment .....	3-19



## Table of Contents, cont'd

---

Worksheet example 2: Drawing ties .....	3-19
Worksheet example 3: Test configuration .....	3-20
Matrix Switchers Configuration Worksheet .....	3-21
<b>Chapter 4 • Programmer's Guide</b> .....	4-1
<b>Host-to-Switcher Instructions</b> .....	4-2
<b>Switcher-Initiated Messages</b> .....	4-2
<b>Switcher Error Responses</b> .....	4-3
<b>Using the Command/Response Table</b> .....	4-3
<b>Command/Response Table</b> .....	4-4
<b>Chapter 5 • Matrix Software</b> .....	5-1
<b>Matrix Switchers Control Program</b> .....	5-2
Installing the software .....	5-2
Using the software .....	5-2
Overview .....	5-2
Windows buttons .....	5-3
Windows menus .....	5-4
Using emulation mode .....	5-5
Using the help system .....	5-5
<b>Button-Label Generator</b> .....	5-5
Using the software .....	5-6
<b>Appendix A • Specifications</b> .....	A-1
<b>Specifications</b> .....	A-2
<b>Part Numbers</b> .....	A-4
CrossPoint Plus part numbers .....	A-4
Optional accessories .....	A-4
Cables .....	A-5
<b>Appendix B • Reference Information</b> .....	B-1
<b>Hardware Upgrades</b> .....	B-2
Opening the switcher .....	B-2
Opening the CrossPoint Plus 84, 88, 124, and 128 .....	B-2
Opening the CrossPoint Plus 168 and 1616 .....	B-3
Closing the switcher .....	B-4
Swapping the serial ports .....	B-4
Installing a firmware update .....	B-5
Replacing the AC fuse (CrossPoint Plus 84, 88, 124, and 128 only) .....	B-6
<b>Button Labels</b> .....	B-6

All trademarks mentioned in this manual are the properties of their respective owners.

68-521-01 Rev. F  
11 04



# CrossPoint Plus Matrix Switchers

# Chapter One

## Introduction

About the CrossPoint Plus Matrix Switchers

Features

# Introduction

---

## About the CrossPoint Plus Series Matrix Switchers

The Extron CrossPoint Plus Series Matrix Switchers are ultra-wideband analog RGBHV matrix switchers that distribute any input to any combination of outputs. The matrix switchers can route multiple input/output configurations simultaneously. There are six series available that offer a variety of matrix sizes:

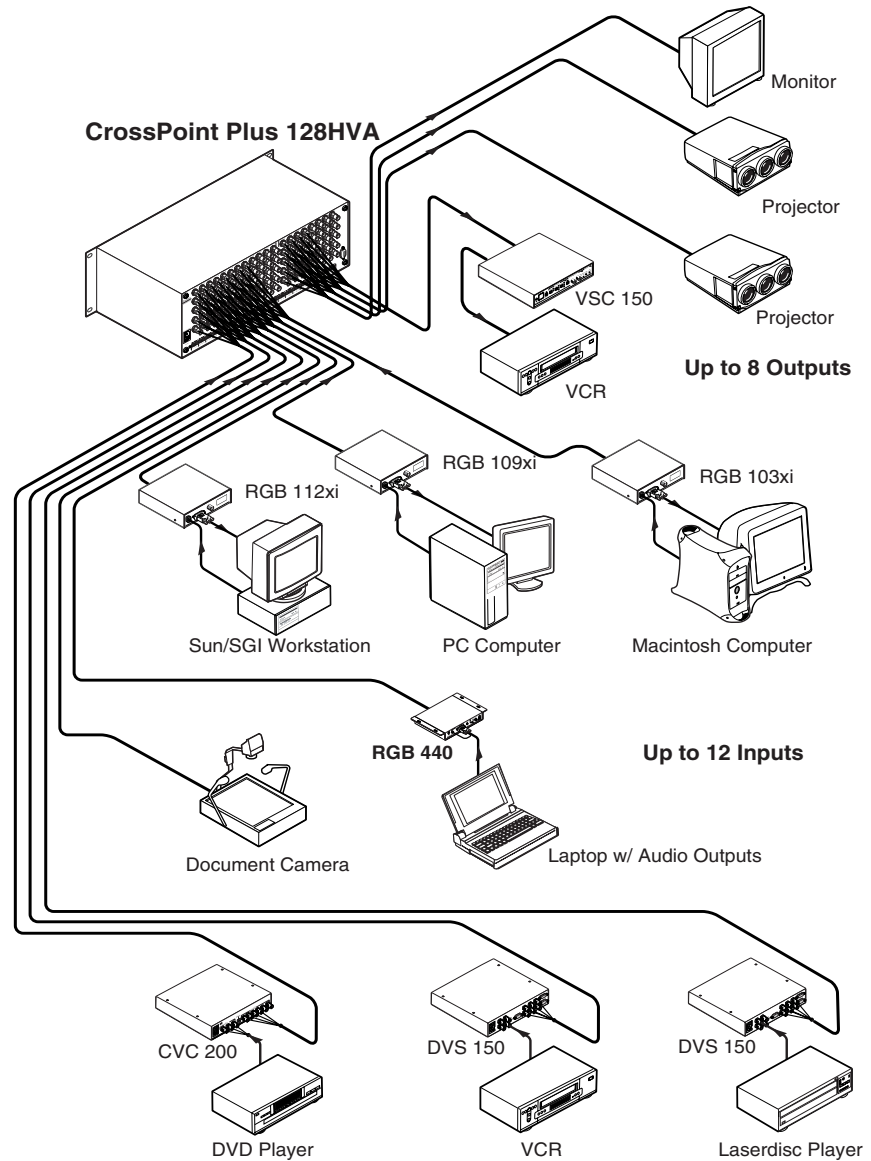
- CrossPoint Plus 84 (eight inputs by four outputs)
- CrossPoint Plus 88 (eight inputs by eight outputs)
- CrossPoint Plus 124 (twelve inputs by four outputs)
- CrossPoint Plus 128 (twelve inputs by eight outputs)
- CrossPoint Plus 168 (sixteen inputs by eight outputs)
- CrossPoint Plus 1616 (sixteen inputs by sixteen outputs)

Each series offers two models: HV for switching RGBHV signals, and HVA models for switching RGBHV and two-channel stereo audio (balanced and unbalanced). All models also switch RGBS, RGsB, RsGsBs, HDTV, component video, S-video, and composite video (figure 1-1). The audio switching can either be linked with the video (audio follow) or independent of the video (audio breakaway). Adjustable input audio gain and attenuation compensates for level differences between audio inputs.

The CrossPoint Plus Series are single box solutions to 425 MHz (-3dB) routing applications. Each input and output is individually isolated and buffered, and any input(s) can be switched to any one or all outputs with virtually no crosstalk or signal noise between channels.

The CrossPoint Plus 84, 88, 124, and 128 Matrix Switchers are housed in rack-mountable, 3U high, 19" wide metal enclosures. The CrossPoint Plus 168 and 1616 are in a 6U high enclosure. The appropriate rack mounting kit is included with each switcher. Each model has an internal 100VAC to 240VAC, 50/60 Hz, 30 watts (CrossPoint Plus 84, 88, 124, and 128) or 36 watts (CrossPoint Plus 168 and 1616), auto-switchable power supply that provides worldwide power compatibility.





**Figure 1-1 — A typical CrossPoint Plus matrix switcher application**

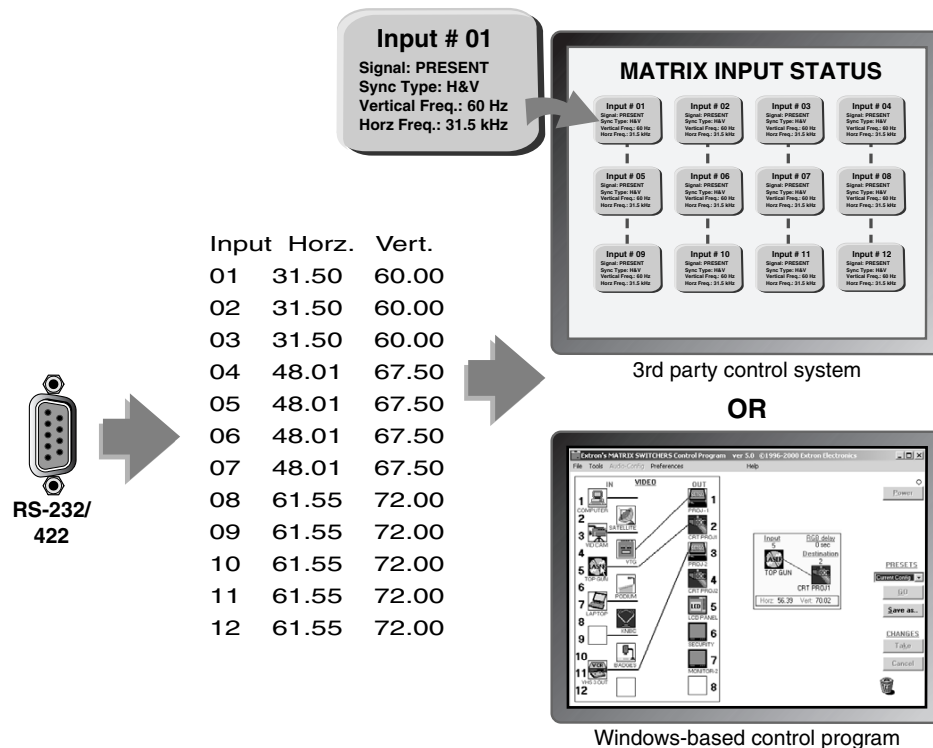
## Features

- Inputs** — These switchers offer 8, 12, or 16 RGBHV, RGBS, RGsB, RsGsBs, HDTV, component video, S-video, or composite video inputs on BNC connectors. Stereo audio can be balanced or unbalanced, on 3.5 mm, 5-pole captive screw terminals (HVA models).
- Outputs** — 4, 8, or 16 RGBHV, RGBS, RGsB, RsGsBs, HDTV, component video, S-video, or composite video outputs are available on BNC connectors. Stereo audio, balanced or unbalanced, on 3.5 mm, 5-pole captive screw terminals (HVA models).
- Bandwidth** — The CrossPoint Plus Series provides a minimum of 425 MHz (-3dB) video bandwidth, fully loaded. Designed for resolutions from 1280 x 1024 and up, the CrossPoint Plus Series maintains original signal integrity. When the best matrix for your particular application is required, the

# Introduction, cont'd

CrossPoint Plus Series delivers the highest performance and the most cost-effective solution.

**Digital Sync Validation Processing (DSVP™)** — In critical environments or unmanned, remote locations, it is vital to know that sources are active and switching. Extron's exclusive DSVP confirms that input sources are active by scanning all sync inputs for active signals. DSVP provides instantaneous frequency feedback for composite sync or separate horizontal and vertical sync signals via the switcher's RS-232/422 port. The frequency information can be displayed on any control system or in a Windows®-based control program on a local-area network (LAN) or internet (IP) connection (figure 1-2).



**Figure 1-2 — DSVP data display**

**Channel to channel isolation** — The CrossPoint Plus Series provides excellent isolation between channels and extremely low electromagnetic emissions—perfect for minimizing signal leakage in high security or government environments.

**I/O grouping** — Allows the matrix to be virtually divided into smaller sub-switchers, making installation and control easier. I/O grouping allows specific outputs, such as those designated for a specific video format, to be grouped together.

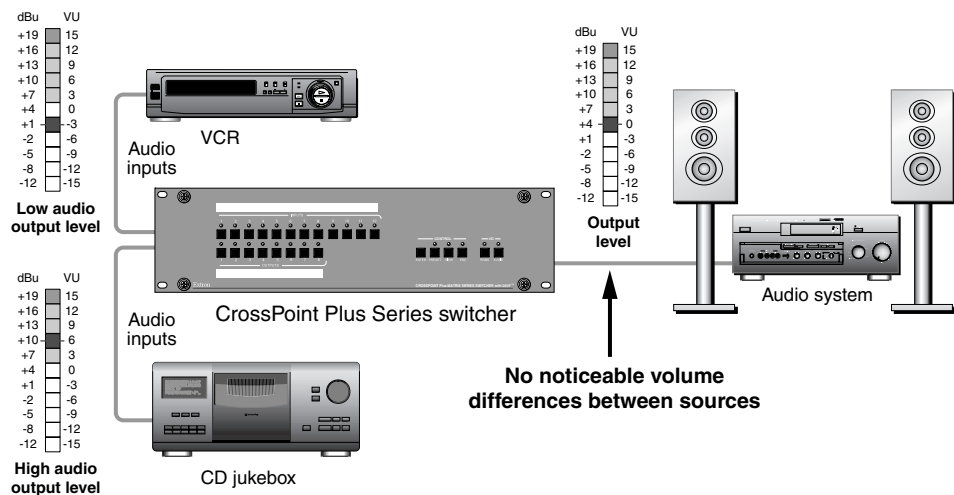
**Triple-Action Switching™ (RGB delay)** — RGB delay blanks the screen when the matrix switcher switches to a new source. The new sync signals precede the RGB signals, so there is no noise-filled scramble shown during the transition. The time delay between the RGB and sync signals is user adjustable up to five seconds under RS-232/422 control.

**View mode** — View mode allows the user to easily see which individual inputs and outputs are actively connected under front panel or RS-232/422 control.

**Operational flexibility** — Operations such as input/output selection, setting of presets, and adjustment of audio levels can be performed on the front panel or over the RS-232/RS-422 link. The RS-232/RS-422 link allows remote control via a PC, RS-232 capable PDA, or control system.

- **QuickSwitch Front Panel Controller (QS-FPC™)** — The CrossPoint Plus series QS-FPC feature supports touch-of-a-button input and output selection, preset creation and selection, and audio gain and attenuation control.
- **Windows-based control program** — Extron's Windows-based control program provides a versatile range of operational options with its graphical interface and drag-and-drop/point-and-click operation. The Windows-based control program also has an emulation mode that lets you create a switcher configuration file at the home office and then download it for use by the switcher on site.
- **Simple Instruction Set (SIS™)** — The remote control protocol uses Extron's SIS for easy programming and operation.

**Audio gain/attenuation** — Users can set the input level of audio gain or attenuation (-15dB to +9dB) via the RS-232/RS-422 link or from the front panel. Individual input audio levels can be adjusted so there are no noticeable volume differences between sources (figure 1-3).



**Figure 1-3 — Audio gain and attenuation**

**Global presets** — 16 memory presets are a time-saving feature that lets you set up and store input/output configurations in advance and then recall those configurations when needed with a few simple steps.

## Introduction, cont'd

---

**Switching flexibility** — Individually buffered, independent matrix switched video outputs with audio follow and audio breakaway for HVA versions.

- **Any input to any or all outputs**
- **Quick multiple tie** — Multiple inputs can be switched to multiple outputs simultaneously. This allows all displays (outputs) to change from source to source at the same time.
- **Audio follow** — Audio can be switched with the corresponding video input. This feature allows any audio signal to be selected with any video signal simultaneously to one or all outputs in any combination. Audio follow switching can be done via front panel control or under RS-232/RS-422 remote control.
- **Audio breakaway** — Audio can be broken away from its corresponding video signal. Audio breakaway switching can be done via front panel control or under RS-232/RS-422 control.

**Remote control** — The CrossPoint Plus switchers are remote controllable, using the MKP 1000 master control keypad and any combination of MCP 1000 slave control panels and/or MKP 1000 slave control keypads. The remote control devices are easy to use and provide tactile buttons for quick selection. Each MCP 1000 can be used for one-touch switching for a particular output and selecting global presets. Each MKP 1000 dedicated to an output can be used to select a different input for that output or to select a preset.

**Labeling** — Extron's label software ships with every Extron matrix switcher. You can create labels to place alongside the front panel input buttons and output buttons, with names, alphanumeric characters, or color bitmaps for easy and intuitive input and output selection. Alternatively, labels can be made with any Brother® P-Touch™ or comparable labeler.

**Executive mode (front panel security lockout)** — If a CrossPoint Plus Series Switcher is installed in an open area, where operation by unauthorized personnel may be a problem, a security lock-out feature can be implemented. When the front panel is locked, a special button combination is required to unlock the front panel controller before it can be operated.

**Rack mounting** — The switchers are mountable in any conventional 19" wide rack.

**Power** — The 100VAC to 240VAC, auto-switchable, internal power supply of the CrossPoint Plus Series provides worldwide power compatibility.



## CrossPoint Plus Matrix Switchers

# Chapter Two

## Installation

Rack Mounting the Switcher  
Cabling and Rear Panel Views

# Installation

## Rack Mounting the Switcher

The CrossPoint Plus 84, 88, 124, and 128 Matrix Switchers are housed in rack-mountable, 3U high, 19" wide metal enclosures. The CrossPoint Plus 168 and 1616 are in 6U high enclosures. The appropriate rack mount kit is included with each switcher. Rack mount the switcher as follows:

1. Insert the switcher into the rack, align the holes in the mounting bracket with those of the rack.
2. Secure the switcher to the rack using the supplied machine screws.

## Cabling and Rear Panel Views

All connectors are on the rear panel. Figure 2-1 shows the CrossPoint Plus 128HVA. The CrossPoint Plus 84, 88, and 124 are housed in the same 3U enclosure, but have fewer input and/or output connectors to accommodate the different matrix sizes each provides. Figure 2-2 shows the CrossPoint Plus 1616HVA. The CrossPoint Plus 168 is housed in the same 6U enclosure, but has fewer output connectors to accommodate its 16x8 matrix.

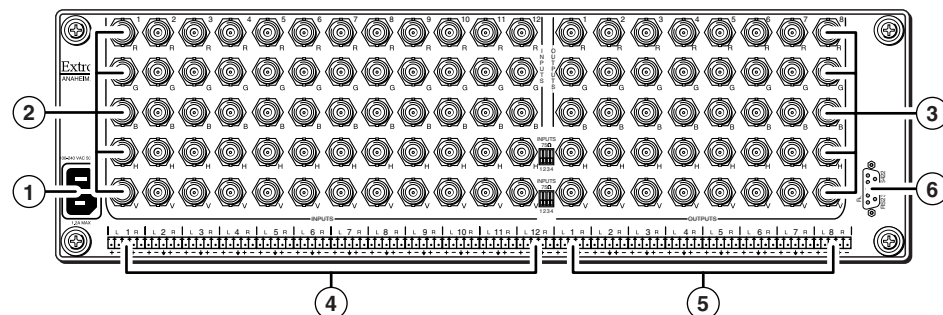


Figure 2-1 — Rear panel connectors, CrossPoint Plus 128HVA

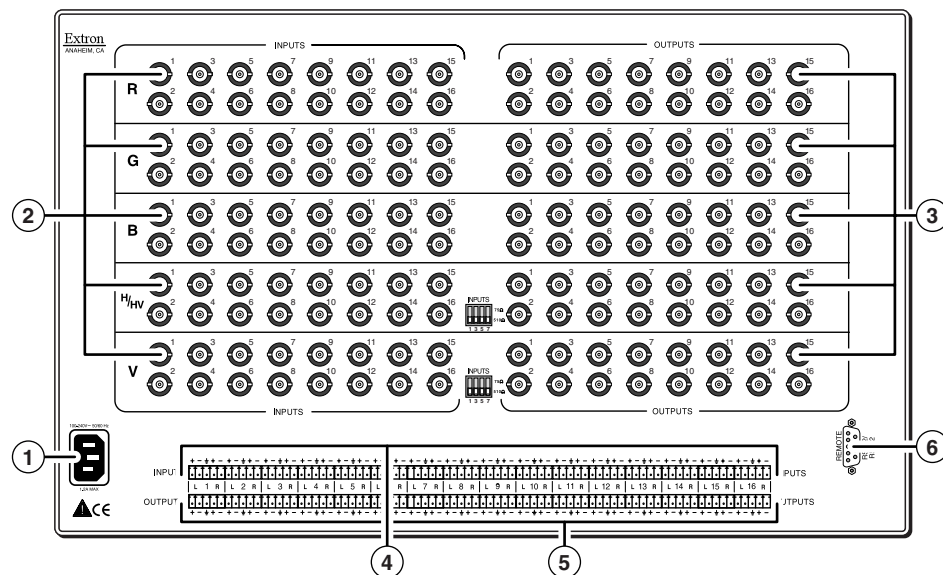


Figure 2-2 — Rear panel connectors, CrossPoint Plus 1616HVA

### Power connection

- 1 AC power connector — Plug a standard IEC power cord into this connector to connect the switcher to a 100 to 240VAC, 50 Hz or 60 Hz power source.

## Video input and output connections

**NOTE** All video input and output connections to the CrossPoint Plus switchers are made with female BNC connectors. Some types of video output devices do not have BNC video output connectors. For these cases, a suitable cable or connector adapter is necessary between the device output connector and the BNC input connector of the CrossPoint Plus.

- ② **RGBHV video inputs** — Connect RGBHV video inputs to these BNC connectors for each input.
- ③ **RGBHV video outputs** — Connect RGBHV video outputs to these BNC connectors for each output.

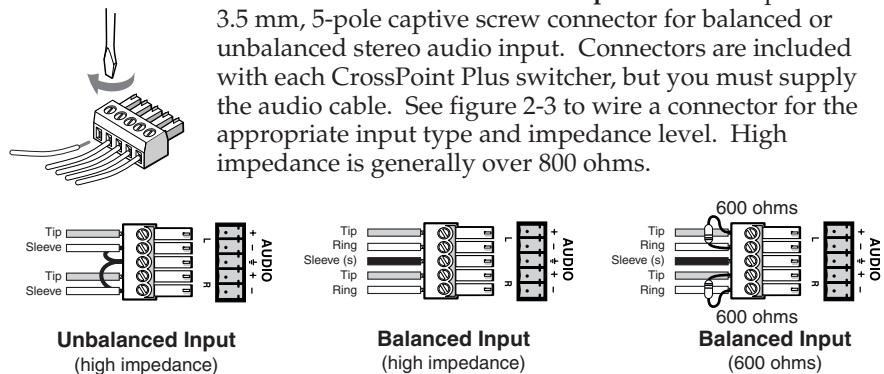
**NOTE** The CrossPoint Plus Series switchers can also switch RGBS, RGsB, RsGsBs, component video, S-video, or composite video by using four, three, two, or one BNC. If switching a video format other than RGBHV, ensure that the same video planes (R, G, B, H/HV, and/or V) are used on the switcher output as on the input.

**NOTE** The CrossPoint Plus Series Matrix Switchers do not alter the video signal in any way. The signal output by the switcher is in the same format as the input.

## Audio input and output connections (HVA models only)

**CAUTION** The captive screw connector can easily be inadvertently plugged partially into one receptacle and partially into an adjacent receptacle. This misconnection could damage the audio output circuits. Exercise care to ensure the captive screw connector is plugged into the desired input or output.

- ④ **Connections for balanced and unbalanced audio inputs** — Each input has a 3.5 mm, 5-pole captive screw connector for balanced or unbalanced stereo audio input. Connectors are included with each CrossPoint Plus switcher, but you must supply the audio cable. See figure 2-3 to wire a connector for the appropriate input type and impedance level. High impedance is generally over 800 ohms.



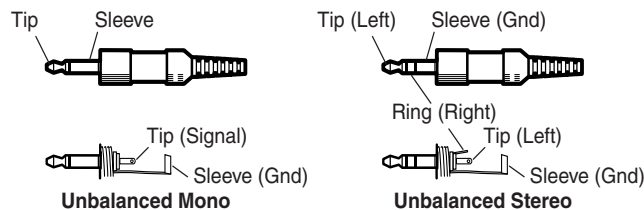
**Figure 2-3 — Captive screw connector wiring for inputs**

**NOTE** When making connections for the CrossPoint Plus Series Switcher from existing audio cables, see figure 2-4. A mono audio connector consists of the tip and sleeve. A stereo audio connector consists of the tip, ring and sleeve. The ring, tip, and sleeve wires are also shown on the captive screw audio connector diagrams, figure 2-3 and figure 2-5.

The audio level for each input can be individually set, via the front panel or RS-232/422, to ensure that the level on the output does not vary from input to input. See chapter 3, *Operation*, chapter 4, *Programmer's Guide*, and chapter 5, *Matrix Software*, for details.

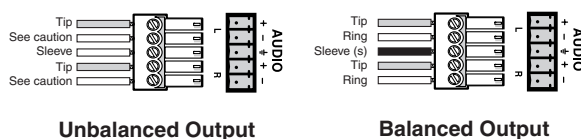


## Installation, cont'd



**Figure 2-4 — Phono audio connectors**

- ⑤ **Connections for audio outputs** — These 3.5 mm, 5-pole captive screw connectors output the selected unamplified, line level audio. Connect audio devices, such as an audio amplifier or powered speakers. See figure 2-5 to properly wire an output connector.



**Figure 2-5 — Captive screw connector wiring for audio output**

**CAUTION** Connect the sleeve to ground (Gnd). Connecting the sleeve to a negative (-) terminal will damage the audio output circuits.

By default, the audio output follows the video switch. Audio breakaway, commanded via the front panel, under RS-232/422 control, or Windows-based control program, allows you to select from any one of the audio input sources. See chapter 3, *Operation*, chapter 4, *Programmer's Guide*, and chapter 5, *Matrix Software* for details.

### RS-232/422 connection

- ⑥ **Remote/RS-232/RS-422 port** — Connect a host device, such as a computer or touch panel control, to the CrossPoint Plus via this 9-pin D connector for serial RS-232/RS-422 control (figure 2-6).

Pin	RS-232	Function	RS-422	Function
1	—	Not used	TX-	Transmit data (-)
2	TX	Transmit data	TX+	Transmit data (+)
3	RX	Receive data	RX+	Receive data (+)
4	—	Not used	RX-	Receive data (-)
5	Gnd	Signal ground	Gnd	Signal ground
6	—	Not used	—	Not used
7	—	Not used	—	Not used
8	—	Not used	—	Not used
9	—	Not used	—	Not used

**Figure 2-6 — RS-232/422 connector**

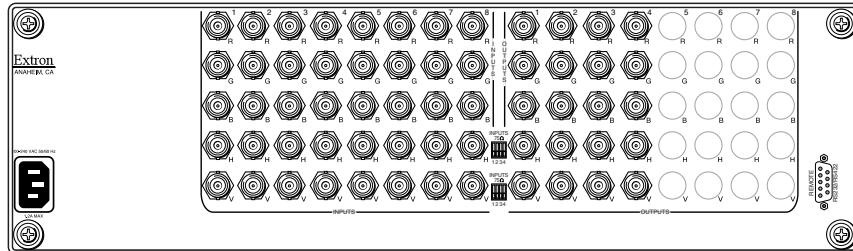
If desired, attach an MCP 1000 remote control panel master unit to the switcher's RS-232/RS-422 connector. You can also attach an MKP 1000 remote keypad or MCP 1000 slave unit to the MCP 1000 master unit. Refer to the *MCP 1000 Remote Control Panel User's Manual*, part # 68-456-01, and the *MKP 1000 User's Manual*, part # 68-355-01, for details.

See chapter 4, *Programmer's Guide*, for definitions of the SIS commands and chapter 5, *Matrix Software*, to install and use the control software.

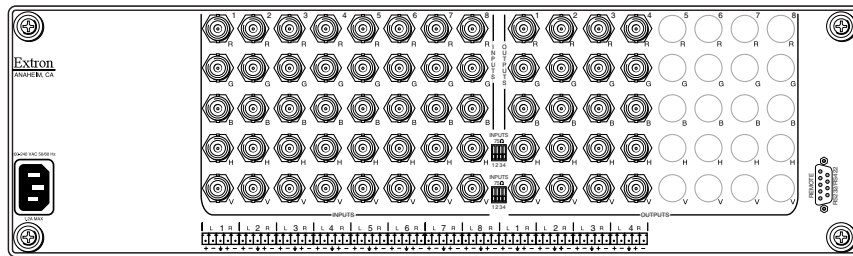
**NOTE** The CrossPoint Plus Series Matrix Switchers are factory configured for RS-232 control. To use the switcher under RS-422 control, an internal cable must be moved. See appendix B for the procedure for shifting the cable.

## Additional rear panel views

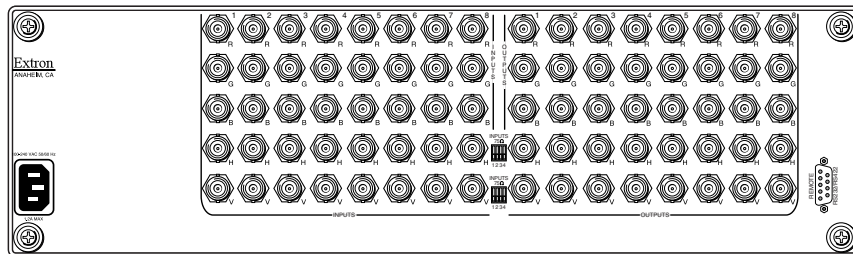
The following figures show the rear panels of all CrossPoint Plus switchers, except for the CrossPoint Plus 128HVA, which is shown in figure 2-1, and the CrossPoint Plus 1616HVA, which is shown in figure 2-2.



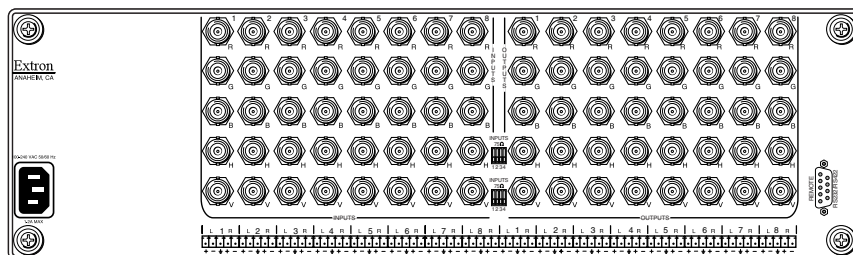
**Figure 2-7 — Rear panel view, CrossPoint Plus 84HV**



**Figure 2-8 — Rear panel view, CrossPoint Plus 84HVA**

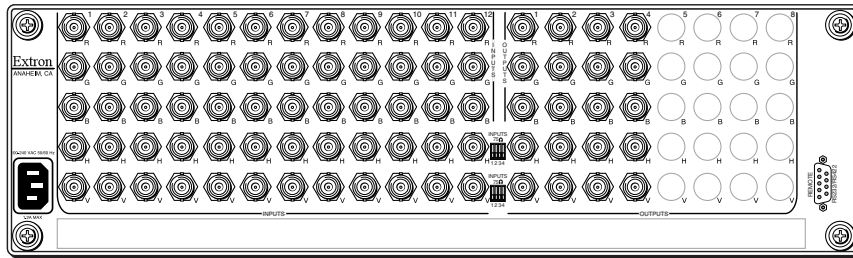


**Figure 2-9 — Rear panel view, CrossPoint Plus 88HV**

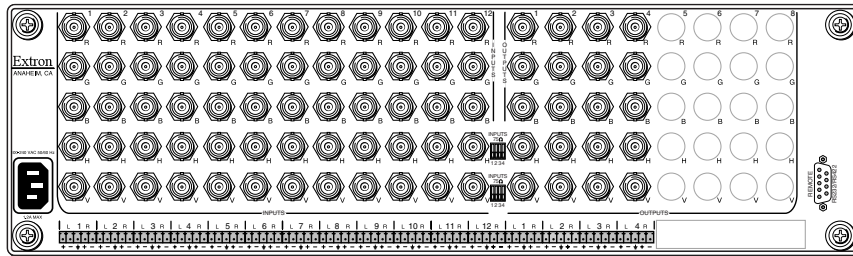


**Figure 2-10 — Rear panel view, CrossPoint Plus 88HVA**

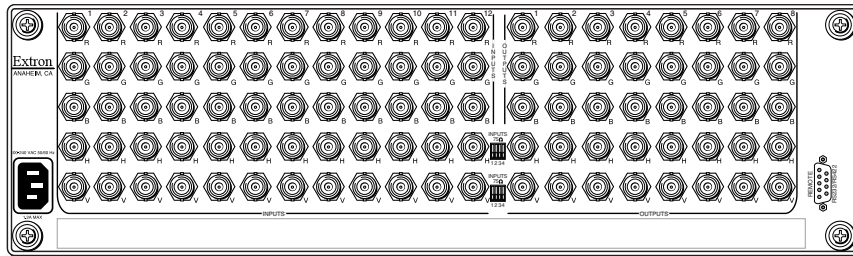
# Installation, cont'd



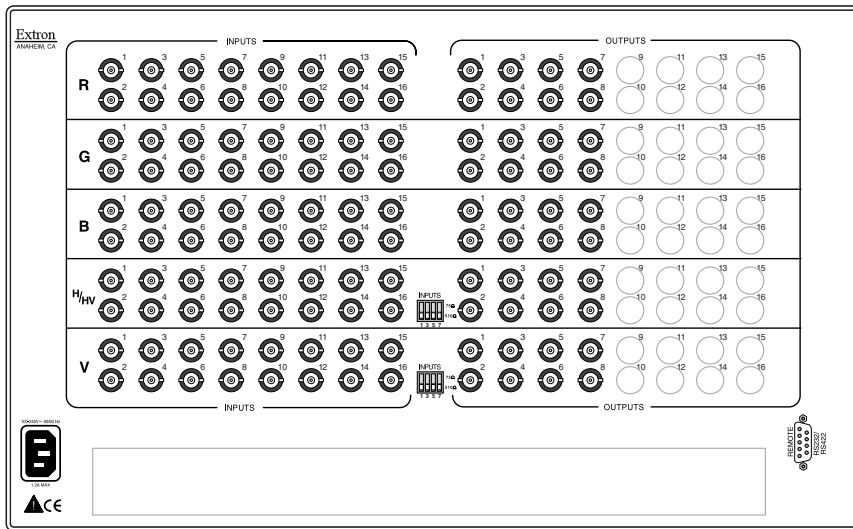
**Figure 2-11 — Rear panel view, CrossPoint Plus 124HV**



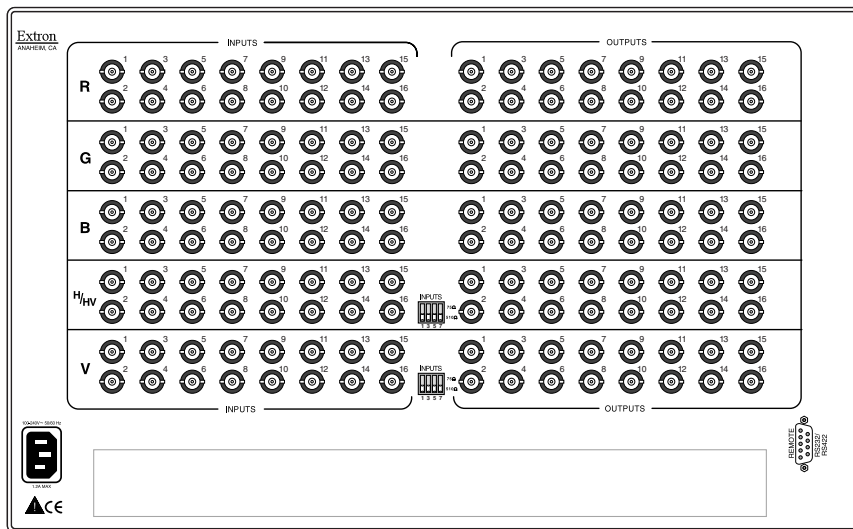
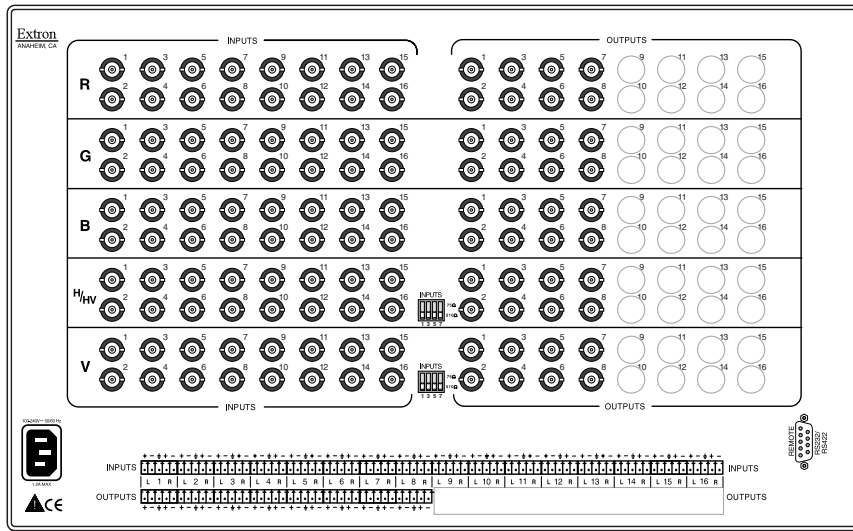
**Figure 2-12 — Rear panel view, CrossPoint Plus 124HVA**



**Figure 2-13 — Rear panel view, CrossPoint Plus 128HV**



**Figure 2-14 — Rear panel view, CrossPoint Plus 168HV**



# Installation, cont'd

---



## CrossPoint Plus Matrix Switchers

# 3

# Chapter Three

## Operation

Front Panel Controls and Indicators

Front Panel Operations

Rear Panel Controls

Worksheets

# Operation

## Front Panel Controls and Indicators

The front panel controls (figure 3-1 and figure 3-2) are grouped into two sets. The input and output buttons and LED indicators are grouped on the left side of the control panel. The control buttons and input/output (I/O) selection buttons and indicators are grouped on the right side of the panel.

**NOTE** While the number of inputs and outputs varies depending on the size of the matrix, there are only two front panel arrangements. The CrossPoint Plus 84, 88, 124, and 128 have 12 input buttons and 8 output buttons (figure 3-1). The CrossPoint Plus 168 and 1616 have 16 input buttons and 16 output buttons (figure 3-2).

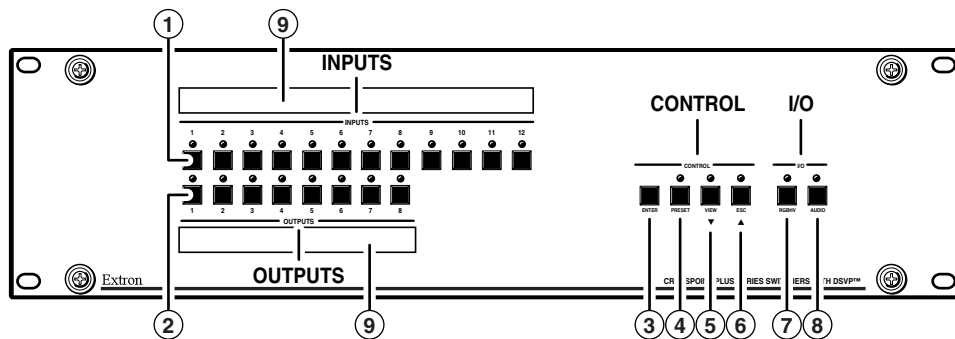


Figure 3-1 — Front panel, CrossPoint Plus 128 HVA

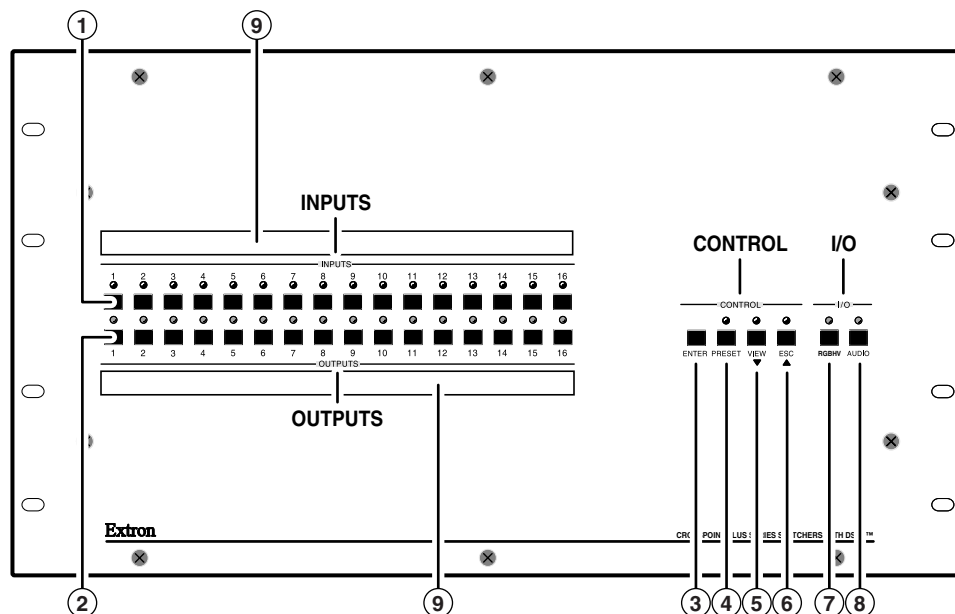


Figure 3-2 — Front Panel, CrossPoint Plus 1616 HVA

## Definitions

The following terms apply to Extron Matrix Switchers, and are used throughout this manual:

**Tie** — An input-to-output connection.

**Set of ties** — An input tied to two or more outputs. (An output can never be tied to more than one input.)

**Configuration** — May consist of one tie or one or more sets of ties.



---

**Current configuration** — The **configuration** that is currently being used (also called **configuration 0**).

**Global memory preset** — A **configuration** that has been stored. Up to 16 **global memory presets** can be stored in memory. The input buttons select the desired **preset** memory location to load or retrieve a **preset**. When a **preset** is retrieved from memory, it becomes the **current configuration**. One **preset** can be assigned to each input button. (On CrossPoint Plus 84, 88, 124, and 128 models, **presets** 13 through 16 can only be stored and retrieved via the RS-232/422 link.)

## Input buttons, output buttons, and LEDs

**NOTE** *If the switcher has fewer inputs and outputs than input and output buttons and LEDs, only the applicable buttons and LEDs perform the function of selecting and identifying an input or output.*

- ① **Input 1 through 12 (16) buttons and LEDs** — The input buttons have two independent functions: to select an input and to select a preset. The input LEDs identify selected inputs. A more detailed explanation of the two functions is included in *Front Panel Operations* beginning on page 3-5.
- ② **Output 1 through 8 (16) buttons and LEDs** — The output buttons and LEDs select and identify outputs. On HVA models, the output LEDs also display the user-adjustable audio level of the selected input. A more detailed explanation of the two functions is included in *Front Panel Operations* beginning on page 3-5.

## Control buttons and LEDs

- ③ **Enter button** — The Enter button saves changes when you set up a new configuration. To create a simple configuration, specify video, audio, or both (see controls ⑦) and ⑧); press the desired input button ①); press the desired output button(s) ②); and press the Enter button.
- ④ **Preset button and LED** — The Preset button saves a configuration as a preset or recalls and makes current a previously defined preset. The Preset LED indicates save mode when it is blinking and recall mode when it lights steadily.
- ⑤ **View button and LED** — The View button selects a view-only mode that allows the display of the current CrossPoint Plus configurations and provides a way to mute and unmute video and audio outputs. The view-only mode helps prevent changing configurations by accident. The View LED indicates that the CrossPoint Plus is in view-only mode.

In view-only mode, pressing any input button ①) or output ②) button lights the LEDs for the input and all outputs that are a part of that set of ties. Pressing the button for any unassigned output lights only the output LEDs for all of the unassigned outputs. No input LED is lit.

As a secondary function on HVA models, the View button decrements the audio level of the selected input. In audio adjustment mode, the View LED indicates a negative (-) attenuation value. A more detailed explanation of audio level adjustment is included in *Viewing and adjusting the input audio level (HVA models only)* on page 3-15.

- ⑥ **Esc button and LED** — The Esc button cancels operations or selections in progress and resets the front panel LEDs. The Esc button does **not** reset the current configuration, the RGBHV and Audio LEDs, any presets, or any audio gain/attenuation settings. The Esc LED flashes once after the Esc button is pressed and released to indicate the escape function.

## Operation, cont'd

As a secondary function on HVA models, the Esc button increments the audio level of the selected input. In audio adjust mode, the Esc LED indicates a positive (+) gain value. A more detailed explanation of audio level adjustment is included in *Viewing and adjusting the input audio level (HVA models only)* on page 3-15.

### I/O controls

When creating or viewing a configuration, you must specify whether the configuration applies to video, audio, or both. This is done with the RGBHV (7) and Audio (8) buttons.

**NOTE** Although present, the Audio button has no function on HV models.

- 7 **RGBHV button and LED** — The RGBHV button selects and deselects video for a configuration being created or viewed. The RGBHV LED lights to indicate that video is available for configuration or viewing.
- 8 **Audio button and LED** — The Audio button selects and deselects audio for a configuration that is being created or viewed. The Audio LED lights to indicate that the audio configuration follows the video configuration. The Audio LED blinks to indicate that the audio configuration is broken away from the video configuration.

As a secondary function, the Audio button selects the audio level display/adjust mode. Press and hold the Audio button until the Audio LED begins to blink. If the RGBHV LED was lit, it turns off. Select an input. The current audio level setting for the selected input is displayed in the output LEDs. The audio level for the selected input can be incremented and decremented by pressing the View (5) and Esc (6) buttons. A more detailed explanation of audio level adjustment is included in *Viewing and adjusting the input audio level (HVA models only)* on page 3-15.

### Front panel I/O label windows

- 9 **Input and output label panels** — These translucent panels can be removed and replaced to insert labels behind the panels. To remove a panel, insert the Phillips-head end of an Extron tweaker or small Phillips-head screwdriver into the hole in one end of the panel, and gently slide the tab on the edge of the panel out of the recess in the switcher housing.

Input and output labels can be created easily with Extron's button label generator software, which ships with every Extron Matrix Switcher, or with any Brother P-Touch labeler. Each input and output can be labeled with names, alphanumeric characters, or even color bitmaps for easy and intuitive input and output selection (figure 3-3). See chapter 5 for details on using the label software.

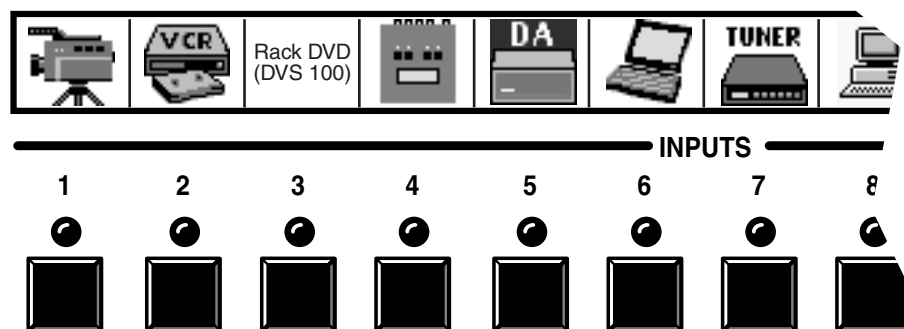


Figure 3-3 — Sample label

## Front Panel Operations

The following paragraphs detail the power-up process and then provide sample procedures for creating ties, sets of ties, and configurations; changing a configuration; viewing ties, sets of ties, and configurations; saving a preset; recalling a preset; and viewing and adjusting the audio level.

### Power

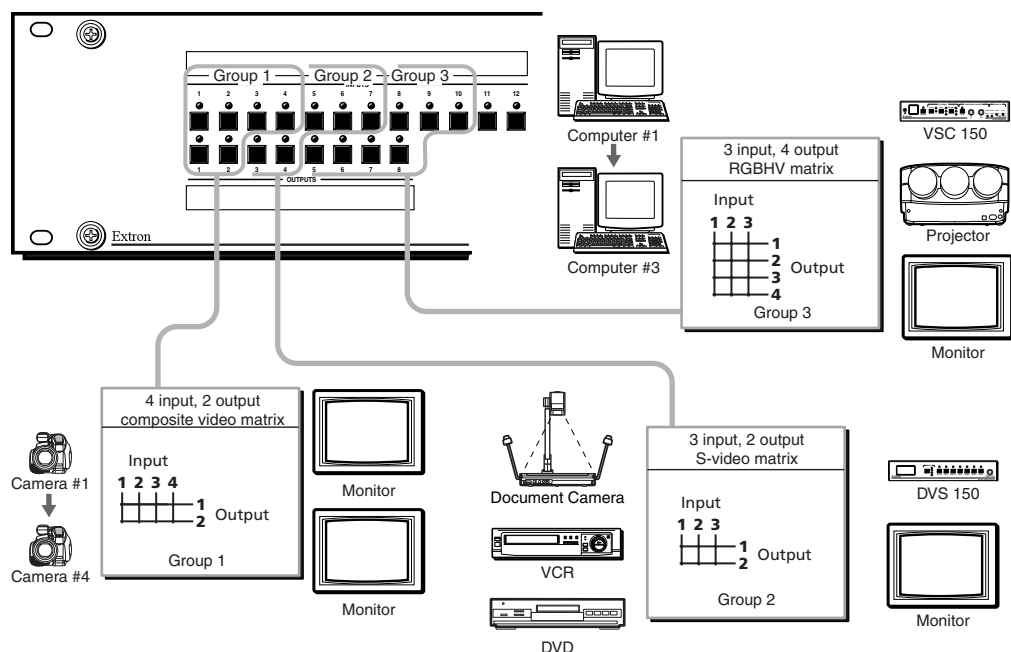
On all models, power is automatically applied when the power cord is connected to an AC source. When AC power is applied, the switcher performs a self-test that blinks the front panel LEDs during the test. An error-free power up self-test sequence leaves the RGBHV and/or the Audio LED(s) on, depending on the model, and all other LEDs off.

The current configuration and all presets are saved in non-volatile memory. When power is applied, the last current configuration is retrieved. The previous presets remain intact.

If an error occurs during the self-test, the switcher locks up and will not operate. If your switcher locks up on power-up, call the Extron S<sup>3</sup> Sales & Technical Support Hotline.

### I/O grouping

I/O grouping is an RS-232/422 controlled feature that allows you to subdivide the front panel control of the matrix into four smaller functional subswitchers. Inputs and outputs can be assigned to one of four groups or not assigned to any group (figure 3-4). Once assigned to a group, inputs and outputs can only be tied within that group from the front panel. For example, a front panel operator cannot tie an input that is assigned to group 1 to an output that is assigned to group 2. Ungrouped inputs and outputs can be switched to outputs and inputs in any group.



**Figure 3-4 — I/O grouping of incompatible video formats**

## Operation, cont'd

---

The I/O groups can be set up only by using the RS-232/422 port and either the SIS or the Windows control program. Ties between groups (an input in group 1 tied to an output in group 2) can be created under RS-232/422 control. Presets can also be created under RS-232/422 control that tie inputs and outputs across group boundaries. These presets are selectable from the front panel.

Suggested applications for the I/O grouping feature include:

- Segregating specific video formats to prevent an input in one video format from being inadvertently applied to an output device that supports another video format.
- Segregating input and output devices that are in separate rooms.
- Isolating video from being displayed on specific output devices for operational security reasons.

The I/O groups created under RS-232/422 control can result in front panel indications that are different from indications when grouping is not used. In the following paragraphs, the effects of I/O grouping on the front panel indications are included.

### Creating a configuration

The current configuration can be changed using the front panel buttons. To change the current configuration, do the following:

1. Press the Esc button to clear any input LEDs, output LEDs, or control LEDs that may be on.
2. Select to configure video, audio, or both by pressing the RGBHV and/or Audio buttons.
3. Select the desired input and output(s) by pressing the input and output buttons.
4. Press and release the Enter button.
5. Repeat steps 1 through 4 to create additional ties until the desired configuration is complete.

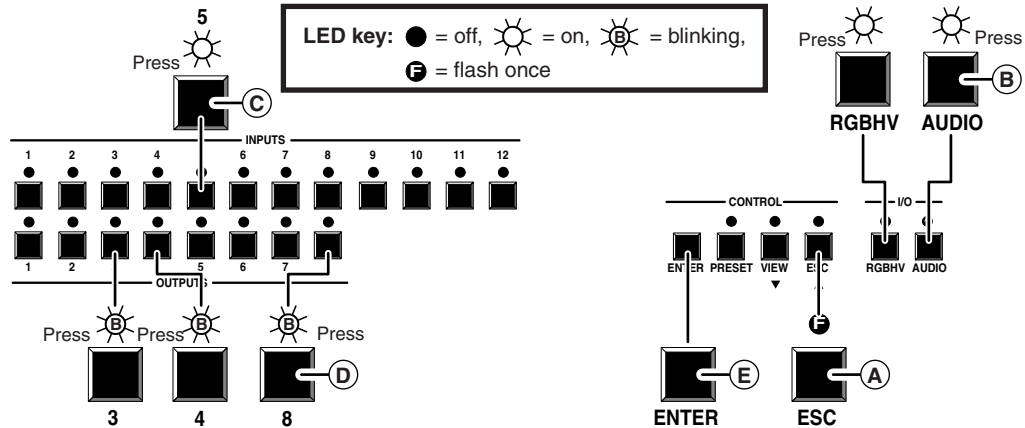
- NOTE**
1. Only one video input and one audio input can be tied to an output.
  2. If a tie is made between an input and an output, and the selected output was previously tied to another input, the older tie is broken in favor of the newer tie.
  3. To indicate current ties, output LEDs light when an input is selected. To clear unwanted outputs press and release the associated output buttons.
  4. If, when configuring video and audio ties, the Audio LED blinks and the RGBHV LED is on after selecting an input or output, the LEDs indicate audio breakaway, meaning that the audio ties are not the same as the video ties for that input.
  5. If an input with no tie is selected, only that input's LED lights.
  6. When the RGBHV and Audio LEDs are on, if an input with an audio tie but no video tie is selected, the input's LED lights and the Audio LED blinks.
  7. As each output is selected, the associated output LED blinks to indicate a tentative tie. LEDs for output(s) that were already tied to the input light steadily. Outputs that are already tied can be left on, along with new blinking selections, or toggled off by pressing the associated output button.

8. If the input button for a grouped input is pressed, and then the output button for an output in a different group is pressed, the associated output LED blinks twice and goes out to indicate that output cannot be tied to the input. The associated input LED remains lit.

### Example 1: Create a set of video and audio ties

See Figure 3-5 and the following steps for an example in which input 5 is tied to outputs 3, 4, and 8.

**NOTE** This example assumes that there are no ties in the current configuration.



**Figure 3-5 — Example 1: Creating a tie**

- (A) Press and release the Esc button. The Esc LED flashes once.
- (B) If necessary to select video and audio for the tie, press and release the RGBHV and Audio buttons until the RGBHV and Audio LEDs light.
- (C) Press and release the input 5 button. The input 5 LED lights.
- (D) Press and release the output 3, output 4, and output 8 buttons. The output 3, output 4, and output 8 LEDs blink to indicate a tentative tie.

**NOTE** The entire set of ties can be aborted at this point by pressing and releasing the Esc button. The Esc LED flashes once.

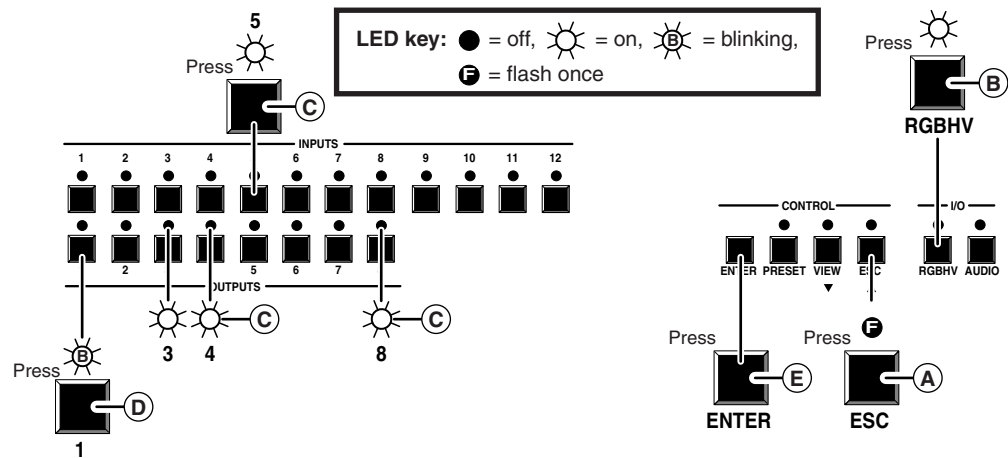
- (E) Press and release the Enter button. The input and output LEDs turn off. The current configuration is now defined as video and audio input 5 tied to video and audio output 3, output 4, and output 8.

### Example 2: Add a tie to a set of video and audio ties

See figure 3-6 and the following steps for an example in which a new video tie is added to the current configuration.

- (A) Press and release the Esc button. The Esc LED flashes once.
- (B) If it is necessary to select video-only for the tie, press and release the RGBHV and Audio buttons until the RGBHV LED lights and the Audio LED is off.
- (C) Press and release the input 5 button. The input 5 LED lights. If the steps in Example 1 have been completed, the output 3, output 4, and output 8 LEDs light to indicate ties created in Example 1.
- (D) Press and release the output 1 button. The output 1 LED blinks to indicate a tentative tie.

## Operation, cont'd

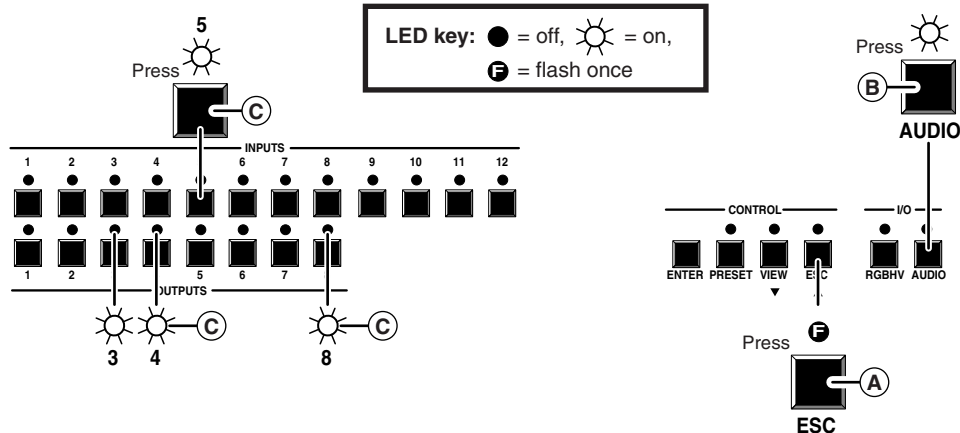


**Figure 3-6 — Example 2: Adding a video tie**

- (E) Press and release the Enter button. The input and output LEDs turn off. The current configuration is now defined as video input 5 tied to video output 1, output 3, output 4, and output 8; and audio input 5 tied to audio output 3, output 4, and output 8.

### Example 3: Remove a tie from a set of video and audio ties

See figure 3-7 and the following steps for an example in which an existing audio tie is removed from the current configuration.

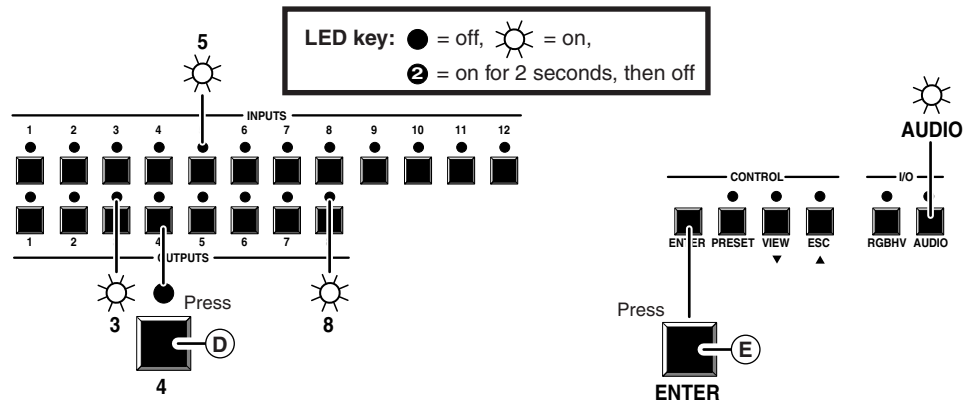


**Figure 3-7 — Example 3: Selecting audio, selecting input 5**

- (A) Press and release the Esc button. The Esc LED flashes once.
- (B) If necessary to select audio-only for the tie, press and release the RGBHV and Audio buttons until the RGBHV LED is off and the Audio LED lights.
- (C) Press and release the input 5 button. The input 5 LED lights. If the steps in Example 1 have been completed, the output 3, output 4, and output 8 LEDs light to indicate ties created in Example 1.

**NOTE** The output 1 LED does not light even if the steps in Example 2 were completed because Example 2 added a video tie only.

- (D) Press and release the output 4 button (figure 3-8). The output 4 LED turns off, while the output 3 and output 8 LEDs remain lit.



**Figure 3-8 — Example 3, step d: Removing an audio tie**

- (E) Press and release the Enter button. The input and output LEDs turn off. The current configuration is now defined as video input 5 tied to video output 1, output 3, output 4, and output 8; and audio input 5 tied to audio output 3 and output 8.

## Viewing a configuration

The current configuration can be viewed using the front panel buttons. The view-only mode prevents inadvertent changes to the current configuration. View-only mode also provides a way to mute video and audio outputs (see *Muting and unmuting video and/or audio* in this chapter).

To view the current configuration, do the following:

1. Press the Esc button to clear any input LEDs, output LEDs, or control LEDs that may be on.
2. Press and release the View button.
3. Select video, audio, or both to view by pressing the RGBHV and Audio buttons.
4. Select the desired input or output(s) for which ties need to be viewed by pressing the input and output buttons.

- NOTE**
1. To see all ties of the current configuration, press and release each input and output button, one at a time, with the RGBHV and Audio LEDs on.
  2. If you select a grouped input or output in view-only mode, all of the input and output LEDs in the group flash for half a second and then the current configuration is displayed in the normal manner.
  3. In view-only mode, you can view video and audio, video-only, or audio-only ties. Pressing and releasing the RGBHV and Audio buttons toggles each on and off.
  4. If, when you view video and audio ties, the Audio LED blinks and the RGBHV LED is on after selecting an input or output, the LEDs indicate that the audio ties are not the same as the video ties for that input (audio breakaway is active). Toggle the RGBHV LED off by pressing and releasing the RGBHV button.
  5. When you enter view-only mode, the output LEDs turn on for all outputs without ties. Likewise, when an output button is pushed for which there are no ties, the output LEDs turn on for all outputs without ties. The blinking Audio LED indicates audio breakaway for one or more of those outputs.

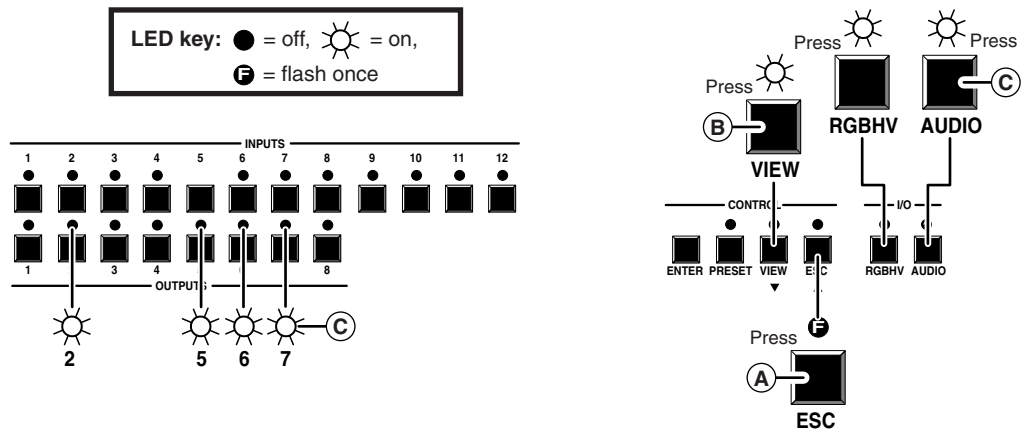


## Operation, cont'd

### Example 4: View video and audio, audio-only, and video-only ties

See figure 3-9, figure 3-10, figure 3-11, and figure 3-12 and the following steps for an example of viewing the video and audio, audio-only, and video-only ties in the current configuration.

**NOTE** Example 4 shows the process of viewing the current configuration after the steps in Examples 1, 2, and 3 have been performed.

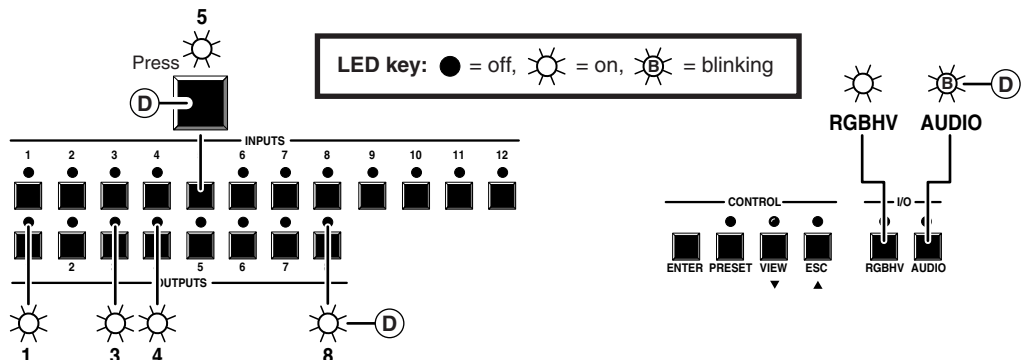


**Figure 3-9 — Example 4: Viewing the current configuration, no input selected**

- (A) Press and release the Esc button. The Esc LED flashes once.
- (B) Press and release the View button to enter view-only mode. The View LED lights. With no input LED selected, all output LEDs that have no established ties light.
- (C) To select both video and audio for viewing, if necessary, press and release the RGBHV and Audio buttons until the RGBHV LED and Audio LED light. With no input LED selected, all output LEDs that have no established ties light.
- (D) Press and release the input 5 button (figure 3-10). The input 5 LED lights.

If ties are established for input 5, all output LEDs toggle; outputs with no ties turn off and the LEDs associated with all outputs tied to input 5 (audio, video, or audio and video ties) light. If no ties are established for input 5, all output LEDs turn off.

If audio is broken away, the Audio LED blinks.

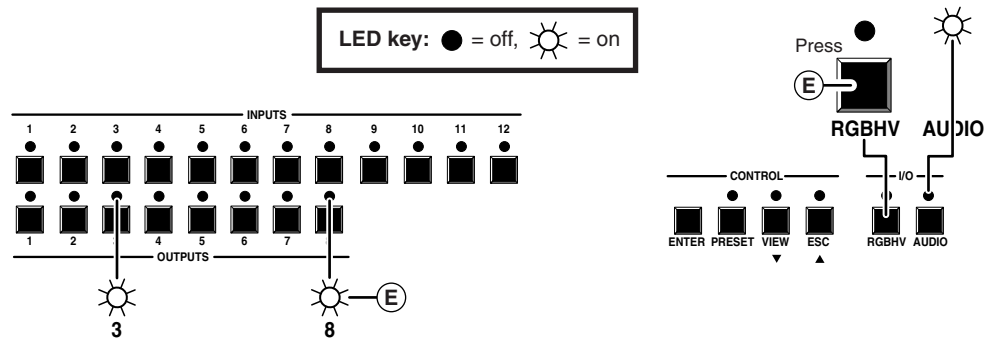


**Figure 3-10 — Example 4, step d: Viewing the current configuration, video and audio**

**NOTE** A set of ties can also be viewed by selecting a tied output. To demonstrate this, note the number of a lit output LED and press and release the output button for an unlit (untied) output LED. Observe that all of the untied outputs light. Then press the output button for the output LED noted previously and observe that the selected output LED, the tied input LED (input 5), and the output LEDs for all of the outputs that are tied to the input.

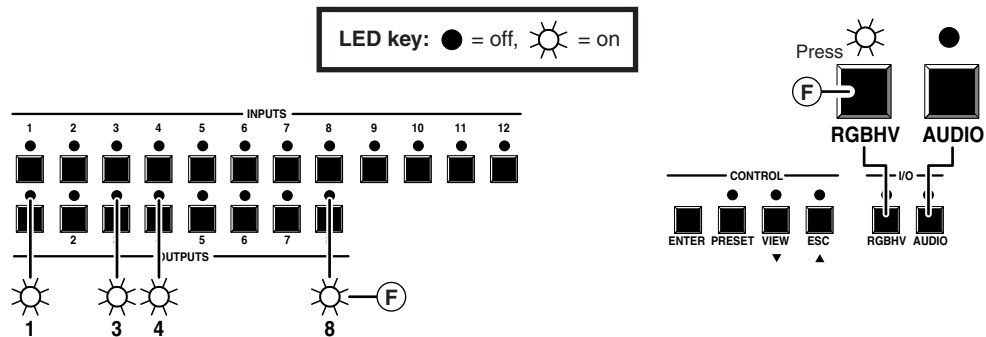
- (E) Press and release the RGBHV button to toggle the Video LED off (figure 3-11). If audio is broken away, the Audio LED stops blinking and lights steadily.

If audio ties are established for input 5, the output LEDs for all audio outputs tied to input 5 light. If no ties are established for input 5, all output LEDs turn off.



**Figure 3-11 — Example 4, step e: Viewing the current configuration, audio-only**

- (F) Press and release the RGBHV and Audio buttons to toggle the Video LED on and the Audio LED off (figure 3-12).



**Figure 3-12 — Example 4, step f: Viewing the current configuration, video-only**

If video ties are established for input 5, the output LEDs for all video outputs tied to input 5 light. If no ties are established for input 5, all output LEDs turn off.

## Muting and unmuting video and/or audio

Individual outputs can be muted or unmuted by doing the following:

1. Press the Esc button to clear any input LEDs, output LEDs, or control LEDs that may be on.
2. Press and release the View button.
3. Select video, audio, or both to mute or unmute by pressing the RGBHV and/or Audio buttons.

## Operation, cont'd

---

4. One at a time, press and **hold** the output button(s) for the desired output(s) for approximately 2 seconds. The output LED(s) for the selected output(s) blink to indicate the mute or return to their previous state to indicate the unmute.
5. Press and release the View button to return to normal switcher operation.

- NOTE**
1. You can mute video and audio, video-only, or audio-only outputs. Pressing and releasing the RGBHV and Audio buttons toggles each selection on and off.
  2. When you enter view-only mode, the output LEDs turn **on** for all outputs **without** ties.
  3. The video mute function mutes the R, G, and B planes only; the H and V planes are still active.
  4. Mutes are **not** saved to non-volatile memory. When power is removed and restored, the mute settings are lost.

### Example 5: Muting and unmuting an output

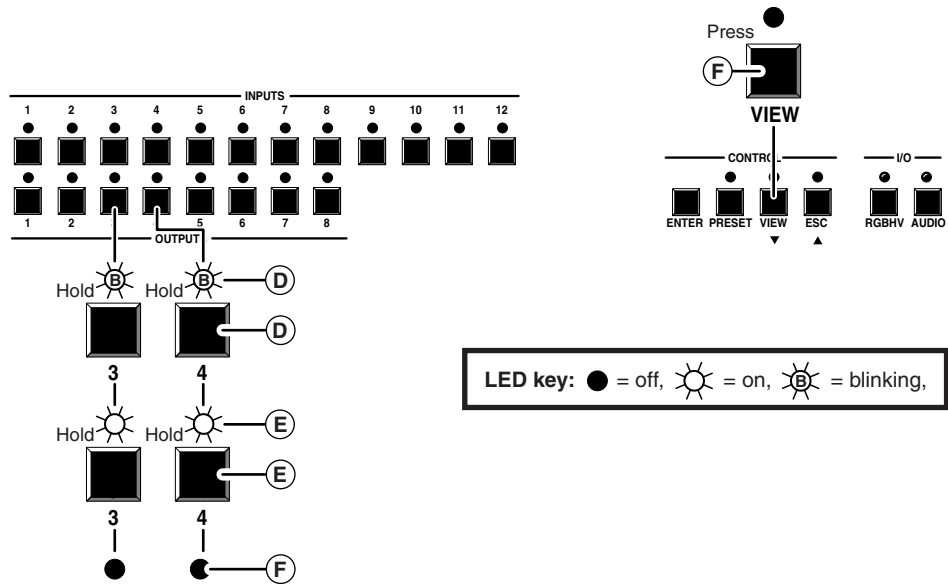
See figure 3-9, on page 3-10, and figure 3-13 and the following steps for an example of muting and unmuting several CrossPoint Plus switcher outputs.

**NOTE** Figure 3-9 shows the process of viewing the current configuration after the steps in Examples 1, 2, and 3 have been completed.

- (A) Press and release the Esc button. The Esc LED flashes once.
- (B) Press and release the View button to enter view-only mode. The View LED lights.
- (C) To select both video and audio for viewing, if necessary, press and release the RGBHV and Audio buttons until the RGBHV LED and Audio LED light. With no input LED selected, all output LEDs that have no established ties light.
- (D) **One at a time**, press and **hold** the Output 3 and Output 4 buttons (figure 3-13) for approximately 2 seconds until the associated output LED begins to blink. The output 3 and output 4 video and audio signals are muted.

**NOTE** Figure 3-13 shows only the indications directly related to the mute operation. Indications from existing ties are not shown to avoid confusion.

- (E) **One at a time**, press and **hold** the Output 3 and Output 4 LEDs for approximately 2 seconds until the associated output LED lights steadily. The output 3 and output 4 video and audio signals are unmuted.
- (F) Press and release the View button to exit view-only mode. The View LED and all input and output LEDs go out.



**Figure 3-13 — Example 5, step d: Muting and unmuting outputs**

## Using presets

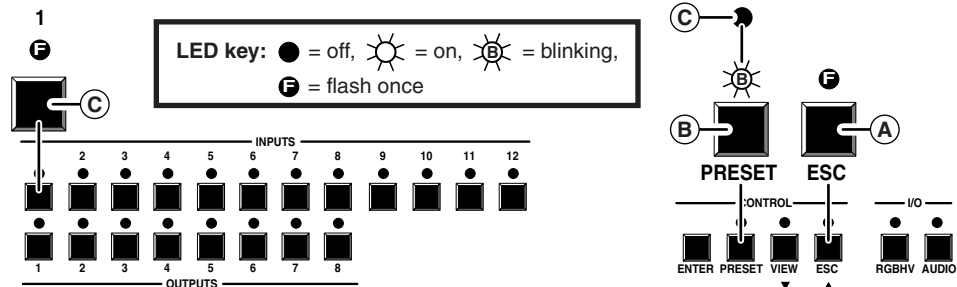
The current configuration (configuration 0) can be saved as a preset in any 1 of 16 preset memory addresses. Each CrossPoint Plus switcher has as many presets available from the front panel as input buttons. On the CrossPoint Plus 84, 88, 124, and 128, the extra presets can be saved or stored via the RS-232/422 link only.

- NOTE**
1. Only the audio and video ties are stored and recalled; audio gain settings are not saved, and they do not change when a preset is recalled.
  2. Presets cannot be viewed from the front panel unless recalled as the current configuration. Presets can be viewed using Extron's Windows-based control program, see chapter 5, *Matrix Software*, for more details.
  3. The current configuration and all presets are stored in non-volatile memory. When power is removed and restored, the current configuration is still active and all presets are retained.
  4. When a preset is recalled, it replaces the current configuration, which is lost unless it is also stored as a preset. The recalled preset overwrites all of the current configuration ties in favor of the preset configuration ties.

## Operation, cont'd

### Example 6: Save a preset

Refer to figure 3-14 and the following steps for an example of saving the current configuration as a preset.

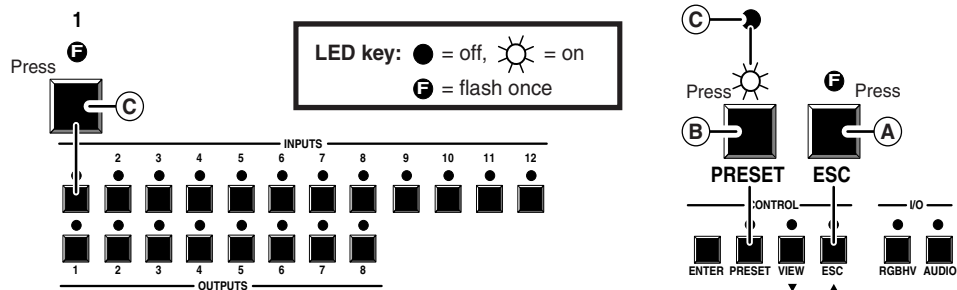


**Figure 3-14 — Example 6: Saving the current configuration as preset 1**

- (A) Press and release the Esc button. The Esc LED flashes once.
- (B) Press and **hold** the Preset button for approximately 2 seconds until the Preset LED begins to blink, then release the Preset button.
- (C) Press and release the input 1 button. The input 1 LED flashes once. The Preset LED turns off.

### Example 7: Recall a preset

Refer to figure 3-15 and the following steps for an example of recalling a preset to become the current configuration.



**Figure 3-15 — Example 7: Recalling preset 1**

- (A) Press and release the Esc button. The Esc LED flashes once.
- (B) Press and release the Preset button. The Preset LED lights.
- (C) Press and release the input 1 button. The input 1 LED flashes once. The Preset LED turns off. The configuration stored in memory location 1 is now the current configuration and can be viewed in the view-only mode (Example 4).

## Viewing and adjusting the input audio level (HVA models only)

On HVA models, the audio level of each input can be displayed and adjusted through a range of -15dB to +9dB to ensure that there is no noticeable volume difference among sources. The audio level can be adjusted from the front panel or by using Extron's Windows-based control program.

1. Press and **hold** the Audio button until the Audio LED begins to blink, then release the Audio button.
2. Press and release an input button to select an input. The audio level for the selected input is displayed in the output LEDs and the polarity (+ or -) is displayed in the View or Esc LEDs.
3. Press and release the Esc (▲) and View (▼) buttons to increase and decrease the audio level.
4. Press and release the Audio button to exit the audio display and adjust mode. The Audio LED stops blinking and turns off.

- NOTE**
1. There is one audio level setting per input. The audio level setting is shared by the left and right audio inputs.
  2. The audio level settings are stored in non-volatile memory. When power is removed and restored, the audio level settings are retained.

### Example 8: View and adjust an audio level

Refer to figure 3-16, figure 3-18, and the following steps for an example of viewing and adjusting the audio level. Audio gain and attenuation is displayed differently on the CrossPoint Plus 168 and 1616, but the steps for displaying the value are the same. For this reason, figure 3-17 and figure 3-19 show the indications displayed on the CrossPoint Plus 168 and 1616 without duplicating all of the actions shown in figure 3-16 and figure 3-18.

- A Press and release the Esc button. The Esc LED flashes once.
- B Press and **hold** the Audio button for approximately 2 seconds until the Audio LED begins to blink, then release the Audio button.
- C Press and release the input 5 button. The input 5 LED lights. The audio level for the selected input is displayed in the output LEDs. The polarity is indicated by either the Esc (▲) or View (▼) LED blinking.

On the CrossPoint Plus 84, 88, 124, and 128, each output LED indicates 1dB when blinking and 2dB when lit.

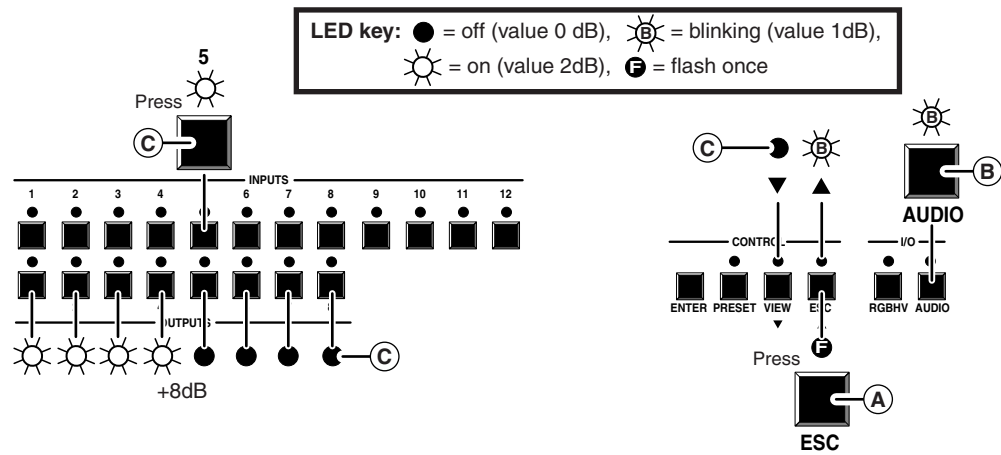
On the CrossPoint Plus 168 and 1616, each output LED indicates 1dB when lit.

The blinking Esc (▲) LED indicates a positive (gain) level. The blinking View (▼) LED indicates a negative (attenuation) level.

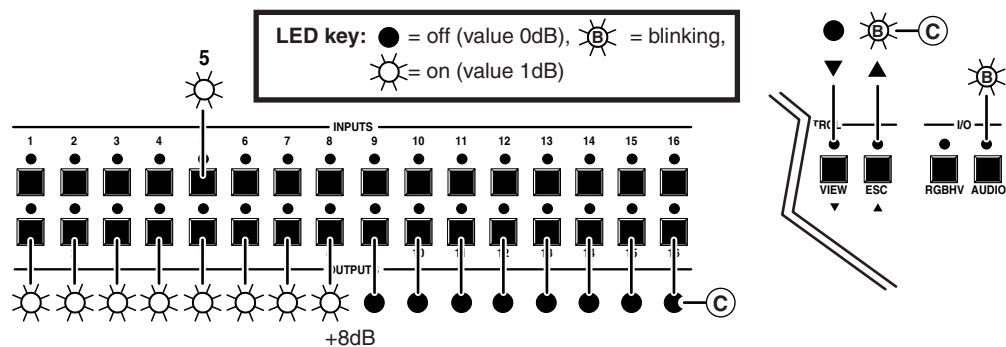
CrossPoint Plus 84, 88, 124, 128										
dB	Output LED								View Esc	
	1	2	3	4	5	6	7	8	▼	▲
+9	●	●	●	●	●	●	●	●	●	●
+8	●	●	●	●	●	●	●	●	●	●
+7	●	●	●	●	●	●	●	●	●	●
+6	●	●	●	●	●	●	●	●	●	●
+5	●	●	●	●	●	●	●	●	●	●
+4	●	●	●	●	●	●	●	●	●	●
+3	●	●	●	●	●	●	●	●	●	●
+2	●	●	●	●	●	●	●	●	●	●
+1	●	●	●	●	●	●	●	●	●	●
0	●	●	●	●	●	●	●	●	●	●
-1	●	●	●	●	●	●	●	●	●	●
-2	●	●	●	●	●	●	●	●	●	●
-3	●	●	●	●	●	●	●	●	●	●
-4	●	●	●	●	●	●	●	●	●	●
-5	●	●	●	●	●	●	●	●	●	●
-6	●	●	●	●	●	●	●	●	●	●
-7	●	●	●	●	●	●	●	●	●	●
-8	●	●	●	●	●	●	●	●	●	●
-9	●	●	●	●	●	●	●	●	●	●
-10	●	●	●	●	●	●	●	●	●	●
-11	●	●	●	●	●	●	●	●	●	●
-12	●	●	●	●	●	●	●	●	●	●
-13	●	●	●	●	●	●	●	●	●	●
-14	●	●	●	●	●	●	●	●	●	●
-15	●	●	●	●	●	●	●	●	●	●

## Operation, cont'd

Figure 3-16 and figure 3-17 show an audio level of +8dB displayed in the output LEDs on the two different CrossPoint Plus front panels.



**Figure 3-16 — Example 8: Viewing the audio level, CrossPoint Plus 84, 88, 124, and 128**

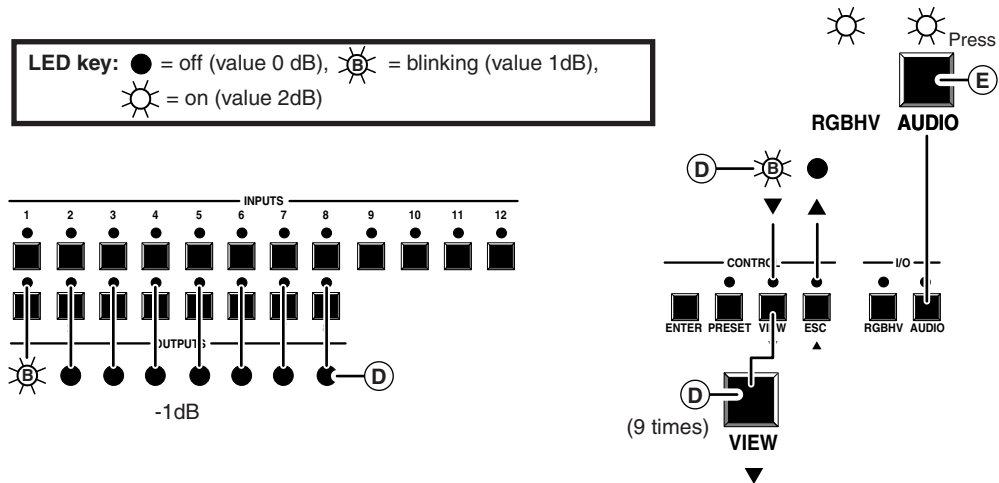


**Figure 3-17 — +8dB displayed, CrossPoint Plus 168 and 1616**

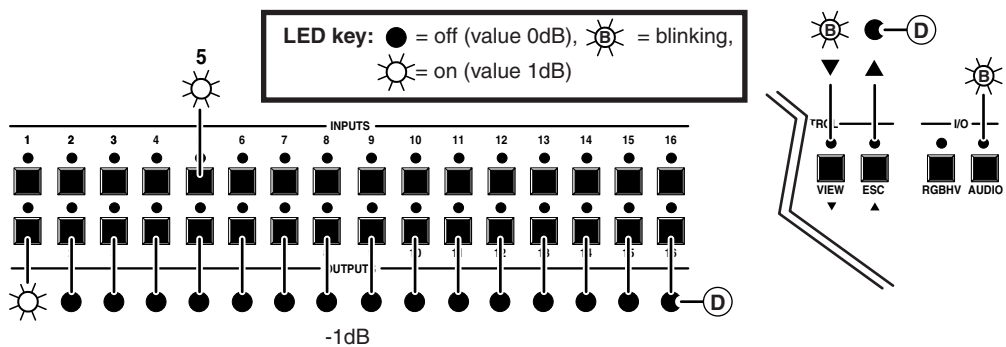
- Ⓓ Press and release the View (▼) button once to decrease the audio level displayed in the output LEDs by 1dB. Press and release the View (▼) button several more times to decrease the audio level displayed in the output LEDs by an additional 1dB per button push. Note the output LED, View LED, and Esc LED changes that occur each time the View (▼) button is pressed and released. Figure 3-18 and figure 3-19 show the result of pressing the View (▼) button a total of 9 times.

Both figures show an audio level of -1dB. Note that the Esc (▲) LED has turned off and that the View (▼) LED is blinking to indicate a negative level.





**Figure 3-18 — Example 8, step d: Adjusting the audio level, CrossPoint Plus 84, 88, 124, and 128**



**Figure 3-19 — -1dB displayed, CrossPoint Plus 168 and CrossPoint Plus 1616**

**NOTE** If another input button is pressed and released, the level value for the current input is saved and level value for the newly selected input is displayed.

(E) Press and release the Audio button. The Audio LED stops blinking and the View (▼) LED (if lit), the Esc (▲) LED (if lit), the selected input LED, and all output LEDs turn off.

**NOTE** Both the RGBHV and Audio LEDs light.

### Executive mode (front panel security lockout)

The executive mode limits the operation of the CrossPoint Plus switcher from the front panel. When the switcher is in executive mode, all of the front panel functions are disabled except for the view-only mode functions (see *Viewing a configuration* on page 3-9). Other than in view-only mode, if the user pushes a front panel button when the switcher is in executive mode, that button's associated LED flashes twice and goes out.

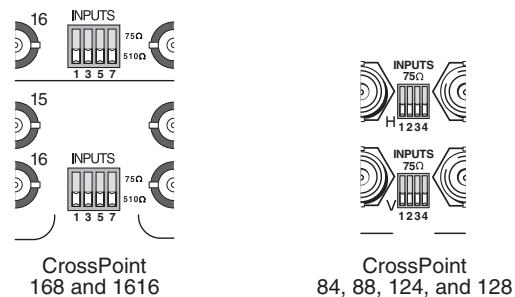
To toggle executive mode on or off, press and hold the RGBHV and Audio buttons for approximately two seconds. The RGBHV and Audio LEDs blink twice to indicate the mode change. Release the RGBHV and Audio buttons. To toggle the executive mode state again, press and hold the RGBHV and Audio buttons again.

### System reset to factory defaults

To reset the switcher to the factory default settings, press and hold the Esc button on the front panel while AC power is being applied. Continue to hold the Esc button until the power up sequence is completed (all LEDs turn off, the Video and Audio LEDs turn on, the Esc LED blinks, and the Power LED (if equipped) turns on). System reset clears all ties and presets, the RGB delay, the mutes, and the I/O grouping to the factory defaults and sets all audio gain levels to unity gain (+0dB).

### Rear Panel Controls

The CrossPoint Plus matrix switchers all have sync termination switches on the rear panel for inputs 1, 3, 5, and 7 on the CrossPoint Plus 168 and 1616 models and inputs 1 through 4 (figure 3-20) on the CrossPoint Plus 84, 88, 124, and 128 models. The switches provide a way to condition non-TTL sync levels greater than 5Vp-p, enabling the sync to be properly passed from input to selected output(s). The matrix switchers have two sets of sync termination switches; one for horizontal or combined sync and a second set for vertical sync.



**Figure 3-20 — Rear panel sync termination switches**

Each switch provides the option of selecting either 510 ohms or 75 ohms. The 75 ohms position is required only for an input with non-TTL sync, greater than 5V p-p. The normal position is 510 ohms.

**NOTE** *An input that produces an out of sync display, a display that is rolling vertically and/or tearing horizontally, could indicate a non-TTL sync input. A device that is known to output non-TTL sync levels (greater than 5V p-p) should be connected to one of the inputs with sync termination switches, and the switches for that input should be set to the 75 ohm position. If you're not sure, check the specifications in the user's manual for the input device.*

### Troubleshooting

This paragraph gives recommendations on what to do if you have problems operating the CrossPoint Plus, and it provides examples and descriptions for some image problems you may encounter.

#### General checks

1. Ensure that all devices are plugged in and powered on. The switcher is receiving power if one of the input LEDs is lit.
2. Ensure an active input is selected for output on the switcher.
3. Ensure that the proper signal format is supplied.
4. Check the cabling and make corrections as necessary.
5. Call the Extron S<sup>3</sup> Sales & Technical Support Hotline if necessary.

## Plasma display S-video problem

Extron has encountered a problem with the S-video output by some video conference codecs, when it is switched using a CrossPoint Plus. Some codecs change the DC offset on the chrominance (C) so that it is very different from the level on the luminance (Y). This can cause a plasma display to come up in the wrong size mode.

With the matrix switcher taken out of the system, the plasma works fine. It looks like a Extron problem, but **it is not**. The matrix switcher boosts the bad codec output, which makes the plasma go to the wrong setting.

**Solution:** Try placing an Extron video DC block adapter, part #26-495-01, on the luminance (Y) input to the switcher from the codec.

## Worksheets

Rather than trying to remember the configuration for each preset, use worksheets to record this information. Make copies of the blank worksheets on page 3-19 and use one for each preset configuration. The forms accommodate all of the CrossPoint Plus models. Cross off all unused or inactive inputs and outputs. Use different colors for video and audio.

### Worksheet example 1: Entering system equipment

Figure 3-21 shows a worksheet for a CrossPoint Plus 128 HVA in a fictional organization with the system hardware annotated. Inputs 10 and 11 and output 7 have no connections in this organization, so they have been crossed out on the worksheet. On this example, preset 3 is used for the weekly status meeting. Choose your own method of notation.

Input sources												
Camera/ mic - Main Podium	Camera #2	PC 1 RGB 202	PC 2 RGB 202	Audio Tape	Classroom #1 VCR (Lancia)	Classroom #2 VCR (Lancia)	Laptop RGB 202	Rack DVD (DV5 100)	X	X	VTG 200	X
1	2	3	4	5	6	7	8	9	10	11	12	13

1	2	3	4	5	6	7	8	9	10	11
Main hall FP 1	Main hall FP #2	Podium monitor	Sound system #1	Sound system #2	VCR (VSC 75)	X	ADA	X	X	λ

**Output destinations**

Preset # 3 Title: Weekly status mtg Video:          Audio:         

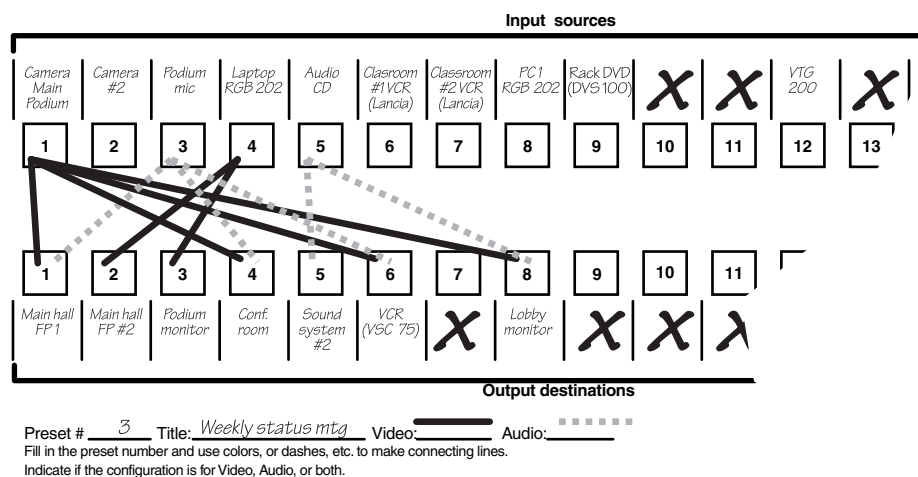
Fill in the preset number and use colors, or dashes, etc. to make connecting lines.  
Indicate if the configuration is for Video, Audio, or both.

**Figure 3-21 — Worksheet example 1: System equipment**

# Operation, cont'd

## Worksheet example 2: Drawing ties

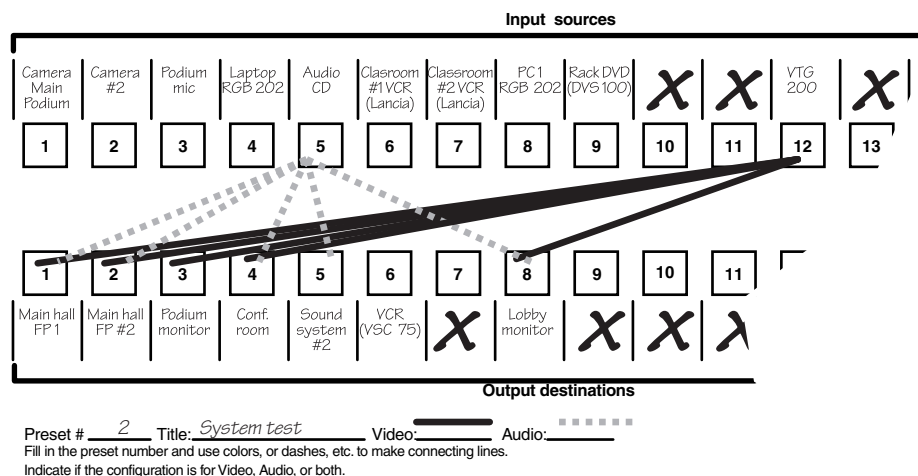
Figure 3-22 continues from worksheet example 1 by showing the video and audio ties that make up the configuration of preset 3, a solid ink line shows video ties, and a dashed pencil line shows the audio ties. In this example, the image of the presenter, from the main podium camera (input 1), is displayed in the main hall (output 1), to the overflow crowd in the conference room (output 4), and in the lobby (output 8). The image is also tied to the VCR (output 6). The presenter has a presentation on her laptop computer (input 4) that is displayed in the main hall (output 2) and locally on the podium (output 3). The audio from her microphone (input 3) is played in the hall (output 1), in the conference room (output 4), and sent to the VCR. Classical music from the CD player (input 5) is being played in the background in the main hall on sound system #2 (output 5), and in the lobby (output 8).



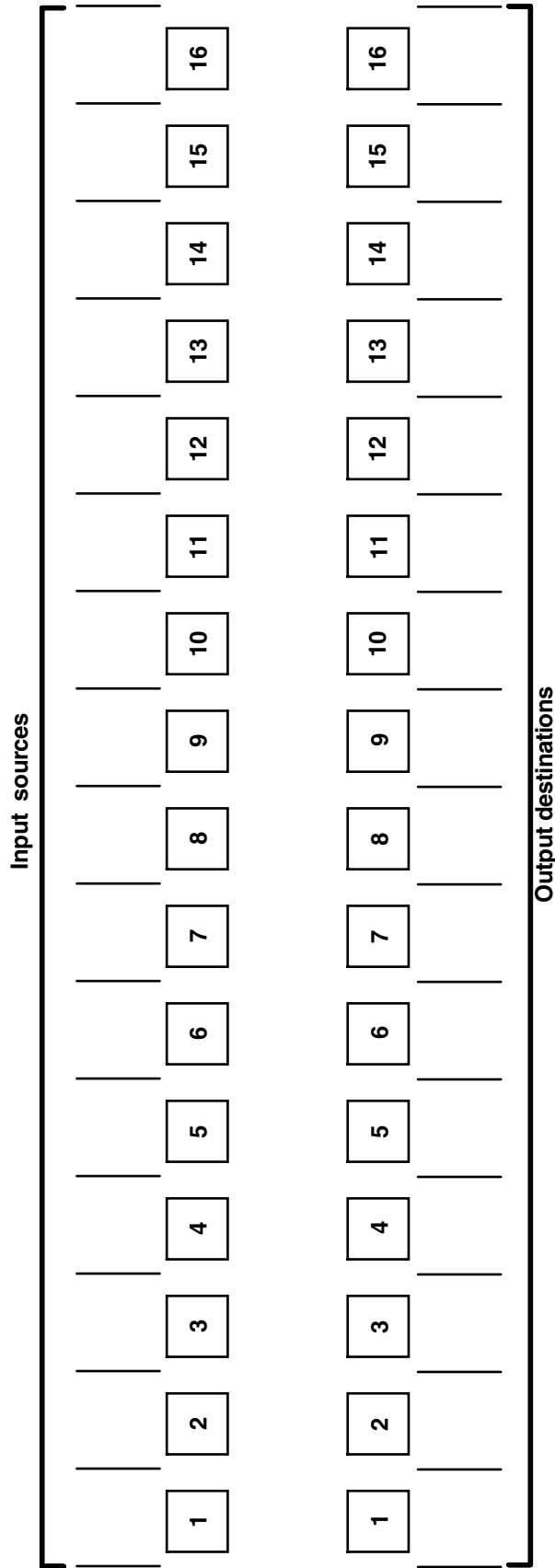
**Figure 3-22 — Worksheet example 2: Status meeting configuration**

## Worksheet example 3: Test configuration

The A/V system in our fictional organization needs to be fine tuned on a regular basis. Figure 3-23 shows a typical test configuration, with an Extron video test generator (input 12) generating a test pattern to all monitors (outputs 1, 2, 3, 4, and 8). Sound checks are run from the CD player (input 5) to all audio systems (outputs 1, 2, 4, 5, and 8).



**Figure 3-23 — Worksheet example 3: Test configuration**



Preset # \_\_\_\_\_ Title: \_\_\_\_\_ Video: \_\_\_\_\_ Audio: \_\_\_\_\_  
 Fill in the preset number and use colors, or dashes, etc. to make connecting lines.  
 Indicate if the configuration is for video, audio, or both.

### Matrix Switchers Configuration Worksheet

## Operation, cont'd

---



## CrossPoint Plus Matrix Switchers

# 4 Chapter Four

## Programmer's Guide

Host-to-Switcher Instructions

Switcher-Initiated Messages

Switcher Error Responses

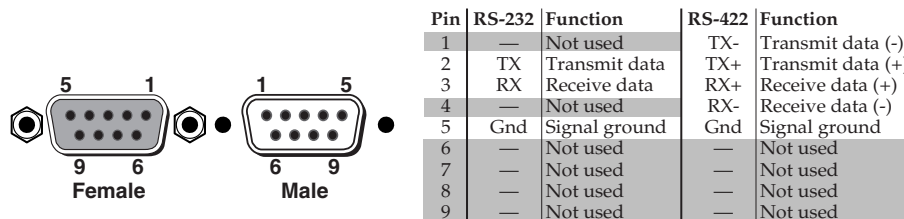
Using the Command/Response Table

Command/Response Table



# Programmer's Guide

The switcher's rear panel RS-232/RS-422 connector (figure 4-1) can be connected to the serial port output of a host device such as a computer, RS-232 capable PDA, or control system. This connection makes software control of the switcher possible.



**Figure 4-1 — RS-232/RS-422 connector pin arrangement**

**NOTE** The CrossPoint Plus Series Matrix Switchers are factory configured for RS-232 control. To use the switcher under RS-422 control, an internal cable must be moved. Refer to appendix B for the procedure for moving the cable.

The RS-232/RS-422 connector on the CrossPoint Plus Series switcher is a 9-pin D female connector with pin assignments as shown in figure 4-1.

The protocol is 9600 baud, 8-bit, 1 stop bit, no parity, and no flow control.

## Host-to-Switcher Instructions

The switcher accepts SIS (Simple Instruction Set) commands through the RS-232/RS-422 port. SIS commands consist of one or more characters per command field. They do not require any special characters to begin or end the command character sequence. Each switcher response to an SIS command ends with a carriage return and a line feed (CR/LF = ↵), which signals the end of the response character string. A string is one or more characters.

## Switcher-Initiated Messages

When a local event such as a front panel operation occurs, the switcher responds by sending a message to the host. The switcher-initiated messages are listed below (underlined).

(C) Copyright 2002, Extron Electronics "CrossPoint/Mav/Matrix", Vx.xx ↵

The copyright message is initiated by the switcher when it is first powered on. Vx.xx is the firmware version number.

RECONFIG ↵

The reconfig message is initiated by the switcher when a front panel operation has occurred, an audio gain adjustment has been completed, or a memory preset has been recalled.

RAM Test Failed ↵

ROM Checksum Failed ↵

EEPROM Reset (Presets/Attenuators) ↵

Serial EEPROM Reset (Current Settings) ↵

Invalid Jumpers ↵

If an error occurs during power-up, the switcher initiates one or more of the messages listed above.

All Configuration Memory Cleared ↵

The memory cleared message is initiated by the switcher when a system reset has occurred. See *System reset to factory defaults* in chapter 3.

The switcher does not expect a response from the host, but, for example, the host program might request a new status.

## Switcher Error Responses

When the switcher receives an SIS command and determines that it is valid, it performs the command and sends a response to the host device. If the switcher is unable to perform the command because the command is invalid or contains invalid parameters, the switcher returns an error response to the host. The error response codes are:

- E01 — Invalid input channel number (too large)
- E10 — Invalid command
- E11 — Invalid preset number (too large)
- E12 — Invalid output number (too large)
- E13 — Invalid value (out of range)
- E14 — Illegal command for this configuration
- E17 — Timeout (only caused by direct write of global presets)

## Using the Command/Response Table

The command/response table begins on the next page. Lower case letters are acceptable in the command field only where indicated. Symbols are used throughout the table to represent variables in the command/response fields. Command and response examples are shown throughout the table.

ASCII to HEX Conversion Table												Esc 1B	CR 0D	LF 0A			
Space 20	!	21	"	22	#	23	\$	24	%	25	&	26	'	27			
( 28	)	29	*	2A	+	2B	,	2C	-	2D	.	2E	/	2F			
0 30	1	31	2	32	3	33	4	34	5	35	6	36	7	37			
8 38	9	39	:	3A	;	3B	<	3C	=	3D	>	3E	?	3F			
@ 40	A	41	B	42	C	43	D	44	E	45	F	46	G	47			
H 48	I	49	J	4A	K	4B	L	4C	M	4D	N	4E	O	4F			
P 50	Q	51	R	52	S	53	T	54	U	55	V	56	W	57			
X 58	Y	59	Z	5A	[	5B	\	5C	]	5D	^	5E	_	5F			
` 60	a	61	b	62	c	63	d	64	e	65	f	66	g	67			
h 68	i	69	j	6A	k	6B	l	6C	m	6D	n	6E	o	6F			
p 70	q	71	r	72	s	73	t	74	u	75	v	76	w	77			
x 78	y	79	z	7A	{	7B		7C	}	7D	~	7E	DEL	7F			

# Programmer's Guide, cont'd

## Command/Response Table

### Symbol Definitions:

- ↵ = Carriage return/line feed
- ← = Carriage return (no line feed)
- = space

<b>[x1]</b>	= Input number	01 – 08 (CrossPoint Plus 84, 88); 01 – 12 (CrossPoint Plus 124, 128); 01 – 16 (CrossPoint Plus 168, 1616)
<b>[x2]</b>	= Output number	01 – 04 (CrossPoint Plus 84, 124); 01 – 08 (CrossPoint Plus 88, 128, 168); 01 – 16 (CrossPoint Plus 1616)
<b>[x3]</b>	= Input number (for tie)	0 – maximum number of inputs (0=disconnected)
<b>[x4]</b>	= Frequency	xxx.xx (frequency in Hz (vertical) or kHz (horizontal))
<b>[x5]</b>	= Group	0 – 4 (0 = not assigned to a group)
<b>[x6]</b>	= RGB delay	0 – 10 (0 to 5 seconds, 0.5 seconds/step)
<b>[x7]</b>	= Audio gain	0 – 9 (1dB/step)
<b>[x8]</b>	= Audio attenuation	1 – 15 (1dB/step)
<b>[x9]</b>	= Numeric dB value	-15 to +09
<b>[x10]</b>	= Preset number	00 – 16 (0 = current configuration)
<b>[x11]</b>	= Preset number	01 – 16
<b>[x12]</b>	= Mute status	0 = no mute, 1 = video mute, 2 = audio mute, 3 = V and A mute
<b>[x13]</b>	= Executive mode, mute	1 = on, 0 = off
<b>[x14]</b>	= Controller software version number to second decimal place	

**NOTE** *Input and output numbers in commands may be entered as either 1-digit or 2-digit numbers. All input and output numbers are specified as 2-digit numbers in the response.*

### Command/response table for SIS commands

Command	ASCII Command (host to switcher)	Response (switcher to host)	Additional description
<b>Create ties</b>			
<b>Tie input [x3] to output [x2], A &amp; V</b> <i>Example:</i>	<b>[x3] * [x2] !</b> 1*3!	Out[x2]•In[x3]•All↵ Out03•In01•All↵	Tie input 1 A & V to output 3.
<b>Tie input to output, RGBHV only</b> <i>Example<sup>1</sup>:</i>	<b>[x3] * [x2] &amp;</b> 10*4&	Out[x2]•In[x3]•RGB↵ Out04•In10•RGB↵	Audio breakaway. Tie input 10 RGB to output 4.
<b>Tie input [x3] to output [x2], video only</b> <i>Example<sup>1</sup>:</i>	<b>[x3] * [x2] %</b> 7*5%	Out[x2]•In[x3]•Vid↵ Out05•In07•Vid↵	Audio breakaway. Tie input 7 video to output 5.
<b>Tie input [x3] to output [x2], audio only</b> <i>Example:</i>	<b>[x3] * [x2] \$</b> 12*8\$	Out[x2]•In[x3]•Aud↵ Out08•In12•Aud↵	Audio breakaway. Tie input 12 audio to output 8.
<b>Quick multiple tie</b> <i>Example:</i>	<b>[Esc]Q[x3]*[x2]!...[x3]*[x2]!←</b> [Esc]Q3*4!3*5!3*6!←	Out•Multi•In•Multi•All↵ Out•Multi•In•Multi•All↵	Tie input 3 to outputs 4, 5, and 6.
<b>Tie input to all outputs</b> <i>Example:</i>	<b>[x3]!</b> 5!	Out•Multi•In[x3]•All↵ Out•Multi•In05•All↵	Tie input 5 to all outputs.
<b>Digital Sync Validation Processing</b>			
<b>List individual sync (DSVP)</b> <i>Example:</i>	<b>[x1]LS</b> 2LS	In[x1]•Hrz=[x4]•Vrt=[x4]↵ In02•Hrz=031.50•Vrt=060.00↵	Input 2 frequency is 31.5 kHz horizontal and 60 Hz vertical

<sup>1</sup> The & tie command for RGB and the % tie command for video can be used interchangeably on the CrossPoint Plus models.

## Command/response table for SIS commands (Cont'd)

Command	ASCII Command (host to switcher)	Response (switcher to host)	Additional description
List all sync (DSVP)	LS	Input•Horz. •Vert. ↵ [X1]••[X4]•[X4] ↵ thru [X1]••[X4]•[X4] ↵ ↵	
<i>Example:</i>	LS	Input•Horz. •Vert. ↵ 01••031.50•060.00 ↵ thru 16••031.50•060.00 ↵ ↵	Input 1 (H) 31.5 kHz (V) 60 Hz thru Input 16 (H) 31.5 kHz (V) 60 Hz.
<b>I/O Grouping</b>			
Write input grouping	[Esc]i [X5]...[X5]	IWrt ↵	One [X5] entry for each input.
<i>Example:</i>	[Esc]i42...33	IWrt ↵	In1-Grp 4, In2-Grp 2,...In16-Grp 3.
Write output grouping	[Esc]o [X5]...[X5]	OWrt ↵	One [X5] entry for each output.
Read input grouping	[Esc]I	GrpI [X5]...[X5] ↵	One [X5] entry for each input.
Read output grouping	[Esc]O	GrpO [X5]...[X5] ↵	One [X5] entry for each output
<b>RGB delay</b>			
Set RGB delay	[X6]*[X2]D	Out[X2]•Dly[X6] ↵	
<i>Example:</i>	7*13D	Out13•Dly07 ↵	Sets the RGB interval for switches to output 13 to 3.5 sec. (7x0.5 sec.).
Read RGB delay	[X2]D	Out[X2]•Dly[X6] ↵	
<i>Example:</i>	13D	Out13•Dly05 ↵	Output 13 interval is 2.5 sec. (5 x 0.5 sec).
<b>Audio input gain and attenuation</b>			
Set audio input gain to +dB value	[X1] * [X7] G	In[X1]•Aud=[X9] ↵	
<i>Example:</i>	1*2G	In01•Aud=+02 ↵	Set input 1 audio gain to +2dB.
Set audio input attenuation to -dB value	[X1] * [X8] g	In[X1]•Aud=[X9] ↵	
Increment gain up	[X1]   G	In[X1]•Aud=[X9] ↵	
<i>Example:</i>	5   G	In05•Aud=+03 ↵	Audio input 5 level incremented from +2dB to +3dB.
Decrement gain down	[X1]   G	In[X1]•Aud=[X9] ↵	
<i>Example:</i>	7   G	In07•Aud=-09 ↵	Audio input 7 level decremented from -8dB to -9dB.
<b>Global presets</b>			
Save current configuration as preset	[X1] ,	Spr[X1] ↵	Command character is a comma.
<i>Example:</i>	9,	Spr09 ↵	Save current ties as preset 9.
Recall a preset	[X1] .	Rpr[X1] ↵	Command character is a period.
<i>Example:</i>	5.	Rpr05 ↵	Recall preset 5, which becomes the current configuration.

# Programmer's Guide, cont'd

## Command/response table for SIS commands (Cont'd)

Command	ASCII Command (host to switcher)	Response (switcher to host)	Additional description
Start direct write of global presets	<code>[Esc]P [X11] ←</code> {Tie commands}	Write Preset [X11] Ready ↵	Allows direct entry of presets. {Define ties for preset.}
End direct write of global presets	<code>[Esc]p ←</code>	End Write Preset [X11] ↵	Saves directly written presets.
Quick recall preset	<code>[Esc]. ←</code>	Rpr[X11] ↵	Command character is a period.
<b>NOTE</b>	<ol style="list-style-type: none"> <li>1. This sequence of commands forces the switcher to perform a complete backplane switch within 60 msec of receipt of the Quick recall command.</li> <li>2. The switcher ignores any invalid command or non-switching commands received between the Start and End commands.</li> <li>3. If there is no activity for 5 seconds, the switcher returns the timeout (E17) error.</li> <li>4. The switcher disables front panel switching during this sequence of commands.</li> <li>5. The switcher returns the invalid command (E10) error if it receives the End command without the start command or the Quick recall command without a prior direct preset write.</li> <li>6. The switcher must receive the Quick recall command within 100 msec of the End command.</li> </ol>		
Example:	<code>[Esc]P 14 ←</code> <code>1*3!</code> <code>7*8%</code> <code>10*4&amp;</code> <code>12*4\$</code> <code>[Esc]p ←</code> <code>[Esc]. ←</code>	Write Preset 14 Ready ↵      End Write Preset 14 ↵ Rpr[X11] ↵	Creates new preset 14 with: A & V Input 1 tied to output 3. Video input 7 tied to output 8'. RGB input 10 tied to output 4'. Audio input 12 tied to output 4.  Stops entry, saves preset 14. Recalls the preset.
<b>Video mute commands</b>			
Video mute	<code>[X2]*1B</code>	Vmt[X2]*1 ↵	Mute output [X2] video (video off).
Video unmute	<code>[X2]*0B</code>	Vmt[X2]*0 ↵	Unmute output [X2] video (video on).
Read video mute	<code>[X2]B</code>	[X13] ↵	1= mute on, 0 = mute off.
Global RGB mute	<code>1*B</code>	Vmt1 ↵	
Global RGB unmute	<code>0*B</code>	Vmt0 ↵	
<b>Audio mute commands</b>			
Audio mute	<code>[X2]*1Z</code>	Amt[X2]*1 ↵	Mute output [X2] video (audio off).
Audio unmute	<code>[X2]*0Z</code>	Amt[X2]*0 ↵	Unmute output [X2] video (audio on).
Read audio mute	<code>[X2]Z</code>	[X13] ↵	1= mute on, 0 = mute off.
Global audio mute	<code>1*Z</code>	Amt1 ↵	
Global audio unmute	<code>0*Z</code>	Amt0 ↵	
<b>Executive mode</b>			
Lock front panel	X	Exe1 ↵	Enable executive mode.
Unlock front panel	x	Exe0 ↵	Disable executive mode.
<b>Resets</b>			
Reset global presets	<code>[Esc]zG ←</code>	ZapG•• ↵	Clear all global presets.
Reset delays	<code>[Esc]zD ←</code>	ZapD•• ↵	Reset all switch intervals to 0 sec.
Reset audio levels	<code>[Esc]zA ←</code>	ZapA•• ↵	Reset all audio levels to 0dB.
Reset grouping	<code>[Esc]zP ←</code>	ZapP•• ↵	Reset all I/O grouping.

## Command/response table for SIS commands (Cont'd)

Command	ASCII Command (host to switcher)	Response (switcher to host)	Additional description
Reset all mutes	<code>EsczZ←</code>	ZapZ↵	Unmute all outputs.
Reset whole switcher	<code>EsczXXX←</code>	ZapXXX↵	Clears all ties and global presets, the RGB delay, the I/O grouping, and resets all audio gains to 0dB.
<b>View ties, gain, mutes, and presets</b>			
View video output tie <i>Example:</i>	V/v <code>x2</code> % v7%	Out <code>x2</code> •In <code>x3</code> •Vid↵ Out07•In02•Vid↵	Output 7 video tied to input 2 video.
View audio output tie <i>Example:</i>	V/v <code>x2</code> \$ V3\$	Out <code>x2</code> •In <code>x3</code> •Aud↵ Out03•In06•Aud↵	Output 3 audio tied to input 6 audio.
View gain for input <i>Example:</i>	V/v <code>x1</code> G v4G	In <code>x1</code> •Aud= <code>x9</code> ↵ In04•Aud=-02↵	Gain for input #4 is -2dB.
View all output mutes	VM/vm	<code>x12</code> •(up to 16)Mut↵	Each position listed in the response is an output, left = output 1, right = <i>n</i> ( <i>n</i> = the maximum number of outputs for this model).
<i>Example<sup>2</sup> (CrossPoint Plus 168):</i>	VM	0•1•0•2•0•3•0•0•Mut↵	
View preset configuration	V/v <code>x10</code> .	<code>x3</code> •(up to 16)•Vid• <code>x3</code> •(up to 16)•Aud↵	
<p><b>NOTE</b> Each position listed in the response is an output, left = output 1, right= output <i>n</i> (<i>n</i> is the maximum number of outputs). The number in each position is the input tied to the output represented by that position.</p> <p>Response description: Input# (I#) assigned to output# (O#)1•I# to O#2...I# to O#<i>n</i>•Vid•I# to O#1•I# to O#2...I# to O#<i>n</i>•Aud↵</p> <p><i>Example<sup>2</sup> (CrossPoint 128 Plus HVA):</i> V0. Preset #0 is current configuration.</p> <p>Video input 8 tied to output 2      Audio input 5 tied to output 2      No tied audio input</p> <p>Response = tied input: <code>08•08•08•08•07•09•11•03</code>•Vid•<code>05•05•05•05•07•09•11•00</code>•Aud↵</p> <p>Output: <code>01 02 03 04 05 06 07 08</code>      <code>01 02 03 04 05 06 07 08</code></p> <p>Video = Input (I) 8 is tied to outputs (O) 1–4; I7 — O5; I9 — O6; I11 — O7; I3 — O8.</p> <p>Audio = The same as video except that input 5 is tied to outputs 1–4 and no input is tied to output 8.</p>			
<b>Information requests</b>			
Information request <i>Example:</i>	I/i i	V <code>x1</code> X <code>x2</code> •A <code>x1</code> X <code>x2</code> •Exe <code>x13</code> ↵ V16X16•A16X16•Exe0↵	V <code>x1</code> X <code>x2</code> = V size, A <code>x1</code> X <code>x2</code> = A Size. 16 Video & 16 Audio inputs and outputs, front panel unlocked.
Request part number <i>Example:</i>	N/n N	Nxx-xxx-xx↵ N60-332-06↵	See appendix A for part #s. CrossPoint Plus 1616HVA part # is 60-332-06.
Query software version <i>Example:</i>	Q/q Q	Ver <code>x14</code> ↵ Ver2.00↵	The value shown is an example only.

<sup>2</sup> HV models do not display audio configuration or mutes, and the number of outputs shown varies with the number of video or audio outputs.

# Programmer's Guide, cont'd

---





## CrossPoint Plus Matrix Switchers

# 5 Chapter Five

## Matrix Software

Matrix Switchers Control Program

Button-Label Generator

# Matrix Software

---

Two software programs accompany the CrossPoint Plus Series switchers:

- The Extron Matrix Switcher+ Control Program (Extron part #29-015-01), which communicates with the switcher via the RS-232/RS-422 port, provides an easy way for you to set up ties and sets of ties.

**NOTE** *If your CrossPoint Plus Series switcher was previously set up for RS-232, and your computer comm port uses RS-422, you must change the switcher cabling to match the computer interface. See Appendix B, Reference Information, for details.*

- The Extron Button-Label Generator, which allows you to design and print labels for the CrossPoint Plus front panel buttons.

Both programs are compatible with Windows 95/98, Windows NT, Windows ME, and Windows 2000. Updates to these programs can be downloaded from the Extron Web site (<http://www.extron.com>).

## Matrix Switchers Control Program

### Installing the software

The program is contained on a set of 3.5-inch diskettes, and you should load and run the program from the hard drive.

To install the program from the floppy disk to the hard drive, run Setup.exe from the floppy disk and follow the instructions that appear on the screen. The program occupies approximately 1 MB (megabyte) of hard-drive space.

By default, the Windows installation creates a C:\MTRX directory, and it places two icons (Matrix Switcher+ Control Program and Matrix Switcher+ Help) into a group or folder named "Extron Electronics".

**NOTE** *The program was designed to control most Extron matrix switchers, but its operation is limited to the features and configuration of your CrossPoint Plus Series switcher.*

### Using the software

#### Overview

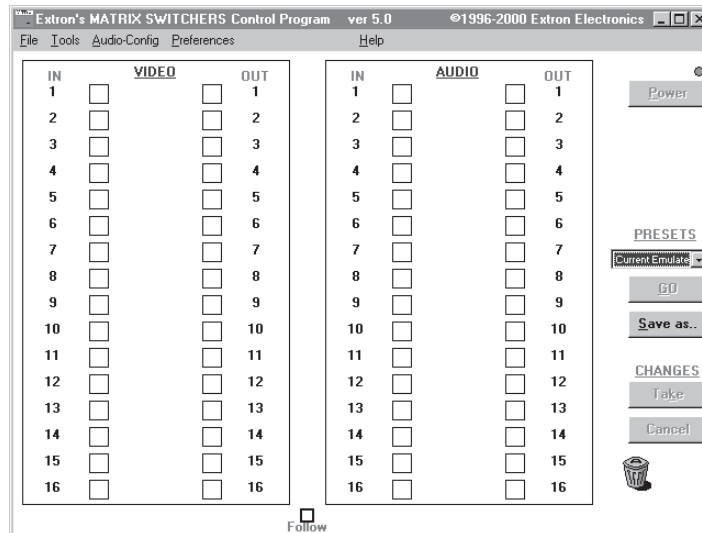
This section is an overview of the Extron Matrix Switcher+ Control Program. The help function contains additional information. See *Using the help system* on page 5-5 for details.

1. To run the Matrix Switcher+ Control Program, double-click on the Matrix Switcher+ Control Program icon (shown at right) in the Extron Electronics group or folder.
2. Click on the comm port that is connected to the RS-232/RS-422 port of the switcher. To set up the software without attaching the switcher to the computer, see *Using emulation mode* on page 5-5.

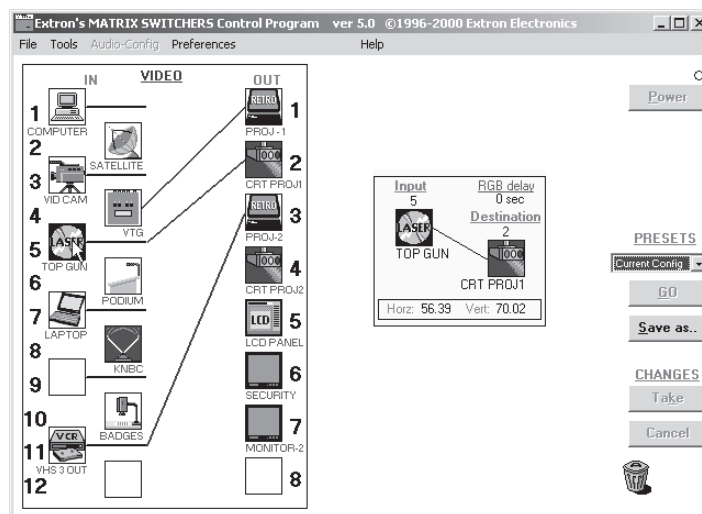


The Extron Matrix Switcher+ Control Program window (figure 5-1 and figure 5-2) displays the current configuration of the attached matrix.

3. To set up audio in follow mode (audio and video have the same tie configuration), select the Group box at the bottom of the window. To set up audio in breakaway mode (audio and video have different tie configurations), deselect the Group box.



**Figure 5-1 — Extron Matrix Switcher+ Control Program window (blank)**



**Figure 5-2 — Sample program window (complete)**

4. To make the control program easier to use, assign a device icon to each input and output. Click on a box that represents an input or output, and drag the desired icon onto the box from the icon palette that appears.
5. To create a tie, drag an input box to one or more output boxes. To remove a tie, drag the output box to its tied input box.
6. For quick display of information on a specific input or output, place the cursor over that device in the control program window. The program pops up a window that details the connections to that device, the switching interval (RGB delay), and the frequency of the video signal input from or output to that device.

#### Windows buttons

The buttons on the right side of the window perform the following functions:

**Power** — Unavailable for CrossPoint Plus Series switchers, because the switcher power cannot be controlled via software.

## Matrix Software, cont'd

---

**Executive mode** — Allows you to lock out front panel operations, except for the view-only mode functions.

**Presets menu** — Displays a list of up to 16 presets. You can select a preset from the list to display it in the window.

**Go** — Activates the selected preset as the current configuration.

**Save as** — Allows the current set of ties to be saved as a preset. Enter the preset number when prompted to do so.

**Changes - Take** — Allows you to save to file any changes made to the displayed configuration.

**Changes - Cancel** — Returns to the previous screen, undoing any changes you have made.

### Windows menus

#### File menu —

**Save matrix settings as** — Saves a complete set of up to 16 presets, plus the last active setting (preset #0), to a file. Saved settings include audio gain settings (if specified), assigned icons, and icon captions.

**Restore matrix settings from** — Loads and activates a previously saved setting file.

**Save this-session's settings** — Saves the current assigned icons and icon captions.

**Restore last-session's settings** — Loads the icons and icon captions that were saved during the last session. If you saved the previous session's changes to disk the last time you exited the program, the ties from that session are also loaded.

**Select printer** — Selects the target printer.

**Print tie map** — Prints the tie set that is displayed on the screen.

**Exit** — Closes the Extron Matrix Control Program.

#### Tools menu —

**Assign device icons** — Displays the complete set of input and output device icons. You can drag any of these icons to the input and output boxes.

**Edit device palette** — Allows you to add your own device icon graphics.

**RGB delay settings** — Displays the switching interval setting for each input and allows you to change them.

**Audio gain settings** — Displays the audio gain level setting for a single input or for all inputs and allows you to change it.

**View input frequencies** — (DSVP) Displays the input horizontal and vertical frequencies for each input.

**Name presets** — Allows you to assign a name to each of the 16 memory presets.

**Show RS-232 strings** — Displays the ASCII commands that are used by the current configuration. You can refer to these for RS-232 programming.

**I/O group settings** — Allows you to establish I/O groups.

**Initialize** — Initializes and clears any or all of the following: ties, presets, audio configuration, preset titles, icon names, and icons.

---

**Audio-config** — Displays the audio gain level settings for each input and allows you to change them.

**Preferences menu** —

**Immediate changes** — Causes changes to take effect immediately.

**Hold/verify changes** — Delays implementation of changes until the Changes – Take button is pressed.

**Ties as lines** — Displays ties as lines.

**Ties as crosspoints** — Displays ties as a grid of inputs and outputs.

**Frequency-read options** — Allows you to enable or disable periodic DSVP input frequency reads.

**Limit ties to same group** — Allows you to limit the creation of ties to within the same group (similar to front panel operation).

### Using emulation mode

Emulation mode allows you to set up the software without attaching the switcher to the computer. To use emulation mode, do the following:

1. Double-click on the Matrix Switchers Control Program icon in the Extron Electronics group or folder.
2. Choose Emulate, and click OK.
3. Choose an emulation file to open, and click OK. The file DEMO.MTX provides a sample of a completed matrix setup. The file NEW.INI provides a blank setup to get you started.
4. Enter the file name under which you want to save any changes to the file, and click OK.
5. Select the number of video boards, audio boards, and matrix model for which you are preparing a configuration, and click OK.
6. Continue using the program as described in steps 3 through 5, beginning on page 5-2.

### Using the help system

For information about program features, you can access the help program in any of the following ways:

- From the Extron Electronics program folder or group, double-click on the Matrix Switcher Help icon (shown at left).



MATRIX Switcher+  
Help

- From within the Matrix Switcher Control Program, click on the Help menu on the main screen.
- From within the Matrix Switcher Control Program, press the F1 key.

## Button-Label Generator

The program is contained on the same set of 3.5-inch diskettes as the Matrix Switcher+ Control Program and is installed automatically when you install that program.

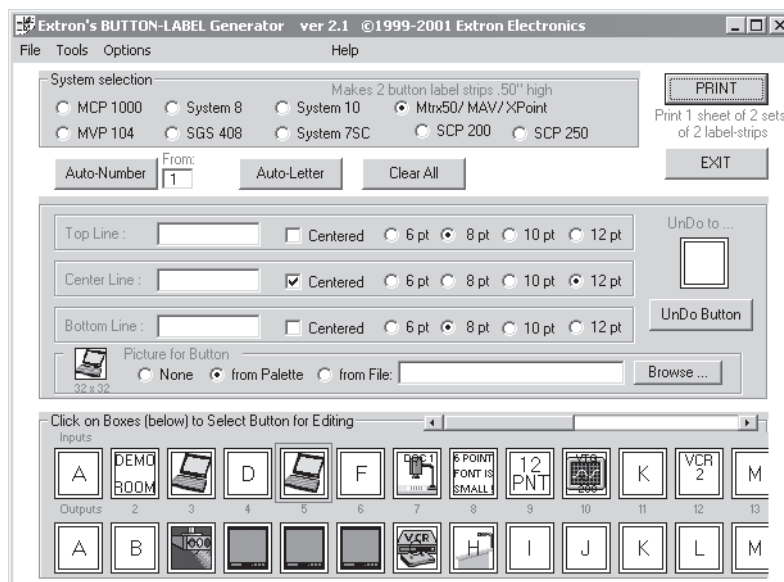
By default, the Windows installation goes in the C:\BUTTONS directory, and the Button-Label Generator icon is placed in the “Extron Electronics” group or folder.

# Matrix Software, cont'd

## Using the software

1. To run the Button-Label Generator program, double-click on the Button-Label Generator icon (shown at left) in the Extron Electronics group or folder, and click OK when prompted. The Extron's Button-Label Generator window appears (figure 5-3).
2. Under System selection, choose Mtrx50/MAV/XPoint.
3. Using normal Windows controls, you can create and print labels that can be placed in the label windows on the front panel of the switcher.

For information about using the program, you can access the help program by clicking on the Help menu on the main screen and choosing Show Help.



**Figure 5-3 — Extron's Button-Label Generator window**

You can also see an example of a completed Extron's Button-Label Generator window by clicking on the Help menu on the main screen, choosing Show Help, and clicking on the Load Demo button.



# CrossPoint Plus Matrix Switchers

# A

# Appendix A

## Specifications

Specifications

Part Numbers



# Specifications

---

## Video

Routing .....	84 Series .....	8 x 4 matrix
	88 Series .....	8 x 8 matrix
	124 Series .....	12 x 4 matrix
	128 Series .....	12 x 8 matrix
	168 Series .....	16 x 8 matrix
	1616 Series .....	16 x 16 matrix
Gain .....	Unity	
Bandwidth .....	425 MHz (-3dB), fully loaded	
	0 - 10 MHz .....	no more than +0.1dB to -0.1dB
	0 - 130 MHz .....	no more than +6dB to -0.8dB
Crosstalk .....	-80dB @ 1 MHz, -65dB @ 10 MHz, -55dB @ 30 MHz, -42dB @ 100 MHz	
Switching speed .....	200 ns (max.)	

## Video input

Number/signal type .....	8, 12, or 16 RGBHV, RGBS, RGsB, RsGsBs, HDTV, component video, S-video, composite video	
Connectors .....	84/88 Series .....	8 x 5 BNC female
	124/128 Series .....	12 x 5 BNC female
	168/1616 Series .....	16 x 5 BNC female
Nominal level .....	1V p-p for Y of component video and S-video, and for composite video	
	0.7V p-p for RGB	
	0.3V p-p for R-Y and B-Y of component video, and for C of S-video	
Minimum/maximum levels .....	Analog .....	0.5V to 2.0V p-p with no offset
Impedance .....	75 ohms	
Return loss .....	-30dB @ 5 MHz	
Maximum DC offset .....	1.5V	

## Video output

Number/signal type .....	4, 8, or 16 RGBHV, RGBS, RGsB, RsGsBs, HDTV, component video, S-video, composite video	
Connectors .....	84/124 Series .....	4 x 5 BNC female
	88/128/168 Series .....	8 x 5 BNC female
	1616 Series .....	16 x 5 BNC female
Nominal level .....	1V p-p for Y of component video and S-video, and for composite video	
	0.7V p-p for RGB	
	0.3V p-p for R-Y and B-Y of component video, and for C of S-video	
Minimum/maximum level .....	2V p-p	
Impedance .....	75 ohms	
Return loss .....	-30dB @ 5 MHz	
DC offset .....	±5mV maximum with input at 0 offset	
Switching type .....	Triple-Action™	

## Sync

Input type .....	RGBHV, RGBS, RGsB, RsGsBs	
Output type .....	RGBHV, RGBS, RGsB, RsGsBs	
Input level .....	0.5V to 5.0V p-p, 4.0V p-p normal	
Output level .....	AGC to TTL: 4V to 5V p-p	
Input impedance		
84/88/124/128 Series .....	Inputs 1 to 4 .....	75 or 510 ohms, switchable
	Inputs 5 to 12 .....	510 ohms
168/1616 Series .....	Inputs 1, 3, 5, 7 .....	75 or 510 ohms, switchable
	Inputs 2, 4, 6, 8, and 9 to 16 ...	510 ohms

---

Output impedance ..... 75 ohms  
Polarity ..... Positive or negative (follows input)

### Audio — audio models only

Routing ..... 84 Series ..... 8 x 4 stereo matrix  
88 Series ..... 8 x 8 stereo matrix  
124 Series ..... 12 x 4 stereo matrix  
128 Series ..... 12 x 8 stereo matrix  
168 Series ..... 16 x 8 stereo matrix  
1616 Series ..... 16 x 16 stereo matrix

Gain ..... Unbalanced output: 0dB, balanced output: +6dB

Frequency response ..... 20 Hz to 20 kHz,  $\pm 0.05$ dB

THD + Noise ..... 0.03% @ 1 kHz at rated nominal level

S/N ..... >90dB, balanced, at rated maximum output (21dBu)

Crosstalk ..... <-80dB @ 1 kHz, fully loaded

Stereo channel separation ..... >80dB @ 1 kHz

CMRR ..... >75dB @ 20 Hz to 20 kHz

### Audio input — audio models only

Number/signal type ..... 8, 12, or 16 stereo, balanced/unbalanced

Connectors ..... 84/88 Series ..... (8) 3.5 mm captive screw connectors, 5 pole  
124/128 Series ..... (12) 3.5 mm captive screw connectors, 5 pole  
168/1616 Series ..... (16) 3.5 mm captive screw connectors, 5 pole

Impedance ..... >10 kohm, balanced/unbalanced, DC coupled

Nominal level ..... -10dBV (316mV)

Maximum level ..... +19.5dBu, (balanced or unbalanced) at stated %THD+N

Input gain adjustment  
84/88/124/128/168/1616 Series  
-15dB to +9dB, adjustable per input by RS-232/422 or front panel

### Audio output — audio models only

Number/signal type ..... 4, 8, or 16 stereo, balanced/unbalanced

Connectors ..... 84/124 Series ..... 4 3.5 mm captive screw connectors, 5 pole  
88/128/168 Series .... 8 3.5 mm captive screw connectors, 5 pole  
1616 Series ..... 16 3.5 mm captive screw connectors, 5 pole

Impedance ..... 50 ohms unbalanced, 100 ohms balanced

Gain error .....  $\pm 0.1$ dB channel to channel

Maximum level (Hi-Z) ..... >+21dBu, balanced or unbalanced at stated %THD+N

Maximum level (600 ohm) ..... >+15dBm, balanced or unbalanced at stated %THD+N

**NOTE** 0dBu = 0.775 volts (RMS).

### Control/remote — switcher

Serial control port ..... 1 RS-232 or RS-422, 9-pin female D connector

Baud rate and protocol ..... 9600, 8-bit, 1 stop bit, no parity

Serial control pin configurations .... 2 = TX, 3 = RX, 5 = GND

Program control ..... Extron's control program for Windows  
Extron's Simple Instruction Set™ – SIS™

# Specifications, cont'd

## General

Power .....	100VAC to 240VAC, 50/60 Hz, internal, autoswitchable
	84/88/124/128 ..... 30 watts
	168/1616 ..... 36 watts
Temperature/humidity .....	Storage -40° to +158°F (-40° to +70°C) / 10% to 90%, non-condensing
	Operating +32° to +104°F (0° to +40°C) / 10% to 90%, non-condensing
Rack mount .....	Yes, with included parts
Enclosure type .....	Metal
Enclosure dimensions	
84/88/124/128 Series .....	5.25" H x 17.0" W x 9.4" D (3U high, full rack width)
	13.3 cm H x 43.2 cm W x 23.9 cm D
	(Depth excludes connectors. Width excludes rack ears.)
168/1616 Series .....	10.5" H x 17.0" W x 9.7" D (6U high, full rack width)
	26.7 cm H x 43.2 cm W x 24.6 cm D
	(Depth excludes connectors. Width excludes rack ears.)
Product weight	
84/88/124/128 Series .....	14.4 lbs (6.5 kg)
168/1616 Series .....	19.4 lbs (8.8 kg)
Shipping weight	
84/88/124/128 Series .....	21 lbs (9.5 kg)
	DIM weight ..... 25
168/1616 Series .....	26 lbs (11.8 kg)
	DIM weight ..... 34
Vibration .....	ISTA/NSTA 1A in carton (International Safe Transit Association)
Listings .....	UL, CUL
Compliances .....	CE, FCC Class A
MTBF .....	30,000 hours
Warranty .....	3 years parts and labor

**NOTE** Specifications are subject to change without notice.

## Part Numbers

### CrossPoint Plus part numbers

Extron Part	Part #
CrossPoint Plus 84HV	60-337-02
CrossPoint Plus 84HVA	60-337-01
CrossPoint Plus 88HV	60-336-02
CrossPoint Plus 88HVA	60-336-01
CrossPoint Plus 124HV	60-335-02
CrossPoint Plus 124HVA	60-335-01
CrossPoint Plus 128HV	60-334-02
CrossPoint Plus 128HVA	60-334-01
CrossPoint Plus 168HV	60-333-02
CrossPoint Plus 168HVA	60-333-01
CrossPoint Plus 1616HV	60-332-02
CrossPoint Plus 1616HVA	60-332-01
Matrix Switchers+ Control Program and Button-Label Generator	29-015-01
CrossPoint Plus Matrix Switchers User's Manual	68-521-01

---

## Optional accessories

Extron Part	Part #
Rack/desk mounting kit	70-077-03
MKP 1000	
Gray	60-239-01
Black	60-239-02
White	60-239-03
MCP 1000M (master)	60-298-01
MCP 1000S (slave)	60-298-02
Captive screw audio connector	10-319-10
RCA-to-BNC adapter	10-264-01
SVHS - BNC adapter	26-353-01

## Cables

When using signals with a scanning frequency of 15-125 kHz and running distances of 100 feet or more, use high resolution BNC cables to achieve maximum performance.

### Bulk cable

Extron Part	Part #
<b>RG6 super high resolution cable</b>	
RG6-1 bulk , 500'	22-098-02
RG6-1 bulk , 1000'	22-098-03
RG6-4 bulk , 500'	22-099-02
RG6-5 bulk , 500'	22-100-02
RG6 male crimp connectors, qty. 50	100-075-51
<b>BNC-4 Mini HR Cable</b>	
BNC-4 Mini HR bulk, 500'	22-032-02
BNC-4 Mini HR bulk, 1000'	22-032-03
<b>BNC-5 Mini HR Cable</b>	
BNC-5 Mini HR bulk, 500'	22-020-02
BNC-5 Mini HR bulk, 1000'	22-020-03
<b>Plenum BNC-5 Mini HR Cable</b>	
Plenum BNC-5 Mini HR bulk, 500'	22-103-02
Plenum BNC-5 Mini HR bulk, 1000'	22-103-03

### Assorted connectors

<b>BNC connectors</b>	
BNC Mini HR crimp connectors, qty. 50	100-074-51
RG6 male crimp connectors, qty. 50	100-075-51
BNC bulkhead connectors, qty. 50 (for custom wall plates)	100-076-51

## Specifications, cont'd

---

### Pre-cut cables

BNC-4 Mini HR cable is used for RGBS cable runs, and BNC-5 Mini HR cable is used for RGBHV cable runs. Either type can also be used for composite video, S-video, or RGsB. All Extron BNC cables have male connectors on both ends. A plenum version of the BNC-5 Mini HR cable is also available.

Extron Part	Part #
<b>BNC-4 Mini HR Cable</b>	
BNC-4-25' MHR (25 feet/7.5 meters)	26-210-04
BNC-4-50' MHR (50 feet/15.0 meters)	26-210-05
BNC-4-75' MHR (75 feet/23.0 meters)	26-210-06
BNC-4-100' MHR (100 feet/30.0 meters)	26-210-07
BNC-4-150' MHR (150 feet/45.0 meters)	26-210-08
BNC-4-200' MHR (200 feet/60.0 meters)	26-210-09
BNC-4-250' MHR (250 feet/75.0 meters)	26-210-54
BNC-4-300' MHR (300 feet/90.0 meters)	26-210-53
<b>BNC-5 Mini HR Cable</b>	
BNC-5-25' MHR (25 feet/7.5 meters)	26-260-03
BNC-5-50' MHR (50 feet/15.0 meters)	26-260-04
BNC-5-75' MHR (75 feet/23.0 meters)	26-260-16
BNC-5-100' MHR (100 feet/30.0 meters)	26-260-05
BNC-5-150' MHR (150 feet/45.0 meters)	26-260-12
BNC-5-200' MHR (200 feet/60.0 meters)	26-260-06
BNC-5-250' MHR (250 feet/75.0 meters)	26-260-18
BNC-5-300' MHR (300 feet/90.0 meters)	26-260-14

**NOTE** Bulk cable in lengths up to 5000' (1524 meter) rolls is available with or without connectors.



# CrossPoint Plus Matrix Switchers

# Appendix B

## Reference Information

Hardware Upgrades

Button Labels

# Reference Information

## Hardware Upgrades

This appendix contains procedures for performing hardware maintenance procedures such as swapping the RS-232 and RS-422 ports, installing a new firmware update, and replacing the fuse.

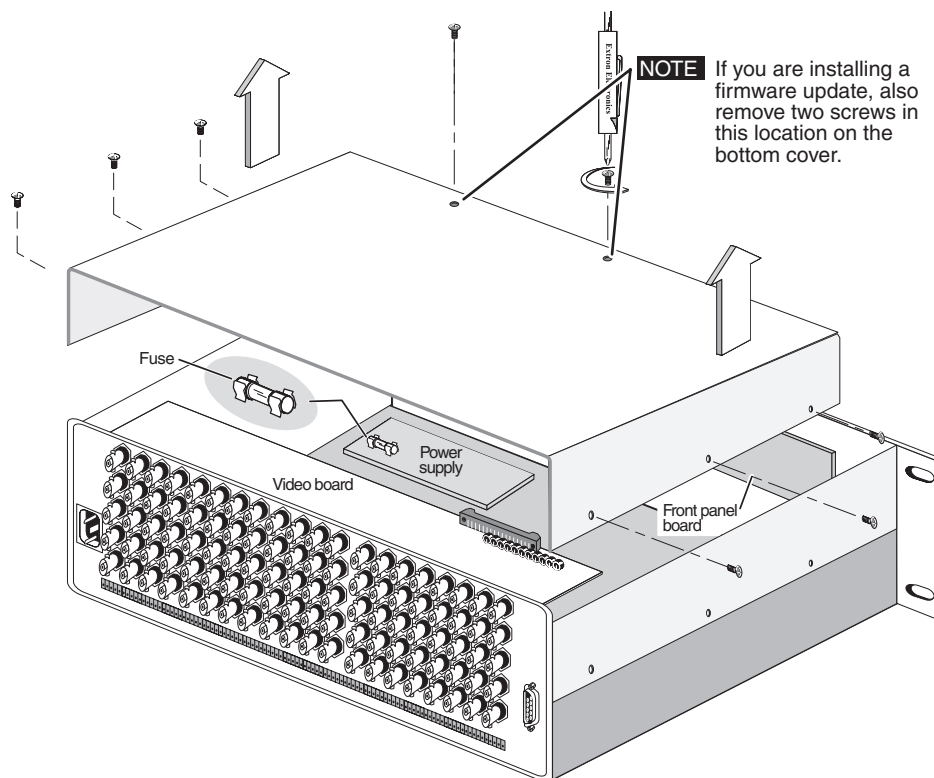
### Opening the switcher

Before you can perform any of the hardware upgrade procedures, you must open the switcher. The interior of the CrossPoint Plus 84, 88, 124, and 188 switchers is accessed by removing the top cover. The interior of the CrossPoint Plus 168 and 1616 is accessed by removing the front cover.

#### Opening the CrossPoint Plus 84, 88, 124, and 128

To open the CrossPoint Plus 84, 88, 124, or 128 switcher, do the following:

1. Disconnect the power cord from the switcher.
2. If the switcher is rack mounted, remove the switcher from the rack and place it on a clean workspace.
3. Remove the eight screws that secure the switcher's top cover as shown in figure B-1.

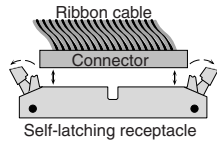


**Figure B-1 — Removing the top cover**

**CAUTION** Do not touch the components inside the switcher without being electrically grounded. Electrostatic discharge (ESD) can damage ICs, even if you cannot feel, see, or hear it.

4. Lift the top cover straight up as shown in figure B-1. Lift the cover evenly to clear the grooves at the edge of the rear panel.

5. If you are updating the firmware, remove the two screws at the front edge of the bottom cover, press the two receptacle tabs on the top cable outward as shown at the left, and pull back gently on the cable connector to remove it from the receptacle. Lay the front panel down in front of the switcher.



### Opening the CrossPoint Plus 168 and 1616

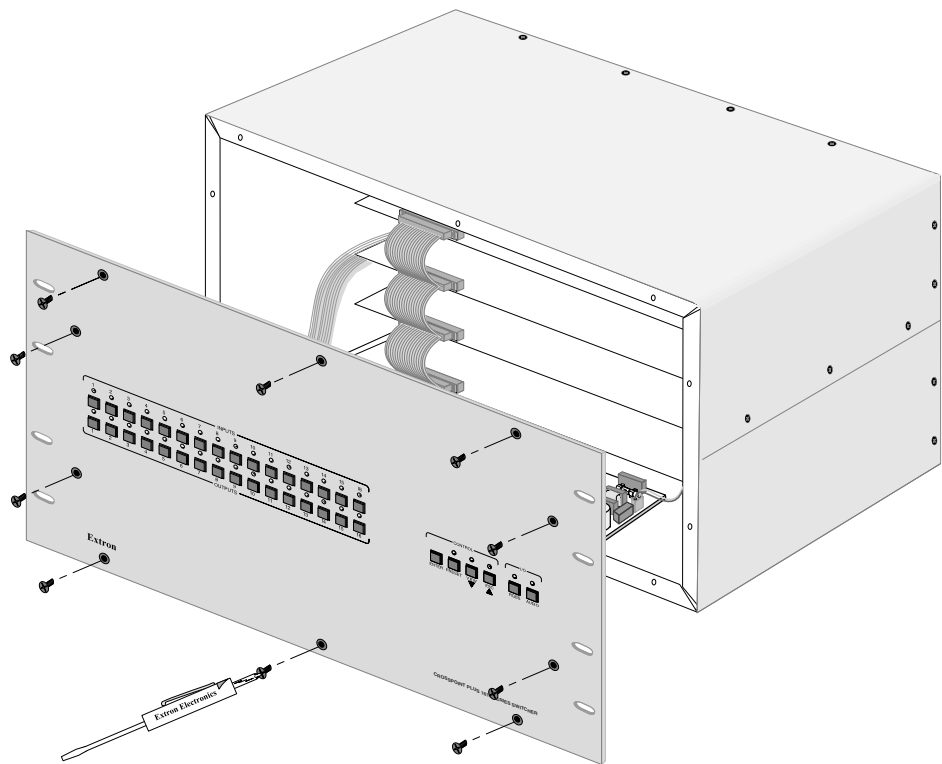
To open the CrossPoint Plus 168 or 1616 switcher, do the following:

1. Disconnect the power cord from the switcher.

**CAUTION** Do not strain the three internal cables connected to the front panel. Too much strain can damage the cables.

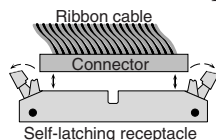
**CAUTION** Do not touch the components inside the switcher without being electrically grounded. Electrostatic discharge (ESD) can damage ICs, even if you cannot feel, see, or hear it.

2. Remove the ten screws that secure the switcher's front cover as shown in figure B-2. Carefully tilt the front panel away from the main body of the switcher.



**Figure B-2 — Removing the front cover**

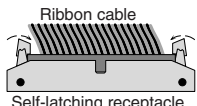
3. Press the two receptacle tabs on the top cable outward as shown at the left, and pull back gently on the cable connector to remove it from the receptacle. Lay the front panel down in front of the switcher.





## Reference Information, cont'd

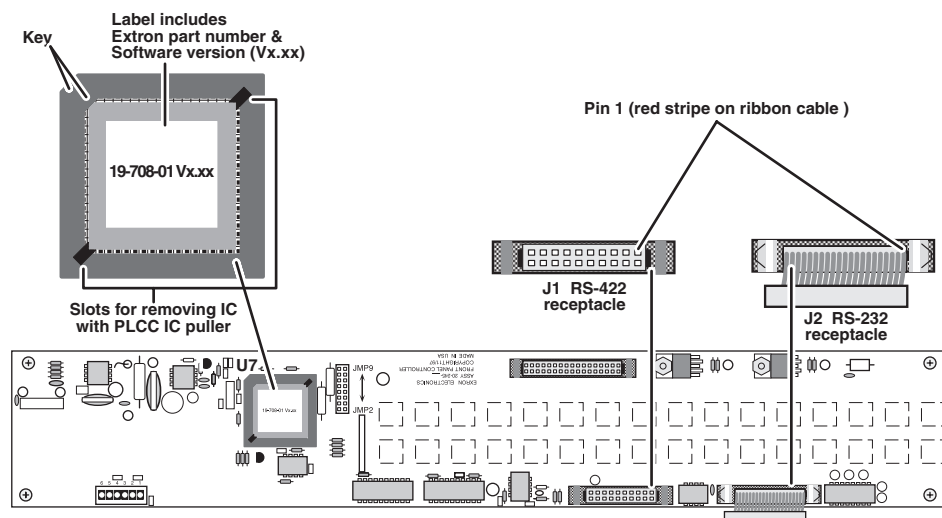
### Closing the switcher

1. Reinstall any cables removed. To plug a self latching cable into the desired receptacle, align the holes in the connector with the pins in the receptacle, and press evenly until the receptacle tabs lock into place.  
  
Ribbon cable  
Self-latching receptacle
2. Place the top cover (CrossPoint Plus 84, 88, 124, and 128) and/or front cover (all models) in place and replace all the screws removed in *Opening the switcher* on page B-2.

### Swapping the serial ports

The CrossPoint Plus switchers are factory configured for RS-232 use. If you want to use RS-422 and the switcher is configured for RS-232, or if you want to use RS-232 and the switcher is configured for RS-422, do the following:

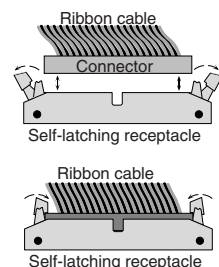
1. Follow the appropriate instructions in *Opening the Switcher* on page B-2 to gain access to the interior of your switcher.
2. Locate the switcher's front panel board (figure B-3).



**Figure B-3 — CrossPoint Plus front panel board**

**CAUTION** Do not touch the components inside the switcher without being electrically grounded. Electrostatic discharge (ESD) can damage ICs, even if you cannot feel, see, or hear it.

3. On the side of the front panel board that faces the rear of the switcher, locate the RS-232 ribbon cable. The RS-422 ribbon cable receptacle, which is normally empty, is located to the left of the RS-232 ribbon cable receptacle.
4. To remove the cable from the current receptacle, press the two receptacle tabs outward as shown at the left, and pull up gently on the cable connector to remove it from the receptacle.



5. To plug the cable into the desired receptacle, align the holes in the connector with the pins in the receptacle, and press evenly until the receptacle tabs lock into place.
6. Reinstall the switcher's cover. See *Closing the switcher* above.

7. Attach the power cord to the switcher and to the AC power source. Ensure the switcher is working properly.
8. If the switcher was removed from a rack, remove its power cord, reattach the switcher to the rack, and reconnect the power cord.
9. Reconnect the input and output cables.

## Installing a firmware update

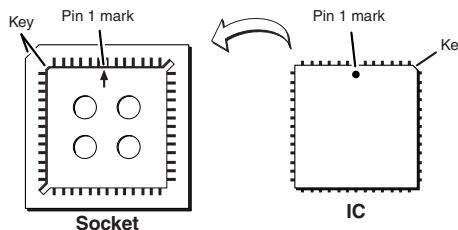
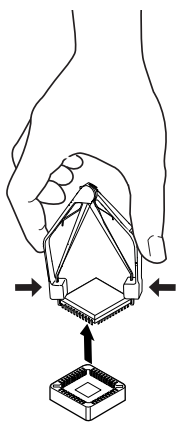
**NOTE** *The IC that contains the firmware for the matrix switcher also contains the memory in which presets and audio levels are saved. When you replace the IC, these settings will be lost. You may want to record the presets and audio levels before you replace the IC.*

To replace the firmware, do the following:

1. Follow the appropriate instructions in *Opening the Switcher* on page B-2 to gain access to the interior of your switcher, including the instructions for removing the front panel.
2. Locate the RS-232/RS-422 ribbon cable that connects the front panel board to the rear panel RS-232/422 port (figure B-3). Note which receptacle on the front panel board that the RS-232/RS-422 cable plugs into, and remove the cable from its receptacle (see step 4 in *Swapping the serial ports*).

**CAUTION** *Do not touch the components inside the switcher without being electrically grounded. Electrostatic discharge (ESD) can damage ICs, even if you cannot feel, see, or hear it.*

3. Unplug the power cable from the front panel board.
4. Place the front panel board, button side down, on a suitable workspace.
5. Locate IC U7 (figure B-3).
6. Use the PLCC IC puller to remove the existing firmware IC. Squeeze the tool to align its hooks with the slots in opposite corners of socket U7. Insert the hooks, squeeze gently, and pull the IC straight out of the socket. Set the IC aside.
7. Note the key (angled corner) of the new firmware IC and the dot on the underside that indicates pin 1 (figure B-4). Orient the IC to match the key and pin 1 (indicated by arrow) on the socket, and carefully press the IC in place.
8. Reinstall the power cable that was removed in step 3.



**Figure B-4 — Key and pin 1 mark**

9. Reinstall the RS-232/RS-422 cable removed in step 2. Ensure the RS-232/RS-422 ribbon cable is plugged back into the proper receptacle for the communications format desired (RS-232 or RS-422).

## Reference Information, cont'd

---

10. Reinstall the switcher's front panel and cover. See *Closing the switcher* on page B-4.

**WARNING** *If you choose to check for proper operation before putting the cover back on, ensure that tools and hands are outside the switcher and then perform step 11. After recognizing the new IC, the switcher should power up normally. Unplug the AC power cord, and reinstall the switcher.*

11. Reinitialize the switcher to recognize the new IC as follows:
  - a. Connect the power cord to the AC power source.
  - b. Press and **hold** the Enter button while you connect the power cord to the switcher.
  - c. Observe that the Input, Output, Preset, View, and Esc LEDs all flash.
  - d. Release the Enter button.
12. Ensure that the switcher is working properly.
13. If the switcher was removed from a rack, remove its power cord, reattach the switcher to the rack, and reconnect the power cord.
14. Reconnect the input and output cables.

### Replacing the AC fuse (CrossPoint Plus 84, 88, 124, and 128 only)

The AC fuse on the power supply board is a user-replaceable component of the CrossPoint Plus 84, 88, 124, and 128. To replace the AC fuse, do the following:

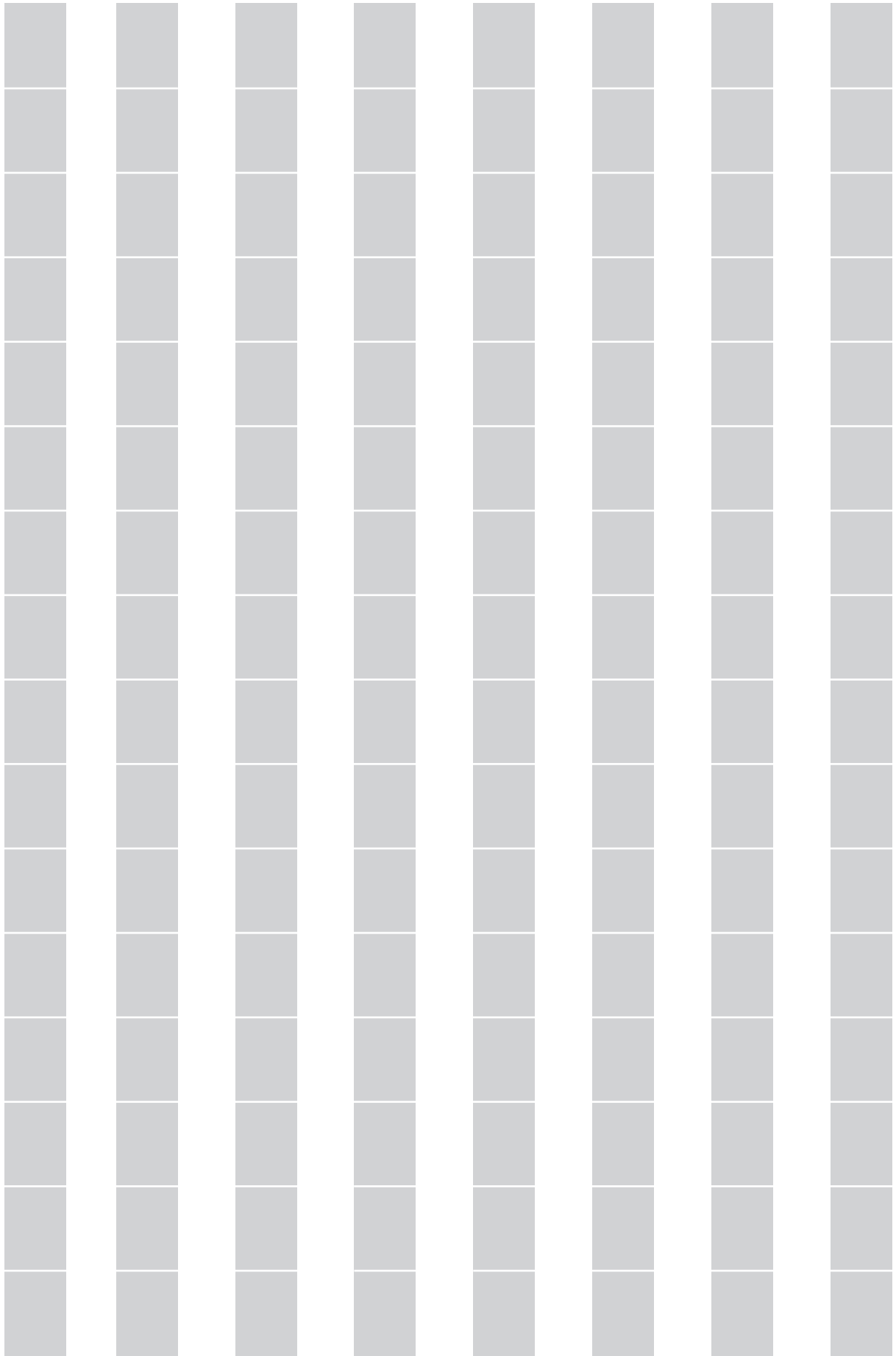
1. Follow the instructions in *Opening the CrossPoint Plus 84, 88, 124, and 128* on page B-2 to remove the top cover.
2. Locate the fuse on the power supply board (see figure B-1), and remove it from its retaining clips.
3. If test equipment is available, you can check the fuse.
4. Place a new 2A/250V fast-blow fuse in the retaining clips.
5. Reinstall the switcher's cover. See *Closing the switcher* on page B-4.

**WARNING** *If you choose to check the switcher for proper operation before putting the cover back on, ensure that tools and hands are outside the switcher, and then connect the power cord to the unit and to an AC source. The switcher should power up normally. Unplug the AC power cord, and reinstall the switcher.*

6. Attach the power cord to the switcher and to the AC power source. Make sure the switcher is working properly.
7. If the switcher was removed from a rack, remove its power cord, reattach the switcher to the rack, and reconnect the power cord.
8. Reconnect the input and output cables.

### Button Labels

Figure B-5 provides blanks of a 16-button strip of button labels. Feel free to photocopy them or cut them out of the manual, write button information in each button area as desired, and put them in the switcher's label window. For 8-button strips and 12-button strips, use scissors to trim the blank to the appropriate length.



**Figure B-5 — Button label blanks, 16-button strip**

# Reference Information, cont'd

---

## FCC Class A Notice

Note: This equipment has been tested and found to comply with the limits for a Class A digital device, pursuant to part 15 of the FCC Rules. These limits are designed to provide reasonable protection against harmful interference when the equipment is operated in a commercial environment. This equipment generates, uses and can radiate radio frequency energy and, if not installed and used in accordance with the instruction manual, may cause harmful interference to radio communications. Operation of this equipment in a residential area is likely to cause harmful interference, in which case the user will be required to correct the interference at his own expense.

Note: This unit was tested with shielded cables on the peripheral devices. Shielded cables must be used with the unit to ensure compliance.

## Extron's Warranty

Extron Electronics warrants this product against defects in materials and workmanship for a period of three years from the date of purchase. In the event of malfunction during the warranty period attributable directly to faulty workmanship and/or materials, Extron Electronics will, at its option, repair or replace said products or components, to whatever extent it shall deem necessary to restore said product to proper operating condition, provided that it is returned within the warranty period, with proof of purchase and description of malfunction to:

**USA, Canada, South America,  
and Central America:**

Extron Electronics  
1230 South Lewis Street  
Anaheim, CA 92805, USA

**Europe, Africa, and the Middle East:**

Extron Electronics, Europe  
Beeldschermweg 6C  
3821 AH Amersfoort  
The Netherlands

**Asia:**

Extron Electronics, Asia  
135 Joo Seng Road, #04-01  
PM Industrial Bldg.  
Singapore 368363

**Japan:**

Extron Electronics, Japan  
Daisan DMJ Bldg. 6F,  
3-9-1 Kudan Minami  
Chiyoda-ku, Tokyo 102-0074  
Japan

This Limited Warranty does not apply if the fault has been caused by misuse, improper handling care, electrical or mechanical abuse, abnormal operating conditions or non-Extron authorized modification to the product.

*If it has been determined that the product is defective, please call Extron and ask for an Applications Engineer at (714) 491-1500 (USA), 31.33.453.4040 (Europe), 65.6383.4400 (Asia), or 81.3.3511.7655 (Japan) to receive an RA# (Return Authorization number). This will begin the repair process as quickly as possible.*

Units must be returned insured, with shipping charges prepaid. If not insured, you assume the risk of loss or damage during shipment. Returned units must include the serial number and a description of the problem, as well as the name of the person to contact in case there are any questions.

Extron Electronics makes no further warranties either expressed or implied with respect to the product and its quality, performance, merchantability, or fitness for any particular use. In no event will Extron Electronics be liable for direct, indirect, or consequential damages resulting from any defect in this product even if Extron Electronics has been advised of such damage.

Please note that laws vary from state to state and country to country, and that some provisions of this warranty may not apply to you.



[www.extron.com](http://www.extron.com)

**Extron Electronics, USA**

1230 South Lewis Street  
Anaheim, CA 92805  
USA  
714.491.1500  
Fax 714.491.1517

**Extron Electronics, Europe**

Beeldschermweg 6C  
3821 AH Amersfoort  
The Netherlands  
+31.33.453.4040  
Fax +31.33.453.4050

**Extron Electronics, Asia**

135 Joo Seng Road, #04-01  
PM Industrial Building  
Singapore 368363  
+65.6383.4400  
Fax +65.6383.4664

**Extron Electronics, Japan**

Daisan DMJ Building 6F  
3-9-1 Kudan Minami  
Chiyoda-ku, Tokyo 102-0074 Japan  
+81.3.3511.7655  
Fax +81.3.3511.7656

## Free Manuals Download Website

<http://myh66.com>

<http://usermanuals.us>

<http://www.somanuals.com>

<http://www.4manuals.cc>

<http://www.manual-lib.com>

<http://www.404manual.com>

<http://www.luxmanual.com>

<http://aubethermostatmanual.com>

Golf course search by state

<http://golfingnear.com>

Email search by domain

<http://emailbydomain.com>

Auto manuals search

<http://auto.somanuals.com>

TV manuals search

<http://tv.somanuals.com>