

Faria[®]

**MARINE
INSTRUMENTS**



Owner's Manual

GM ALDL MG2000[™] Tachometer

ISO195

rev. A ecr#5576 8/2005

Index

Figure 1 Default screens	page 1
Description	page 1
Normal Mode	page 2
Contrast and Lighting	page 2
Displayed Functions	page 3
Default screen 1	page 3
Default screen 2	page 3
Default screen 3	page 3
Default screen 4	page 4
Figure 2 Screen Sequence	page 4
Figure 3 LCD Display Screens	page 5
Edit Mode	page 7
Functions that are adjusted in Edit Mode.	page 7
Select Default Screen	page 7
Reset Fuel Used	page 8
Set Fuel Tank Full	page 8
Set Amount of Fuel	page 9
Organize User Screens	page 9
Select Gauge Range	page 10
Select Oil Pressure Dial	page 10
Select Coolant Temp Dial	page 11
Select Voltmeter	page 11
Select Water Press Dial	page 12
Select Boost Press Dial	page 12
Select Fuel Sender	page 12
Select Oil Pressure Sender	page 13
Select Display Units	page 13
Select Pressure Units	page 13
Select Volume Units	page 14
Select Temperature Units	page 14
Select Distance Units	page 14
Select Depth Units	page 15
Select Fuel Tank Size	page 15
Select Other Fuel Tank Size	page 15
Fuel Tank Calibration	page 16
Low Fuel Alarm	page 17
Software ID and Revision	page 17
Select Self Test	page 17
Alarm Mode	page 19
Low Fuel	page 19
Engine Warnings	page 19
Alarm Messages From ECU	page 20
Alarm Clear Mode	page 21
Harness HN0390	page 22/23
Harness HN0401 GPS NMEA0183 Cable	page 24
Harness Two inch Gauge connection	page 25

This page left blank intentionally.

The FARIA MG2000 Tachometer combines the features of an ECU serial bus gateway and several instruments into one unit:

- The tachometer is analog in appearance but driven by a stepper motor for digital accuracy.
- The high resolution LCD screen displays information for many other functions and the various “screens” can be configured as the user wishes. As received, the screens are configured as shown in Fig. 1.

The MG2000 receives digital engine data from the Engine Control Unit (ECU) via the **GM ALDL** bus and can receive GPS information via a **NMEA 0183** connection to a suitable GPS unit. GPS information is displayed in the MG2000 speedometer. Analog inputs are provided for two non-engine sensors such as fuel level and oil pressure.

The MG2000 provides a Faria Bus output to allow use of various other 5, 4, and 2 inch instruments with the MG2000.

The Faria MG2000 Tachometer will turn on when the ignition key is turned on and will turn off when the ignition key is turned off. The unit will power up showing the default screen selected by the user.

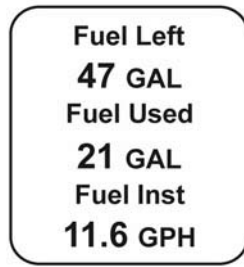
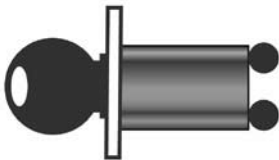

Figure 1

The instrument has three push buttons; “M” “Mode”, “Down”, and “Up”; that control the functions available. The “M” “Mode” button is used to change the function of the LCD display and to access submenus and adjustable settings. The “Down” and “Up” buttons are used to modify the settings.

Default Screens



In the “Normal” operation mode, pressing the “Mode” button and then pressing “Down” or “Up” button causes the display to cycle between the available screens

(see Figure 2). Press the “Mode” button to exit the “screen selection mode” and return to “Normal” mode or do not push any buttons for 4 seconds and the current screen will stay selected and the unit will return to “Normal” mode (see Figure 3).

In the “Normal” operation mode, press the “Mode” and “Up” buttons to change to the “Edit” menus (see Figure 3 and “Edit” mode below).



Press the “Down” or “Up” buttons to cycle between the available “Edit” functions.



Press and hold the “Down” and “Up” buttons for two (2) secs to select an “Edit” function to change. Within each “Editing” function the “Down” or “Up” buttons select settings or sub-functions. Follow the instructions in the “Edit” mode section of this manual to save the new settings after you select / adjust them.

To exit the “Edit” mode after the edit is completed, press the “Mode” button to return to “Normal” mode.



Normal Mode

When the MG2000 is turned on the unit will “beep” once, flash once and then the unit enters “Self Test” mode. The screen will display “The Self Test Mode Is In Operation” for 10 seconds.



The horn will sound three times and the warning lights and back lights will flash three times. When this is complete, the software ID and revision screen will show for two seconds, then the user selected “Default” screen will appear.

Contrast and Lighting

In the “Normal” operating mode the instrument display contrast and display mode can be adjusted by pressing the “Down” and “Up” buttons.



With the display in “Positive” mode, black on white, pressing the “Down” button decreases the contrast. Pressing the “Up” button increases contrast.

Continuing to press the “Up” button causes the display to reverse to the “Negative” mode, white on black. The contrast in this mode is controlled the same way as the “Positive” mode.

To return to “Positive” mode, continue to press the “Down” button until the display reverses.



To adjust the lighting intensity of all of the instruments in the system, press and hold both the “Down” and “Up” buttons for 2 seconds. The lighting intensity may now be adjusted by using the “Down” or “Up” buttons.



Return to the “Normal” mode by pressing and holding both the “Down” and “Up” buttons for 2 seconds.

Displayed Functions

Tachometer

The tachometer is a digital instrument with the appearance of an analog instrument. The tachometer receives data directly from the ECU so no settings are required for the dial range. A microprocessor controlled stepper motor moves the pointer to display engine revolutions per minute.

Default Screen “1”



Volts

Displays system voltage as received from the ECU (Engine Control Unit).

OIL PRESSURE

Analog input. Displays information from the analog oil pressure sender.

Default Screen “2”



Fuel Left

Displays the quantity of fuel remaining in the fuel tank based on the original quantity of fuel in the tank when full and the amount of fuel used based on the GPH from the engine ECU and the time spent at each GPH. Fuel tank size and reset are available in the “Edit” mode.

Fuel Used

Displays the amount of fuel used since reset based on the GPH from the engine ECU and the time spent at each GPH.

Fuel Inst

Displays the current, instantaneous, fuel flow in GPH.

Default Screen “3”



Engine Temp

Displays the coolant temperature received from the ECU. Dial range can be selected in the “Edit” function.

Engine Hours

Displays the Engine Hours data received from the engine ECU.

Default screen "4"



This screen displays fault conditions based on engine data received from the ECU or alarms based on internally set alarm points. Engine alarms from the ECU will be displayed as "Check Engine !"



or "Engine Emergency Stop !".



Accessing the "View" mode when the Alarm screen appears will allow more information to be displayed about the alarm if provided by the engine.

Internal alarm values can be set for "Low Fuel" and other functions. Alarms for these settings will appear as required.

LCD Display Screens:

In "Normal" mode, press "Mode" once to enter screen "Select" mode, press "Up" or "Down" to move between screens. Press "Mode" once to return to "Normal" mode.

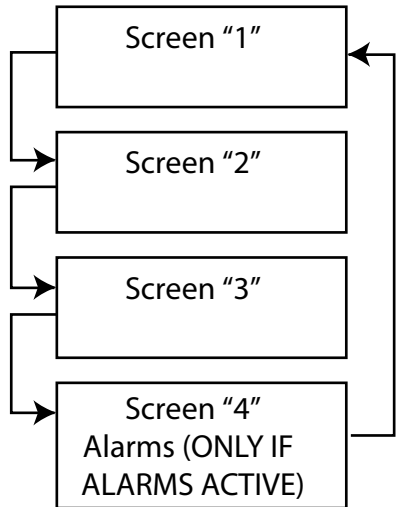

Figure 2

Figure 3 - LCD Display Screens

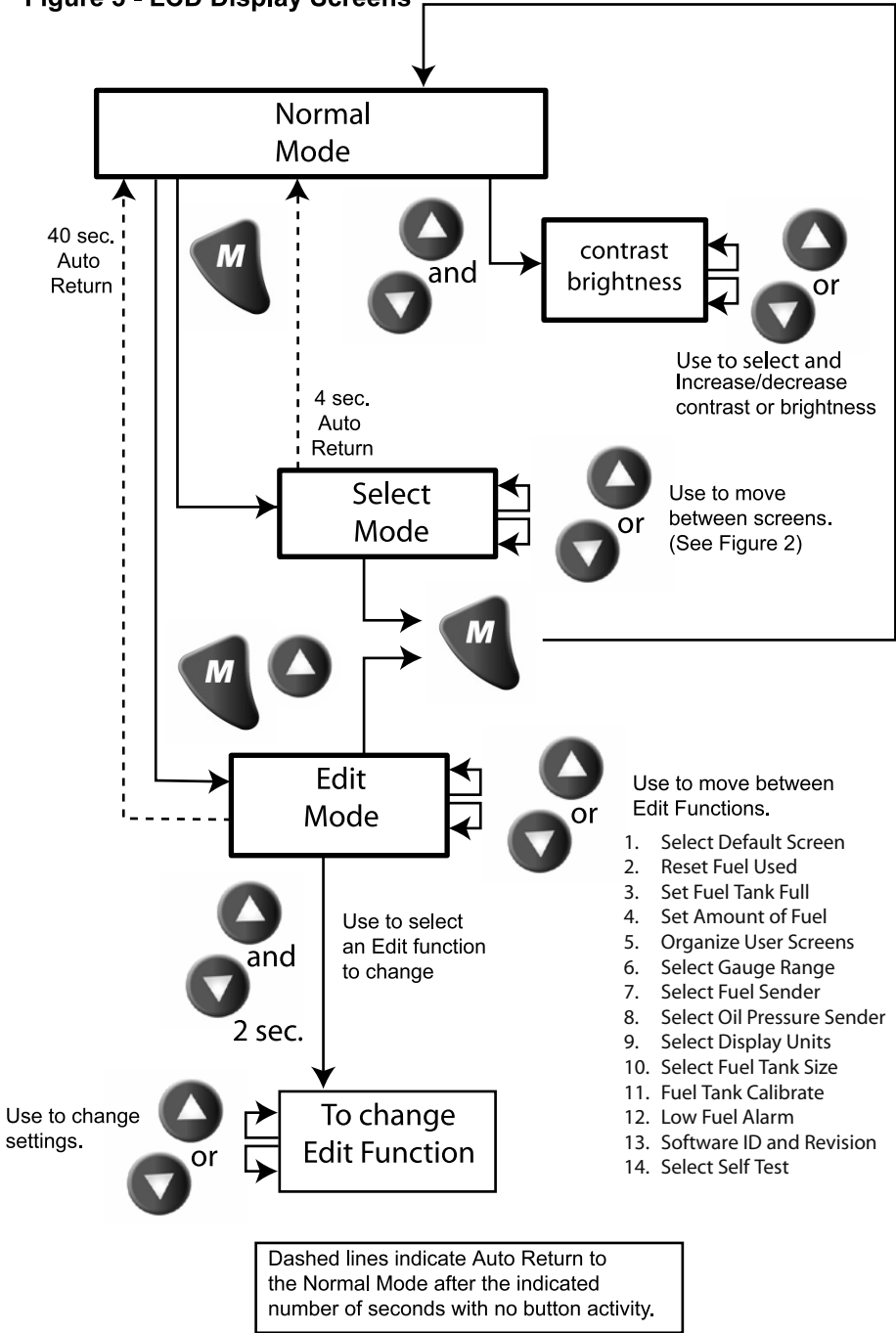

Figure 3

This page left blank intentionally.

Edit Mode

The “Edit” mode is used to adjust or set the values of numerous functions and options in the MG2000. The procedure below specifies the steps to be taken in the “Edit” mode to adjust / set each option.

To enter “Edit” mode, press the “Mode” and “Up” buttons while in “Normal” mode



To return to “Normal” mode, press “Mode” button once while in “Edit” mode.



Functions that are set or adjusted in the “Edit” mode:

1. Select Default Screen
2. Reset Fuel Used
3. Set Fuel Tank Full
4. Set Amount of Fuel
5. Organize User Screens
6. Select Gauge Range
7. Select Fuel Sender
8. Select Oil Pressure Sender
9. Select Display Units
10. Select Fuel Tank Size
11. Fuel Tank Calibrate
12. Low Fuel Alarm
13. Software ID and Revision
14. Select Self Test

Instructions – <u>Function</u>	LINE	DISPLAY
<u>Select “Default Screen.”</u>	1	Select
	2	Default
	3	Screen
Press and hold the “Up” <u>and</u> “Down” buttons for 2 seconds to select the “Default Screen.” Press “Up” or “Down” to select another function or “Mode” to return to “Normal” mode.		
(Display Screen 1 is the “Default” at first turn on.)	1	Display
	2	Screen
	3	1
Press and hold the “Up” <u>and</u> “Down” buttons for 2 seconds to select screen 1 as the “Default Screen” and exit. Press “Up” or “Down” to select another screen.		

	1	Display Next Screen
	2	
	3	
<p>Press and hold the “Up” <u>and</u> “Down” buttons for 2 seconds to select this screen as the “default screen” and exit.</p> <p>Press “Up” or “Down” to select another screen.</p> <p>Repeat until desired “Default Screen” is selected.</p>		
<p>Press “Up” or “Down” to select another function or “Mode” to return to “Normal” mode.</p>		
	1	Reset Fuel Used
<u>Reset “Fuel Used”</u>	2	
	3	
<p>Press and hold the “Up” <u>and</u> “Down” buttons for 2 seconds to reset “Fuel Used” to zero (0).</p> <p>Press “Up” or “Down” to select another function or “Mode” to return to “Normal” mode.</p>		
	1	Set Fuel Tank Full
<u>Set “Fuel Tank Full”</u>	2	
	3	
<p>NOTE: In order to use the “Fuel Left” function, the owner must set this function when the fuel tank is filled or use the set current amount of fuel below. In addition, if “Set Fuel Tank Full” function is used, the “Fuel Tank Size” must be set correctly to the size of the fuel tank in this application. The computer will monitor fuel usage and calculate the fuel left in the tank. This function does not replace the fuel level function provided by the fuel sender and should be used with caution.</p>		
<p>Press and hold the “Up” <u>and</u> “Down” buttons for 2 seconds to set “Fuel Tank Full.”</p> <p>Automatically sets the fuel available to the tank size selected by the user and returns to “Edit” mode.</p> <p>Press “Up” or “Down” to select another function or “Mode” to return to “Normal” mode.</p>		

<u>Set “Amount of Fuel”</u>	1	Set Amount Of Fuel
	2	
	3	
NOTE: If a known amount of fuel is in the fuel tank but it is not full, this function can be used to indicate the amount of fuel available. The “Fuel Left” function will then use the amount of fuel entered to calculate the “Fuel Left.”		
Press and hold the “Up” <u>and</u> “Down” buttons for 2 seconds to select “Current Amount of Fuel.”		
Press “Up” or “Down” to set the amount of fuel known to be in the fuel tank. Adjust until the displayed volume matches the known amount of fuel in the tank. When the volume is correctly set, Press and hold the “Up” <u>and</u> “Down” buttons for 2 seconds to save and exit.	1	Fuel Amount XXX G
	2	
	3	
<u>Organize User Screens</u>	1	Organize User Screens
	2	
	3	
Press and hold the “Up” <u>and</u> “Down” buttons for 2 seconds to select “Organize User Screens.” Press “Up” or “Down” to select another function or “Mode” to return to “Normal” mode.		
<u>Organize Screen 1</u>	1	Set up Screen 1
	2	
	3	
Press and hold the “Up” <u>and</u> “Down” buttons for 2 seconds to select “Organize Screen 1.” Press “Up” or “Down” to select another screen or “Mode” to return to “Edit” mode.		
Refer to the list of available functions in the owner’s manual. Press and hold “Up” or “Down” to select the number of the function to be displayed in screen 1, line 1.	1	Screen 1 Line 1 Item XX
	2	
	3	

<p>Press and hold the “Up” <u>and</u> “Down” buttons for 2 seconds to save selection for Screen 1, line 1 and advance to Screen 1, line 2.</p> <p>Press “Mode” to exit with no change made.</p>		
<p>Refer to the list of available functions in the owner’s manual. Press and hold “Up” or “Down” to select the number of the function to be displayed in screen 1, line 2.</p>	1	Screen 1
	2	Line 2
	3	Item XX
<p>Press and hold the “Up” <u>and</u> “Down” buttons for 2 seconds to save selection for Screen 1, line 2 and advance to Screen 1, line 3.</p> <p>Press “Mode” to exit with no change made.</p>		
<p>Refer to the list of available functions in the owner’s manual. Press and hold “Up” or “Down” to select the number of the function to be displayed in screen 1, line 3.</p>	1	Screen 1
	2	Line 3
	3	Item XX
<p>Press and hold the “Up” <u>and</u> “Down” buttons for 2 seconds to save selection for Screen 1, line 3 and advance to view new screen 1.</p> <p>Press “Mode” to exit with no change made.</p>		
<p>Press and hold the “Up” <u>and</u> “Down” buttons for 2 seconds to save new Screen 1.</p> <p>Press “Mode” to exit with no change made.</p>	1	Display
	2	Customer’s
	3	New screen 1
Repeat for remaining screens (2, 3, etc).		
Press “Up” or “Down” to select another function or “Mode” to return to “Normal” mode.		
<p>Select “Gauge Range” (<u>dial reading range</u>)</p>	1	Select
	2	Gauge
	3	Range
<p>Press and hold the “Up” <u>and</u> “Down” buttons for 2 seconds to select “Gauge Range.”</p> <p>Press “Up” or “Down” to select another function.</p>		
<p>Select “<u>Oil Pressure Dial</u>”</p>	1	Select
	2	Oil Pressure
	3	Dial

<p>Press and hold the “Up” <u>and</u> “Down” buttons for 2 seconds to select “Oil Pressure Dial.”</p> <p>Press “Up” or “Down” to select another “Gauge Range.”</p> <p>Press “Mode” to return to the “Edit” mode.</p>		
<p>Press “Up” or “Down” to scroll through the selections.</p> <p>When the correct choice is next to the selection arrow, Press and hold the “Up” <u>and</u> “Down” buttons for 2 seconds to save the selection and return to “Gauge Range” selection</p>	<p>1</p> <hr/> <p>2</p> <hr/> <p>3</p>	<p>> 60 psi</p> <p>80 psi</p> <p>100 psi</p>
<p><u>Select “Coolant Temperature Dial”</u></p>	<p>1</p> <hr/> <p>2</p> <hr/> <p>3</p>	<p>Select</p> <p>Coolant Temp</p> <p>Dial</p>
<p>Press and hold the “Up” <u>and</u> “Down” buttons for 2 seconds to select “Coolant Temp Dial.”</p> <p>Press “Up” or “Down” to select another “Gauge Range.”</p> <p>Press “Mode” to return to the “Edit” mode.</p>		
<p>Press “Up” or “Down” to scroll through the selections.</p> <p>When the correct choice is next to the selection arrow, Press and hold the “Up” <u>and</u> “Down” buttons for 2 seconds to save the selection and return to “Gauge Range” selection.</p>	<p>1</p> <hr/> <p>2</p> <hr/> <p>3</p>	<p>> 60 –220 f</p> <p>100 – 250 f</p>
<p><u>Select “Voltmeter Dial”</u></p>	<p>1</p> <hr/> <p>2</p> <hr/> <p>3</p>	<p>Select</p> <p>Voltmeter</p> <p>Dial</p>
<p>Press and hold the “Up” <u>and</u> “Down” buttons for 2 seconds to select “Voltmeter Dial.”</p> <p>Press “Up” or “Down” to select another “Gauge Range.”</p> <p>Press “Mode” to return to the “Edit” mode.</p>		
<p>Press “Up” or “Down” to scroll through the selections.</p> <p>When the correct choice is next to the selection arrow, Press and hold the “Up” <u>and</u> “Down” buttons for 2 seconds to save the selection and return to “Gauge Range” selection.</p>	<p>1</p> <hr/> <p>2</p> <hr/> <p>3</p>	<p>> 16 v</p> <p>32 v</p>

<u>Select “Water Press Dial”</u>	1	Select Water Press Dial
	2	
	3	
<p>Press and hold the “Up” <u>and</u> “Down” buttons for 2 seconds to select “Water Press Dial.”</p> <p>Press “Up” or “Down” to select another “Gauge Range.”</p> <p>Press “Mode” to return to the “Edit” mode.</p>		
<p>Press “Up” or “Down” to scroll through the selections.</p> <p>When the correct choice is next to the selection arrow, Press and hold the “Up” <u>and</u> “Down” buttons for 2 seconds to save the selection and return to “Gauge Range” selection.</p>	1	> 30 PSI 45 PSI 60 PSI
	2	
	3	
<u>Select “Boost Press Dial”</u>	1	Select Boost Press Dial
	2	
	3	
<p>Press and hold the “Up” <u>and</u> “Down” buttons for 2 seconds to select “Boost Press Dial.”</p> <p>Press “Up” or “Down” to select another “Gauge Range.”</p> <p>Press “Mode” to return to the “Edit” mode.</p>		
<p>Press “Up” or “Down” to scroll through the selections.</p> <p>When the correct choice is next to the selection arrow, Press and hold the “Up” <u>and</u> “Down” buttons for 2 seconds to save the selection and return to “Gauge Range” selection.</p>	1	> 20 PSI 30 PSI 50 PSI 70 PSI
	2	
	3	
	4	
<u>Select “Fuel Sender”</u>	1	Select Fuel Sender
	2	
	3	
<p>Press and hold the “Up” <u>and</u> “Down” buttons for 2 seconds to select “Fuel Sender.”</p> <p>Press “Up” or “Down” to select another function.</p>		

<p>Press “Up” or “Down” to scroll through the selections.</p> <p>When the correct choice is next to the selection arrow, Press and hold the “Up” <u>and</u> “Down” buttons for 2 seconds to save the selection and return to the “Edit” mode.</p>	1	> USA
	2	240 – 33 ohm
	3	EU
	4	10 – 180 ohm
	5	Centroid
	6	
<p>Press “Up” or “Down” to select another function or “Mode” to return to the “Normal” mode.</p>		
<p><u>Select “Oil Pressure Sender”</u></p>	1	Select
	2	Oil Pressure
	3	Sender
<p>Press and hold the “Up” <u>and</u> “Down” buttons for 2 seconds to select “Oil Pressure Sender.”</p> <p>Press “Up” or “Down” to select another function.</p>		
<p>Press “Up” or “Down” to scroll through the selections.</p> <p>When the correct choice is next to the selection arrow, Press and hold the “Up” <u>and</u> “Down” buttons for 2 seconds to save the selection and return to the “Edit” mode.</p>	1	60 PSI
	2	80 PSI
	3	100 PSI
<p>Press “Up” or “Down” to select another function or “Mode” to return to the “Normal” mode.</p>		
<p><u>Select “Display Units”</u></p>	1	Select
	2	Display
	3	Units
<p>Press and hold the “Up” and “Down” buttons for 2 seconds to select “Units.”</p> <p>Press “Up” or “Down” to select another function.</p>		
<p><u>Select “Pressure Units”</u></p>	1	Select
	2	Pressure
	3	Units
<p>Press and hold the “Up” <u>and</u> “Down” buttons for 2 seconds to select “Pressure Units.”</p> <p>Press “Up” or “Down” to select another choice of “Units.”</p>		

Press “Up” or “Down” to scroll through the selections. When the correct choice is next to the selection arrow, Press and hold the “Up” <u>and</u> “Down” buttons for 2 seconds to save the selection and return to select “Units.”	1	>	PSI BAR
	2		
	3		
<u>Select “Volume Units”</u>	1		Select Volume Units
	2		
	3		
Press and hold the “Up” <u>and</u> “Down” buttons for 2 seconds to select “volume units” Press “Up” or “Down” to select another choice of “Units”			
Press “Up” or “Down” to scroll through the selections. When the correct choice is next to the selection arrow, Press and hold the “Up” <u>and</u> “Down” buttons for 2 seconds to save the selection and return to select “Units”	1	>	GAL LITERS
	2		
	3		
<u>Select “Temperature Units”</u>	1		Select Temperature Units
	2		
	3		
Press and hold the “Up” <u>and</u> “Down” buttons for 2 seconds to select “Temperature Units.” Press “Up” or “Down” to select another choice of “Units.”			
Press “Up” or “Down” to scroll through the selections. When the correct choice is next to the selection arrow, Press and hold the “Up” <u>and</u> “Down” buttons for 2 seconds to save the selection and return to select “Units.”	1	>	F C
	2		
	3		
<u>Select “Distance Units”</u>	1		Select Distance Units
	2		
	3		
Press and hold the “Up” <u>and</u> “Down” buttons for 2 seconds to select “Distance Units.” Press “Up” or “Down” to select another choice of “Units.”			

<p>Press “Up” or “Down” to scroll through the selections.</p> <p>When the correct choice is next to the selection arrow, Press and hold the “Up” <u>and</u> “Down” buttons for 2 seconds to save the selection and return to select “Units.”</p>	1	>	Miles
	2		kM
	3		NM
<p><u>Select “Depth Units”</u></p>	1		Select
	2		Depth
	3		Units
<p>Press and hold the “Up” <u>and</u> “Down” buttons for 2 seconds to select “Depth Units”</p> <p>Press “Up” or “Down” to select another choice of “Units.”</p>			
<p>Press “Up” or “Down” to scroll through the selections.</p> <p>When the correct choice is next to the selection arrow, Press and hold the “Up” <u>and</u> “Down” buttons for 2 seconds to save the selection and return to select “Units.”</p>	1	>	Feet
	2		Meters
	3		Fathoms
<p>Press “Up” or “Down” to select another function or “Mode” to return to “Normal” mode.</p>			
<p><u>Select “Fuel Tank Size”</u></p>	1		Select
	2		Fuel Tank
	3		Size
<p>Press and hold the “Up” <u>and</u> “Down” buttons for 2 seconds to select “Fuel Tank Size”</p> <p>Press “Up” or “Down” to select another function</p>	1		Select
	2		Standard
	3		Fuel Tank
	4		Size
<p>Press “Up” or “Down” to scroll through the selections.</p> <p>When the correct choice is next to the selection arrow, Press and hold the “Up” <u>and</u> “Down” buttons for 2 seconds to save the selection and return to select “Units”</p>	1	>	25 G
	2		36 G
	3		40 G
			50 G
			55 G
			80 G
			120 G

If there is no tank size available in the list that matches your tank size, scroll to the next screen.	1	Select
	2	Other
	3	Fuel Tank
	4	Size
Press “Up” or “Down” to set the fuel tank size displayed on the screen to match your fuel tank size. Line 4 value will adjust. When set, Press and hold the “Up” <u>and</u> “Down” buttons for 2 seconds to save and exit.	1	Select
	2	Other
	3	Fuel Tank
	4	XXX G
Press “Up” or “Down” to select another function or “Mode” to return to “Normal” mode.		
<u>Select “Fuel Tank Calibration”</u>	1	Calibrate
	2	Fuel
	3	Tank
Press and hold the “Up” <u>and</u> “Down” buttons for 2 seconds to select “Fuel Tank Calibration.” Press “Up” or “Down” to select another function.		
Ensure that fuel tank is as empty as possible.	1	Calibrate
	2	Fuel Tank
	3	Empty
Press and hold the “Up” <u>and</u> “Down” buttons for 2 seconds to save “Empty” calibration and press “Down” to go to “Half” tank calibration.		
Fill fuel tank half full.	1	Calibrate
	2	Fuel Tank
	3	Half
Press and hold the “Up” <u>and</u> “Down” buttons for 2 seconds to save “1/2 tank” calibration and press “Down” to go to “Full” tank calibration.		
Fill fuel tank completely full.	1	Calibrate
	2	Fuel Tank
	3	Full

Press and hold the “Up” <u>and</u> “Down” buttons for 2 seconds to save “Full Tank” calibration and exit.		
Press “Up” or “Down” to select another function or “Mode” to return to “Normal” mode.		
<u>Select “Low Fuel Alarm” setting</u>	1	Low
	2	Fuel
	3	Alarm
Press and hold the “Up” <u>and</u> “Down” buttons for 2 seconds to select “Low Fuel Alarm.”		
Press “Up” or “Down” to select another function.		
Adjust low fuel alarm setting.	1	Low
	2	Fuel
	3	XX.X
Press “Up” or “Down” to set desired “Low Fuel Alarm” setting. Line 3 value will adjust.		
Press and hold the “Up” <u>and</u> “Down” buttons for 2 seconds to save “Low Fuel Alarm” and exit.		
Press “Up” or “Down” to select another function or “Mode” to return to “Normal” mode.		
<u>Select “Software ID and Revision”</u>	1	Software Id
	2	and
	3	Revision
	4	Minigateway
	5	- Rev -
Press “Up” or “Down” to select another function or “Mode” to return to “Normal” mode.		
<u>Select “Self Test”</u>	1	Select
	2	Self
	3	Test
Press and hold the “Up” <u>and</u> “Down” buttons for 2 seconds to select “Self Test.”		
Press “Up” or “Down” to select another function.		

<p>This screen will display for 10 seconds.</p> <p>The horn will sound three times.</p> <p>The warning lights will flash three times.</p> <p>The backlights will flash three times.</p>	1	<p>The Self Test Mode Is in Operation</p>
	2	
	3	
	4	
	5	
	6	
<p>When “Self Test” is complete the unit will return to the “Edit” mode.</p>		
<p>Press “Up” or “Down” to select another function or “Mode” to return to “Normal” mode.</p>		

Available Functions for Display in MG2000 ALDL Tachometer Screens

The functions listed below can be displayed in the user configurable screens. All of the functions may not be available in your installation. If a function is selected for display and that function does not appear on the screen, the function does not exist in this installation.

A function is selected for display by selecting “Organize User Screens” in “Edit” mode.

1. System voltage
2. Oil Pressure
3. Coolant temperature (Engine Temp)
4. Engine hours
5. Fuel remaining based on usage and tank volume when filled (Fuel Left)
6. Fuel used since last reset (Fuel Used)
7. Fuel consumption rate (Fuel Inst)

Alarm Mode

The “Alarm” screen appears only if an alarm condition exists. The alarm condition may be a warning sent from the engine ECU or a “Local” alarm such as “Low Fuel”. When an alarm condition occurs, the “Alarm Screen” will appear and the screens described below will be displayed.

alarm will re-occur after a period of time to ensure that the user remembers the alarm condition.

Once an alarm condition has been corrected, the alarm screen, horn, and warning lights will no longer be displayed.

The descriptions below also explain how to temporarily override the alarm screen and audible / visual warnings and return to “Normal” mode. In all cases, the

Alarm Mode	LINE	DISPLAY
The “Alarm” screen will appear if a local alarm or an engine alarm occurs. The local alarm is “Low Fuel”. Only two engine alarms appear automatically, “Check Engine” and “Engine Emergency Stop”. Follow the instructions provided to view more information about engine alarms.		
<p style="text-align: center;">LOW FUEL</p> Displays “Low Fuel” warning. Red LED blinks. Horn “Beeps”.	1	Low Fuel !
	2	
	3	
Press “Mode” to turn off LED, silence alarm horn, and return to “Run” mode. Alarm will reactivate in 15 minutes but can continue to be deactivated as required.		
ENGINE WARNINGS		
Any engine alarm except “Engine Emergency Stop” Red LED blinks. Horn “Beeps.”	1	CHECK ENGINE !
	2	
	3	
“Engine Emergency Stop” alarm. Red LED on continuously. Horn on continuously.	1	ENGINE EMERGENCY STOP !
	2	
	3	

Press and hold “Up” and “Down” for 2 seconds to view alarm messages.
 Press “Mode” to silence alarm horn and return to “Run” mode. LED will continue to function as stated until engine alarm(s) is no longer sent by ECU.

***Alarm Messages
 From the Engine ECU***

OVER TEMPERATURE	1	HIGH ENGINE TEMP
	2	
	3	
LOW OIL PRESSURE	1	LOW OIL PRESSURE
	2	
	3	
LOW OIL LEVEL	1	LOW OIL LEVEL
	2	
	3	
LOW FUEL PRESSURE	1	LOW FUEL PRESSURE
	2	
	3	
LOW SYSTEM VOLTAGE	1	LOW SYSTEM VOLTAGE
	2	
	3	
RPM REDUCTION	1	RPM REDUCTION SEE DEALER
	2	
	3	
RPM LIMIT EXCEEDED	1	RPM LIMIT EXCEEDED
	2	
	3	
KNOCK SENSOR	1	KNOCK SENSOR SEE DEALER
	2	
	3	
IGNITION FAULT	1	IGNITION FAULT SEE DEALER
	2	
	3	
MAGNETIC SENSOR	1	MAG SENSOR SEE DEALER
	2	
	3	

MANIFOLD AIR SENSOR	1	MAN AIR SENSOR SEE DEALER
	2	
	3	
THROTTLE POSITION SENSOR	1	TPS FAULT SEE DEALER
	2	
	3	
COOLANT SENSOR	1	COOLANT SENSOR SEE DEALER
	2	
	3	
ENGINE ECU CABLE NOT CONNECTED OR NO DATA	1	NO ENGINE FOUND
	2	
	3	
ENGINE EMERGENCY STOP	1	ENGINE EMERGENCY STOP !
	2	
	3	

Alarm Clear Mode	LINE	DISPLAY
When an alarm condition is corrected or clears, the "Alarms Clear !" screen will appear for approximately one second. The original screen will then reappear. This ensures that the operator is aware that the condition has been corrected.	1	Alarms Clear !
	2	
	3	

Harness HN0390

ALDL

Tachometer Cable

ALDL

MG2000 Tachometer

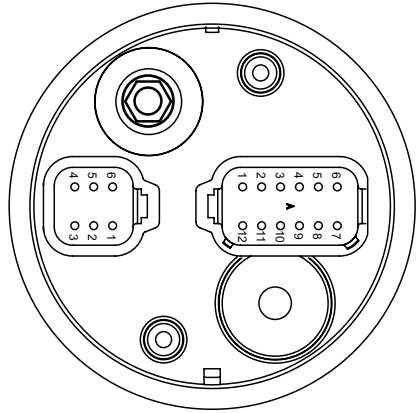

12- pin connector

Pin 1	Red
Pin 2	White
Pin 3	Green
Pin 4	Black
Pin 5	Violet
Pin 6	Pink
Pin 7	Blue/ White
Pin 8	Not Used
Pin 9	Not Used
Pin 10	Green/ Black
Pin 11	Black
Pin 12	Tan/ Blue

4- pin connector

Pin A	Red
Pin B	White
Pin C	Green
Pin D	Black & Shield

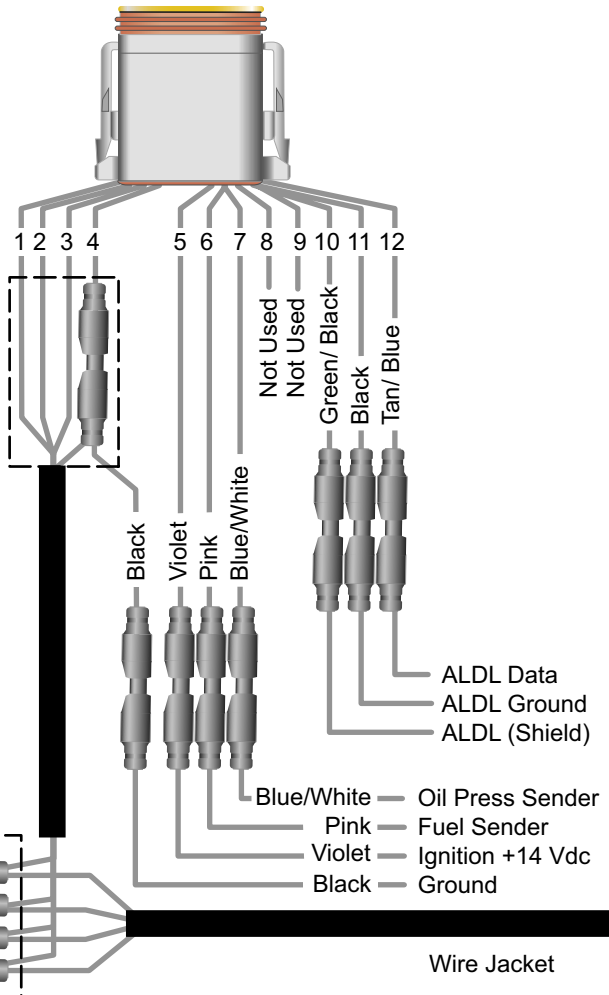
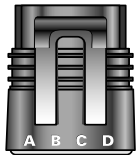

Harness HN0390 Speedometer Cable

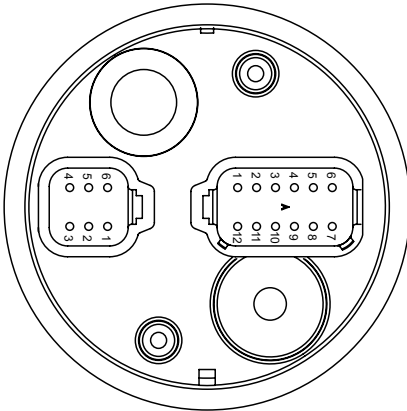

12- pin connector

Pin 1	Red
Pin 2	White
Pin 3	Green
Pin 4	Black
Pin 5	Not Used
Pin 6	Tan/ Black
Pin 7	Tan
Pin 8	Not Used
Pin 9	Not Used
Pin 10	Not Used
Pin 11	Not Used
Pin 12	Not Used

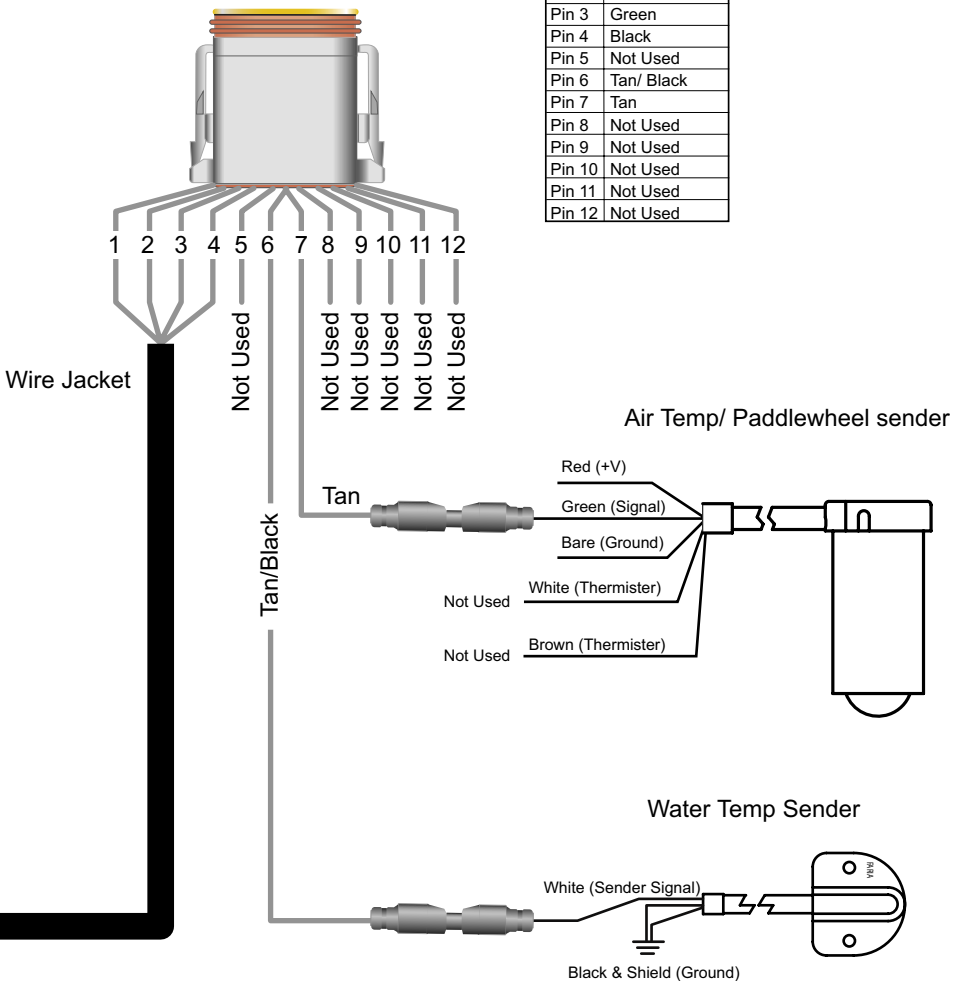

Harness HN0401

NMEA 0183 Cable

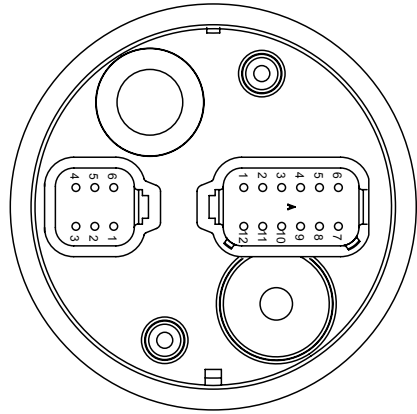

6- pin connector

Pin 1	Not Used
Pin 2	Not Used
Pin 3	Red/ White
Pin 4	Red/ Blue
Pin 5	Not Used
Pin 6	Not Used

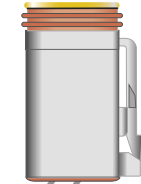

GPS100 Antenna

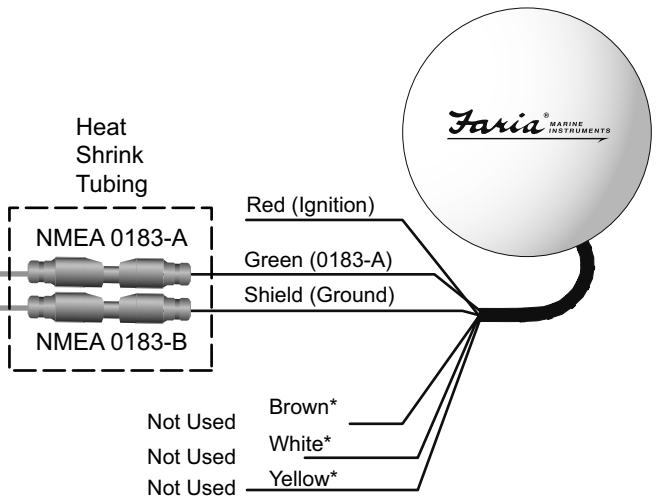

- *Note:
- 1) Cut off the connector at the end of the antenna cable
 - 2) Cut off the following wires because they are not used: White, Yellow, Brown
 - 3) Cut wires so that they are different lengths. This ensures they do not touch each other.

Tachometer to 2” Gauge Connection

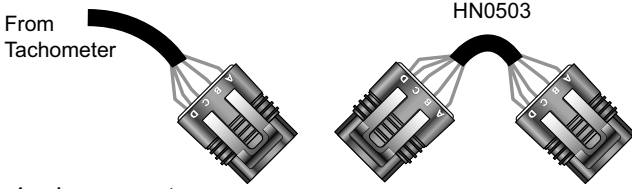

4- pin connector

Pin A	Red
Pin B	White
Pin C	Green
Pin D	Black & Shield

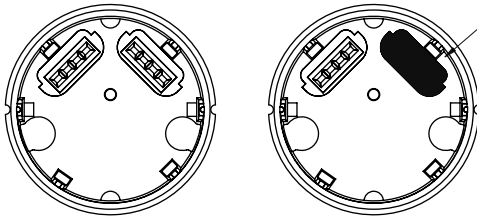

PJ0018

Note: To help reduce moisture in the gauges, be sure to install plug PJ0018 in all open connectors

2" Gauges

Notes:

Copyright 2005 by the Thomas G. Faria Corporation, Uncasville CT. All rights reserved.
No part of this publication may be reproduced in any form, in an electronic retrieval system or otherwise, without the prior written permission of the company.
Faria® is the trademark of the Thomas G. Faria Corporation

Free Manuals Download Website

<http://myh66.com>

<http://usermanuals.us>

<http://www.somanuals.com>

<http://www.4manuals.cc>

<http://www.manual-lib.com>

<http://www.404manual.com>

<http://www.luxmanual.com>

<http://aubethermostatmanual.com>

Golf course search by state

<http://golfingnear.com>

Email search by domain

<http://emailbydomain.com>

Auto manuals search

<http://auto.somanuals.com>

TV manuals search

<http://tv.somanuals.com>