



OPERATOR'S MANUAL

IS4500Z Series Zero-Turn Riding Mower



Models:

IS4500ZC28D61
IS4500ZC28D61CE
IS4500ZBL3561

Ferris Industries
5375 North Main Street
Munnsville, NY 13409
800-933-6175

23469
Revision 02
Rev. Date: 4/2005
TP 100-7174-02-45-F

Table of Contents

Safety Rules & Information	2	Troubleshooting, Adjustments & Service	26
Identification Numbers	5	Troubleshooting the Rider	26
Safety Decals	6	Troubleshooting the Mower	27
Safety Icons & Safety Interlock System	7	Seat Adjustment	28
Features & Controls	8	Ground Speed Control Lever Adjustment	28
Control Functions	8	Speed Balancing Adjustment	28
Operation	10	Neutral Position & Return Spring Adjustment	29
General	10	Neutral Adjustment	29
Checks Before Starting	10	Parking Brake Adjustment	30
Priming the Fuel System (diesel model only)	11	Mowing Height Adjustment	30
Starting the Engine	12	Deck Lift Rod Timing Adjustment	31
Stopping the Tractor and Engine	12	Deck Leveling Adjustment	32
Driving the Tractor	13	Deck Lift Spring	32
Mowing	13	Suspension Adjustment	33
Pushing the Rider by Hand	13	PTO Clutch Adjustment	34
Zero Turn Driving Practice	14	Blade Brake Check	34
Storage	16 & 17	Belt Removal & Replacement	35
Starting After Long Term Storage	16 & 17	Pump Drive Belt	35
Diesel Fuel Recommendations	16	PTO Drive Belt	36
Regular Maintenance	18	Spindle Drive Belt	36
Maintenance Schedule	18	Battery Service	38
Checking Tire Pressures	18	Checking the Battery Voltage	38
Checking/Adding Fuel (diesel model)	19	Charging A Completely	
Fuel Filter (diesel model)	19	Discharged Battery	38
Checking/Adding Fuel (gas model)	20	Jump Starting with	
Fuel Filter (gas model)	20	Auxiliary (Booster) Battery	38
Check / Add Engine Oil	21	Specifications	40
Check / Change Air Filter	21	Lawn Care & Mowing Information	LC—1
Check Hydraulic Oil Level	21		
Hydraulic Oil Filter Change	21		
Check Engine Coolant Level	22		
Change Engine Coolant	22		
Clean Radiator, Screen & Oil Cooler	22		
Lubrication	23		
Battery Maintenance	24		
Cleaning the Battery and Cables	24		
Anti-Scalp Deck Casters	24		
Servicing the Mower Blades	25		

WARNING

You must read, understand and comply with all safety and operating instructions in this manual before attempting to set-up and operate your machine.

Failure to comply with all safety and operating instructions can result in loss of machine control, serious personal injury to you and / or bystanders, and risk of equipment and property damage. The triangle in the text signifies important cautions or warnings which must be followed.

WARNING

Engine exhaust from this product contains chemicals known, in certain quantities, to cause cancer, birth defects, or other reproductive harm.



Safety Rules & Information



Read these safety rules and follow them closely. Failure to obey these rules could result in loss of control of unit, severe personal injury or death to you, or bystanders, or damage to property or equipment.

This mowing deck is capable of amputating hands and feet and throwing objects.

The triangle  in text signifies important cautions or warnings which must be followed.

TRAINING

1. Read, understand, and follow all instructions in the manual and on the unit before starting. If the operator(s) or mechanic(s) can not read English it is the owner's responsibility to explain this material to them.
2. Become familiar with the safe operation of the equipment, operator controls, and safety signs.
3. All operators and mechanics should be trained. The owner is responsible for training the users.
4. Only allow responsible adults, who are familiar with the instructions, to operate the unit.
5. Never let children or untrained people operate or service the equipment. Local regulations may restrict the age of the operator.
6. The owner/user can prevent and is responsible for accidents or injuries occurring to themselves, other people or property.
7. Data indicates that operators, age 60 years and above, are involved in a large percentage of riding mower-related injuries. These operators should evaluate their ability to operate the riding mower safely enough to protect themselves and others from serious injury.

PREPARATION

1. Evaluate the terrain to determine what accessories and attachments are needed to properly and safely perform the job. Use only accessories and attachments approved by the manufacturer.
2. Wear appropriate clothing including safety shoes, safety glasses and ear protection. Long hair, loose clothing or jewelry may get tangled in moving parts.
3. Inspect the area where the equipment is to be used and remove all objects such as rocks, toys and wire, which can be thrown by the machine.
4. Use extra care when handling gasoline and other fuels. They are flammable and vapors are explosive.
 - a) Use only an approved container.
 - b) Never remove fuel cap or add fuel with the engine running. Allow engine to cool before refueling. Do not smoke.
 - c) Never refuel or drain the machine indoors.
5. Check that operator's presence controls, safety switches and shields are attached and functioning properly. Do not operate unless they are functioning properly.

OPERATION

1. Never run an engine in an enclosed area.
2. Mow only in the daylight or with good artificial light, keeping away from holes and hidden hazards.
3. Be sure all drives are in neutral and parking brake is engaged before starting engine. Only start engine from the operator's position. Use seat belts if provided.
4. Be sure of your footing while using pedestrian controlled equipment, especially when backing up. Walk, don't run. Reduced footing could cause slipping.
5. Slow down and use extra care on hillsides. Be sure to travel in the recommended direction on hillsides. Turf conditions can affect the machines stability. Use caution when operating near drop-offs.
6. Do not mow in reverse unless absolutely necessary. Always look down and behind before and while traveling in reverse.
7. Be aware of the mower discharge direction and do not point it at anyone. Do not operate the mower without either the entire grass catcher or the deflector in place.
8. Slow down and use caution when making turns and when changing directions on slopes.
9. Never raise deck with the blades running.
10. Never leave a running unit unattended. Always disengage the PTO, set parking brake, stop engine, and remove keys before dismounting. Keep hands and feet away from the cutting units.
11. Turn off the PTO switch to disengage the blades when not mowing.
12. Never operate with guards not securely in place. Be sure all interlocks are attached, adjusted properly and functioning properly.
13. Never operate with the discharge deflector raised, removed or altered, unless using a grass catcher.
14. Do not change the engine governor setting or over-speed the engine.
15. Stop on level ground, lower implements, disengage drives, engage parking brake, shut off engine before leaving the operator's position for any reason including emptying the grass catchers or unclogging the chute.
16. Stop equipment and inspect blades after striking objects or abnormal vibration occurs. Make necessary repairs before resuming operations.
17. Keep hands and feet away from the cutting units.
18. Look behind and down before backing up to be sure of a clear path.
19. Never carry passengers and keep pets and bystanders away.
20. Do not operate the unit while under the influence of alcohol or drugs.
21. Slow down and use caution when making turns and crossing roads and sidewalks. Stop blades if not mowing.
22. Use care when loading or unloading the machine into a trailer or truck.

23. Use care when approaching blind corners, shrubs, trees or other objects that may obscure vision.
24. To reduce fire hazard, keep unit free of grass, leaves & excess oil. Do not stop or park over dry leaves, grass or combustible materials.
25. The engine in this unit is not factory equipped with a spark arrester. It is a violation of California Public Resource Code Section 4442 to use or operate the engine on or near any forest-covered, brush-covered, or grass-covered land unless the exhaust system is equipped with a spark arrester meeting any applicable local or state laws. Other states or federal area may have similar laws.
26. OSHA regulations may require the use of hearing protection when exposed to sound levels greater than 85 dBA for an 8 hour time period.

CAUTION



This machine produces sound levels in excess of 85 dBA at the operator's ear and can cause hearing loss though extended periods of exposure.

Wear hearing protection when operating this machine.

SLOPE OPERATION

Slopes are a major factor related to loss-of-control and tip-over accidents, which can result in severe injury or death. All slopes require extra caution. If you cannot back up the slope or if you feel uneasy on it, do not drive on it.

WARNING

Never operate on slopes greater than 17.6 percent (10°) which is a rise of 3-1/2 feet (106 cm) vertically in 20 feet (607 cm) horizontally.

Select slow ground speed before driving onto slope. Use extra caution when operating on slopes with rear-mounted grass catchers.

Mow across the face of slopes, not up and down, use caution when changing directions and **DO NOT START OR STOP ON SLOPE.**

Do

1. Mow across slopes, not up and down.
2. Remove obstacles such as rocks, tree limbs, etc.
3. Watch for holes, ruts, or bumps. Uneven terrain could overturn the unit. Tall grass can hide obstacles.
4. Use slow speed. Choose a slow speed so that you will not have to stop or change speed while on the slope.
5. Use extra care with grass catchers or other attachments. These can change the stability of the unit.
6. Keep all movement on the slopes slow and gradual. Do not make sudden changes in speed or direction.
7. See your authorized dealer for recommendations of available weights to improve stability.

Do Not

1. Avoid starting, stopping, or turning on a slope. If tires lose traction (i.e. machine stops forward motion on a slope), disengage the blade(s) (PTO) and drive slow off the slope.
2. Do not turn on slopes unless necessary, and then, turn slowly and gradually uphill, if possible. Never mow down slopes.
3. Do not mow near drop-offs, ditches, or embankments. The operator could lose footing or balance or mower could suddenly turn over if a wheel is over the edge of a cliff or ditch, or if an edge caves in.
4. Do not mow on wet grass. Reduced footing or traction could cause sliding.
5. Do not try to stabilize the unit by putting your foot on the ground. (ride-on units)
6. Do not mow excessively steep slopes.
7. Do not use grass catcher on steep slopes.
8. Do not mow slopes if you cannot back up them.

TOWED EQUIPMENT (RIDE-ON UNITS)

1. Tow only with a machine that has a hitch designed for towing. Do not attach towed equipment except at the hitch point.
2. Follow the manufacturer's recommendations for weight limit for towed equipment and towing on slopes. See attaching a trailer under OPERATION.
3. Never allow children or others in or on towed equipment.
4. On slopes, the weight of the towed equipment may cause loss of traction and loss of control.
5. Travel slowly and allow extra distance to stop.
6. Do not shift to neutral and coast down hill.

CHILDREN

Tragic accidents can occur if the operator is not alert to the presence of children. Children are often attracted to the unit and the mowing activity. Never assume that children will remain where you last saw them.

1. Keep children out of the mowing area and under the watchful care of another responsible adult.
2. Be alert and turn unit off if children enter the area.
3. Before and during reverse operation, look behind and down for small children.
4. Never carry children, even with the blade(s) off. They may fall off and be seriously injured or interfere with safe unit operation. Children who have been given rides in the past may suddenly appear in the mowing area for another ride and be run over or backed over by the machine.
5. Never allow children to operate the unit.
6. Use extra care when approaching blind corners, shrubs, trees, or other objects that may obscure vision.

EMISSIONS

1. Engine exhaust from this product contains chemicals known, in certain quantities, to cause cancer, birth defects, or other reproductive harm.
2. Look for the relevant Emissions Durability Period and Air Index information on the engine emissions label.

Safety Rules & Information

SERVICE AND MAINTENANCE

To avoid personal injury or property damage, use extreme care in handling gasoline. Gasoline is extremely flammable and the vapors are explosive.

Safe Handling of Gasoline

1. Extinguish all cigarettes, cigars, pipes, and other sources of ignition.
2. Use only approved gasoline containers.
3. Never remove the gas cap or add fuel with the engine running. Allow the engine to cool before refueling.
4. Never fuel the machine indoors.
5. Never store the machine or fuel container where there is an open flame, spark, or pilot light such as near a water heater or other appliance.
6. Never fill containers inside a vehicle or on a truck bed with a plastic bed liner. Always place containers on the ground away from your vehicle before filling.
7. Remove gas-powered equipment from the truck or trailer and refuel it on the ground. If this is not possible, then refuel such equipment on a trailer with a portable container, rather than from a gasoline dispenser nozzle.
8. Keep nozzle in contact with the rim of the fuel tank or container opening at all times until fueling is complete. Do not use a nozzle lock-open device.
9. If fuel is spilled on clothing, change clothing immediately.
10. Never over-fill the fuel tank. Replace gas cap and tighten securely.
11. Use extra care in handling gasoline and other fuels. They are flammable and vapors are explosive.
12. If fuel is spilled, do not attempt to start the engine but move the machine away from the area of spillage and avoid creating any source of ignition until fuel vapors have dissipated.
13. Replace all fuel tank caps and fuel container caps securely.

Maintenance and Storage

1. Always observe safe refueling and fuel handling practices when refueling the unit after transportation or storage.
2. Always follow the engine manual instructions for storage preparations before storing the unit for both short and long term periods.
3. Always follow the engine manual instructions for proper start-up procedures when returning the unit to service.
4. Never store the machine or fuel container inside where there is an open flame, such as in a water heater. Allow unit to cool before storing.
5. Shut off fuel while storing or transporting. Do not store fuel near flames or drain indoors.
6. Keep all hardware, especially blade attachment bolts, tight and keep all parts in good working condition. Replace all worn or damaged decals.
7. Never tamper with safety devices. Check their proper operation regularly.
8. Disengage drives, lower implement, set parking brake, stop engine and remove key or disconnect spark plug wire. Wait for all movement to stop before adjusting, cleaning or repairing.
9. Clean grass and debris from cutting units, drives, mufflers, and engine to prevent fires. Clean up oil or fuel spillage.

10. Let engine cool before storing and do not store near flame.
11. Stop and inspect the equipment if you strike an object. Repair, if necessary, before restarting.
12. Park machine on level ground. Never allow untrained personnel to service machine.
13. Use jack stands to support components when required.
14. Carefully release pressure from components with stored energy.
15. Disconnect battery or remove spark plug wire before making any repairs. Disconnect the negative terminal first and the positive last. Reconnect positive first and negative last.
16. Use care when checking blades. Wrap the blade(s) or wear gloves, and use caution when servicing them. Only replace blades. Never straighten or weld them.
17. Keep hands and feet away from moving parts. If possible, do not make adjustments with the engine running.
18. Charge batteries in an open well ventilated area, away from spark and flames. Unplug charger before connecting or disconnecting from battery. Wear protective clothes and use insulated tools.
19. Grass catcher components are subject to wear, damage, and deterioration, which could expose moving parts or allow objects to be thrown. Frequently check components and replace with manufacturer's recommended parts, when necessary.
20. Check brake operation frequently. Adjust and service as required.
21. Use only factory authorized replacement parts when making repairs.
22. Always comply with factory specifications on all settings and adjustments.
23. Only authorized service locations should be utilized for major service and repair requirements.
24. Never attempt to make major repairs on this unit unless you have been properly trained. Improper service procedures can result in hazardous operation, equipment damage and voiding of manufacturer's warranty.
25. Units with hydraulic pumps, hoses, or motors: **WARNING:** Hydraulic fluid escaping under pressure may have sufficient force to penetrate skin and cause serious injury. If foreign fluid is injected into the skin it must be surgically removed within a few hours by a doctor familiar with this form of injury or gangrene may result. Keep body and hands away from pin holes or nozzles that eject hydraulic fluid under high pressure. Use paper or cardboard, and not hands, to search for leaks. Make sure all hydraulic fluid connections are tight and all hydraulic hoses and lines are in good condition before applying pressure to the system. If leaks occur, have the unit serviced immediately by your authorized dealer.
26. **WARNING:** Stored energy device. Improper release of springs can result in serious personal injury. Springs should be removed by an authorized technician.
27. Models equipped with an engine radiator: **WARNING:** Stored energy device. To prevent serious bodily injury from hot coolant or steam blow-out, never attempt to remove the radiator cap while the engine is running. Stop the engine and wait until it is cool. Even then, use extreme care when removing the cap.

Identification Numbers

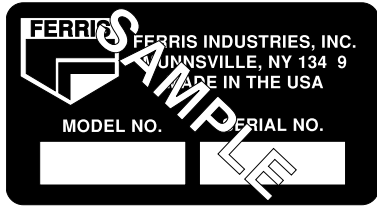

All Models

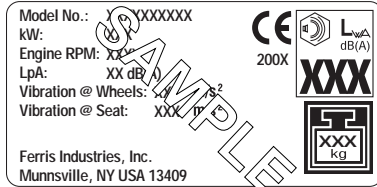

CE Models

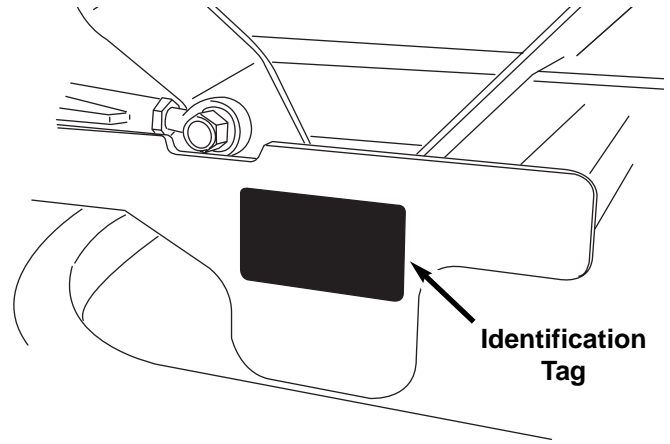

When contacting your authorized dealer for replacement parts, service, or information you **MUST** have these numbers.

Record your model/serial number and engine serial numbers on the space provided for easy access. These numbers can be found in the locations shown.

NOTE: For location of engine identification numbers, refer to the engine owner's manual.

PRODUCT REFERENCE DATA	
Unit Model Number	Unit SERIAL Number
Mower Deck Model Number	Mower Deck SERIAL Number
Dealer Name	Date Purchased
ENGINE REFERENCE DATA	
Engine Make	Engine Model
Engine Type/Spec.	Engine Code/Serial Number

CE IDENTIFICATION TAG MARKINGS

- A. Manufacturer's Identification Number
- B. Power Rating in Kilowatts
- C. Maximum Engine Speed in Rotations per Minute
- D. Sound Pressure at Operator's Position in Decibels **
- E. Vibration at the Wheels *
- F. Vibration at the Seat *
- G. Manufacturer's Address
- H. Year of Manufacture
- I. CE Compliance Logo
- J. Sound Power in Decibels ***
- K. Mass of Unit in Kilograms

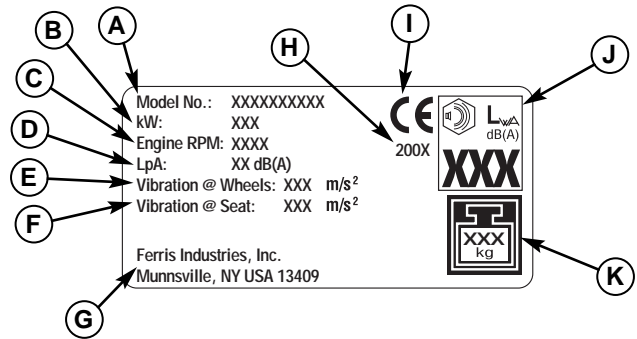

This unit complies with European Harmonized Lawn Mower Standard EN 836, European Machinery Directive 98/37/EC, and European EMC Directive 89/336/EC

* Tested according to EN 836:1997/A2:2001, EN 1032:1996, EN 1033:1995

** Tested according to EN836:1997/A2:2001

*** Tested according to 2000/14/EC

*CE Models:
Place copy of
Identification Tag here.*

Decal - Control Panel (Diesel)
Part No. 61459

Decal - Cut Height
Part No. 61458

Decal - Priming
Part No. 47696

Decal - Control Panel (Gas)
Part No. 61630

**HYDRAULIC OIL
RESERVOIR**
Use either Mobil 1™ 15W-5 Oil
OR Castrol Syntec™ 5W-5 Oil
DO NOT USE CONVENTIONAL OILS!

Decal - Hydro Oil
Part No. 45923

SAFETY ICONS

Warning: Read Operator's Manual.

Read and understand the Operator's Manual before using this machine.



Danger: Thrown Objects.

This machine is capable of throwing objects and debris. Keep bystanders away.



Warning: Remove Key Before Servicing.

Remove the key and consult technical literature before performing repairs or maintenance.



Danger: Machine Rollover.

Operating on steep slopes can cause sliding and loss of steering, control and rollover. Do not use this machine on slopes greater than 10°.



Danger: Machine Rollover.

Do not operate on any slopes when wet or slippery. Do not operate near drop-offs or near water.



Danger: Dismemberment.

This machine can amputate limbs. Keep bystanders and children away when engine is running.



Danger: Dismemberment.

This mower deck can amputate limbs. Keep hands and feet away from blades.



Danger: Dismemberment.

This machine can crush and cut. Keep hands away from belts and pulleys.



Danger: Dismemberment.

This machine can crush and cut. Keep hands away from deck lift rod.



Danger: Carbon Monoxide Poisoning.

Do not operate the engine in an unventilated area.



Danger: Fire Hazard.

Keep unit free of grass, leaves and excess oil. Do not add fuel while engine is hot or running. Stop engine and allow to cool for 5 minutes prior to adding fuel. Do not add fuel indoors, in an enclosed trailer, garage or other enclosed areas. Clean up spilled fuel. Do not smoke while operating this machine.



SAFETY INTERLOCK SYSTEM

This unit is equipped with safety interlock switches. These safety systems are present for your safety, do not attempt to bypass safety switches, and never tamper with safety devices. Check their operation regularly.

Operational SAFETY Checks

Test 1 — Engine should NOT crank if:

- PTO switch is engaged, OR
- Parking brake is not engaged, OR
- Motion control handles are not in the NEUTRAL position, OR
- Operator is not on the seat.

Test 2 — Engine SHOULD crank if:

- PTO switch is NOT engaged, AND
- Parking brake is engaged, AND
- Motion control handles are locked in the NEUTRAL position, AND
- Operator is on the seat.

Test 3 — Engine should SHUT OFF if:

- Operator rises off seat with PTO engaged, OR
- Operator rises off seat with parking brake disengaged.
- Operator moves motion control handles inward before disengaging parking brake.

Test 4 — Blade Brake Check

Mower blades and mower drive belt should come to a complete stop within seven (7) seconds after electric PTO switch is turned off (or operator rises off seat). If mower drive belt does not stop within seven (7) seconds, see your dealer.

NOTE: Once the engine has stopped, PTO switch must be turned off, parking brake must be engaged, and the motion control handles must be locked in the NEUTRAL position after the operator returns to the seat in order to start the engine.

! WARNING

If the unit does not pass a safety test, do not operate it. See your authorized dealer. Under no circumstance should you attempt to defeat the purpose of the safety interlock system.

Features & Controls

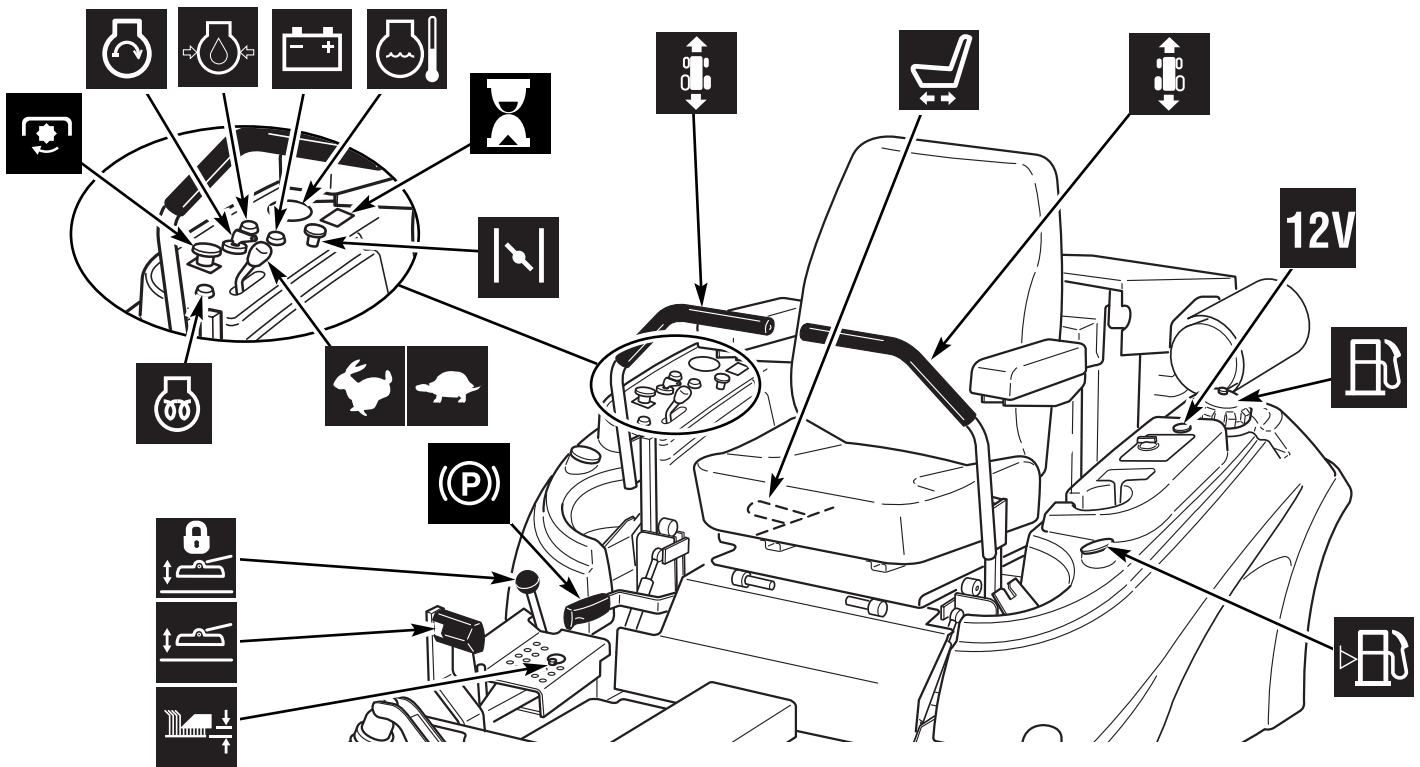

Figure 1. CONTROL FUNCTIONS

The information below briefly describes the function of the individual controls. Starting, stopping, driving, and mowing require the combined use of several controls applied in specific sequences. To learn what combination and sequence of controls to use for various tasks see the OPERATION section.

Ground Speed Levers

These levers control the ground speed of the rider. The left lever controls the left rear drive wheel and the right controls the right rear drive wheel.

Moving a lever forward increases the FORWARD speed of the associated wheel, and pulling back on a lever increases the REVERSE speed.

Note: The further a lever is moved away from the neutral position the faster the drive wheel will turn.





See the Operating the Zero Turn Rider section for steering instructions.

Seat Adjustment Lever

The seat can be adjusted forward and back. Move the lever forward, position the seat as desired, and release the lever to lock the seat in position.

Ignition Switch

The ignition switch starts and stops the engine, it has four positions:

-  Heats the glow plugs (diesel model only)
-  Stops the engine and shuts off the electrical system.
-  Allows the engine to run and powers the electrical system.
-  Cranks the engine for starting.

NOTE: Never leave the ignition switch in the ON position with the engine stopped—this drains the battery.

PTO (Power Take Off) Switch

The PTO switch engages and disengages the mower. Pull UP on the switch to engage the mower, and push DOWN to disengage the mower.

Throttle Control

Moving the throttle control fully forward is FULL throttle position. Always operate the unit at FULL throttle when mowing.

Choke (gas model only)

Close the choke for cold starting. Open the choke once the engine starts. A warm engine may not require choking. Pull the knob UP to close the choke. Push to knob DOWN to open the choke.

Parking Brake

 **DISENGAGE** Releases the parking brake.

 **ENGAGE** Locks the parking brake.

Pull the parking brake lever back to engage the parking brake. Move the lever fully forward to disengage the parking brake. *NOTE: To start the unit the parking brake must be engaged.*

Deck Lift Pedal, Cutting Height Adjustment Pin & Deck Lift Lock Lever

These control the cutting height of the mower deck. Depress the pedal until it locks into the 6" (15,2 cm) position. Place the adjustment pin in the desired cutting height and release the lift lock lever.

Hour Meter / Maintenance Reminder

Measures the time of the PTO being engaged. The hour meter measures the number of hours the PTO has been engaged. The hour meter will flash an initial oil change indicator at 5 hours, and a lubrication reminder every 50 hours. These reminders display for approximately two hours and will automatically reset themselves.

Note: The hour meter will register the passage of time only when the PTO is engaged. The hour meter has a self contained power source so the total hours are always visible.

Glow Plug Indicator (diesel model only)

Lamp that indicates that the glow plugs are heating. Hold the ignition key in the "HEAT" position until indicator lamp turns off, then turn the key to start.

Voltage Indicator

Lamp that indicates a low voltage condition.

Oil Pressure Indicator

Lamp that indicates a low oil pressure condition.

Water Temperature Gauge

Measures the engine coolant temperature.

Fuel Tank Cap

To remove the cap, turn counterclockwise.

Fuel Level Gauge

Displays the fuel level in the tank.

12V Power Outlet

Unit is equipped with a +12VDC, 20A power outlet.

Operation



GENERAL OPERATING SAFETY

Before first time operation:

- Be sure to read all information in the Safety and Operation sections before attempting to operate this tractor and mower.
- Become familiar with all of the controls and how to stop the unit.
- Drive in an open area without mowing to become accustomed to the unit.

WARNING

Never allow passengers to ride on the unit.

Before leaving the operator's position for any reason, engage the parking brake, disengage the PTO, stop the engine and remove the key.

To reduce fire hazard, keep the engine, tractor and mower free of grass, leaves and excess grease. Do not stop or park tractor over dry leaves, grass or combustible materials.

Gasoline is highly flammable and must be handled with care. Never fill the tank when the engine is still hot from recent operation. Do not allow open flame, smoking or matches in the area. Avoid over-filling and wipe up any spills.

WARNING

Do not load this zero-turn rider on a trailer or truck using two separate ramps. Only use a single ramp that is at least one foot wider than the width of the rear wheels of this rider. This rider has a zero turning radius and the rear wheels could fall off the ramps, or the rider could tip over injuring the operator or bystanders.



CHECKS BEFORE STARTING

- Check that crankcase is filled to full mark on dipstick. See the engine Operators Manual for instructions and oil recommendations.
- Check the radiator fluid level. See engine operator's manual for instructions.
- Check the hydraulic oil level. Refer to REGULAR MAINTENANCE section.
- Make sure all nuts, bolts, screws and pins are in place and tight.
- Adjust the seat position, and make certain you can reach all controls from the operators position.
- Fill the fuel tanks with fresh fuel. Refer to engine manual for fuel recommendations.

WARNING

Never operate on slopes greater than 17.6 percent (10°) which is a rise of 3-1/2 feet (106 cm) vertically in 20 feet (607 cm) horizontally.

Select slow ground speed before driving onto a slope. Use extra caution when operating on slopes with a rear-mounted grass catcher.

Mow across the face of slopes, not up and down, use caution when changing directions and DO NOT START OR STOP ON SLOPE.

PRIMING THE FUEL SYSTEM

Diesel Model Only

Priming the fuel system fills the fuel filters and removes any air bubbles from the fuel system. This must be performed before the first use, after any fuel filter maintenance or if the fuel system is run dry.

! WARNING

Fuel leaked or spilled onto hot surfaces or electrical components can cause a fire. To help prevent possible injury, turn the ignition switch off when changing fuel filter or water separator element. Clean up fuel spills immediately.

To prime the fuel system:

On the water separator:

1. Using a 1/2" wrench, loosen the vent screw (A) on the water separator 2-3 revolutions.
2. Unscrew the priming hand pump (B) located on top of the water separator. Operate the hand pump up and down until fuel that is free of air flows from the vent.
3. Tighten the vent screw (A) to 4.5 ft.lbs. (6 N.m.). DO NOT OVER TIGHTEN!

On the engine fuel filter:

1. Using a 9/16" wrench, loosen the vent screw (C) on the engine fuel filter 2-3 revolutions.
2. Operate the hand pump (B) up and down until fuel that is free of air flows from the vent.
3. Tighten the vent screw (C) to 4.5 ft.lbs. (6 N.m.). DO NOT OVER TIGHTEN!
4. Tighten the priming hand pump finger tight.
5. Start the engine. (See STARTING THE ENGINE). If the engine will not start, further priming is necessary. If the engine starts but misfires or continues to emit smoke, further priming is necessary.
6. If the engine starts but runs rough, continue to run the engine at low idle until the engine runs smoothly.

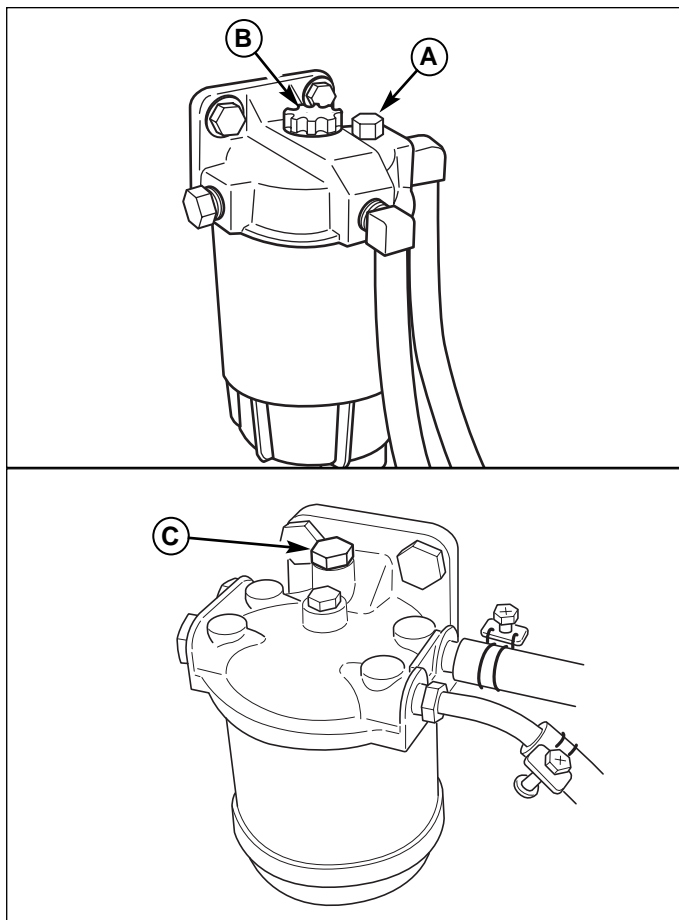

Figure 2. Fuel System Priming

- A. Water Separator Vent Screw
- B. Priming Hand Pump
- C. Engine Fuel Filter Vent Screw

WARNING

If you do not understand how a specific control functions, or have not yet thoroughly read the **FEATURES & CONTROLS** section, do so now.

Do **NOT** attempt to operate the tractor without first becoming familiar with the location and function of **ALL** controls.

STARTING THE ENGINE

(Diesel Model)

1. While sitting in the operators seat, engage the parking brake and make sure the PTO switch is disengaged and the ground speed control levers are locked in the neutral position.
2. Set the throttle to middle position (set throttle to FULL when starting in cold weather)
3. Turn the key to the HEAT position. Hold the key to turn the glow plug indicator light on and activate the glow plugs.
4. Wait until the glow plug indicator light turns off, then turn the key to START. If the engine does not start immediately, move the throttle control to FULL.

NOTE: Do not crank the engine continuously for more than 30 seconds. Allow the starter motor to cool for two minutes before cranking the engine again.

5. After the engine starts, move the engine throttle control to SLOW. Warm up the engine by running it for at least a minute.
6. Move the throttle to FULL before engaging the PTO switch or driving the machine.

In the event of an emergency the engine can be stopped by simply turning the ignition switch to STOP. Use this method only in emergency situations. For normal engine shut down follow the procedure given in STOPPING THE TRACTOR.

STARTING THE ENGINE

(Gas Model)

1. While sitting in the operators seat, engage the parking brake and make sure the PTO switch is disengaged and the motion control handles are locked in the NEUTRAL position.
2. NOTE: A warm engine may not require choking.
Set the engine throttle control to FAST throttle position. Then fully close the choke by pulling the knob OUT fully.
3. Insert the key into the ignition switch and turn it to START.
4. After the engine starts, gradually open the choke (push knob down fully). Warm up the engine by running it for at least a minute.
5. Move the throttle to FULL before engaging the PTO switch or driving the machine.

In the event of an emergency the engine can be stopped by simply turning the ignition switch to STOP. Use this method only in emergency situations. For normal engine shut down follow the procedure given in STOPPING THE RIDER.

STOPPING THE TRACTOR & ENGINE

1. Returning the ground speed control levers to the middle position will stop tractor movement. Pivot the levers outward and lock them in neutral.
2. Disengage the PTO.
3. Engage the parking brake.
4. Move the throttle control to SLOW and allow the engine to cool down for a short time.
5. Turn the ignition key to OFF. Remove the key.

DRIVING THE TRACTOR

1. Sit in the seat and adjust the seat so that you can comfortably reach all of the controls and see the instrument and gauge panels.
2. Engage the parking brake.
3. Make sure the PTO switch is disengaged and the ground speed control levers are locked in the neutral position.
4. Start the engine (see STARTING THE ENGINE).
5. Disengage the parking brake and pivot the ground speed control levers inward.
6. Move the levers evenly forward to travel forward. Return them to the neutral position to stop. Note that the further the levers are moved forward the faster the tractor will travel.
7. Stop the tractor by returning the control levers to the neutral position, pivoting the levers outward to lock into the neutral position, engaging the parking brake, and stopping the engine (see STOPPING THE TRACTOR AND ENGINE).

NOTE: See the ZERO-TURN DRIVING PRACTICE section on pages 14 & 15 for detailed instructions on driving the tractor.

MOWING

1. Engage the parking brake. Make sure the PTO switch is disengaged, the motion control handles are locked in the NEUTRAL position and the operator is on the seat.
2. Start the engine (see STARTING THE ENGINE).
3. Set the mower cutting height.
4. Set the throttle to FULL.
5. Engage the PTO by pulling up on the PTO switch.
6. Begin mowing. See the *Lawn Care Section* for tips on mowing patterns, lawn care, and trouble shooting information.
7. When finished, slow engine down and shut off the PTO.
8. Stop the engine (see STOPPING THE TRACTOR AND ENGINE).

PUSHING THE RIDER BY HAND



DO NOT TOW RIDER

Towing the unit will cause hydraulic pump and wheel motor damage. Do not use another vehicle to push or pull this unit.

1. Refer to Figure 3 for hydraulic release valve location.
2. To open the release valves, turn the right-hand release valve, which is located on engine side of the right-hand pump, counter-clockwise 2 full turns MAX. Then turn the left-hand release valve, which is located on the outer side of the left-hand pump, counter-clockwise 2 full turns MAX.
3. Disengage the parking brake. The tractor can now be pushed by hand.
4. After moving the tractor, engage the parking brake. Re-engage the pumps (drive position) by turning the release valves clockwise and tighten to 80-120 in/lbs (9-13.5 N.m.)

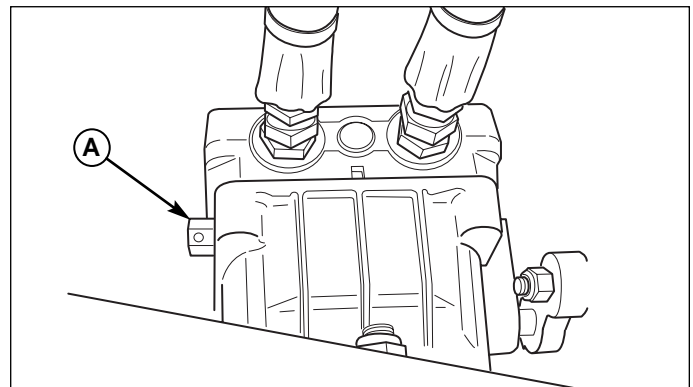

Figure 3. Hydraulic Release Valve Location

A. Hydraulic Release Valve (Right-hand side shown)

ZERO TURN DRIVING PRACTICE

The lever controls of the Zero Turn rider are responsive, and learning to gain a smooth and efficient control of the rider's forward, reverse, and turning movements will take some practice.

Spending some time going through the maneuvers shown and becoming familiar with how the unit accelerates, travels, and steers — before you begin mowing — is absolutely essential to getting the most out of the Zero Turn rider.

Locate a smooth, flat area of your lawn — one with plenty of room to maneuver. (Clear the area of objects, people and animals before you begin.) Operate the unit at mid-throttle during this practice session (ALWAYS operate at full throttle when mowing), and turn slowly to prevent tire slippage and damage to your lawn.

We suggest you begin with the Smooth Travel procedure to the right, and then advance through the forward, reverse, and turning maneuvers.

You must release the parking brake prior to moving the control levers inward.

Smooth Travel

The lever controls of the Zero Turn rider are **RESPONSIVE**.

The BEST method of handling the ground speed control levers is in three steps — as shown in Figure 4.

FIRST place your hands onto the levers as shown.

SECOND, to go forward gradually push the levers forward with your palms.

THIRD, to speed up move the levers farther forward. To slow down smoothly, slowly move the levers toward neutral.

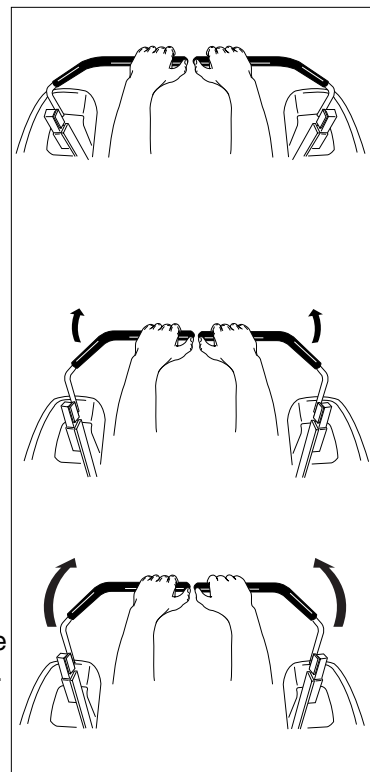

Figure 4. Move Control Levers Gradually

BASIC DRIVING

Forward Travel Practice

Gradually move both ground speed control levers — evenly FORWARD from neutral. Slow down and repeat.

NOTE: Straight forward travel takes practice. If necessary, top speed can be balance-adjusted — see the Speed Balancing Adjustment in the Adjustments section located on page 26.

Reverse Travel Practice

LOOK DOWN & BEHIND, then gradually move both ground speed control levers evenly BACK from neutral. Slow down and repeat.

NOTE: Practice backing up for several minutes before attempting to do so near objects. The rider turns sharply in reverse as well as forward, and backing up straight takes practice.

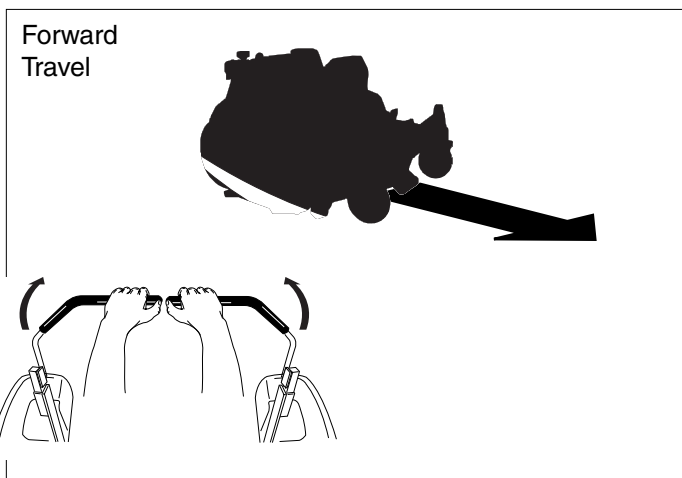

Figure 5. Forward Travel

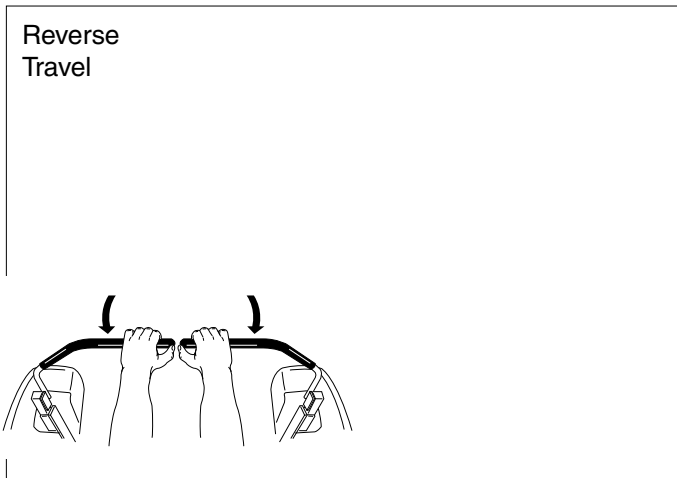

Figure 6. Reverse Travel

Practice Turning Around a Corner

While traveling forward allow one hand to pull the handlebar toward the center and return back toward neutral. Repeat several times.

NOTE: To prevent pivoting directly on the tire, it is best to keep both wheels going at least slightly.

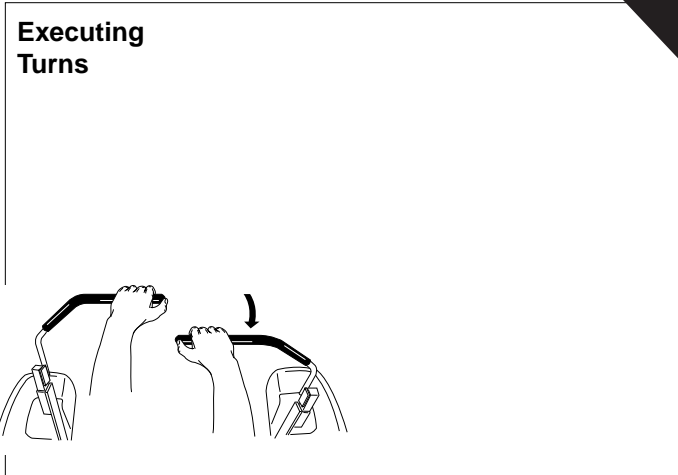

Figure 7. Turning Around a Corner

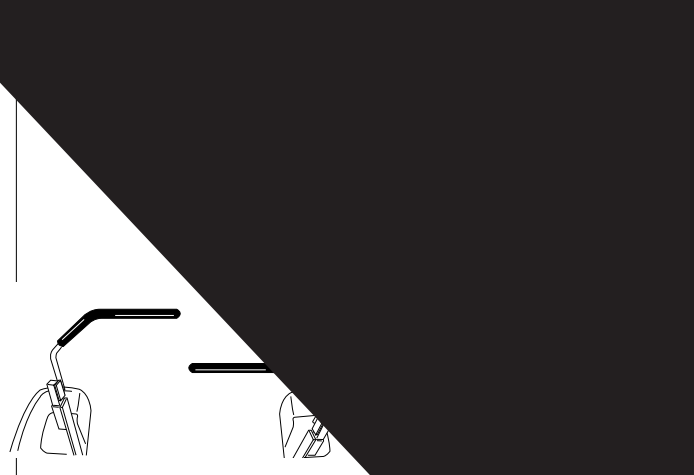

Figure 8. Turning in Place

ADVANCED DRIVING

Executing an End-Of-Row Zero Turn

Your Zero Turn Rider's unique ability to turn in place allows you to turn around at the end of a cutting row rather than having to stop and Y-turn before starting a new row.

For example, to execute a right end-of-row Zero Turn:

1. Slow down at the end of the row.
2. Move the LEFT ground speed control lever forward slightly while moving the RIGHT ground speed control lever back to center and then slightly back from center.
3. Begin mowing forward again.

This technique turns the rider RIGHT and slightly overlaps the row just cut—eliminating the need to back up and re-cut missed grass.

As you become more familiar and experienced with operating the Zero Turn rider, you will learn more maneuvers that will make your mowing time easier and more enjoyable.

Remember, the more you practice, the better your control of the Zero Turn will be!

STORAGE (Diesel Model)

Temporary Storage (30 Days Or Less)

Remember, the fuel tank will still contain some fuel, so never store the unit indoors or in any other area where fuel vapor could travel to any ignition source. Fuel vapor is also toxic if inhaled, so never store the unit in any structure used for human or animal habitation.

Here is a checklist of things to do when storing your unit temporarily or in between uses:

- Keep the unit in an area away from where children may come into contact with it. If there's any chance of unauthorized use remove the ignition key.
- If the unit can't be stored on a reasonable level surface, chock the wheels.
- Clean all grass and dirt from the mower.
- If temperature is expected to drop below 35 degrees, refer to Long Term Storage, Item 2.

Long Term Storage (Longer Than 30 Days)

Before you store your unit for the off-season, read the Maintenance and Storage instructions in the Safety Rules section, then perform the following steps:

1. Drain crankcase oil while engine is hot and refill with a grade of oil that will be required when unit is used again.
2. Use an Antifreeze tester to check the cooling system's level of protection. Read the instructions on the Antifreeze container for the appropriate ratio of water to Antifreeze for your geographical area.
3. Prepare the mower deck for storage as follows:
 - a. Remove mower deck from the unit.
 - b. Clean underside of mower deck.
 - c. Coat all bare metal surfaces with paint or light coat of oil to prevent rusting.
4. Clean external surfaces and engine.
5. Prepare engine for storage. See engine owner's manual.
6. Clean any dirt or grass from cylinder head, engine housing and air cleaner element.
7. Cover air cleaner and exhaust outlet tightly with plastic or other waterproof material to keep out moisture, dirt and insects.
8. Completely grease and oil unit as outlined in the Regular Maintenance section.
9. Clean up unit and apply paint or rust preventative to any areas where paint is chipped or damaged.
10. Be sure the battery is filled to the proper level with water and is fully charged. Battery life will be increased if it is removed, put in a cool, dry place and fully charged about once a month. If battery is left in unit, disconnect the negative cable.
11. Drain fuel system completely or add a diesel fuel stabilizer to the fuel system. If you have chosen to use a fuel stabilizer and have not drained the fuel system, follow all safety instructions and storage precautions in this manual to prevent the possibility of fire from the ignition of diesel fumes. Remember, diesel fumes can travel to distant sources of ignition and ignite, causing risk of explosion and fire.

WARNING

Never store the unit, with diesel fuel in engine or fuel tank, in a heated shelter or in enclosed, poorly ventilated enclosures. Diesel fumes may reach an open flame, spark or pilot light (such as a furnace, water heater, clothes dryer, etc.) and cause an explosion.

Handle diesel fuel carefully. It is highly flammable and careless use could result in serious fire damage to your person or property.

Drain fuel outdoors into an approved container and away from open flame or sparks.

NOTE: Diesel fuel, if permitted to stand unused for extended periods (30 days or more), may develop gummy deposits which can adversely affect the fuel pump and injector tubes and cause engine malfunction. To avoid this condition, add a diesel fuel stabilizer to the fuel tank and run the engine a few minutes, or drain all fuel from the unit before placing it in storage.

STARTING AFTER LONG TERM STORAGE

Before starting the unit after it has been stored for a long period of time, perform the following steps.

1. Remove any blocks from under the unit.
2. Install the battery if it was removed.
3. Unplug the exhaust outlet and air cleaner.
4. Fill the fuel tank with fresh fuel. See engine manual for recommendations.
5. See engine owner's manual and follow all instructions for preparing engine after storage.
6. Check crankcase oil level and add proper oil if necessary. If any condensation has developed during storage, drain crankcase oil and refill.
7. Inflate tires to proper pressure. Check fluid levels.
8. Start the engine and let it run slowly. DO NOT run at high speed immediately after starting. Be sure to run engine only outdoors or in well ventilated area.

DIESEL FUEL RECOMMENDATIONS

Fuel companies provide fuel tailored to meet the existing weather conditions. These fuels change at the start of the predominant season according to regional weather trends.

Winter fuels are tailored to give ease of starting for cold weather. Summer fuel may be somewhat heavier than winter fuel resulting in slightly better fuel economy and power. Spring and fall fuel is an average blend between winter and summer blend.

For these reasons an effort should be made to purchase fuels in such quantities that they are not carried over into the next season. Using the wrong blend of fuel can cause problems with the engine.

Refer to the engine manufacturer's manual for specific fuel recommendations.

STORAGE (Gas Model)

Temporary Storage (30 Days Or Less)

Remember, the fuel tank will still contain some gasoline, so never store the unit indoors or in any other area where fuel vapor could travel to any ignition source. Fuel vapor is also toxic if inhaled, so never store the unit in any structure used for human or animal habitation.

Here is a checklist of things to do when storing your unit temporarily or in between uses:

- Keep the unit in an area away from where children may come into contact with it. If there's any chance of unauthorized use, remove the spark plug (s) and put in a safe place. Be sure the spark plug opening is protected from foreign objects with a suitable cover.
- If the unit can't be stored on a reasonable level surface, chock the wheels.
- Clean all grass and dirt from the mower.
- If temperature is expected to drop below 35 degrees, refer to Long Term Storage, Item 2.

Long Term Storage (Longer Than 30 Days)

Before you store your unit for the off-season, read the Maintenance and Storage instructions in the Safety Rules section, then perform the following steps:

1. Drain crankcase oil while engine is hot and refill with a grade of oil that will be required when unit is used again.
2. Use an Antifreeze tester to check the cooling system's level of protection. Read the instructions on the Antifreeze container for the appropriate ratio of water to Antifreeze for your geographical area.
3. Prepare the mower deck for storage as follows:
 - a. Remove mower deck from the unit.
 - b. Clean underside of mower deck.
 - c. Coat all bare metal surfaces with paint or light coat of oil to prevent rusting.
4. Clean external surfaces and engine.
5. Prepare engine for storage. See engine owner's manual.
6. Clean any dirt or grass from cylinder head cooling fins, engine housing and air cleaner element.
7. Cover air cleaner and exhaust outlet tightly with plastic or other waterproof material to keep out moisture, dirt and insects.
8. Completely grease and oil unit as outlined in the Regular Maintenance section.
9. Clean up unit and apply paint or rust preventative to any areas where paint is chipped or damaged.
10. Be sure the battery is filled to the proper level with water and is fully charged. Battery life will be increased if it is removed, put in a cool, dry place and fully charged about once a month. If battery is left in unit, disconnect the negative cable.
11. Drain fuel system completely or add a gasoline stabilizer to the fuel system. If you have chosen to use a fuel stabilizer and have not drained the fuel system, follow all safety instructions and storage precautions in this manual to prevent the possibility of fire from the ignition of gasoline fumes. Remember, gasoline fumes can travel to distant sources of ignition and ignite, causing risk of explosion and fire.

WARNING

Never store the unit, with gasoline in engine or fuel tank, in a heated shelter or in enclosed, poorly ventilated enclosures. Gasoline fumes may reach an open flame, spark or pilot light (such as a furnace, water heater, clothes dryer, etc.) and cause an explosion.

Handle gasoline carefully. It is highly flammable and careless use could result in serious fire damage to your person or property.

Drain fuel outdoors into an approved container and away from open flame or sparks.

NOTE: Gasoline, if permitted to stand unused for extended periods (30 days or more), may develop gummy deposits which can adversely affect the engine carburetor and cause engine malfunction. To avoid this condition, add a gasoline stabilizer to the fuel tank and run the engine a few minutes, or drain all fuel from the unit before placing it in storage.

STARTING AFTER LONG TERM STORAGE

Before starting the unit after it has been stored for a long period of time, perform the following steps.

1. Remove any blocks from under the unit.
2. Install the battery if it was removed.
3. Unplug the exhaust outlet and air cleaner.
4. Fill the fuel tank with fresh gasoline. See engine manual for recommendations.
5. See engine owner's manual and follow all instructions for preparing engine after storage.
6. Check crankcase oil level and add proper oil if necessary. If any condensation has developed during storage, drain crankcase oil and refill.
7. Inflate tires to proper pressure.
8. Start the engine and let it run slowly. DO NOT run at high speed immediately after starting. Be sure to run engine only outdoors or in well ventilated area

Regular Maintenance



MAINTENANCE SCHEDULE & PROCEDURES

The following schedule should be followed for normal care of your rider and mower. You will need to keep a record of your operating time. Determining operating time is easily accomplished by observing the hour meter.

	See Page	Before First Use	Before Each Use	Every 5 Hours	Every 25 Hours	Every 100 Hours	Spring & Fall
SAFETY ITEMS							
Check Safety Interlock System	7	●					●
Check Rider Brakes	30	●					●
Check Mower Blade Stopping Time	34	●				●	
NORMAL CARE ITEMS							
Check Rider/Mower for loose hardware	—		●	●			
Check Engine Oil Level	21*	●	●	●			●
Check Engine Air Filter	21*		●			***●	
Change Engine Oil & Filter **	21*				***●		***●
Check / Adjust PTO Clutch	34					****●	
Lubricate Rider & Mower	23					***●	
Check Tire Pressure	19	●			●		
Check Hydraulic Fluid	21	●				***●	
Check Fuel Filter/Drain Water Separator	19*				●		
Clean Battery & Cables	24					●	
Clean & Sharpen Mower Blades	25					●	
Check Coolant Level	22*	●	●				
Change Coolant	22*						●
Check & Clean Radiator Screens	22*	●	●				●

* See the engine manufacturer's owner's manual.

** Change original engine oil after first 5 hours of operation.

*** More often in hot (over 85° F: 30° C) weather or dusty operating conditions.

**** Service after the first 25 hours, then after every 100 hours.

CHECK TIRE PRESSURES

Tire Pressure should be checked periodically, and maintained at the levels shown in the chart. Note that these pressures may differ slightly from the "Max Inflation" stamped on the side-wall of the tires. The pressures shown provide proper traction, improve cut quality, and extend tire life.

Tire	Pressure
Front	25 psi (1,72 bar)
Rear	18 psi (1,24 bar)

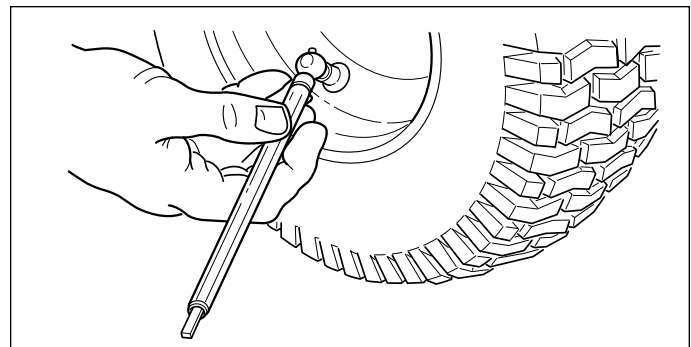

Figure 10. Checking Tire Pressure

CHECKING / ADDING FUEL (Diesel)

To add fuel:

1. Remove the fuel cap (A, Figure 11).
2. Fill the tank to the bottom of the fill tube. This will leave room in the tank for fuel expansion. Refer to your engine manual for specific fuel recommendations.
3. Install and hand tighten the fuel cap.
4. Repeat same process for opposite tank.

NOTE: The fuel tanks are tied together through a "tee" in the supply lines. By filling only one tank, the level will balance between the two tanks, effectively having 1/2 tank of fuel for each side. The fuel transfer through the "tee" is slow, so it is recommended that both tanks have fuel added to them.

FUEL FILTER

This unit is equipped with two fuel filters. One is a water separator/filter mounted to the frame, under the seat and the other is located on the engine. The water separator should be drained every 25 hours or whenever water is visible in the bowl. Replace the fuel filters every 500 hours of operation or as required.

To drain the fuel filter:

1. Turn the engine off, set the parking brake, remove the ignition key, and wait for all moving parts to stop.
2. Allow the engine to cool for five (5) minutes before draining the fuel filter.
3. Place a container under the drain valve (A, Figure 12) and turn the drain valve approximately 1-2 turns.
4. Allow the filter to drain until all water and debris have drained out.
5. Turn the drain valve to close it when finished draining.

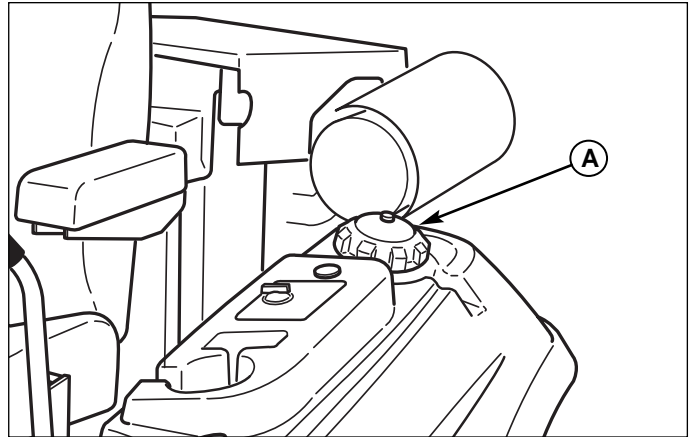

Figure 11. Fuel Tank Fill

A. Fuel Tank Cap

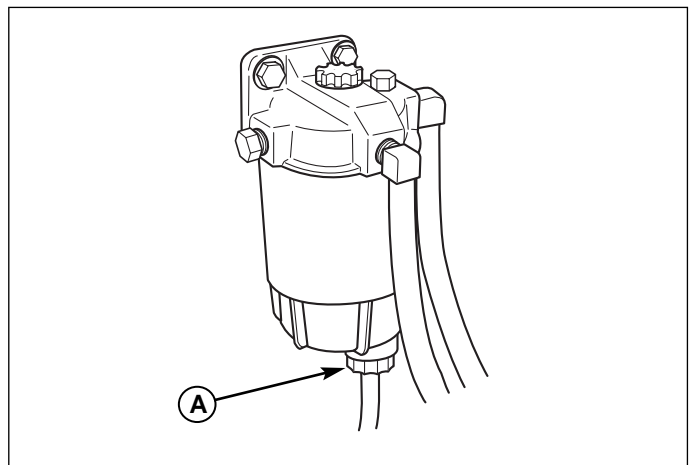

Figure 12. Drain Fuel Filter

A. Drain Valve



Do not use Kerosene in place of diesel fuel. Kerosene will damage the engine.

Consult the engine manufacturer's manual for specific fuel recommendations.

WARNING

Diesel fuel is highly flammable and must be handled with care. Never fill the tank when the engine is still hot from recent operation. Do not allow open flame, smoking or matches in the area. Avoid over-filling and wipe up any spills.

Do not drain or replace fuel filter when engine is hot, as spilled fuel may ignite. Make sure the filter drain valve is fully closed before returning the unit to service.

WARNING

Fuel leaked or spilled onto hot surfaces or electrical components can cause a fire. To help prevent possible injury, turn the ignition switch off when changing fuel filters or water separator elements. Clean up fuel spills immediately.



The water separator is under suction during normal engine operation. Ensure the drain valve is tightened securely to help prevent air from entering the fuel system.

Regular Maintenance

CHECKING / ADDING FUEL (Gas)

To add fuel:

1. Remove the fuel cap (see A, Figure 11).
2. Fill the tank to the bottom of the filler neck. This will allow for fuel expansion.

NOTE: Do not overfill. Refer to your engine manual for specific fuel recommendations.

3. Install and hand tighten the fuel cap.
4. Repeat same process for opposite tank.

NOTE: The fuel tanks are tied together through a "tee" in the supply lines. By filling only one tank, the level will balance between the two tanks, effectively having 1/2 tank of fuel for each side.

FUEL FILTER

The fuel filter is located in the fuel line between fuel shut off valve and fuel pump, behind the hydraulic reservoir. If filter is dirty or clogged, replace as follows:

1. Shut off the fuel tank selection valve.
2. Disconnect the negative battery cable.
3. Place a container below the filter to catch spilled fuel.
4. Using a pliers, open and slide hose clamps from fuel filter.
5. Remove hoses from filter.
6. Install new filter in proper flow direction in fuel line.
7. Secure with hose clamps.
8. Reconnect the negative battery cable when finished.

WARNING

Gasoline is highly flammable and must be handled with care. Never fill the tank when the engine is still hot from recent operation. Do not allow open flame, smoking or matches in the area. Avoid over-filling and wipe up any spills.

Do not remove fuel filter when engine is hot, as spilled gasoline may ignite. DO NOT spread hose clamps further than necessary. Ensure clamps grip hoses firmly over filter after installation.



Do not use gasoline containing METHANOL, gasohol containing more than 10% ethanol, gasoline additives, premium gasoline, or white gas because engine/fuel system damage could result.

CHECK / ADD ENGINE OIL

Refer to Figure 13 for dipstick and oil fill locations.

Refer to the engine owners manual for specific engine oil check and fill procedures. Also refer to the engine owners manual for specific engine oil and filter change procedures.

CHECK / CHANGE AIR FILTER

Refer to the engine owners manual for specific air filter service procedures.

CHECK HYDRAULIC OIL LEVEL

NOTE: Do not open the hydraulic oil reservoir unless oil is being added.

1. Visually check that the hydraulic oil level is filled to the recess area (A, Figure 14) of the hydraulic oil reservoir.
2. If necessary, remove the reservoir cap (B) and add either Mobil 1™, 15W-50 synthetic oil or Castrol Syntec™ 5W-50 oil. **DO NOT** use conventional oils. Make sure area around the filler neck is free of dust, dirt, or other debris.

HYDRAULIC OIL FILTER CHANGE

Change Interval: Every 500 Hours

Filter Part Number: 21357

NOTE: Removing the oil filter from the filter base will drain the oil reservoir. Have a suitable container ready to catch any spilled oil. Ferris recommends this be a dealer-only service item.

1. Locate the hydraulic oil filter (A, Figure 15) behind the oil reservoir.
2. Fill the new filter with oil. Lubricate the new filter seal with a few drops of oil.
3. Remove the oil filter and quickly thread the new filter onto the filter base until the gasket makes contact, then tighten 3/4 of a turn more.
4. Refill reservoir with fresh oil to replace any oil lost during filter change.
5. Raise the rear of the unit and secure with jackstands. Chock the front wheels to prevent the unit from rolling. Run the unit for several minutes to purge any air from the hydraulic system and check the hydraulic oil level.

IMPORTANT NOTE: Use caution after changing the filter; air in the hydraulic system may affect the responsiveness of the control levers. Repeat step 5 until the air is out of the system.

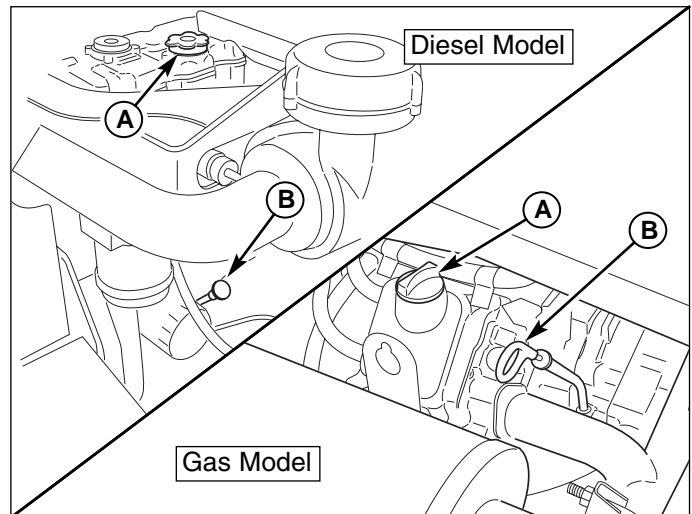

Figure 13. Change Oil & Filter

- A. Oil Fill Cap
- B. Crankcase Dip Stick

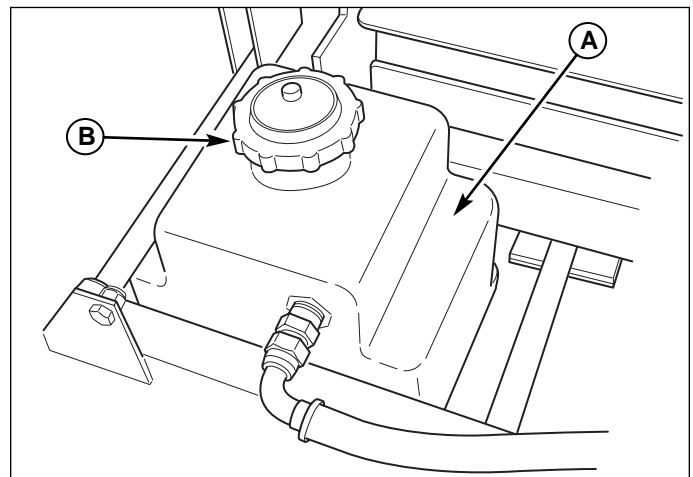

Figure 14. Hydraulic Oil Reservoir

- A. Tank Recess ("FULL" level)
- B. Cap

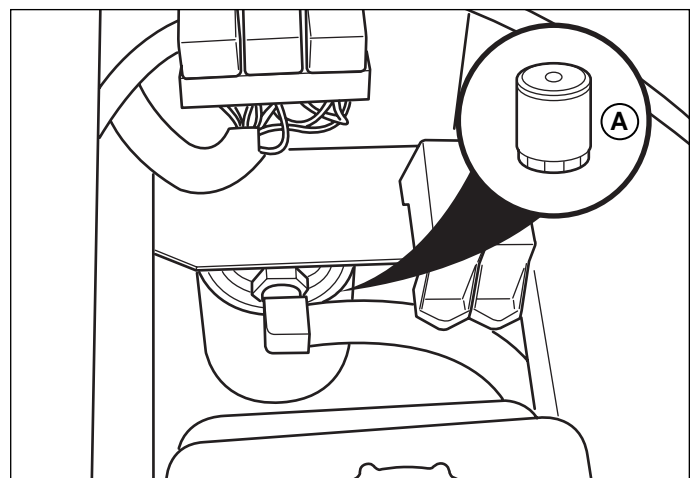

Figure 15. Hydraulic Oil Filter Location

- A. Oil Filter

Regular Maintenance

CHECK ENGINE COOLANT LEVEL

The engine coolant level and quality should be checked before each use, when the engine is cool and off.

1. Remove the radiator pressure cap (A, Figure 16) to check the fluid level.
2. Coolant level should be 1/2" (13mm) below the bottom of the filler tube. If coolant level is low, add coolant until level is 1/2" (13mm) below the bottom of the filler tube. Proper coolant mix is a 50/50 mixture of ethylene glycol and distilled water. See engine owners manual for engine coolant specifications.
3. Check the coolant level in the radiator expansion tank (Figure 17). If coolant level is low, remove the cap add coolant until level is at the "FULL" line. Proper coolant mix is a 50/50 mixture of ethylene glycol and distilled water. See engine owners manual for engine coolant specifications.

CHANGE ENGINE COOLANT

See engine owners manual for specific engine coolant procedures. The drain valve is located at the base of the right-hand side of the radiator.

CLEAN RADIATOR, SCREEN & OIL COOLER

Clean the radiator, screen and oil cooler fins before each use, or as required (depending on conditions) to allow proper air-flow through radiator and hydraulic oil cooler.

1. Raise the seat plate.
2. Lift the radiator screen straight up to remove the screen. Flush the screen with water or blow clean with air. Flush the radiator core with water or blow clean with air. See engine owners manual for proper radiator cleaning procedures.
3. Clean all dirt, grass, and debris from the oil cooler fins.
4. Reinstall the radiator screen. Make sure the screen is fully seated in the carrier.
5. Lower the seat plate.

WARNING

PRESSURIZED SYSTEM

Hot coolant can cause serious burns. To open the cooling system filler cap, stop the engine and wait until the cooling system components are cool. Loosen the cooling system pressure cap slowly in order to relieve the pressure.

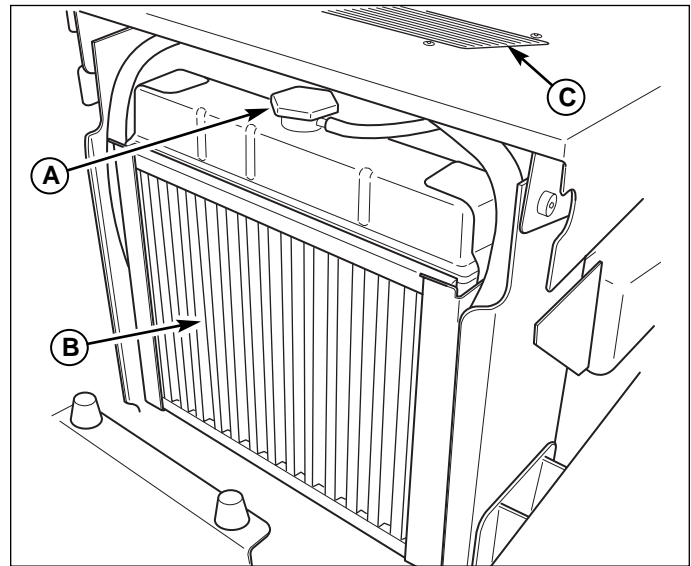

Figure 16. Radiator & Oil Cooler

(Diesel model shown)

- A. Radiator Pressure Cap
- B. Radiator Screen
- C. Hydraulic Oil Cooler

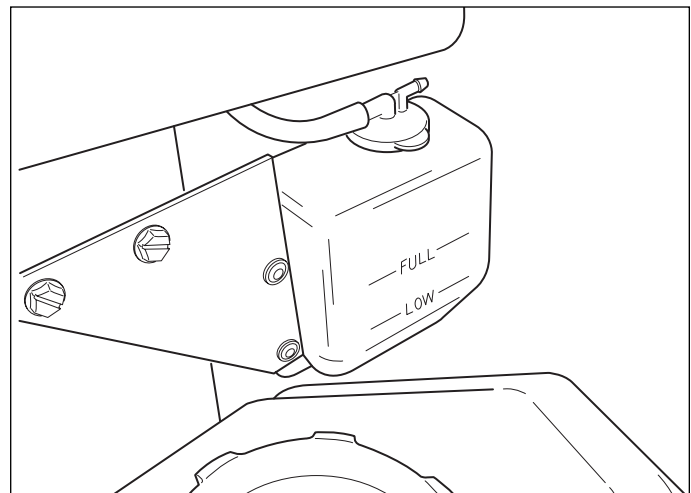

Figure 17. Radiator Expansion Tank

LUBRICATION

Lubricate the unit at the locations shown in Figure 18 through 23.

Grease: 

Use grease fittings when present. Disassemble parts to apply grease to moving parts when grease fittings are not installed.

Not all greases are compatible. Ferris Red Grease (P/N 22285) is recommended, automotive-type high-temperature, lithium grease may be used when this is not available.

Oil: 

Generally, all moving metal parts should be oiled where contact is made with other parts. Keep oil and grease off belts and pulleys. Remember to wipe fittings and surfaces clean both before and after lubrication.

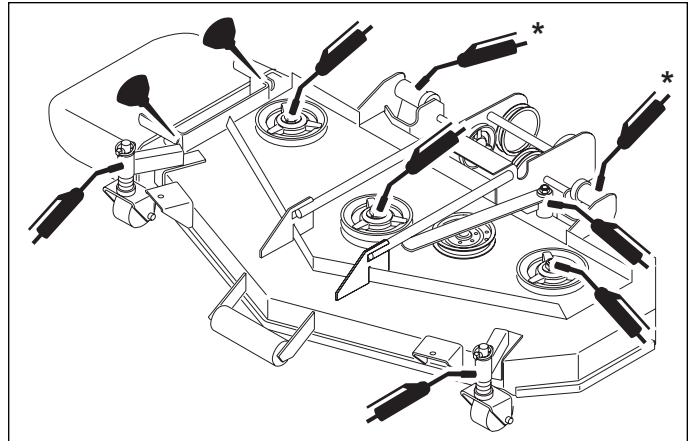

Figure 20. Deck Lubrication

* - Use needle nozzle (later models)

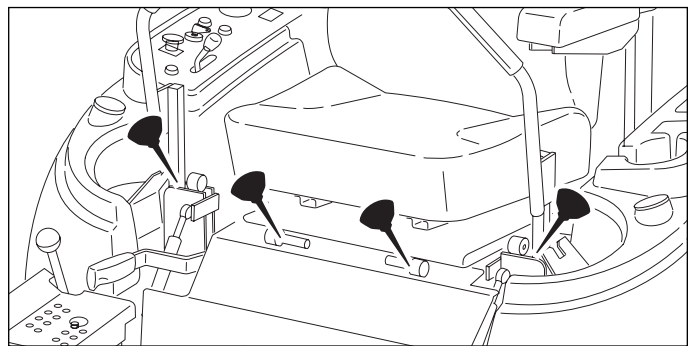

Figure 21. Control Handle Pivots & Seat Pivots

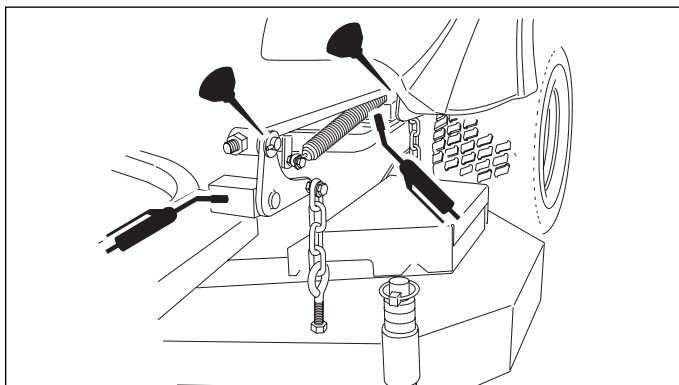

Figure 18. Deck Lift Pivots

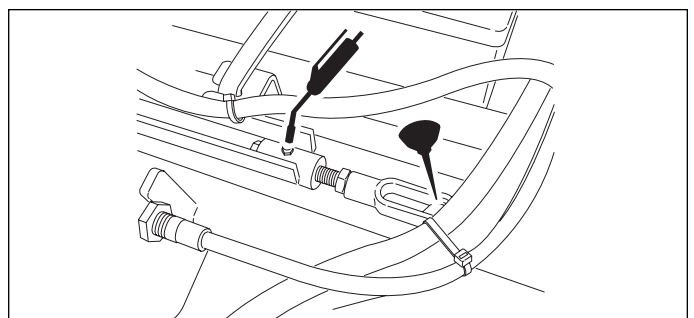

Figure 22. Center Lift Link

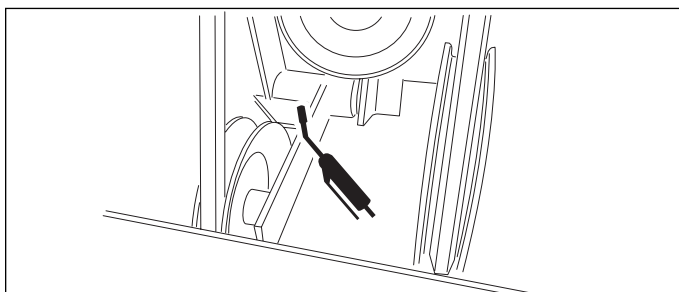

Figure 19. Mule Drive Idler Arm

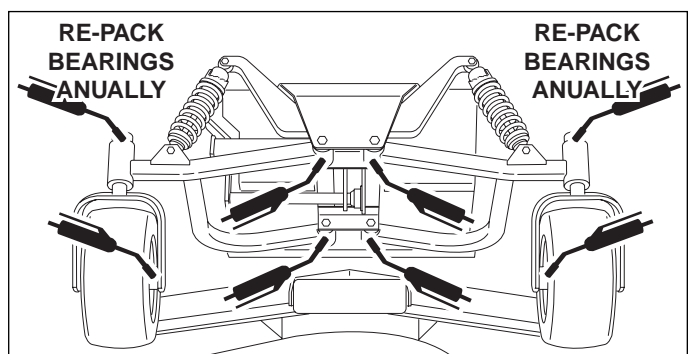

Figure 23. Casters, Wheels & Suspension Arms

Regular Maintenance

BATTERY MAINTENANCE

NOTE: This unit is equipped with a maintenance-free BCI58 battery)

Cleaning the Battery and Cables

1. Disconnect the cables from the battery, negative cable first (A, Figure 24).
2. Remove the battery retainer strap (C).
3. Remove the battery and clean the tray and surrounding areas with a solution of baking soda and water.
4. Clean the battery terminals and cable ends with a wire brush until shiny.
5. Reinstall the battery and reattach the battery cables, positive cable first (B).
6. Secure the battery with the retainer strap (C).
7. Coat the cable ends and battery terminals with petroleum jelly or non-conducting grease.

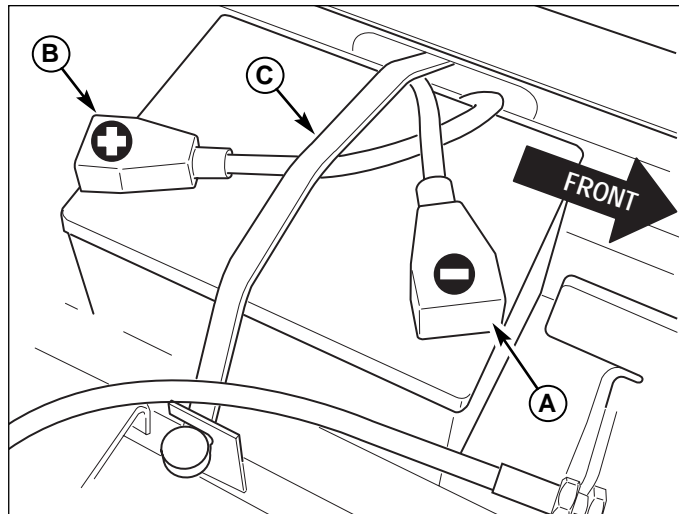

Figure 24. Battery Compartment

- A. Negative (-) Cable & Terminal
- B. Positive (+) Cable & Terminal
- C. Retainer Strap

! WARNING

Be careful when handling the battery. Avoid spilling electrolyte. Keep flames and sparks away from the battery.

When removing or installing battery cables, disconnect the negative cable FIRST and reconnect it LAST. If not done in this order, the positive terminal can be shorted to the frame by a tool.

ANTI-SCALP DECK CASTERS

The anti-scalp deck casters (A, Figure 25) will aid in preventing the mower deck from scalping or gouging the turf while mowing or turning.

The casters can be adjusted in 1/2" (1,3 cm) increments with the spacers (B). The desired position is just below the leading edge of the deck.

IMPORTANT NOTE: These casters are not intended to be in contact with the ground at all times. If you are mowing at a low cut height, adjust the casters up to prevent the casters from carrying the weight of the deck.

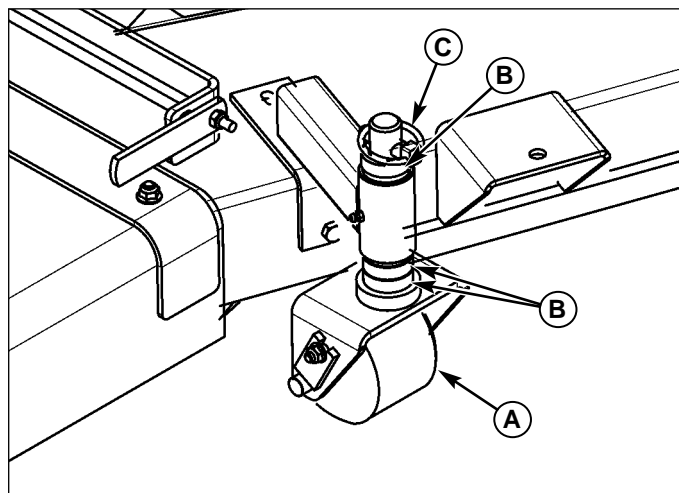

Figure 25. Anti-Scalp Deck Casters

- A. Deck Caster
- B. Spacer
- C. Lynch Pin

SERVICING THE MOWER BLADES

1. Blades should be sharp and free of nicks and dents. If not, sharpen blades as described in following steps.
2. To remove blade for sharpening, use a 1" wrench on the flats of the spindle shaft while removing the blade mounting bolt with a 15/16" wrench (Figure 26).
3. Use a file to sharpen blade to fine edge. Remove all nicks and dents in blade edge. If blade is severely damaged, it should be replaced.
4. Balance the blade as shown in Figure 27. Center the blade's hole on a nail lubricated with a drop of oil. A balanced blade will remain level.
5. Reinstall each blade with the tabs pointing up toward deck as shown in Figure 28. Secure with a bolt and flat washer and torque bolts to 70 ft.lbs. (94 N.m.).

WARNING

Mower blades are sharp. For your personal safety, do not handle mower blades with bare hands. Careless or improper handling of blades may result in serious injury. For your personal safety, blade mounting bolts must each be installed with a flat washer then securely tightened. Torque blade mounting bolts to 70 ft.lbs. (94 N.m.)

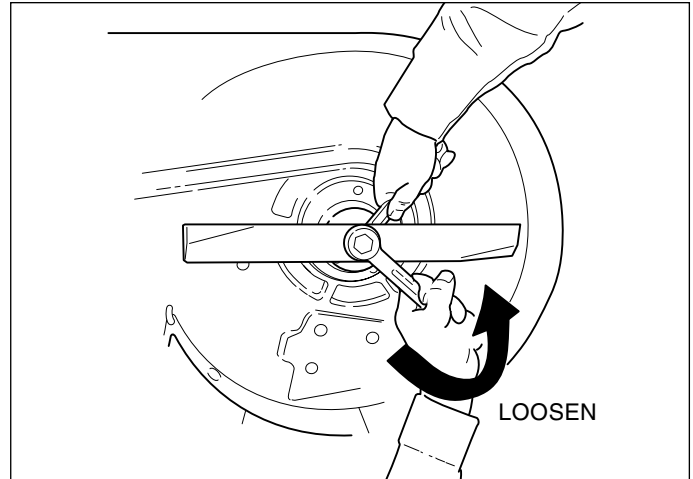

Figure 26. Removing the Blade

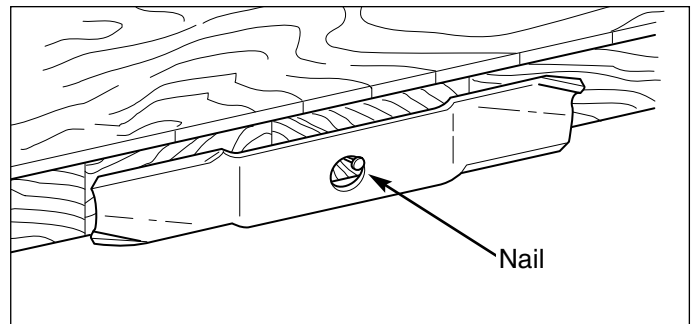

Figure 27. Balancing The Blade

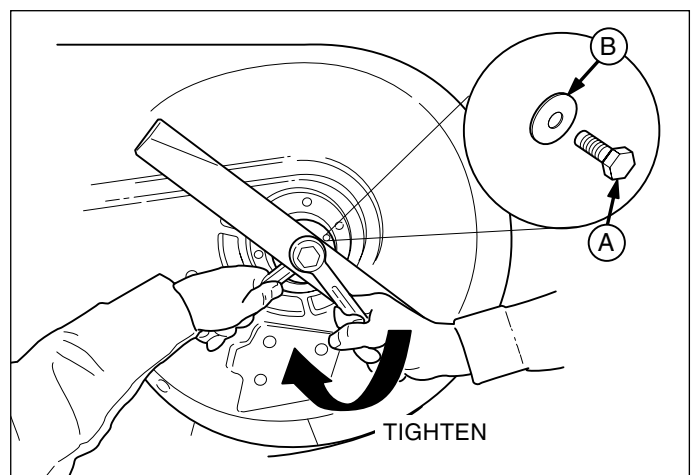

Figure 28. Installing The Blade

- A. Blade Bolt
- B. Flat Washer

Troubleshooting Adjustments & Service

TROUBLESHOOTING

While normal care and regular maintenance will extend the life of your equipment, prolonged or constant use may eventually require that service be performed to allow it to continue operating properly.

The troubleshooting guide below lists the most common problems, their causes and remedies.

See the information on the following pages for instructions on how to perform most of these minor adjustments and service repairs yourself. If you prefer, all of these procedures can be performed for you by your local authorized dealer.

WARNING

To avoid serious injury, perform maintenance on the tractor or mower only when the engine is stopped and the parking brake engaged.

Always remove the ignition key to prevent accidental starting of the engine.

TROUBLESHOOTING THE RIDER

PROBLEM	CAUSE	REMEDY
Engine will not turnover or start.	1. Parking brake not engaged.	1. Engage parking brake.
	2. PTO (electric clutch) switch in ON position.	2. Place in OFF position.
	3. Out of fuel.	3. If engine is hot, allow it to cool, then refill the fuel tanks. Prime the fuel system.
	4. Motion Control Handles not locked in neutral position.	4. Lock handles in neutral position.
	5. Operator not in seat.	5. Assume operator's position in seat.
	6. Glow plugs not pre-heated.	6. Pre-heat glow plugs.
	7. Fuse blown.	7. Replace fuse.
	8. Battery terminals require cleaning.	8. Clean the battery terminals
	9. Battery discharged or dead.	9. Recharge or replace.
	10. Wiring loose or broken.	10. Visually check wiring & replace broken or frayed wires. Tighten loose connections.
	11. Solenoid or starter motor faulty.	11. Repair or replace. See authorized service dealer
	12. Safety interlock switch faulty.	12. Replace as needed. See authorized service dealer.
	13. Water in fuel.	13. Drain fuel & refill with fresh fuel.
	14. Fuel is old or stale.	14. Drain fuel & replace with fresh fuel.
Engine starts hard or runs poorly.	1. Fuel mixture too rich.	1. Clean air filter.
	2. Air in fuel system.	

Rider Troubleshooting Continued.

PROBLEM	CAUSE	REMEDY
Engine runs, but rider will not drive.	<ol style="list-style-type: none">1. Hydraulic dump valve(s) in "open" position.2. Belt is broken.3. Drive belt slips.4. Brake is not fully released.	<ol style="list-style-type: none">1. Turn dump valve(s) clockwise to close. Torque to 80-120 in.lbs. (9-13.5 N.m.)2. See Drive Belt Replacement.3. See problem and cause below.4. See authorized service dealer
Hydraulic pump drive belt slips.	<ol style="list-style-type: none">1. Pulleys or belt greasy or oily.2. Belt stretched or worn.	<ol style="list-style-type: none">1. Clean as required.2. Replace belt.
Brake will not hold.	<ol style="list-style-type: none">1. Brake is incorrectly adjusted.2. Brake caliper pads worn.	<ol style="list-style-type: none">1. See Brake Adjustment.2. Replace with new brake pads.
Rider steers or handles poorly.	<ol style="list-style-type: none">1. Steering linkage is loose.2. Improper tire inflation.	<ol style="list-style-type: none">1. Check and tighten any loose connections.2. See Regular Maintenance Section.

TROUBLESHOOTING THE MOWER

PROBLEM	CAUSE	REMEDY
Mower will not raise.	<ol style="list-style-type: none">1. Lift linkage not properly attached or damaged.	<ol style="list-style-type: none">1. See authorized service dealer for repair.
Mower cut is uneven.	<ol style="list-style-type: none">1. Mower not leveled properly.2. Rider tires not inflated equally or properly.	<ol style="list-style-type: none">1. See Mower Adjustment.2. See Regular Maintenance Section.
Mower cut is rough looking.	<ol style="list-style-type: none">1. Engine speed too slow.2. Ground speed too fast.3. Blades are dull.4. Mower drive belt slipping because it is oily or worn.5. Blades not properly fastened to spindles.	<ol style="list-style-type: none">1. Set throttle to full.2. Decrease Ground Speed.3. Sharpen or replace blades. See Mower Blade Service.4. Clean or replace belt as necessary.5. See Servicing the Mower Blades.
Engine stalls easily with mower engaged.	<ol style="list-style-type: none">1. Engine speed too slow.2. Ground speed too fast.3. Cutting height set too low.4. Discharge chute jamming with cut grass.	<ol style="list-style-type: none">1. Set to full throttle.2. Decrease Ground Speed.3. Cut tall grass at maximum cutting height during first pass.4. Cut grass with discharge pointing toward previously cut area.
Excessive mower vibration.	<ol style="list-style-type: none">1. Blade mounting bolts are loose.2. Mower blades, spindles, or pulleys are bent.3. Mower blades are out of balance.4. Belt installed incorrectly.	<ol style="list-style-type: none">1. Tighten to 70 ft.lbs. (94 N.m.).2. Check and replace as necessary.3. Remove, sharpen, and balance blades. See Maintenance Section.4. Reinstall Correctly.
Excessive belt wear or breakage.	<ol style="list-style-type: none">1. Bent or rough pulleys.2. Using incorrect belt.	<ol style="list-style-type: none">1. Repair or replace.2. Replace with correct belt.
Mower drive belt slips or fails to drive.	<ol style="list-style-type: none">1. Idler pulley spring broken or not properly attached.2. Mower drive belt broken.	<ol style="list-style-type: none">1. Repair or replace as needed.2. Replace drive belt.

SEAT ADJUSTMENT

See Figure 29. The seat can be adjusted fore and aft. Move the lever forward, position the seat as desired, and release the lever to lock the seat into position.

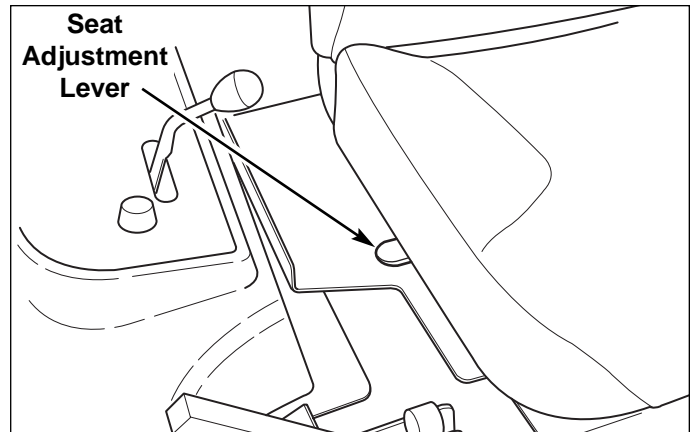

Figure 29. Seat Adjustment

GROUND SPEED CONTROL LEVER ADJUSTMENT

The control levers can be adjusted in three ways. The alignment of the control levers, the placement of the levers (how close the ends are to one another) and the height of the levers can be adjusted.

Handle Alignment

Loosen the mount hardware (A, Figure 30) and pivot the lever(s) (C, Figure 30) fore or aft to align with each other.

Handle Placement

Loosen the jam nuts and adjust the placement bolt (B, Figure 30) in or out to properly adjust the lever end spacing.

Handle Height

Remove the mounting hardware (A, Figure 30) and reposition the handle either up or down from its original position. You will need to readjust the handle alignment as described above.

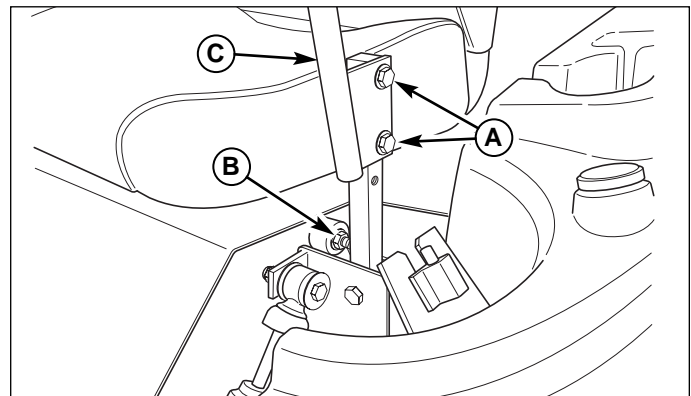

Figure 30. Control Lever Adjustment

- A. Alignment Hardware
- B. Placement Hardware
- C. Ground Speed Control Lever

SPEED BALANCING ADJUSTMENT

If the rider veers to the right or left when the ground speed control levers are in the maximum forward position, the top speed of each of these levers can be balanced by turning the adjustment bolt(s) (A, Figure 31). Only adjust the speed of the wheel that is traveling faster.

To Reduce the Speed of the Faster Wheel

1. Loosen the flange nuts.
2. turn the top speed adjustment bolt COUNTER-CLOCKWISE to reduce the speed.
3. Retighten the flange nuts when adjustment is complete.

! WARNING

DO NOT adjust the tractor for a faster overall speed forward or reverse than it was designed for.

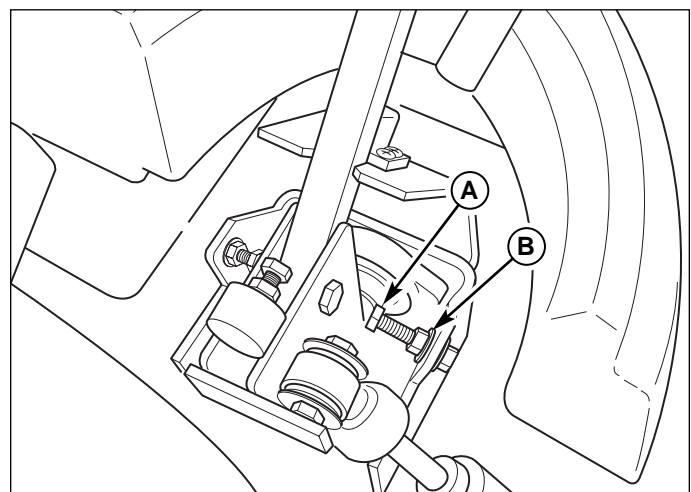

Figure 31. Top Speed Adjustment

- A. Top Speed Adjustment Bolt
- B. Flange Nut

NEUTRAL POSITION AND RETURN SPRING ADJUSTMENT

To determine if it is necessary to adjust the neutral position, perform the following steps.

1. Disengage the PTO, engage the parking brake and turn off the engine.
2. Move the ground speed control levers in the operating position, pull levers rearward and release.
3. Move the ground speed control levers towards the neutral position. If the levers do not align with the notches in the neutral lock plate, it is necessary to adjust the reverse return bolts (A, Figure 32).

Neutral Position Adjustment

1. Loosen the jam nut (D, Figure 32) locked against the clevis.
2. Turn the reverse return bolt (A) clockwise to adjust handle rearward, counter-clockwise to adjust handle forward.
4. Pull lever rearward and release to check position again. Adjust as necessary to align levers with notches.

It is important to note that after every adjustment of the reverse return bolt, the lever must be pulled rearward and released to properly check the neutral position.

5. Once the lever alignment has been adjusted, lock jam nut against the clevis.

Return Spring Adjustment

After adjusting the neutral position, lock the levers in the neutral position and measure the reverse return spring (B, Figure 32) length. This should be 2-3/8" (6,03 cm) long. If not, hold the reverse return bolt (A) with a wrench while turning the spring position nut (C) until the measurement is achieved.

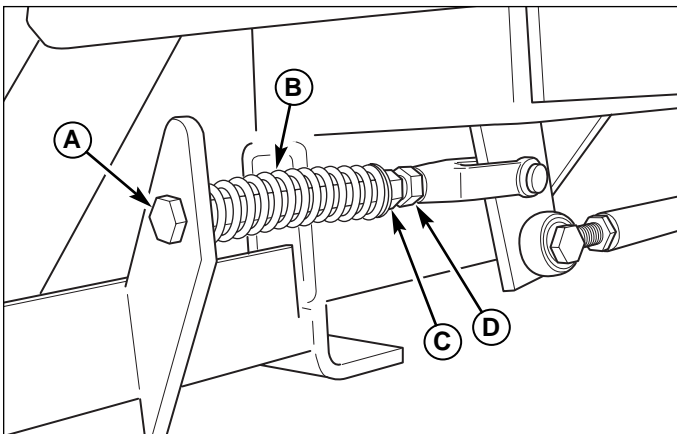

Figure 32. Neutral Spring Return Adjustment

- A. Reverse Return Bolt
- B. Reverse Return Spring
- C. Spring Position Nut
- D. Jam Nut

NEUTRAL ADJUSTMENT

If the tractor "creeps" while the ground speed control levers are locked in NEUTRAL, then it may be necessary to adjust the control linkage.

NOTE: Perform this adjustment on a hard, level surface such as a concrete floor. The neutral position MUST be checked and adjusted BEFORE performing a neutral adjustment.

1. Disengage the PTO, engage the parking brake and turn off the engine.
2. Loosen the jam nuts (B, Figure 33) and turn the adjustment linkage (A) to adjust. If the machine creeps forward, turn the linkage CLOCKWISE (while standing at the rear of the machine, facing forward), if the machine creeps backward, turn the linkage COUNTER-CLOCKWISE.
3. Lock the jam nuts (B) when neutral is achieved.

NOTE: This adjustment should NOT be performed while the machine is running. It may take several attempts to achieve neutral, depending upon how much the machine creeps.

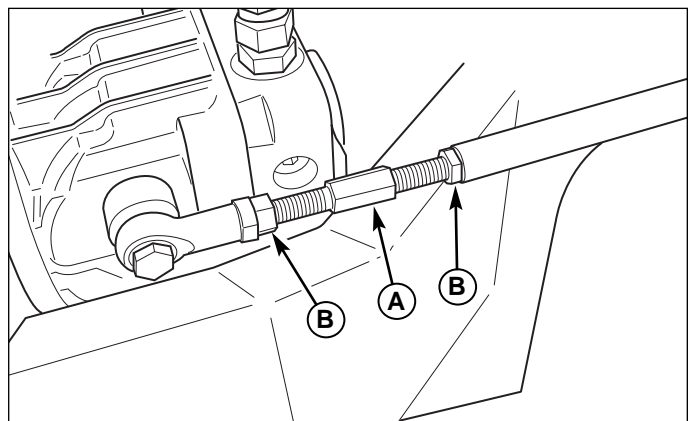

Figure 33. Neutral Adjustment

(Left-hand side shown)

- A. Control Linkage
- B. Jam Nuts

Adjustment & Service

WHEEL ADJUSTMENT

Stop the engine, block the front parking brake, insert the ignition key, and engage the parking brake.

Remove the front wheel and secure with a wheel chock behind both drive tires.

With the parking brake engaged, measure the compressed spring length (see Figure 34). The spring should be 2-1/8" (5,4 - 5,7 cm) long when compressed.

With the parking brake released, measure 2-1/8" - 2-1/4" (5,4 - 5,7 cm), insert the parking brake and turn the set collar to adjust the spring length.

Release the parking brake and remeasure the spring length. Adjust the nut as required.

CAUTION

Spring adjustment should be shorter than 2-1/8" (5,4 cm) when compressed. This may damage the brake.

When the parking brake is engaged, adjust the set collar until the gap is measured between the spring and the brake link.

Install the drive shaft and the lug bolts to 105 ft/lbs. (142 Nm). Remove the jackstands from under the machine.



DECK LIFT ROD TIMING ADJUSTMENT

1. Park machine on a flat, level surface. Disengage the PTO, stop the engine and engage the parking brake. Rear tires must be inflated to 18 psi (1,24 bar); front tires to 25 psi (1,72 bar).
2. Install the cutting height adjustment pin in the 3-3/4" (9,5 cm) position. See Figure 36.
3. To check the lift rod timing, measure and record the distance between the lift pivots and the rod pivots. Repeat for other side of unit. See Figure 37.
4. If the measurements for the rods and pivots are equal, no further adjustment is required. If the measurements are NOT equal (greater than 1/8" (3,17mm) difference), adjustment is required, continue with Step 5.
5. Refer to Figure 37. To adjust the lift rods, adjust the 5/8" hex nuts on either side of the front lift pivot until the measurements are equal. Repeat for other side. Make sure the nylon lock nut on the end of the rod towards the rear of the machine is loose to allow the rod to turn in the rear lift pivot.
6. Refer to Figure 38. Measure the distance from the front lift pivot to the ground and from the front chain anchor bolt to the ground. If the measurements are equal, no further adjustment is required. If the measurements are NOT equal (greater than 1/8" (3,17mm) difference), adjustment is required, continue with Step 7.
7. Raise the seat plate to access the center lift link (A, Figure 39).
8. Loosen the jam nut (C) on the lift clevis (D) and turn the adjuster bolt (B) until the measurements are equal. Tighten the jam nut against the lift clevis.

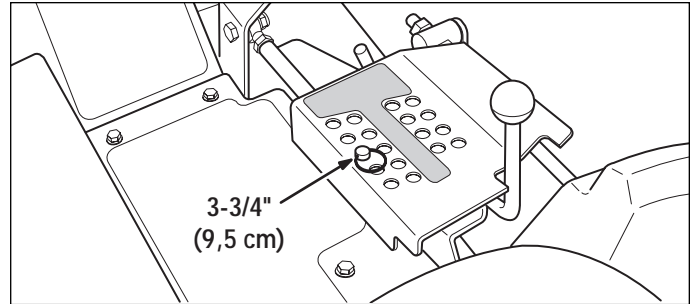

Figure 36. Deck Height Pin Position

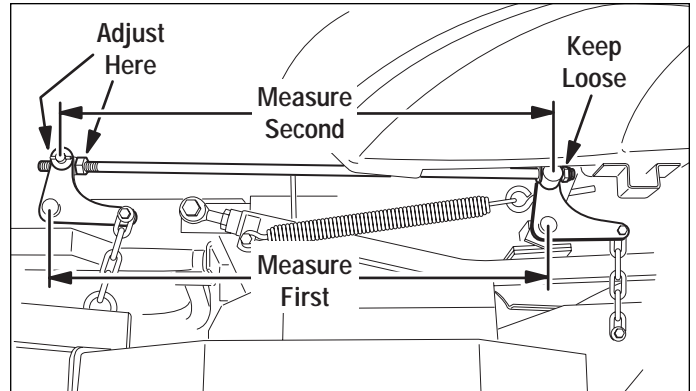

Figure 37. Measure & Adjust Lift Rod Timing

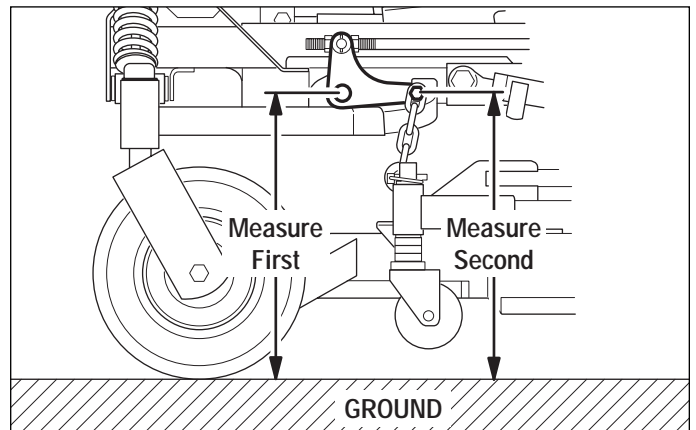

Figure 38. Measure Front Lift Pivot

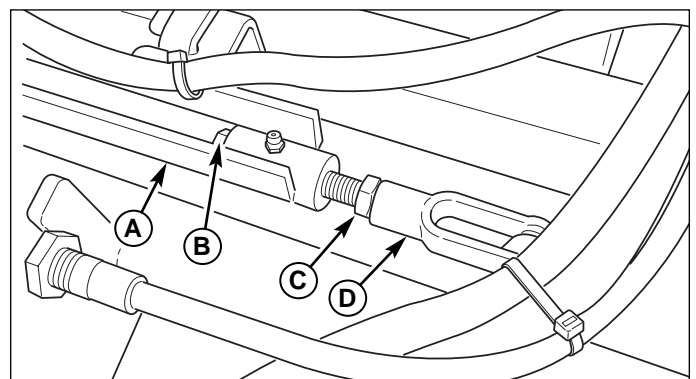

Figure 39. Center Lift Link Adjustment

- A. Center Lift Link
- B. Adjuster Bolt
- C. Jam Nut
- D. Lift Clevis

DECK LEVELING ADJUSTMENT

NOTE: Before adjusting the deck level, the deck lift rod timing must be checked and/or adjusted.

1. Park machine on a flat, level surface. Disengage the PTO, stop the engine and engage the parking brake. Rear tires must be inflated to 18 psi (1,24 bar); front tires to 25 psi (1,72 bar).
2. Install the cutting height adjustment pin in the 4" (10,2 cm) position. See Figure 40.
3. Place 2 x 4 blocks under each corner of the mower deck with the 3-1/2" sides being vertical. Place a 1/4" (0,64 cm) thick spacer on top of the rear 2 x 4 blocks. See Figure 41.
4. Adjust the front eyebolts until the chains are tight and the deck is still resting on the 2 x 4's. Tighten jam nuts. See Figure 42.
5. Loosen the nuts and allow the rear of the deck to rest on the 2 x 4's and 1/4" spacers. Slide the chains in the slots until the chains are tight and tighten the nuts. See Figure 42.
6. Remove all 2 x 4 blocks and spacers from under the mower deck.

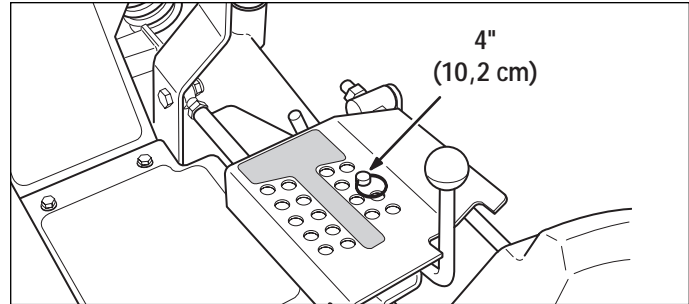

Figure 40. Deck Height Pin Position

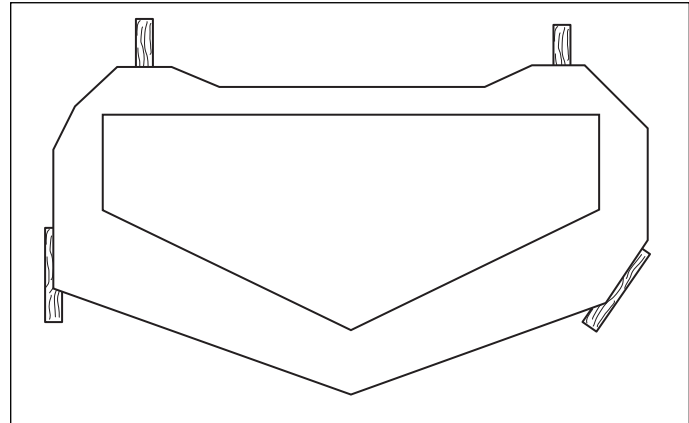

Figure 41. 2 x 4 Locations

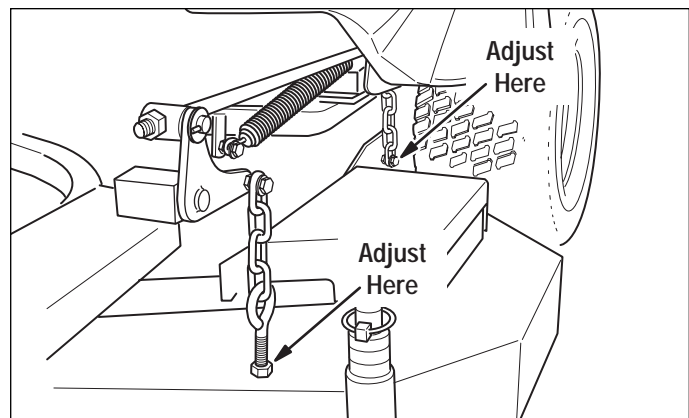

Figure 42. Deck Level Adjustment

DECK LIFT SPRING

The deck lift springs (A, Figure 43) are factory set to provide optimal lifting performance.

Although it is fastened with an adjustable anchor, this is **NOT AN ADJUSTMENT POINT**.

DO NOT attempt to adjust the spring length or lifting performance will be compromised.

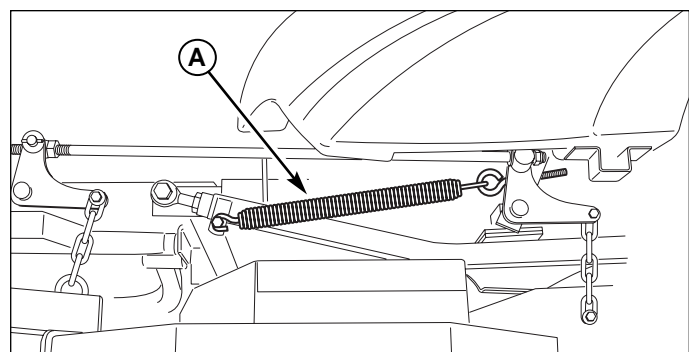

Figure 43. Deck Lift Spring Location

A. Deck Lift Spring

SUSPENSION ADJUSTMENT

This unit is equipped with adjustable shock assemblies. The shocks can be adjusted to vary the amount of pre-load applied to the springs. This allows the operator to customize the ride according to operator's weight and/or operating conditions.

Less Pre-Load:

- Light operator weight
- Softer, more cushioned ride
- Best for relatively flat terrain

More Pre-Load:

- Heavy operator weight
- Stiffer, more rigid ride
- Better handling and greater stability on hilly terrain

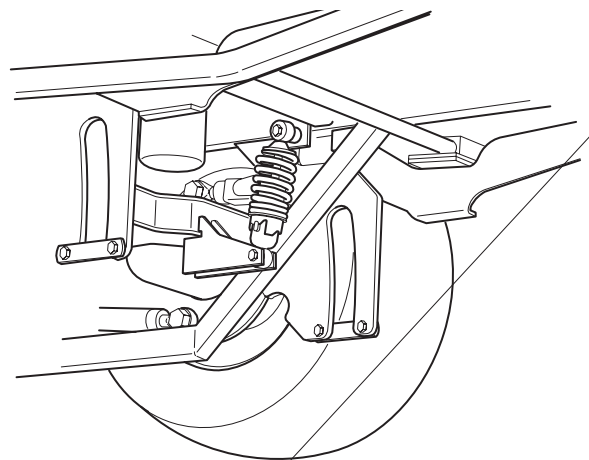
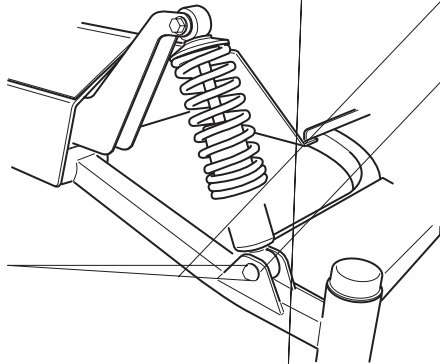

& Service

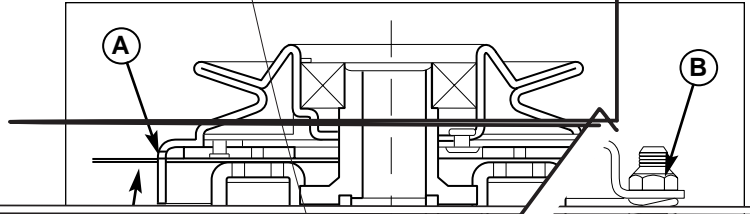

BELT REMOVAL & REPLACEMENT

! WARNING

If servicing the belts after the engine has been running, use extreme caution when raising the hood or lowering the rear shield. The surface of the hood and rear shield can be hot from the muffler and exhaust manifold.

Pump Drive Belt Removal

1. Park the tractor on a smooth, level surface such as a concrete floor. Disengage the PTO, engage the parking brake, turn off the engine, and remove the ignition key.
2. Remove the PTO drive belt from the clutch (see *PTO DRIVE BELT REMOVAL* for instructions).
3. Using a 1/2" breaker bar, place the square end in the square hole located in the middle of the idler arm (A, Figures 47). Carefully rotate the breaker bar COUNTER-CLOCKWISE, which will relieve the tension on the belts exerted from the idler arm.
4. Remove the belts from the right-hand and left-hand pump drive pulley grooves.
5. Carefully release the tension on the breaker bar.
6. Unhook the spring (B) from the anchor bolt on the idler arm.
7. Remove the belts from the crankshaft pulley grooves and pull out from behind the clutch.

Pump Drive Belt Replacement

1. Place the belts under clutch into the crankshaft pulley grooves.
2. Wrap the belts around the top side of the idler arm pulley and install the belts in the right-hand pump pulley grooves.
3. Reinstall the spring onto the anchor bolt on the idler arm.
4. Carefully rotate the idler arm with the breaker bar counter-clockwise (see Figure 47). While holding the breaker bar firmly, install the belts in the left-hand pump pulley grooves and the two stationary idler pulleys grooves.
5. Carefully release the tension on the breaker bar.
6. Inspect the belt path making sure that all belts are properly seated in the pulley grooves.
7. Reinstall the PTO drive belt from the clutch (see *PTO DRIVE BELT REPLACEMENT* for instructions).

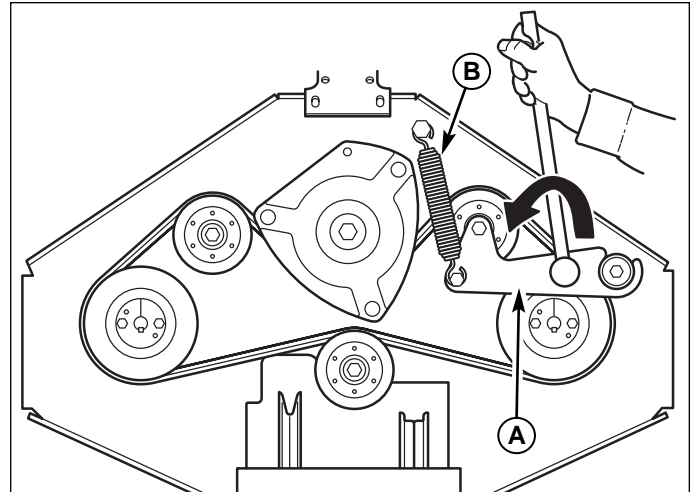

Figure 47. Pump Belt Removal & Replacement

- A. Pump Drive Idler Arm
- B. Spring



To avoid damaging belts, DO NOT PRY BELTS OVER PULLEYS.

! WARNING

Use extreme caution when rotating the idler arm with the breaker bar, due to the increased tension in the spring as the idler arm is being rotated. Injury may result if the breaker bar is prematurely released while the spring is under tension.

PTO Drive Belt Removal

1. Park the tractor on a smooth, level surface such as a concrete floor. Disengage the PTO, engage the parking brake, turn off the engine, and remove the ignition key.
2. Release the hood cam latches and raise the hood until it locks in place.
3. Release the rear guard cam latches and lower or remove the rear guard.
4. Using a 3/4" box end wrench on the nut of the spring-loaded idler pulley (A, Figure 48), rotate the wrench **CLOCKWISE** to release the tension on the PTO drive belt.

! WARNING

Use extreme caution when rotating the idler pulley with the wrench, due to the increased tension in the spring as the idler pulley is being rotated. Injury may result if the wrench is prematurely released while the spring is under tension.

5. Remove the belt from the stationary idler pulley (B, Figure 48).
6. Carefully release the tension on the wrench.
7. Remove the belt from the PTO clutch pulley, spring-loaded idler pulley and center spindle pulley.
8. Pull the belt towards the rear of the machine until free of the guide pulleys and belt keeps on the rear of the mower deck.

PTO Drive Belt Replacement

1. From the rear of the mower deck, route the new belt through the guide pulleys and belt keeps.
2. Install the belt on the center spindle pulley. Follow the illustration in Figure 49 carefully. Make sure the belt twists in the correct direction.
3. Install the belt over the PTO clutch pulley and the spring loaded idler pulley. Again, follow the illustration in Figure 49 carefully and make sure the belt twists in the correct direction.
4. Using a 3/4" box end wrench on the nut of the idler pulley (A, Figure 48), rotate the wrench **CLOCKWISE** and install the belt on the stationary idler pulley.
5. Carefully release the tension on the wrench.

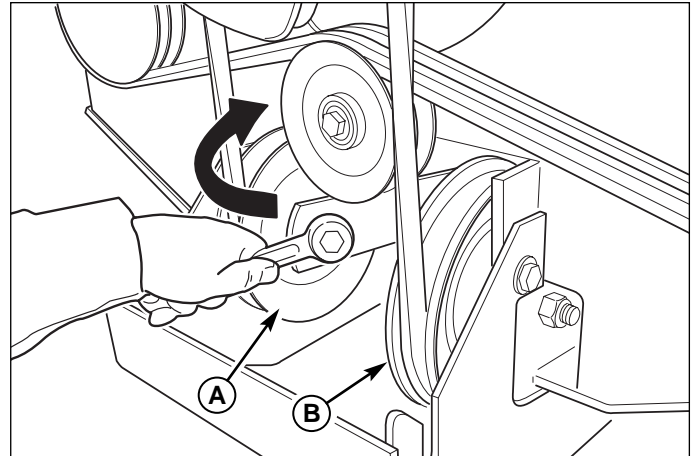

Figure 48. PTO Drive Belt Removal

- A. Spring Loaded Idler Pulley
- B. Stationary Idler Pulley

Spindle Drive Belt Removal & Replacement

1. Park the tractor on a smooth, level surface such as a concrete floor. Disengage the PTO, engage the parking brake, turn off the engine, and remove the ignition key.
2. Remove the PTO drive belt from the center spindle pulley (see *PTO DRIVE BELT REMOVAL* for instructions).
3. Using a 1/2" breaker bar, place the square end in the square hole located near the end of the idler arm (A, Figures 50). Carefully rotate the breaker bar **CLOCKWISE**, which will relieve the tension on the belts exerted from the idler arm.

! WARNING

Use extreme caution when rotating the idler arm with the breaker bar, due to the increased tension in the spring as the idler arm is being rotated. Injury may result if the breaker bar is prematurely released while the spring is under tension.

4. Remove the belt from the trim side spindle pulley (B, Figure 50).
5. Carefully release the tension on the breaker bar.
6. Remove the old belt and replace with a new one. Make sure the V-side of the belt runs in the pulley grooves (Figure 51).
7. Install the belt on all of the pulleys, except for the trim side spindle pulley. Carefully rotate the breaker bar **CLOCKWISE** and install the belt on the trim side spindle pulley. Carefully release the tension on the breaker bar.
8. Reinstall the PTO drive belt.

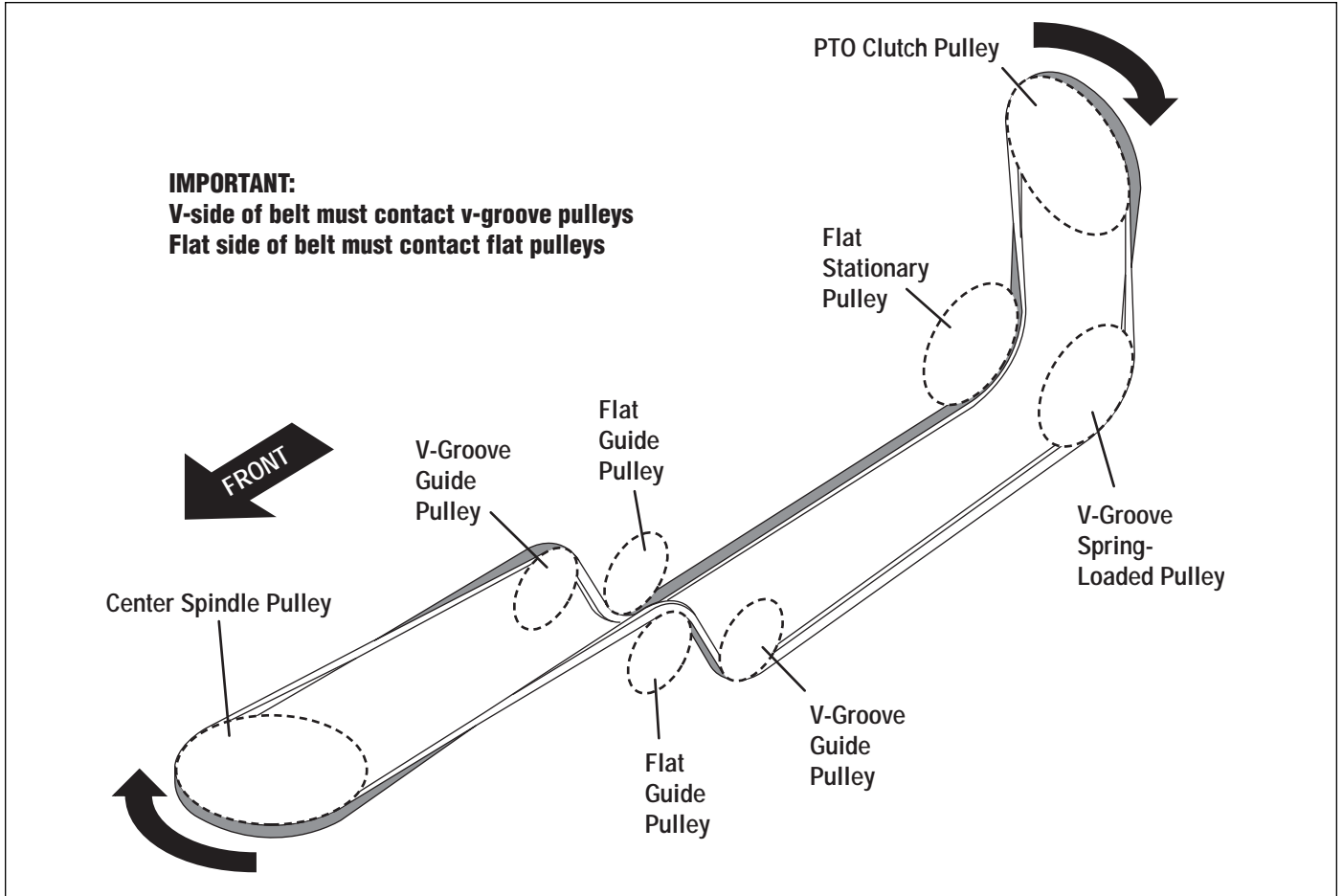

Figure 49. PTO Belt Routing

NOTE: Gray areas indicate the flat side of the belt.

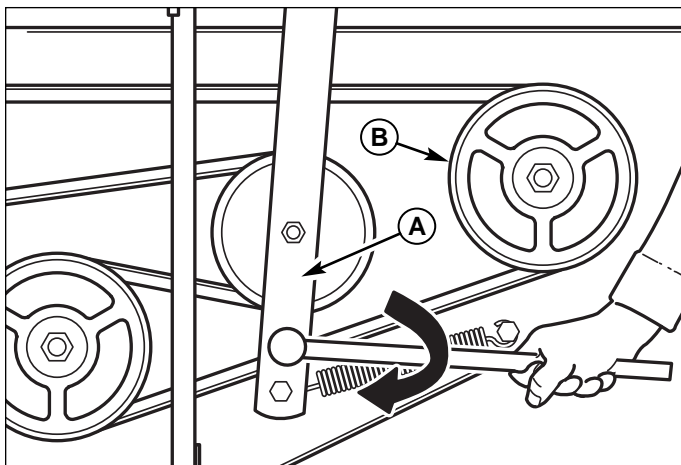

Figure 50. Spindle Drive Belt Removal

- A. Idler Arm
- B. Trim Side Spindle Pulley

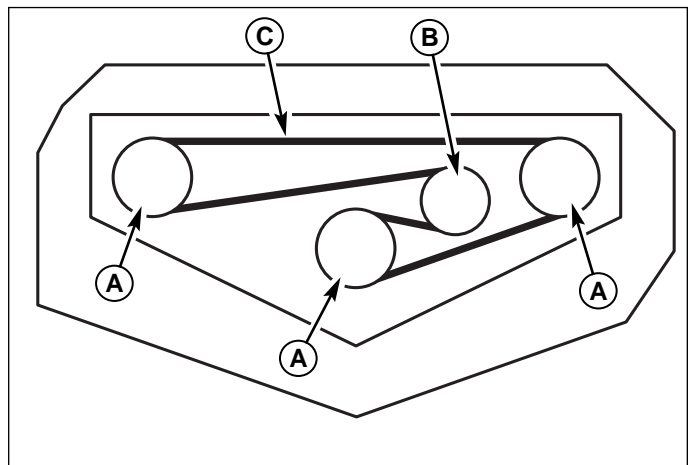

Figure 51. Spindle Drive Belt Removal

- A. Spindle Pulley
- B. Idler Pulley
- C. Drive Belt

BATTERY SERVICE

WARNING

Keep open flames and sparks away from the battery; the gasses coming from it are highly explosive. Ventilate the battery well during charging.

Checking Battery Voltage

A voltmeter can be used to determine condition of battery. When engine is off, the voltmeter shows battery voltage, which should be 12 volts. When engine is running, the voltmeter shows voltage of charging circuit which normally is 13 to 14 volts.

A dead battery or one too weak to start the engine may not mean the battery needs to be replaced. For example, it may mean that the alternator is not charging the battery properly. If there is any doubt about the cause of the problem, see your dealer. If you need to replace the battery, follow the steps under Cleaning the Battery & Cables in the Regular Maintenance Section.

CHARGING A COMPLETELY DISCHARGED BATTERY

1. Be aware of all the safety precautions you should observe during the charging operation. If you are unfamiliar with the use of a battery charger and hydrometer, have the battery serviced by your dealer.
2. Add distilled water sufficient to cover the plate (fill to the proper level near the end of the charge). If the battery is extremely cold, allow it to warm before adding water because the water level will rise as it warms. Also, an extremely cold battery will not accept a normal charge until it becomes warm.
3. Always unplug or turn the charger off before attaching or removing the clamp connections.
4. Carefully attach the clamps to the battery in proper polarity (usually red to [+] positive and black to [-] negative).
5. While charging, periodically measure the temperature of the electrolyte. If the temperature exceeds 125° F (51.6° C), or if violent gassing or spewing of electrolyte occurs, the charging rate must be reduced or temporarily halted to prevent battery damage.

6. Charge the battery until fully charged (until the specific gravity of the electrolyte is 1.250 or higher and the electrolyte temperature is at least 60° F). The best method of making certain a battery is fully charged, but not over charged, is to measure the specific gravity of a cell once per hour. The battery is fully charged when the cells are gassing freely at low charging rate and less than 0.003 change in specific gravity occurs over a three hour period.

JUMP STARTING WITH AUXILIARY (BOOSTER) BATTERY

Jump starting is not recommended. However, if it must be done, follow these directions. Both booster and discharged batteries should be treated carefully when using jumper cables. Follow the steps below EXACTLY, being careful not to cause sparks. Refer to Figure 52.

1. Both batteries must be of the same voltage.
2. Position the vehicle with the booster battery adjacent to the vehicle with the discharged battery so that booster cables can be connected easily to the batteries in both vehicles. Make certain vehicles do not touch each other.
3. Wear safety glasses and shield eyes and face from batteries at all times. Be sure vent caps are tight. Place damp cloth over vent caps on both batteries.
4. Connect positive (+) cable to positive post of discharged battery (wired to starter or solenoid).
5. Connect the other end of same cable to same post marked positive (+) on booster battery.
6. Connect the second cable negative (-) to other post of booster battery.
7. Make final connection on engine block of stalled vehicle away from battery. Do not lean over batteries.
8. Start the engine of the vehicle with the booster battery. Wait a few minutes, then attempt to start the engine of the vehicle with the discharged battery.
9. If the vehicle does not start after cranking for thirty seconds, STOP PROCEDURE. More than thirty seconds seldom starts the engine unless some mechanical adjustment is made.
10. After starting, allow the engine to return to idle speed. Remove the cable connection at the engine or frame. Then remove the other end of the same cable from the booster battery.
11. Remove the other cable by disconnecting at the discharged battery first and then disconnect the opposite end from the booster battery.
12. Discard the damp cloths that were placed over the battery vent caps.

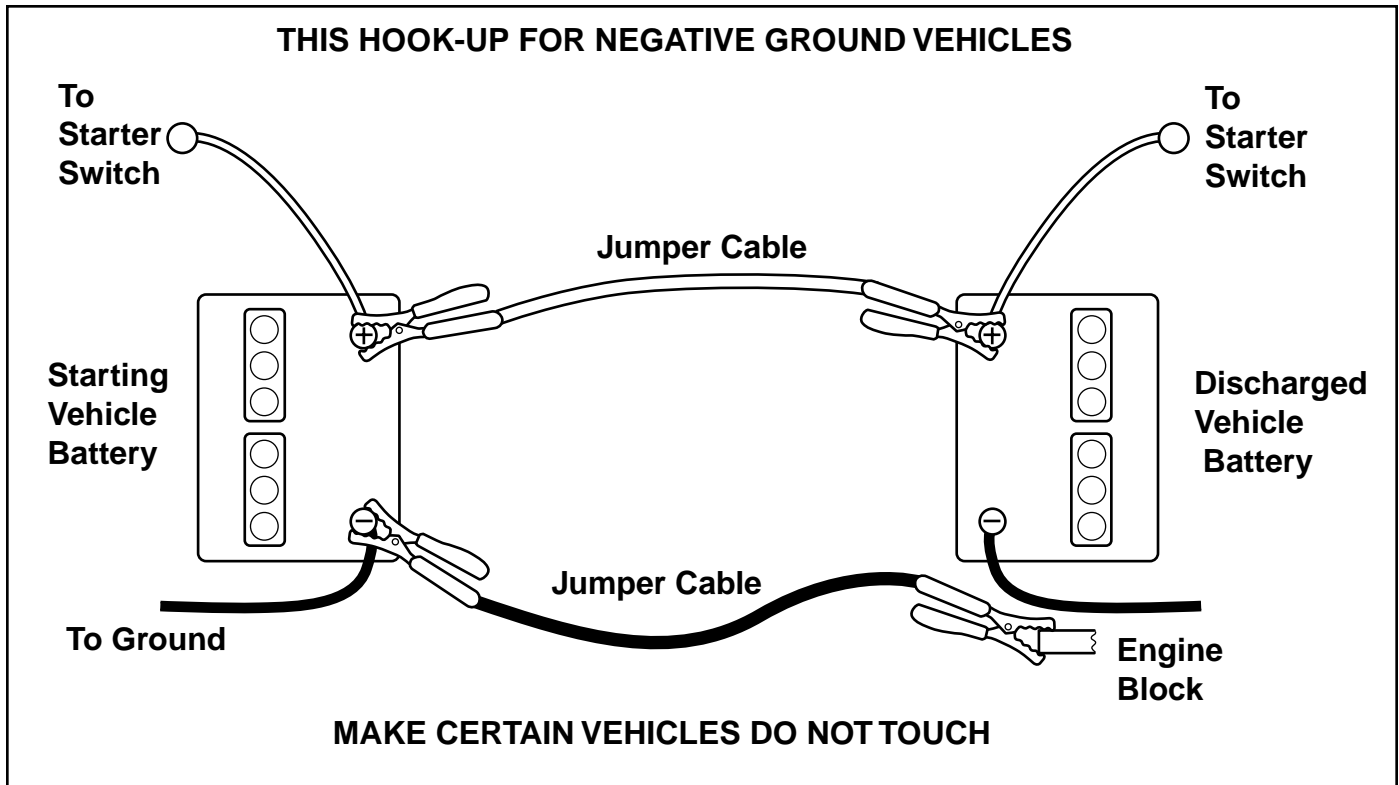

Figure 52. Jump Starting

⚠ WARNING

Any procedure other than the preceding could result in:

- (1) personal injury caused by electrolyte squirting out the battery vents,
- (2) personal injury or property damage due to battery explosion,
- (3) damage to the charging system of the booster vehicle or of the immobilized vehicle.

Do not attempt to jump start a vehicle having a frozen battery because the battery may rupture or explode. If a frozen battery is suspected, examine all fill vents on the battery. If ice can be seen or if the electrolyte fluid cannot be seen, do not attempt to start with jumper cables as long as the battery remains frozen.

⚠ WARNING

For your personal safety, use extreme care when jump starting. Never expose battery to open flame or electric spark – battery action generates hydrogen gas which is flammable and explosive. Do not allow battery acid to contact skin, eyes, fabrics, or painted surfaces. Batteries contain a sulfuric acid solution which can cause serious personal injury or property damage.

When removing or installing battery cables, disconnect the negative cable **FIRST** and reconnect it **LAST**. If not done in this order, the positive terminal can be shorted to the frame by a tool.

To avoid engine damage, do not disconnect battery while engine is running. Be sure terminal connections are tight before starting.

Specifications



NOTE: Specifications are correct at time of printing and are subject to change without notice.

** Actual sustained equipment horsepower will likely be lower due to operating limitations and environmental factors.*

ENGINE:

28 HP* Caterpillar

Make	Caterpillar
Model	3011C
Horsepower	28 @ 3600 rpm
Displacement	69 Cu. in (1131 cc)
Electrical System	12 Volt, 40 amp. Alternator, Battery: 500 CCA
Oil Capacity	5.2 US qt. (4.9 L) w/ Filter

35 HP* Briggs

Make	Briggs & Stratton
Model	613177
Horsepower	35 @ 3600 rpm
Displacement	61 Cu. in (993 cc)
Electrical System	12 Volt, 20 amp. Alternator, Battery: 500 CCA
Oil Capacity	2.4 US qt. (2.25 L) w/ Filter

CHASSIS:

Fuel Tanks	Capacity: 15 Gallons (56.8 L) Total
Rear Wheels	Tire Size: 24 x 12.00 - 12 Inflation Pressure: 18 psi (1,24 bar)
Front Wheels	Tire Size: 13 x 6.50 - 6 Inflation Pressure: 25 psi (1,72 bar)

TRANSMISSIONS:

HydroGear BDP-21 / Parker TF-040

Type	Pump and Wheel Motor
Hydraulic Fluid	Mobil 1™ 15W-50 synthetic oil or Castrol Syntec™ 5W-50 oil
Speeds	Forward: 0-10 MPH (0-16.1 km/h) Reverse: 0-5 MPH (0-8.05 km/h)
@ 3400 rpm	
Continuous Torque	483 ft. lbs. (654 N.m.)
Output	
Maximum Weight on Axle	3000 lbs. (1360 Kg)

DIMENSIONS:

Overall Length	86-1/2" (220 cm)
Overall Width	75" (191 cm) - side discharge model 62" (158 cm) - rear discharge model
Height	52" (132 cm)
Weight (apx..)	
With Side Discharge Mower Deck	1846 lbs. (837 kg)
With Rear Discharge Mower Deck	1868 lbs. (847 kg)



Lawn Care & Mowing Information

GENERAL INFORMATION

Proper mowing is an important part of maintaining your lawn in the best possible condition. A healthy and well maintained lawn is better able to resist drought, weeds, and other stresses. But too much maintenance is as detrimental to your lawn as neglect. Proper care for your lawn involves more than just "cutting the grass." To have a healthy lawn, you need to know:

- Types of Grass, Climate and Conditions
- How and When to Water, Fertilize & Aerate
- How High to Mow the Grass
- When and How Often to Mow
- What Mowing Patterns to Use
- Proper Mowing Methods
- How to Solve Common Mowing Problems

TYPES OF GRASS, CLIMATE AND CONDITIONS

A variety of grasses are commonly grown in household lawns, but two main groups known as cool-season grasses (varieties of bluegrass, ryegrass, and fescue), and warm-season grasses (typically bermuda, buffalo grass, and zoysia varieties) are the most common.

The cool-season grasses are better suited to cooler climates, and do not endure hot and dry weather as well as warm-season grasses, but conversely, the warm-season grasses do not grow as well in cooler climates. Most residential lawns are typically seeded with a mixture of these grasses. (A local nursery or lawn center may help you to identify what kind of grass your lawn contains from a sample.)

Knowing your climate and conditions is also important to proper lawn care. Drier climates or conditions will require additional watering, while wetter climates may require more frequent mowing.

HOW AND WHEN TO WATER, FERTILIZE & AERATE

Every lawn's watering needs are unique and are dependent upon the type of grass and soil, the amount of local rainfall, and other conditions. **Most lawns are watered too often, but with too little water.** However too much water can allow development of diseases with your lawn. **It is best to water the lawn only when necessary, and then to water it slowly, evenly, and deeply—imitating a slow, soaking rain.**

WHEN TO WATER YOUR LAWN

When the lawn begins to wilt, the grass's color dulls, or footprints stay compressed for more than a few seconds, the lawn is beginning to dry out, and needs additional moisture. The best time to water is early morning to allow the water to soak deeply into the lawn and reduce the amount that evaporates in the hot afternoon sun.



HOW TO WATER YOUR LAWN

The best method of watering a lawn is to imitate a slow, soaking rain, applying about 1 inch of water. A method of verifying the amount that you have watered, is to place several empty tin cans (low shallow cans work best) in various spots around the lawn, and check the depth of water in the can during the watering process.

HOW TO FERTILIZE YOUR LAWN

Fertilizing with a slow-release fertilizer provides missing nutrients which help create slow, even growth. While opinions vary on the need for fertilizing, when and how much to fertilize will be more a factor of the condition of the lawn and soil than any routine. Remember that over-fertilizing can cause harm, and that most fertilizing should be applied in the spring so that it will release into the lawn through the summer. For more information, check with a local nursery or lawn care specialist, and read and follow the fertilizer manufacturer's instructions.

AERATING YOUR LAWN

Consider aerating your lawn in spring. Using an aerator to remove cores of soil from the lawn increases the speed of clipping decomposition and encourages deeper root growth by opening up the soil and permitting greater movement of water, fertilizer and air.

Lawn Care & Mowing Information

HOW HIGH TO MOW THE GRASS

Often cutting height is a matter of personal preference. Typically, you should mow the grass when it is between three and five inches high. The proper cutting height range for a specific lawn will depend upon several factors, including the type of grass, the amount of rainfall, the prevailing temperature, and the lawn's overall condition.

Cutting the grass too short causes weak, thin grass plants, which are easily damaged by dry periods and pests. Cutting too short is often more damaging than allowing the grass to be slightly higher.

Letting grass grow a bit longer—especially when it is hot and dry—reduces heat build-up, preserves needed moisture and protects the grass from heat damage and other problems. However, allowing grass to grow too high can cause thin turf and additional problems.

Cutting off too much at one time shocks the plant's growth system and weakens the grass plants. **A good rule of thumb is the 1/3 rule: to cut no more than one third of the grass height, and never more than 1 inch at a time.**

The amount of grass you are able to cut in one pass is also effected by the type of mowing system you are using (for example, broadcasting with side discharge decks can process a much larger volume of grass than mulching does).

NOTE: We cover some specific mowing instructions for mulching and broadcasting later in this Lawn Care section.

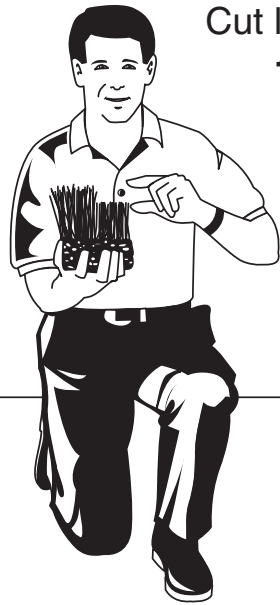

Cut less than
1/3

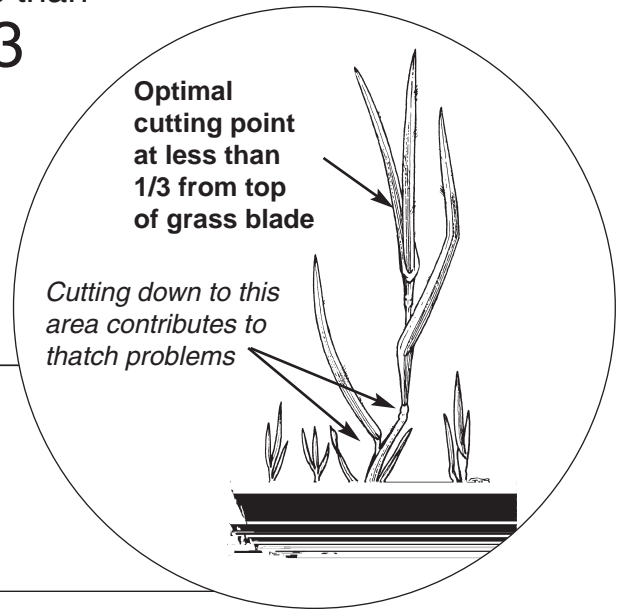

Proper Cutting Height

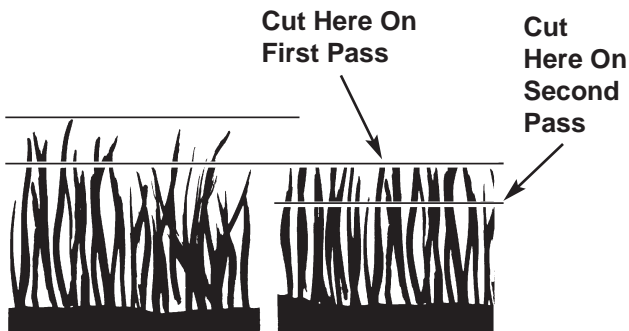

Tall Grass Requires Incremental Cutting

For extremely tall grass, set the cutting height at maximum for the first pass, and then reset it to the desired height and mow a second or third time.

Don't cover the grass surface with a heavy layer of clippings. Consider using a grass collection system and starting a compost pile.

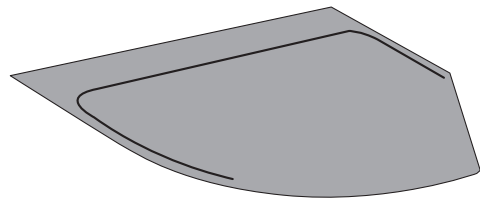

Lawn Care & Mowing Information

MOWING METHODS

Proper Broadcast Mowing

Broadcasting, or side-discharging, disperses fine clippings evenly over the entire lawn. Many golf courses use this method. Your mower has a deep dish deck to allow freer circulation of clippings so they are broadcast evenly over the lawn.

ENGINE SPEED & GROUND SPEED FOR BROADCASTING

Always operate the engine at full throttle when mowing. If you hear the engine slowing down, you are mowing too fast—using a slower ground speed will improve the cutting efficiency of the blades and prevents many common cutting problems.

ALWAYS use an appropriate ground speed for the thickness and height of the grass you are cutting (3rd gear or slower for manual gear models). If you hear the engine



slowing down you are mowing too fast, use a slower ground speed.

HOW MUCH GRASS TO CUT OFF WHEN BROADCASTING

Mow when the grass is 3-5 inches long. Do not cut the grass shorter than 2 to 2-1/2 inches. Do not cut off more than 1 inch of grass in a single pass.

Proper Mulching

Mulching consists of a mower deck which cuts and recuts clippings into tiny particles and which then blows them down INTO the lawn. These tiny particles decompose rapidly into by-products your lawn can use.

UNDER PROPER CONDI-

TIONS, your mulching mower will virtually eliminate noticeable clippings on the lawn surface.

NOTE: When mulching under heavy cutting conditions, a rumbling sound may be present and is normal.

MULCHING REQUIRES EXCELLENT MOWING CONDITIONS

Mulching mowers cannot function properly if the grass is wet, or if the grass is simply high to cut. Even more than normal mowing, mulching requires that the grass be dry and the appropriate amount is cut.

Do not use the mower as a mulching mower during the first two or three mowings in the spring. The long grass blades, quick growth, and often wetter conditions are more suitable for broadcasting (side-discharging) or grass bagging operation.

ENGINE SPEED & GROUND SPEED FOR BROADCASTING

Use full engine throttle matched with a slow ground speed so that clippings will be finely cut. Ground speed while mulching should be HALF of the speed that would be used when broadcasting (side discharging) under similar conditions. Since mulching requires more horsepower than broadcasting, using a slower ground speed is vitally important for proper mulching operation.

Mulching Action

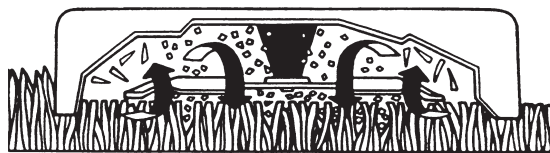

HOW MUCH GRASS TO MULCH

The best mulching action typically results from cutting only the top 1/2 inch to 3/4 inch of grass blade. This provides short clippings which decompose properly (much more quickly than longer clippings). The ideal cutting

height will vary with climate, time of year, and quality of your lawn. We recommend that you experiment with both the cutting height and ground speed until you achieve the best cut. Start with a high cutting height and using progressively lower settings until you find a cutting height that is matched to your mowing conditions and preferences.

TIPS On Dealing With Clippings

Clippings are **beneficial** to your lawn. A common misconception about clippings is that they automatically lead to thatch—this is untrue. Short clippings produced by broadcasting and clippings produced by mulching methods actually **contribute to a healthy lawn** because they:

- Reduce the evaporation of water from your lawn.
- Provide a cushioning layer to reduce lawn wear.
- Moderate soil temperature.
- Clippings act as a safe, non-polluting and inexpensive fertilizer that nourishes your lawn. Fresh cut grass blades are 85% water, and are a rich source of nitrogen which is essential to lush growth. And one garbage bag of clippings contains about 1/4 lb. of usable organic nitrogen.

COMPOSTING

The best way to recycle excess clippings and leave your lawn looking immaculate is to collect them with an efficient collection system and deposit them in a compost pile. A compost pile is a collection of grass, leaves, and other organic wastes which—when properly tended—decompose into an odorless, topsoil material. This material, in turn, acts as an inexpensive fertilizer for your lawn and garden.

How to start a healthy compost pile:

- 1 Build a bin using bricks, fencing, cement blocks, etc. or purchase a prefabricated bin from a garden store. The bin should also have venting on each side and from the bottom to the top.

- 2 Fill the bin with alternating layers of yard waste. Follow this recipe:

First layer: 3-4 inches of chopped brush or other coarse material.

Second layer: 6-8 inches of mixed leaves, grass clippings, sawdust, etc. Materials should be "sponge damp."

Third layer: 1 inch of soil to add micro-organisms that help break down organic matter.

Fourth layer: 1-2 inches of manure to provide the nitrogen needed by micro-organisms.

Keep adding layers until the bin is almost full. Top off with a 4-6 inch layer of straw and scoop out a "basin" to catch rain water.

- 3 Four or five days later the pile will reach temperatures of 140-160 degrees. At this time you'll notice it settling, a good sign your compost is working properly.
- 4 After 5-6 weeks, fork materials into a new pile, turning the outside of the old heap into the center of the new one. Add water if necessary. The compost should be ready to use within three to four months when dark brown, crumbly, and earthy-smelling.



Stepped Cutting

Stepped cutting is sharp ridges or uneven levels left in the lawn surface. Stepped cutting is usually caused by mower deck damage or misadjustment, or damage to mower blades.

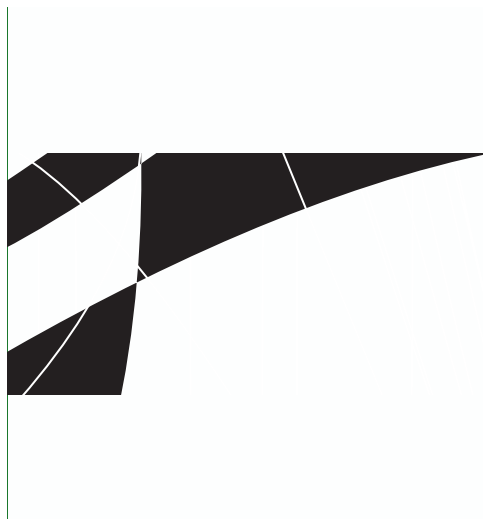

CAUSE

- Deck is not leveled correctly
- Tires are not properly inflated
- Blades are damaged
- Deck shell is damaged
- Mower spindle is bent or loose
- Blades are installed incorrectly

SOLUTION

- Level the deck correctly
- Check and inflate the tires
- Replace the blades
- Repair or replace the deck
- Repair or replace the spindle
- Reinstall the blades correctly

Uneven Cutting

Uneven cutting is waviness or srr lawn surface. Uneven cutting is mower deck damage or misadju

CAUSE

- Deck is not leveled correctly
- Blades are dull or worn
- Blades are damaged
- Deck is clogged with grass clip
- Deck shell is damaged
- Mower spindle is bent or loose
- Blades are installed incorrectl

Stingers

Stingers are sparse patches of uncut grass left behind the mower. Stingers are usually caused by operator error or poor blade maintenance.

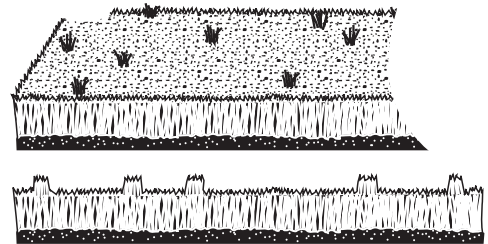









CAUSE

- Blades are not sharp or are nicked
- Blades are worn down too far
- Engine speed is too slow
- Ground speed is too fast
- Deck is plugged with grass

SOLUTION

- Sharpen your blades
- Replace your blades
- Always mow at full throttle
- Slow down
- Clean out the mower

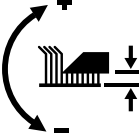
Common International Symbols

- | | | | |
|---|-----------------|---|---------------------------------|
|  | Choke |  | PTO Clutch |
|  | Fast (Throttle) |  | Parking Brake |
|  | Slow (Throttle) |  | Brake |
|  | Throttle |  | Mower Cutting Height Adjustment |
|  | Fuel |  | Headlights |

Technical Manuals

Additional Technical Literature Available



Operators Manuals

Additional copies of this manual are available, (and as part of our product support commitment, we maintain a stock of printed operators manuals going back many years!)

Parts Manuals

Fully illustrated parts manuals are also available — these manuals show all of the product's components in exploded views ("3D" illustrations which show the relationship of the parts and how they go together), as well as giving the replacement part numbers and quantities used. Important assembly notes and special torque values are included in these manuals.

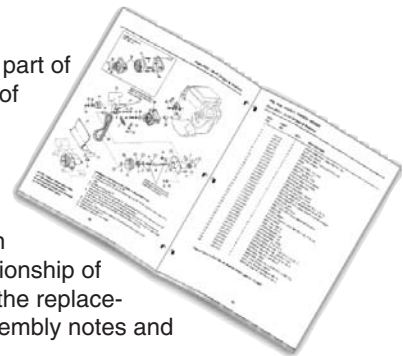

For the applicable manuals currently available for your model, contact your local dealer. Have the information listed in the box at the right available when making your request.

Model:	_____
Serial No.:	_____
Your Name:	_____
Address:	_____
City, State, Zip:	_____
Visa/Mastercard No.:	_____
Card Expiration Date:	_____

Ferris Industries, Inc.
Owner's Limited Warranty Information

(Effective 04/28/2004)

Thank you for purchasing Ferris commercial mowing equipment. Please take a few minutes to read this limited warranty information. It contains all the information you will need to have your Ferris mower repaired in the unlikely event that a breakdown covered by this limited warranty should occur.

Owner's Responsibilities - As a condition to our obligations under this limited warranty, you shall have read the operator's manual and you shall have completed and submitted to Ferris, within 20 days from the date of purchase, the Ferris Product Registration. You must properly service and maintain your Ferris product as described in the operator's manual. Such routine maintenance, whether performed by a dealer or by you, is at your expense. The Ferris equipment, including any defective part covered by this limited warranty, must be returned to an authorized Ferris dealer within the warranty period for warranty service. This limited warranty extends only to equipment operated under normal conditions and in accordance with Ferris' instructions.

Warranty Start Date - The limited warranty coverage begins on the day you buy your new Ferris commercial mowing equipment. An authorized Ferris dealer will assist you in filling out a Ferris Product Registration with specific information for the model you purchase and your personal information, which must be returned to Ferris.

Limited Warranty - The limited warranty, set forth below, is a written guarantee by Ferris, during the warranty period, to repair or replace parts which have a substantial defect in materials or workmanship. The warranty is "limited" because it is for a specified period of time, applies to the original purchaser only, and is subject to other restrictions.

FERRIS LIMITED WARRANTY

Ferris Industries, Inc. (Ferris) warrants, in accordance with the provisions below, to the original purchaser only, for the periods described below that the commercial mower shall be free from substantial defects in material or workmanship under normal use and service. If you wish to file a claim under this limited warranty, you must provide prompt notice of your claim to an authorized Ferris dealer during the warranty period. Ferris' obligation under this limited warranty is, at Ferris' option, to repair or replace any part or parts of the mower, which, in the judgment of Ferris, are found to be defective and covered by this limited warranty. An authorized Ferris dealer will repair or replace the defective part or parts, at the dealer's place of business, at no charge for the labor or parts. This limited warranty applies only to mowers sold in the United States and Canada and is subject to the following limitations.

Covered Parts

All Mowers

Warranty Period

2-years (24 months) from date of retail purchase by the original purchaser for parts & labor (90 days for rental mowers)
(Except as noted below*)

*Belts, Tires, Brake Pads
And Hoses, Battery, Blades

90 days from date of retail purchase by the original purchaser

*Attachments

1 year from date of retail purchase by the original purchaser

*Engine

If the engine manufacturer provides any warranty on the mower's engine, Ferris will assign that warranty to the original purchaser of the mower if such assignment is reasonably practicable. Please refer to the engine manufacturer's warranty statement, if any, that is included in the owner's packet. We are not authorized to handle warranty adjustments or repairs on engines. Ferris offers **NO WARRANTY** on mower engines. Ferris does not guarantee or represent that any engine manufacturer will comply with the terms of its warranty.

Items and Conditions Not Covered

This warranty does not cover, and Ferris makes **NO WARRANTY** regarding, the following:

- Mowers or their parts if a complete and accurate Ferris Product Registration has not been received by Ferris.
- Loss or damage to person or property other than that expressly covered by the terms of this limited warranty.
- Pickup and delivery charges and risk of loss or damage in transit to and from any authorized Ferris dealer.
- Any damage or deterioration due to normal use, wear and tear, or environmental or natural elements, or exposure.
- Cost of regular maintenance service or parts, such as but not limited to, filters, fuel, lubricants, tune-up parts, and adjustments.
- Claims arising due to failure to follow Ferris' written instructions, or improper storage or maintenance.
- Any repairs necessary due to use of parts, accessories or supplies, including gasoline, oil or lubricants, incompatible with the mowing equipment, or other than as recommended in the operator's manual or other written operational instructions provided by Ferris.
- Use of non-Ferris approved parts or accessories.
- Any overtime or other extraordinary repair charges or charges relating to repairs or replacements.
- Rental of like or similar replacement equipment during the period of any warranty, repair or replacement work.
- Loss of revenue, time or use of the mowing equipment.
- Travel, telephone or other communication charges.
- Damage from continued use of defective mowing equipment.
- Freight charges on replacement parts.
- Any mowing equipment or part which, in the judgment of Ferris, has been altered or tampered with in any way or has been subjected to misuse, abuse, abnormal usage, unauthorized repair, neglect or accident, damage in transit, or has had the serial numbers altered, effaced or removed.
- Any equipment, part or item not mentioned under "Covered Parts," above.

General Conditions

Ferris is continually striving to improve its products, and therefore reserves the right to make improvements or changes without incurring any obligation to make changes or additions to products sold previously. Any oral or written description of Ferris products is for the sole purpose of identifying the products and shall not be construed as an express warranty. No warranty claim shall give rise to a right for the purchaser to cancel or rescind any sale. No person is authorized to make any warranty or assume for Ferris any liability not strictly in accordance with this limited warranty. Any assistance Ferris provides to or procures for the purchaser outside the terms, limitations or exclusions of this limited warranty will not constitute a waiver of the terms, limitations or exclusions of this limited warranty, nor will such assistance extend or revive the limited warranty. Ferris will not reimburse the purchaser for any expenses incurred by the purchaser in repairing, correcting or replacing any defective products except for those incurred with Ferris' prior written permission and in accordance with this limited warranty.

Ferris' sole and exclusive liability with respect to this limited warranty, and the purchaser's exclusive remedy, shall be repair or replacement as set forth herein. All warranty work must be performed by an authorized Ferris dealer using only Ferris approved replacement parts. **FERRIS SHALL HAVE NO LIABILITY FOR ANY OTHER COST, LOSS OR DAMAGE, INCLUDING BUT NOT LIMITED TO, ANY INCIDENTAL, COMPENSATORY, INDIRECT, PUNITIVE, SPECIAL OR CONSEQUENTIAL LOSS OR DAMAGE. FERRIS' AGGREGATE LIABILITY WITH RESPECT TO A DEFECTIVE PRODUCT OR PART SHALL BE LIMITED TO AN AMOUNT EQUAL TO THE MONIES PAID BY THE PURCHASER FOR THAT DEFECTIVE PRODUCT OR PART. THIS LIMITED WARRANTY, AND FERRIS' OBLIGATIONS HEREUNDER, ARE EXCLUSIVE AND IN LIEU OF ALL OTHER WARRANTIES, EXPRESS OR IMPLIED, INCLUDING, WITHOUT LIMITATION, THE IMPLIED WARRANTY OF MERCHANTABILITY AND THE IMPLIED WARRANTY OF FITNESS FOR A PARTICULAR PURPOSE. FERRIS SHALL NOT BE LIABLE TO THE PURCHASER, OR TO ANYONE CLAIMING UNDER THE PURCHASER, FOR ANY OTHER OBLIGATIONS OR LIABILITIES, INCLUDING, BUT NOT LIMITED TO, OBLIGATIONS OR LIABILITIES ARISING OUT OF BREACH OF CONTRACT OR WARRANTY, NEGLIGENCE OR OTHER TORT OR ANY THEORY OF STRICT LIABILITY, WITH RESPECT TO FERRIS PRODUCTS OR FERRIS' ACTS OR OMISSIONS OR OTHERWISE.**

It is the express wish of the parties that this agreement and any related documents be drafted in English. Il est la volonté expresse des parties que cette convention et tous les documents s'y rattachent soient rédigés en anglais.

OPERATOR'S MANUAL

IS4500Z Series

Zero-Turn Riding Mower



Ferris Industries
5375 North Main Street
Munnsville, NY 13409
800-933-6175

www.ferrisindustries.com

© Copyright 2005 Ferris Industries
All Rights Reserved. Printed in USA.



Free Manuals Download Website

<http://myh66.com>

<http://usermanuals.us>

<http://www.somanuals.com>

<http://www.4manuals.cc>

<http://www.manual-lib.com>

<http://www.404manual.com>

<http://www.luxmanual.com>

<http://aubethermostatmanual.com>

Golf course search by state

<http://golfingnear.com>

Email search by domain

<http://emailbydomain.com>

Auto manuals search

<http://auto.somanuals.com>

TV manuals search

<http://tv.somanuals.com>