

Fisher & Paykel

Freestanding cooker

OR90SBDSIX models

**Installation instructions
and User guide**

Safety and warnings	2
Installation instructions	8
First use	16
Using your oven	19
Cooking functions	22
Cooking guide	25
Using the rotisserie	26
Using the electronic timer	28
Automatic cooking	29
Induction cooktop introduction	30
Choosing the right cookware	32
Using your induction cooktop	34
Using your cooktop's special features	35
Cooking guidelines	37
Care and cleaning	38
Cooktop fault codes	52
Troubleshooting	52
Warranty and service	55

Important!

SAVE THESE INSTRUCTIONS

The models shown in this User Guide may not be available in all markets and are subject to change at any time. For current details about model and specification availability in your country, please go to our website www.fisherpaykel.com or contact your local Fisher & Paykel dealer.

2 Safety and warnings

Installation

! WARNING!



Electrical Shock Hazard

If the ceramic glass cooktop surface becomes cracked, switch the appliance off at the mains power supply and call an Authorised Service Agent.

Always disconnect the cooker from the mains electricity supply before carrying out any maintenance operations or repairs.

Failure to follow this advice may result in death or electrical shock.

! WARNING!



Cut Hazard

Take care - panel edges are sharp.

Failure to use caution could result in injury or cuts.

Important safety instructions

General

- *To avoid hazard, follow these instructions carefully before installing or using this product.*
- *Please make this information available to the person installing the product as it could reduce your installation costs.*
- *Installation must comply with your local building and electricity regulations.*
- *Failure to install the cooker correctly could invalidate any warranty or liability claims.*
- *Some appliances have a protective film. Remove this film before using the cooker.*
- *Do not modify this appliance.*
- *Do not operate your appliance by means of an external timer or separate remote-control system.*
- *This appliance is to be installed and serviced only by an authorised person.*
- *User servicing: do not repair or replace any part of the appliance unless specifically recommended in the manual. All other servicing should be referred to a qualified technician.*
- *Do not install or operate the appliance if it is damaged or not working properly. If you receive a damaged product, contact your dealer or installer immediately.*

Electrical

- *This cooker is to be installed and connected to the electricity supply only by an authorised person.*
- *If the installation requires alterations to the domestic electrical system, call a qualified electrician. The electrician should also check that the electrical system is suitable for the electricity drawn by the cooker.*
- *The appliance must be connected to the mains electricity supply, checking that the voltage corresponds to the value given in the rating plate and that the electrical cable sections can withstand the load specified on the plate.*
- *A suitable disconnection switch must be incorporated in the permanent wiring, mounted and positioned to comply with the local wiring rules and regulations. The switch must be of an approved type installed in the fixed wiring and provide a 3 mm air gap contact separation in all poles in accordance with the local wiring rules.
In Australia and New Zealand, a switch of the approved type with a 3 mm air gap must be installed in the active (phase) conductor of the fixed wiring.*
- *The switch must always be accessible.*
- *The power supply cable must not touch any hot parts and must be positioned so that it does not exceed 75 °C at any point.*
- *To connect the cooker to the mains electricity supply, do not use adapters, reducers or branching devices as they can cause overheating and burning.*
- *This cooker must be connected to a suitable double pole control unit adjacent to the cooker. No diversity can be applied to this control unit.*
- *If the electrical supply cord is damaged, it must only be replaced by an authorised person.*
- *In Australia and New Zealand: this cooker must be connected to electrical supply using V105 insulated cable.*
- *In New Zealand, this appliance must be connected to the electrical supply using a cable fitted with an appropriately rated plug. The plug must be compatible with the socket-outlet fitted to the final subcircuit in the fixed wiring that is intended to supply the appliance.*
- *In United Kingdom and Ireland: this cooker must be connected to electrical supply using H05RR-F or H05VV-F insulated cable.*
- *The cooker must be earthed.*

OR90SDBSIX2 220-240/380-415 V 3N~, 11080 W (*), 50/60 Hz 48,17 A (230 V) (*)

(*) diversity not applied

Operation

Your freestanding cooker has been carefully designed to operate safely during normal cooking procedures. Please keep the following guidelines in mind when you are using it:

WARNING!



Explosion Hazard

Do not store flammable materials such as gasoline near the cooktop.
Do not store flammable material in the oven or storage compartment.
Do not spray aerosols near the cooktop during use.

Failure to follow this advice may result in death or serious injury.

WARNING!



Electrical Shock Hazard

Switch the cooker off at the wall before replacing fuses or the oven lamp.
If the cooktop surface is cracked, switch the appliance off at the wall. Contact an accredited service provider to repair it, and do not use until it has been repaired.

Failure to do so may result in death or electrical shock.

! WARNING!



Health Hazard

This appliance complies with electromagnetic safety standards. However, persons with cardiac pacemakers or other electrical implants (such as insulin pumps) must consult with their doctor or implant manufacturer before using this appliance to make sure that their implants will not be affected by the electromagnetic field.

Failure to follow this advice may result in death.

! WARNING!



Hot Surface Hazard

Accessible parts may become hot when this cooker is in use.

To avoid burns and scalds keep children away.

Do not let body, clothing or any item other than suitable cookware contact with the ceramic glass until the surface is cool.

Never leave metal objects (such as kitchen utensils) or empty pans on the cooktop as they can become hot very quickly.

Beware: magnetisable metal objects worn on the body may become hot in the vicinity of the cooktop. Gold or silver jewellery will not be affected.

Keep children away.

Handles of saucepans may be hot to touch. Check saucepan handles do not overhang other cooking zones that are on. Keep handles out of reach of children. Do not touch hot surfaces inside the oven.

Use oven mitts or other protection when handling hot surfaces such as oven shelves or dishes.

Take care when opening the oven door.

Let hot air or steam escape before removing or replacing food.

Do not touch the cooktop components, burners, trivets/pan supports or the base when hot.

Before cleaning, turn the cooker off and make sure it is cool.

Failure to follow this advice could result in burns and scalds.

Important safety instructions

- *Never leave the appliance unattended when in use. Boilover causes smoking and greasy spillovers may ignite.*
- *NEVER try to extinguish a fire with water, but switch off the appliance and then cover flame eg with a lid or a fire blanket.*
WARNING: Danger of fire: do not store items on the cooking surfaces. Do not use your cooktop as a work surface.
- *Do not use a steam cleaner on any part of your cooker.*
- *Isolating switch: make sure this cooker is connected to a circuit which incorporates an isolating switch providing full disconnection from the power supply.*
- *Household appliances are not intended to be played with by children. Do not store things children might want above the oven. Children could be burned or injured while climbing on the oven to retrieve items.*
- *Children of less than 8 years old must be kept away from the appliance unless continuously supervised. This appliance can be used by children aged from 8 years and above, and persons with reduced physical, sensory or mental capabilities or lack of experience and knowledge, if they have been given supervision or instruction concerning the use of the appliance in a safe way and they understand the hazards involved. Cleaning and user maintenance shall not be done by children without supervision.*
- *Safe food handling: leave food in the oven for as short a time as possible before and after cooking. This is to avoid contamination by organisms which may cause food poisoning. Take particular care during warmer weather.*
- *If the electrical supply cord is damaged, it must only be replaced by an authorised person. This cooker is not to be used as a space heater, especially if it is installed in marine craft or in a caravan.*

Operation

- *Do not place aluminium foil, dishes, trays, water or ice on the oven floor during cooking as this will irreversibly damage the enamel.*
- *Do not line the walls with aluminium foil. Do not stand on the door, or place heavy objects on it.*
- *Do not place or leave any magnetisable objects (eg credit cards, memory cards) or electronic devices (eg computers, MP3 players) near the appliance, as they may be affected by its electromagnetic field.*
- *We recommend using plastic or wooden kitchen utensils for cooking with your induction cooktop.*
- *After use, always turn off the cooking zones. Do not rely on the pan detection feature to turn off the cooking zones when you remove the pans.*
- *Do not place or drop heavy objects on your cooktop.*
- *Do not stand on your cooktop. Do not use pans with jagged edges or drag pans across the ceramic glass surface as this can scratch the glass.*

Important safety instructions

- *Do not use harsh abrasive cleaners or sharp metal scrapers to clean the ceramic glass cooktop and the oven door glass since they scratch the surface, which may result in shattering of the glass. Some heavy-duty and nylon scourers can scratch the ceramic glass cooktop. Always read the label to check if your scourer is suitable for cleaning ceramic glass cooktops.*
- *Do not use pans with rough circular base as these may scratch your cooktop.*
- *Wear proper apparel. Do not wear loose fitting or hanging garments when using the appliance. They could ignite or melt if they touch an element or hot surface and you could be burned.*
- *Always keep oven vents unobstructed*
- *Use only dry oven mitts or potholders. Moist or damp potholders on hot surfaces could result in burns from steam. Do not let potholders touch hot areas or heating elements. Do not use a towel or a bulky cloth for a potholder. It could catch fire.*
- *Caution. Hot air can blow from the vent at the top of the oven as part of the oven's cooling system.*
- *Placement of oven shelves: always position shelves in the desired location while the oven is cool (before preheating). If a shelf must be removed while the oven is hot, do not let the oven mitts or potholder contact hot heating elements in the oven or the base of the oven.*

Dimensions and clearances

- The cooker must be installed no less than 50 mm away from any side walls which exceed the height of the cooktop.
- The cabinetry surrounding the cooker must be made of heat-resistant material and must be able to withstand temperatures of 65 °C above room temperature.
- Do not install the cooker near flammable materials (eg curtains).
- If you stand the cooker on a pedestal, make sure you provide safety measures to keep it in place.

Locating the area for electrical connection

Dotted line showing the position of the cooker when installed

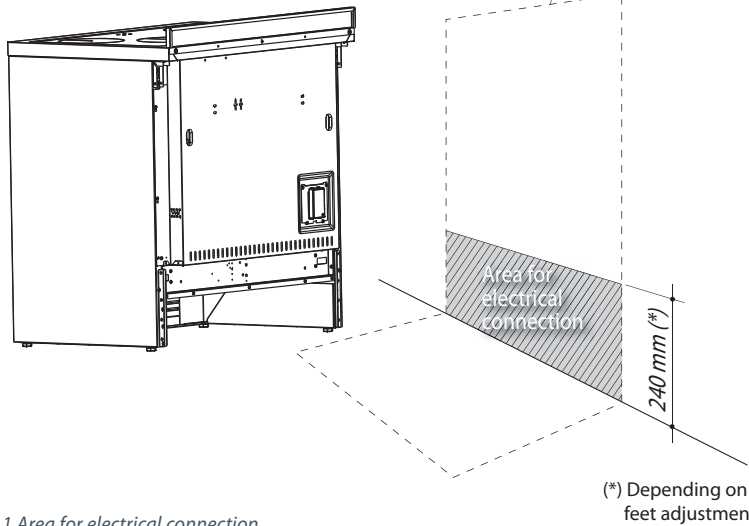

Fig. 1 Area for electrical connection

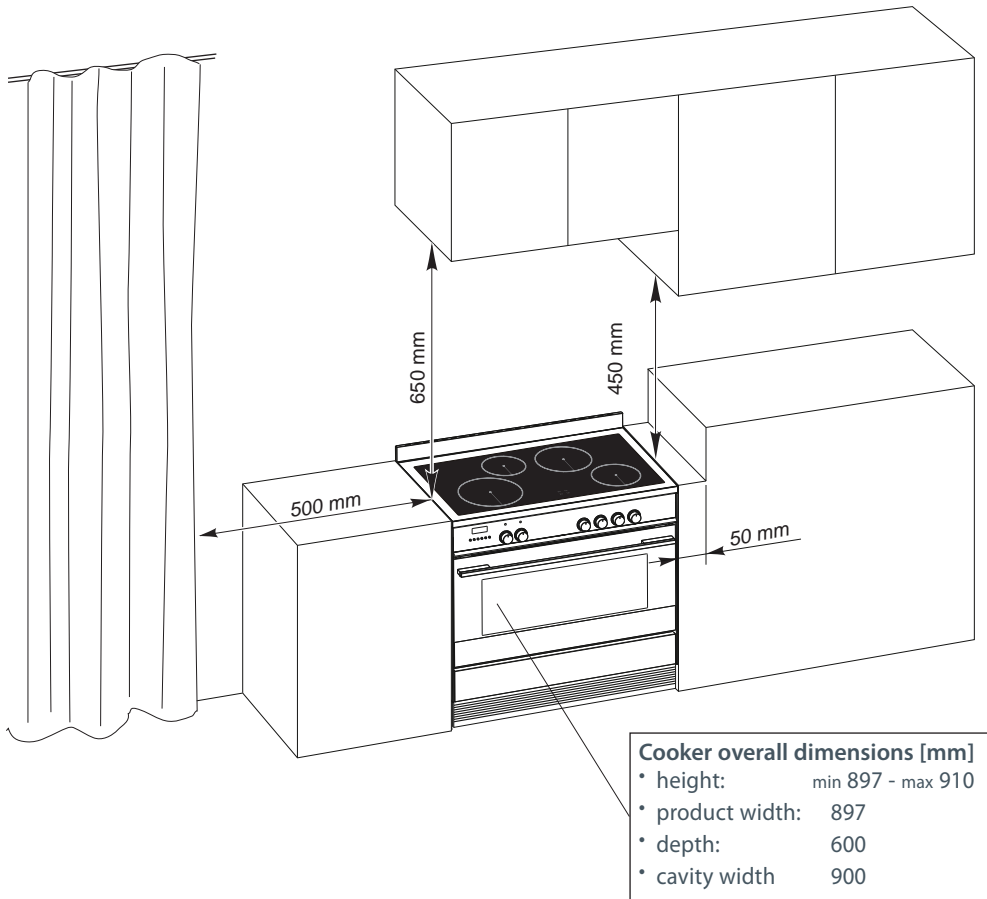

Fig. 2 Dimensions and distances from cooker

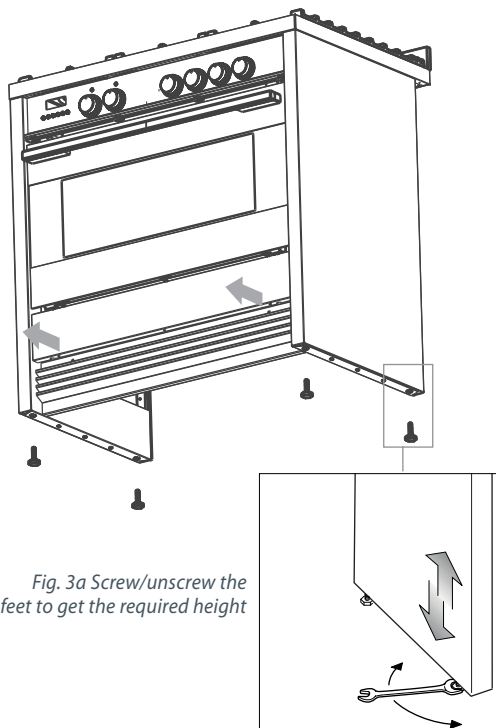

Fig. 3a Screw/unscrew the feet to get the required height

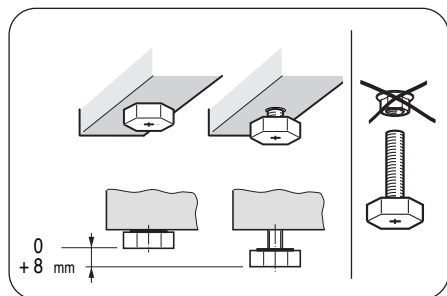

Fig. 3b Do not use the supplied nuts for height adjustments between 0 and 8 mm

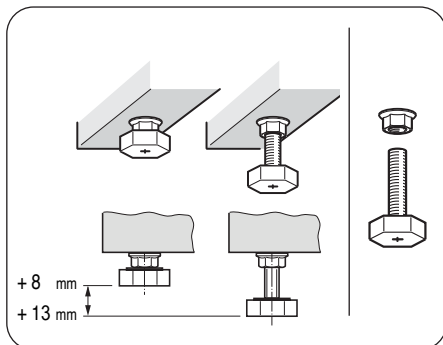

Fig. 3c Use the supplied nuts for height adjustments between 8 and 13 mm

Levelling the cooker

Important!

Using the supplied adjustable feet is **MANDATORY**. For safety reasons and to ensure adequate ventilation, the cooker chassis **MUST NOT** sit directly on the floor, a plinth, or other support surface.

- For ease of installation, first remove the kickstrip. To remove the kickstrip, unscrew the two screws holding it in place.
- The cooker is already fitted with four levelling feet.
- Level the cooker by screwing or unscrewing the feet.
- Make sure you follow the instructions in Figs. 3a, 3b, and 3c.
- Note: nuts are supplied with the cooker in a separate kit.

Do not refit the kickstrip until you have installed the anti-tip bracket.

Fitting the anti-tilt bracket

Important!

To restrain the appliance and prevent it tipping accidentally, the anti-tilt bracket and restraining plate supplied must be fitted according to the instructions below.

- 1 Drill four 8mm diameter holes for the fixing screws (two in the wall and two in the floor-see Fig.4) and insert the plastic plugs supplied.

Important!

Before drilling the holes, check that you will not damage any pipes or electrical wires.

- 2 Attach the anti-tilt bracket to the floor and rear wall using the four screws supplied, as shown in Fig. 4.
- 3 After attaching the anti-tilt bracket securely, slide the cooker into place. Ensure that the left rear foot slides under the bracket, as shown in Fig.4.
- 4 Access the bracket by removing the drawer (Fig. 5):

- a Slide out the drawer completely.
- b Press the lever of the left guide rail down and pull the lever of the right guide rail up.
- c Holding the levers, disengage and remove the drawer.

- 5 If fitted, remove the kickstrip (see 'Levelling the cooker'). Fix the restraining plate by sliding it into place and securing it with the fixing screw and washer supplied. See Fig. 6.

- 6 Replace the drawer (Fig. 7):

- a Insert the drawer rails into the guide rails.
- b Gently push the drawer in completely; the safety catches will automatically hook.

- 7 Replace the kickstrip using the two screws.

Important!

Beware of sharp edges when removing or replacing the drawer.

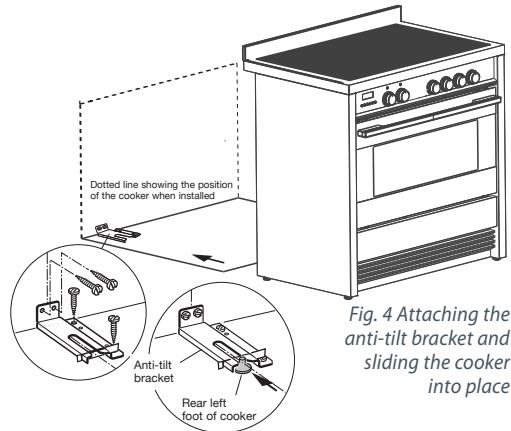

Fig. 4 Attaching the anti-tilt bracket and sliding the cooker into place

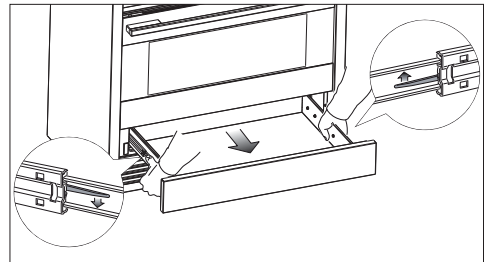

Fig. 5 Accessing the anti-tilt bracket by removing the drawer

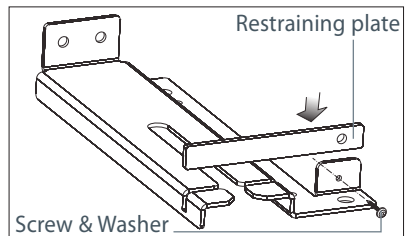

Fig. 6 Fixing the restraining plate

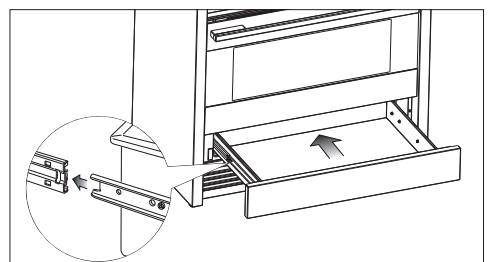

Fig. 7 Replacing the drawer

Moving the cooker

Important!

To prevent damaging the adjustable feet or lower trim, ensure the cooker is always lifted by two people.

Do not lift the cooker by the door handles.
DO NOT DRAG the cooker. Lift the feet clear of the floor.

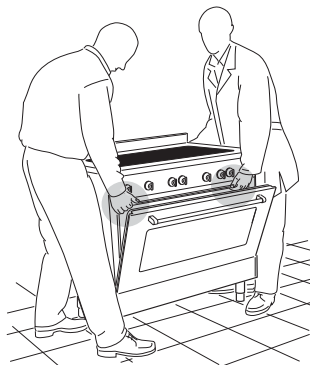

Fig. 8 Correctly lifting the cooker

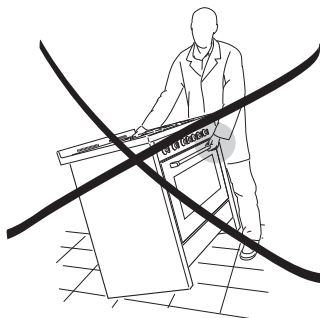

Fig. 9 Incorrectly lifting the cooker



Fig. 10 Incorrectly moving the cooker

Fixing the backguard

Before installing the cooker, assemble the backguard "C".

- The backguard "C" can be found packed at the rear of the cooker.
- 1 Before assembling, remove any protective film/adhesive tape.
 - 2 Remove the two spacers "A" and the screw "B" from the rear of the cooktop.
 - 3 Assemble the backguard as shown and fix it by screwing the central screw "B" and the spacers "A".

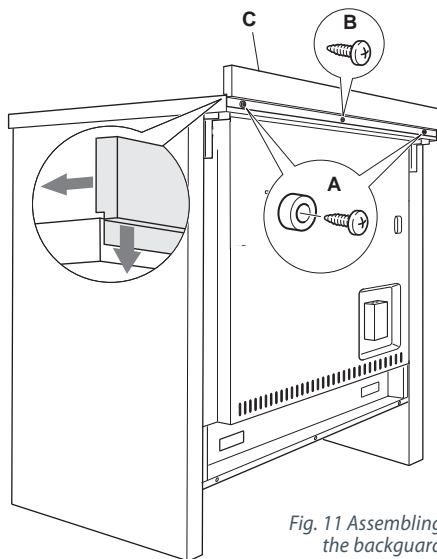

Fig. 11 Assembling the backguard

Connecting the power supply cable

Important!

This cooker must be connected to the electricity supply only by an authorised person.

To connect the power supply cable to the cooker, it is necessary to:

- 1 Unhook the terminal board cover by inserting a screwdriver into the two hooks 'A' (fig. 12).
- 2 Unscrew the screw 'D' and open completely the cable clamp 'E' (figs. 14).
- 3 Position the U bolts 'F' onto terminal board 'G' (figs. 14) according to the diagrams in fig. 13.
- 4 Connect the phase, neutral and earth wires to terminal board 'G' according to the diagrams in figs. 13 - 14.
- 5 Strain the feeder cable and block it with cable clamp 'E' (by screwing screw 'D').
- 6 Close the terminal block cover (check the two hooks 'A' are correctly hooked).

Important!

To connect the power supply cable DO NOT unscrew the screws fixing the cover plate behind the terminal block.

WARNING: *If the power supply cable is damaged, it must be replaced only by an authorised service agent in order to avoid a hazard.*

Voltage and power consumption

220-240/380-415 V 3N~ 50/60 Hz 48,17 A (230 V) 11080 W (diversity not applied)

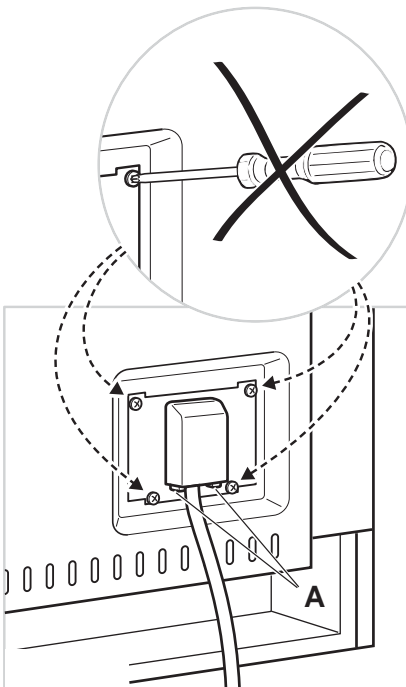

Fig. 12 Terminal block

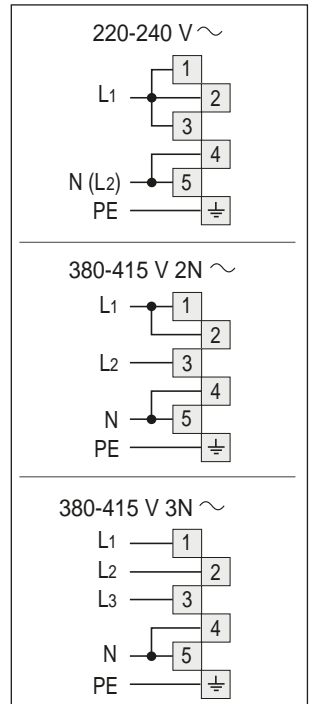

Fig. 13 Connection diagrams

Feeder cable section

- *In Australia and New Zealand: this cooker must be connected to electrical supply using V105 insulated cable.*

220-240 V~	3 x 6 mm ² (*)
380-415 V 3N~	5 x 2,5 mm ² (*)
380-415 V 2N~	4 x 6 mm ² (*)

* Connection with wall box connection.

- Diversity factor applied.

- A diversity factor may be applied to the total loading of the appliance only by a suitably qualified person.

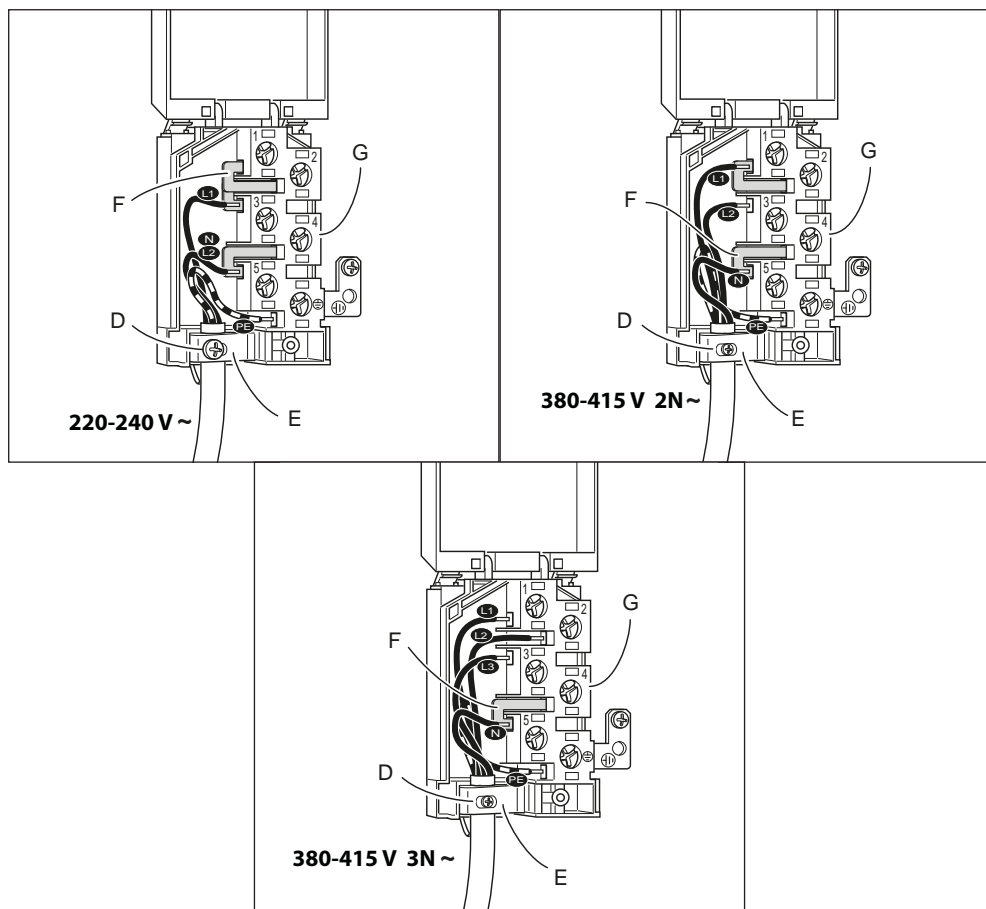
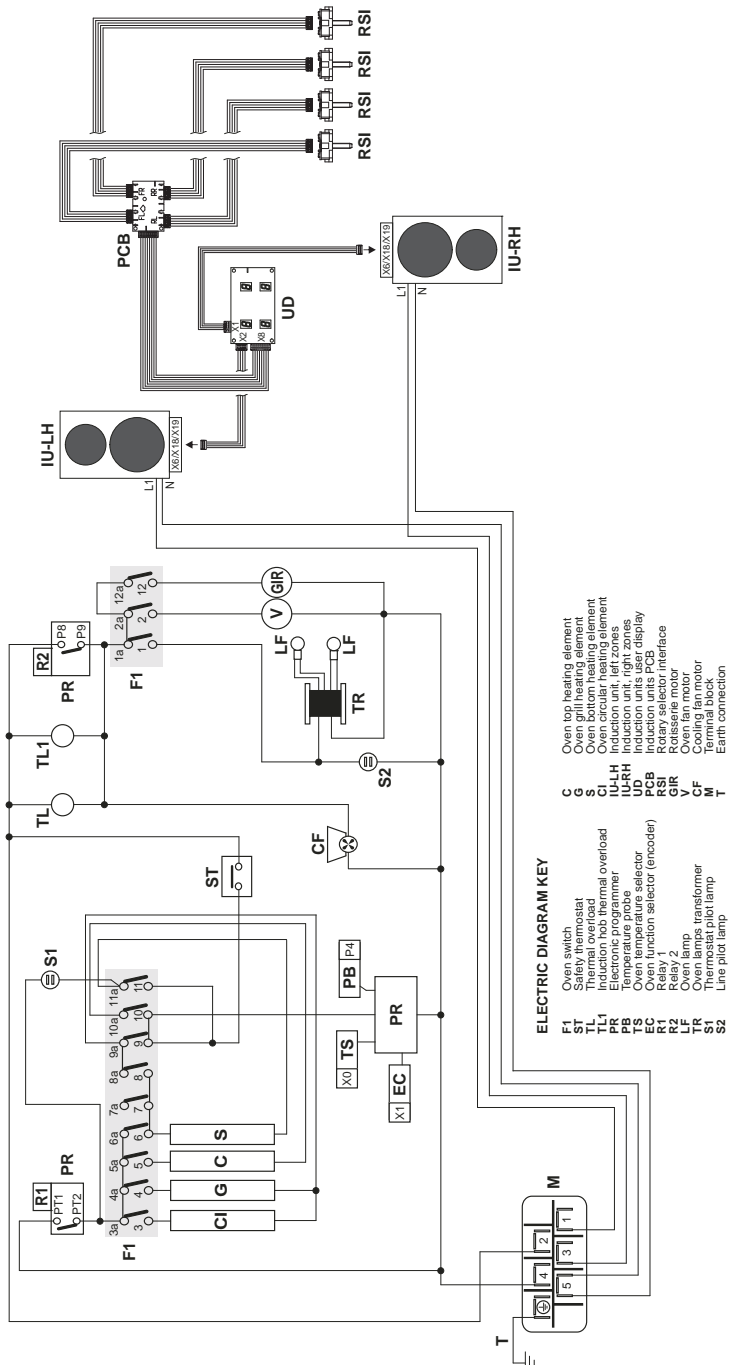

Fig. 14 Connection diagrams

Wiring diagram



16 First use

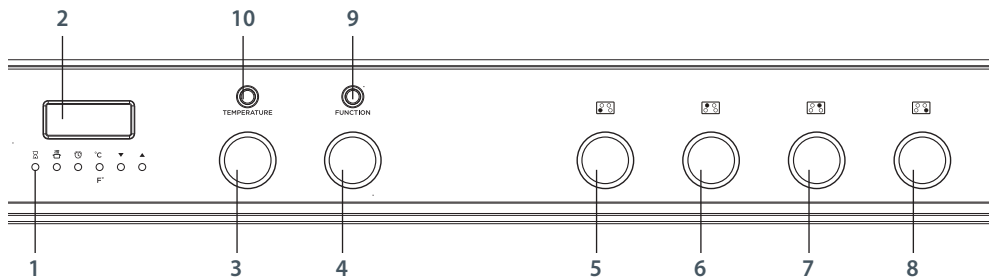





Fig. 15 Control panel

- | | | | |
|---|------------------------------|----|-------------------------------|
| 1 | Control buttons | 7 | Rear right cooking zone dial |
| 2 | Clock display | 8 | Front right cooking zone dial |
| 3 | Temperature dial | 9 | Function indicator light |
| 4 | Function dial | 10 | Temperature indicator light |
| 5 | Front left cooking zone dial | | |
| 6 | Rear left cooking zone dial | | |

Buttons

-  sets the timer
-  sets the cooking time
-  sets the stop time for automatic cooking
- °C set the oven temperature /
- F° select Celsius or Fahrenheit
- ▼ decreases the time and temperature
- ▲ increases the time and temperature

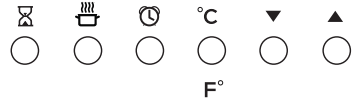







Fig. 16 Clock display and control buttons

Illuminated symbols



If the display shows	It means that...	For more information
flashing 12:00	The clock needs to be set.	See instructions below.
A steadily lit	The oven is set for automatic cooking.	See section 'Automatic cooking'
flashing and beeping	Automatic cooking has finished	
 steadily lit	The timer is set	See section 'Using the electronic timer'
 steadily lit	The oven is heating up	See section 'Using your oven'

To set the clock

When the power to the appliance is turned on or restored after a power failure 12:00 will flash in the display.

- 1 Press  and  together - the display will stop flashing. The clock is now set for 12:00.
- 2 Press  and  together again to change the time. The display will flash
- 3 Press ▼ and ▲ to set the time. After a few minutes the display will be steadily lit, showing the time is set.

To change the time

- 1 Press  and  together. The display will flash.
- 2 Press ▼ and ▲ to set the time.

After a few seconds the display will remain steadily lit, showing the time is set.

Remove the side racks to fit the Catalytic panels (if not already fitted)

- 1 Remove all shelves and trays.
- 2 For easier access to the fixing screws, you may remove the oven door first. See 'Removing and refitting the oven door' in Care and Cleaning.
- 3 Remove the side racks on both sides:
 - 3a Using a small coin or a flat-head screwdriver, loosen and remove both fixing screws.
 - 4a Gently remove the side rack.

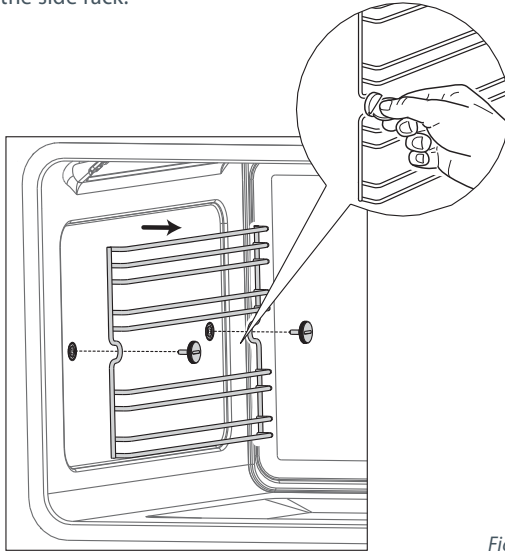

Fig. 17 Removing the side racks



Fitting the Catalytic panels

- 5 Fit the catalytic panel. When fitting the catalytic panel make sure that
 - the arrows are pointing upwards
 - the panel with the hole in it is on the right oven wall.

Refitting the side racks

- 6 To refit the side racks
 - make sure that they are the right way up, as in the illustrations, and that you tighten the fixing screws.
- 7 If not already fitted, fit the telescopic sliding shelf supports. See "Care and cleaning" for instructions.

Before using your new oven, please:

- 1 Read this user guide, taking special note of the 'Safety and warnings' section.
- 2 Remove all accessories and packaging. Peel the protective film off all surfaces and accessories.
- 3 Set the clock. The oven will not work until the clock has been set. See 'Setting the clock'.
- 4 Fit the Catalytic panels and side racks. See 'Fitting the Catalytic panels'.
- 5 If not already fitted, fit the sliding shelf supports. See 'Care and cleaning' for instructions.
- 6 Slide in the shelves you will need, making sure that:
 - they are between the two wires of a shelf position;
 - the stop notches point down;
 - the guard rail is at the back.
 - Note: the grill tray should be positioned between the two wires of a shelf position and orientated as shown.
- 7 Heat the oven on maximum for:
 - 60 minutes in the  position
 - 30 minutes in the  position
 - 15 minutes in the  position
 - There will be a distinctive smell while you are conditioning your oven. This is normal, but make sure your kitchen is well ventilated during the conditioning.
- 8 Once cooled, wipe out the oven with a damp cloth and mild detergent, and dry thoroughly.

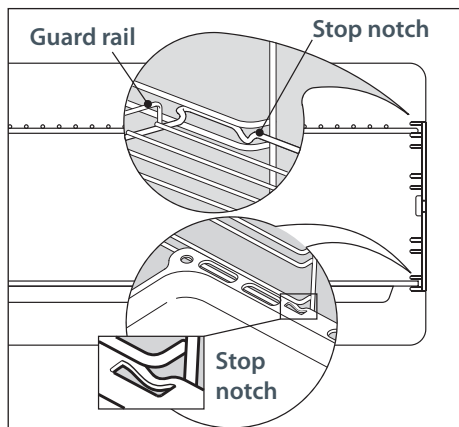

Fig. 18 Correct position of shelves and grill tray

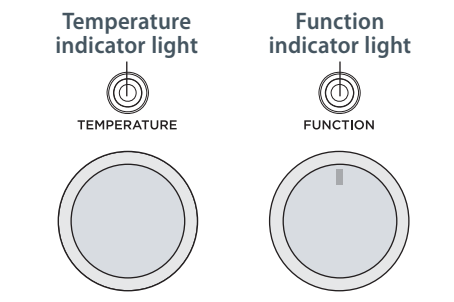
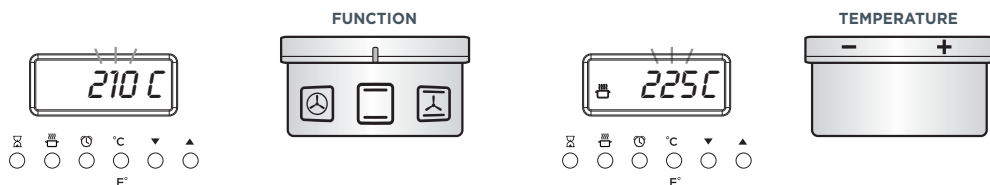

Fig. 19 Function and temperature dials





1 Select a function

Rotate the function dial to select a function

- The function indicator light will come on.
- The preset function temperature will flash in the display. (Each cooking function has a preset temperature)

If you wish to use the oven at the preset temperature -

- After a few seconds, the display will stop flashing and the oven will turn on and heat up. The display will revert to show the actual oven temperature.
- The  indicator will show in the display.

Note: if you select , the display will show *DEF*. The temperature cannot be adjusted when using this function.

2a Adjust the temperature

There are two ways to set the temperature while the display is flashing:



- Rotate the temperature dial (clockwise to increase and anticlockwise to decrease the temperature);
- OR**
- Use the ▼ and ▲ buttons to increase or decrease the set temperature.
- After a few seconds, the display will stop flashing and the oven will turn on and heat up. The display will revert to show the actual oven temperature.
- The  indicator will show in the display.

Note: if the temperature display stops flashing before you have set the required temperature, you can:

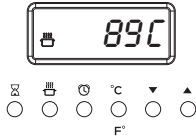
- 2b Press the $^{\circ}\text{F}$ button
 - The display will flash
- 2c Use the ▼ and ▲ buttons to increase or decrease the set temperature.



3 When the oven is preheating and during cooking

- The  indicator will show in the display.
- The  indicator will go out when the oven has reached the set temperature. Note: this indicator may turn on and off during cooking as the oven maintains the set temperature.



- The temperature indicator light will also come on when the oven is heating and will turn on and off as the oven maintains its set temperature.
- The temperature indicator light goes out when the oven has reached the set temperature.

4a To check the set temperature

- Press the  button. The display will flash showing the set temperature.
- After a few seconds the display will return to the actual oven temperature and the display will be steadily lit.

4b To check the time of day

- Press the  button. After a few seconds the display will show the oven temperature again.

5 When you have finished cooking

- Turn the function dial to O (off) to turn the oven off.

22 Cooking functions



OVEN LAMP

Only the oven light comes on. It remains on in all the cooking functions.



BAKE

The upper and lower heating elements come on. BAKE is the traditional method of cooking. It is best to cook on only one shelf at a time in this function. Ideal for large cakes and dishes that bake for several hours.



ROTISSERIE

A delicious way to cook meat and poultry. The slowly rotating meat is basted continuously in its own juices, making it tender on the inside and well browned and full of flavour on the outside. See 'Using the rotisserie'.



GRILL

Grill is the most suitable function for 'finishing off' many meals, for example browning the top of potato gratin and frittata. Use Grill to toast bread or to grill your favourite chicken, fish and steak. Use with the oven door closed and the temperature set to a maximum of 225°C. For best results, use the topmost shelf position when you want quick browning (eg toast).



DEFROST

this is not a cooking function

Only the oven fan comes on. The fan circulates air around the oven, speeding up the defrosting process by approximately 30%. Note: this function is not for cooking food.



FAN FORCED

The circular heating element and the fan come on. The oven set on FAN FORCED can cook several different foods together. Use FAN FORCED for multi-shelf cooking.



FAN GRILL

Both the grill and the fan come on. Use with the oven door closed and the temperature set to a maximum of 225°C. Ideal for roasting tender cuts of meat and poultry. Use lower shelf positions for larger items eg a whole chicken.



WARM

this is not a cooking function

Always reheat food until piping hot and then select the warm function to keep food hot.



FAN BAKE

The upper and lower heating elements and the fan come on. Ideal for dishes like lasagne that need to brown on top and also single trays of small cakes or biscuits that bake in less than an hour.

Important!

Safe food handling: leave food in the oven for as short a time as possible before and after cooking or defrosting. This is to avoid contamination by organisms which may cause food poisoning. Take particular care during warmer weather.

Using the fat filter

- Use the fat filter when roasting meat and poultry on Fan Bake, Fan Grill or Fan Forced. It helps to keep your oven clean and reduces splatter and smoking.
- Remove the fat filter before baking.
- Clean the fat filter after every use. See 'Care and cleaning'.

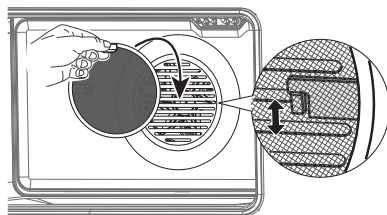

Fig. 20 Fat filter

Changing the oven from Celsius to Fahrenheit

You can set your oven to display the temperature in Fahrenheit or Celsius.

- 1 Select a cooking function.
 - 2 While the display is flashing, press ▼ to reduce the oven to the minimum temperature (50 °C / 120 °F)
 - 3 When the display stops flashing, press and hold the °C/F button until C or F flashes in the display
 - 4 Press the °C/F button to change between Celsius (C) and Fahrenheit (F).
- After a few moments the oven will turn off and the display will show the time of day.
 - Turn the function dial back to O (Off).

Cooking Guide

The settings in the following chart are guidelines only. Follow the instructions in your recipe or on packaging and be prepared to adjust the oven settings and baking times to achieve the best possible results for you.

- Shelf positions are counted from the oven floor up (1 is the lowest, 5 is the highest).
- Arrange oven shelves before you turn the oven on, then preheat the oven to the desired temperature.
- Single shelf positions below use the flat oven shelf; where a multi-shelf arrangement is recommended, the lower position uses the step-down shelf.
- Due to the width of the oven, a single shelf can usually accommodate double the standard recipe.
- Always preheat the oven before baking.
- For models with a fat filter:
 - Always use the fat filter when roasting meat or poultry.
 - Always remove the fat filter before baking.
- Do not place anything, including water or ice, on the oven floor
- Keep the door completely shut when grilling foods.
- Do not open the door during the first 3/4 of baking time.

SAVOURY

<i>Food</i>	<i>Shelves</i>	<i>Recommended Function</i>	<i>Shelf positions</i>	<i>Temp (°C)</i>	<i>Time (mins)</i>
Roast Chicken	Rotisserie	Rotisserie	1	180-210	15-20 min/450g
Lasagne	Single	Fan Bake	3	175-180	45-50
Quiche	Single	Bake	1	180-200	30-40
Pizza	Single	Bake	3	225-250	10-15
Casserole	Single	Fan Forced	3	170-190	55-70
Roast Lamb (bone in)	Single	Fan Grill (medium)	3	160-170	18-28 min/450 g
Baked Potatoes	Single	Bake	4	175-190	40-50
Beef Steak	Single	Grill	4	Hi	6-8 min / side
Beef Burgers	Single	Grill	4	Hi	12-15 min / side

BAKING

<i>Food</i>	<i>Shelves</i>	<i>Recommended Function</i>	<i>Shelf positions</i>	<i>Temp (°C)</i>	<i>Time (mins)</i>
Small cakes	single shelf	Bake	2	180-190	20-30
	multi shelf	Fan Forced	1 and 3	160-170	30-40
Scones	single shelf	Bake	2	210-230	15-20
	multi shelf	Fan Forced	1 and 3	210-230	15-20
Sponge	two small pans (20 cm), on single shelf	Bake	2	170-180	30-45
	one large pan (26 cm)	Bake	2	175	30-40
Light fruit cake	two pans (21 cm) on single shelf	Bake	2	155-165	90
Rich fruit cake	Single	Bake	2	130-150	3-6 hrs
Apple pie	Single	Bake	1	185	35-45
Quiche	Single	Bake	1	180-200	30-40
Meringues	Single	Bake	1	100-120	60
Bread rolls	Single	Bake	1	210-230	15-20
Muffins	2 x 12 muffin trays on single shelf	Fan Forced or Fan Bake	3	190-200	10-15
Pastry case (baked 'blind')	one 21 cm flan tin	Bake	1	200	10 with beans, then 10 without

Important!

- If fitted, remove the sliding shelf supports from shelf position 1 before using the rotisserie.
- Remove all oven shelves and trays.

1 Prepare the rotisserie supports.

- Place the grill tray on the benchtop.
- Insert the supports into the lock studs.
- Push the supports all the way down to lock them in firmly.

2 Secure the meat.**Important!**

Take care, the forks are sharp!

When securing the meat, ensure that:

- the skewer goes through the centre of the meat
- the forks hold the meat firmly in place
- the fork screws are tightened
- there are no loose or projecting parts. Poultry should be trussed.

Note: the rotisserie can rotate up to 6 kg of meat and is long enough to cook two chickens at the same time.

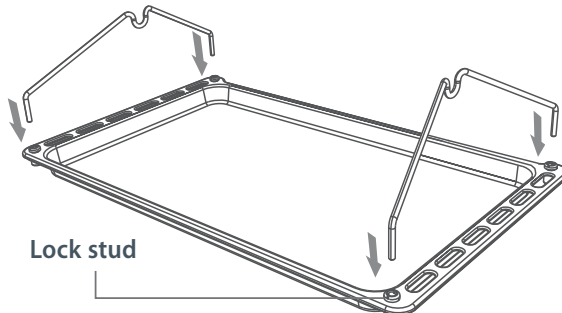

Fig. 21a Prepare the rotisserie supports

Rotate the fork screws to loosen and tighten

Fig. 21b Secure the meat

- 3 Position the skewer on the supports.
 - Place the skewer on the supports, and check that the meat does not touch the grill tray.
 - Twist the handle off. It must not be left in the oven.
- 4 Place the rotisserie in the oven (check that the fat filter is in place first).
 - Slide the grill tray all the way to the back on shelf position 1.
 - Move the rotisserie drive hole cover aside (right-hand wall of the oven). Insert the skewer fully into the rotisserie drive hole. Ensure the left hand side of the skewer is properly located on the supports.
- 5 Start the rotisserie
 - Select the Rotisserie function.
 - Set the temperature.
 - The rotisserie will start to rotate.

Important!

- *Always turn the function dial to O (off) before removing the rotisserie.*
- *Always ensure that poultry is cooked thoroughly.*
- *During use, the rotisserie components become hot. If you leave the oven door open after using the rotisserie, parts of the control panel may also become hot. Use oven mitts and take extra care, especially when removing the rotisserie support rack from the hot oven.*
- *Always clean the fat filter after every use. See 'Care and cleaning'.*

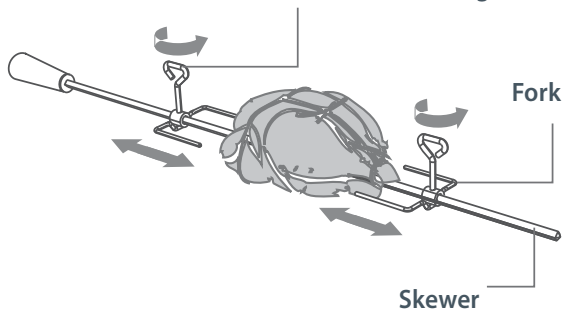
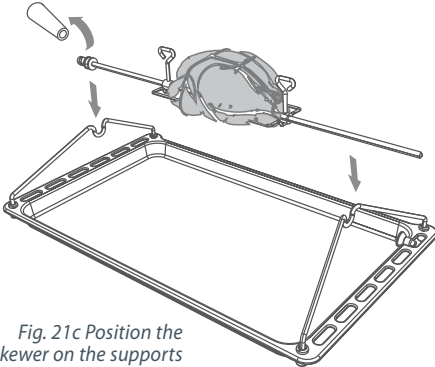

Fig. 21c Position the skewer on the supports

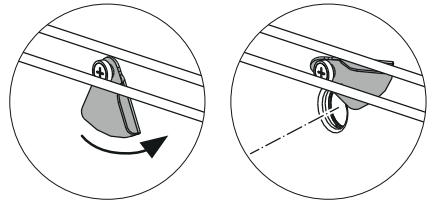

Fig. 21d Rotisserie drive hole cover

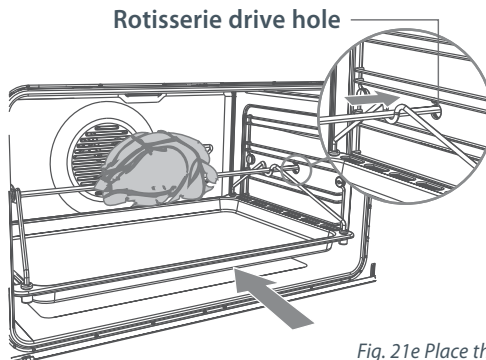

Fig. 21e Place the rotisserie in the oven

28 Using the electronic timer

You can use the timer at any time, even when the oven is not in use.

Important!

The timer does NOT turn the oven off.

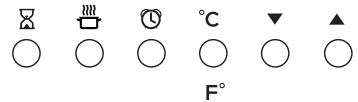

To set the timer

- 1 Press the timer ⌚ button.
 - The time will show 0:00
- 2 Press ▼ and ▲ buttons to set the time you want (up to 3 hours in one minute steps)
 - The timer 🔔 indicator will come on.
 - After a few seconds the time will start counting down, the display will show the time of day (if the oven is off) or temperature (if the oven is on) and will be steadily lit.

To check the remaining time

- 3 Press the timer ⌚ button.
 - The timer counts down in minutes (hr:min) until the last minute when it counts down in seconds.

To cancel the timer

- 4 Press the timer ⌚ button.
 - The remaining time will be displayed. Press the ▼ button to scroll the time down to 0:00
 - After a few seconds the clock will show the time of day (if the oven is off) or temperature (if the oven is on).

When the time is up

- The timer will beep and the timer 🔔 indicator go out.
- Press any button to stop the beeping.

To set the oven for automatic cooking



1 Set the oven

- Check the clock shows the correct time (eg 12:07).
- Select the function and set the temperature.
The oven will turn on.

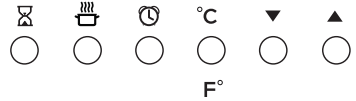

2 Set the cooking time

- Decide how long the food will take to cook, allowing time for preheating if necessary (eg 40 minutes).
- Press .
- Use ▼ and ▲ to set the cooking time. **A** will show in the display.

3 Set the stop time

- Decide when you want your food to be ready by (eg 13:30).
- Press .
- Use ▼ and ▲ to set the stop time.

You can turn the oven on manually and set it to turn off automatically by setting the stop time (step 3 above).

When automatic cooking is set

- If there is time before cooking starts, the oven will turn off and the pre-set temperature and **A** will show in the clock display, indicating the oven is set for automatic cooking. Note: the cooling fan may stay on.
- The oven will automatically turn on at the required time (eg 12:50) and turn off at the set stop time (eg 13:30).
- To see the remaining cooking time, press .
- To see the set stop time, press .

To cancel automatic cooking

- 1 Press and hold ▼ and ▲ together for 3 seconds
- 2 Turn the function dial to O (Off).

When the stop time is reached

- The oven will turn off, the timer will beep.
 - The display will show *End* and the **A** will flash.
- 1 Press any button to stop the beeping
 - 2 Turn the function dial to O (Off).

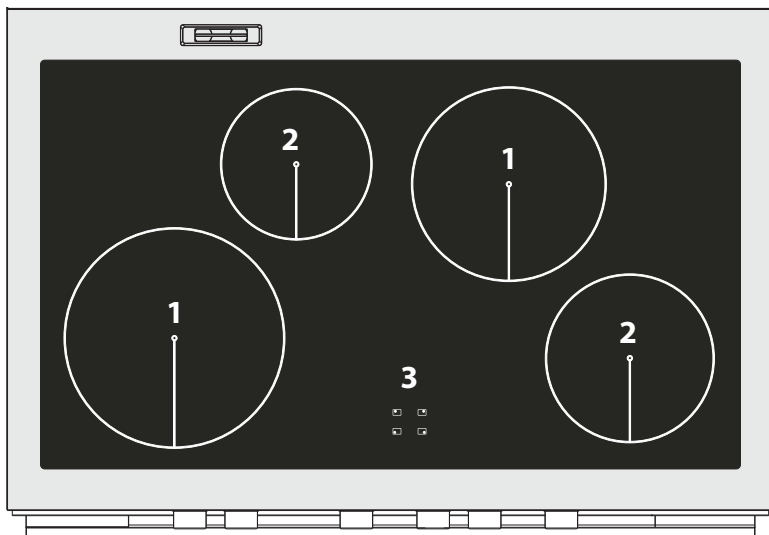

Fig 22 Cooktop layout

- 1 2300 W (3000 W *) zone
- 2 1400 W zone
- 3 Cooking zones display

* Maximum power output when set for PowerBoost (see section 'Using your cooktop's special features')

Important!

Disconnect the appliance from the mains if the ceramic glass is cracked and contact Customer Care. Metallic objects such as knives, forks, spoons and lids should not be placed on the cooktop surface since they can get hot.









Cooking zones display

The ceramic cooktop is fitted with induction cooking zones. These circular zones are controlled by separate dials positioned on the control panel below.



Fig 23 Cooking zones display



At the front, is the display for the cooking zones (one for each zone). Each zone display is activated by its corresponding control dial and displays:

	= Cooking zone Off (not activated)
	= Cooking zone On (activated but not operating). If all the zones are in zero setting, the display switches off automatically (cooking zones Off) after about 10 seconds.
 - 	= Power levels
	= Auto Heat-reduce feature
	= PowerBoost feature
	= Hot Surface indicator
	= Pan detection indicator
	= Childlock

Note: each lit figure refers to the relevant cooking zone

Choosing the right cookware

Important!

- Only use cookware with a base suitable for induction cooking. Look for the induction symbol on the packaging or the bottom of the pan.
- You can check whether your cookware is suitable by carrying out a magnet test. Move a magnet towards the base of the pan. If it is attracted, the pan is suitable for induction.
- If you do not have a magnet:
 - 1 Put some water in the pan you want to check.
 - 2 Place a suitable pan on the cooking zone you wish to use. Make sure the bottom of the pan and the surface of the cooking zone are clean and dry. Turn on the cooking zone.
 - 3 If  does not flash in the display and the water is heating, the pan is suitable. Note: If the pan detection symbol  does appear on the display, your pan is not suitable and the cooktop will not operate. After 10 minutes without detecting any pan, the cooking zone switches off automatically and can only be switched on after the control dial has been returned to "0" (Off).
- Cookware made from the following materials is not suitable: pure stainless steel, aluminium or copper without a magnetic base, glass, wood, porcelain, ceramic, earthenware.

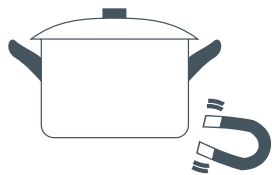

Do not use cookware with jagged edges or a curved base.

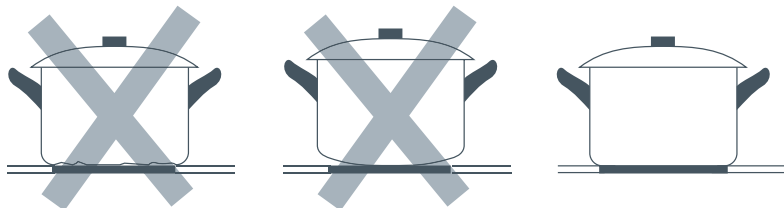

Make sure that the base of your pan is smooth, sits flat against the glass, and is approximately the same size as the cooking zone. Always centre your pan on the cooking zone.

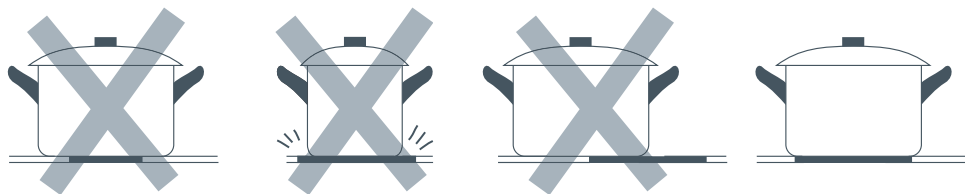

Always lift pans off the cooktop– do not slide, or they may scratch the glass.

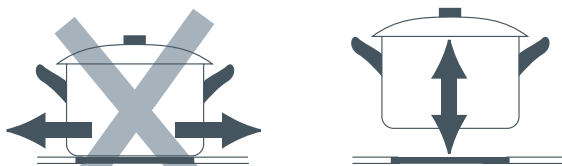

Important!

the cooking zones will not operate if the pan diameter is too small ( will appear on the cooking zone display). To correctly use the cooking zones follow the indications given in the following table.

Induction cooking zone	Minimum pan diameter recommended	Maximum pan diameter recommended
Front right	110 mm	240 mm
Rear right	145 mm	300 mm
Rear left	110 mm	240 mm
Front left	145 mm	300 mm

Note: some types of pans can cause noise when used on an induction cooking zone. This noise does not mean any failure on the appliance and does not influence the cooking operation.

Control dials

Each cooking zone is activated by a separate control dial positioned on the control panel. The functions are arranged on the actual dial itself.

If a cooking zone is not turned off ('0' position) the electronic system automatically switches it off after a pre-set time ranging from 90 minutes to 6 hours, depending on the power setting.

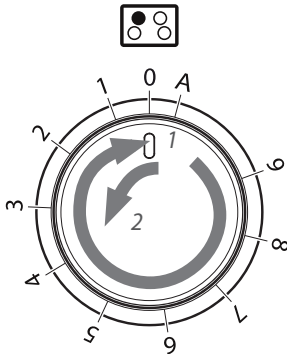

Fig 24 Control dial - rear left & front right zone

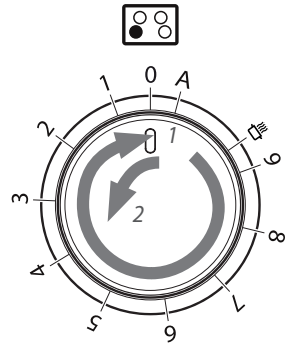



Fig 25 Control dial - front left & rear right zone

Power level

Turn the dial clockwise to set the desired power level between **1** (minimum) and **9** (maximum). The power level can be modified at any time by turning the dial clockwise or anti-clockwise to a different setting.

The cooking zone display shows the selected level.

Hot Surface Indicator

When the temperature of a cooking zone is still hot, the relevant Hot Surface indicator  lights up on the display to alert you of the hot surface. Avoid touching the cooktop surface over the cooking area. Please pay special attention to children. When the  is lit on the display, it is still possible to start cooking again; just turn the control dial to the required power level. The indicator will disappear when the surface has cooled down to a safe temperature.

Childlock



When not using the induction cooktop, set the Childlock to prevent children from accidentally switching on the cooking zones.

Ensure all cooking zones are switched Off ('0' position), then turn the control dials of the left cooking zones simultaneously to the left ('A' setting) and hold the dials in this position until  lights up on the cooking zones display; then release the dials.

To deactivate the childlock repeat the same procedure until the  goes out; then release the dials.

Using the Auto Heat-reduce feature

This feature is available on all the cooking zones

Turn the control dial anti-clockwise to the 'A' setting and then release the dial (after the 'beep'); the  symbol lights up on the corresponding cooking zone display. Within 5 seconds turn the dial to the desired power level (between 1 and 9); once a setting has been selected,  and the chosen power level will flash in alternation on the control panel display.

This feature allows the cooking zone to operate at the maximum power (100%) for a time proportional to the selected power level; after this time the cooking zone will operate at the selected level.



While this feature is operating it is possible, at any time, to increase the selected power level but it is not possible to decrease the power.

The Auto Heat-reduce feature can be disabled by turning the dial anti-clockwise to a lower power level, turning the dial to the '0' (Off) position or by selecting the PowerBoost feature.

Note: If removing the pan from the cooking zone before the programme has been completed, the Auto Heat-reduce feature will be completed with the remaining time if the pan is put back on the cooking zone within 10 minutes.

Using the PowerBoost feature

This feature is available on the front left/rear right zones only.

Turn the control dial clockwise to set the maximum power level (9), then turn clockwise again to the  setting and release the dial (after the 'beep'); the control dial returns to the maximum setting (9) automatically and the  symbol lights up on the corresponding cooking zone display. The PowerBoost feature is now on.

This feature allows the cooking zone to operate at the PowerBoost maximum power (above the rated power) for a maximum of 5 minutes; it could be used, for example, to rapidly heat up a large amount of water. After 5 minutes the P will flash for a few seconds and then the power level will automatically drop to level 9.

The PowerBoost feature can be disabled by turning the dial anti-clockwise to a lower power level, turning the dial to the '0' (Off) position or by turning the dial again to the  setting; in this case the cooking zone operates at the power level 9.

Note: if a cooking zone is still hot, it is not possible to use the PowerBoost feature and  will flash if you try to activate it. The cooking zone is automatically set to the maximum power level (9).

The PowerBoost feature is always limited to a maximum of 10 minutes. You can activate the PowerBoost feature again after 5 minutes.

Important!

The PowerBoost feature is not suitable for use with non water based cooking.

Do not use this function for heating oil (e.g. deep fat frying). The power density may be too high and it could damage the cookware.

Maximum usable power for the cooking zones

The right and left cooking zones are controlled by two separate power boards and the maximum total power per each power board is 3700 W.

Should the cooking zones of one power board require more than 3700 W, the last selected power level has priority and the power of the other cooking zone is automatically reduced to the remaining power available.

If this occurs, the cooking zone will display a flashing figure for about 3 seconds before automatically displaying the new power level.

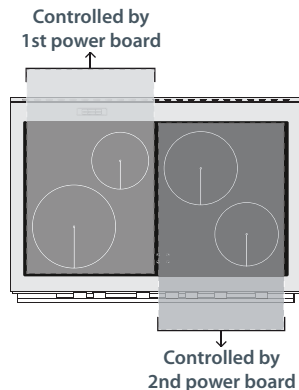

This means for example that:

- When setting PowerBoost for the second zone, the setting for the other zone could be reduced to the remaining power available.
- When setting PowerBoost for a zone and then another setting on the second zone, if the total power exceed 3700 W the PowerBoost feature is automatically turned off and the power reduced to the maximum power available.

Thermal protection

The induction cooktop is fitted with safety devices to protect the electronic system and to protect each cooking zone from overheating.

In case of overheating, one of the following automatic functions could be started by the electronic system:

- PowerBoost feature automatically turned off and power reduced;
- one or more cooking zone switched off;
- cooling fan motor of the induction unit switched on.

Heat settings

The settings below are guidelines only. The exact setting will depend on several factors, including your cookware and the amount you are cooking. Experiment with the cooktop to find the settings that best suit you. In general, the lower heat settings offer a more gradual control, whereas the higher heat settings have a more pronounced step change in power.

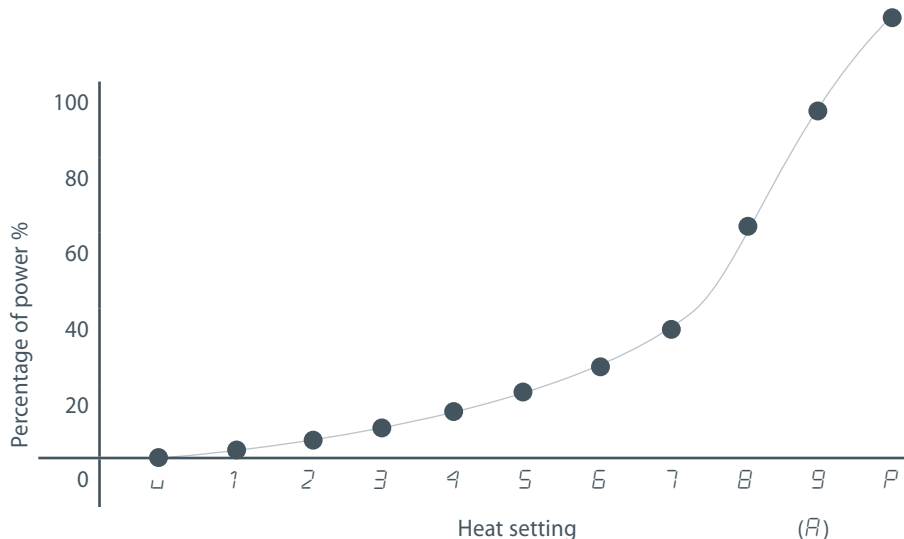

Heat setting	Suitability
1 - 2	<ul style="list-style-type: none"> ■ delicate warming for small amounts of food ■ melting chocolate, butter, and foods that burn quickly
3 - 4	<ul style="list-style-type: none"> ■ gentle simmering ■ cooking rice
5 - 6	<ul style="list-style-type: none"> ■ rapid simmering ■ pancakes
7 - 8	<ul style="list-style-type: none"> ■ sautéing ■ cooking pasta
9	<ul style="list-style-type: none"> ■ stir-frying ■ searing
P	<ul style="list-style-type: none"> ■ boiling water

Note: the settings and suitability shown are subject to variability due to differences in cookware construction.

Important!

Before you start cleaning your cooker, please:

- *Read these cleaning instructions and the 'Safety and warnings' section at the start of this user guide.*
- *Turn the cooker off at the wall.*
- *Make sure the cooker is a safe temperature to touch.*
- *Do not use a steam cleaner.*
- *Do not keep flammable substances in the oven.*

General advice

- Wipe down the cooktop and wipe out the oven after every use.
- Wipe up spills. Avoid leaving alkaline or acidic substances (such as lemon juice or vinegar) on the surfaces.
- Do not use cleaning products with a chlorine or acidic base (ie citrus-based cleaners).

Cleaning the outside of the cooker

Important!

- *Do not use abrasive cleaners, cloths or pads on the outside surfaces.*
- *Immediately wipe off any caustic cleaners if they are spilled onto the oven door handle.*

Wipe the outside surfaces often, using warm water and a mild household detergent. The stainless steel may also be cleaned with a suitable cleaner and polish.

Note: if you choose to use a commercial stainless steel cleaner, please read the label to make sure it does not contain chlorine compounds as these are corrosive and may damage the appearance of your cooker.

Caring for your cooktop

Important!

- *Some heavy-duty and nylon scourers can scratch the ceramic glass of your cooktop. Always read the label to check if your scourer is suitable for cleaning ceramic glass cooktops.*
- *Use ceramic glass cleaner on the cooktop while it is warm to touch. Rinse and wipe dry with a clean cloth or paper towel. The cooktop may become stained if cleaning residue remains.*
- *Remove any food, spillovers or grease from the cooktop while it is still warm using a razor blade scraper suitable for ceramic glass surfaces. Do not use knives or any other sharp object for cleaning. Take extra care to avoid damaging the seal at the edges of the ceramic glass surface.*
- *Do not use cleaning products with a chlorine or acidic base.*

Metallic stains

Copper-based or aluminium cookware may cause metallic staining. These stains show as a metallic sheen on the cooktop. If the cooktop is not cleaned after every use and the stains are allowed to burn onto the surface, they may react with the glass and will no longer be removable. To help prevent such damage, clean the cooktop after every use and apply a glass cooktop conditioner.

Cleaning melts and spillovers

Anything that melts onto the ceramic glass surface or food spills with a high sugar content may cause pitting of the ceramic glass surface if they are left there to cool. Examples include:

- plastic wrap
 - melted aluminum foil
 - sugar, sugary syrups, jams and jellies
 - vegetables and vegetable water with a high sugar content eg peas, sweet corn, beetroot.
- Remove these spills immediately with a special razor blade cooktop scraper, taking care not to scratch the glass. Follow the steps below:
- 1 Turn the element off and carefully scrape the spill to a cool area of the cooktop surface.
 - 2 Clean the spill up with a cloth or paper towel.
 - 3 As soon as the cooktop is cool enough to safely touch, clean with cooktop cleaner.

Cleaning the stainless steel surround strip

- To remove fingerprints and other marks, wipe with a clean damp cloth and dry with a lintfree cloth.

Cleaning the inside of your oven

- Do not use oven cleaner on catalytic panels. Remove the catalytic panels if additional oven cavity cleaning is required. See 'Fitting and removing catalytic panels'
- Do not use abrasive cleaners, cloths or pads to clean the enamel.
- To make cleaning easier, you can remove the side racks, the oven door, and the fat filter.

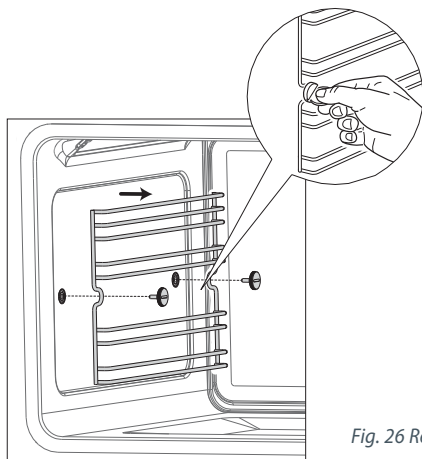

Fig. 26 Removing the side racks

Drop-down grill element

- To lower the grill element: use a flat-head screwdriver or a small coin to loosen the element fixing screws.
- When you have finished cleaning the oven ceiling, raise the grill element and screw the element fixing screws back onto the studs. Make sure that the fixing screws are tightened and the element is held securely in place. The grill element itself is self-cleaning.

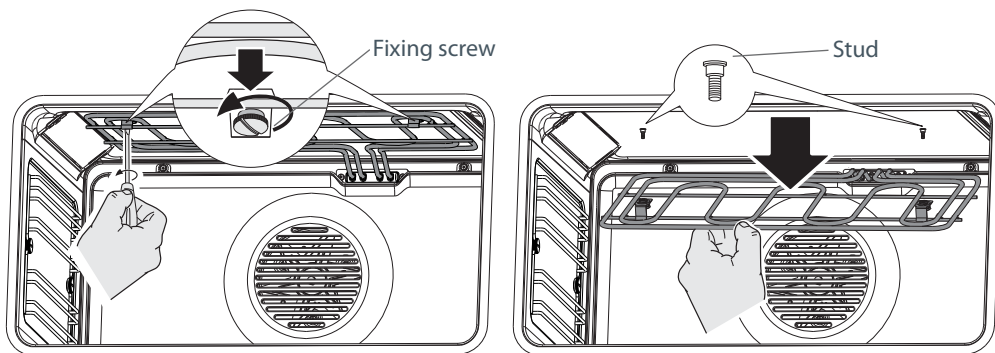

Fig.27 Drop-down grill element

Cleaning the enamel cavity

Clean the enamel on the inside of the oven when it has cooled down, using household detergents. You may use 'off the shelf' oven cleaners, if you carefully follow the manufacturers' instructions.

Important!

Do not use oven cleaner on catalytic panels.

Cleaning the fat filter

Clean the fat filter after every use. If the filter is not cleaned, it will block and shorten the life of the fan element. If the filter is lightly soiled, place it in a dishwasher on normal wash. If the filter is very dirty, place in a saucepan with either two tablespoons of clothes washing powder, or one tablespoon of dishwashing powder. Bring to the boil and leave to soak for at least 30 minutes. Rinse the filter in clean water and dry.

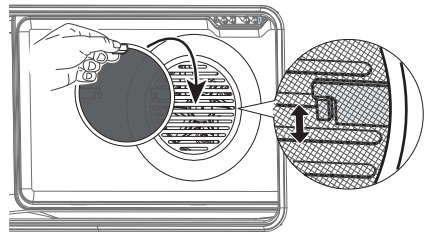

Fig. 28 Fat filter

Cleaning the grill tray and shelves

Clean these in hot, soapy water.

After cleaning slide in the shelves, making sure that:

- they are between the two wires of a shelf position;
- the stop notches point down;
- the guard rail is at the back.
- Note: the grill tray should be positioned between the two wires of a shelf position and orientated as shown.

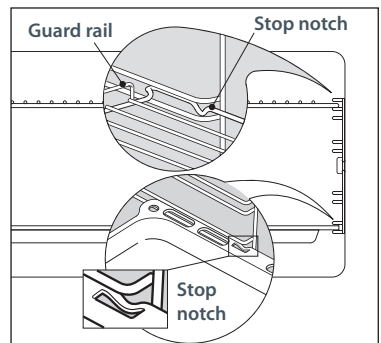

Fig. 29 Oven shelves and grill tray

Fitting and removing the sliding shelf supports

When fitting the sliding shelf supports, make sure that you fit:

- the catalytic panels first. See 'Fitting the catalytic panels'.
- the side racks
- the slides to the top wire of a shelf position
- both sides of each pair of slides
- both slides on the same level.

Important!

Remove the side racks first to make removing the sliding shelf supports easier.

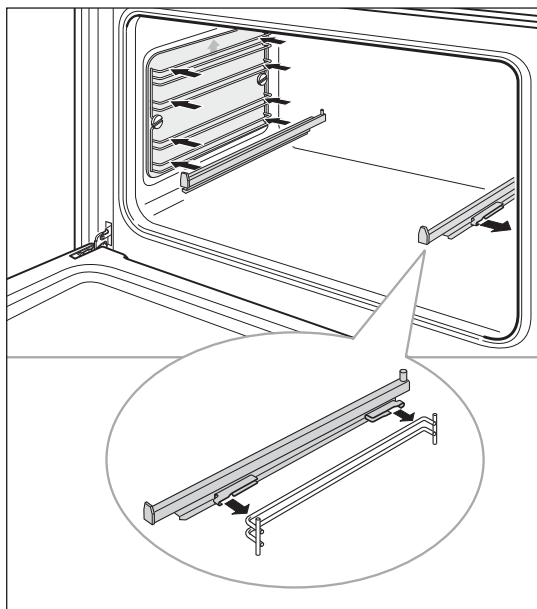

Fig. 30a Fitting the sliding shelf supports

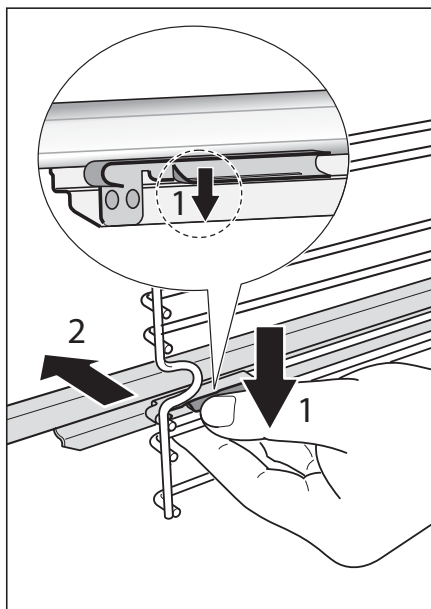

Fig. 30b Removing the sliding shelf supports

Storage Drawer

- The drawer opens like a normal drawer. The drawer slides stop if from sliding all the way out.

To remove the drawer

- 1 Open the drawer fully
- 2 Press the lever on the left guide rail down and the right guide rail up
- 3 Holding the levers, disengage and remove the drawer. Do not use excessive force or you may damage the drawer slides

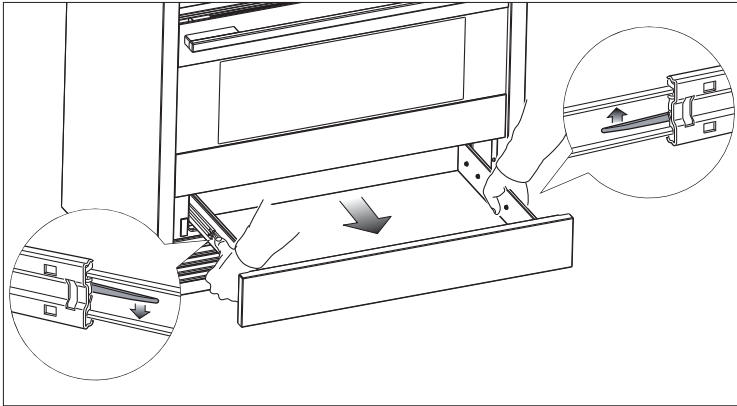

Fig. 31 Removing the drawer

Replace the drawer

- 1 Insert the drawer rails into the guide rails
- 2 Gently push the drawer in completely, the catches will automatically hook.

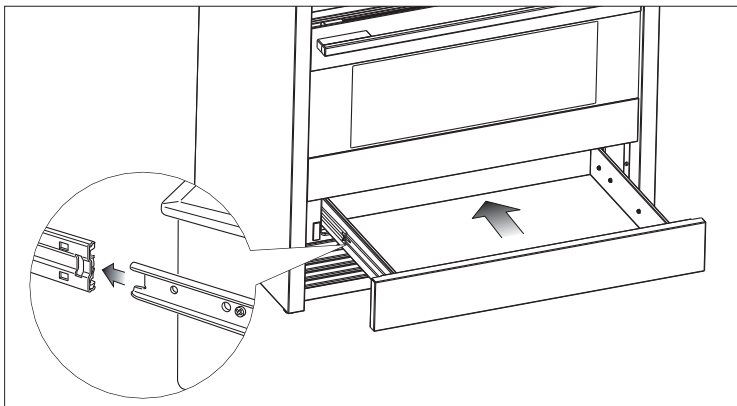
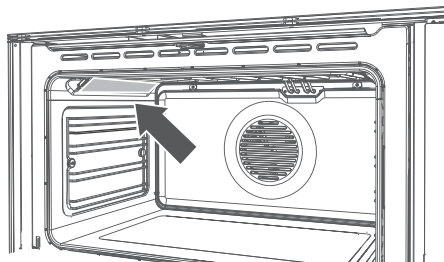
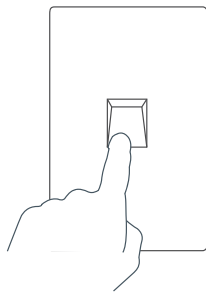

Fig. 31 Replacing the drawer

Replacing the oven light bulbs

The oven light bulbs (12V/20 W halogen) have a very long life, but if you should need to replace one, use only a replacement bulb purchased from your nearest Fisher & Paykel dealer and follow these steps. **Note: oven bulb replacement is not covered by your warranty.**



- 1 Allow the oven to cool down, then turn it off at the mains power supply (wall switch).

- 2 Remove any oven shelves that may get in the way.

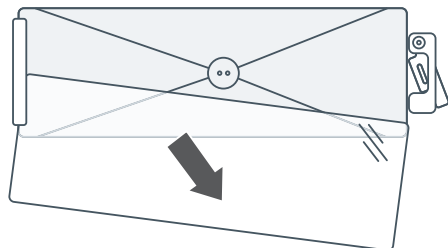
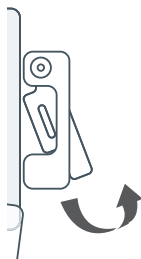

- 3 Using a flat-head screwdriver, twist and lift the retainer clip upwards to release the glass cover. Hold the glass cover to prevent it falling.

- 4 Carefully lift the glass cover out of the retaining bracket in the back and pull out the faulty bulb.

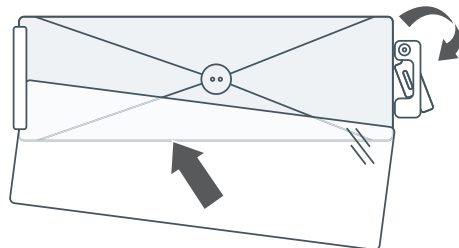

- 5 Hold the replacement bulb in a soft cloth or tissue (touching the bulb will reduce its life span) and insert it into the socket.

- 6a Reposition the glass cover and twist the retainer clip back in place.
- 6b Turn the oven back on at the mains power supply (wall switch).

Removing and replacing the door glass panes for cleaning.

Make sure you follow the precautions and instructions below very carefully. Replacing the glass panes and the door incorrectly may result in damage to the oven and may void your warranty.

Your oven door has 3 panes of glass. The inner and middle panes may be removed for cleaning.

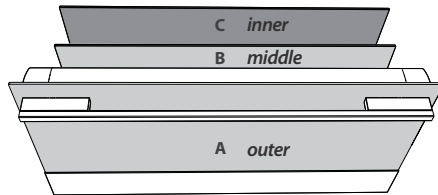

Important!

- *Switch the oven off at the wall before removing the door.*
- *Take care, the oven door is heavy. If you have any doubts, do not attempt to remove the door.*
- *Make sure the oven and all its parts have cooled down. Do not attempt to handle the parts of a hot oven.*
- *Take extreme care when handling the glass panes. Avoid the edges of the glass bumping against any surface. This may result in the glass shattering.*
- *Don't use oven cleaners or any other harsh/abrasive cleaners, cloths, scouring pads, steel wool or sharp metal scrapers to clean the glass surfaces. These scratch the glass and may damage its special coating, which in turn could result in the glass cracking or shattering.*
- *If you notice any sign of damage on any of the glass panes (such as chipping or cracks), do not use the oven. Call your Authorised Repairer or Customer Care.*
- *Make sure you replace all the glass panes correctly. Do not use the oven without all glass panes correctly in place.*
- *If the glass panes feel difficult to remove or replace, do not force them. Call your Authorised Repairer or Customer Care for help. Note: service visits providing assistance with using or maintaining the oven are not covered by your warranty.*

Removing the door

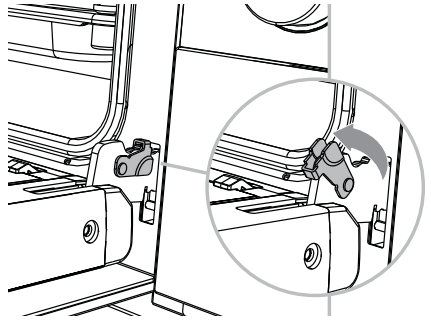
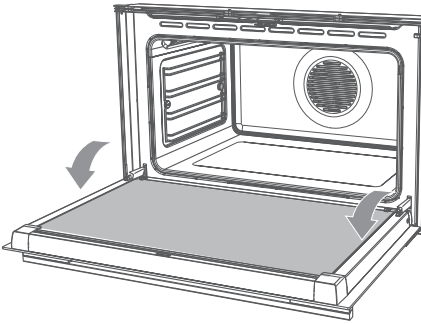

- 1a Turn the oven off at the wall. Make sure you have prepared enough space for resting the door and its glass panes on a clean, flat surface.
- 1b Open the door to its full extent.

- 2 Open the levers on the left and right hinges to their full extent, as shown.

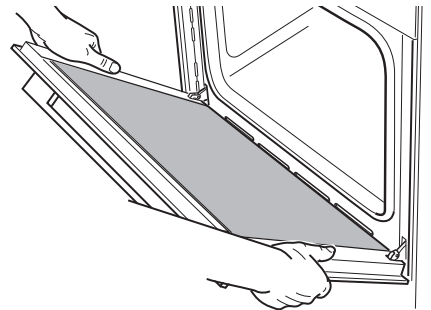
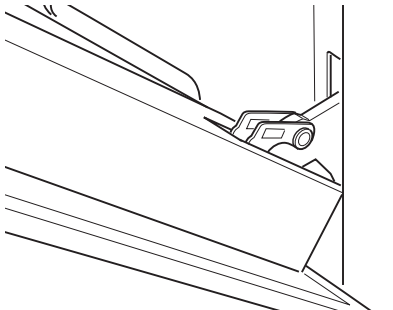

- 3 Gently close the door until the left and right hinge levers are hooked to the door.

- 4 Hold the door firmly, as shown.

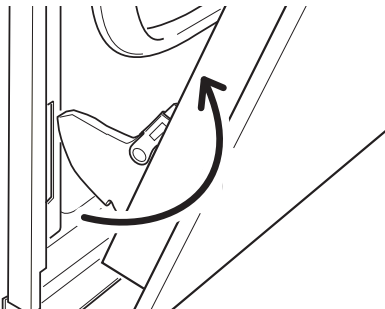

- 5a Lift the door and disengage the hinges.
- 5b Rest the door on a soft surface. Ensure you lay it with the handle side down.

Remove the inner and middle glass pane

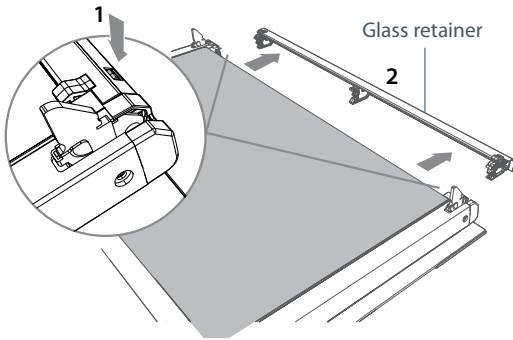

- 1 Press down on both tabs (1) to release the glass retainer (2).

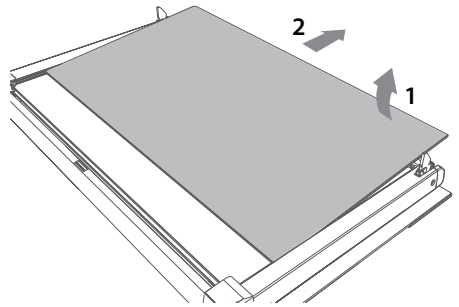

- 2 Lift the inner pane (C) slightly (1), then gently slide out (2).

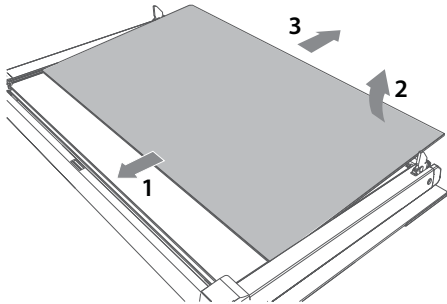

- 3 Slide the middle pane (B) slightly towards yourself (1), then lift (2) and slide out (3).

After cleaning, replace the glass panes

When replacing the glass panes, make sure that:

- you replace all panes correctly, as shown. Each pane must be in the position described below in order to fit into the door and to ensure that the oven operates safely and correctly
- you take extra care not to bump the edges of the glass against any object or surface
- you do not force any of the panes into place. If you are experiencing difficulties replacing the panes, remove them and start the process again from the beginning. If this still does not help, call Customer Care.

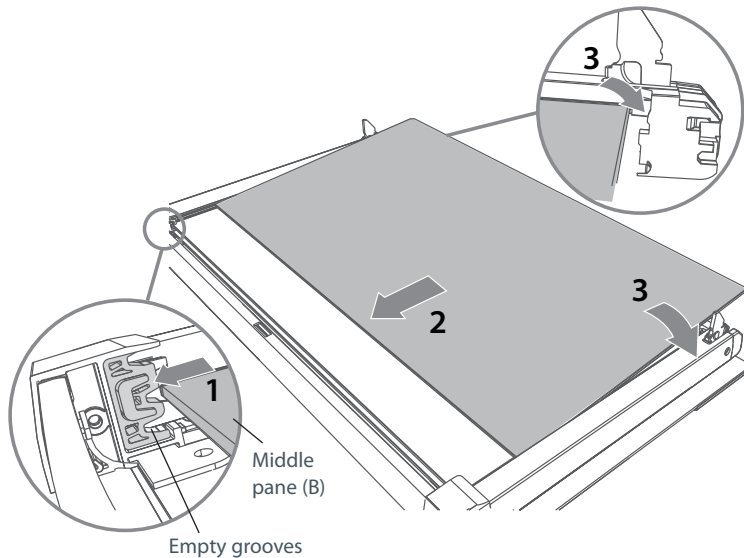

- 1 Take the middle pane (B) and hold it firmly.

Important!

Check you are holding the pane the correct way. You should be able to read the wording on it as it faces you.

- 2 Insert the pane into the middle pair of grooves (1), push it slightly towards yourself (2) and gently lower into place (3).

Important!

Use the middle pair of grooves. The pair of grooves closest to the outer pane must remain empty.

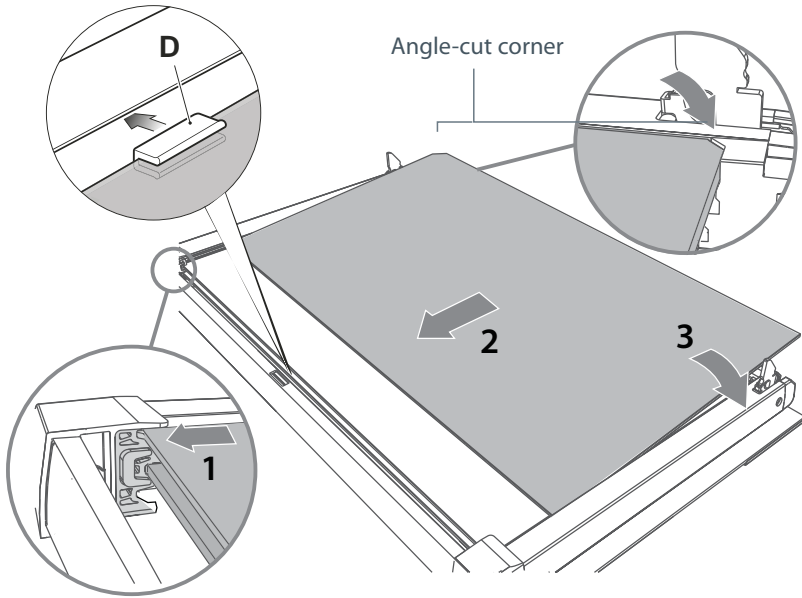

- 3 Take the inner pane (C), holding it with the angle-cut corner orientated as shown. Insert it in the uppermost pair of grooves (1), push it slightly towards yourself (2) and gently lower into place (3).

Important!

Make sure that the angle-cut corner of the inner pane (C) is at the bottom of the oven door, on the left-hand side. It has to be in this position for the door to function correctly.

Check that the gasket (D) is in place. It should sit on the inner pane of glass in the centre as shown.

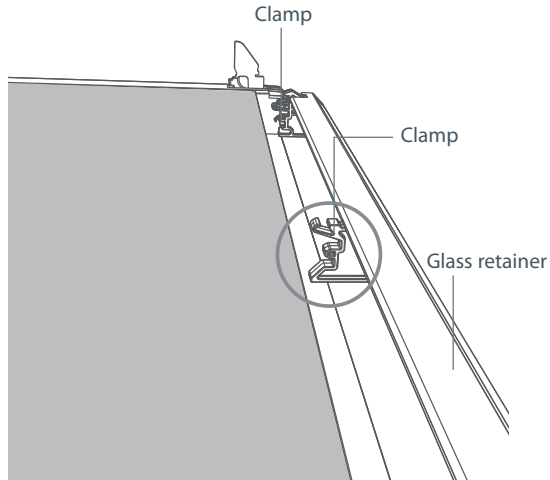

- 4 Position the glass retainer, as shown. It should sit on the bottom edge of the outer glass (A). Check that the clamps of the glass retainer are not deformed or damaged.

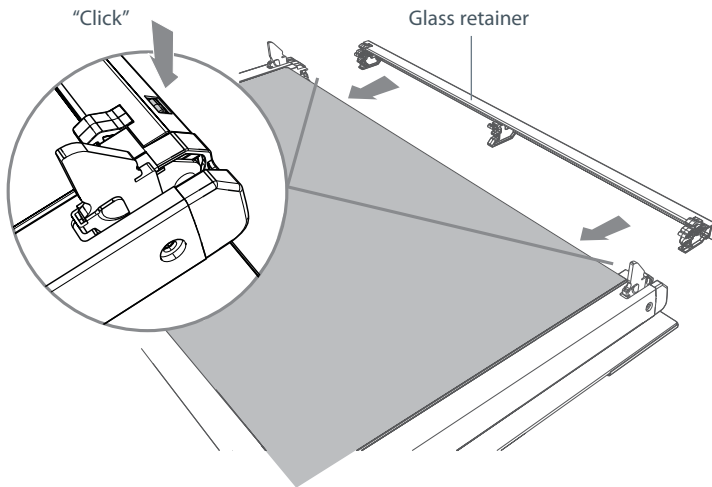

- 5 Gently push the glass retainer back into place. You should be able to hear the tabs on both sides click as they lock the glass retainer in.

Important!

Make sure the glass retainer is correctly and firmly in place and that the glass panes are secure.

Refit the door

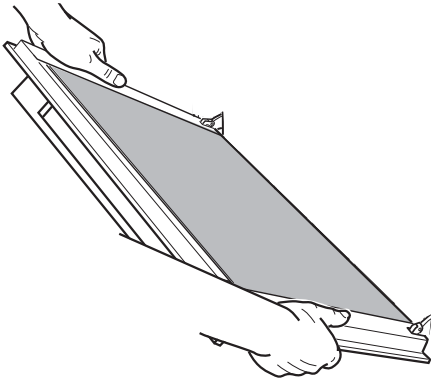

1 Hold the door firmly.

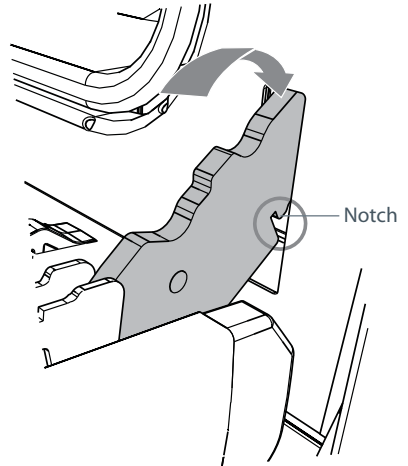

2 Insert the hinge tongues into the slots, making sure that the notches on both sides drop into place as shown.

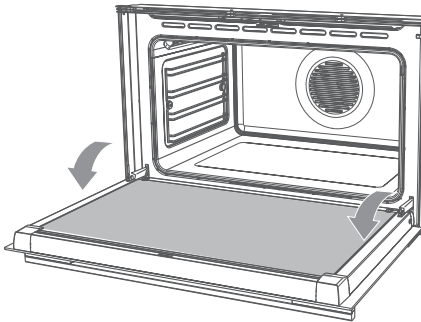

3 Open the door to its full extent.

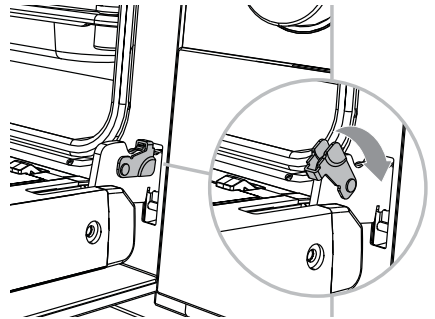

4a Fully close the levers on the left and right hinges, as shown.

4b Close the door, turn the power supply to the oven on at the wall.

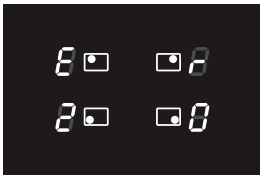
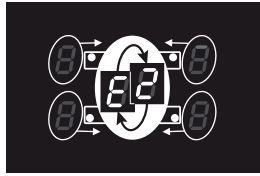
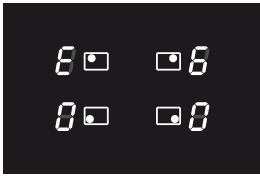
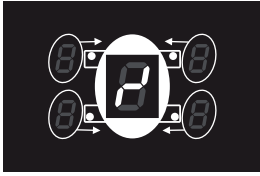

Error codes on the cooking zones display

Error code	Example	What to do
Erxx or Ex (not E2 or EH) or display not operative		<ol style="list-style-type: none"> 1 Switch off the cooker and disconnect it from the mains. 2 Wait for about 1 minute, then reconnect the cooker and turn on the cooking zones. 3 Wait for about 1 minute and if the error message does not appear again the cooking zones can be used. 4 If the error message does not disappear repeat step from 1 to 3. 5 If the problem continues do not use the induction cooktop (only use the oven) and contact your Authorised Service Centre.
E2 or EH		<p>'E' and '2' alternating for one or more cooking zones. This indicates an overheating of the cooking zone/s.</p> <ol style="list-style-type: none"> 1 Switch off the cooking zone/s and leave to cool. 2 If the problem continues do not use the induction cooktop (only use the oven) and contact your Authorised Service Centre.
E6 or display not operative		<p>The cooker has been incorrectly connected. The appliance should be connected to the appropriate power supply by a qualified technician.</p>
Symbol as per side figure		<p>This indicates an incorrect operation of one or more cooking zone control dial.</p> <ol style="list-style-type: none"> 1 Turn the cooking zone control dials to the '0' (Off) position, then switch off the cooker and disconnect it from the mains. 2 Wait for about 1 minute, then reconnect the cooker and turn on the cooking zones. 3 Wait for about 1 minute and if the error message does not appear again the cooking zones can be used. 4 If the error message does not disappear repeat step from 1 to 3. 5 If the problem continues do not use the induction cooktop (only use the oven) and contact your Authorised Service Centre.

Troubleshooting chart

Problem	Possible causes	What to do
The cooktop cannot be turned on.	No power.	Make sure the cooker is connected to the power supply and that it is switched on at the wall. Check whether there is a power outage in your home or area. If you've checked everything and the problem persists, call your Authorised Service Centre or Customer Care.
The glass is being scratched.	Rough-edged cookware.	Use cookware with flat and smooth bases. See 'Choosing the right cookware'.
	Unsuitable, abrasive scourer or cleaning products being used.	See 'Care and cleaning'.
Some pans make crackling or clicking noises.	This may be caused by the construction of your cookware (layers of different metals vibrating differently).	This is normal for induction cookware and does not indicate a fault.
The cooktop makes a low humming noise when used on a high heat setting (especially PowerBoost).	This is caused by the technology of induction cooking.	This is normal, but the noise should quieten down or disappear completely when you decrease the heat setting.
Fan noise coming from the cooktop.	A cooling fan built into your cooktop has come on to prevent the electronics from overheating. It may continue to run even after you've turned the cooktop off.	This is normal and needs no action. Do not switch the power to the cooktop off at the wall while the fan is running.

Troubleshooting chart

Problem	Possible causes	What to do
Pans do not become hot and  appears in the display.	The cooktop cannot detect the pan because it is not suitable for induction cooking.	Use cookware suitable for induction cooking. See section 'Choosing the right cookware'.
	The cooktop cannot detect the pan because it is too small for the cooking zone or not properly centred on it.	Centre the pan and make sure that its base matches the size of the cooking zone.
The fan comes on when I select the Light function  .	This is normal.	

Before you call for service or assistance ...

Check the things you can do yourself. Refer to the installation instructions and your user guide and check that:

- 1 your product is correctly installed
- 2 you are familiar with its normal operation.

If after checking these points you still need assistance, please refer to the Service & Warranty book for warranty details and your nearest Authorised Service Centre, or contact us through our website: www.fisherpaykel.com.

56 Warranty and service

This cooker has been designed and constructed in accordance with the following codes and specifications:

In New Zealand and Australia:

AS/NZS 60335-1 General Requirements for Domestic electrical appliances

AS/NZS 60335-2-6 Particular Requirements for Domestic electrical cooking appliances

AS/NZS CISPR 14.1:2010 Electromagnetic Compatibility Requirements.

Product details

Fisher & Paykel Ltd

Model Serial No.

Date of Purchase Purchaser

Dealer Suburb

Town Country

www.fisherpaykel.com

Fisher & Paykel

Copyright © Fisher & Paykel 2013. All rights reserved.

The product specifications in this booklet apply to the specific products and models described at the date of issue. Under our policy of continuous product improvement, these specifications may change at any time. You should therefore check with your Dealer to ensure this booklet correctly describes the product currently available.

Free Manuals Download Website

<http://myh66.com>

<http://usermanuals.us>

<http://www.somanuals.com>

<http://www.4manuals.cc>

<http://www.manual-lib.com>

<http://www.404manual.com>

<http://www.luxmanual.com>

<http://aubethermostatmanual.com>

Golf course search by state

<http://golfingnear.com>

Email search by domain

<http://emailbydomain.com>

Auto manuals search

<http://auto.somanuals.com>

TV manuals search

<http://tv.somanuals.com>