

# FT28D

## Features

- ◆ Dome Tweeter
- ◆ 8 ohm impedance
- ◆ 1kHz to 50kHz frequency response
- ◆ 90dB sensitivity at 1W/1m (3.3ft)
- ◆ 0.528kg (1.164 lb) net weight

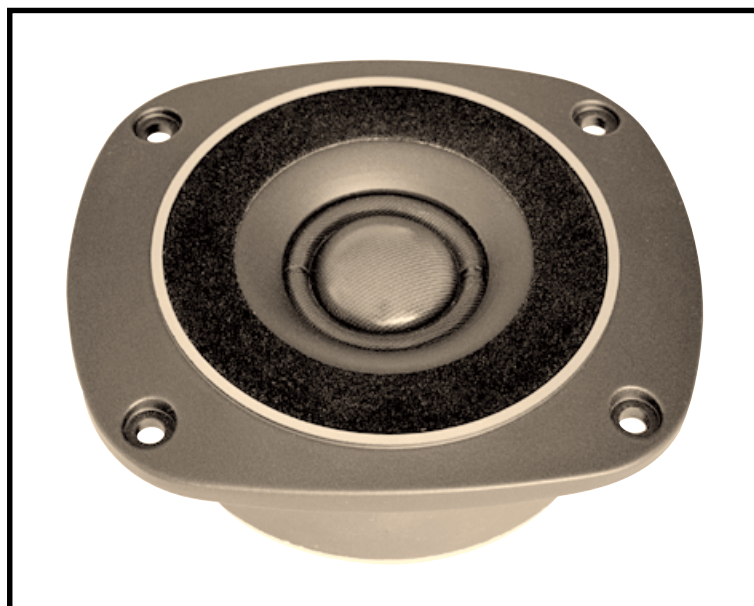

## Specifications

Impedance	: 8 ohm
Reproduction Frequency Response	: 1kHz - 50kHz
S.P.L.	: 90dB/W (m)
Music Power	: 40W
Recommended Cross-over Frequency	: more than 2kHz
Magnet Weight	: 228.3g (0.503 lb)
Net Weight	: 528g (1.164 lb)

## Frequency Response / Impedance

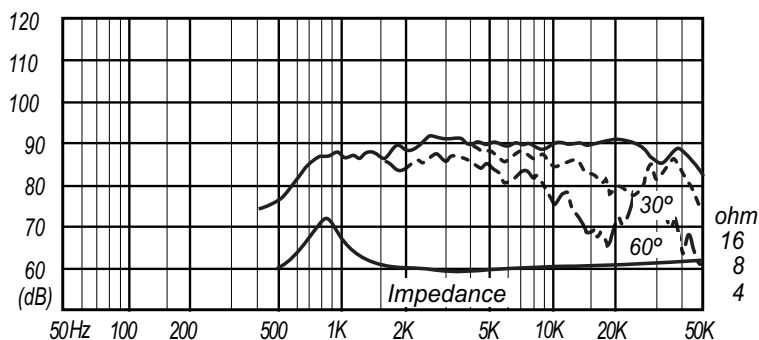

## Configuration Example

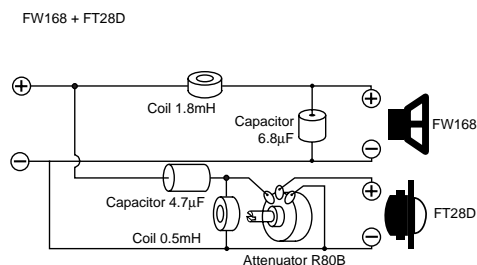

## Dimensions & Mounting Information

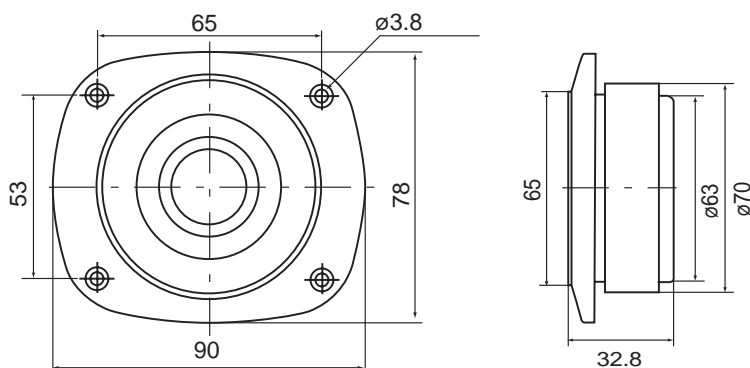

## Free Manuals Download Website

<http://myh66.com>

<http://usermanuals.us>

<http://www.somanuals.com>

<http://www.4manuals.cc>

<http://www.manual-lib.com>

<http://www.404manual.com>

<http://www.luxmanual.com>

<http://aubethermostatmanual.com>

Golf course search by state

<http://golfingnear.com>

Email search by domain

<http://emailbydomain.com>

Auto manuals search

<http://auto.somanuals.com>

TV manuals search

<http://tv.somanuals.com>