



Instruction Manual

**INFRARED GAS
ANALYZER**

TYPE: ZSP

INTRODUCTION

Congratulations on your purchase of Fuji Gas Analyzer. (Type:ZSP)

- Read this instruction manual carefully to ensure correct installation, operation and maintenance of the gas analyzer. Incorrect handling may lead to unexpected trouble or injury.
- The specifications of the gas analyzer is subject to change without prior notice for improvement.
- Modification of the gas analyzer without permission is strictly prohibited. Fuji is not responsible for any damage caused by modification made without permission.
- This safety precaution/operation manual should be kept by users of the analyzer.
- Keep this manual at hand for your future reference.
- This instruction manual must be given to final users.

Manufacturer : Fuji Electric Instrumentation Co., Ltd.
Type of product : Described in nameplate on main frame
Date of manufacture : See company nameplate on main unit.
Country of manufacture : Japan

Request

- Transcription of a part or the whole of this manual without permission is prohibited.
- The contents of this manual are subject to change without prior notice.



© Fuji Electric Systems Co., Ltd. 1997

Issued in June, 1997
Rev. 1st edition March, 2000
Rev. 2nd edition January, 2002

CAUTION ON SAFETY

Before use, carefully read this “Caution on safety” so that the product is usable correctly.

- The precautions given here are of great significance to safety. Therefore, they should be observed without fail. The precautions on safety are classified into ranks “Danger”, “Caution” and “Prohibition.”

 Danger	Items which pertains to incorrect handling that may lead to personal death or serious injury
 Caution	Items which pertains to incorrect handling that may lead to medium trouble, injury or physical damage
 Prohibition	Items which pertains to prohibition (DO NOT)

Installation, carrying, relocation and storage of gas analyzer

Danger

- This product is not explosion-proof. Do not use it in explosive gas-rich atmosphere. Otherwise, serious accidents such as explosion and fire may be caused.

Caution

- Installation, carrying and relocation must be made by a qualified contractor or your dealer. Incorrect installation results in falling accidents, electric shocks or fire accidents.
- The gas analyzer is heavy. Special care should be taken for installation to prevent trouble or injury due to falling or dropping of the analyzer.
- When the gas analyzer needs to be lifted, be sure to put on gloves. Do not hold it with bare hands to prevent injury.
- This product must be installed in a place that meets the conditions specified in the ‘instruction manual’ Use in a place that is outside the given installation conditions may cause an electric shock, fire or malfunction.
- During installation work, attention should be paid not to allow entrance of wire fragments, etc. into the product. Otherwise, a fire, trouble or malfunction may be caused.

Caution on wiring



Caution

- Request an installation company or your dealer to carry out wiring. If wiring is incomplete, shock hazard or injury may be caused.
- Class D grounding construction is mandatory. Otherwise, shock hazard may be caused.

< Caution for wiring company >

For preventing shock hazard, fire and injury, be sure to observe the following.

- Before wiring, be sure to turn off the primary power supply. If this is neglected, you may receive an electric shock.
- For grounding, use a 600 V-IV wire having a diameter of 2 mm² or more and an adequate dielectric strength.
- Connect the power supply which meets the rating of product. Connection of other power supply may cause a fire.
- Select the diameter of input and output wires, which matches the rated current of gas analyzer.
- Be sure to use solderless terminals for connection to the input and output terminal block.
- Use the terminal block for branching the output wire.
- Be sure to fix the input and output wires onto the floor, wall surface, etc. and use a protective device for wires.

Caution on use



Danger

- If you notice malodor or abnormal sound, stop the instrument immediately. If this is neglected, fire may occur.



Caution

- When the analyzer is to be operated after it has been left unused for a long time, the operating procedure is different from the normal stop/start procedure. It should be handled according to the procedure shown in the instruction manual to ensure its proper performance and to prevent trouble or injury.
- Do not operate the analyzer for a long time with its door left open to avoid entry of dust into the analyzer. Dust deposits will result in damage to the analyzer.

Caution on use



- Do not insert a rod or your finger into the fan (electronic cooler at ceiling), otherwise injury may be caused by the rotating blades.
- Do not touch metal, finger, etc. to the input and output terminal block of analyzer. Otherwise, shock hazard or injury may be caused.
- Smoking and use of fire/flame is prohibited in the vicinity of the gas analyzer. Otherwise, a fire may occur.
- A water-filled container such as a bucket should not be placed on the roof of the gas analyzer having indoor specifications. If such a container turns over, spilled water may cause shock hazard or burning inside the analyzer.

Caution on maintenance / inspection



- When handling standard gas such as calibration gas, read the instruction manual for the standard gas for correct handling. Special care should be taken when handling hazardous gas such as CO gas and the like to prevent poisoning.
- During maintenance or inspection, be sure to turn ON the ventilation fan in the analyzer to prevent poisoning due to gas leakage.
- When the gas filter of the analyzer is to be replaced or the washing unit needs maintenance, be sure to close the calibration gas valve. Especially, if the calibration gas valve is located at the sample gas inlet, the replacing or washing shall be done after closing the calibration gas valve to prevent poisoning or other trouble.



- The gas converter is heated to about 220°C. When the catalytic agent needs to be replaced, turn OFF the power for the converter and use heat-proof gloves about 30 minutes later.
 - When the fuse is blown off, check the cause of it and replace it with the same type of fuse having the same capacity to prevent electric shocks or other trouble.
 - When the analyzer is provided with a power leak relay, press the test button to confirm proper operation before making maintenance or inspection to prevent electric shocks.
 - Be sure to lock the door. Do not allow unauthorized persons to use the door key. Do not touch the door carelessly to prevent electric shocks and other trouble.
- ◎ The following items must be observed to prevent electric shocks or injury and to ensure safety.
- Take off metallic objects such as wrist watch before starting the work.
 - Do not touch the device with wet hands.

Others



Caution

- When trouble cannot be remedied even after following the instruction manual, contact your dealer or Fuji's service station (service engineer). Do not disassemble the device, as it results in electric shocks or injury.
- Do not use replacement parts which are not specified by makers. Use of these parts will not only provide the required performance but also result in damage or other trouble.
- Replacement parts used for maintenance must be handled as incombustible objects.

CONTENTS

INTRODUCTION	i
CAUTION ON SAFETY	ii
1. OUTLINE	1
2. SPECIFICATIONS	1
3. COMPOSITION	1
4. INSTALLATION	2
4.1 Selection of installation site	2
4.2 Selection of gas sampling location	2
4.3 Installation work	3
4.4 Connection of cables	3
4.5 Connection of pipes	3
5. DESCRIPTION OF EACH PART	5
6. PREPARATION FOR OPERATION	5
6.1 Injection of clean water	5
6.2 Supply of external power	5
6.3 Check of sample piping, exhaust piping, etc.	5
6.4 Airtightness test	6
6.5 Setting of temperature inside locker	6
6.6 Warm-up time	6
7. INDICATION/OPERATION PANEL	7
7.1 Name and description of each component of indication/operation panel	7
7.2 Function and indication of indication/operation panel	8
7.3 General operation of indication/operation panel	9
8. CALIBRATION	10
8.1 Kinds of standard gas	10
8.2 Preparation of standard gas	10
8.3 Calibration concentration setting (except zirconia O ₂ sensor)	12
8.4 Calibration concentration setting (zirconia O ₂ sensor)	14
8.5 Zero calibration (air point calibration in case of zirconia O ₂ sensor)	16
8.6 Span calibration (low concentration point calibration in case of zirconia O ₂ sensor)	17
8.7 Auto calibration	18
9. OPERATION	25
9.1 Operating procedure	25

10. MAINTENANCE	26
10.1 Routine maintenance and inspection	26
10.2 Periodic maintenance and inspection	28
10.3 Other maintenance and inspection	28
10.4 Concentration guarantee term of standard gas cylinder (for NO _x , SO ₂ , CO and O ₂ analyzer)	29
10.5 Maintenance of sampling device	29
10.6 Maintenance of zirconia O ₂ sensor	35
10.7 Others, major component figures	35
11. STANDARD ACCESSORIES AND SPARES	36
11.1 Standard accessories	36
11.2 Spares for 1 year (optional)	37
12. PROCESSING OF HEATING PIPE ENDS	38
12.1 Outline	38
12.2 End processing method	39
12.3 Check after piping	41
12.4 Clamp support	41
12.5 Specifications of tube trace	42
12.6 Specifications of heating pipe	42
13. TROUBLESHOOTING	43
13.1 Troubleshooting of instrument	43
13.2 Error codes and remedies	44
14. SPECIFICATIONS	45
CODE SYMBOLS	49
SAMPLING SYSTEM BLOCK DIAGLAM	50
OUTLINE DIAGRAM	52
CONNECTION DIAGRAM	53

1. OUTLINE

The infrared gas analyzer (ZSP) can continuously and accurately measure the concentration of gases such as NO_x, SO₂, CO, CO₂ and O₂ contained in the flue gas from a stationary generating source. The analyzer is available in both single-component and multi-component types depending on customer's specification. The actual analyzer may somewhat differ from the descriptions in this manual depending on the specifications demanded by each customer. For outline diagram, piping system, hardware configuration, specifications, standard accessories, spares and supplies, refer to the delivery specifications submitted individually.

Note: For details of the infrared gas analyzer, refer to the instruction manual INZ-TN2 ZRG separately prepared.

2. SPECIFICATIONS

Please refer to Chapter 14. Specifications. Note that the contents of the separately issued data sheet have priority.

3. COMPOSITION

(1) Gas sampling section	1 set (depending on customers' designation)
(2) Gas piping	1 set (depending on customers' designation)
(3) Accommodation locker	1
Infrared gas analyzer ZRG	1 or 2 (depending on customers' designation)
Zirconia O ₂ sensor ZFK 3, 4	1 (depending on customers' designation)
Converter ZDL	1 (for NO _x measurement)
Sampling	1 set
Standard gas, pressure regulator	1 set (depending on customers' designation)
Standard accessories	1 set
Spares and supplies for 1 year	1 set (depending on customer's designation)

4. INSTALLATION



Danger

- This product is not explosion-proof. Do not use it in explosive gas-rich atmosphere. Otherwise, serious accidents such as explosion and fire may be caused.



Caution

- Installation, carrying and relocation must be made by a qualified contractor or your dealer. Incorrect installation results in falling accidents, electric shocks or fire accidents.
- The gas analyzer is heavy. Special care should be taken for installation to prevent trouble or injury due to falling or dropping of the analyzer.
- When the gas analyzer needs to be lifted, be sure to put on gloves. Do not hold it with bare hands to prevent injury.
- This product must be installed in a place that meets the conditions specified in the 'instruction manual.' Use in a place that is outside the given installation conditions may cause an electric shock, fire or malfunction.
- During installation work, attention should be paid not to allow entrance of wire fragments, etc. into the product. Otherwise, a fire, trouble or malfunction may be caused.

There are a number of conditions which must be met for operating the gas analyzer stably over a long time.

4.1 Selection of installation site

A site which satisfies the following conditions should be selected for installation of the analyzer.

- (1) A place which is near the gas sampling location
- (2) A place which is not exposed to direct sunlight or heat radiated from a high temperature object (One which is not exposed to rain or water splash in case of indoor type)
- (3) A place which has a clean atmosphere (dust and corrosive gas not present)
- (4) A place with a minimum of vibration
- (5) A place where daily variation in temperature is minimum

4.2 Selection of gas sampling location

A place which satisfies the following conditions should be selected.

- (1) A typical place where the gases to be analyzed exist
- (2) Where the gases always flow without stagnation
- (3) A place easy of access for maintenance and inspection
- (4) Where the gases respond quickly to a change in the process operating conditions
- (5) Where variation in pressure, temperature, etc. is minimum

4.3 Installation work

For installation of the analyzer locker and the extractor, follow the piping instructions in Fig. 4-1 and the separately issued approval drawings (outline diagrams, sampling system diagram).

- (1) Countermeasures for cold climate
 - (a) Freeze prevention of gas piping
 - (b) Freeze prevention of drain pot
 - (c) Freeze prevention of bypass and drain pipes
- (2) Countermeasurement for vibration

When installing in a place where vibration is considerable, the locker should be floated on antivibration rubber pads.

4.4 Connection of cables



Caution

- Request an installation company or your dealer to carry out wiring.
If wiring is incomplete, shock hazard or injury may be caused.
- Class D grounding construction is mandatory. Otherwise, shock hazard may be caused.

<Caution for wiring company>

For preventing shock hazard, fire and injury, be sure to observe the following.

- Before wiring, be sure to turn off the primary power supply. If this is neglected, you may receive and electric shock.
- For grounding, use a 600 V-IV wire having diameter of 2 mm² or more and an adequate dielectric strength.
- Connect the power supply which meets the rating of product. Connection of other power supply may cause a fire.
- Select the diameter of input and output wires, which matches the rated current of gas analyzer.
- Be sure to use solderless terminals for connection to the input and output terminal block.
- Use the terminal block for branching the output wire.
- Be sure to fix the input and output wires onto the floor, wall surface, etc. and use a protective device for wires.

The lead-in for AC power cables and outlet for signal wires are provided at the bottom of the analyzer or else at the specified place. Connect AC power cables and output signal wires according to the separately issued wiring diagrams.

Note: Avoid connecting the analyzer power supply near devices such as high-frequency heating furnace or electric welder which greatly disturb the power waveform, and avoid sharing the same power lines with such devices. Class D grounding construction (100W ground resistance) is required.

4.5 Connection of pipes (refer to piping instructions in Fig. 4-1 and separately issued approval drawings)

- (1) Connect gas pipe between the gas extractor and the analyzer inlet (sample gas inlet). Use a joint, etc. for $\phi 10/\phi 8$ Teflon pipe when connecting to ensure there will be no leakage.
- (2) Additionally tighten the joint section if necessary

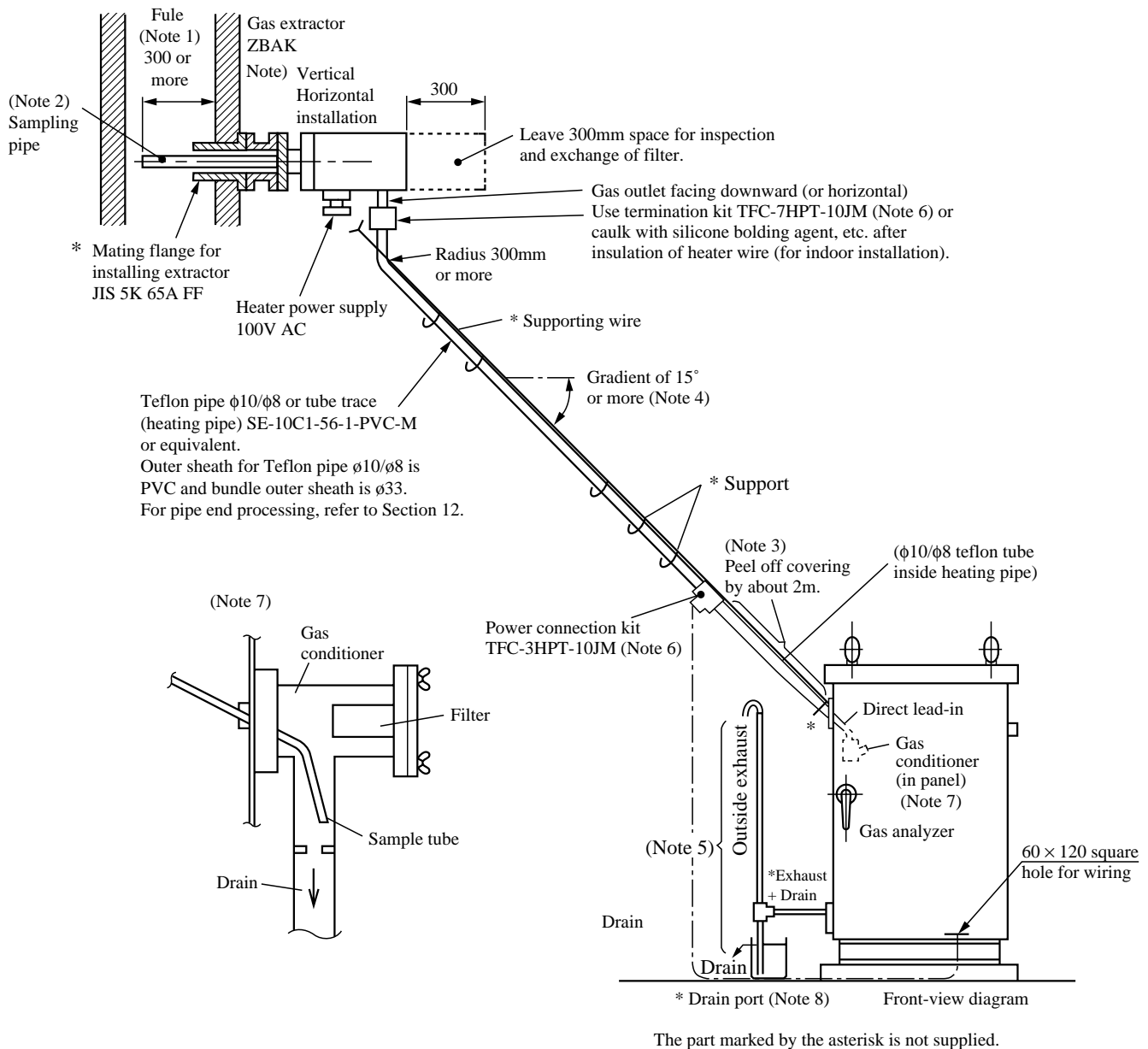

Fig. 4-1 Piping procedure

- Note 1)** To prevent aspiration of leaked air
- Note 2)** Install so that pipe end comes to nearly center of flue and is at right angle to the gas flow.
- Note 3)** Peel off heating pipe by about 2m in order to air-cool measured gas.
- Note 4)** Provide an inclination of 15° or more on the gas pipe so that drain will not accumulate in the event of power failure, etc.
- Note 5)** Exhaust and drain share the same output. In the case of indoor installation, provide a drain pot and carry out drain separation, and exhaust air outside (pipe inner diameter should be Ø8 or more).
- Note 6)** Use this when utilizing a heating pipe. (Maker : Fujikin, Japan)
- Note 7)** The gas pipe (Ø10/Ø8 teflon tube) should be inserted directly into the gas conditioner.
- Note 8)** In outdoor application or in a cold district, protect the drain pot and pipes with a heat insulating material, etc. to prevent drain from freezing in winter.

5. DESCRIPTION OF EACH PART

Please refer to Chapter 14 specification attached at the end of the manual.

6. PREPARATION FOR OPERATION

6.1 Injection of clean water

Inject clean water through the filter or air aspiration port until it overflows from the gas conditioner.

6.2 Supply of external power

Supply external power to the analyzer. And check the connections with output signal wire, etc. The external power supply should be.....

100V±10% AC,

50/60 Hz ±1%,

with power consumption of 0.9kVA max. (excluding heating pipe).

Check with reference to the separately issued approval diagrams.

6.3 Check of sample piping, exhaust piping, etc.

Check the connection of the sample piping and if necessary, provide exhaust piping + drain piping (Pipes with inner diameter of ø8 or more for both). When sample will be dispersed upward, then branch and water-seal the exhaust pipe for the purpose of drain separation. Be sure to disperse the exhaust into the atmosphere.

Make checks with reference to the piping instructions in Fig. 4-1 and the separately issued gas analyzer diagram.

6.4 Airtightness test

(1) Piping inside panel

Since airtightness is confirmed during tests before shipment, an Airtightness test during trial run is usually unnecessary. When a long time has passed after shipment, then carry out the following procedure.

- (a) Close the drain port.
- (b) Connect standard gas to the sample gas inlet.
- (c) Connect the transparent tube of the conditioner air suction port (see Fig. 10-1) vertically (in place of a manometer).
- (d) Flow standard gas gradually, and after reaching a pressure of about 1961Pa, close the needle valve of the pressure regulator.
- (e) Check the water level at the air suction port of the conditioner, and if the drop in the level in less than 147Pa/min, then the error due to insufficient airtightness is negligible.
- (f) If a leak is present when measuring a harmful gas, make a check by applying soapy water to the normal pressure section while aspirating outside air.

(2) Piping outside panel

Thoroughly check the tightened condition of pipe joints. If necessary, apply pressure from the extractor outlet side and make a test as in the preceding item (1).

- (3) If the airtightness is insufficient, make a test on each section, find the faulty location and make it completely airtight. If the faulty location is before the aspirator, then air enters the gas pipe midway to cause a drop in the indication.

6.5 Setting of temperature inside locker

Turn on power supply to a space heater depending on the ambient temperature. Ventilation fan should always be turned ON.

6.6 Warm-up time

Turn ON the auto breaker.

(1) Gas extractor

Turn ON the power switch and warm up the extractor for at least 1 hour.

(2) Heating pipe (option)

Turn ON the power supply auto breaker of heating pipe and warm up the pipe for at least 1 hour.

(3) Electronic gas cooler

Turn ON the power switch and warm up for at least 10 minutes.

(4) NO₂/NO converter (option)

Turn ON the switch, set the temperature regulator at 220°C, and warm up for about 30 minutes until indication of the temperature reaches 220±2°C. 200°C for a NO/CO (+ O₂) analyzer

(5) Analyzer

Turn ON the power switch and carry out warm-up.

Infrared gas analyzer: about 8 hours

Zirconia O₂ sensor: about 30 minutes

7. INDICATION/OPERATION PANEL

7.1 Name and description of each component of indication/operation panel

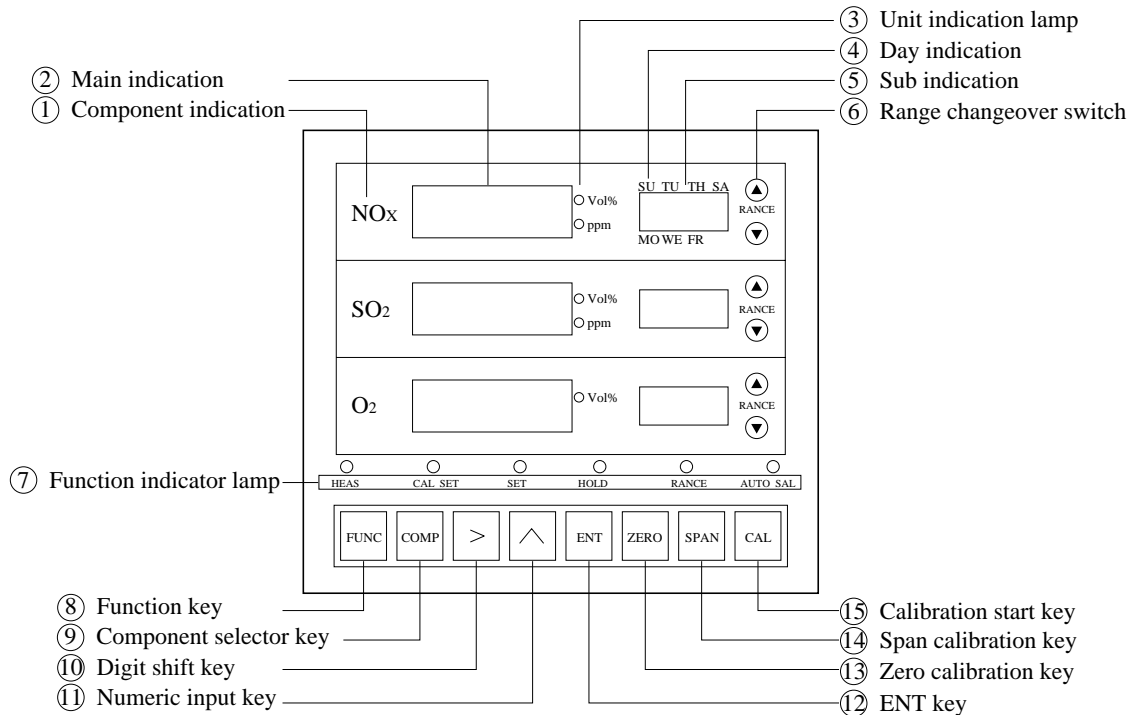

(Three component of NOx, SO₂ and O₂ are indication in this figure.)

Part Name	Description
① Component indication	Indicates kind of gas measured.
② Main indication	Indicates measured concentration. Also indicates various set-points for alarm function, auto calibration function (option), etc.
③ Unit indication lamp	Indicates units of measured gas concentration.
④ Day indication	Indicates current day or day of starting by means of bar in auto calibration (option) setting mode. Indication SU MO TU WE TH FR SA Day Sun. Mon. Tue. Wed. Thu. Fri. Sat.
⑤ Sub indication	Indicates measuring range, error code, various set points, etc.
⑥ Range changeover key	Used when changing the range. High range is set when pressing ▲ and low range is set when pressing ▼.
⑦ Function indicator lamp	Relevant lamp lights up when following functions are set. MEAS: Lights up in measuring status. CAL SET: Flashes in calibration concentration setting mode. ALM SET: Flashes in alarm setting mode. HOLD: Flashes in hold setting mode or lights steadily while hold function is activated. RMT RANGE: Flashes in remote range setting mode or light steadily while remote range function is activated. AUTO CAL: Flashes in auto calibration setting mode or lights steadily while auto calibration function is activated.
⑧ Function key	Setting mode is changed at each press of this key (Refer to Section 5).
⑨ Component selector key	Set component is changed for each setting mode.
⑩ Digit shift key	Shift is made from highest toward lowest digit at each press of this key.
⑪ Numeric input key	Selected digit is incremented at each press of this key.
⑫ ENT key	By pressing this key after setting, the set contents are memorized and becomes valid.
⑬ Zero calibration key	Used for zero point calibration. (Lamp flashes in zero calibration mode.)
⑭ Span calibration key	Used for span calibration (Lamp flashes in span calibration mode.)
⑮ Calibration start key	Start key for manual calibration. Zero is calibrated by pressing [ZERO] and [CAL] keys. Span is calibrated by pressing [SPAN] and [CAL] keys. (CAL lamp lights steadily during calibration).

7.2 Function and indication of indication/operation panel

This panel consists of the following functions.

Key	Function	Main indication	Sub indication	Function indication lamp
▶ FUNC	Measuring mode	Measuring value	Range	MEAS lamp lights
↓				
FUNC	Setting mode			
↓				
FUNC	Calib.conc.setting	Calb.conc.	Range	CAL SET lamp lights
↓				
FUNC	Alarm setting (option)	Lo2P	Alarm value	ALM SET lamp flickers*
↓				
FUNC	Hold setting	Hold	ON or OFF	HOLD lamp flicker
↓				
FUNC	Remote range setting (option)	r.r. R0	ON or OFF	RMT RANGE lamp flickers*
↓				
FUNC	Current time setting	Hr.min.	Day	Auto CAL lamp flickers
↓				
FUNC	Auto clib.start time setting	HR.min.	Day	AUTO CAL lamp flickers
↓				
FUNC	Auto calib.cycle setting	CYCL	Time	AUTO CAL lamp flickers
↓				
FUNC	Calib. gas flow time setting	F.SEC	Time	AUTO CAL lamp flickers*
↓				
FUNC	Calib. gas flow time setting	FLNo.	Mode No.	AUTO CAL lamp flickers*
↓				
FUNC	Auto calib.changeover	A.CAL	ON or OFF	AUTO CAL lamp flickers
↓				
FUNC	Key lock changeover	LOC.	ON or OFF	*
ZERO	Zero calibration	Measured value	Range	Zero key indication flickers
ZERO	Span calibration	Measured value	Range	Span key indication flickers

- When the setting mode is assumed, the analog output signal is held at the value just before entering this mode.
- When optional functions are not provided, the contents of these functions are not indicated.
- * Refer to the instruction manual of the infrared gas analyzer for the items marked by the asterisks.

7.3 General operation of indication/operation panel

The measuring mode is assumed when power is turned ON. The gas concentration appears on the main indication, while the range being used appears on the sub indication.

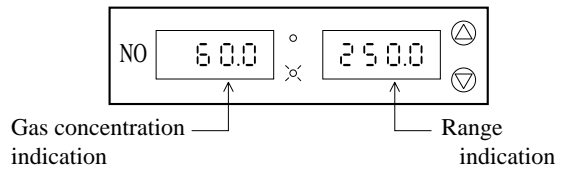

Advice on Operation

☆ When selecting the range

In the setting status, as shown in the figure at the right, the high range is selected when Δ key is pressed, while the low range is selected when ∇ key is pressed.

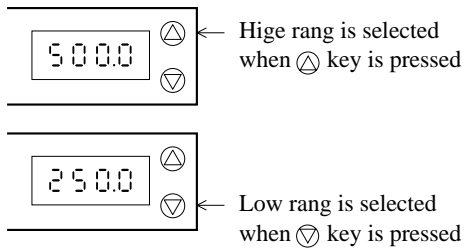

☆ When selecting the gas component

In the setting status, as shown in the figure at the right, the gas component can be set by pressing **COMP** key.

Example: When **COMP** key is pressed while the 1st component is flashing, the flashing moves to the 2nd component (figure at right). The setting for the 2nd component is now changeable.

* The 1 component type analyzer is not provided with **COMP** key.

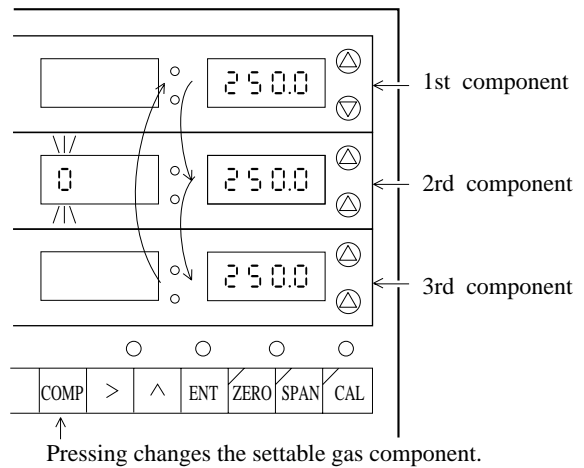

☆ For releasing zero or span

If a mistake has been made in zero or span calibration, then perform a reset in the following way.

The figure at the right shows an example. If **SPAN** key has been pressed mistakenly instead of **ZERO** key, then press **SPAN** key again. Calibration is released.

If **ZERO** key has been pressed mistakenly instead of **SPAN** key, the press **ZERO** key again. Calibration is released.

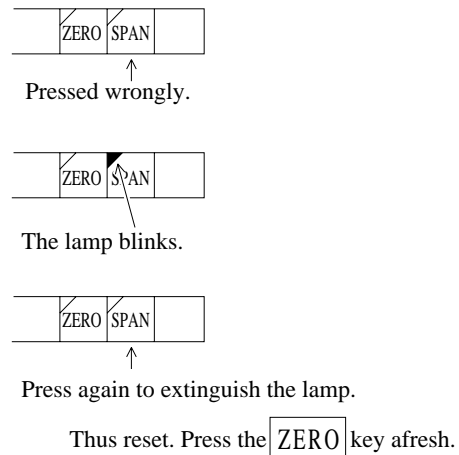

8. CALIBRATION



Danger

- When handling standard gas such as calibration gas, read the instruction manual for the standard gas for correct handling. Special care should be taken when handling hazardous gas such as CO gas and the like to prevent poisoning.

8.1 Kinds of standard gas

8.1.1 When not using zirconia O₂ sensor

- (1) Zero gas: N₂ or atmospheric air/instrument air depending on specification (when without verification stipulated in the laws for measurement and weighing)
- (2) Span gas: Gas of 90% or more full scale for each component, remainder is N₂ (span gas for low range will be delivered unless otherwise specified)

8.1.2 When using zirconia O₂ sensor

- (1) Zero gas: Air (Span gas of the O₂ analyzer in the laws for measurement and weighing).
- (2) Span gas: 1 to 2% O₂, remainder is N₂. (Zero gas of the O₂ analyzer in the laws for measurement and weighing).
Gas of 90% or more full scale for other than zirconia O₂ sensor, remainder is N₂.

Note: For separately calibrating the low and high ranges of the zirconia O₂ sensor, supply 9 to 10% O₂ and the remainder N₂ for the low range (10%) and use air for the high range (25%).

8.2 Preparation of standard gas

The standard gas to be used for calibration is delivered in a separate package from the locker.

Check the kind of standard gas to be used according to the sampling system diagram, and set it at the prescribed location.

Before starting calibration, attach a pressure regulator to the standard gas.

8.2.1 How to mount pressure regulator for standard gas cylinder

- (1) Before mounting a pressure regulator to the gas cylinder, clean the gas cylinder adapter. Entry of dust into the pressure regulator may result in gas leaks.
- (2) If packing is not inserted in the mounting nut for the cylinder or it is damaged, replace it with supplied spare one.
- (3) Use a spanner of a proper size, fasten the cylinder mounting nut to the gas cylinder. Mount supplied joint to the outlet according to Item "Sampling system block diagram".
- (4) Loosen the pressure controls and then tighten the outlet controls.
- (5) Open a valve of the gas cylinder, and the pressure gauge on the high pressure side indicates a pressure of the gas cylinder by flowing gas into the pressure regulator.
- (6) Turn the pressure controls clockwise to increase the secondary pressure; adjust the pressure controls so that a pressure gauge on the low pressure side reads 30 kPa.
- (7) Open the outlet controls to release gas.

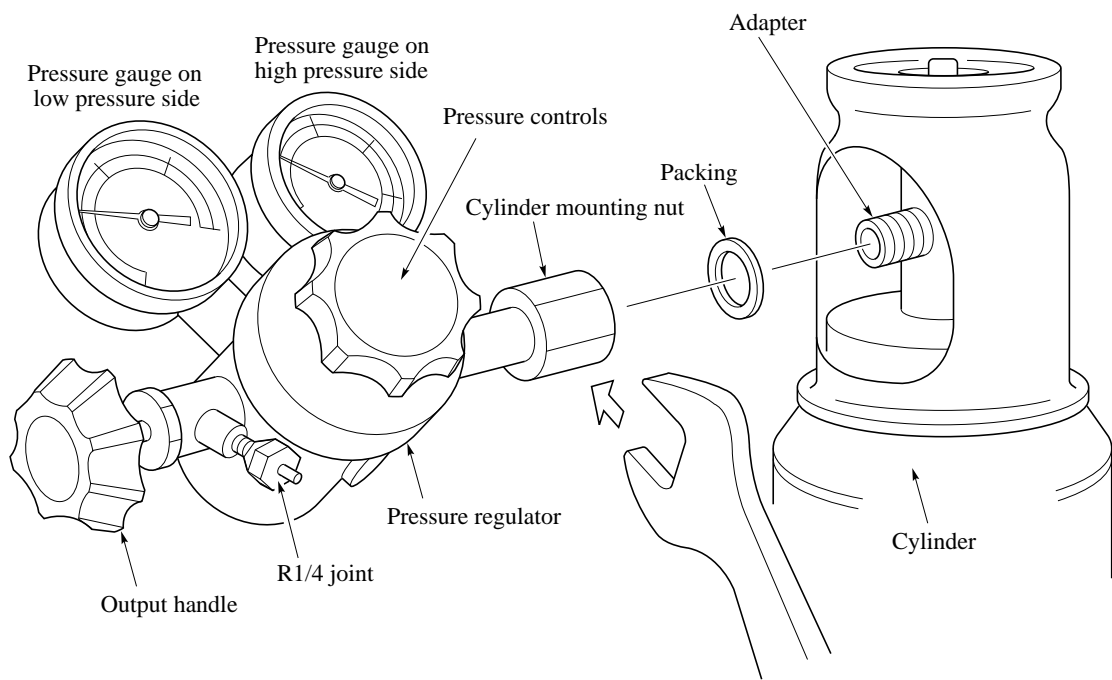

Fig. 8-1 Pressure regulation for standard gas cylinder

8.3 Calibration concentration setting (except zirconia O₂ sensor)

Set a span value for the calibration concentration setting. (Zero point calibration concentration is fixed at zero.)

Set the calibration gas concentration (span value).
When **FUNC** key is pressed in the measuring status, the previously set span value will appear on the main indication.

The CAL SET LED of the function indicating lamps will flicker.

By pressing the **>** key, the highest digit of the main indication for the 1st component will flicker, and the span value can not be set.

Select a range with the **▲** **▼** keys.

After selecting the range, set a span value in this status.

The numeric value will be incremented by pressing **▲** key.

The digit to be set can be selected by pressing **>** key.

For selecting the 2nd and subsequent components and the range, press the **>** key and while the main indication for the 1st component is flickering, press the **COMP** key and then the main indication for the component to be set will flicker. Now press the **▲** **▼** keys to select the range to be set.

When the span value has been set, press the **ENT** key. Setting operation is completed.

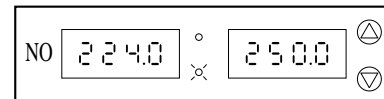
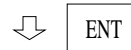
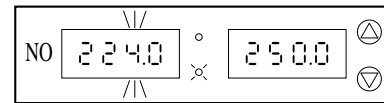
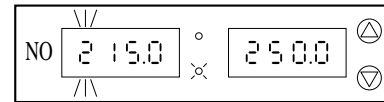
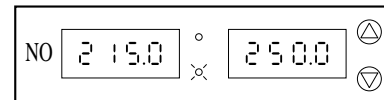
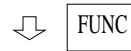
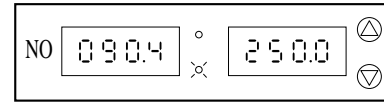

[When adjusting for each range]

(Simultaneous calibration of H and L ranges has been factory-set).

Perform setting in the following way.

By pressing **CAL** key while the highest digit of the main indication for the 1st component is flickering, then 'S.CAL' will appear on the main indication and '!' will appear on the sub indication.

Press **^** key and ! will change to 0.

= Meaning of set values =

- 0**: The calibration is valid only for the selected range, and zero and span calibration can be made independently for each range.
- !**: By conducting zero and span calibration for one range, the calibration will be done automatically for the other ranges as well.

When the selection has been finished, press the **ENT** key. Setting operation is completed.

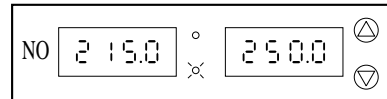
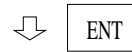
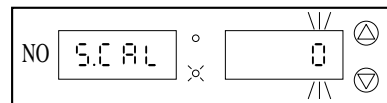
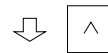
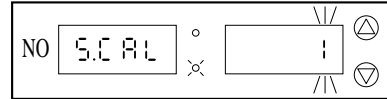
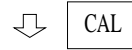
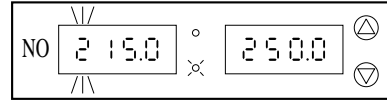

8.4 Calibration concentration setting (zirconia O₂ sensor)

A zirconia O₂ sensor sets the zero (air) point (span point stipulated in the laws for measurement and weighing) of the O₂ analyzer. For the density of calibration gas to be used, refer to “8.2 Preparation of standard gas”.

☆Setting of calibration concentration for zero (air) point (zero stipulated in the laws for measurement and weighing)

By pressing the **FUNC** key in the measuring status, the calibration concentration previously set for the zero (air) point will appear on the main indication.

The CAL SET LED of the function indicating lamps will flicker.

By pressing the **>** key, the higher digit of the main indication of the O₂ analyzer will flicker and zero point setting is enabled.

Press the Δ ∇ keys to select a range.

The numeric value will be incremented by pressing **^** key. The digit to be set is selected by pressing the **>** key.

Setting ranges are 20.2 to 21.9 Vol. % for high range and 7.0 to 21.9 Vol. % for low range.

Set the air concentration for both high and low range.^{Note)}

Press the **ENT** key after setting the zero point. Setting operation is completed.

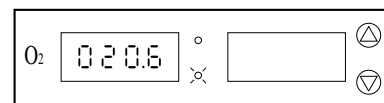
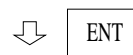
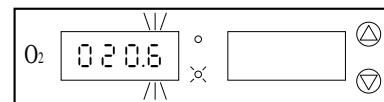
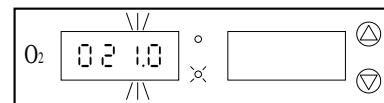
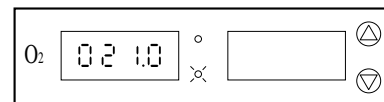
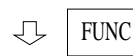
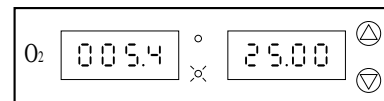

Note: When using air for the high range and 9 to 10 Vol. % O₂/N₂ for the low range, set the density for each range.

When viewing from the zirconia O₂ sensor side, the air point corresponds to the zero point. Therefore, calibration should begin with the air point.

Also, since the air point and low concentration point can be calibrated by the zero calibration key and span calibration key, respectively, the air point and low concentration point are regarded as the zero and span in this manual.

☆Setting of span calibration concentration (zero point stipulated in the laws for measurement and weighing)

Press the **CAL** key in the status where the digit of the O₂ analyzer main indication is flickering via the zero (air) point calibration concentration setting.

The previously set span value will now appear on the main indication.

The 'CAL SET LED' of the function indicating lamps will flicker.

Then, press the **COMP** key and the highest digit of the O₂ analyzer main indication will flicker and the span value is now settable.

Press the **▲▼** keys to select a range.

When the range has been selected, set a span value in this status.

The numeric value will be incremented by pressing the **▲** key.

Press the **▶** key and the digit to be set can be selected.

Press the **ENT** key after setting the span value. Setting operation is completed.

== Setting of each component ==

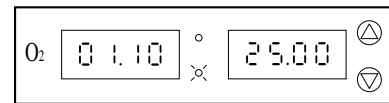
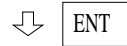
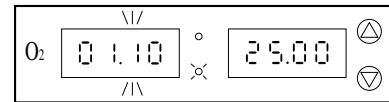
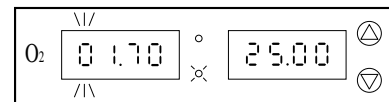
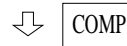
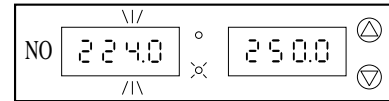
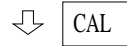
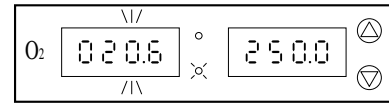

8.5 Zero calibration (air point calibration in case of zirconia O₂ sensor)

This is used for adjusting the zero point.

Flow the zero gas (0.3 ℓ /min.) by adjusting the needle valve of pressure regulator and wait until the indication stabilizes.

When the Zirconia O₂ sensor is used, use air.^{Note)}

When the indication has stabilized, select the measuring range to be calibrated by using the Δ ∇ keys.

When using a multi-component analyzer, all the components undergo zero calibration simultaneously at the selected range.

Press the ∇ ZERO key, and ∇ ZERO key lamp will flicker.

Next press the Δ CAL key and conduct zero calibration.

The Δ CAL key lamp lights steadily during calibration.

Since the measuring status is resumed after the calibration, carry out the calibration for other ranges if necessary.

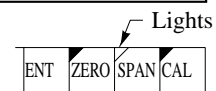
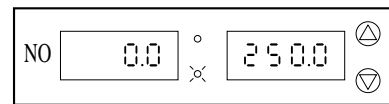
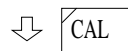
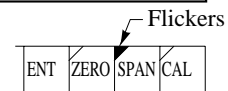
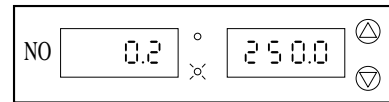
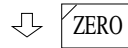
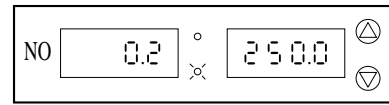

(Lamp is turned off after calibration)

Note: When using different gases for the low and high ranges, apply 9 to 10 Vol. % O₂/N₂ which has been set for the low range.

When the function for automatic calibration is provided, the solenoid valve turns on and calibration gas flows upon pressing the ∇ ZERO key.

8.6 Span calibration (low concentration point calibration in case of zirconia O₂ sensor)



Carry out span calibration by flowing calibration gas at the concentration set as a span value.

Flow the calibration gas (0.3 ℓ /min.) by adjusting the needle valve of pressure regulator. Wait until the indication stabilizes, and then conduct span calibration.



Press the  key and the  key lamp flickers.

In the case of a multi-component analyzer, the main indication will flicker for the components which can be calibrated.

Press the COMP key and the settable gas component will change.

When the gas component has been determined, press the   keys and select a range.

Note: The lamp will not flicker in the case of a single-component analyzer.

Next press the  key and conduct span calibration. The  key lamp lights steadily during calibration.

Since the measuring status is resumed after calibration, continue the calibration for each component and each range.

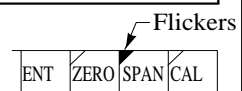
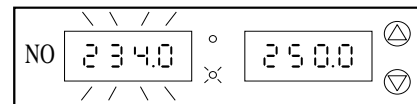
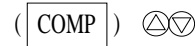
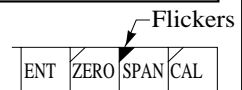
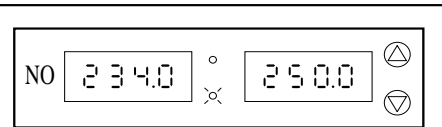
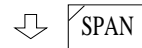
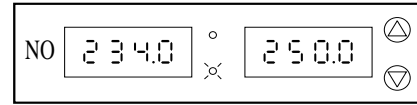

(In case of a multi component analyzer)

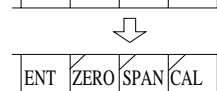
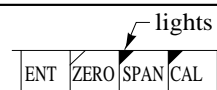
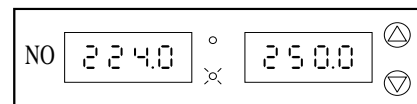
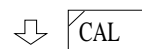

(Lamp is turned off after calibration)

Note: On the low range of zirconia type O₂ sensor, when zero gas is calibrated with 9 to 10 Vol. % O₂, the zero and span calibrations interfere with each other. So, each calibration should be repeated a few times.

When the function for automatic calibration is provided, the solenoid valve turns on and the span gas for the selected component flows upon pressing the SPAN key.

8.7 Auto calibration

In this analyzer, the signals from the input/output terminals on the upper can be used for driving an external solenoid valve and introducing standard gas, whereby zero point and span can be calibrated automatically. The auto calibration is done according to 8.7.1 Current time setting, 8.7.2 Auto calibration start time setting, 8.7.3 Auto calibration cycle setting, 8.7.4 Auto calibration ON/OFF setting and 8.7.5 Output Hold setting at Calibration.

Cautions on operation

1. When the auto calibration start time is reached during key operation, the auto calibration is given priority and is started. All key operation will be invalid until the auto calibration is finished.
2. To forcibly interrupt the auto calibration in progress, press both the **ENT** and **CAL** keys simultaneously. After the forcible interrupt, the measuring mode is resumed and all the keys are operable. Although the current auto calibration will be passed over, it will be started from the initially set cycle from the next time onward.

Example: When auto calibration is set for 3 hour intervals starting from 8:00 a.m.

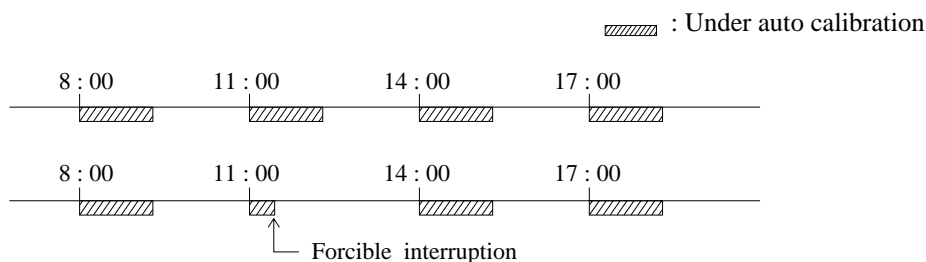

3. Key operation is possible while calibration is not under way with the auto calibration function set. Therefore all settings (of span, hold, remote range, time, etc.) including manual calibration can be made. But note that if the wrong time is set on the clock, the auto calibration will not be started at the correct time.
4. Auto calibration is able to start by applying remote start input signal, 5V DC longer than 100msec, to remote start input terminals. In this case, auto calibration will start independent to its ON/OFF setting. (Calibration starts at the trailing edged of signal.)
5. When measuring 4 components, or NO_x , SO_2 , CO and O_2 (with 2 infrared gas analyzers), the automatic calibration cycle should be set on the CO/O_2 analyzer side and the automatic calibration of NO_x/SO_2 analyzer should be turned OFF. After the automatic calibration of CO/O_2 analyzer, the automatic calibration of NO_x/SO_2 analyzer will be started.

Example of auto calibration time chart for 4-component measurement

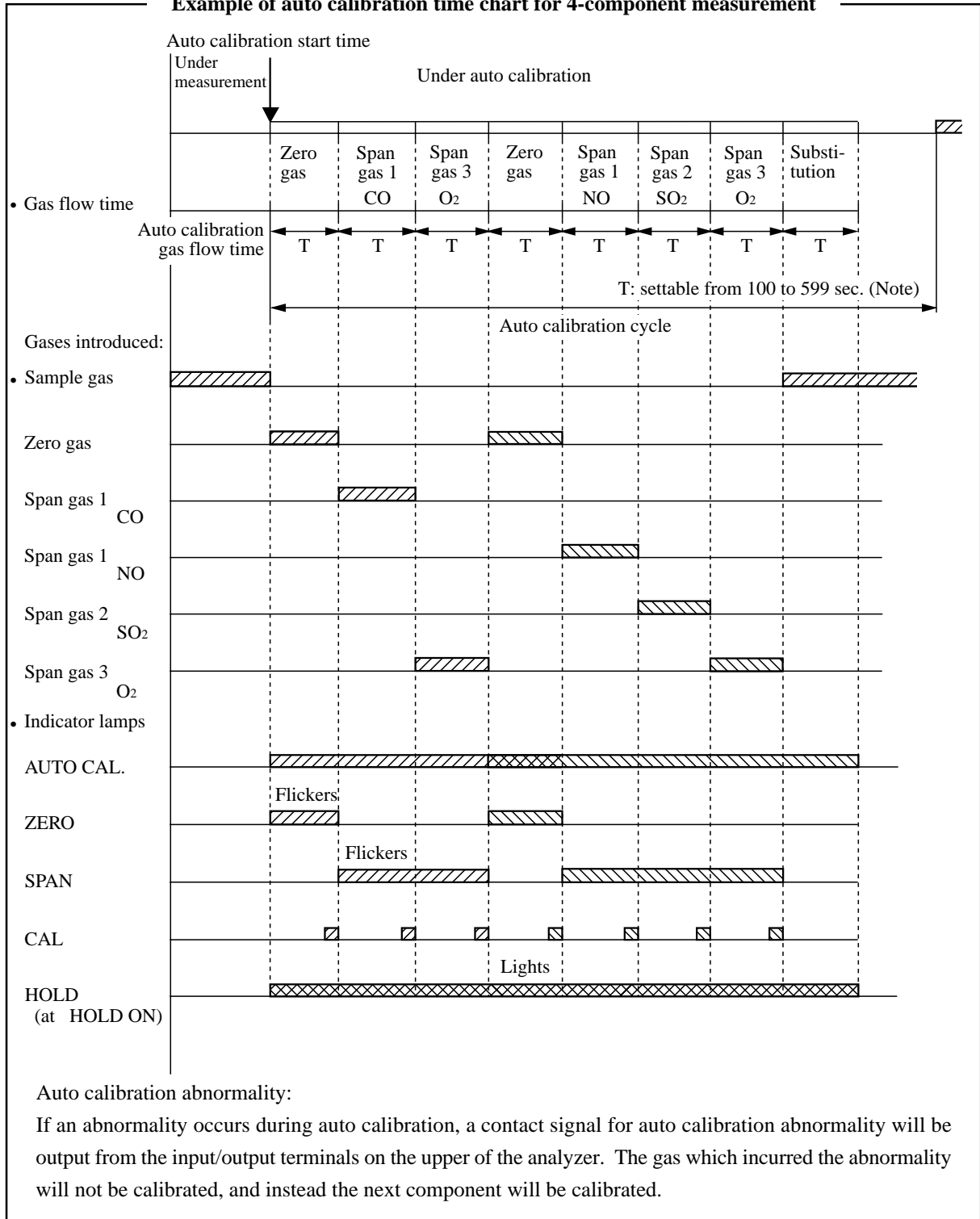

Note: Usually, T is set at 360 sec. for measurement including SO₂, and at 180 sec. for other measurements.
For change of setting, refer to the separate instruction manual of infrared gas analyzer.

8.7.1 Current time setting

Set the current time and day of the week.

Press the **FUNC** key in the measuring status.

The AUTO CAL LED of the function indicating lamps will flicker.

The main indication shows the hour and minute via a 24-hour indication and the decimal point flickers.

A '-' bar lights up at the relevant weekday on the sub indication.

Indication	SU	MO	TU	WE	TH	FR	SA
Day	Sun.	Mon.	Tue.	Wed.	Thu.	Fri.	Sat.

Press the **>** key and the time is now settable.

The highest two digits of the main indication will flicker.

The numeric value is incremented by pressing the **^**.

Press the **>** key and the digit can be selected.

After the time setting, press **>** key and the day is settable on the sub indication.

The bar indication will flicker.

Press the **^** key and the bar will shift.

Press the **ENT** key when the time and day setting is finished. The data are saved.

Time starts from the point where **ENT** key is pressed.

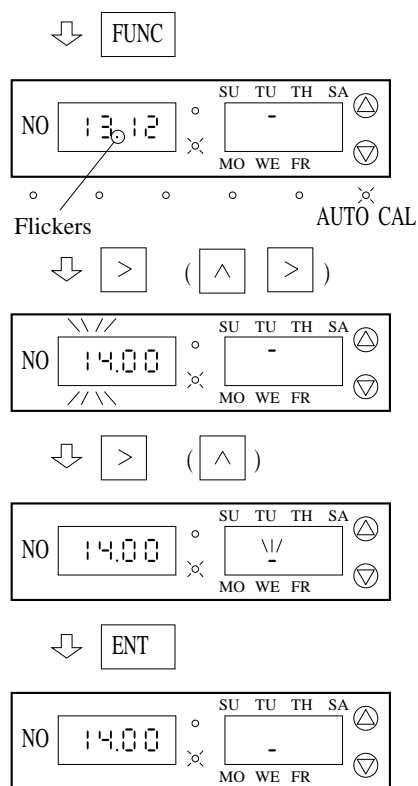

8.7.2 Auto calibration start time setting

When **FUNC** key is pressed at the current time indication, the auto calibration start time and day will appear on the main and sub indications.

The AUTO CALLED of the function indicating lamps will flicker. In the case of start time, the decimal point on the main indication will light steadily.

Press the **>** key and the auto calibration start time is settable, so set a start time on the main indication.

The numeric value is incremented by pressing the **^** key.

Press the **>** key and the digit can be selected.

After setting the calibration start time, press the **>** key and the calibration start day can be set on the sub indication.

The bar indication will flicker.

Press the **^** key and the bar will shift.

The auto calibration start time is settable up to one week ahead.

When the auto calibration start time and day have been set, press the **ENT** key. The data are saved.

When the auto calibration at the set time is finished, the next auto calibration start time will be set automatically.

To confirm the next auto calibration start time, then carry out this operation and check the indication.

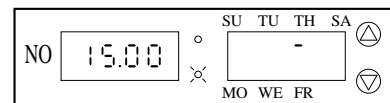
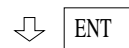
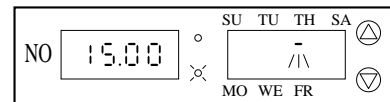
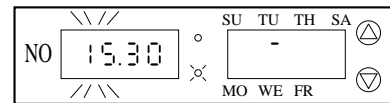
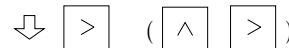
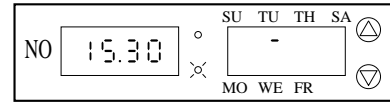
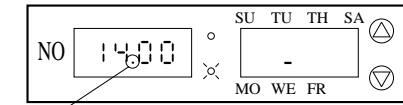

Note: When the auto calibration start time has been set, then set the auto calibration cycle.

8.7.3 Auto calibration cycle setting

The calibration cycle is settable in either 'days's or 'hours'.

Press the FUNC key at the calibration start time indication and 'CYCL' will appear.

The AUTO CAL LED of the function indicating lamps will flicker.

Press the > key and the auto calibration cycle is settable. The highest digit on the sub indication will flicker. Select either 'days' or 'hours' by pressing the ^ key.

'D' appears on the sub indication when selecting 'days' and 'H' appears when selecting 'hours'.

Press the > key and the calibration cycle and be set in the lower digits of the sub indication.

The numeric value is incremented by pressing the ^ key.

Press the > key and the digit can be selected.

Day is settable in a range of 1 to 7 days. Hour is settable in a range of 1 to 99 hours.

Note

If '0 0' (hours) is set, it will be automatically set to '1'(hours).

Press the ENT key when the calibration cycle has been set. The data are saved.

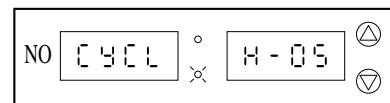
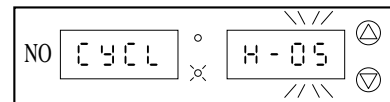
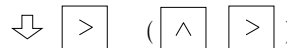
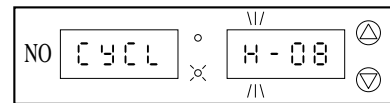
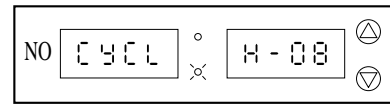
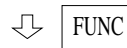
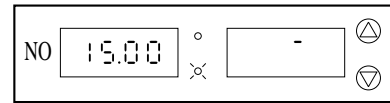

AUTO CAL

8.7.4 Auto calibration ON/OFF setting

Select whether or not to carry out auto calibration.

Set to 'OFF' when calibration will not be made.^(Note)

Press the **FUNC** key at the calibration gas flow mode indication and 'A.CAL' will be appear.

The AUTO CAL LED of the function indicating lamps will flicker.

Press the **>** key and auto calibration ON or OFF can be set.

Select either 'on' or 'OFF' on the sub indication by pressing the **^** key.

When the auto calibration ON/OFF setting is finished, press the **ENT** key. Setting operation is completed.

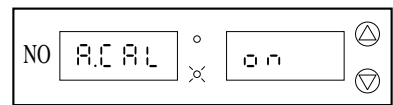
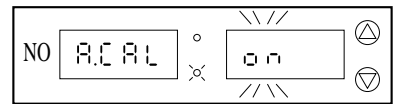
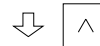
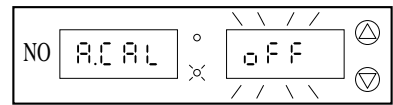
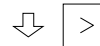
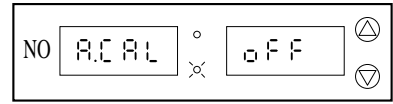
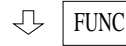
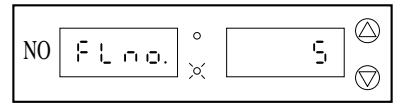

AUTO CAL

Note: In case of 4-component (NO_x, SO₂, CO and O₂) analyzer, be sure to turn OFF the automatic calibration of NO_x/SO₂ analyzer.

8.7.5 Setting of output hold at calibration

This is used when calibrating for holding the output signal at the value just before entering calibration. (The indication is not held.)

The hold function is settable for each component.

Press the **FUNC** key in the measuring status and 'Hold' will be indicated.

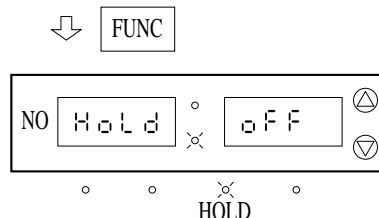

The HOLD LED of the function indicating lamps will flicker.

Press the **>** key and the hold function will be settable.

The sub indication will flicker.

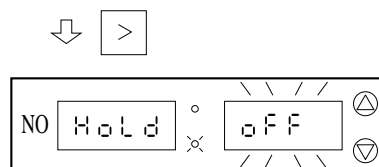

Select hold 'ON' or 'OFF' by pressing the **^** key.

Press the **ENT** key after setting the hold function. Setting operation is completed.

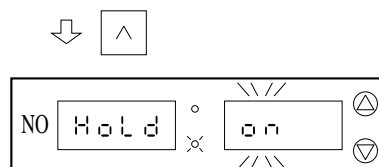

Setting is valid for all the components.

At hold ON, the HOLD of the function indicating lamps will light steadily while the hold function is activated.

At hold OFF, these lamps will go off.

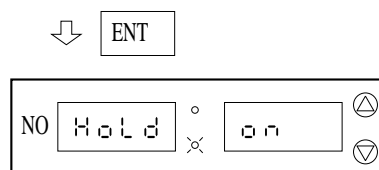

In case of automatic calibration, output is held while the automatic calibration lamp is lit.

In case of manual calibration, output is held for about half an hour after completion of calibration.



For canceling the output hold forcibly, turn off the hold setting once.

Note 1: When measuring 4 components, or NO_x, SO₂, CO and O₂ (with 2 infrared gas analyzers), output is held by using the external hold function at the time of automatic calibration.

Note 2: In the setting mode, output is held indifferently to the ON/OFF status of hold setting.

Note 3: In case the analyzer is equipped with a maintenance switch, output is held while the switch is turned on.

9. OPERATION

 Danger
<ul style="list-style-type: none">• If you notice malodor or abnormal sound, stop the instrument immediately. If this is neglected, fire may occur.
 Caution
<ul style="list-style-type: none">• When the analyzer is to be operated after it has been left unused for a long time, the operating procedure is different from the normal stop/start procedure. It should be handled according to the procedure shown in the instruction manual to ensure its proper performance and to prevent trouble or injury.• Do not operate the analyzer for a long time with its door left open to avoid entry of dust into the analyzer. Dust deposits will result in damage to the analyzer.
 Prohibition
<ul style="list-style-type: none">• Do not insert a rod or your finger into the fan (electronic cooler at ceiling), otherwise injury may be caused by the rotating blades.• Do not touch metal, finger, etc. to the input and output terminal block of analyzer. Otherwise, shock hazard or injury may be caused.• Smoking and use of fire/flame is prohibited in the vicinity of the gas analyzer. Otherwise, a fire may occur.• A water-filled container such as a bucket should not be placed on the roof of the gas analyzer having indoor specifications. If such a container turns over, spilled water may cause shock hazard or burning inside the analyzer.

9.1 Operating procedure

- (1) Check if all the preparation for operation have been completed.
- (2) Press the range selector switch on the indication/operation panel to select a range to be used.
- (3) Press the function key "FUNC" on the indication/operation panel to light up the "MEAS" function indicator lamp.
- (4) Turn on the aspirator power supply and confirm that the ball of flow meter is at 0.4 ℓ /min. Prescribed flow rate may be 0.5 ℓ /min. So it should be checked in the piping system diagram separately presented.

10. MAINTENANCE



Danger

- When handling standard gas such as calibration gas, read the instruction manual for the standard gas for correct handling. Special care should be taken when handling hazardous gas such as CO gas and the like to prevent poisoning.
- During maintenance or inspection, be sure to turn ON the ventilation fan in the analyzer to prevent poisoning due to gas leakage.
- When the gas filter of the analyzer is to be replaced or the washing unit needs maintenance, be sure to close the calibration gas valve. Especially, if the calibration gas valve is located at the sample gas inlet, the replacing or washing shall be done after closing the calibration gas valve to prevent poisoning or other trouble.



Caution

- The gas converter is heated to about 220°C. When the catalytic agent needs to be replaced, turn OFF the power for the converter and use heat-proof gloves about 30 minutes later.
 - When the fuse is blown off, check the cause of it and replace it with the same type of fuse having the same capacity to prevent electric shocks or other trouble.
 - When the analyzer is provided with a power leak relay, press the test button to confirm proper operation before making maintenance or inspection to prevent electric shocks.
 - Be sure to lock the door. Do not allow unauthorized persons to use the door key. Do not touch the door carelessly to prevent electric shocks and other trouble.
- ⊙ The following items must be observed to prevent electric shocks or injury and to ensure safety.
- Take off metallic objects such as wrist watch before starting the work.
 - Do not touch the device with wet hands.

10.1 Routine maintenance and inspection

Maintenance/inspection item	Procedure
Monitoring of sample flow rate Monitoring of conditioner bubbling quantity (Note)	Prescribed flow rate: The flow rate is normal when the ball is at 0.4 ℓ /min. and there is slight bubbling at the bottom of conditioner. Adjust the needle valve so that a flow rate of 0.4 ℓ /min. is available. If the prescribed flow rate is unobtainable even with the needle valve fully open though there is slight bubbling, then the capillary (sample line) should be checked for clogging. In case there is no bubbling, the aspirator, conditioner, electronic cooler and pipe should be checked for clogging. And if water decreases in the conditioner because of heavy bubbling, the capillary of bypass line should be checked for clogging.
Conditioner Air aspiration tube level	Good if H2 level shown in Fig. 10-1 is longer than 100mm. If air is aspirated through the air aspiration tube, then the pressure loss at the stage before the conditioner filter has become large. Check the gas extractor filter (see (1) in 10.5) and gas pipes for clogging.

Maintenance/inspection item	Procedure
Contamination of membrane filter	Replace the filter paper if it has blackened (see (3) in 10.5). If contamination occurs rapidly, then check the pre-stage filters of the gas extractor ((1) in 10.5), conditioner filter ((2) in 10.5), etc.
Electronic gas cooler	Check the fan rotation.
Temperature controller for NO ₂ /NO converter	Check that the controlled temperature is approx. 220°C (200°C in case of NO/CO analyzer).

Note) Bubbling will be eliminated when a pressure control valve is equipped.

Prescribed flow rate value should be checked in the piping system diagram separately presented.

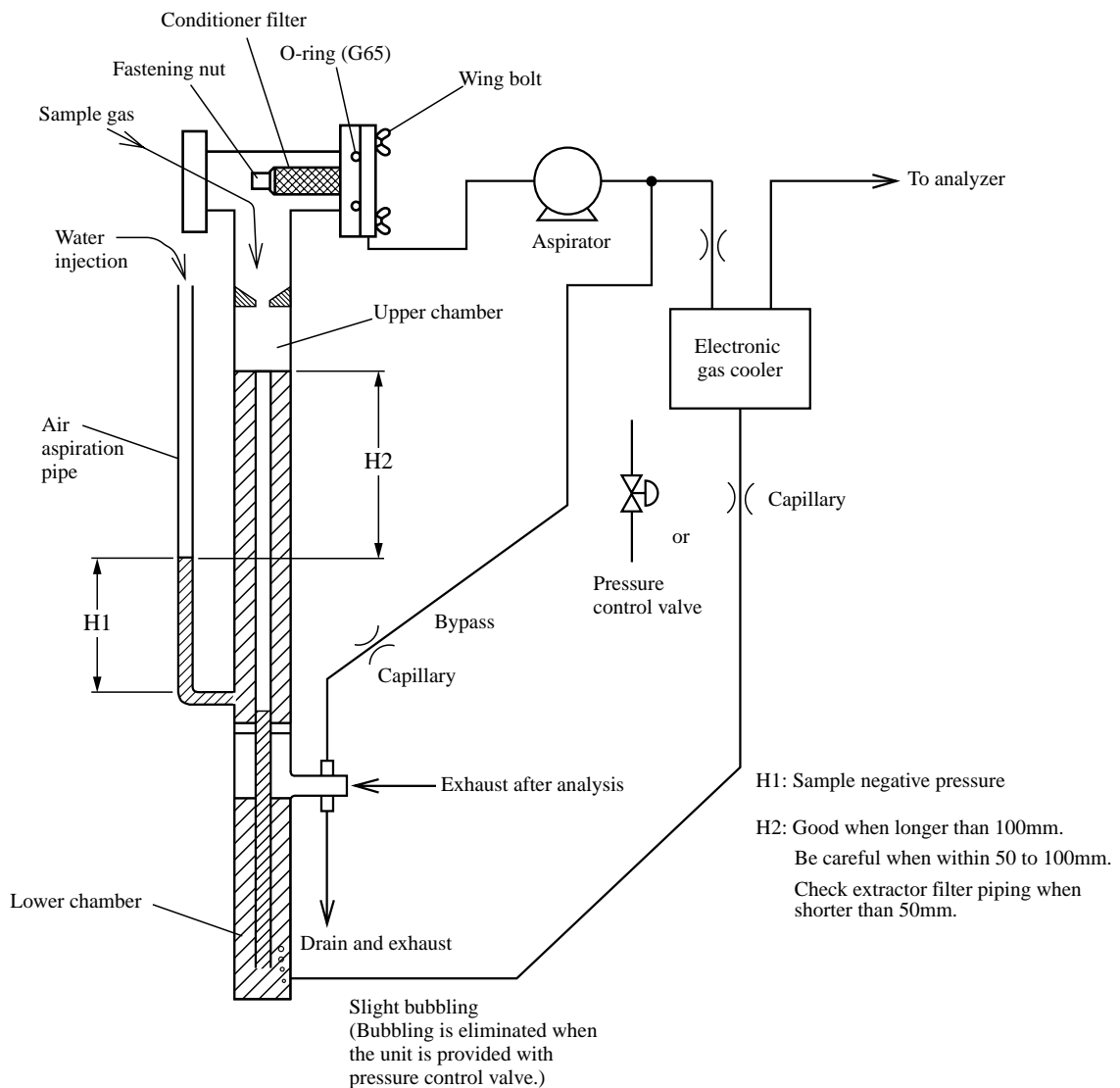

Fig. 10-1 Conditioner

10.2 Periodic maintenance and inspection

Maintenance/inspection item	Referential frequency	Procedure
Analyzer calibration	Weekly	Refer to section 8.5 to 8.6.
Check of standard gas filled pressure		It takes at least 1.5 months to deliver the standard gas. So the gas should be ordered 2 or 3 months in advance.
Water level in upper chamber of conditioner	Monthly	Supply water if level is below overflow port.
Replacement of membrane filter paper	Every two months	Replace with new filter paper (stop the aspirator when exchanging). See 10.5 (3).
Inspection and replacement of conditioner filter, O-ring	Biannually	Replace these parts if flow rate doesn't increase because of adherence of dust. See 10.5 (2).
Capillary		Replace if clogged.
Check of valve and diaphragm of aspirator (pump)		Check and clean diaphragm. Use valve by turning it to 90° rightward (replace valve when it is turned once). See 10.5 (4).
Leak test of pressure regulator		Apply soapy water or the like and check for bubbles. Either retighten or replace packings if necessary.
Replacement of standard gas		NO, SO ₂ , CO/N ₂ of less than 250 ppm. See 10.4.
Replacement of gas extractor filter element, O-rings		O-ring requires replacement. Filter element may be reusable after cleaning. See 10.5 (1).
Catalyst of NO ₂ /NO converter	Yearly	Replacement (when NO ₂ gas concentration is 10 ppm or less) Note: Replace once every 8 months when NO gas concentration is measured in the setting range of 0 to 200ppm or more at 0.5L/min.
Replacement of standard gas		See 10.4.
Aspirator		Replacement of diaphragm
Contamination, leak test of piping		Clean pipes or replace if necessary.
Exchange of water in conditioner		
Overhaul		

10.3 Other maintenance and inspection

(1) Space heater and ventilating fan

If the ambient temperature drops below 5°C during winter or the like, then turn ON the space heater. The ventilating fan should always be left ON.

(2) Blowback of gas extractor (option)

Turn off the aspirator and close the measured gas line before conducting a blowback. Frequent blowback will cause the temperature of the gas sampler to drop and result in corrosion, so it should be kept to a minimum.

10.4 Concentration guarantee term of standard gas cylinder (for NO_x, SO₂, CO and O₂ analyzer)

Kind of gas	Concentration range	Guarantee term
NO/N ₂	0.4ppm or more, and less than 250ppm	6 months
NO/N ₂	250ppm or more, and less than 5%	1 year
SO ₂ /N ₂	0.4ppm or more, and less than 250ppm	6 months
SO ₂ /N ₂	250ppm or more, and less than 1 %	1 year
CO/N ₂	2.4ppm or more, and less than 100ppm	6 months
CO/N ₂	100ppm or more, and less than 15%	1 year
O ₂ /N ₂	0.9% or more, and less than 25%	1 year
N ₂	—	*None
Air	—	*None

* Schedule the use for about one year under proper control.

Note: It is empirically known that standard gas concentration remains within the adequate accuracy for 6 months or 1 year. However, gas maker's guarantee term is as listed in the above table. Therefore, replacement is required within the guarantee term when importance need be placed on traceability.

10.5 Maintenance of sampling device

- (1) Replacement of filter element of gas extractor (extractor type : ZBAK1)
 - (a) Turn off power supply to the extractor
 - (b) Turn off the pump of gas analyzer
 - (c) After making sure the temperature of extractor has dropped adequately, detach the rainproof cover (remove the wing bolt on the flange side).
 - (d) Remove the locking wing bolt and pull out the internal parts while gripping the handle for filter exchange.

Although you may feel slight stiffness in pulling out the handle for filter exchange, it should be pulled out gradually while turning it.

 - (e) Remove the metallic mesh filter from the seal fixture.
 - (f) After mounting a new element, reverse the above procedure.

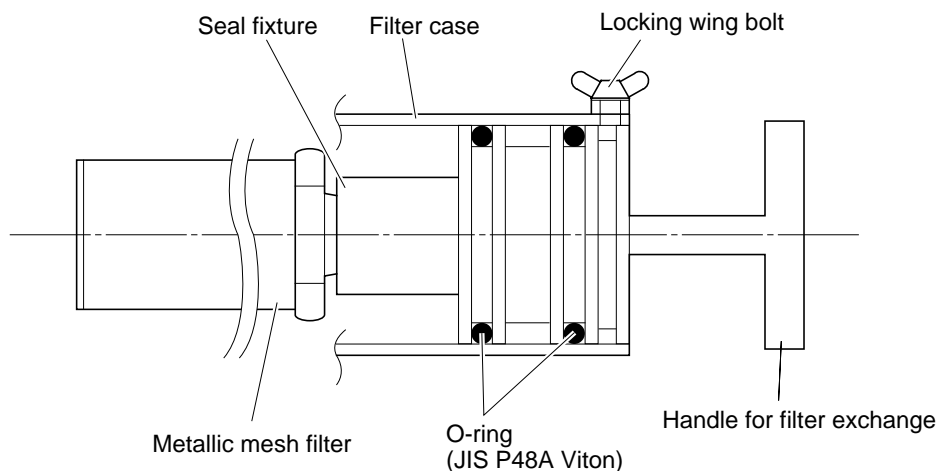

Fig 10-2 Gas extractor (type ZBAK1)

- (2) Replacement of mist filter element (See Fig. 10-1.)
 - (a) Loosen the butterfly bolt, and pull the head up and out of the container.
 - (b) Then loosen the retaining nut and remove the contaminated filter element.
 - (c) Replace with a new conditioner filter and O-ring, and reassemble by reversing the above steps.

- (3) Replacement of membrane filter element
 - (a) Turn off the power to the gas aspirator (pump).
 - (b) Turn the lid of the membrane filter counterclockwise and remove it.
 - (c) After removing the lid, detach the inner O-ring and replace the filter element.
 - (d) Wipe dust out of the case by using a clean cloth. Be careful not to let dust enter the gas outlet side.
 - (e) After replacing the filter, reassemble by reversing the above steps.
 - (f) Attach the fluoro pour filter closely to the filter supporting bracket.
 - (g) Apply vacuum grease about once every 6 months to the O-ring.

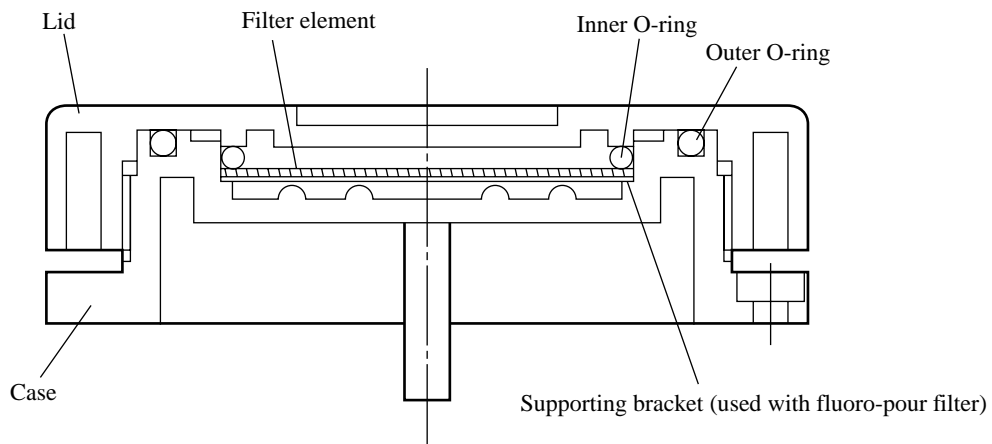

Fig. 10-3 Membrane filter

(4) Replacement of the valve and the diaphragm of diaphragm type aspirator

Replace the seat valve (turn 90° in six months and replace annually) and the diaphragm (replace annually) according to the following procedure.

- (a) Turn off the power supply of the aspirator and remove the inlet and outlet piping connected to the aspirator.
- (b) Remove the four hexagon socket head cap screws. Then cap A and cap B are separated and the valve can be removed.
- (c) Turn the diaphragm counterclockwise with your hand and remove it.
- (d) Place a new diaphragm to the position and mount it by turning it clockwise until it stops.

Note) When mounting, check that the diaphragm is securely engaged in the screw section of the arm slot. Otherwise malfunction may result.

- (e) Place the valve on cap B and turn it 90°. Check that the notches of cap A and cap B are aligned, and then tighten the four hexagon socket head cap screws.

Note) Since complex valve seat is adopted, remove the pin on the underside of the valve from the hole to which the pin has been inserted and reinsert it to the other hole.

- (f) Turn on the power of the aspirator in the interface module. Check that it does not generate abnormal sound. Check also with your hand that the valve is normally operated, that is, air is aspirated from the IN side and discharged from the OUT side. If any abnormality is observed, repeat the procedure from the beginning.
- (g) After checking that the aspirator is normally operated, turn off the power of the aspirator in the interface module, and return the piping to the original position.

Note) Do not apply force abruptly to Rc1/8 screw part when returning the piping to the original position.

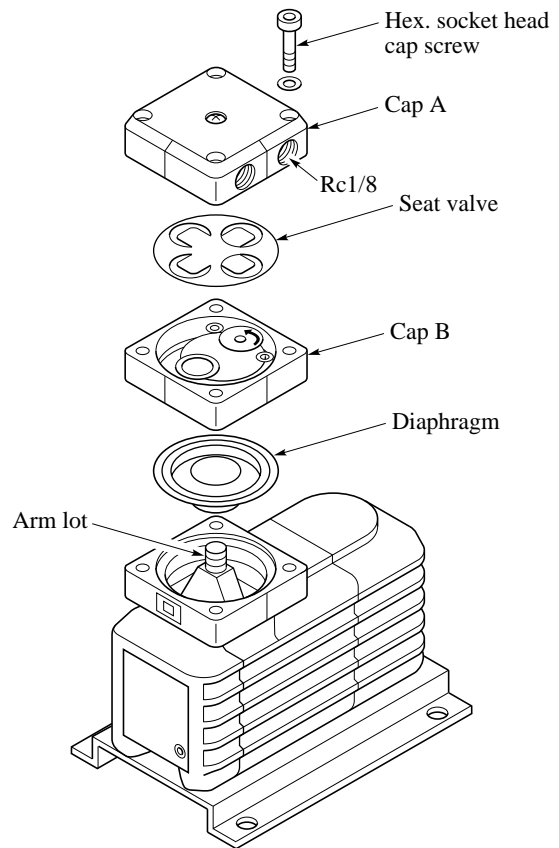

Fig. 10-4 Exploded view of diaphragm type aspirator

(5) Check and maintenance of electronic gas cooler

(a) Fan motor

This motor should be replaced periodically every 20,000 hours (about 2 years in case of continuous operation) as a standard though this varies with operating condition. However, if no abnormality cannot be found at the time of a periodic replacement, the motor is further usable continuously.

(b) Gas passage cleaning procedure

When bubbling has come to diminish significantly, it can be thought that the passage has come to be clogged by dust, etc.

In this case, the gas passage needs be cleaned in the procedure given below.

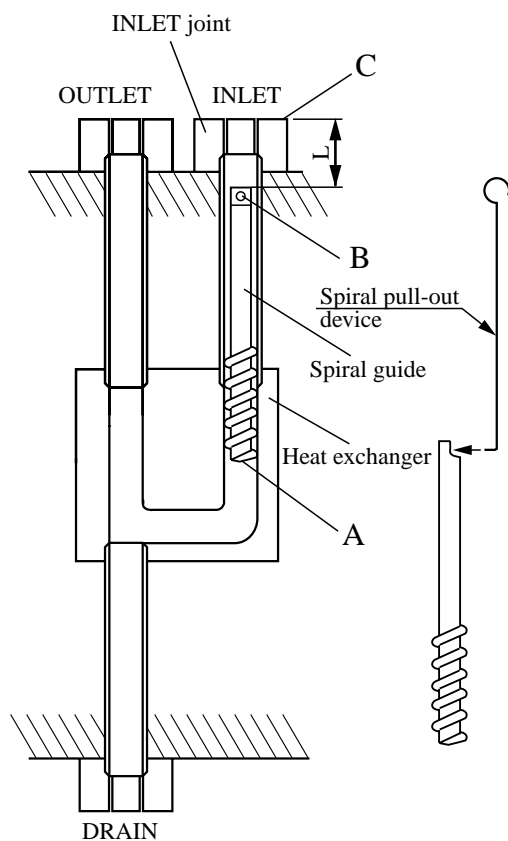

(i) When looking at the inside of INLET joint, area B of the spiral guide can be seen. In the area B, a lateral hole of 1.5mm dia. is bored. So, insert the top of the furnished spiral pull-out device into the hole as shown below and extract the spiral guide.

(ii) Clean the gas passage and spiral guide. For detergent, use a one having a chemical composition which will not affect hard glass, hard PVC, polyethylene and fluoro-rubber. After washing, rinse adequately with water and dry the inside well by blowing compressed air.

(iii) When inserting the spiral guide to the original position, it should be pressed lightly until area A of the spiral guide comes in contact with the bottom. As a standard, area B of the spiral guide should be located with a distance L of about 15 to 20mm from the top face C of INLET joint. Note that attention should be paid since piping is stepped.

Note) For sampling with the pressure control valve, clean the gas passage using the above procedure when the sample flow begins to be extremely reduced.

Fig. 10-5 Structure of electronic dehumidifier

- (6) Replacement of NO₂/NO converter catalyst
- Turn off power supply to the converter.
 - After half an hour, remove ① ② ③, and extract ④ upward and downward, respectively. Pay attention not to suffer a burn. In addition, carefully handle the ceramic pipe for preventing breakage. When removing ④, ③ will fall simultaneously. So prepare a catalyst receiver.
 - Wind glass wool on the tip of ④ and insert it from the bottom together with ①. Inject one pack of new catalyst from the top. Set ② ③ on the top side. (This step is unnecessary when a membrane filter is provided at the later stage.)
 - Connect the pipe, set the temperature controller at 220°C (200°C for NO/CO analyzer), and turn on power supply.

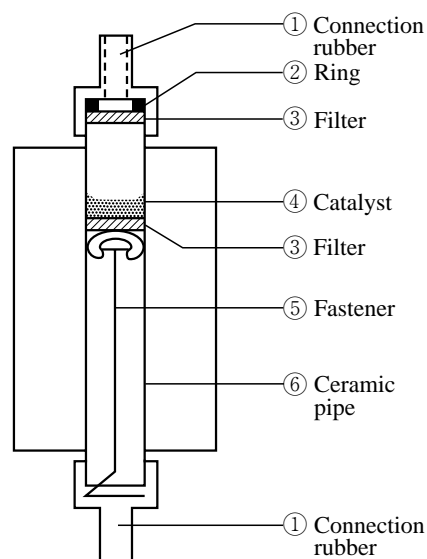

Fig. 10-6 Structure of NO₂/NO converter

- (7) Setting of temperature controller for NO₂/NO converter (PXZ4)
- When pressing the **PV/SV** key, display changes over between PV and SV. (Usually, PV (Process Variable) display is set).
 - Under SV (Set Value) display, set 220°C by pressing the **∇** or **∧** key and determine it by the ENT key. (200°C need be set for NO/CO analyzer.)
 - Parameter need not be set because they have been factory-set.
 - The temperature controller controls converter temperature through the SSR relay.

(8) Setting of pressure control valve

The pressure control valve has been set the discharge about 2 ℓ /min. of sample gas together with drain, when the pressure at the inlet is about 50 kPa. The set pressure increases with a right turn of the setting knob and decreases with a left turn.

Do not turn the setting knob unless the sample flow needs to be changed.

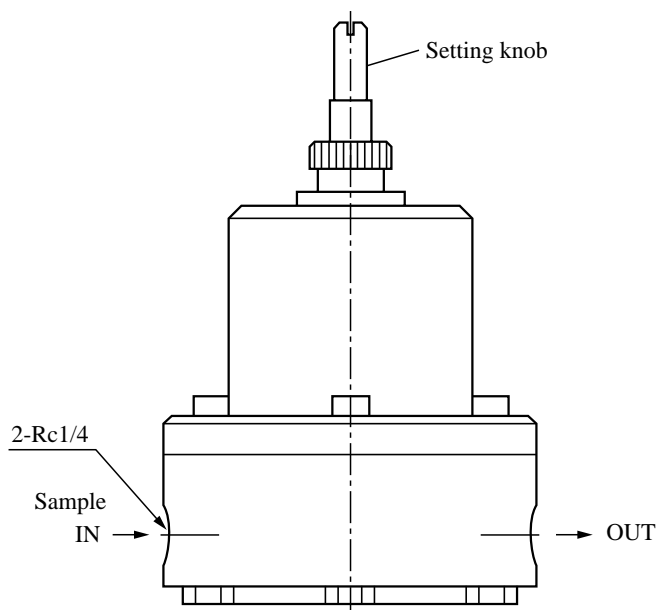

Fig. 10-7 External appearance of pressure control valve

(9) Washing the Permapure dryer

The Permapure dryer is used for SO₂ measurement (2000 ppm or more).

The Permapure dryer has no moving sections nor consumable parts. If precautions in using it are sufficiently respected, it can operate without maintenance usually. However, if its element has clogged, for example, remedy it by the following method.

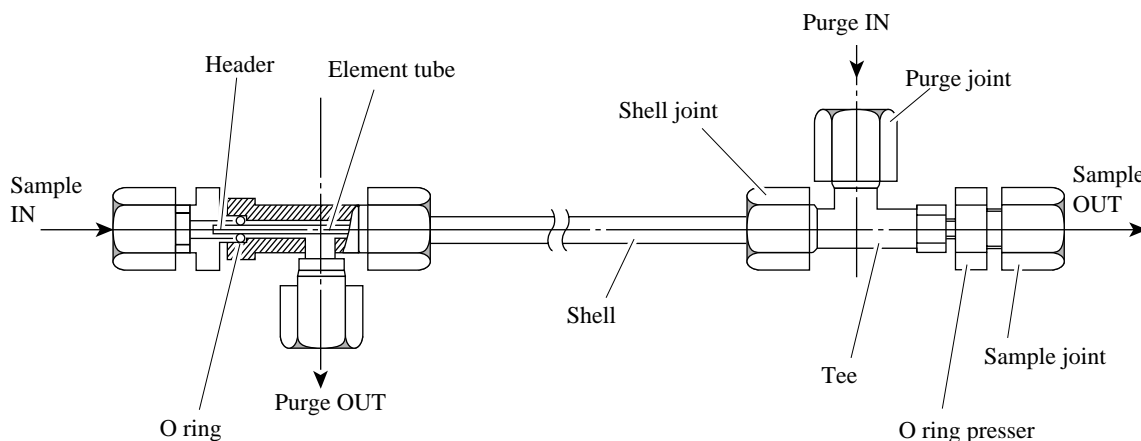

Fig. 10-8 Structure of Permapure dryer

(a) Disassembly

- ① Remove an O ring presser (one side).
- ② Loosen a shell joint (one side).
- ③ Push the header inward and remove the tee.
- ④ Loosen the other shell joint and gently pull out the element.

(b) Washing

- ① Carry out washing with tap water (detergent, alkali solution not allowed).
- ② On a side, remove the sample joint, cap and tee.
- ③ Through the opposite port and purge port, introduce tap water at 127 kPa or lower pressure and 300 to 500 mℓ/min of flow rate.
- ④ Carry out washing for longer or shorter time according to the degree of clogging.
If the clogging is slight, approximately 1 hour of washing is enough.

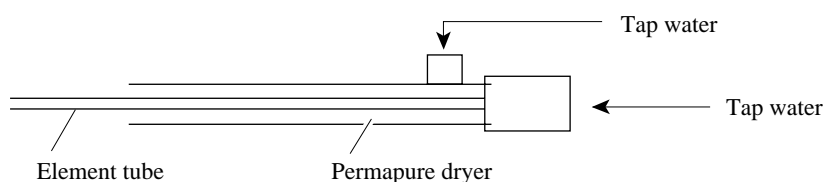
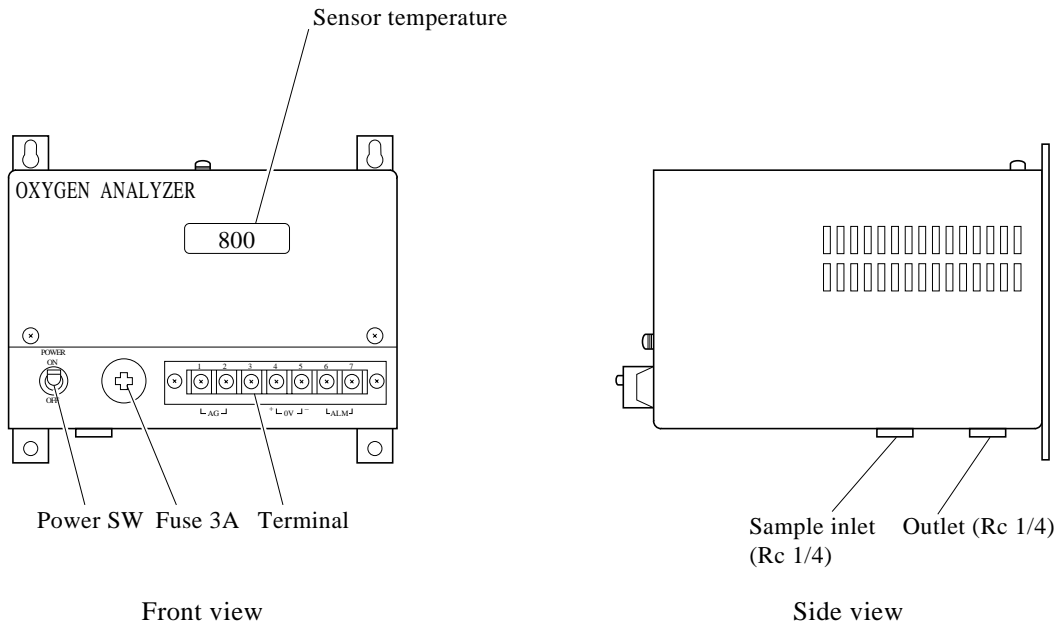

Fig. 10-9 Washing of Permapure dryer

10.6 Maintenance of zirconia O₂ sensor



- (1) Appearance of zirconia O₂ sensor
- (2) Routine maintenance

No parts require periodic maintenance. In case sensor temperature is $800 \pm 5^\circ\text{C}$ or the SO₂ concentration in sample gas is high, you should check occasionally that the outlet pipe is not clogged by the precipitation of crystal. Because the sample outlet is at a high temperature, attention should be paid not to suffer a burn.

10.7 Others, major component figures

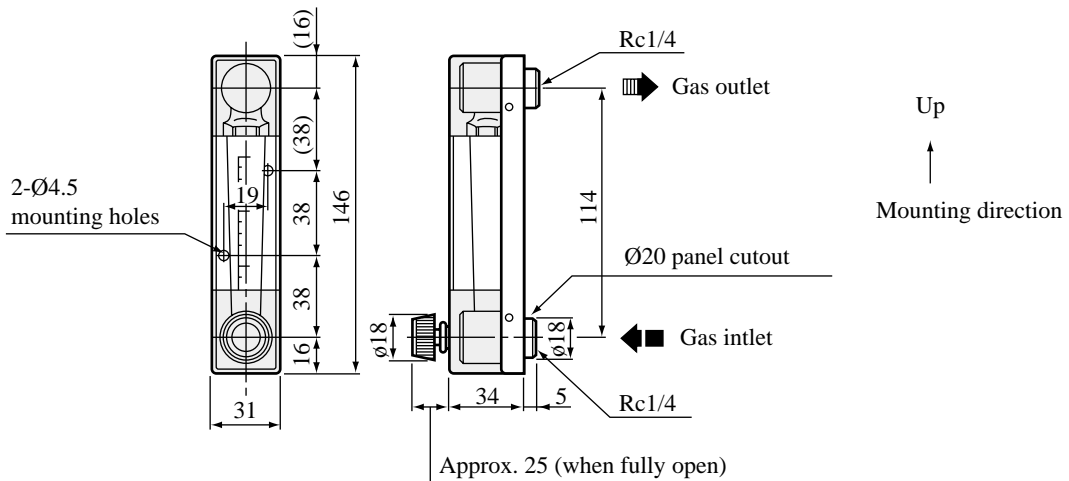

11. STANDARD ACCESSORIES AND SPARES



Caution

- Do not use replacement parts which are not specified by makers. Use of these parts will not only provide the required performance but also result in damage or other trouble.
- Replacement parts used for maintenance must be handled as incombustible objects.

11.1 Standard accessories

No.	Part name	Type of part No.	Quantity (analyzer)				Remarks
			NO _x /SO ₂	NO _x	SO ₂	Other	
1	Membrane filter paper	TK701837C6	—	1 pack	—	1 pack	25 sheets per pack
2	Flouro pour filter for membrane filter	TK741833P3	2	—	2	—	
3	Fuse (for instrument switch)	Various types	2 each	2 each	2 each	2 each	For 2A, 3.2A
4	Cooler puller	—	1	1	1	1	
5	Joint	TK7F7627P1	1 set	1 set	1 set	1 set	Measuring number of gases + 1 For pressure regulator
6	Hose band	TK539474C410	100%	100%	100%	100%	For ø6 tube For pressure regulator
7	Toalon tube 0.3m	TK727528P1	1	1	1	1	For ø6 tube
8	Polyethylene tube 1m	415966P4	1 set	1 set	1 set	1 set	ø6/ø4 For standard gas
9	Anchor bolt	M12 x 160 x 50	4	4	4	4	Option
10	Instruction manual	INZ-TN2ZSP INZ-TN2ZRG	1	1	1	1	
11	Analyzer accessories		1 set	1 set	1 set	1 set	Infrared analyzer fuse 2A x 2pcs. Cell cleaning cloth x 1pc. O ₂ analyzer fuse x 1pc.
12	Wash bottle	TK7H3493P1	1	1	1	1	For conditioner

Note) Part No. 8 will be shipped in connection with the solenoid valve in the locker.

11.2 Spares for 1 year (optional)

No.	Part name	Quantity (analyzer)				Remarks	
		NO _x /SO ₂	NO _x	SO ₂	Other		
1	Spare for converter	Note 2) 1	1	—	—	Catalyst and filter TK726889C3	
2	Conditioner filter	2	2	2	2	TK7H8043P1	
3	Conditioner O-ring	2	2	2	2	G65 chloroprene 8553765	
4	Membrane filter paper	—	1 pack	—	1 pack	25 sheets of TK701837C6 per pack	
5	Fluro pour filter for membrane filter	6	—	6	—	TK741833P3	
6	Membrane filter rubber ring	1	1	1	1	Chloroprene TK733572P1	
7	Membrane filter O-ring	1	1	1	1	G65 chloroprene 8553765	
8	Capillary	1	—	1	—	For 0.5 K (only when with pressure control valve)	
9	Capillary (for bypass)	1	1	1	1	TK729264C6 (ø1mm) (only when without pressure control valve)	
10	Capillary (for cooler out)	1	1	1	1	TK729264C7 (ø1.4mm) (only when without pressure control valve)	
11	Aspirator diaphragm	1	1	1	1	TK725417P5	
12	Aspirator valve	1	1	1	1	TK725417P6	
13	Gas extractor filter element	1	1	1	1	TK7H8439P1	When gas extractor is simultaneously supplied. (ZBAK1)
14	Gas extractor O-ring P48A	2	2	2	2	85504N3	

Note 1) The contents of standard accessories, and spares and supplies for 1 year may vary somewhat according to the specifications.

Note 2) Two parts are required when flow rate is 0.5 ℓ and NO range is beyond 200 ppm.

Code for preparation of 1-year spares and supplies

Analysis gas	Extractor	Code	Remarks
NO _x , SO ₂ , (CO), (O ₂)	With	ZBN4SP12	SO ₂ meter range 200 to 1000ppm
Same as above	Without	ZBN4SP22	SO ₂ meter range 200 to 1000ppm
NO _x , (CO), (O ₂)	With	ZBN4SP32	
Same as above	Without	ZBN4SP42	
SO ₂ , (O ₂)	With	ZBN4SP52	SO ₂ meter range 200 to 1000ppm
Same as above	Without	ZBN4SP62	SO ₂ meter range 200 to 1000ppm
CO, (O ₂)	With	ZBN4SP72	
Same as above	Without	ZBN4SP82	

12. PROCESSING OF HEATING PIPE ENDS

12.1 Outline

(1) Configuration

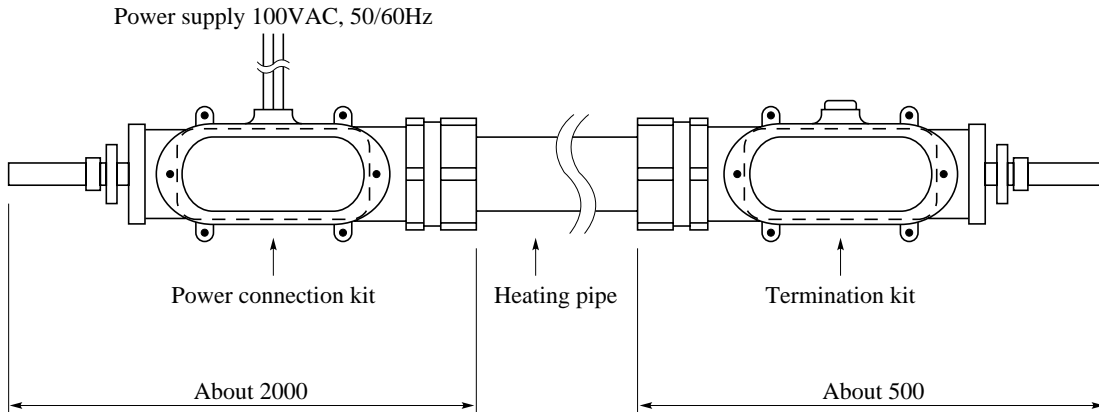

Fig. 12-1

(2) Caution on connection of heating pipe

- ① The clearance between clamp supports must be about 1.2 m in the horizontal direction and about 3 m in the vertical direction.
- ② For a bent piping, bending should be moderate enough to ensure a minimum bending radius of 300 mm or more.

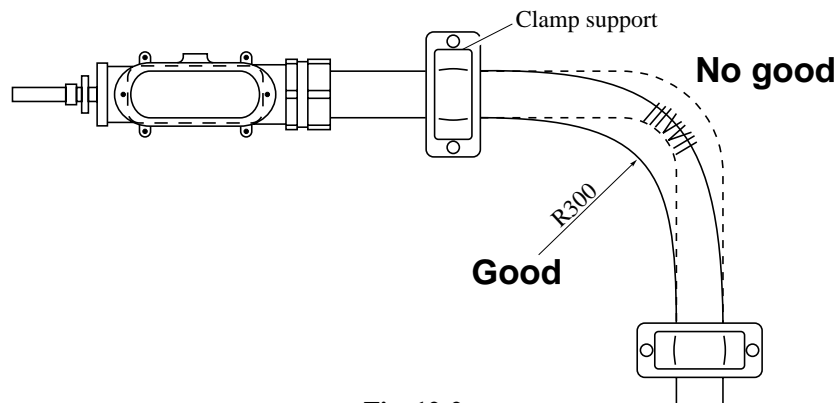

Fig. 12-2

(3) Connection diagram

A heater wire is wound around 2 isolated buses and it is brought into contact with the buses alternately at intervals of 300 mm (heating unit).

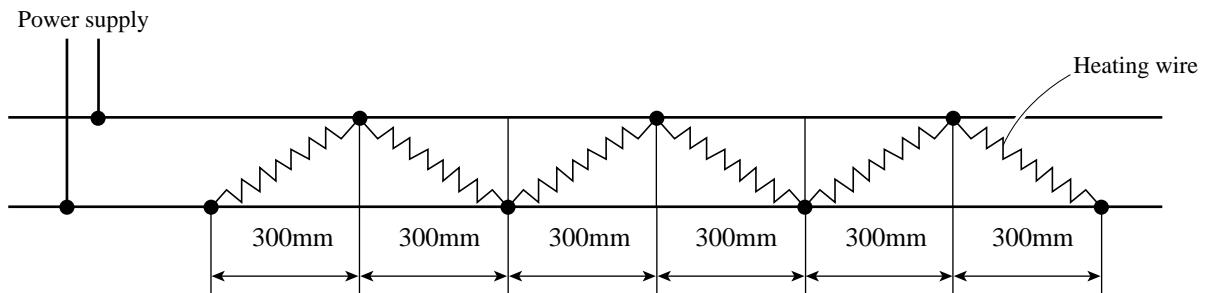

Fig. 12-3

12.2 End processing method

(1) Power supply side (power connection kit)

- ① When cutting out the heating pipe, take care not to damage the heater wire.
- ② Pulling out on the inside of grid section provides a non-heating area of about 300 mm at maximum.

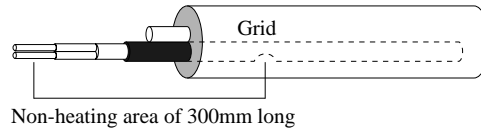

Fig. 12-4

- ③ Peel the outer sheath covering of heater as shown below and cut off the heater wire as close to its root as possible.

(HTP type heater has fiber glass, heater wire and thin Teflon covering under its outer sheath covering. So the outer sheath covering should be peeled neatly.)

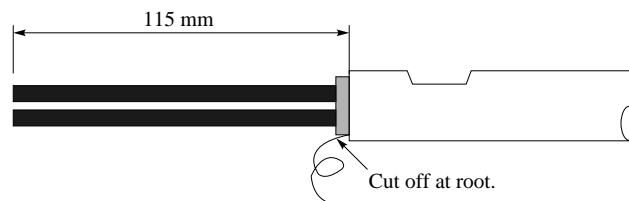

Fig. 12-5

- ④ Apply RTV (silicone sealant) to the terminal boots and plug the boots into the heater. Then wind a sealing tape across the boots and heater.

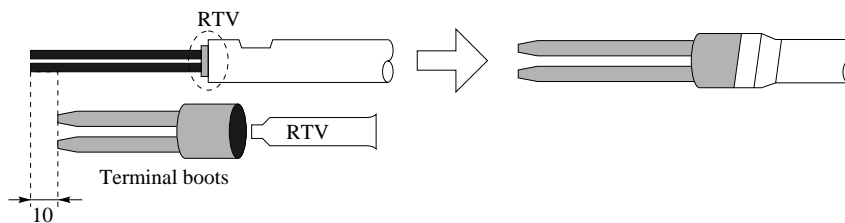

Fig. 12-6

- ⑤ For connection with the power supply wire, use a press-fitting sleeve. If the press-fitting section is loose, contact resistance becomes large to cause abnormal heating of the sleeve.

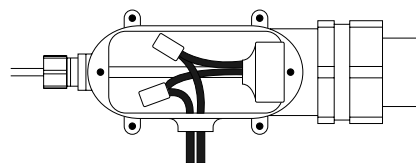
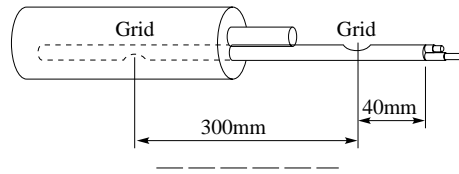

Fig. 12-7

(2) Termination side (termination kit)

① Cut the heater in the dimension shown at right. Push back the metallic braiding and fix it with Teflon tape.



② Peel the outer sheath covering of heater and cut off the heater wire as close to the root as possible. Expose the bus of heater wire toward the cut end starting from a point about 40 mm away from the nearest grid. (HTP type heater has fiber glass, heater wire and thin Teflon covering under its outer sheath covering. So the outer sheath covering should be peeled neatly.)

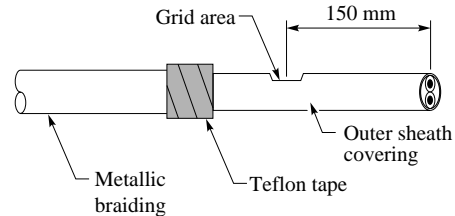

③ Cut off buses at different lengths.

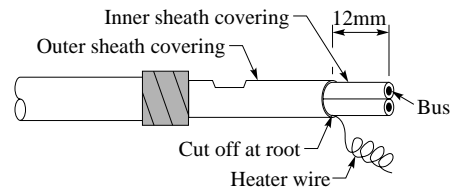

④ Wind Teflon tape while carefully securing isolation between the heater wire and buses.

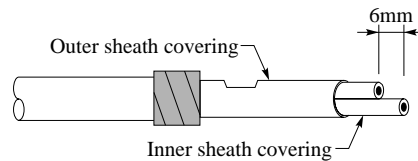

⑤ Apply RTV silicone sealant to the end cap and the Teflon tape-wound section. Then, fit the end cap while bleeding air.

Note) After fitting the cap, move it back slightly.

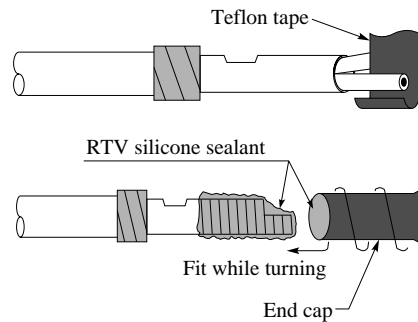

⑥ Fix the end cap by winding seal tape as many times as possible for preventing the cap from slipping off.

Note) Never short-circuit the end (bus) of heater.

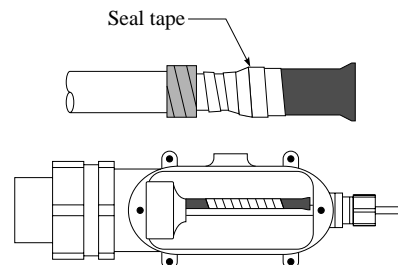

12.3 Check after piping

- ① The heating pipe is not sunk significantly due to a clamp, etc.
- ② The bent section has an adequately large bending radius.
- ③ Electrical connections are exact.
- ④ The end of heater wire (bus) is not short-circuited (it must never be short-circuited).
- ⑤ All parts of the connection kit (sealing connector), etc. have been used.
- ⑥ Screws of the connection kit (sealing connector), etc. have been tightened completely.

12.4 Clamp support

Clamps for conduit should be used. For heating pipe profile of the tube trace, refer to 12.5. The heating pipe should be clamped so that it will be sunk significantly.

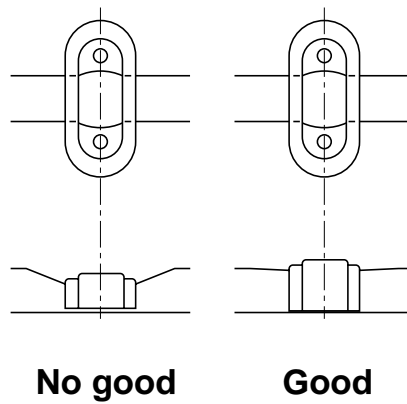
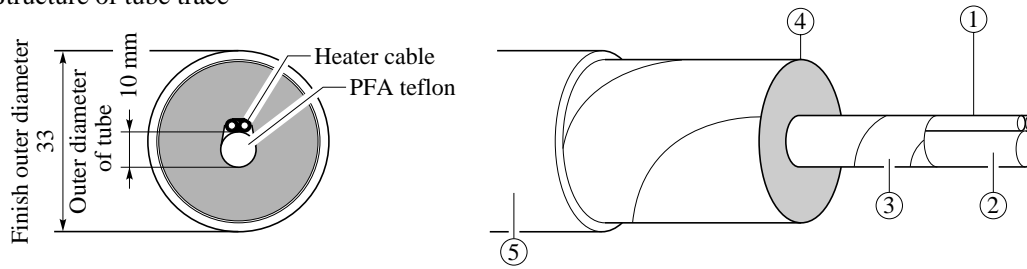

Fig. 12-8

12.5 Specifications of tube trace

(1) Structure of tube trace



- ① Heater cable (power limiting cable)
- ② Process tube
- ③ Aluminum tape
- ④ Fiber glass heat insulator
- ⑤ PVC jacket

Fig. 12-9

(2) Specifications of tube trace

①	Heater cable	HPT 20-1 BN 35.4w/m at 100°C (100V AC)
②	Process tube	10/8 mm ϕ PFA Teflon tube
③	Aluminum tape	50% overlap
④	Fiber glass	Thermal conductivity 0.2kJ/m-h.°C
⑤	PVC jacket	UL 105°C, black PVC

12.6 Specifications of heating pipe

Maker: Thermon Far East

Dealer: Fujikin, Japan

13. TROUBLESHOOTING



Caution

- When trouble cannot be remedied even after following the instruction manual, contact your dealer or Fuji's service station (service engineer). Do not disassemble the device, as it results in electric shocks or injury.

13.1 Troubleshooting of instrument

Trouble	Probable location	Check item	Remedy
Decrease of sample gas flow rate	Filter (primary, secondary, tertiary filters)	Check if filter element is clogged.	Clean or replace element.
	Diaphragm type aspirator	Check if aspirator is working normally.	Clean or replace.
		Check for abnormal sound or vibration.	Retighten screws or replace aspirator.
	Electronic gas cooler	Check if cooler is working normally, check cooling temperature and check for clogging of flow path.	Clean or replace.
	Conditioner	Water decreases in lower chamber.	Inject water and check the capillary (bypass).
	Gas leakage	Check for gas leakage in piping after aspirator or at joints.	Retighten or replace parts.
	Flowmeter	Check for accumulation of drainage or dust in flowmeter. Check adjustment of needle valve.	Clean the flowmeter. Adjust needle valve.
Piping, capillary	Check for bent or clogged piping.	Replace.	
Increase of bubbling flow rate	Bypass flow path	Check for capillary.	Clean or replace.
	Piping	Check for deviated joint.	Connect properly.
Rise of sample gas flow (Note)	Pressure control valve	Pressure control valve is clogged.	Disassemble and clean.
Indicated value is abnormal.	Gas leakage	Check for gas leakage in parts before aspirator such as secondary coarse filter holder, piping, joints, etc.	Retighten or replace parts.
	Diaphragm type aspiration	Check if aspirator is normally operating and sample gas is flowing at set value.	Clean aspirator or replace parts such as diaphragm or valve Adjust sample gas flow.
	Conditioner	Check if water level is normal. Check if air is aspirated.	Supply water. Check primary filter.
	Dissolution of gas	Check for accumulation of drainage in piping.	Clean, and tilt piping so drainage does not accumulate.
	Sampling pipe	Check if SUS pipe is used (for SO ₂ analyzer).	Change to teflon tube.

Note) Pressure control valve is used.

Trouble	Probable location	Check item	Remedy
Indicated value is not as expected.	Gas leakage	Check for gas leakage before the aspirator.	Retighten or replace parts.
	Interference due to moisture	With respect to zero gas indication, the indicated value when air is introduced exceeds $\pm 2\%$ full scale.	Readjust to compensate for moisture interference.
	Measuring range	Check if correct range is set.	Reset the range.
	Zero, span	Check zero and span using standard gas.	Adjust for correct zero point and span.
	Cell window	Check if cloudy	Clean the window.
Indication doesn't change	Power supply, fuse	Check the power supply voltage and fuse.	Replace the fuse.

13.2 Error codes and remedies

This analyzer is provided with self-diagnosis functions, and an error code is displayed if an abnormality occurs in the instrument.

Take a proper measure with reference to the instruction manual of infrared gas analyzer when an error code appears.

14. SPECIFICATIONS

Specifications

Type of cubicle:	Outdoor, self-standing, sealed type or indoor type
Measuring system:	Non-dispersion infrared absorption (NDIR method) for NO _x , SO ₂ , CO and CO ₂ ; zirconia method for O ₂ .
Sampling system:	Dry sampling electronic cooling & dehumidification system (Permapure dryer adopted)
Measuring range:	NO _x — 0 to 100 2000 ppm
(Range selection:	SO ₂ — 0 to 100 1000 ppm
Max. rate 1:20	CO — 0 to 200 2000 ppm
(except for O₂))	CO ₂ — 0 to 5 50%
	O ₂ — 0 to 10/25%
	Note: Measuring range of each gas is 50 to 5000ppm, available in approved type (special order).
Repeatability:	±0.5% of full scale
Drift:	Zero — ±2% of full scale/week for NO _x , SO ₂ and CO ±2% of full scale/month for O ₂
	Span — ±2% of full scale/week
Linearity:	±2% of full scale
Response time:	90% response from the inlet of cubicle SO ₂ : 4 min. CO : 2.5 min NO : 2 min Others : 3 min.
Output:	4 to 20mA DC (allowable load resistance 550Ω), non-isolated. For the number of output points, see Table 1.
Contact output:	Each NO (1a) contact (100V AC, 1A) for error (analyzer error, calibration error) and auto calibration status
Indication:	Digital indication (indicating measured value and measuring range on analyzer front panel of infrared gas analyzer)
Sample gas extracting rate:	Approx. 2 ℓ /min.
Gas extractor:	Electrical heating type (filter built in) Filter mesh — 40μm mesh of 316 stainless steel Probe — 316 stainless steel, length 600, 800 or 1000mm Flange — JIS 5 K65AFF
Sample inlet tube:	∅ 10/ ∅ 8mm teflon tube for CO and O ₂ meter and NO _x and O ₂ meter Heating tube (∅ 10/ ∅ 8mm teflon tube) for NO _x , SO ₂ and O ₂ meter and NO _x , SO ₂ , CO and O ₂ meter
Standard gas (3.4 ℓ):	Standard air gas for zero calibration and O ₂ span calibration Standard analyte/remaining N ₂ gas for low range span calibration and O ₂ zero calibration
Form verification:	Form for all components already approved
Ambient temperature:	-5 to +40°C
Power supply:	100±10V AC, 50 or 60Hz
Power consumption:	Approx. 1,200 VA (excluding consent and heating tube)
Mass (weight):	Approx. 300 kg (excluding standard gas)
Finish color:	Munsell 5Y 7/1 semigloss

Standard requirements

for sample gas:

Temperature	—	60 to 800°C
Dust	—	100 mg/Nm ³ or less
Pressure	—	-2.94 to +2.94kPa
Components	—	SO ₂ 0 to 1000ppm NO _x 0 to 2000ppm (NO ₂ 100ppm or less) CO ₂ several % to over 10% CO 0 to 2000ppm O ₂ 0.5 to 21% H ₂ O 0 to 40% HCl 0 to 100ppm N ₂ remaining percent

When other components are contained in the sample gas, consult with Fuji.

Note) NO₂/NO converter catalyst life:

1 year/NO₂, 10ppm

1 month/NO₂, 100ppm

Installation requirements: Select a location free from direct sunlight and severe vibration.

Table 1 Number of output points and kinds of outputs

Type	ZSP1L	ZSP1F	ZSP1P	ZSP1B	ZSP1A	ZSP1H	ZSP1M
Measuring component	NO _x , SO ₂ , CO, O ₂	NO _x , SO ₂ , O ₂	NO _x , O ₂	CO, O ₂	SO ₂ , (O ₂)	NO _x , CO ₂ , O ₂	NO _x , SO ₂ , CO, CO ₂ , O ₂
No. of output points	11	7	3	3	3	5	12
Kind of output	A, B, C, D (2 points), E, F, G, H, J, K	A, B, D, E, F, H, J	A, D, E	C, D, K	B, (D)	A, B, D, E, K	A, B, C, D (2 points), E, F, G, H, J, K, L

A: NO_x instantaneous value

C: CO instantaneous value

E: NO_x instantaneous value after O₂ correction

G: CO instantaneous value after O₂ correction

J: 1hr. moving average SO₂ value after O₂ correction

L: O₂ instantaneous value

B: SO₂ instantaneous value

D: O₂ instantaneous value

F: SO₂ instantaneous value after O₂ correction

H: 1hr. moving average NO_x value after O₂ correction

K: 4hr. moving average CO value after O₂ correction

(1) **NO_x after O₂ correction**

CO after O₂ correction

(a) **Calculating equation**

$$C = \frac{21 - O_n}{21 - O_s} \cdot C_s$$

C: Concentration after O₂ conversion

C_s: NO_x or CO concentration measured

O_s: O₂ concentration measured

O_n: O₂ concentration as conversion basic:

4% Oil combustion boiler

5% Gas combustion boiler

6% Solid object combustion boiler, petroleum heating furnace

12% Garbage incinerator

(b) **Block diagram**

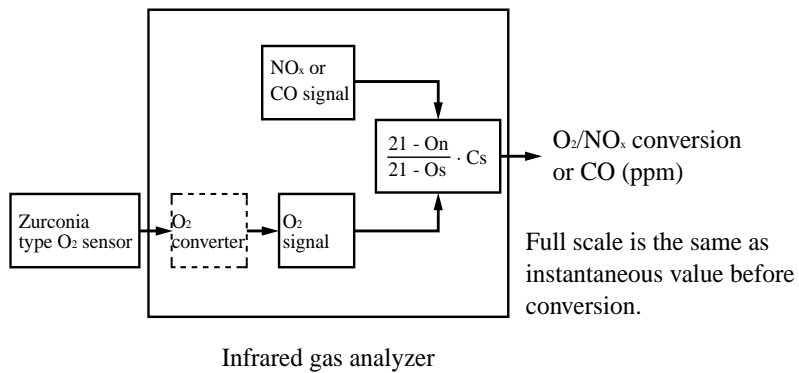

(2) **Moving average output**

1 hr. moving average output (for NO_x, SO₂)

4 hr. moving average output (for CO)

Automatic calibration

- **Calibration tolerance:** $\pm 0.2\%$ FS
- **Automatic calibration output hold:** Possible
(Example in 4 component analyzer):

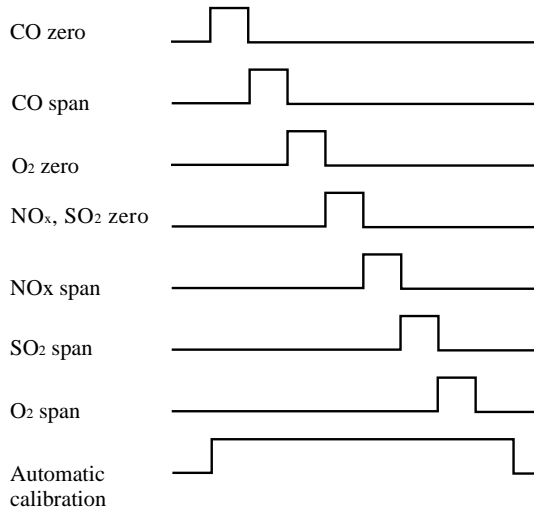

- **Calibration cycle:** Once/day (variable, up to 7 days)
- **Calibration gas feed time:** 2 to 10 min. (variable), common to each gas
- **Display:** Calibration failure
Error code (E-) is displayed when one-time calibration volume is more than $\pm 20\%$ FS on both zero and span and it is under calibration:
CAL lamp ON

Ordering information

1. Measuring range of analyzer
2. Length of sampling pipe
3. Insertion length of sampling tube
4. Power voltage/frequency
5. Instruction required when standard gas is not necessary
6. Instruction required when individual inspection is not necessary
7. Necessity of spares and supplies (for 1 year)
8. Additional functions

Note: When special functions such as remote range selection, output hold by external contact, automatic calibration, automatic calibration start by external contact, insulation output, measured value concentration alarm, etc. are required, they should be separately designated.

CODE SYMBOLS

1	2	3	4	5	6	7	8	9	10	11	12	Description	
Z	S	P					4	-					
			1									Application Combustion exhaust gas (standard condition)	
			2									Other exhaust gas	
		P										Component NO _x + (O ₂)	
		A										CO + (O ₂)	
		B										SO ₂ + (O ₂)	
		F										NO _x + SO ₂ + (O ₂)	
		H										NO _x + SO ₂ + CO + (O ₂)	
		L										NO _x + SO ₂ + CO + (O ₂)	
		Z										Others	
			0									Oxygen analyzer Without	
			1									With ZFK	
			3									With ZKG (Non-standard)	
				1								Auto calibration With	
								1				Type of cubicle Indoor installation type	
								2				Outdoor installation type	
									1			External piping Heating pipe	
									2			ø10 Teflon tube	
										1		Standard gas 3.4 l	
										2		10 l	
										3		3.4 l + instrument air	
										4		10 l + instrument air	
										5		3.4 l + atmospheric air	
										6		10 l + atmospheric air	
											5	Power supply 100V AC/50Hz	
											6	100V AC/60Hz	
											9	Others 50Hz	
											0	Others 60Hz	

SAMPLING SYSTEM BLOCK DIAGLAM

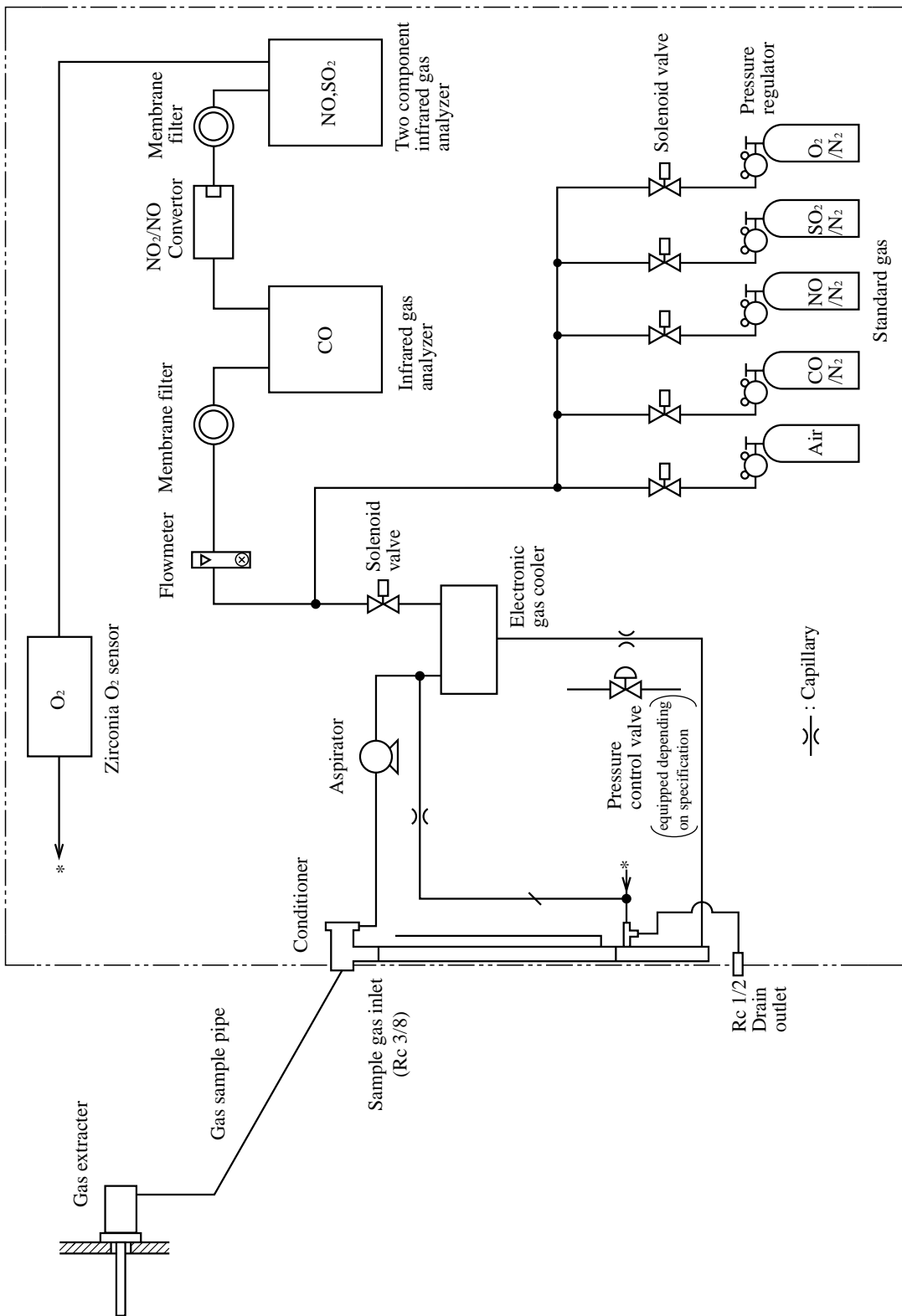

Functions of individual components

- **Gas extractor (type; ZBA):**

With heating type stainless steel filter; standard diameter 40µm for filter.

- **Gas conditioner (type; ZBH9)**

For separating drain and removing sulfuric acid mist and oil mist or fine dust particles. Besides, for preventing aspiration of drain at clogging of extractor filter or sampling pipe, and activating composite operation of constant-pressure bubbler for maintaining a constant sample supply to analyzer.

- **Aspirator (type; ZBG8)**

For aspirating sample gas (sample gas flow rate: about 2 ℓ /min.)

- **Electronic gas cooler (type; ZBC)**

An electronic dehumidifier which dries the moisture in sample gas to a dew point of approximately 2°C.

- **Converter (type; ZDL):**

Added to the NO_x analyzer. A converter using a special catalyst which converts NO₂ gas into NO. The catalyst must be renewed annually (built in the temperature regulator).

- **Solenoid valve (type; AB21)**

Used for the introduction of calibration gas.

- **Memberane filter (type; ZBBM)**

Eliminates fine dust particles with glass-fiber or flouropore filter, and permits monitoring dust adhering condition on the front of the body.

- **Flow meter (type; ZBD)**

Ajusts and monitors standard flow rate of sample gas.

- **Standard gas (type; ZBM):**

Reference gas used for calibrating zero and span of the analyzer. When using a zirconia oxygen meter, this is used together with air for calibrating zero for NO, SO₂, and CO and for calibrating span for O₂.

- **Zirconia O₂ sensor (type; ZFK3, 4)**

Used in combination with the infrared analyzer. Outputs about 0V at measurement of the air, and an inverse logarithm of about 1V at measurement of 0.05% O₂.

- **Pressure control valve (type; ZBD35)**

Sample gas pressure is controlled to 49kPa to maintain a constant flow rate.

OUTLINE DIAGRAM (Unit:mm)

For outdoor installation type

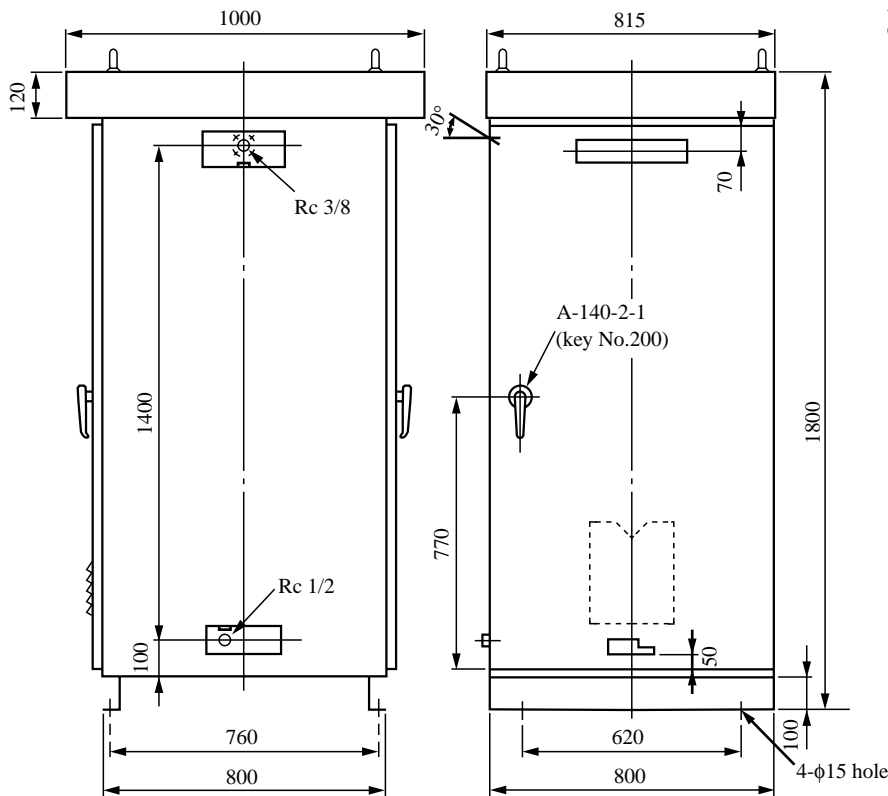

Anchor plan and door opening diagram

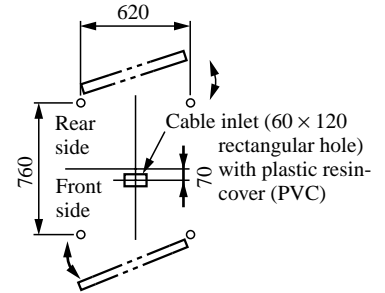

Anchor bolt (option)

(4 - M12 × 160 × 50)

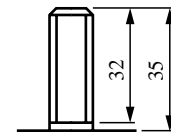

For indoor installation type

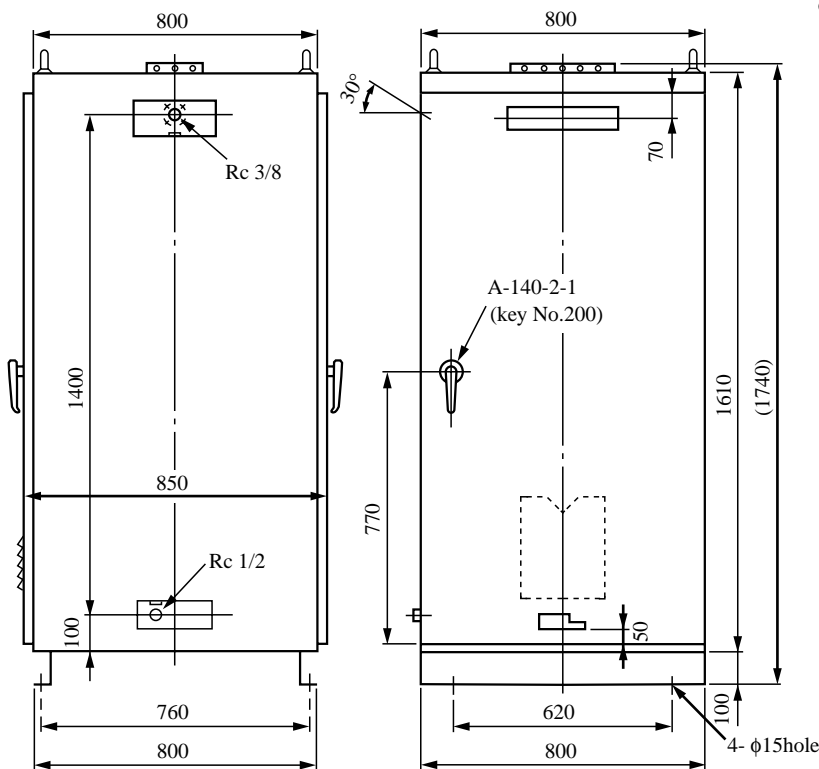

Anchor plan and door opening diagram

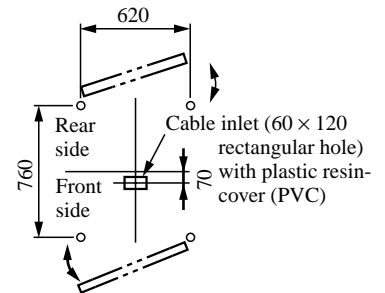

Anchor bolt (option)

(4 - M12 × 160 × 50)

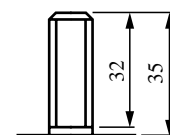

CONNECTION DIAGRAM

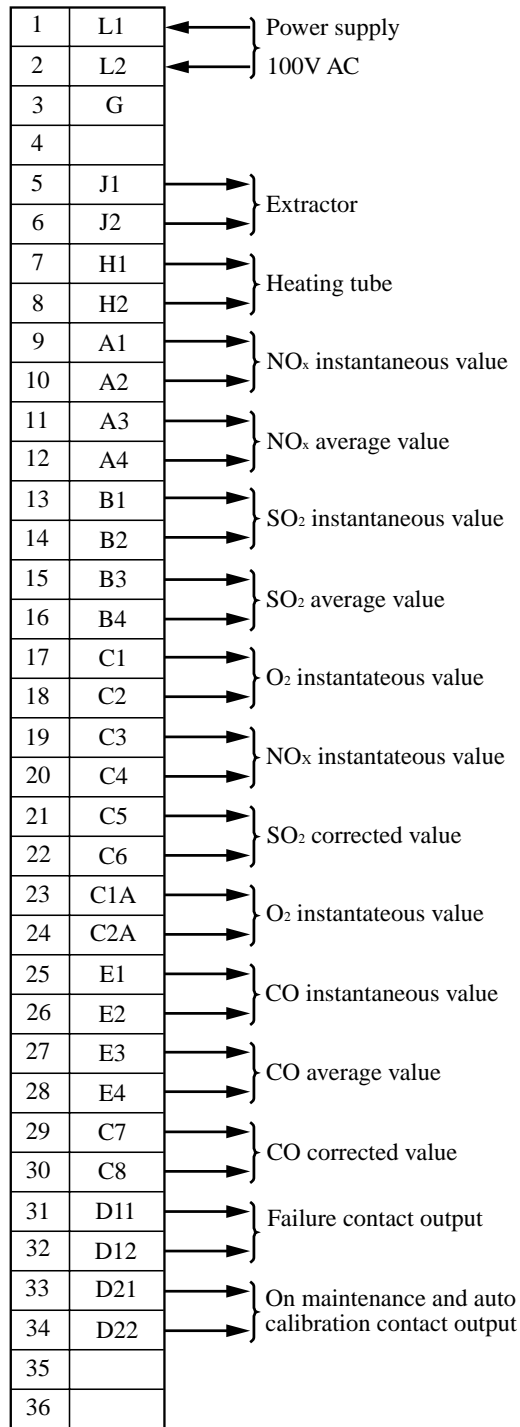

**Note: Terminal numbers are fixed.
(only specified outputs are wired).**

Fuji Electric Systems Co., Ltd.

Head Office

Gate City Ohsaki, East Tower, 11-2, Osaki 1-chome,
Shinagawa-ku, Tokyo 141-0032, Japan
<http://www.fesys.co.jp/eng>

Instrumentation Div.

International Sales Dept.

No.1, Fuji-machi, Hino-city, Tokyo 191-8502, Japan
Phone: 81-42-585-6201, 6202 Fax: 81-42-585-6187
<http://www.fic-net.jp/eng>

Free Manuals Download Website

<http://myh66.com>

<http://usermanuals.us>

<http://www.somanuals.com>

<http://www.4manuals.cc>

<http://www.manual-lib.com>

<http://www.404manual.com>

<http://www.luxmanual.com>

<http://aubethermostatmanual.com>

Golf course search by state

<http://golfingnear.com>

Email search by domain

<http://emailbydomain.com>

Auto manuals search

<http://auto.somanuals.com>

TV manuals search

<http://tv.somanuals.com>