

**DSU-FR EMULATOR
LQFP-64P HEADER TYPE 2
MB2198-304
OPERATION MANUAL**

PREFACE

Thank you for purchasing the LQFP-64P*¹ header type 2 (MB2198-304) for the DSU-FR emulator. This product is used together with the BGA-660P adapter for the DSU-FR emulator (MB2198-300)*² to connect the DSU-FR emulator (MB2198-01)*³ and DSU-FR cable (MB2198-10)*⁴ to a user system that uses a MB91460 series Fujitsu FR*⁴ microcontroller (LQFP-64P)*⁵.

This manual describes how to use the LQFP-64P header type 2 for the DSU-FR emulator. Please read the manual carefully before using. Please contact your Fujitsu sales or support representative for details on which production and evaluation MCU models can be used with this product.

*1 : The lead pitch of package (FPT-64P-M23) is 0.65mm and the body size is 14mm × 14mm.

*2 : Referred to as the “adapter”

*3 : Referred to as the “emulator”

*4 : Referred to as the “DSU cable”

*5 : FR is an abbreviation of FUJITSU RISC CONTROLLER and is a product of Fujitsu Limited.

■ Handling and usage

The handling and use of this product and notes regarding safety use are included in the hardware manual of the DSU-FR family emulator.

Follow the instructions in for the use of this product.

- DSU-FR EMULATOR MB2198-01 HARDWARE MANUAL
- DSU-FR EMULATOR DSU-FR CABLE MB2198-10 OPERATION MANUAL
- DSU-FR EMULATOR BGA-660P ADAPTER MB2198-300 OPERATION MANUAL

■ Caution of the products described in this manual

The following precautions apply to the product described in this manual.



The wrong use of a device will give an injury and may cause malfunction on customers system.

Cuts	This product has parts with sharp points that are exposed. Do not touch edge of the product with your bare hands. There is a possibility that it may be injured.
Damage	When connect the header board to the user system, correctly position the index mark (▲) on the NQPACK mounted on the user system with the index mark (▲) on the header board, otherwise the emulator system and user system might be damaged.
Damage	When mounting a mass production MCU, correctly position pin 1, otherwise the mass production MCU and user system might be damaged.

- The contents of this document are subject to change without notice.
Customers are advised to consult with FUJITSU sales representatives before ordering.
- The information, such as descriptions of function and application circuit examples, in this document are presented solely for the purpose of reference to show examples of operations and uses of FUJITSU semiconductor device; FUJITSU does not warrant proper operation of the device with respect to use based on such information. When you develop equipment incorporating the device based on such information, you must assume any responsibility arising out of such use of the information. FUJITSU assumes no liability for any damages whatsoever arising out of the use of the information.
- Any information in this document, including descriptions of function and schematic diagrams, shall not be construed as license of the use or exercise of any intellectual property right, such as patent right or copyright, or any other right of FUJITSU or any third party or does FUJITSU warrant non-infringement of any third-party's intellectual property right or other right by using such information. FUJITSU assumes no liability for any infringement of the intellectual property rights or other rights of third parties which would result from the use of information contained herein.
- The products described in this document are designed, developed and manufactured as contemplated for general use, including without limitation, ordinary industrial use, general office use, personal use, and household use, but are not designed, developed and manufactured as contemplated (1) for use accompanying fatal risks or dangers that, unless extremely high safety is secured, could have a serious effect to the public, and could lead directly to death, personal injury, severe physical damage or other loss (i.e., nuclear reaction control in nuclear facility, aircraft flight control, air traffic control, mass transport control, medical life support system, missile launch control in weapon system), or (2) for use requiring extremely high reliability (i.e., submersible repeater and artificial satellite).
Please note that FUJITSU will not be liable against you and/or any third party for any claims or damages arising in connection with above-mentioned uses of the products.
- Any semiconductor devices have an inherent chance of failure. You must protect against injury, damage or loss from such failures by incorporating safety design measures into your facility and equipment such as redundancy, fire protection, and prevention of over-current levels and other abnormal operating conditions.
- If any products described in this document represent goods or technologies subject to certain restrictions on export under the Foreign Exchange and Foreign Trade Law of Japan, the prior authorization by Japanese government will be required for export of those products from Japan.

Copyright ©2007 FUJITSU LIMITED All rights reserved

1. Checking the Delivered Product

Before using the MB2198-304, confirm that the following components are included in the box:

• LQFP-64P header board* ¹	: 1
• Screws for securing the header board (M2 × 10mm, 0.4mm pitch)	: 4
• Washers	: 4
• NQPACK064SB* ²	: 1
• HQPACK064SB140* ³	: 1
• Operation manual (Japanese version)	: 1
• Operation manual (English version, this manual)	: 1

*1 : The YQPACK064SB is mounted on the header board (Tokyo Eletech Corporation, referred to as the “YQPACK”).

*2 : The IC socket (manufactured by Tokyo Eletech Corporation, referred to as “NQPACK”). This socket is supplied with a special screwdriver and 2 guide pins. Additionally, the relatively high reliability NQPACK064SB-SL (Tokyo Eletech Corporation, sold separately) can be used by preparing screw holes on the user system board for mounting the socket. For more information, contact Tokyo Eletech Corporation.

*3 : The IC socket cover (manufactured by Tokyo Eletech Corporation, and referred to as “HQPACK”). This cover includes 4 screws for securing HQPACK (M2 × 6mm, 0.4mm pitch).

This product is used as an emulator system by combining with an optional emulator, DSU cable and adapter.

Consult a sales or support representative from Fujitsu Limited for details on the adapter and emulator for this product.

2. Handling Precautions

■ Handling precautions

The header board is precision-manufactured to improve dimensional accuracy and to ensure reliable contact. The header is therefore sensitive to mechanical shock. To ensure correct use of the header in the proper environment, observe the following points regarding its insertion and removal:

- To avoid placing stress on the NQPACK mounted on the user system during connecting the header board.

■ Precautions when operating on the sub clock

When using this product, the evaluation MCU cannot be supplied with a sub clock from the user system.

When the evaluation MCU is operating using the sub clock, use the sub clock on the adapter.

Refer to the operation manual for the adapter for more details.

3. Notes on Designing

■ Notes on designing the printed circuit board for the user system

If the header board is connected to a user system, the heights of parts mounted around the header board are restricted.

When designing the printed circuit board of the user system, consider the heights of components within the range of the header board, as shown in Figure 1, so that the components mounted on the user system do not interfere with the header board.

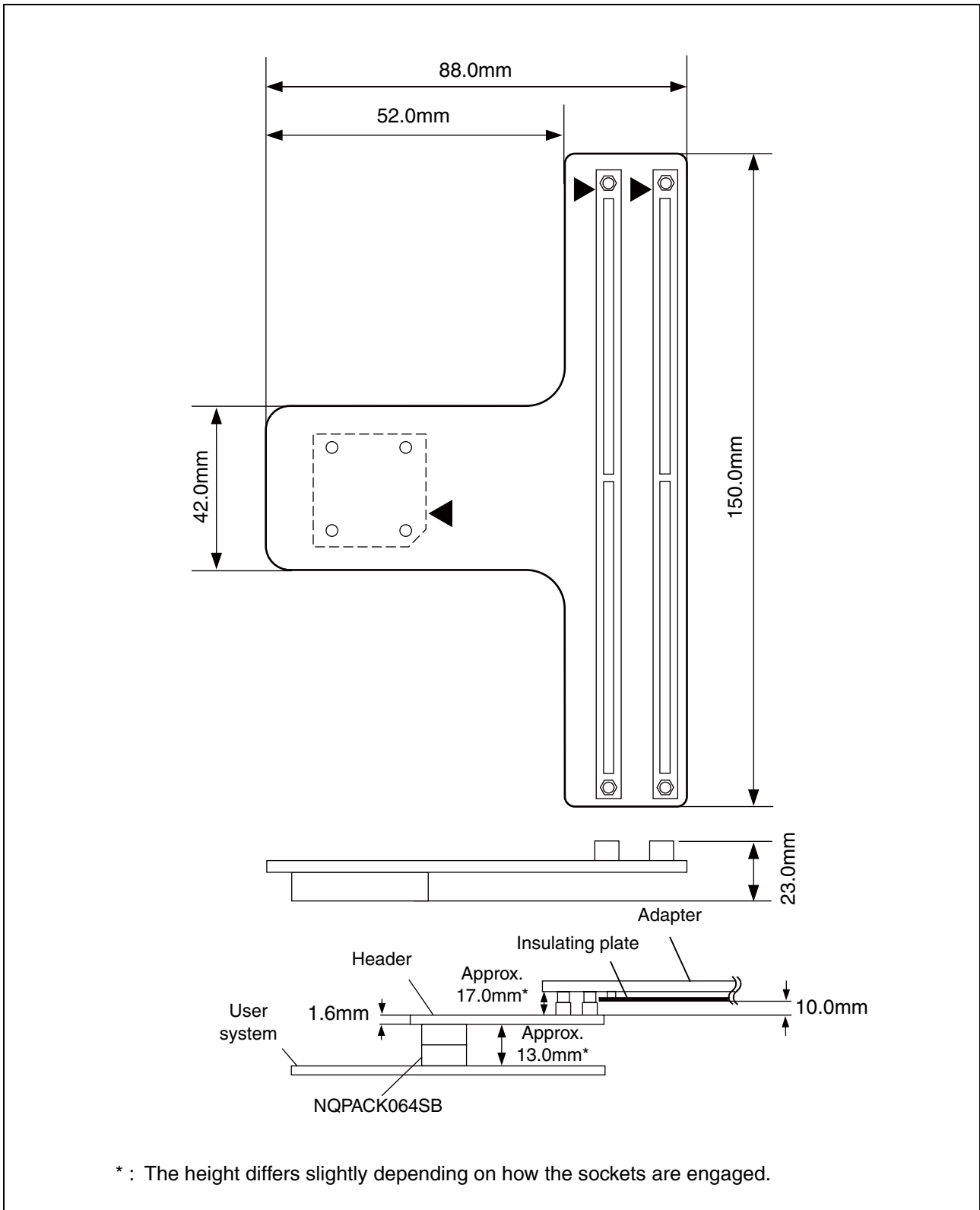

■ MCU footprint design notes

Figure 2 shows the recommended dimensions of the NQPACK footprint mounted on the printed circuit board of the user system.

The printed circuit board of the user system must be designed with due consideration given to this footprint as well as to the mass production MCU.

For more information, contact the Tokyo Eletech Corporation.

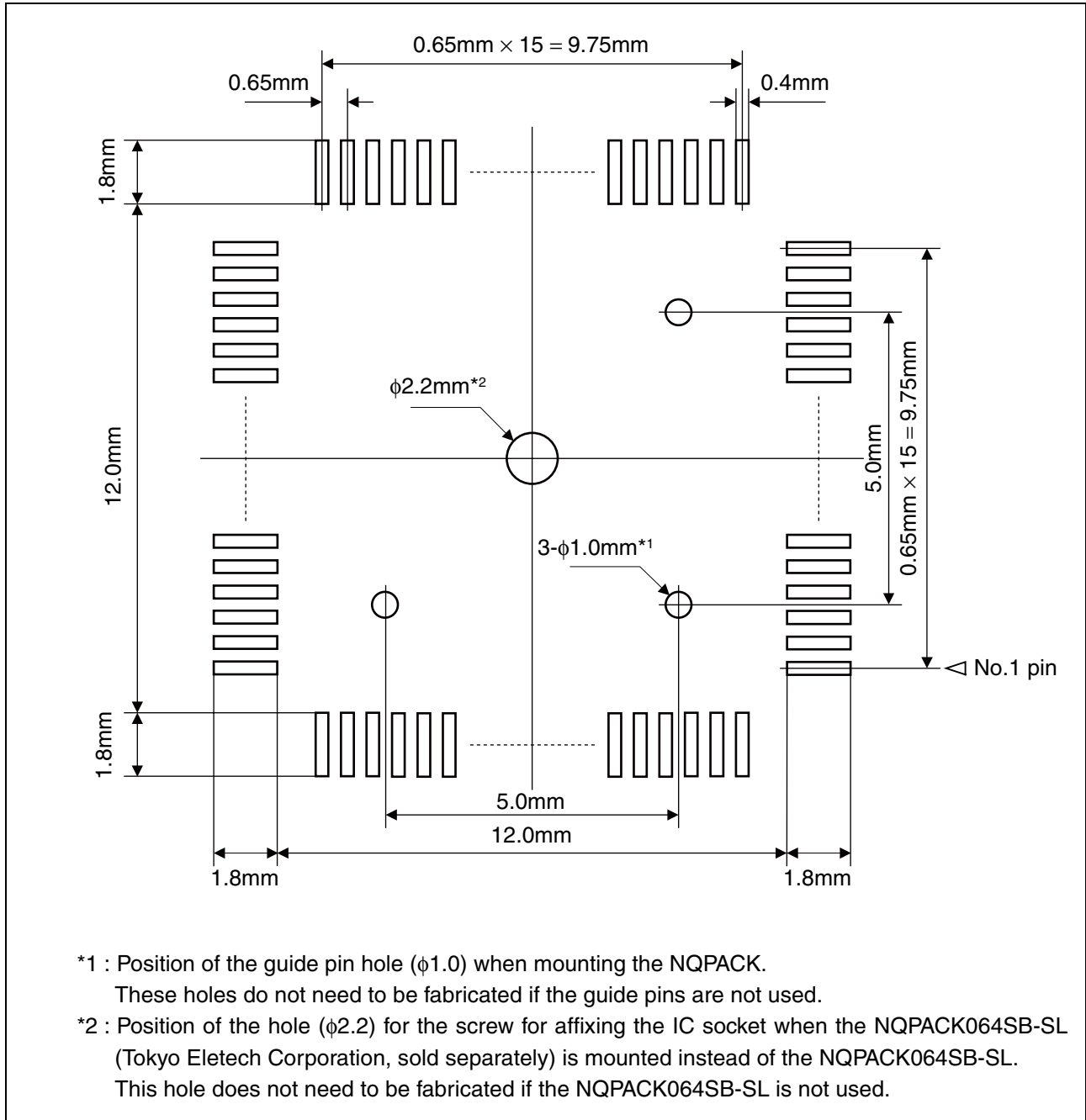

Figure 2 Recommended dimensions of the footprint for mounting the NQPACK

4. Procedure for Connecting to the User System

Before using the MB2198-304, mount the supplied NQPACK on the user system. Connect the header board directly to the adapter. Refer to the operation manual of the adapter for details on how to connect the adapter.

■ Connecting

1. To connect the header board to the user system, align pin 1 indicated by the index mark (▲) on the NQPACK mounted on the user system with the index mark (▲) on the header board and then insert it (See Figure 3).

The YQPACK pins are thin and easy to bend. Check that the YQPACK pins are not bent before inserting it into the NQPACK.

2. Insert each of the screws for securing the header board through a washer and into each of the four holes in the header board. Partially tighten one of the screws with the special screwdriver supplied with the NQPACK and then partially tighten the screw in the diagonally opposite corner. Partially tighten the two remaining screws. Finally repeat the process making the screws equally tight. (See Figure 4).

Take care not to overtighten the screws as this may cause a faulty connection.

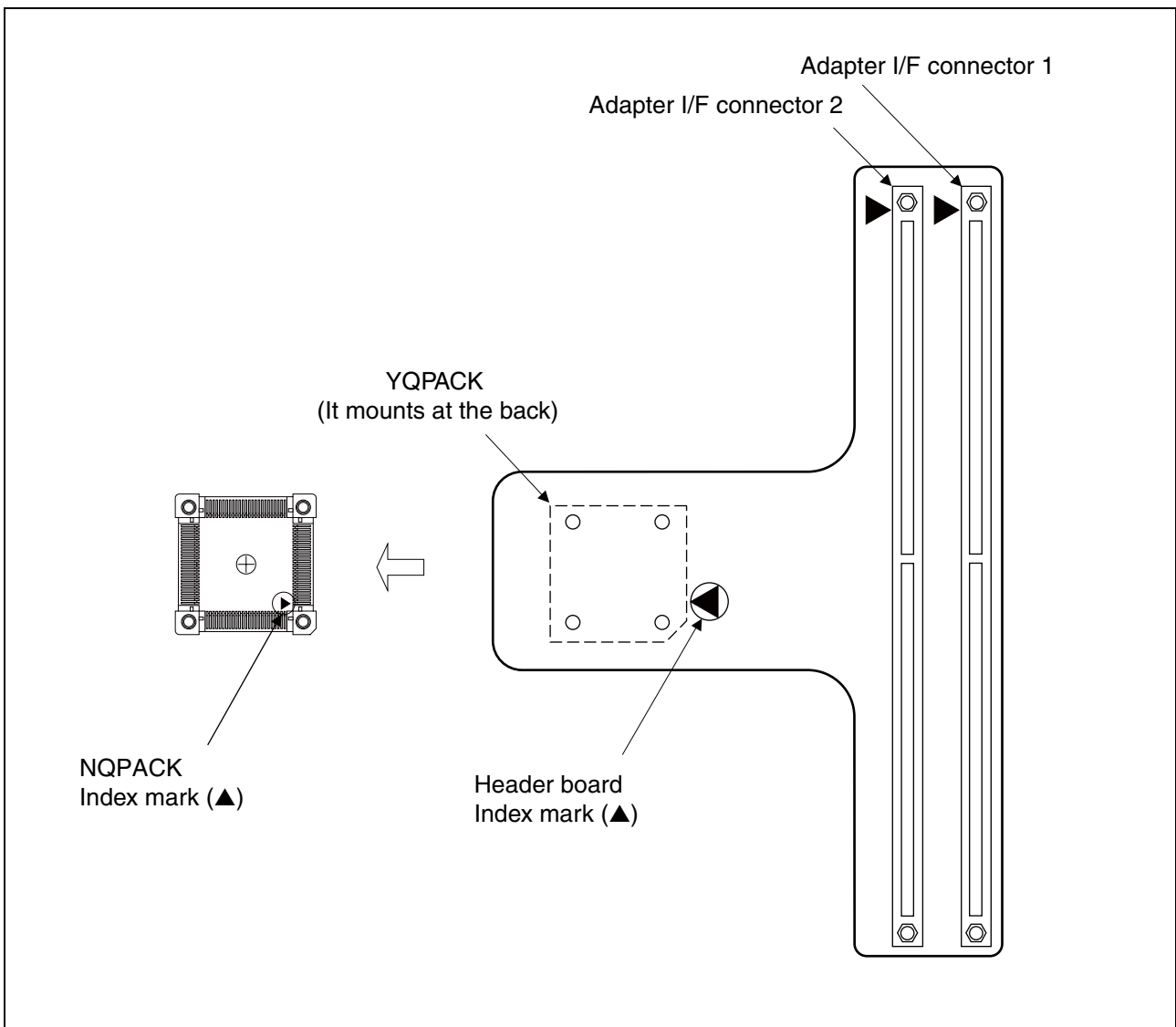

Figure 3 Index position

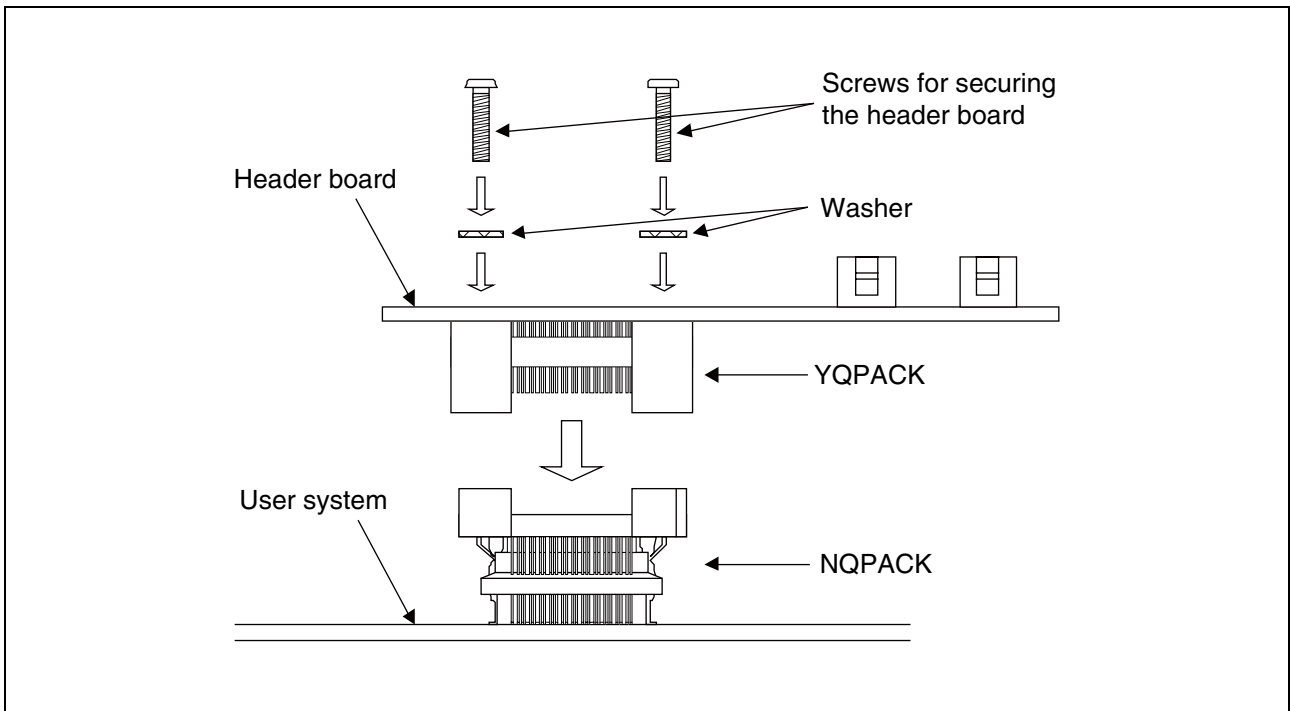

Figure 4 Header board connection

■ **Disconnection**

To disconnect the header board from the user system, remove all four screws, and then pull the header board straight out of the NQPACK.

5. Mounting Mass Production MCUs

Use the supplied HQPACK to mount a mass production MCU on the user system.

■ Mounting

1. To mount a mass production MCU on the user system, align the index mark (▲) on the NQPACK mounted on the user system with the index mark (●) on the mass production MCU.
2. Confirm that the mass production MCU is correctly mounted on the NQPACK, and then align the index mark (the only corner with an angle cut-out) of the HQPACK with the index mark of the NQPACK, and insert it (See "Figure 5").

The HQPACK pins are thin and easy to bend. Check that the HQPACK pins are not bent before inserting it into the NQPACK.

3. Insert each of the screws for securing the HQPACK into each of the four screw holes on the HQPACK and tighten the diagonally opposite screws in turn.

To tighten the screws, use the special screwdriver supplied with the NQPACK to finally tighten the four screws in sequence. Tightening the screws too tight might result in a defective contact.

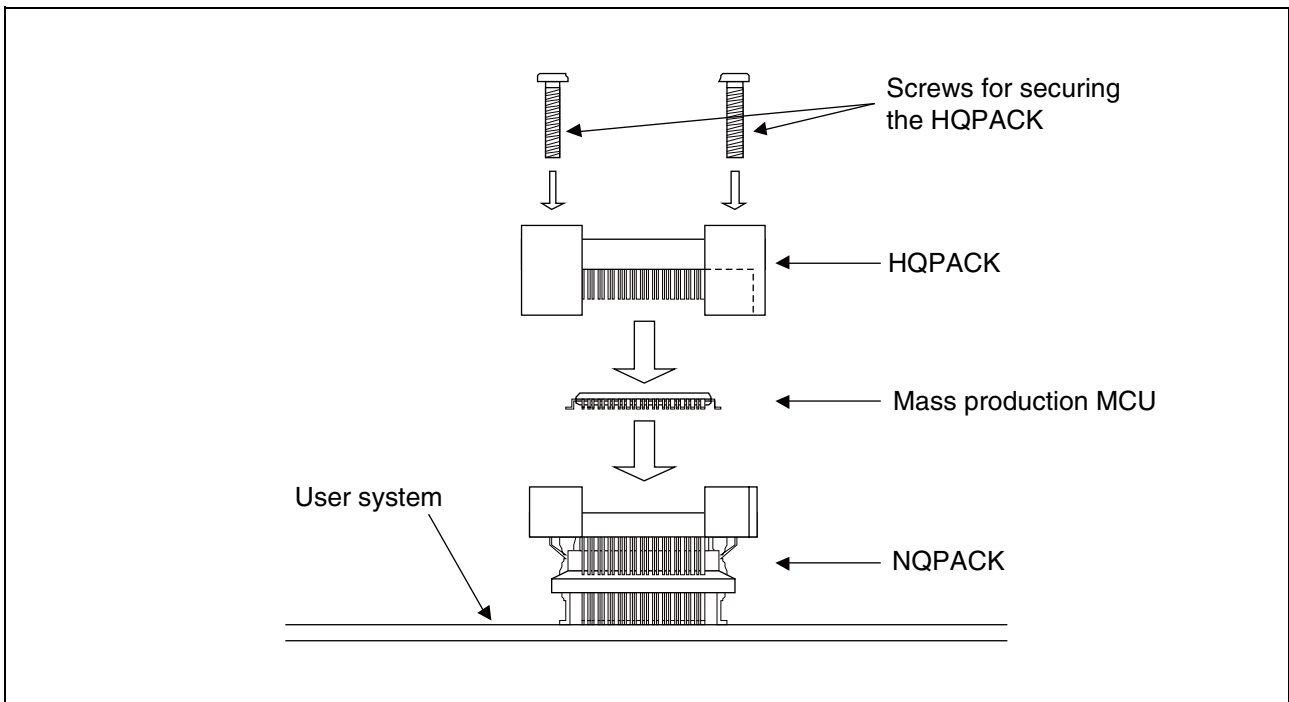

Figure 5 Mounting a mass production MCU

■ Disconnection

To remove the HQPACK, remove all of the four screws, and pull the HQPACK vertically out from the NQPACK.

6. Connector Pin Assignment

The signals from the evaluation MCU mounted on the adapter board are connected to the YQPACK (the same assignments as mass production MCU) via adapter I/F connectors 1 and 2 on the header board.

For details on the mass production MCU pins, refer to the data sheet or hardware manual of each MCU.

■ Pin assignment

Tables 1 to 4 show the correspondence between the pin numbers for adapter I/F connectors 1 and 2, the evaluation MCU on the adapter board, and the mass production MCU.

The following explanations apply to these tables. Row A corresponds to the side of the connector that displays the polarity. Row B corresponds to the opposite side.

*1 : No connection. These are not connected on either evaluation MCUs or mass production MCUs.

*2 : Pin 18 on mass production MCUs is connected to pins AA38, Y37, Y36, and Y35 on evaluation MCUs.

- : Unconnected (open) pin

 : VCC

The evaluation MCU power supply pins (VCC) are as follows:

VCC=Y38, W38, W36, W35, G5, L5, AR7, AM35, H35, D8, R5, W5, AC5, AG5, AP11, AP19, AP23, AP31, AH34, AD34, T34, H34, E32, E28, E20, E12, G4, AL4, AR31, D32, AL5, AP7, AP15, AP27, AR7, AM34, Y34, M34, E24, E16, E8, AP33, AP29, AP25, AP21, AP13, AA5, D15, D25, R35, AE35, AR24, P4, AP17, AP9, AN5, AJ5, AE5, U5, N5, J5, AR14, AD4, AK34, AF34, AB34, V34, P34, K34, F34, E30, E26, E22, E18, E14, E10, E6

The mass production MCU power supply (VCC) pin numbers are 16 and 48.

 : VSS

The evaluation MCU ground pins (VSS) are as follows:

VSS = E11, E15, E19, E23, E27, E31, G34, L34, R34, W34, AA34, AE34, M5, C3, B37, T5, Y5, AD5, AJ34, AH5, AT36, AT3, AU37, AU2, AK5, AP8, AP12, AP16, AP20, AP24, AP28, AP30, AL34, A1, B1, AU1, AV1, AV2, AV37, AV38, AU38, B38, A38, A37, A2, C36, D4, AR4, AR35, D35, E5, K5, P5, V5, AB5, AF5, AM5, AP5, AP6, AP10, AP14, AP18, AP22, AP26, AP32, AP34, AN34, AG34, AC34, U34, N34, J34, E34, E33, E29, E25, E21, E17, E13, E7

The mass production MCU ground (VSS) pin numbers are 17, 33, and 49.

Table 1 Adapter I/F Connector 1 (Row A)

Connector Pin No.	Mass Production MCU Pin No.	Evaluation MCU Pin No.	Connector Pin No.	Mass Production MCU Pin No.	Evaluation MCU Pin No.
A1	VCC		A51	GND	
A2	VCC		A52	GND	
A3	-	J36	A53	-	C30
A4	-	H37	A54	-	A32
A5	-	K36	A55	-	C31
A6	-	J35	A56	-	D30
A7	-	J83	A57	-	B31
A8	-	K35	A58	-	D31
A9	-	J37	A59	-	B32
A10	-	K38	A60	-	A33
A11	GND		A61	GND	
A12	GND		A62	GND	
A13	-	E38	A63	61	D28
A14	-	F37	A64	62	A30
A15	-	F38	A65	59	D29
A16	-	G35	A66	60	C28
A17	-	G38	A67	-	B29
A18	-	H36	A68	-	C29
A19	-	G37	A69	-	B30
A20	-	H38	A70	-	A31
A21	GND		A71	GND	
A22	GND		A72	GND	
A23	-	C38	A73	32	C26
A24	-	D37	A74	31	A28
A25	-	D38	A75	42	C27
A26	-	E35	A76	41	D26
A27	-	F36	A77	-	B27
A28	-	F35	A78	-	D27
A29	-	E37	A79	-	A29
A30	-	G36	A80	-	B28
A31	GND		A81	-	AC38
A32	GND		A82	-	AB36
A33	-	C34	A83	-	AC36
A34	-	A36	A84	-	AC35
A35	-	C35	A85	GND	
A36	-	B35	A86	-	AF38
A37	-	D36	A87	-	AD36
A38	-	B36	A88	-	AE36
A39	-	E36	A89	-	AG38
A40	-	C37	A90	-	-
A41	GND		A91	-	AD3
A42	GND		A92	-	AC3
A43	-	C32	A93	-	-
A44	-	A34	A94	VCC	
A45	-	C33	A95	GND	
A46	-	B33	A96	40	AD1
A47	-	D33	A97	GND	
A48	-	B34	A98	-	AD2
A49	-	D34	A99	GND	
A50	-	A35	A100	NC*1	

Table 2 Adapter I/F Connector 1 (Row B)

Connector Pin No.	Mass Production MCU Pin No.	Evaluation MCU Pin No.	Connector Pin No.	Mass Production MCU Pin No.	Evaluation MCU Pin No.
B1	-	-	B51	GND	
B2	-	-	B52	GND	
B3	-	B23	B53	57	B13
B4	-	A26	B54	58	A14
B5	-	B24	B55	-	C15
B6	-	C24	B56	56	B14
B7	-	B25	B57	54	B15
B8	-	C25	B58	55	C16
B9	-	B26	B59	-	B16
B10	-	A27	B60	53	A15
B11	GND		B61	GND	
B12	GND		B62	GND	
B13	51	C22	B63	22	B11
B14	52	A24	B64	21	A12
B15	47	C23	B65	24	C13
B16	50	B21	B66	23	B12
B17	45	D23	B67	13	C9
B18	46	B22	B68	12	B8
B19	43	A25	B69	-	A13
B20	44	D24	B70	-	D14
B21	GND		B71	GND	
B22	GND		B72	GND	
B23	-	D20	B73	-	B9
B24	-	B20	B74	-	A10
B25	-	D21	B75	-	C11
B26	-	A21	B76	-	B10
B27	-	C21	B77	-	D11
B28	-	A22	B78	-	C12
B29	-	D22	B79	-	D12
B30	-	A23	B80	-	A11
B31	GND		B81	-	AD38
B32	GND		B82	-	AA37
B33	-	D18	B83	-	AB37
B34	-	A18	B84	-	AD35
B35	-	D19	B85	-	AE38
B36	-	B19	B86	-	AC37
B37	-	C19	B87	-	AD37
B38	-	A19	B88	-	AE37
B39	-	C20	B89	GND	
B40	-	A20	B90	-	-
B41	GND		B91	-	L4
B42	GND		B92	-	L3
B43	26	D16	B93	-	-
B44	25	A16	B94	VCC	
B45	-	C17	B95	18	*2
B46	27	D17	B96	-	-
B47	29	C18	B97	-	-
B48	28	B17	B98	-	-
B49	-	A17	B99	-	-
B50	30	B18	B100	NC*1	

Table 3 Adapter I/F Connector 2 (Row A)

Connector Pin No.	Mass Production MCU Pin No.	Evaluation MCU Pin No.	Connector Pin No.	Mass Production MCU Pin No.	Evaluation MCU Pin No.
A1	VCC		A51	GND	
A2	VCC		A52	GND	
A3	11	B7	A53	3	J1
A4	10	A8	A54	2	L2
A5	-	C14	A55	5	C2
A6	-	D13	A56	4	D3
A7	15	C10	A57	7	B3
A8	14	D9	A58	6	C4
A9	20	A9	A59	9	B4
A10	19	D10	A60	8	C5
A11	GND		A61	GND	
A12	GND		A62	GND	
A13	-	E2	A63	-	L1
A14	-	F2	A64	-	N2
A15	-	D1	A65	-	N4
A16	-	F4	A66	-	N3
A17	-	C1	A67	-	M4
A18	-	E4	A68	-	M3
A19	-	D2	A69	-	K1
A20	-	E3	A70	-	M2
A21	GND		A71	GND	
A22	GND		A72	GND	
A23	-	H4	A73	-	N1
A24	-	J4	A74	-	P1
A25	-	F1	A75	-	R3
A26	-	H2	A76	-	T2
A27	-	E1	A77	-	P3
A28	-	G2	A78	-	R2
A29	-	F3	A79	-	M1
A30	-	G3	A80	-	P2
A31	GND		A81	-	AF37
A32	GND		A82	-	AF36
A33	-	K3	A83	-	AG36
A34	-	K4	A84	-	AG37
A35	-	H1	A85	GND	
A36	-	K2	A86	-	AK38
A37	-	G1	A87	-	AH36
A38	-	J2	A88	-	AJ36
A39	-	H3	A89	-	AL38
A40	-	J3	A90	39	AE1
A41	GND		A91	37	AE2
A42	GND		A92	-	-
A43	-	D5	A93	63	A6
A44	-	A3	A94	64	C8
A45	-	D6	A95	64	E9
A46	-	A4	A96	VCC	
A47	-	C7	A97	GND	
A48	-	C6	A98	-	AB38
A49	-	A5	A99	GND	
A50	-	B5	A100	GND	

Table 4 Adapter I/F Connector 2 (Row B)

Connector Pin No.	Mass Production MCU Pin No.	Evaluation MCU Pin No.	Connector Pin No.	Mass Production MCU Pin No.	Evaluation MCU Pin No.
B1	-	-	B51	-	L37
B2	-	-	B52	-	M38
B3	-	-	B53	-	M37
B4	-	-	B54	GND	
B5	-	R1	B55	-	N35
B6	-	U4	B56	-	N36
B7	-	V2	B57	-	P35
B8	-	U3	B58	-	P36
B9	-	U2	B59	-	P38
B10	-	T3	B60	-	N38
B11	-	R4	B61	GND	
B12	-	T4	B62	-	N37
B13	GND		B63	-	R36
B14	GND		B64	-	P37
B15	-	W2	B65	-	R37
B16	-	W3	B66	-	T36
B17	-	V1	B67	-	T37
B18	-	W4	B68	-	R38
B19	-	U1	B69	-	T35
B20	-	V4	B70	-	T38
B21	-	T1	B71	-	U35
B22	-	V3	B72	GND	
B23	GND		B73	-	U37
B24	GND		B74	-	U36
B25	-	AA1	B75	-	V37
B26	-	AB1	B76	-	V36
B27	-	Y2	B77	-	V38
B28	-	AA4	B78	-	U38
B29	-	Y1	B79	GND	
B30	-	Y4	B80	-	V35
B31	-	W1	B81	-	AH38
B32	-	Y3	B82	-	AF35
B33	GND		B83	-	AG35
B34	GND		B84	-	AH37
B35	-	AC1	B85	-	AJ38
B36	-	AC2	B86	-	AH35
B37	-	AB4	B87	-	AJ35
B38	-	AC4	B88	-	AJ37
B39	-	AB2	B89	GND	
B40	-	AB3	B90	38	AF2
B41	-	AA2	B91	-	-
B42	-	AA3	B92	-	-
B43	GND		B93	1	D7
B44	GND		B94	1	B6
B45	-	L36	B95	63	A7
B46	-	K37	B96	VCC	
B47	-	L35	B97	GND	
B48	-	M36	B98	34	AA36
B49	-	M35	B99	GND	
B50	-	L38	B100	35	AB35

SS01-71060-1E

FUJITSU SEMICONDUCTOR • SUPPORT SYSTEM

DSU-FR EMULATOR
LQFP-64P HEADER TYPE 2
MB2198-304
OPERATION MANUAL

February 2007 the first edition

Published **FUJITSU LIMITED** Electronic Devices

Edited Business Promotion Dept.

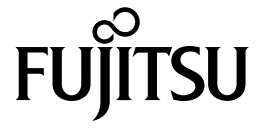

Free Manuals Download Website

<http://myh66.com>

<http://usermanuals.us>

<http://www.somanuals.com>

<http://www.4manuals.cc>

<http://www.manual-lib.com>

<http://www.404manual.com>

<http://www.luxmanual.com>

<http://aubethermostatmanual.com>

Golf course search by state

<http://golfingnear.com>

Email search by domain

<http://emailbydomain.com>

Auto manuals search

<http://auto.somanuals.com>

TV manuals search

<http://tv.somanuals.com>