

**DSU-FR emulator**  
**PGA-401P adapter type2**  
**MB2198-130**  
**Operation Manual**



## PREFACE

Thank you for purchasing the DSU-FR emulator PGA-401P adapter, Type 2 (model MB2198-130). The MB2198-130 is a development support tool for developing and evaluating applied products based on the FR family of microcontrollers manufactured by Fujitsu.

This manual is intended for engineers who use the MB2198-130 (hereafter called the adapter) to develop applied products based on Fujitsu's FR family microcontrollers. The manual describes how to handle the adapter and its functions and setting procedures. Be sure to read it before using the adapter.

\* : FR is the abbreviation of FUJITSU RISC controller.

### ■ Using the product safely

This manual contains important information required for using the MB2198-130 safely. Be sure to read through the manual before using the product and follow the instructions contained therein to use it correctly.

In particular, carefully read "Caution of the products described in this manual" at the beginning of this manual and Chapter 6 "Restrictions" to understand the requirements for safe use of the product before using it.

After reading the manual, keep it handy for future reference.

### ■ Warranty and Liability Disclaimers

The specifications of the product are subject to change without notice.

Fujitsu assumes no liability for any loss or damage whatsoever directly or indirectly arising out of the use of the product.

### ■ Product Operating Environment

Use the product at an operating temperature between 5 °C and 35 °C and at an operating humidity between 20% to 80%. Avoid using it in a hot or humid environment and prevent condensation.

The product is a frameless PC board unit with all electronic components exposed. Therefore, do not put anything on the product, do not touch or let an electrically charged material contact a metal part of it. Once the product has been powered, try to keep those objects away from it which may short-circuit it or easily catch fire and burn. Use the product as horizontal as possible and avoid operating it at a place exposed to strong vibration, dust, or explosive gas.

Note that using the product not in the above operating environment may unexpectedly cause personal injury to the user (or another person if present near the product) or physical damage to properties around the product.

You should also keep the packaging materials used for shipping the product. They work well as they are when you transport the product again, for example, if it becomes out of order and needs to be repaired.

## ■ Organization of this manual

This manual consists of the following six chapters. Be sure to read them all before using the product.

### Chapter 1 Product Overview and Handling Precautions

This chapter provides an overview of the MB2198-130 and its handling precautions.

### Chapter 2 Product Description

This chapter describes the configuration of the hardware system incorporating the MB2198-130 and shows the names of its components as well as the major specifications.

### Chapter 3 Functions

This chapter describes the functions of the MB2198-130.

### Chapter 4 Connections

This chapter explains how to connect the MB2198-130. Read this chapter before turning the power supply on.

### Chapter 5 Usage

This chapter explains how to set the MB2198-130 and how to turn the power supply on and off.  
Read this chapter before turning the power supply on.

### Chapter 6 Cautions

This chapter describes restrictions on using the MB2198-130. Read this chapter before turning the power supply on.

### Appendix User Interface Specification

The appendix explains user interface specification.

## ■ Related Manuals

You should refer to the following manuals as well:

- Evaluation MCU Hardware Manual or Datasheet
- Header Operation Manual
- DSU-FR Emulator MB2198-01 Hardware Manual
- SOFTUNE Workbench Operation Manual
- SOFTUNE Workbench User's Manual

## ■ Caution of the products described in this manual

The following precautions apply to the product described in this manual.



Indicates a potentially hazardous situation which, if not avoided appropriately, could result in death or serious injury and/or a fault in the user's system.

<b>Electric shock, Damage</b>	Before performing any operation described in this manual, turn off all the power supplies to the system. Performing such an operation with the power on may cause an electric shock or device fault.
<b>Electric shock, Damage</b>	Once the product has been turned on, do not touch any metal part of it. Doing so may cause an electric shock or device fault.



## CAUTION

Indicates a potentially hazardous situation which, if not avoided appropriately, may result in minor or moderate injury and/or damage to the product or the equipment to which the product is connected, to software resources such as data, or to other properties.

<b>Cuts, Damage</b>	Before moving the product, be sure to turn off all the power supplies and unplug the cables. Watch your steps when carrying the product. Do not use the product at an unstable location such as a place exposed to strong vibration or a sloping surface. Doing so may let the product fall, resulting in an injury or fault.
<b>Cuts</b>	The product has some sharp-pointed or edged parts inevitably exposed, such as jumper plugs. Use meticulous care in handling the product not to get injured with such pointed parts.
<b>Damage</b>	Neither put anything on or apply shock to the product. Once the product has been powered, do not carry it. Doing either may cause a fault due to a load or shock.
<b>Damage</b>	Since the product contains many electronic components, keep it away from direct sunlight, high temperature, and high humidity to prevent condensation. Do not use or store the product where it is exposed to much dust or a strong magnetic or electric field for an extended period of time. An adverse operating or storage environment can cause a fault.
<b>Damage</b>	Use the product within the ranges of its general specifications. Operating it outside the range of any general specification may cause a fault.
<b>Damage</b>	To prevent electrostatic breakdown, do not let your finger or an object touch any metal part of the connector. Before handling the product, touch a metal object (such as a door knob) to discharge static electricity from your body.
<b>Damage</b>	When turning the power on or off, follow the relevant procedure described in this manual. Before turning the power on, in particular, be sure to finish making all the required connections. To set up and use the product, follow the instructions given in this manual. Using the product incorrectly or inappropriately may cause a fault.
<b>Damage</b>	Before plugging or unplugging any cable for this product, be sure to turn the power supply off. When unplugging the cable, remove it while holding the connector without pulling the cable itself. Pulling the cable itself or bending it may expose or disconnect the cable core, resulting in a fault.
<b>Damage</b>	Although the MCU socket is structured not to accept an evaluation MCU in a wrong orientation or position, pay due attention to the mounting orientation when mounting the evaluation MCU. Forcing the evaluation MCU to be inserted in a wrong orientation can damage the pins of the evaluation MCU and the accidental insertion prevention mechanism of the socket, resulting in a fault.
<b>Damage</b>	When stored, the product should be kept in its packaging box as it has no housing. Re-transporting the product may damage it to cause a fault. Keep the packaging materials used for shipment of the product and use them when re-transporting it.

- The contents of this document are subject to change without notice.  
Customers are advised to consult with FUJITSU sales representatives before ordering.
- The information, such as descriptions of function and application circuit examples, in this document are presented solely for the purpose of reference to show examples of operations and uses of FUJITSU semiconductor device; FUJITSU does not warrant proper operation of the device with respect to use based on such information. When you develop equipment incorporating the device based on such information, you must assume any responsibility arising out of such use of the information. FUJITSU assumes no liability for any damages whatsoever arising out of the use of the information.
- Any information in this document, including descriptions of function and schematic diagrams, shall not be construed as license of the use or exercise of any intellectual property right, such as patent right or copyright, or any other right of FUJITSU or any third party or does FUJITSU warrant non-infringement of any third-party's intellectual property right or other right by using such information. FUJITSU assumes no liability for any infringement of the intellectual property rights or other rights of third parties which would result from the use of information contained herein.
- The products described in this document are designed, developed and manufactured as contemplated for general use, including without limitation, ordinary industrial use, general office use, personal use, and household use, but are not designed, developed and manufactured as contemplated (1) for use accompanying fatal risks or dangers that, unless extremely high safety is secured, could have a serious effect to the public, and could lead directly to death, personal injury, severe physical damage or other loss (i.e., nuclear reaction control in nuclear facility, aircraft flight control, air traffic control, mass transport control, medical life support system, missile launch control in weapon system), or (2) for use requiring extremely high reliability (i.e., submersible repeater and artificial satellite).  
Please note that FUJITSU will not be liable against you and/or any third party for any claims or damages arising in connection with above-mentioned uses of the products.
- Any semiconductor devices have an inherent chance of failure. You must protect against injury, damage or loss from such failures by incorporating safety design measures into your facility and equipment such as redundancy, fire protection, and prevention of over-current levels and other abnormal operating conditions.
- If any products described in this document represent goods or technologies subject to certain restrictions on export under the Foreign Exchange and Foreign Trade Law of Japan, the prior authorization by Japanese government will be required for export of those products from Japan.

# CONTENTS

Chapter 1 Product Overview and Handling Precautions .....	1
1.1 Overview .....	2
1.2 Checking the Items Packaged .....	3
1.3 Options .....	4
1.4 Notes on Use .....	5
Chapter 2 Product Description .....	7
2.1 System Configuration .....	8
2.2 Appearance and Part Names .....	9
2.3 General Specifications .....	11
Chapter 3 Functions .....	13
3.1 Function Specifications .....	14
3.2 Connector and IC Socket Specifications .....	15
Chapter 4 Connections .....	17
4.1 Connecting the Adapter Board to the Emulator .....	18
4.2 Connecting the Adapter Board with the Header Board .....	19
4.3 Installing the Evaluation MCU.....	20
4.4 Installing the Memory Board .....	22
4.5 Installing a Bypass Capacitor for DVCC .....	24
Chapter 5 Usage .....	25
5.1 Setting up the Evaluation MCU Power Supply .....	26
5.2 Setting the Clock Supply Circuit .....	28
5.3 Setting a Reset Signal .....	30
5.4 Setting a External Memory Emulation .....	31
5.5 Power-on/Shutdown Procedures .....	33
Chapter 6 Cautions .....	35
APPENDIX User Interface Specifications .....	37

# Chapter 1 Product Overview and Handling Precautions

---

This chapter provides an overview of the adapter and its handling precautions.

---

- 1.1 Overview
- 1.2 Checking the Items Packaged
- 1.3 Options
- 1.4 Notes on Use



## 1.1 Overview

---

This adapter is a development support tool for developing and evaluating hardware and software products which use the Fujitsu's FR family of microcontrollers.

---

### ■ Overview

The adapter is intended for use in combination with another device such as DSU-FR emulator header \*1 to connect a FR-microcontroller based user system to the DSU-FR emulator (MB2198-01 \*2).

\*1 : Hereafter called the header.

\*2 : Hereafter called the emulator.

The major features of the adapter are listed below:

- The adapter consists of the adapter board and flat cables (two standard and two long cables).
- The adapter board has an on-board IC socket for evaluation MCU (401-pin PGA package code: PGA-401C-A02).
- Connected to the header using a flat cable (standard or long one)
- Used in combination with the header to connect the emulator and the user system
- Power to the adapter is supplied from the user system via the emulator or header.
- Internal ROM emulation memory function supported
- External memory emulation function supported
- External trace function supported
- Power-on debug function supported

## 1.2 Checking the Items Packaged

---

Check that your package is complete before using the adapter.

---

### ■ Checking the Items Packaged

Before using the adapter, make sure that your package contains the following items:

- Adapter board: 1
- Flat cables (Standard: 8 cm): 2
- Flat cables (Long: 20 cm): 2
- Hardware manual (This manual in English and a Japanese version): 1 each

Note : Keep the packaging materials used for shipment of the product and use them when re-transporting it to prevent it from being damaged.

## 1.3 Options

Table 1.3-1 lists the options for this product. Purchase them as required.

### ■ Options

Table 1.3-1 Options

Name	Part number
Evaluation MCU	Fujitsu FR family controller (MB91Vxxx) *1
DSU-FR emulator	MB2198-01 *2
DSU-FR emulator header	MB2198-XXX *3
DSU-FR emulator memory board *4	—
Oscillator, Capacitor *5	—

\*1 : The package code of the evaluation MCU is PGA-401C-A02. For the evaluation MCU models available to this adapter and their package codes, Please ask, when unknown.

\*2 : You need optional items such as debugger software and a communication cable before the emulator can be used.

For details, Please ask, when unknown.

\*3 : The header is the interface board to connect the user system to the emulator.

Select and purchase the appropriate type of header compatible with the production MCU model to be used.

Refer to the "Header Instruction Manual" for how to handle and use the header and safety precautions.

\*4 : The memory board is required to use the external-memory emulation function (under planning).

\*5 : Refer to the data sheet of evaluation MCU about the frequency of the oscillator to be used. For the capacitance of the capacitor, refer to the data sheet for the oscillator.

## 1.4 Notes on Use

---

Take the precautions below when using the adapter.

---

### ■ Handling Precautions

- Do not put anything on the adapter.
- Before plugging or unplugging any cable, be sure to turn the power supply off.
- When unplugging the cable, remove it while holding the case connector without pulling the cable itself.
- To prevent electrostatic breakdown, do not let your finger or an object touch any metal part of the adapter, such as connector pins.
- The adapter has many exposed parts sharp-pointed and edged such as monitor pins. Handle the adapter with meticulous care not to get injured.

Note : To set up and use the adapter, follow the instructions in this manual.

### ■ Storing Precautions

- Do not put anything on the product. When stored, the product should be kept in the packing box as it has no housing.
- Do not apply shock to the adapter.
- Keep the device away from direct sunlight, high temperature, and high humidity to prevent condensation.
- Since the product contains many electronic components, do not store it where it is exposed to a strong electric or magnetic field for an extended period of time.

Table 1.4-1 lists the operating and storage temperatures and humidities.

Table 1.4-1 Operating and Storage Environments

	Temperature	Humidity
During operation	5 °C to 35 °C	20% to 80% (No condensation allowed)
During storage	0 °C to 70 °C	20% to 80% (No condensation allowed)

---

Memo

---

## Chapter 2 Product Description

---

This chapter describes the configuration of the hardware system incorporating the MB2198-130 and shows the names of its components as well as the major specifications.

---

- 2.1 System Configuration
- 2.2 Appearance and Part Names
- 2.3 General Specifications

## 2.1 System Configuration

Used in combination with the header, the adapter is connected to the emulator and the user system.

### ■ System Configuration

Figure 2.1-1 shows the system configuration for the adapter.

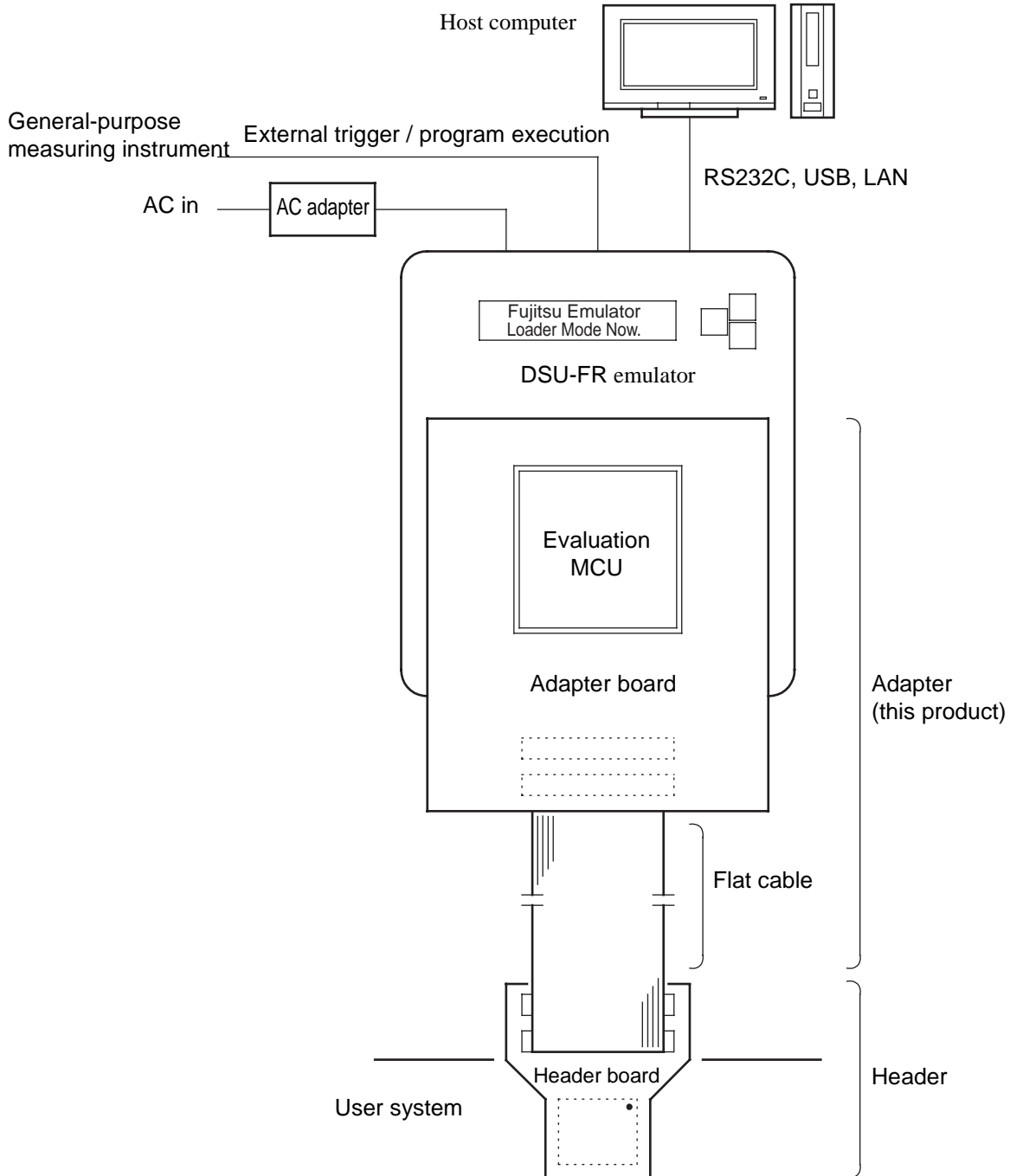

\*: The AC adapter is bundled with the emulator.

Figure 2.1-1 System Configuration Diagram

Refer to the emulator hardware manual for connecting the emulator to a host computer or general-purpose measuring instrument.

To use the emulator, you need the host computer and emulator debugger software separately from this product. Refer to the emulator hardware manual for information on the specifications of the emulator.

## 2.2 Appearance and Part Names

Figure 2.2-1 gives an external view of the adapter board to identify each part of it.

### ■ Appearance and Part Names

Figure 2.2-1 gives an external view of the adapter board to identify each part of it. The adapter board illustrated in Figure 2.2-1 is in the factory default states.

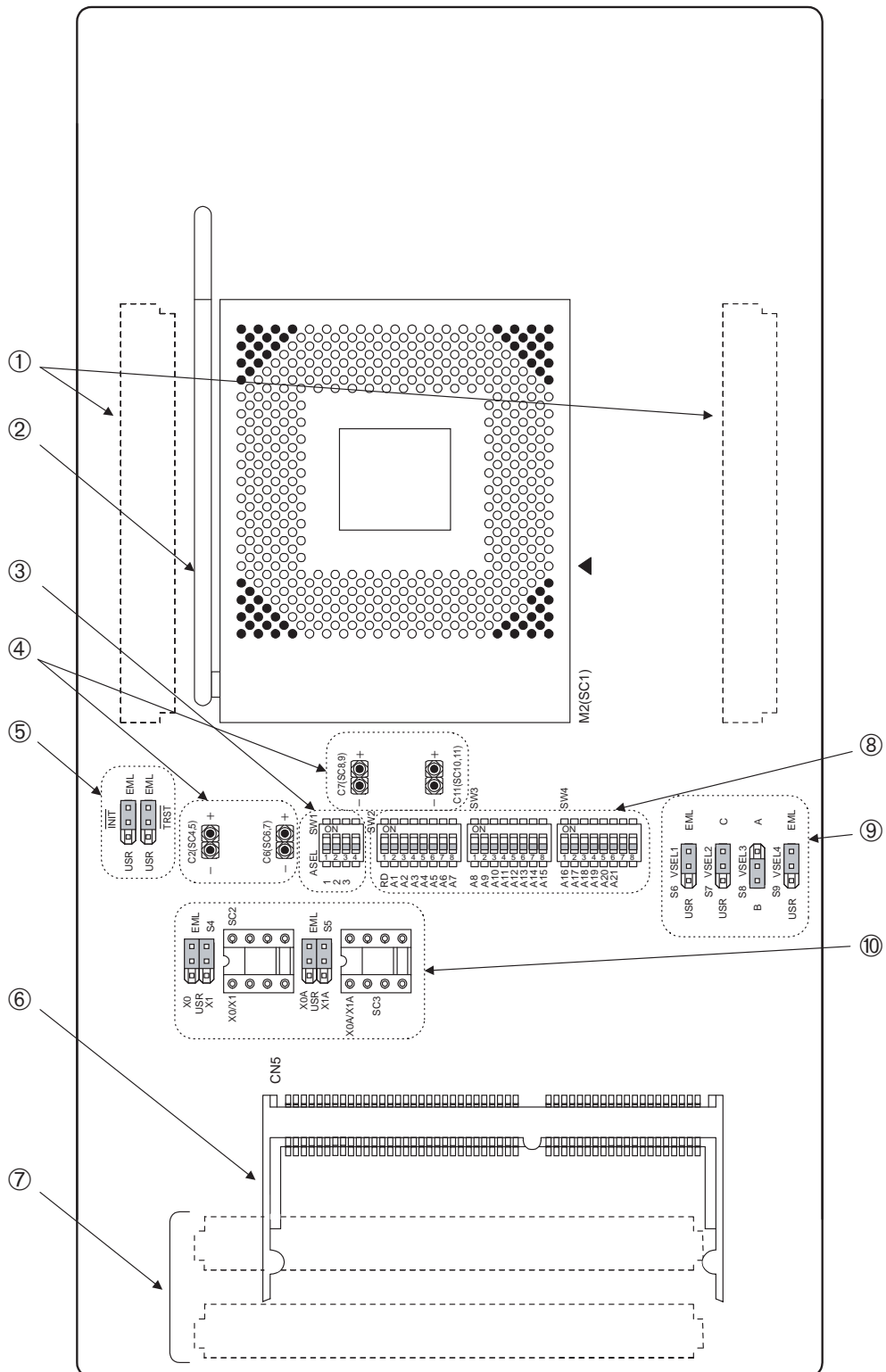

Figure 2.2-1 External View



① Emulator connector

This connector accepts the emulator (Mounted on the rear side).

② IC socket for evaluation MCU

401-pin PGA IC socket for mounting an evaluation MCU

③ Memory size select switch

This switch sets the capacity of the memory board to use external-memory emulation.

④ DVCC bypass capacitor sockets

These sockets accept bypass capacitors to be inserted between DVCC and GND pins.

⑤ Reset signal setting jumper plugs

These jumper plugs are used to set the reset signal supply origin.

⑥ Memory board connector

This connector accepts a memory board (for external-memory emulation).

⑦ Flat cable connectors

Use the bundled flat cables to connect the header to the adapter board (Mounted on the rear side).

⑧ Memory connective switches

These switches disconnect buffers so that signal conductors can be used without being loaded when external-memory emulation is not used or when address lines disabled by memory capacity switching are used as user resources.

⑨ Jumper plugs for setting the evaluation MCU power supply

These jumper plugs are used to make settings for the evaluation MCU.

⑩ Clock input IC sockets and clock input select jumper plugs

The IC sockets accept an oscillator and a capacitor for the main clock and subclock; the jumper plugs are used to set the clock supply source.

## 2.3 General Specifications

Table 2.3-1 lists the general specifications of the adapter.

### ■ General Specifications

Table 2.3-1 lists the general specifications of the adapter.

Table 2.3-1 General Specifications

Item	Specification	
Name	DSU-FR emulator PGA-401P adapter type 2	
Part number	MB2198-130	
Power supplies	Evaluation MCU: Internal power supply *	0 V to +5.5 V (UVcc)
	Evaluation MCU: I/O power supply *	0 V to +5.5 V (UVcc)
	Adapter board power supply	+3.3 V (Supplied from emulator)
Internal operating frequency of MCU	34 MHz max.	
Operating temperature	5 °C to 35 °C	
Operating humidity	20% to 80% (No condensation allowed)	
Dimensions	205 (W) × 110 (D) × 30 (H) mm (Including the IC socket and connector dimensions)	
Weight	173 g	

\* : For the internal power and I/O power supplied to each evaluation MCU, refer to the power supply specifications of the evaluation MCU. For each type of supplied power, refer to the "Evaluation MCU Hardware Manual" or Please ask, when unknown.

Note : Operating the device outside the range of any general specification may cause the device to malfunction. Use the device in the ranges of its general specifications.

---

Memo

---

## **Chapter 3 Functions**

---

This chapter describes the functions of the adapter.

---

### **3.1 Function Specifications**

### **3.2 Connector and IC Socket Specifications**

### 3.1 Function Specifications

Table 3.1-1 lists the major function specifications of the adapter.

#### ■ Function Specifications

Table 3.1-1 lists the major function specifications of the adapter. Figure 3.1-1 is a block diagram of external-memory emulation.

Table 3.1-1 Adapter Function Specifications

Item	Description	
Adapter Function	Serving as the adapter used in combination with the DSU-FR emulator and header to provide connection between the emulator and evaluation MCU and between the evaluation MCU and user system.	
External trace memory	Supporting the external trace function. Trace length of 64 K frames	
Internal ROM emulation	Supporting the internal ROM emulation memory function. 1 megabytes max. *1	
External-memory emulation	Supporting the external-memory emulation *2 function. Capable of setting RAM/ROM. This function is implemented by mounting an optional memory board on the adapter board.	
	Memory capacity switching	Capable of selecting the capacity of the memory board from among seven steps between 2M words and 32K words (1 word = 16 bits).
	Memory connection	Capable of disconnecting address lines disabled by the memory capacity switching function from buffers and using them as user resources instead. Also capable of reducing the load applied during use of such address lines as user resources by disconnecting them even when the external-memory emulation function is not used.
Power-on debugging	Supporting the power-on debug function *3 which runs a program immediately after the power-on sequence of the evaluation MCU.	
Jumper plugs	The jumper plugs on the adapter board can be used to make various settings of the adapter.	
Clock input IC sockets	The IC sockets for oscillator on the adapter board supply clock signals from the adapter to the main clock (X0/X1) and subclock (X0A/X1A) pins of the evaluation MCU.	

\*1 : The evaluation MCU must support the external-memory emulation feature. The total amount of memory available depends on the memory capacity of the memory board, its memory capacity select switch, and the settings of the evaluation MCU. Refer to the "Evaluation MCU Hardware Manual" or Please ask, when unknown before use. For details, see Section 5.4 "External-Memory Emulation Settings."

Note also that this function is added to the external bus of the evaluation MCU. Before using the function, read Chapter 6 "Cautions" carefully.

\*2 : This function assumes that the evaluation MCU supports the power-on debug feature. Refer to the "Evaluation MCU Hardware Manual" or Please ask, when unknown before use.

## 3.2 Connector and IC Socket Specifications

The table below lists the specifications of the connectors and sockets on the adapter board.

### ■ Connector and Socket Specifications

Table 3.2-1 lists the specifications of the connectors and sockets.

Table 3.2-1 Connector and IC Socket Specifications

Item	Description
Emulator connector	Use this connector to connect the emulator to the adapter. For connecting the emulator, see Section 4.1 "Connecting the Adapter Board and the Emulator".
Flat cable connectors	Connect the adapter to the header using flat cables coming with the adapter. For connecting the flat cables, see Section 4.2 "Connecting the Adapter Board and the Header Board".
Evaluation MCU mounting IC socket	Mount the evaluation MCU (PGA-401P package). For mounting the evaluation MCU, see Section 4.3 "Mounting the Evaluation MCU".
Memory board connector	Mount an optional memory board. For mounting the memory board, see Section 4.4 "Mounting the Memory Board".
Oscillator IC sockets	Mount an oscillator and a capacitor authorized for the oscillator. For mounting the oscillator and capacitor, see Section 5.2 "Set-up for Clock Supply".
DVCC bypass capacitor mounting sockets	If the evaluation MCU has an integrated digital power supply (such as a DVCC power supply), a bypass capacitor can be mounted on the digital power supply as required. For mounting the bypass capacitor, see Section 4.5 "Mounting the DVCC Bypass Capacitor".

---

Memo

---

## Chapter 4 Connections

---

This chapter explains how to connect individual devices before turning their power on.

---

- 4.1 Connecting the Adapter Board to the Emulator
- 4.2 Connecting the Adapter Board with the Header Board
- 4.3 Installing the Evaluation MCU
- 4.4 Installing the Memory Board
- 4.5 Installing a Bypass Capacitor for DVCC

Note : Shut off power to the entire system before starting the operations described in this chapter. Performing such operations with the power on may result in electric shock or device faults.  
When unplugging any cable, remove it while holding the case connector without pulling the cable itself.  
Do not force any cable to bend, or it may break.



## 4.1 Connecting the Adapter Board to the Emulator

Connect the adapter board to the adapter board connector on the emulator as illustrated in Figure 4.1-1.

### ■ Connecting the Adapter Board and the Emulator

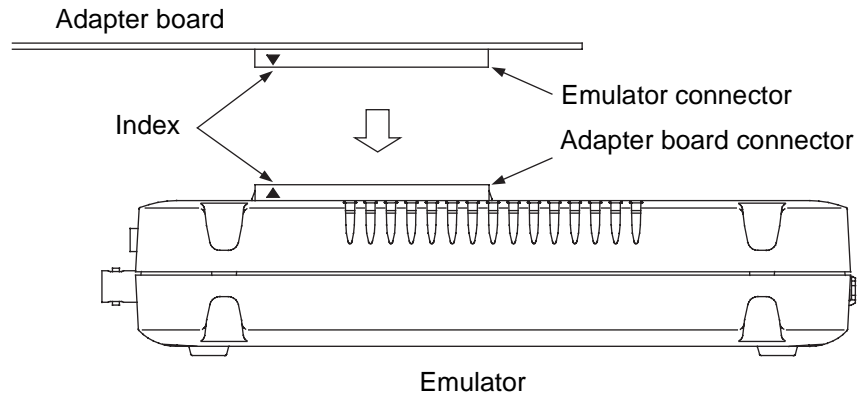

- Connect the adapter board to the emulator in such a manner that their connectors aligned by indexes (▲) provided to prevent accidental insertion mate deep with each other.
- When disconnecting the adapter board from the emulator, remove it with uniform force without applying force to one point.

Figure 4.1-1 Connecting the Adapter Board to the Emulator

Note : Before plugging or unplugging the board, turn off the power supply.

When unplugging the board, remove it with uniform force without applying force to one point.

## 4.2 Connecting the Adapter Board with the Header Board

Connect the adapter board with the header board using a flat cable coming with the adapter as illustrated in Figure 4.2-1.

### ■ Connecting the Adapter Board to the Header Board

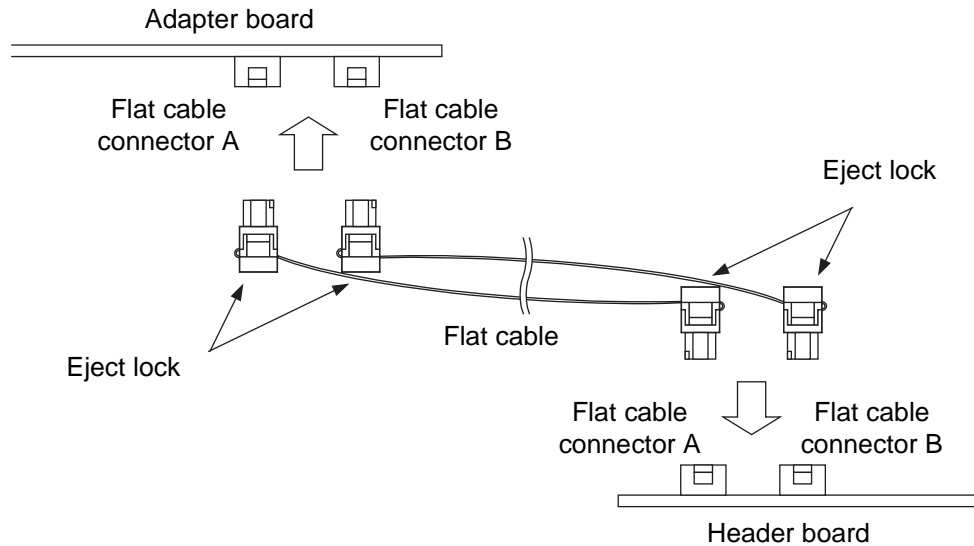

- To connect the flat cable, insert each of its connectors into the mating connector on each board until the eject lock of the cable's connector locks into place in the board's connector.
- To disconnect the flat cable, pinch the eject lock of each of its connectors to unlock the connector and unplug the cable.

Figure 4.2-1 Connecting the Adapter Board with the Header Board

Note : Before plugging or unplugging the cable, turn off the power supply.

When unplugging the cable, remove it while holding the case connector without pulling the cable itself.

### 4.3 Installing the Evaluation MCU

Install the evaluation MCU on the evaluation MCU mounting IC socket on the adapter board as illustrated in Figure 4.3-1 to Figure 4.3-3. To uninstall the evaluation MCU, follow the instruction illustrated in Figure 4.3-4.

#### ■ Installing the Evaluation MCU

Open the lever of the evaluation MCU mounting IC socket (SC1) to from the solid-line position to the dotted-line position.

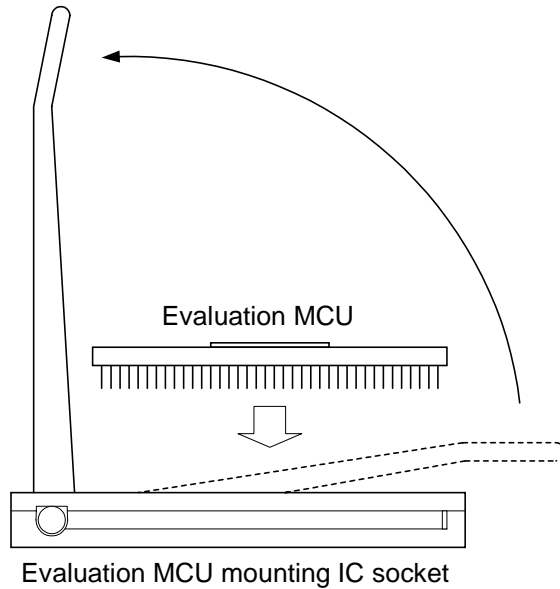

Figure 4.3-1 Installing the Evaluation MCU

#### ■ Mounting Position

Align pin No. 1 of the evaluation MCU with its pin hole in the evaluation MCU mounting IC socket (SC1) and insert the evaluation MCU horizontally. (Check this from above.)

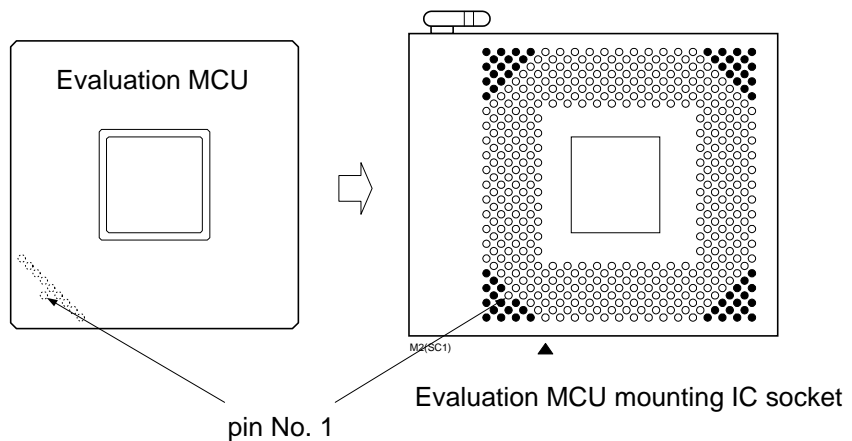

Figure 4.3-2 Mounting Position

### ■ Securing the Evaluation MCU

Close the lever of the evaluation MCU mounting IC socket (SC1) from the dotted-line position to the solid-line position to lock the evaluation MCU.

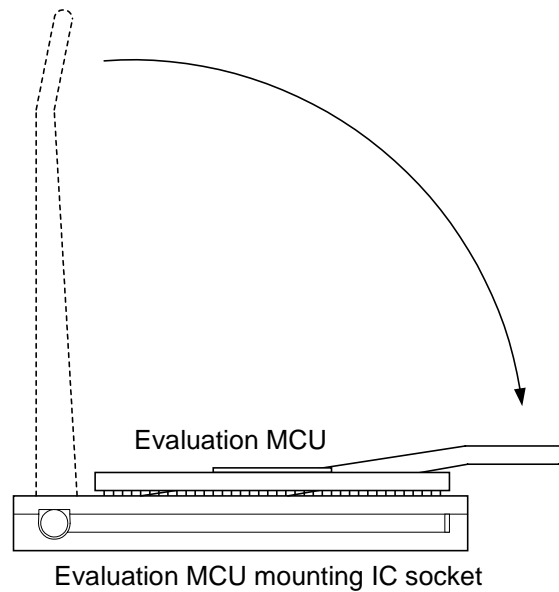

Figure 4.3-3 Securing the Evaluation MCU

### ■ Uninstalling the evaluation MCU

To uninstall the evaluation MCU, open the lever of the evaluation MCU mounting IC socket (SC1) from the dotted-line position to the solid-line position, then remove the evaluation MCU.

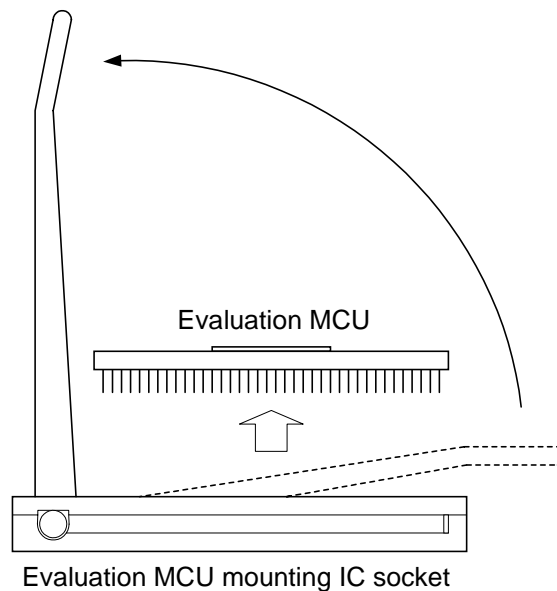

Figure 4.3-4 Uninstalling the Evaluation MCU

## 4.4 Installing the Memory Board

To use the external-memory emulation function, plug an optional memory board into the memory board connector on the adapter board as illustrated in Figures 4.4-1 to 4.4-3. To uninstall the memory board, follow the instruction illustrated in Figure 4.4-4.

### ■ Mounting Position

Align the dented part of the memory board on the right side with the raised part of the memory board connector.

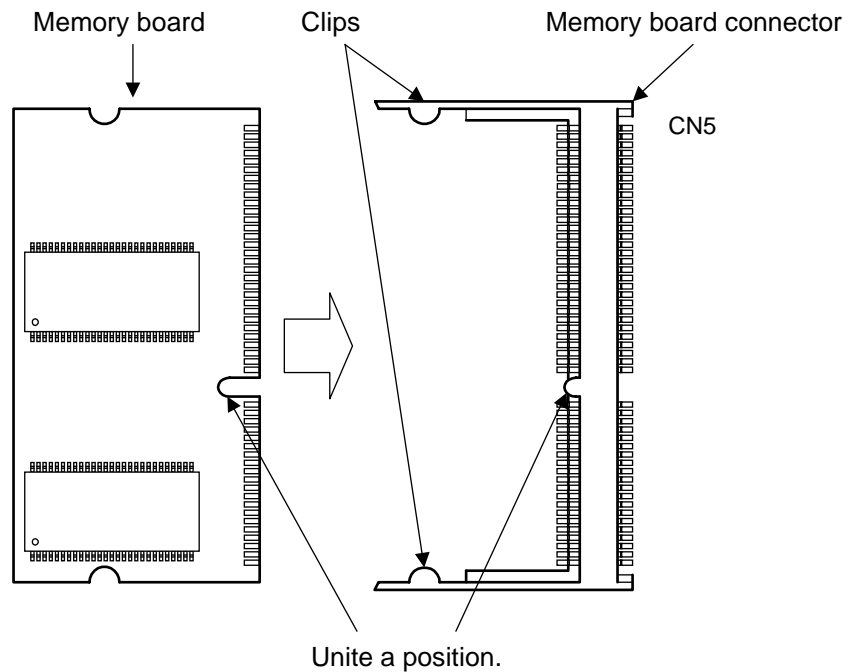

Figure 4.4-1 Mounting Position

### ■ Plugging the Memory Board

Push the memory board at a slant into the memory board connector as shown with Figure 4.4-1. (Check this from the side.)

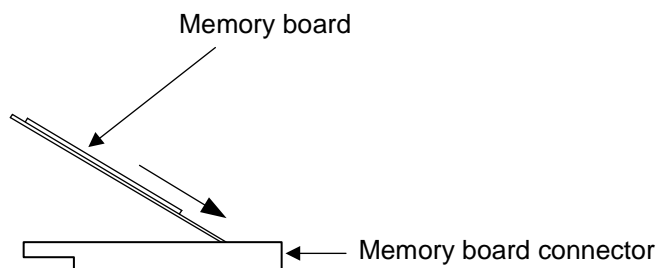

Figure 4.4-2 Plugging the Memory Board

### ■ Securing the Memory Board

Put the memory board down from the dotted-line position to the solid-line position and hold the memory board between the clips on both sides until it clicks into place to secure it.

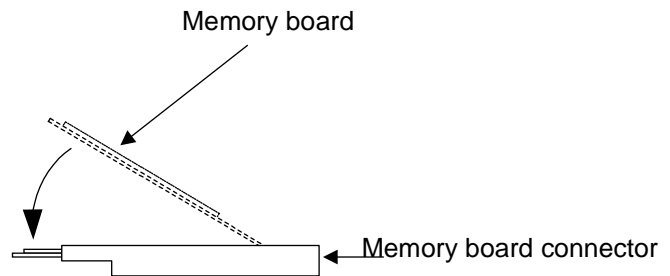

Figure 4.4-3 Securing the Memory Board

### ■ Uninstalling the Memory Board

To uninstall the memory board, open the clips on both sides of the memory board connector by pushing them outward (as shown in the left-side sketch in Figure 4.4-4).

Put the memory board up from the dotted-line position to the solid-line position to remove it (as shown in the right-side sketch in Figure 4.4-4).

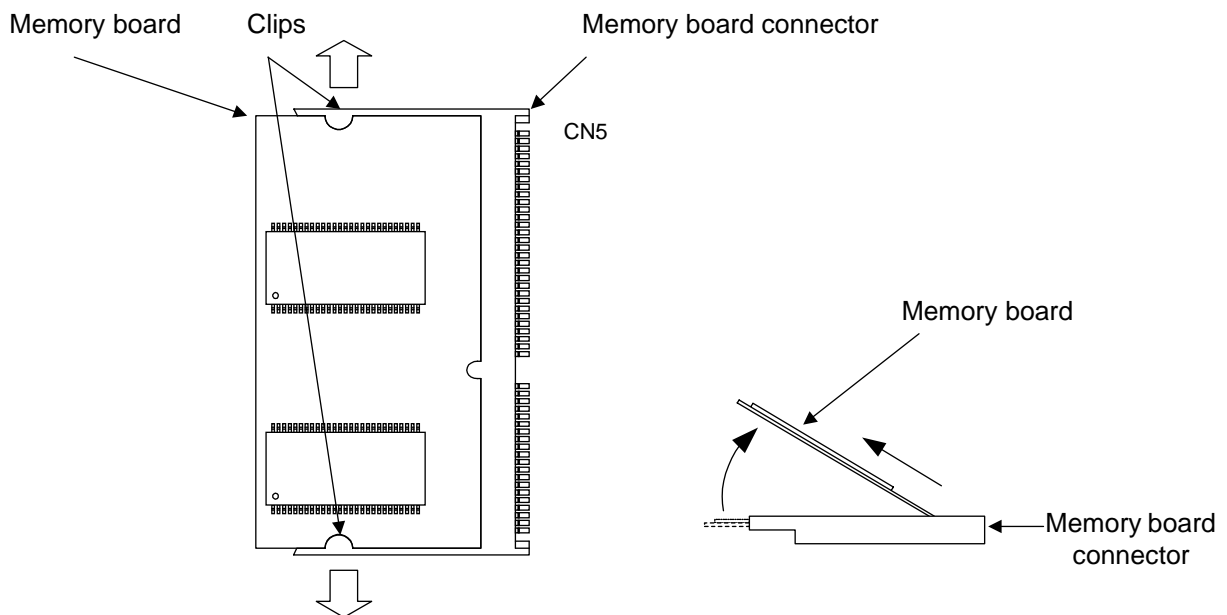

Figure 4.4-4 Uninstalling the Memory Board

## 4.5 Installing a Bypass Capacitor for DVCC

If the evaluation MCU has an integrated digital power supply ( DVCC pin), a bypass capacitor can be mounted on the digital power supply as required. When it does not have a digital power supply (DVCC pin) in Evaluation MCU, a bypass capacitor does not need to be mounted.

### ■ Installing a Bypass Capacitor

To use a polarized capacitor such as an electrolytic capacitor as the bypass capacitor, install it according to the polarity defined by the silk pattern on the PC board. Use meticulous care to check the polarity.

Select the appropriate capacitor so that its type, capacitance, and withstand voltage are best suited for the operating environment.

Figure 4-5-1 shows how to install the capacitor. Table 4.5-1 lists the signal names of digital power supply pins of the evaluation MCU plugged in each capacitor mounting socket.

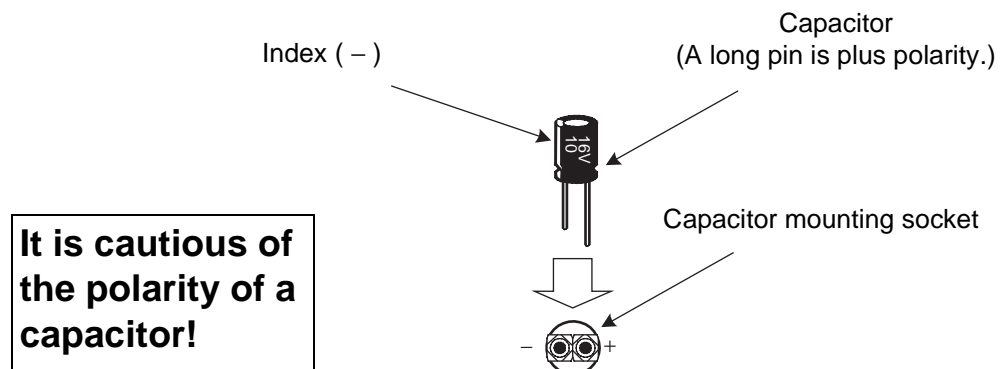

Figure 4.5-1 Mounting the Capacitor

Table 4.5-1 The Signal Names of Digital Power Supply Pins of the Evaluation MCU

Capacitor mounting socket name	Correspondence signal line	Evaluation MCU pin number
SC4, 5	PF2	127
SC6, 7	PD3	241
SC8, 9	P85	36
SC10, 11	P65	39

## Chapter 5 Usage

---

This chapter describes the basic setup procedures to be followed before turning the power on and the power-on and shutdown procedures as well.

Be sure to read this chapter before turning the power on.

---

5.1 Setting up the Evaluation MCU Power Supply

5.2 Setting the Clock Supply Circuit

5.3 Setting Reset Signals

5.4 Setting a External Memory Emulation

5.5 Power-on/Shutdown Procedures

Note : Shut off power to the entire system before starting the operations described in this chapter. Performing such operations with the power on may result in electric shock or device faults.



## 5.1 Setting up the Evaluation MCU Power Supply

Figure 5.1-1 shows the factory settings of the jumper plugs; Table 5.1-1 lists the evaluation MCU power supply specifications depending on the settings of individual jumper plugs from VSEL1 to VSEL4.

### ■ Setting up the Evaluation MCU Power Supply

Figure 5.1-1 shows the power supply circuit configuration around the evaluation MCU.

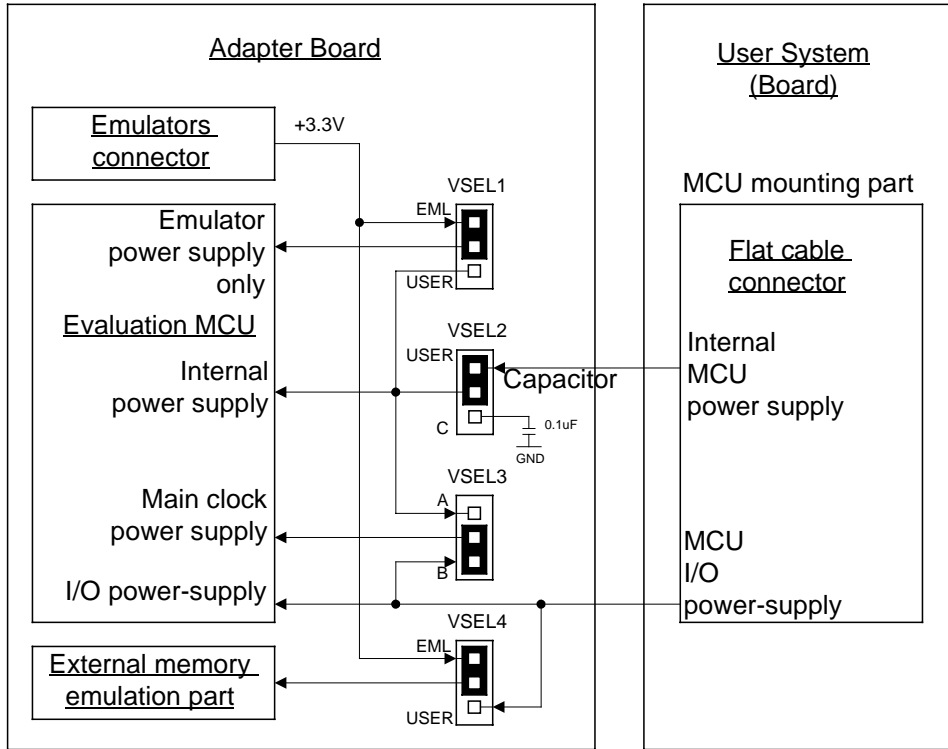

Figure 5.1-1 Settings of Evaluation MCU Power Supply Setup Jumper Plugs

### ■ Setting up the Evaluation MCU Power Supply

Table 5.1-1 lists the evaluation MCU power supply specifications depending on the settings of individual jumper plugs from VSEL1 to VSEL4.

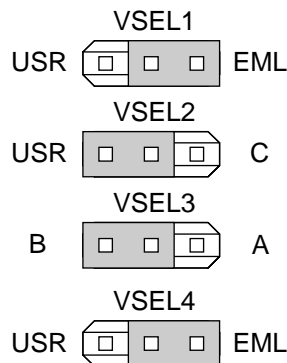

Figure 5.1-2 Settings of Evaluation MCU Power-Supply Setup Jumper Plugs (Factory Settings)

Table 5.1-1 Jumper Plug Settings

Jumper plug name	Setting	Evaluation MCU power supply specifications
VSEL1	USR side	The power supply only for emulators is supplied from a user system.
	EML side	The power supply only for emulators <sup>*1</sup> is supplied from a user system.
VSEL2	USR side	Supply evaluation MCU internal power or C pin <sup>*2</sup> from user system.
	C side	Add capacitor (0.1 $\mu$ F) to evaluation MCU internal power supply or C pin <sup>*2</sup>
VSEL3	A side	Supply VCCXTL power <sup>*3</sup> from evaluation MCU internal power supply.
	B side	Supply VCCXTL power <sup>*3</sup> from evaluation MCU external power supply. (Set "B" side)
VSEL4	USR side	Supply backup power <sup>*4</sup> from user system (evaluation MCU: external power supply) (for RAM) .
	EML side	Supply backup power <sup>*4</sup> from emulator (for ROM) . Please be sure to set up here the case where an external memory emulation function is not used.

\*1 : When using a power-on debugging function, it is necessary to supply the power supply only for emulators from an emulator (EML side), and Evaluation MCU needs to correspond to the power-on debugging function further. Whether Evaluation MCU deals with the power-on debugging function should look at "an evaluation MCU hardware manual" or a "data sheet." Please ask, when unknown.

\*2 : For the specifications of the internal power supply of each evaluation MCU, consult the evaluation MCU hardware manual or Please ask, when unknown.

\*3 : To supply VCCXTL power (power for main oscillation (clock generation)) from other than the evaluation MCU's internal or external power supply, remove the jumper plug to supply power from the user system.

\*4 : The backup power supply is used for the external-memory emulation circuit on the adapter board. To use the data backup function, supply backup power from the emulator. In this case, the emulator detects the power-on or shutdown state of the user system to back up data on the adapter board (ROM equivalent operation).

## 5.2 Setting the Clock Supply Circuit

To supply a clock signal from the adapter board to the main clock (X0/X1) and subclock (X0A/X1A) of the evaluation MCU, install an oscillator and a capacitor on the oscillator IC sockets (SC2 and SC3) on the adapter board, respectively. Figure 5.2-1 shows how to install the oscillator and capacitor.

### ■ Installing the Oscillator

To supply a clock signal from the adapter board to the main clock (X0/X1) and subclock (X0A/X1A) of the evaluation MCU, install an oscillator and a capacitor on the oscillator IC sockets (SC2 and SC3) on the adapter board, respectively. Figure 5.2-1 shows how to install the oscillator and capacitor.

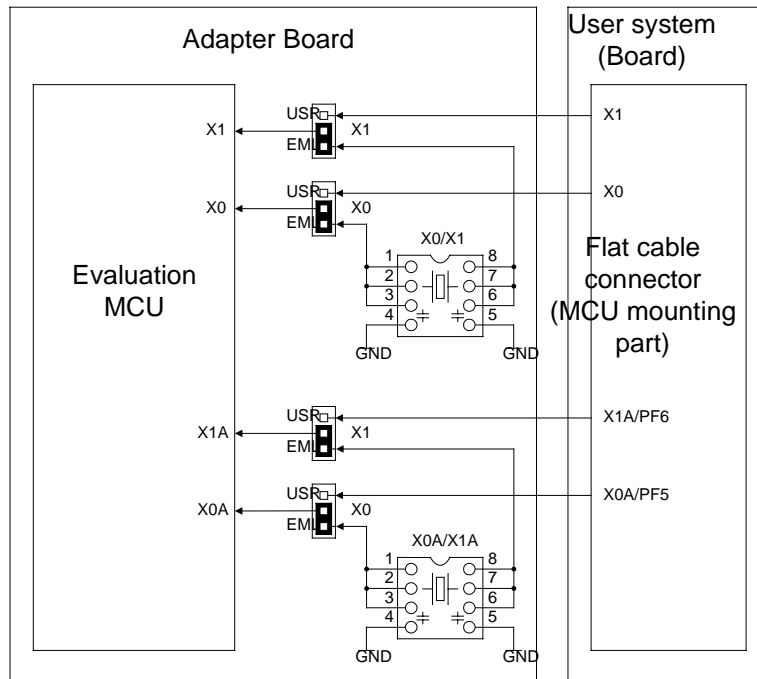
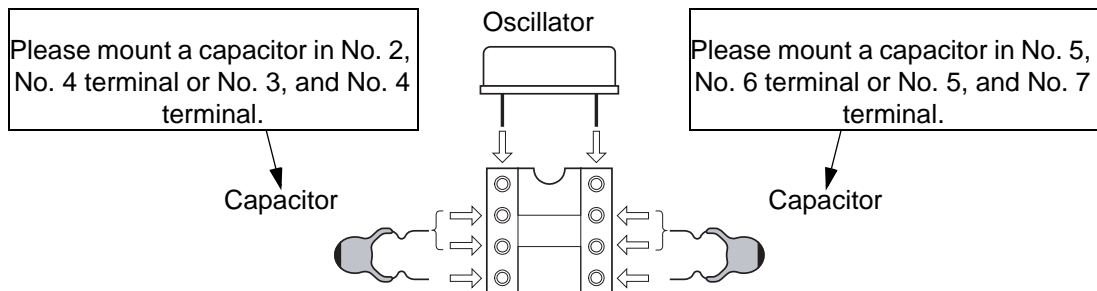

Figure 5.2-1 Installing the Oscillator and Capacitor

### ■ Installing the Oscillator

To supply a clock signal from the adapter board to the main clock (X0/X1) and subclock (X0A/X1A) of the evaluation MCU, install an oscillator and a capacitor on the oscillator IC sockets (SC2 and SC3) on the adapter board, respectively. Figure 5.2-1 shows how to install the oscillator and capacitor.



- For the frequency and other specifications of the oscillator, refer to the data sheet for the evaluation MCU.
- For the capacitance of the capacitor, refer to the data sheet for the oscillator.
- Prepare the oscillator and the capacitor as neither of them is bundled with this product.

Figure 5.2-1 Installing the Oscillator and Capacitor

## ■ Setting the Clock Selector Jumper Plugs

Figure 5.2-2 shows the factory settings of the jumper plugs; Table 5.2-1 shows how to set the clock selector jumper plugs.

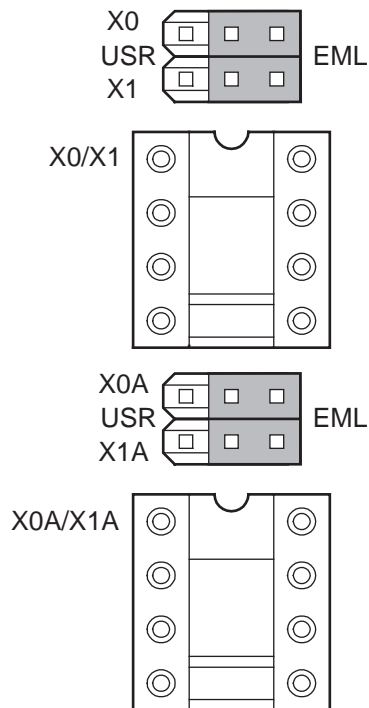

Figure 5.2-3 Setting the Clock Selector Jumper Plugs (Factory Setting)

Table 5.2-1 Jumper Plug Settings

Jumper plug name	Setting	Clock supply
X0,X1	USR side	Supply main clock signal from user system.
	EML side	Supply main clock signal from oscillator IC socket on adapter.
X0A,X1A	EML side	Supply sub clock signal from oscillator IC socket on adapter.

\* : There is no function to supply a clock signal from the adapter to the user system.

Note : To supply a main clock signal from the user system, prepare an oscillation circuit on the user system and use, for example, a CMOS buffer for buffering before the signal is supplied.

As supplying a subclock signal from the user system may result in unstable operation, be sure to supply the subclock signal from the adapter board.

### 5.3 Setting a Reset Signal

---

The reset signal is supplied to evaluation MCU from the user system or the emulator. Please use a setup at the time of product shipment of a jumper plug.

---

#### ■ Setting the Reset signal

A setup at the time of product shipment of a jumper plug is shown in Fig. 5.3-1. By this setup, the INITX signal ( $\overline{\text{INIT}}$ ) of evaluation MCU is supplied from the INITX signal of a user system via an emulator, and the TRSTX signal ( $\overline{\text{TRST}}$ ) of evaluation MCU is supplied from the reset signal of an emulator.

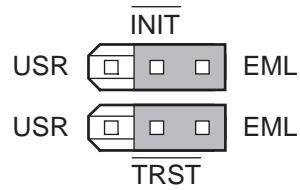

Figure 5.3-1 Setting the Reset Signal Setting Jumper Plugs (Factory Setting)

## 5.4 Setting a External Memory Emulation

Figure 5.4-1 shows the external memory emulation block diagram, figure 5.4-2 and table 5.4-1 show the setting the memory size select switch and the factory settings of the memory size select switch, figure 5.4-3 shows the factory settings of the setting the memory connective switches; Table 5.4-2 lists the memory connective switch settings.

### External Memory Emulation Block Diagram

Figure 5.4-1 shows the external memory emulation block diagram.

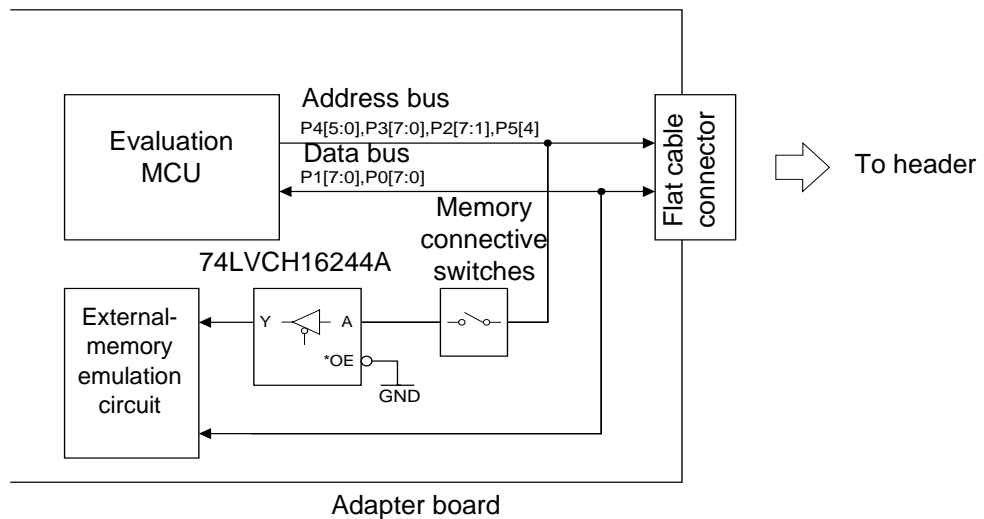

Figure 5.4-1 External Memory Emulation Block Diagram

### Setting the Memory Size Select Switch

The memory size select switch select the size of the memory board to be connected to use the external memory emulation function.

Figure 5.4-2 shows the factory settings of the switch; Table 5.4-1 lists the memory board sizes and effective addresses depending on the settings of the switch.

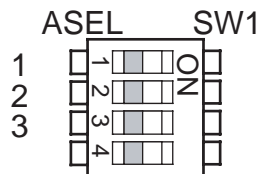

Figure 5.4-2 Setting the Memory Size Select Switch (Factory Setting)

Table 5.4-1 The Memory Size Select Switch Settings

ASEL3	ASEL2	ASEL1	Memory board size	Affective addresses
1	1	1	2 MWords	A[21:1]
1	1	0		
1	0	1	1 MWords	A[20:1]
1	0	0	512 KWords	A[19:1]
0	1	1	256 KWords	A[18:1]
0	1	0	128 KWords	A[17:1]
0	0	1	64 KWords	A[16:1]
0	0	0	32 KWords	A[15:1]

■ **Setting the Memory Connective Switches**

These switches can be used to disconnect address lines disabled by the memory capacity switching function from buffers and using them as user resources instead when the external-memory emulation function is used. Even when the external-memory emulation function is not used, the switches can be used to disconnect those address lines from buffers to reduce the load on the address lines used as user resources.

Figure 5.4-3 shows the factor settings of the switches; Table 5.4-2 lists the elements of the switches and their respective signal conductors and evaluation MCU's pin numbers.

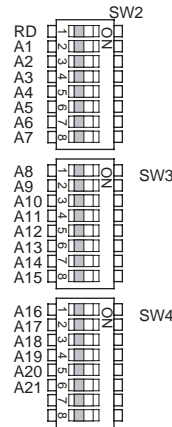

Figure 5.4-3 Setting the Memory Connective Switches (Factory Setting)

Table 5.4-2 The Memory Connective Switch Settings

Part number (Printed on board)	Element number (Labeled on switch)	Relevant signal conductor	Evaluation MCU's pin number
SW2	1	P54 (RDX)	140
	2	P21 (A1)	310
	3	P22 (A2)	201
	4	P23 (A3)	357
	5	P24 (A4)	257
	6	P25 (A5)	144
	7	P26 (A6)	309
	8	P27 (A7)	256
SW3	1	P30 (A8)	200
	2	P31 (A9)	356
	3	P32 (A10)	308
	4	P33 (A11)	92
	5	P34 (A12)	44
	6	P35 (A13)	255
	7	P36 (A14)	143
	8	P37 (A15)	199
SW4	1	P40 (A16)	307
	2	P41 (A17)	91
	3	P42 (A18)	142
	4	P43 (A19)	254
	5	P44 (A20)	43
	6	P45 (A21)	198

\*: The user resources corresponding to the above pin numbers are different depending on the evaluation MCU used.

For details, refer to the hardware manual for the evaluation MCU to be used or “APPENDIX User Interface Specifications”.

## 5.5 Power-on/Shutdown Procedures

Finish connecting all the components of your entire system, then turn them on in the order: host machine -> emulator -> user system.

Shut down your system by turning off the components in the order: user system -> emulator -> host machine.

### ■ Power-on Procedure

To turn the power on, finish making all the required connections and follow the procedure in Figure 5.5-1.

To turn on the emulator, press the power switch on the back of the emulator. The power switch remains depressed.

Check the position of the power switch with the hardware manual for the emulator.

Note : When turning on the individual components of your system, follow the power-on procedure specified in the manual.

Once you have turned the adapter on, do not carry it or apply shock or vibration to it.

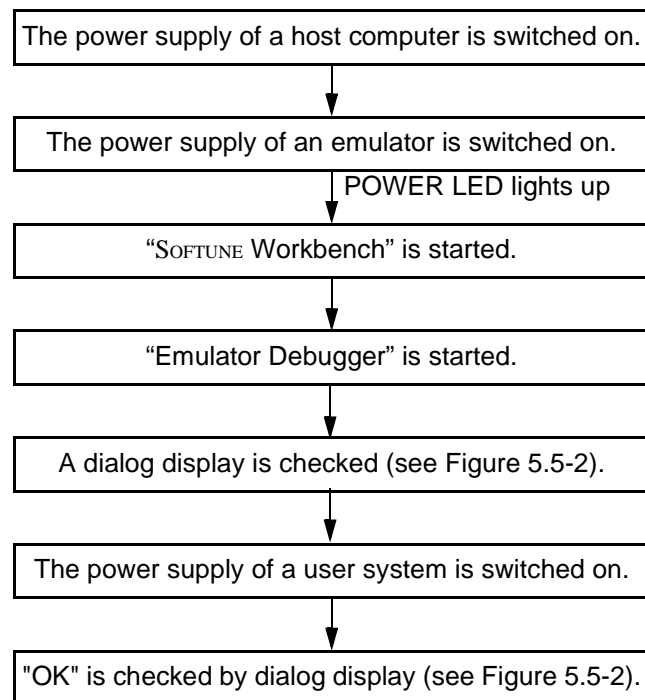

Figure 5.5-1 Power-on Procedure



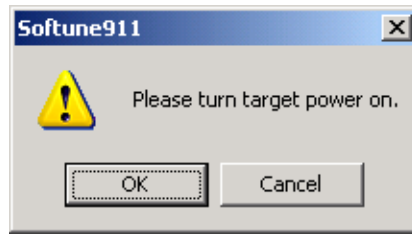

Figure 5.5-2 Dialog Display

■ **Shutdown Procedure**

To shut down your system, follow the procedure shown in Figure 5.5-3.

To turn off the emulator, press and release the power switch on the back of the emulator. This returns the depressed switch to the OFF (raised) state.

Check the position of the power switch with the hardware manual for the emulator.

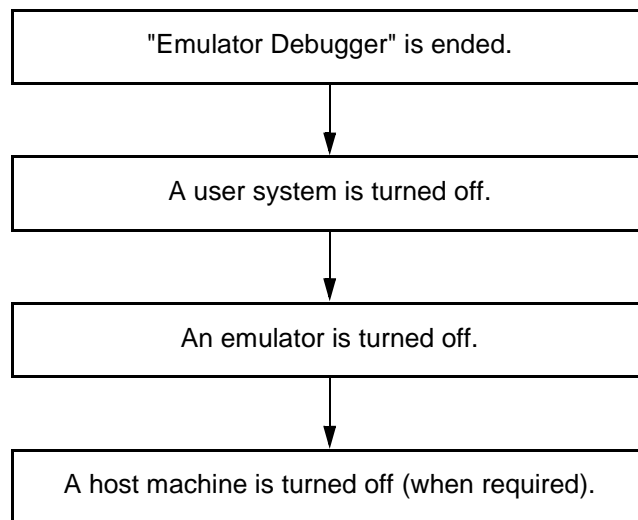

Figure 5.5-3 Shutdown Procedure

Note : When turning off the individual components of your system, follow the shutdown procedure specified in the manual.

## Chapter 6 Cautions

---

This chapter lists precautions and important notes on use of this product.

That extra cautions apply to the adapter when the external-emulation memory and power-on debug functions are used.

---

### ■ General Cautions on the Adapter

- Before setting a jumper plug or switch on the adapter board, turn off all of the adapter, emulator, and user system.
- The settings of jumper plugs VSEL1 to VSEL4 are related to power supply. Setting these jumper plugs incorrectly can destroy the entire system.
- When the user system supplies a clock signal to the evaluation MCU, the wiring pattern from the clock signal source on the user system side may be too long to provide oscillation.
- When the user system supply a clock signal to the evaluation MCU using an oscillator, the evaluation MCU has a restriction that, if the X0 or X1 pin must be opened, the jumper plug for selecting the corresponding clock signal source must be removed. This also applies to X0A and X1A.
- When the emulator is used, INITX pin control source of the evaluation MCU' to the emulator position set the jumper plug to a reset signal setting. When the emulator is being used, the evaluation MCU's INITX pin is controlled by the emulator and the reset signal from the user system is input to the evaluation MCU via the emulator. The reset timing is therefore delayed several clock cycles from the actual reset timing.  
The reset command of the emulator only resets the evaluation MCU; it does not reset the user system.  
In addition, the signal sent from the user system to the INITX pin during a break is masked by the emulator.
- The pin state of the user bus when the evaluation MCU is in the user hold/low power consumption mode is the same as the one stated in the Evaluation MCU hardware manual.
- The flat cable (long) can be used when the MCU's clock frequency is low or when the load on user pins is very light. Usually, the flat cable (standard) should be used.
- When the adapter and header are used, the MCU on the user system must always be socket mounted. The IC socket must be the designated IC socket.
- No power is supplied to the user system from the adapter, header, or emulator.
- When the external memory emulation function is not used, set all the memory connection switches to OFF. If external signals are applied with the memory connection switches set to ON, drive the adapter at a current of at least  $\pm 750\mu\text{A}$ . If the drive current is lower than  $\pm 750\mu\text{A}$ , a normal potential may not be obtained due to the bus hold feature of the buffer IC.

### ■ Cautions to be observed when the External Memory Emulation Function

- When external-memory emulation is used, set those memory connective switches to ON which correspond to the effective address bus signal (equivalent to A[21:1], variable with memory size setting) and control line (equivalent to RDX).
- A buffer IC is connected to the effective address bus signal (variable with the memory size setting) and control line used for external-memory emulation. A capacitance of about 6 pF is therefore added to each of the signal conductors.
- As a buffer IC is connected to the effective address bus signal and control line used for external-memory emulation, each signal conductor connected to the memory board involves a delay of about 6 ns.
- As the data bus used for external-memory emulation is connected directly to the data bus signal (equivalent to D[31:16]), the external I/O power supply to the evaluation MCU must always be +3.3 V. The external I/O power supply exceeding +3.3 V can break the memory board.
- As the data bus used for external-memory emulation is connected directly to the data bus of the evaluation MCU, a capacitance of about 6 pF is added to each signal conductor when the

memory board is installed.

- The data bus used for external-memory emulation is fixed at 16 bits in width.
- Although some of the address bus signals, data bus signals, and control lines of the memory board are connected to the user system, the chip select signal is not connected and thus the user system cannot access data in the memory board.

■ **Cautions to be observed when the Power-on Debug Function**

- When performing power-on debugging, pay due attention to the settings related to power supply.
- The following three conditions must be satisfied when the power supply is turned off by power-on debugging:
  1. It takes 25  $\mu$ s or more for all the power supply levels of the evaluation MCU to decrease from 0.9 Vcc to 0.5 Vcc.
  2. The CPU operating frequency is 1 MHz or higher.
  3. A user program is being executed.
- For details on the power-on debug function, refer to the emulator hardware manual.

■ **Cautions to be observed when the external memory emulation function and the Power-on Debug Function**

- If the user power supply remaining high level is shut off with the External address and RDX pins, the bus hold feature of the buffer ICs on the adapter board causes a current of up to 250 mA to flow until each signal level goes low.

# APPENDIX User Interface Specifications

This appendix describes the user interface specifications of the adapter board.

## ■ User Interface Specifications

Figure A-1 shows the correspondence between the pin numbers of flat cable connectors A and B of the adapter board and those of the header or user system. Table A-1 and table A-2 lists the pinouts of flat cable connectors A and B and the evaluation MCU.

Note that the evaluation MCU signal names in the table are tentative names and their actual signal names vary with each model. The actual evaluation MCU signal names can be judged from the evaluation MCU pin numbers. For details, Please ask, when unknown.

Each signal name of the evaluation MCU has the following meaning. See the notes that follow as well.

- Vcc\_A : Internal power supply of the evaluation MCU (or the C pin).
- Vcc\_B : I/O power supply of the evaluation MCU (or a single power supply).
- VCCXTL : Main clock power supply of the evaluation MCU.
- GND : Ground of the evaluation MCU.

Note : To the pins whose evaluation MCU signal name is underlined in the table, an additional circuit may be added for controlling the evaluation MCU. Therefore, those pins have different electrical characteristics from those on the actual MCU.

See the sections listed below for details on the additional circuit for each signal.

- P65/P85/PD3/PF2(DVcc) : See Section 4.5 "Installing a Bypass Capacitor for DVCC."
- X0/X1 : See Section 5.2 "Setup for Clock Supply."
- X0A/X1A(PF5/PF6) : See Section 5.2 "Setup for Clock Supply."
- P54(RDX) : See Section 5.4 "Setup for External-Memory Emulation."
- P4[5:0](A[21:16])
- P3[7:0](A[15:8])
- P2[7:1](A[7:1])
- P1[7:0](D[15:8])
- P0[7:0](D[7:0])

The emulator uses Vcc\_A and Vcc\_B mainly as the power supplies to the evaluation MCU and additionally for voltage detection purposes only; it does not contain circuit consuming large power.

It is advisable to use the flat cable (standard) bundled with the emulator to prevent noise trouble.

Provide the user system with a connector equivalent to the flat cable connector. The part number of the flat cable connector is as follows:

- Flat cable connector part number: 8930E-100-178MS (manufactured by KEL)

Notice that the pinouts of flat cable connectors A and B are different between the adapter board and the user system.

# APPENDIX User Interface Specifications

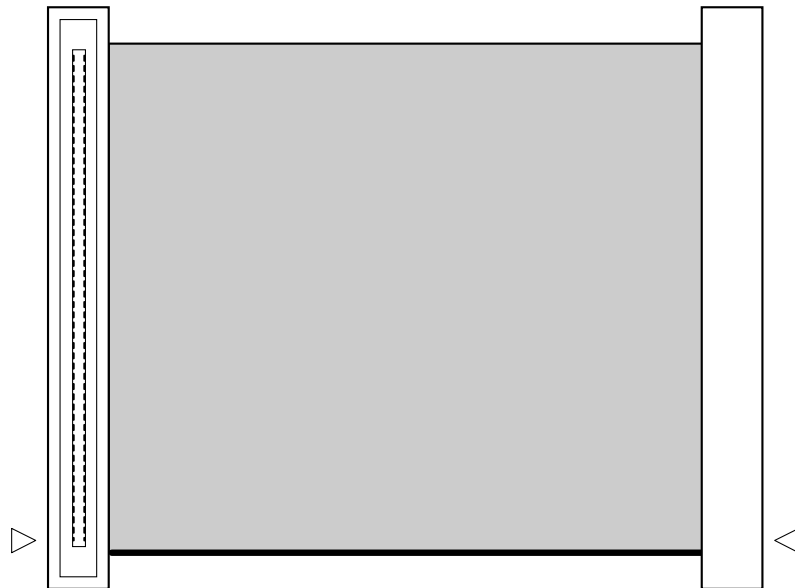
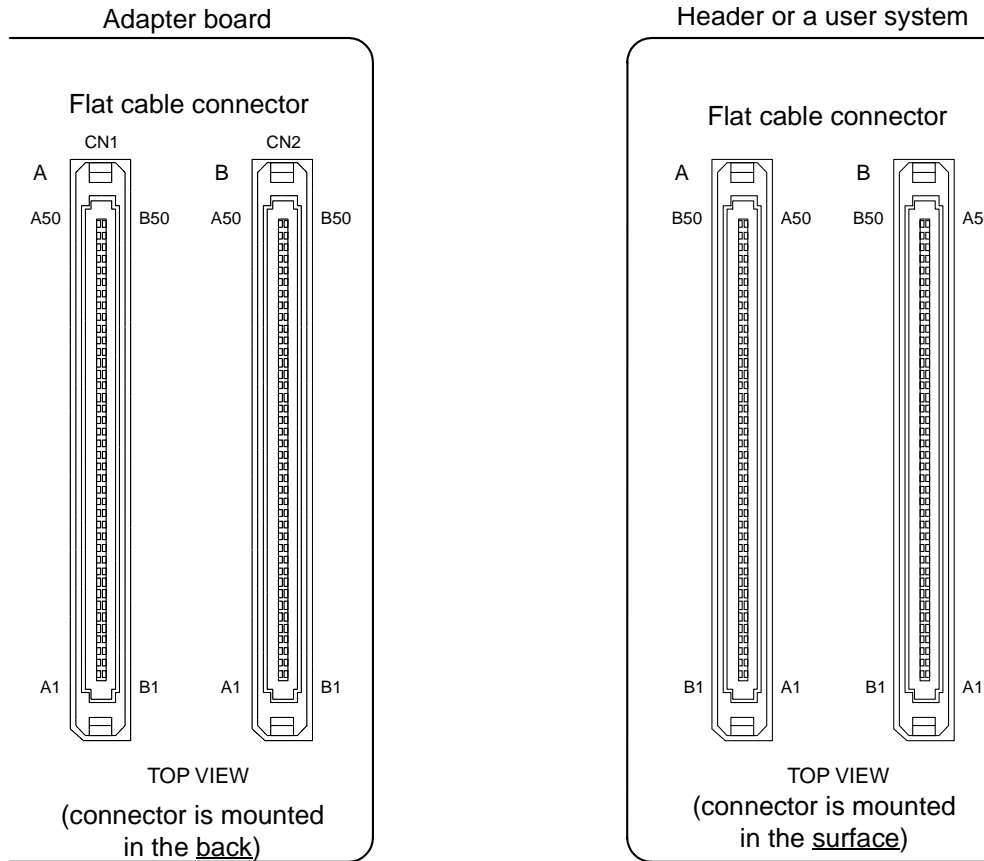

Figure A-1 Pin Numbers of Flat Cable Connectors A and B

# APPENDIX User Interface Specifications

Table A-1 Pinouts of Flat Cable Connector A

Connector pin number	Evaluation MCU signal name (temporary name)*	Evaluation MCU pin number	Connector pin number	Evaluation MCU signal name (temporary name)*	Evaluation MCU pin number
A1	GND	–	B1	GND	–
A2	P91	135	B2	P92	84
A3	P93	301	B3	P94	192
A4	P95	191	B4	P96	35
A5	P97	349	B5	AVCC	131
A6	AVRH	296	B6	AVRL	242
A7	AVSS	186	B7	PC0	245
A8	PC1	188	B8	PC2	297
A9	PC3	244	B9	PC4	346
A10	PC5	187	B10	PC6	345
A11	PC7	243	B11	GND	–
A12	PA0	83	B12	PA1	300
A13	Vcc_A	–	B13	PA2	248
A14	P87	249	B14	P90	193
A15	GND	–	B15	P86	85
A16	P84	302	B16	<u>P85(DVcc)</u>	36
A17	P82	136	B17	P83	303
A18	P80	37	B18	P81	86
A19	P77	138	B19	GND	–
A20	P75	250	B20	P76	351
A21	P73	195	B21	P74	137
A22	P71	38	B22	P72	194
A23	GND	–	B23	Vcc_A	–
A24	VCC3B	5	B24	P70	87
A25	<u>X0A/PF5</u>	209	B25	<u>X1A/PF6</u>	51
A26	P66	252	B26	P67	251
A27	<u>P65(DVcc)</u>	39	B27	GND	–
A28	P63	40	B28	P64	304
A29	P61	139	B29	P62	88
A30	P57	41	B30	P60	305
A31	GND	–	B31	P56	89
A32	<u>P54(RDX)</u>	140	B32	P55	196
A33	P52	42	B33	P53	253
A34	P51	306	B34	Vcc_A	–
A35	P50	197	B35	GND	–
A36	P46	141	B36	P47	90
A37	VCCXTL	76	B37	P20	202
A38	<u>P21(A1)</u>	310	B38	<u>P22(A2)</u>	201
A39	GND	–	B39	<u>P23(A3)</u>	357
A40	<u>P24(A4)</u>	257	B40	<u>P25(A5)</u>	144
A41	<u>P26(A6)</u>	309	B41	<u>P27(A7)</u>	256
A42	<u>P30(A8)</u>	200	B42	<u>P31(A9)</u>	356
A43	<u>P32(A10)</u>	308	B43	GND	–
A44	<u>P33(A11)</u>	92	B44	<u>P34(A12)</u>	44
A45	<u>P35(A13)</u>	255	B45	<u>P36(A14)</u>	143
A46	<u>P37(A15)</u>	199	B46	<u>P40(A16)</u>	307
A47	<u>P41(A17)</u>	91	B47	Vcc_A	–
A48	<u>P43(A19)</u>	254	B48	<u>P42(A18)</u>	142
A49	<u>P45(A21)</u>	198	B49	<u>P44(A20)</u>	43
A50	GND	–	B50	GND	–

\*:The evaluation MCU signal name of table A-1 should keep in mind that actual signal names differ for every kind for a "temporary name".

# APPENDIX User Interface Specifications

Table A-2 Pinouts of Flat Cable Connector B

Connector pin number	Evaluation MCU signal name (temporary name)*	Evaluation MCU pin number	Connector pin number	Evaluation MCU signal name (temporary name)*	Evaluation MCU pin number
A1	GND	–	B1	GND	–
A2	–	–	B2	PG5	50
A3	PG4	4	B3	PG3	315
A4	PG2	208	B4	PG1	98
A5	PG0	153	B5	PF3	182
A6	<u>PF2(DV<sub>cc</sub>)</u>	127	B6	PF1	239
A7	GND	–	B7	PF0	31
A8	PE7	293	B8	PE6	183
A9	PE5	78	B9	PE4	128
A10	PE3	184	B10	PE2	32
A11	PE1	240	B11	GND	–
A12	PE0	129	B12	PD7	79
A13	PD6	294	B13	PD5	185
A14	PD4	130	B14	<u>PD3(DV<sub>cc</sub>)</u>	241
A15	GND	–	B15	PG6	97
A16	PD2	80	B16	PD1	295
A17	V <sub>cc</sub> _B	–	B17	PD0	344
A18	PB7	298	B18	PB6	132
A19	PB5	189	B19	GND	–
A20	PB4	246	B20	PB3	348
A21	PB2	299	B21	PB1	133
A22	PB0	81	B22	VCC3IO	33
A23	GND	–	B23	PA7	247
A24	PA6	190	B24	PA5	34
A25	PA4	134	B25	PA3	82
A26	V <sub>cc</sub> _B	–	B26	<u>X0</u>	29
A27	<u>X1</u>	291	B27	GND	–
A28	<u>P17(D15)</u>	258	B28	<u>P16(D14)</u>	146
A29	<u>P15(D13)</u>	203	B29	<u>P14(D12)</u>	259
A30	<u>P13(D11)</u>	93	B30	<u>P12(D10)</u>	147
A31	GND	–	B31	<u>P11(D9)</u>	204
A32	<u>P10(D8)</u>	312	B32	<u>P07(D7)</u>	260
A33	<u>P06(D6)</u>	94	B33	<u>P05(D5)</u>	45
A34	<u>P04(D4)</u>	205	B34	<u>P03(D3)</u>	148
A35	<u>P02(D2)</u>	1	B35	GND	–
A36	V <sub>cc</sub> _B	–	B36	<u>P01(D1)</u>	95
A37	<u>P00(D0)</u>	46	B37	INITX	126
A38	MOD0	292	B38	MOD1	30
A39	GND	–	B39	MOD2	77
A40	PI7	206	B40	PI6	261
A41	PI5	47	B41	PI4	313
A42	PI3	2	B42	PI2	149
A43	PI1	150	B43	GND	–
A44	PI0	262	B44	PH7	48
A45	PH6	96	B45	PH5	151
A46	PH4	207	B46	PH3	49
A47	GND	–	B47	PH2	3
A48	PH1	263	B48	V <sub>cc</sub> _B	–
A49	PH0	264	B49	–	–
A50	GND	–	B50	GND	–

\*:The evaluation MCU signal name of table A-2 should keep in mind that actual signal names differ for every kind for a "temporary name".

SS01-71047-1E

---

**FUJITSU SEMICONDUCTOR • SUPPORT SYSTEM**

DSU-FR emulator  
PGA-401P adapter Type2  
MB2198-130  
Operation Manual

---

January 2005 the first edition

Published **FUJITSU LIMITED** Electronic Devices

Edited Business Promotion Dept.

---



**FUJITSU**

## Free Manuals Download Website

<http://myh66.com>

<http://usermanuals.us>

<http://www.somanuals.com>

<http://www.4manuals.cc>

<http://www.manual-lib.com>

<http://www.404manual.com>

<http://www.luxmanual.com>

<http://aubethermostatmanual.com>

Golf course search by state

<http://golfingnear.com>

Email search by domain

<http://emailbydomain.com>

Auto manuals search

<http://auto.somanuals.com>

TV manuals search

<http://tv.somanuals.com>