

MB91360 SERIES EVALUATION BOARD STARTERKIT MB91360

USER GUIDE

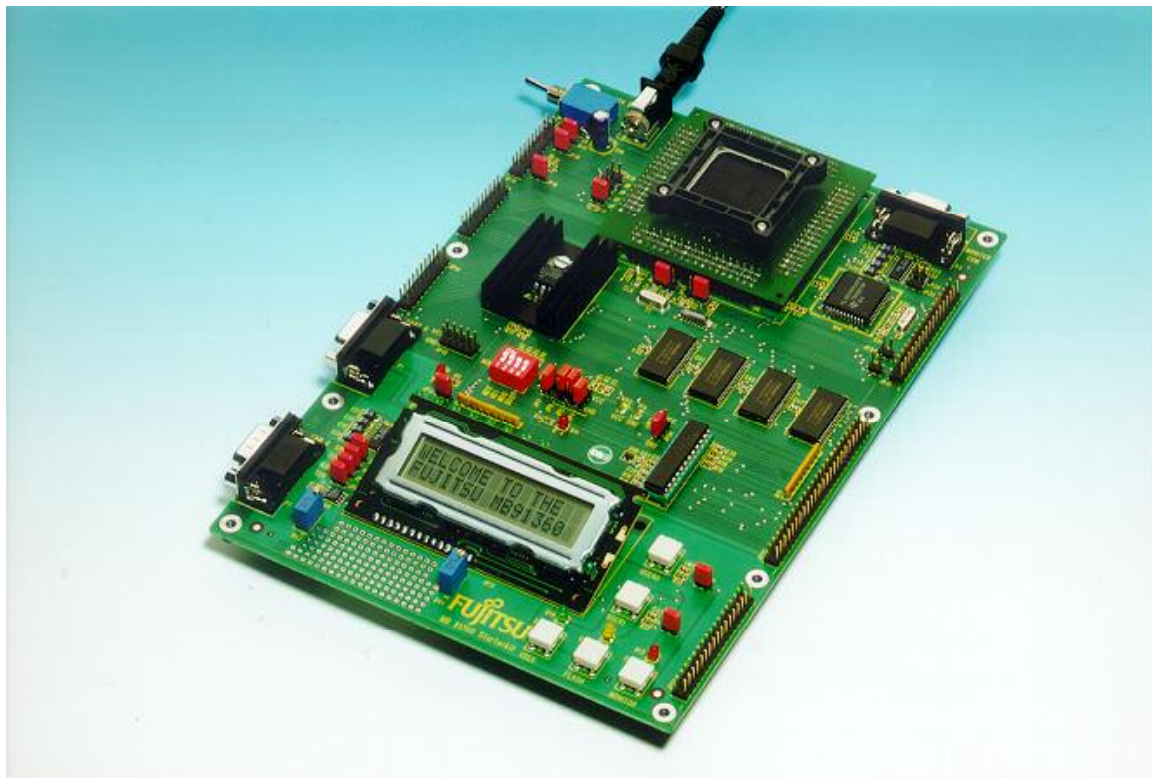

Revision History

Date	Issue
1999	1.0 MM First draft
2001	1.2 MM
09 July 2003	V1.3, MSt new format, Info about MB91F361 removed

This document contains 43 pages.

Warranty and Disclaimer

To the maximum extent permitted by applicable law, Fujitsu Microelectronics Europe GmbH restricts its warranties and its liability for **STARTERKIT MB91360 and all its deliverables** (eg. software include or header files, application examples, target boards, evaluation boards, engineering samples of IC's etc.), its performance and any consequential damages, on the use of the Product in accordance with (i) the terms of the License Agreement and the Sale and Purchase Agreement under which agreements the Product has been delivered, (ii) the technical descriptions and (iii) all accompanying written materials. In addition, to the maximum extent permitted by applicable law, Fujitsu Microelectronics Europe GmbH disclaims all warranties and liabilities for the performance of the Product and any consequential damages in cases of unauthorised decompiling and/or reverse engineering and/or disassembling. **Note, the STARTERKIT MB91360 and all its deliverables are intended and must only be used in an evaluation laboratory environment.**

1. Fujitsu Microelectronics Europe GmbH warrants that the Product will perform substantially in accordance with the accompanying written materials for a period of 90 days from the date of receipt by the customer. Concerning the hardware components of the Product, Fujitsu Microelectronics Europe GmbH warrants that the Product will be free from defects in material and workmanship under use and service as specified in the accompanying written materials for a duration of 1 year from the date of receipt by the customer.
2. Should a Product turn out to be defect, Fujitsu Microelectronics Europe GmbH's entire liability and the customer's exclusive remedy shall be, at Fujitsu Microelectronics Europe GmbH's sole discretion, either return of the purchase price and the license fee, or replacement of the Product or parts thereof, if the Product is returned to Fujitsu Microelectronics Europe GmbH in original packing and without further defects resulting from the customer's use or the transport. However, this warranty is excluded if the defect has resulted from an accident not attributable to Fujitsu Microelectronics Europe GmbH, or abuse or misapplication attributable to the customer or any other third party not relating to Fujitsu Microelectronics Europe GmbH.
3. To the maximum extent permitted by applicable law Fujitsu Microelectronics Europe GmbH disclaims all other warranties, whether expressed or implied, in particular, but not limited to, warranties of merchantability and fitness for a particular purpose for which the Product is not designated.
4. To the maximum extent permitted by applicable law, Fujitsu Microelectronics Europe GmbH's and its suppliers' liability is restricted to intention and gross negligence.

NO LIABILITY FOR CONSEQUENTIAL DAMAGES

To the maximum extent permitted by applicable law, in no event shall Fujitsu Microelectronics Europe GmbH and its suppliers be liable for any damages whatsoever (including but without limitation, consequential and/or indirect damages for personal injury, assets of substantial value, loss of profits, interruption of business operation, loss of information, or any other monetary or pecuniary loss) arising from the use of the Product.

Should one of the above stipulations be or become invalid and/or unenforceable, the remaining stipulations shall stay in full effect

Contents

REVISION HISTORY	2
WARRANTY AND DISCLAIMER	3
CONTENTS	4
1 INTRODUCTION	6
1.1 Abstract.....	6
1.2 Key Features.....	6
1.3 General Board Usage.....	7
1.4 Mode Selection	8
2 INSTALLATION	9
2.1 Hardware Installation.....	9
2.2 Software Installation	10
3 GETTING STARTED.....	11
3.1 Softune Workbench Development Introduction.....	11
3.2 Softune Workbench Debugging Introduction	13
4 DETAILS OF THE INCLUDED MONITOR-DEBUGGER.....	15
4.1 Basic debugger features.....	15
4.2 Advanced debugger features.....	17
5 FLASH PROGRAMMING.....	20
5.1 Generic Flash Programmer	20
6 EVALUATION BOARD HARDWARE	22
6.1 Board Components	22
6.2 Overview of Jumpers.....	23
6.3 Connectors for resources and IO-signals.....	25
7 APPENDIX.....	29
7.1 Memory Mappings MB91F362.....	29
7.1.1 MODE 000 (Single-Chip / Monitor Mode).....	29
7.1.2 MODE 001 (External Bus / User Mode)	30
7.2 Tool options for own projects.....	31
7.3 Starterkit limitations	32
7.4 Board Schematics	33
7.5 Silk Screen	36
7.6 PAL Listing	37

7.7 Development tools and accessories	39
7.8 Related Documents	40
7.9 Trouble Shooting	41
7.10 Figures	43
7.11 Tables	43

1 Introduction

1.1 Abstract

The Fujitsu MB91360 evaluation board is a stand-alone application board that makes it easy to evaluate and demonstrate almost all features of the MB91360 microcontroller series. Along with the supplied Windows-based development tools, it can be used as a system for user program developments.

The board can be configured as a target for the MB91360 emulation-system or as a stand-alone evaluation unit. When using the system in stand-alone mode, a monitor debugger is available to allow high-level debugging using Softune Workbench.

All peripheral functions are available on external pin-headers in order to design and test user applications cost- and time-effectively. For some resource functions, additional hardware is already present on the board (e.g. CAN- and UART-transceivers, LEDs, Buttons, etc).

The included Windows-based Software “Softune Workbench” is an integrated front-end for development and debugging. It allows fast development of “ANSI C”-based applications for the evaluationboard. To get started quickly, a number of example projects and templates are available.

Related documents such as “MB91360 Hardware Manual” are available and should always be used in addition to this manual (see appendix).

1.2 Key Features

- ▶ Footprint QFP208 (0.5mm pitch) + socket for MB91F362 (or emulation socket), surrounded by headers for test-pins etc.
- ▶ 4MHz and 32kHz crystal
- ▶ DC Power-supply circuit (incl. testpins for Vcc, GND, LED and switch)
- ▶ 512kB external SRAM available for user code and data
- ▶ External 16550 UART (supports transfer-rates up to 115.2 kBaud)
- ▶ 22V10-PAL for various control functions
- ▶ Resets (“Monitor”=Start monitor mode, “User”=exec user program from external RAM, “Flash”=exec user program from flash-ROM)
- ▶ MAX232 + DB9 (female) connectors for monitor and internal UART
- ▶ CAN transceiver and DB9 (male) for internal CAN0
- ▶ External Interrupt 0 and 1 connected to buttons for user interaction
- ▶ Various jumpers for individual configuration
- ▶ 2x16 char LCD (on Port G)
- ▶ 8 LEDs (on Port J)
- ▶ External bus and all resources logically grouped on pin-headers

- ▶ Area for extensions (2.54mm grid)
- ▶ Standard Euro-format (16x20 cm)
- ▶ Built-in monitor debugger (in Flash)
- ▶ Software includes Softune Workbench, a set of tools (e.g. flashloader) and example projects.

1.3 General Board Usage

The MB91360 Starterkit can be used as stand-alone evaluation board or as a target system for the MB2197-01 In-Circuit-Emulator.

To use the board as stand-alone evaluation board, a pre-programmed flash device (MB91F362 with monitor software) must be present inside the QFP-208 socket. The chip will use the built-in monitor to handle communication with the PC and makes use of the 512k SRAM onboard as program-memory for user's application. This manual explains how to use the MB91360 Starterkit as a stand-alone evaluation board.

To use the board as target for the In-Circuit-Emulator, unscrew the socket and remove the MB91F362 from the socket. Be careful not to bend any pins of the chip! Using a vacuum chip-handler is highly recommended.

Then mount the emulator probe-cable on top of the QFP-socket. Use the provided screws and make sure the cable has the right orientation. Follow the emulator set-up manual on the CD-ROM for any further steps.



Figure 1: Using the Starterkit as target board for the ICE

1.4 Mode Selection

The board has three different “modes”, which are represented by the three reset-buttons “USER”, “FLASH” and “MONITOR”.

By default, the board will startup in the “MONITOR”-mode, which automatically invokes the debugger kernel. The board now can communicate with Softune Workbench. This means, any application can be downloaded and debugged with all provided features such as breakpoints, watches, single step etc. (see chapter “Softune Debugging Features”).

Once any code has been downloaded to SRAM, the application can also be executed directly from a “USER” reset. The application will run without any intervention from the host (e.g. breakpoints). This mode should mainly be used to test the application before programming the entire contents to flash.

If finally the application has been transferred to flash-ROM, execution can start from the flash-ROM using the “FLASH”-reset. This is the stand-alone mode for any user application. As a last step, the board can be configured to start directly in the “FLASH”-mode after power-on (by jumper JP34). This allows creating of a “real” stand-alone application.

2 Installation

2.1 Hardware Installation

What you'll need :

- ▶ Host : IBM(-comp) PC with Windows 9x or Windows NT ; 1 COM-port
- ▶ Power Requirements: A power supply, capable of supporting 9-12V DC at about 500 mA. Note that the power connector must be + at the shield and - in the centre. Power supplies are available from Fujitsu.
- ▶ RS232 : An 'extension' (1:1) RS232 cable with DB9 m+f connectors

Connect the power-supply (9-12V DC-input) and the RS232-cable

and switch on the Starterkit.

LED D10 should light up (power-indicator)

and LED D11 flashing (reset indicator).

During the initialization phase
the red monitor LED is on.

After that, a start message from the monitor

("91360-STARTERKIT MONITOR VxLx")

will be displayed on the LCD and the green user LED will light up.

The board is now ready to use.

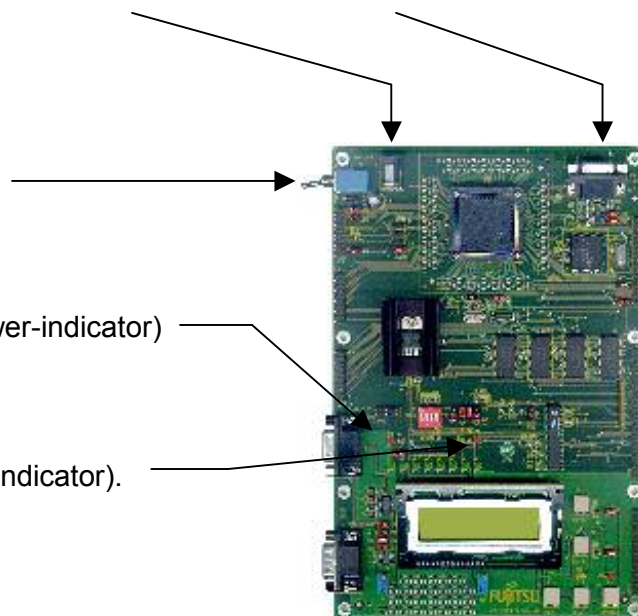

2.2 Software Installation

Insert the provided CD-ROM, browse to the installation page and select the Installation option for Softune Workbench. Follow the instructions to unpack and install Softune Workbench for FR ,as well as some example projects and additional tools for the MB91360 Starterkit. It is recommended to use the default installation path C:\Softune.

After the installation, you will find all language tools, the IDE and other system files within the directory Softune\Bin. Samples for the Starterkit can be found in the \smp\FR directory. The \tools directory contains additional software tools (flashloader etc.).

Execute "FR Family Softune Workbench" from your Start-Menu.

If any errors occur during installation, remove any previous versions of Softune Workbench from your PC and retry. Make sure you have enough disk space available and you have a supported Windows OS installed. For more information see the provided installation information and last-minute information.

Refer to the getting started session (next chapter) for more details on how to use Softune Workbench for developing and debugging.

3 Getting Started

Make sure you have Softune Workbench for FR installed on your PC and the evaluation board is ready to use. For details refer to the Hardware and Software Installation chapters. This chapter uses the available examples to illustrate some features of Softune Workbench.

3.1 Softune Workbench Development Introduction

Start Softune Workbench. Select “File – Open Project” to load the first example “LEDdemo1.Prj”. In the project tree on the left side, you can open the “source”-folder which contains the source-files registered to this project. A double-click on one of the files will invoke the built-in editor, which supports syntax-highlighting, tags and various other functions.

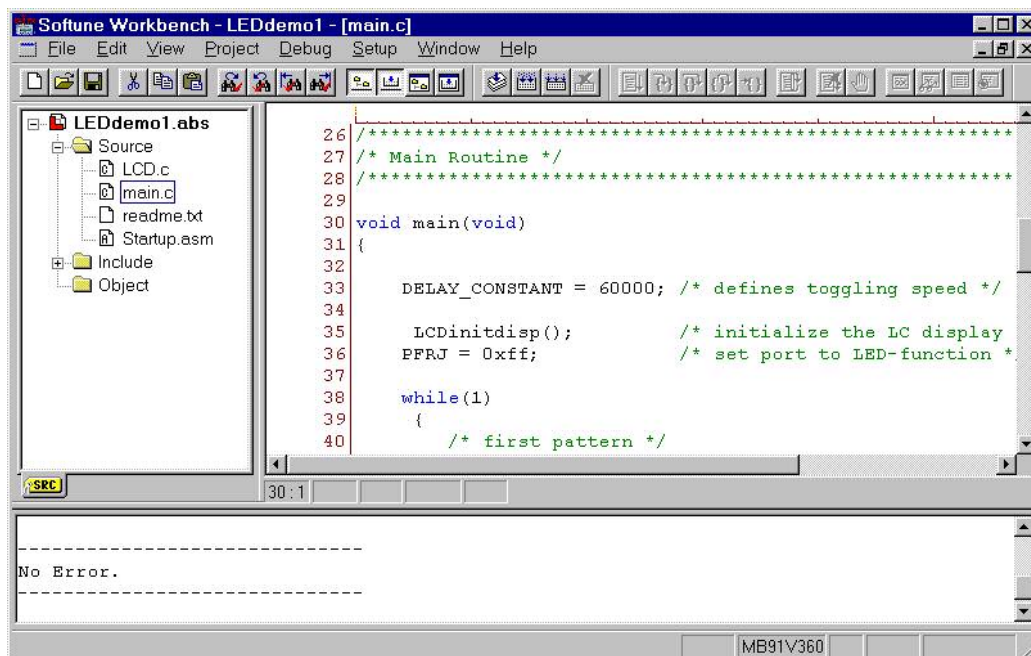

Figure 2: Softune Workbench Editor

① You may customize the editor by a right-click on the editor window.

Whenever you make changes to your source-files, you have to re-compile and link the related files to produce a valid loadmodule (ABS-file). This is done using the MAKE-function. MAKE invokes the assembler, C-compiler and linker for FR whenever necessary (only the changed files will be re-compiled).

If you wish to re-compile the entire project regardless of any changes, you can use the BUILD-function. To check for syntax-errors on a specific source-file, use the COMPILE/ASSEMBLE function.

These three functions are available on the button-bar or from the main menu (Project – Compile / Make / Build / Abort).

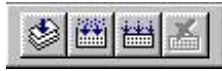

Click on MAKE or BUILD. Messages from the individual language tools will be fed into the output window at the bottom of the main screen. If the tool chain (C-compiler → Assembler → Linker) was completed successfully, the message “No Error” will appear.

If you get any errors during compilation, an appropriate message will be generated. Try this with a simple syntax-error (e.g. delete a semicolon “;” from the end of a C-line) and click on MAKE again. You will now see a message like this:

```
Now Making...
main.c
*** c:\softune\sample\..\leddemo1\src\main.c(43) E4062C: syntax error near `for'
```

```
-----
Error detected.
-----
```

To locate the position in the source-file, where the error has occurred, double-click on the message. The editor will open the appropriate source-file, indicating the error highlighted in red, depending on the customise settings of the editor. Correct the error and re-compile the project as explained above.

If more errors occurred, you can go through the error list step by step using the menu “Edit – Top/Previous/Next/Bottom Error” or using the appropriate buttons which have the same functions:



- ① To get on-line help about a specific error, select the error message and press F1. In many cases, you can get some useful hints how to solve the problem. Of course, you can also use the HELP-menu anytime during development or debugging.

3.2 Softune Workbench Debugging Introduction

Whenever you have successfully created a valid load module, you may switch from the development mode to the debugging mode of Softune Workbench.

Basically, there are 3 types of debugging systems supported :

1. The software simulator: This type of debugger is always present and does not require any special hardware extensions. The simulator will cover the FR-core features, but no peripheral functions. Therefore, you can use the simulator to verify program flow, check for dynamic errors, look at the generated assembler code and so on.
2. The monitor debugger: This debugger type requires an evaluation board like the MB91360 Starterkit connected to one of the COM-ports of your PC. Therefore, make sure you have the evaluation board connected and powered-up as described before. Explanations in this manual refer to the monitor debugger only.
3. The emulator debugger: The in-circuit-emulator (ICE) is a system, which allows a connection to any target system using a probe-cable. The appropriate system for the MB91360 series is the MB2197-01 system. More information about this system can be found on the Fujitsu Micros CD-ROM or on our website.

Which debugger is used for the actual project can be configured in the “Project – Setup – Debug” menu:

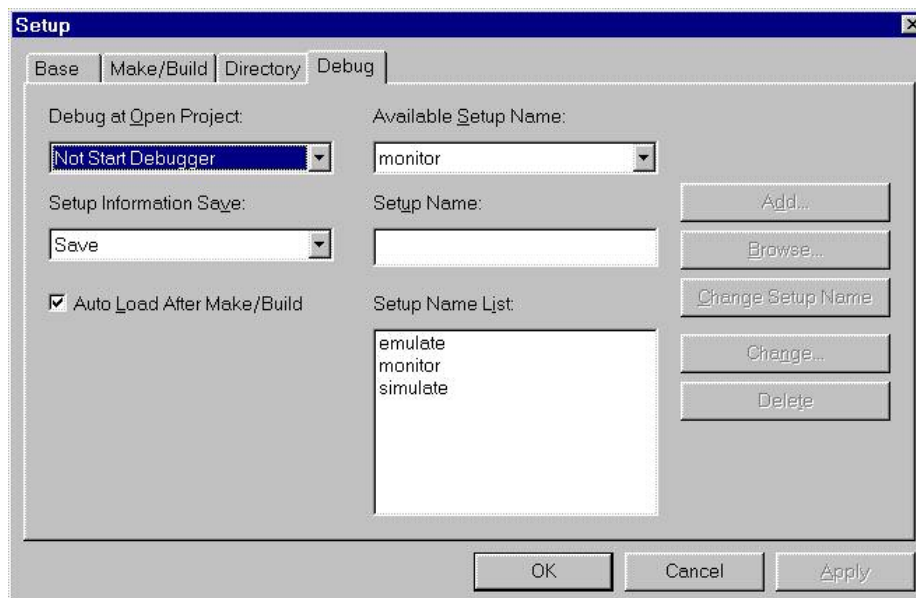

Always verify the settings before you start debugging a new project ! The current “setup” is indicated by the selected item in the “Available Setup Name” dropdown-box. The provided examples contain 3 setups (simulate, emulate and monitor). Ensure “monitor” is selected.

Click on “monitor” in the “Setup Name List” and click “Change”. A debug setup wizard will appear to guide you through the possible settings.

Make sure you are using the right COM-port number and Baudrate !

The default-settings for the monitor-debugger are fixed to :

COM-Port1 and 38400 Baud. Change the settings if necessary.

If these settings are correct, start the debugger using “Debug – Start Debug”. You should see a progress bar indicating the download process.

If nothing happens, there will be an error message after some time (“Invalid communication status”). Double-check the settings again as explained above. Also make sure the evaluation-board is powered on, ready to use and the RS232-cable is connected properly. Also see the trouble-shooting section in the appendix.

After starting the debugger, additional windows will appear which contain locate-arrows for each (possible) source-line, the original source-code,

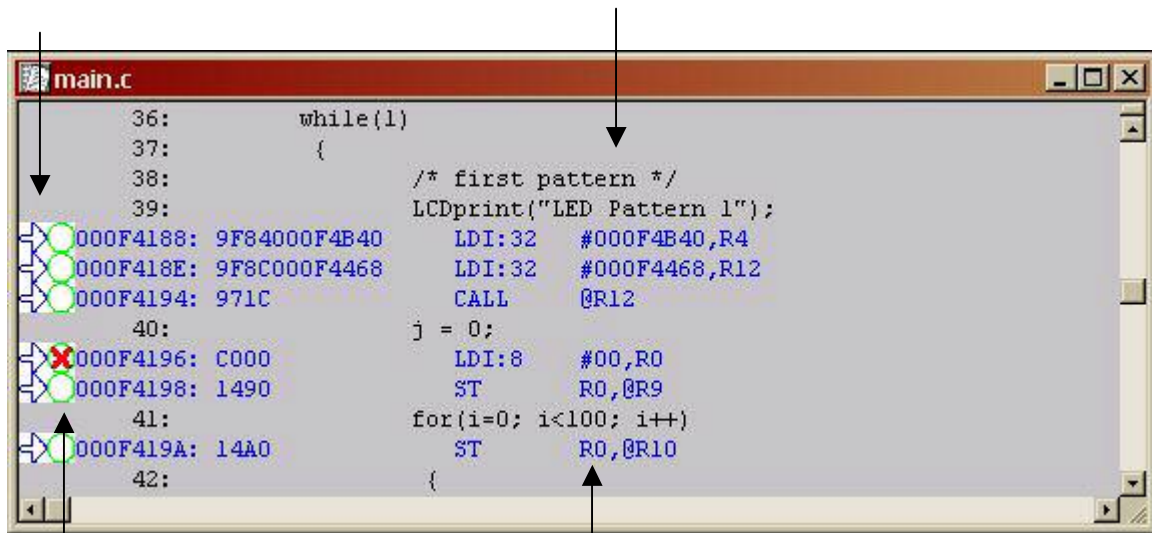

Figure 3: SWB Debugging window

breakpoint-indicators and the assembler code (in “mixed view”). The actual program position will be indicated by a yellow line.

① You can choose “mixed view” from the context menu (right-click) to display source and assembly code at the same time. To easily locate the actual line, use “go to current” !

4 Details of the included Monitor-Debugger

4.1 Basic debugger features



GO: Executes the program continuously from the memory location pointed to by the current program counter (PC) until a termination factor occurs.



STEP IN: Executes the program stepwise according to the listing in the source window (steps in C- or ASM). Note that Interrupts are disabled during step execution !



STEP OVER: Executes the program stepwise except call-instructions (which will be executed until return). Interrupts are not disabled during a continuous CALL...RETURN execution.



STEP OUT: Executes the program continuously to the parent function (until RETURN). Interrupts are enabled. Note, that debug information is required for this function.



EXECUTE UNTIL CURSOR: Automatically sets a breakpoint at the actual cursor position and executes continuously until this breakpoint, which will be deleted afterwards.

Each valid code line in a debugger window automatically has a locator (blue arrow) and a breakpoint-option (circle). Note that some C-lines may not be displayed with locators and breakpoints, because the compiler has created "optimized" assembler-code. Select "mixed view" in order to check the compiler output.

Instead of single-steps, you may also use the arrows to directly execute your program until a certain line of your source-code :

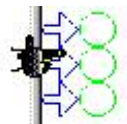



ABORT: Forcibly terminates execution.

CAUTION: This function can be used in single code line operations only
(example: `for(k=DELAY_CONSTANT; k>0; k--);`) !!



To abort continuous execution on the Starterkit, you have to use an external interrupt. All examples provided use the „USER0“-button for this purpose. If you wish to use the „USER0“-button for *Abort*, make sure you have the ABORT-option in `STARTUP.ASM` enabled :



```
#define ABORT 1
```

- ① The USER0-button is an external interrupt source which will be initialized at the highest priority. In the interrupt service routine (located in `STARTUP.ASM`) you will find a software trap (`INTE`), which will force the debugger to stop at this specific point. You may use traps also to intentionally stop in your code for debugging purposes.

4.2 Advanced debugger features



TOGGLE BREAKPOINT: Sets or deletes breakpoint at the current source line or :

To set or delete a breakpoint, click the circles at the beginning of a source-line. A  indicates an active breakpoint. Hit "go"  to execute until this line. A list  of all breakpoints can be found under the "Debug – Breakpoint" menu. 255 Software-Breakpoints (using TRAP replacement) are possible.

- ① To set breakpoints at positions which are currently not visible (e.g. because the source-window of that module is not open), you can also enter a symbolic label directly in the "Breakpoint" menu. Example: Enter "main" in the address-field and confirm. The new breakpoint will automatically be assigned to the address of the "main()" -function.



REGISTER WINDOW: Displays the CPU-register window. Updated registers appear in red. *Setup* in context menu defines which Registers should be displayed.



WATCH WINDOW: Displays the current variables to „watch“. Double-click on any variable in your code then specify *watch* in context menu to add to watch window. All listed variables in a watch window can be displayed in any number format. Use *Edit* to directly change the contents.

Example: Open the Leddemo1-Project and execute until you see the first LED-pattern. Then double-click on PDRJ in the debugger-window and select „watch“ in the context-menu. The watch-window will appear and PDRJ will be added to any existing variables. Select PDRJ in the watch window and choose „Edit“. Enter any value and confirm. You will now see the (8-Bit) value displayed on the LEDs directly as binary code. This is because PDRJ is the output latch of the LED-port (J).



MEMORY WINDOW: Displays memory areas in various formats defined by *Setup* (context menu). Changing of address/data is possible when debugger is not executing.

Note : If you make changes to the ROM-area (080000..0FFFFFF) it can affect the currently loaded program !



DISASSEMBLER: Disassembles the contents of the code memory beginning from actual PC position and displays the result in a separate window. Individual assembler-lines can be changed using the „inline assemble“-function.

DEBUG - STACK: Displays the current stack contents in terms of function calls. Parameters, if any, are given in brackets.

DEBUG - VECTOR: Reads out and displays the actual interrupt-vector table. Use the „jump“ function to display any code areas pointed to by an interrupt vector (e.g. interrupt service routines used in your program).

DEBUG - CALL: This function can be used to „call“ any routine defined in your code when the debugger is halted.

Example: Enter „LCDprintheX(0x1234,4)“ from any example project. The number 1234 will appear on the LCD. The function-call will be terminated by showing the result (here : none). You may restore the debugging context by „Clear call“ if execution was stopped during the function-call. Note that this example assumes that „LCDinitdisp“ was executed before.

DEBUG – LOAD TARGET FILE: Starts a new download of the current load module (ABS file). Usually this function will be executed automatically after starting the debugger (defined in debug settings ; see „Project-Setup-Debug“). However, this function can be useful to re-initialize the debugger for the current debug session.

VIEW - SYMBOL: This function displays all (global) symbols of the current project. Information about the type (char, integer etc.) and the location (address in RAM or register) can be shown using „detail“.

VIEW - LOCAL: Similar to View-Symbol, but only local variables of the current function are shown.

VIEW - COMMAND: From this window, the debugger can be controlled using a command line input. All GUI functions are available as individual commands.

Examples :

```
go
step
examine PDRJ
set break main
Dump/Halfword 100000..1000ff
```

Shortcuts to complex commands can be defined (“alias”) and parameter strings can be substituted by variables.

Example: `candump = Dump/Halfword 100000..1000ff`

A set of commands can be combined to a “macro”. Aliases and macros can be defined using the command window context menu.

Example: restart: set register PC=1f4000
 set break main

 go

In order to document or save debugging details such as memory contents, all outputs fed to the command console can be written to a file ("logging").

A whole "program" of commands (incl. flow control) can be written to a PRC-file and executed. Procedure-files are simple text-files with the extension ".PRC" and can be created by the Softune Workbench editor or any other text editor. To execute a procedure-file, use the command window menu or the "file-open" menu during debugging.

- ① Procedure-files can be very helpful to automatically configure the debug-environment, perform automated tests (e.g. when a new C-module has to be tested) or to enhance basic emulator functions such as breakpoints. Using a procedure file, breakpoints can be dynamically defined depending on program conditions. See the "Command Reference Manual" (on-line help) for detailed information about the available command and parameter syntax.

5 Flash Programming

Whenever your application has been developed, debugged and tested as explained in the last chapter, it can be programmed to the internal flash ROM using the „MB91360 Flash Programmer“. This tool is a general flash programming utility, which allows programming the internal flash ROM without any restrictions given by the starterkit.

5.1 Generic Flash Programmer

The tool „MB91360 Flash Programmer“ is a general flash programming tool which does not take care of the special features of this Starterkit. Therefore, it should be used to re-program the monitor-kernel. On the CD-ROM, you will find some kernel files (MHX-format) which are fixed for various baud rates. Make sure, you have the latest version available!

The tool can also be used to program any applications directly (without the possibility to have any debugging functions later on). In this case, the evaluation board will act as a target system only.

CAUTION: Take special care not to write anything to location 0FFEF4, the „security vector“. If you do, you will not be able to re-program the device ever again! See the hardware manual for details!

Make sure you have installed the Flash Programmer from your CD-ROM. The package includes the executable (Flashprg.exe) as well as some binary files (Brloadxx.bin) and a user's guide (Flashprg.pdf).

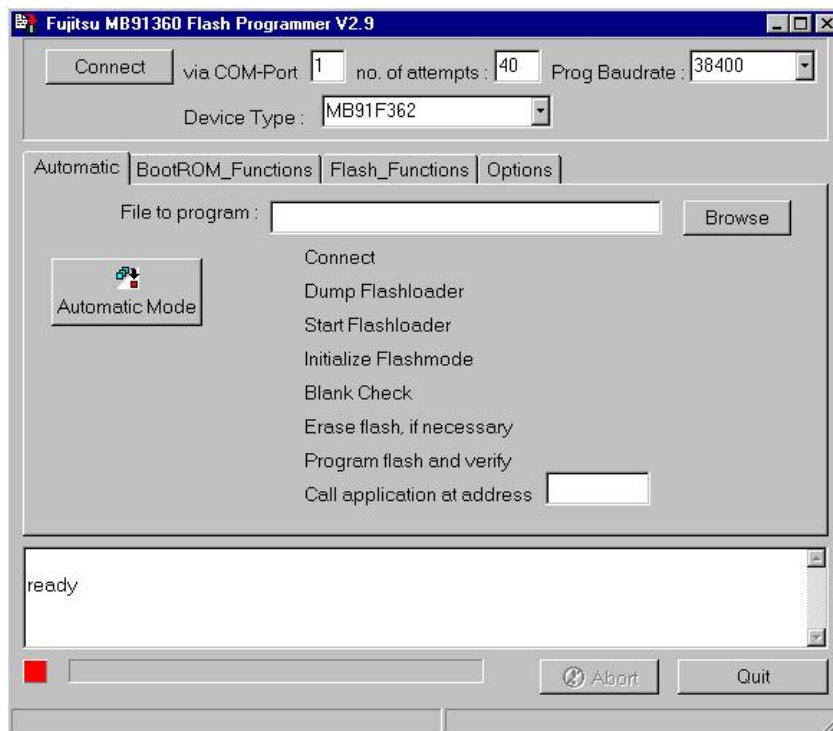

Figure 4: MB91360 Flash Programmer

Follow these steps to use the MB91360 Flash Programmer :

1. Be sure to have the starterkit in Monitor (single-chip) mode. Check the position of the jumpers and dip-switches onboard according to table1.
2. Connect the RS232-cable from any PC-COM-port to "UART0" (female UART connector on the left side of the Starterkit - do NOT use the monitor COM connector!).
3. Specify a (hex-)file in the "file to program"-field (use the browse-button to select). This file must be a converted linker output file from Softune in the Motorola Hex-Format "*.MHX" (for programming your own applications, be sure to have the load module converter started in Softune Workbench to generate MHX-files !). For kernel updates, select a MONxxx.MHX-file (xxx is the Starterkit-baudrate. E.g. : MON115.MHX is the kernel for 115200 Baud).
4. Specify the COM-port and the desired baud rate for programming.
5. Click on Automatic Mode and press monitor reset on the Starterkit. The programming sequence will be executed automatically.

CAUTION : DO NOT INTERRUPT THE FLASH PROGRAMMING OR CUT OFF THE POWER DURING PROGRAMMING !

IT CAN DAMAGE THE FLASH ROM PERMANENTLY !!!

6. After a successful programming procedure, hit monitor reset to re-initialize the Starterkit and close the program. Do not forget to plug the RS232-cable back to „Monitor COM“ if you want to use the monitor debugger again.

① The Flash Programmer uses the internal Boot-ROM functions instead of the monitor kernel for flash programming.

For more information and trouble shooting, see the „MB91360 Serial flash programmer user's guide“ (Flashprg.pdf) which is included in the installation.

6 Evaluation Board Hardware

6.1 Board Components

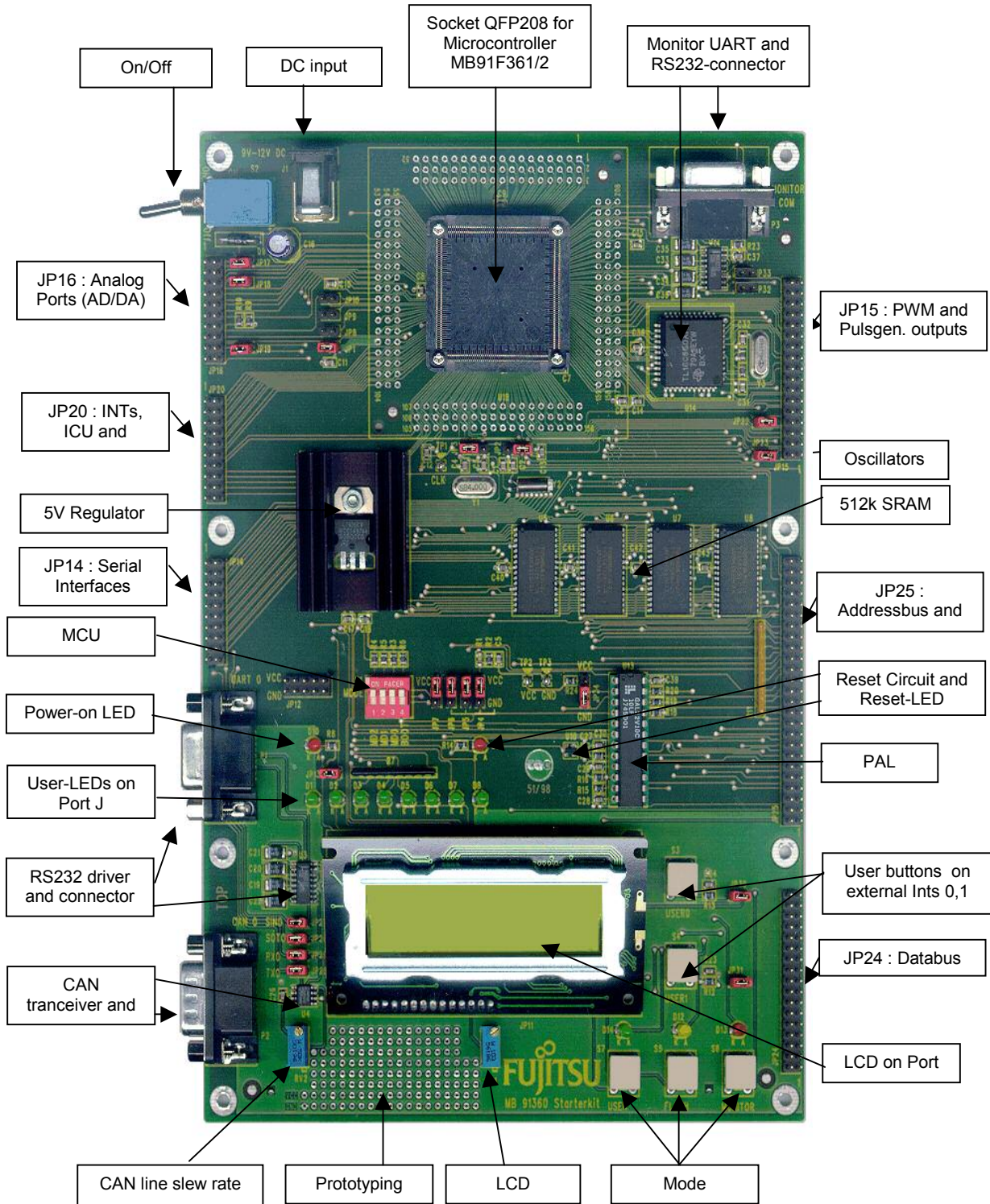

The evaluation board provides various IO-signals, which can be connected to external devices. The controller resource functions are available on the connectors JP14, JP15, JP16 and JP20.

External peripheral devices can be connected via the address/data bus on JP24 and JP25. For more information please refer to the following pin assignments and the schematics in the appendix.

6.2 Overview of Jumpers

Jumper	Description	Standard Setting →	Jumper Position
JP1	Main Vcc Net for MCU	Closed (Vcc supplied)	Closed
JP2	32kHz-Oscillator	GND (X0A disabled)	(2-3 closed) Right
JP3	4 MHz-Oscillator	X0 (Active)	(1-2 closed) Left
JP4	LPF for 32kHz-Oscillator	Vcc (Enabled)	(2-3 closed) Up
JP5	Clock Select Pin	Vcc (4 MHz)	(2-3 closed) Up
JP6	Hardware Standby Pin	Vcc (Disabled)	(2-3 closed) Up
JP7	Select Source MD0	Vcc (PAL)	(2-3 closed) Up
JP8-10	Test Mode Enable	Open (no test mode)	Open
JP13	LED enable	Closed (LEDs active)	Closed
JP17-19	Analog Supply Voltage	Closed (A/D active)	Closed
JP22-23	Driver Supply Voltage	Closed (Driver active)	Closed
JP26	Serial Output 0 enable	Closed (enabled)	Closed
JP27	Serial Input 0 enable	Closed (enable)	Closed
JP28-29	CAN0 driver enable	Closed (enable)	Closed
JP30,31	USER-buttons enable	Closed (enable)	Closed
JP32	Ext. UART int. enable	Open (disable)	Open
JP33	DTR reset enable	Open (disable)	Open
JP34	Power-up mode	GND (Monitor mode)	(1-2 closed) Down
MD2	Mode-Pin 2	GND	On (Upper Dip Pos)
MD1	Mode-Pin 1	GND	On
MD0	Mode-Pin 0	GND	On
BOOT	Boot-Pin	GND	On

Table 1: Selection jumpers on MB91360 Starterkit

Jumper	Description
JP12	Vcc/Gnd array for testpurposes
JP14	Serial communication pins (UART0-3 , CAN0-2)
JP15	Puls generator outputs 0-7, Stepper motor (PWM) outputs 0-4
JP16	A/D inputs 0-7, Alarm comp. Input, Sound gen. Output, D/A outputs 0-1
JP20	External Interrupts 0-7, Input Capture 0-3, Output Compare 0-3, I ² C
JP25	Adressbus A0-A20 and Bus-control signals
JP24	Databus D0-D31

Table 2: Grouped jumpers on MB91360 Starterkit

6.3 Connectors for resources and IO-signals

MCU-pins are grouped according to their logical functions. See the hardware manual for details on the resource functions.

JP16 :

- Analog Inputs (ADC)
- Analog Outputs (DAC)
- Sound Generator
- Alarm Comparator

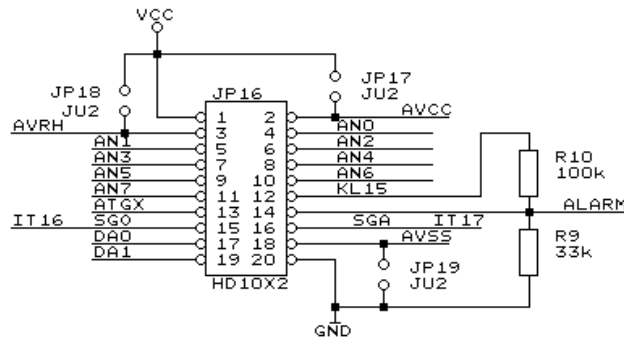

JP20 :

- External Interrupts,
- Input Capture Units
- Output Compare Units
- I²C Interface

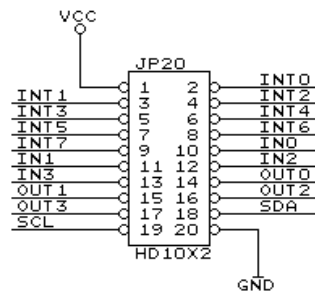

JP14 :

- UARTs
- Sync. serial interfaces
- CANs

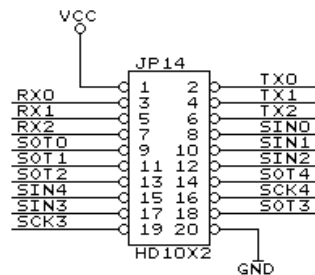

JP15 :

- Stepper Motor Drivers
- PWMs
- Puls Generators

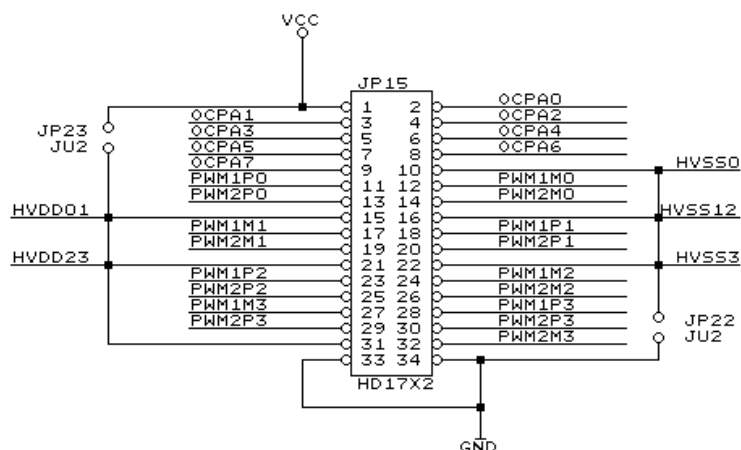

The available resource pins can also be used as general purpose IO-ports (using the Port-function registers PFRx). See table below for details.

Note: Address bus and data bus pins (JP24,25) cannot be used as IO-ports.

Jumper	Pin-No.	Pin Name	IO-Port	Resource Function
JP16	064	AVCC	-	Analog Vcc
	065	AVRH	-	Analog Reference High
	066	AN0	PH0	ADC Input Channel 0
	067	AN1	PH1	ADC Input Channel 1
	068	AN2	PH2	ADC Input Channel 2
	069	AN3	PH3	ADC Input Channel 3
	070	AN4	PH4	ADC Input Channel 4
	071	AN5	PH5	ADC Input Channel 5
	072	AN6	PH6	ADC Input Channel 6
	073	AN7	PH7	ADC Input Channel 7
	074	AVSS	-	Analog Reference Low
	077	ALARM	-	Alarm Comparator Input
	080	ATGX	PI3	ADC Trigger Input
	126	SGO	PM0	Sound Generator Output
	127	SGA	PM1	Sound Generator Amplitude
	075	DA0	-	DAC Output Channel 0
	076	DA1	-	DAC Output Channel 1
JP20	094	INT0	PK0	Ext. Interrupt 0
	095	INT1	PK1	Ext. Interrupt 1
	096	INT2	PK2	Ext. Interrupt 2
	097	INT3	PK3	Ext. Interrupt 3
	098	INT4	PK4	Ext. Interrupt 4
	099	INT5	PK5	Ext. Interrupt 5
	100	INT6	PK6	Ext. Interrupt 6
	101	INT7	PK7	Ext. Interrupt 7
	102	IN0	PL0	ICU Input 0
	103	IN1	PL1	ICU Input 1
104	IN2	PL2	ICU Input 2	
105	IN3	PL3	ICU Input 3	
106	OUT0	PL4	OCU Output 0	

Jumper	Pin-No.	Pin Name	IO-Port	Resource Function
	107	OUT1	PL5	OCU Output 1
	108	OUT2	PL6	OCU Output 2
	109	OUT3	PL7	OCU Output 3
	128	SDA	PM2	I2C-Interface SDA
	129	SCL	PM3	I2C-Interface SCL
JP14	146	TX0	PP0	CAN 0 TX
	147	RX0	PP1	CAN 0 RX
	148	TX1	PP2	CAN 1 TX
	149	RX1	PP3	CAN 1 RX
	150	TX2	PP4	CAN 2 TX
	151	RX2	PP5	CAN 2 RX
	152	SIN0	PQ0	UART 0 Input
	153	SOT0	PQ1	UART 0 Output
	154	SIN1	PQ2	UART 1 Input
	155	SOT1	PQ3	UART 1 Output
	156	SIN2	PQ4	UART 2 Input
	157	SOT2	PQ5	UART 2 Output
	130	SOT4	PN0	SIO Output
	131	SIN4	PN1	SIO Input
	132	SCK4	PN2	SIO Clock
	133	SIN3	PN3	SIO Input
	134	SOT3	PN4	SIO Output
	135	SCK3	PN5	SIO Clock
JP15	136	OCPA0	PO0	PPG Output 0
	137	OCPA1	PO1	PPG Output 1
	138	OCPA2	PO2	PPG Output 2
	139	OCPA3	PO3	PPG Output 3
	140	OCPA4	PO4	PPG Output 4
	141	OCPA5	PO5	PPG Output 5
	142	OCPA6	PO6	PPG Output 6
	143	OCPA7	PO7	PPG Output 7

Jumper	Pin-No.	Pin Name	IO-Port	Resource Function
	162	PWM1P0	PR0	SMC 0
	163	PWM1M0	PR1	SMC 0
	164	PWM2P0	PR2	SMC 0
	165	PWM2M0	PR3	SMC 0
	166	HVDD	-	SMC Driver Vdd
	167	PWM1P1	PR4	SMC 1
	168	PWM1M1	PR5	SMC 1
	169	PWM2P1	PR6	SMC 1
	170	PWM2M1	PR7	SMC 1
	171	HVSS	-	SMC Driver Vss
	172	PWM1P2	PS0	SMC 2
	173	PWM1M2	PS1	SMC 2
	174	PWM2P2	PS2	SMC 2
	175	PWM2M2	PS3	SMC 2
	177	PWM1P3	PS4	SMC 3
	178	PWM1M3	PS5	SMC 3
	179	PWM2P3	PS6	SMC 3
	180	PWM2M3	PS7	SMC 3

Table 3: Overview of available resource-functions and IO-ports on jumpers

7 Appendix

7.1 Memory Mappings MB91F362

7.1.1 MODE 000 (Single-Chip / Monitor Mode)

MB91F362 Memory Map

Recommended Mappings

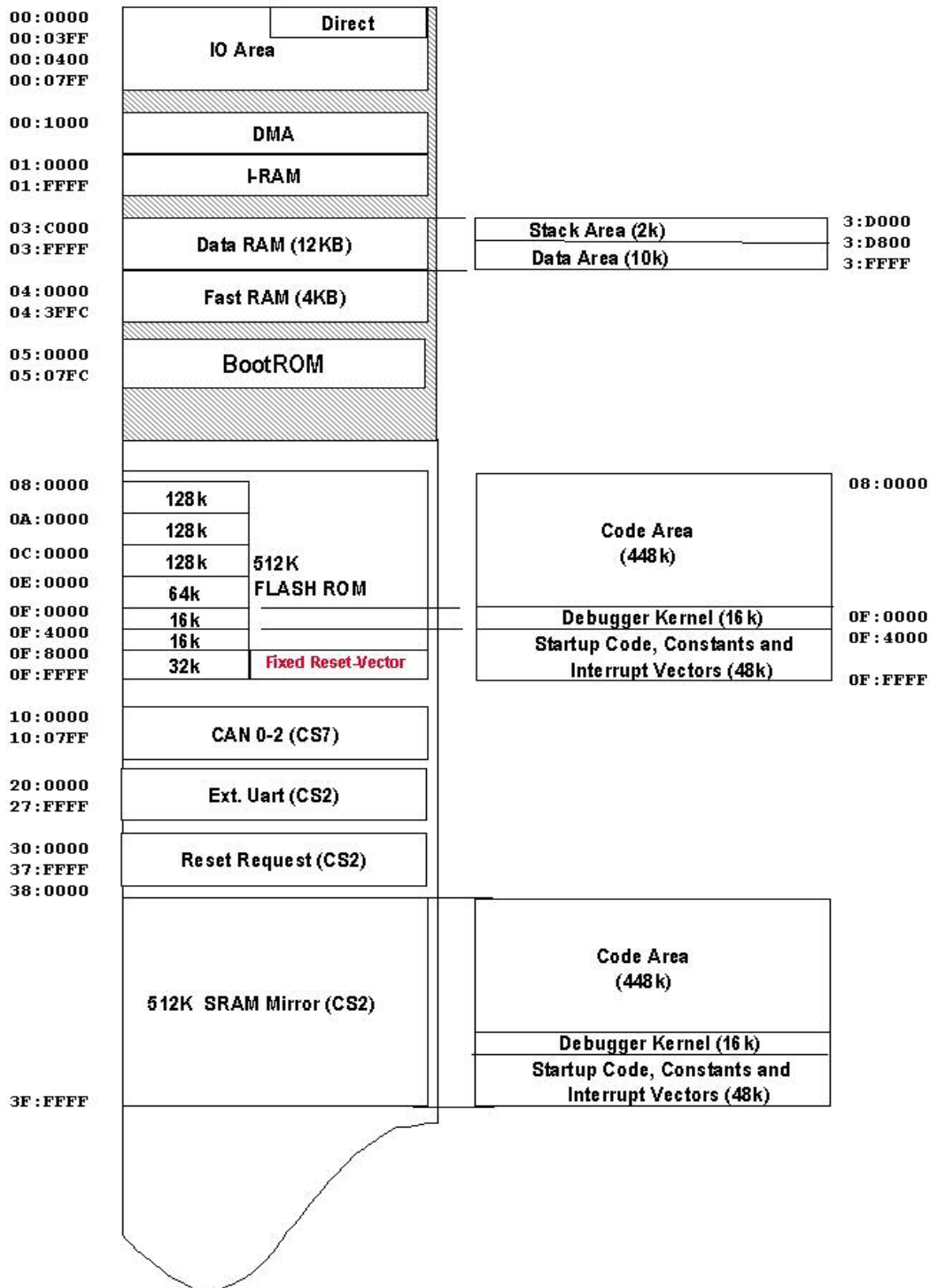

Figure 5: Memory Mapping Single Chip Mode / Monitor Mode

7.1.2 MODE 001 (External Bus / User Mode)

MB91F362 Memory Map

Recommended Mappings

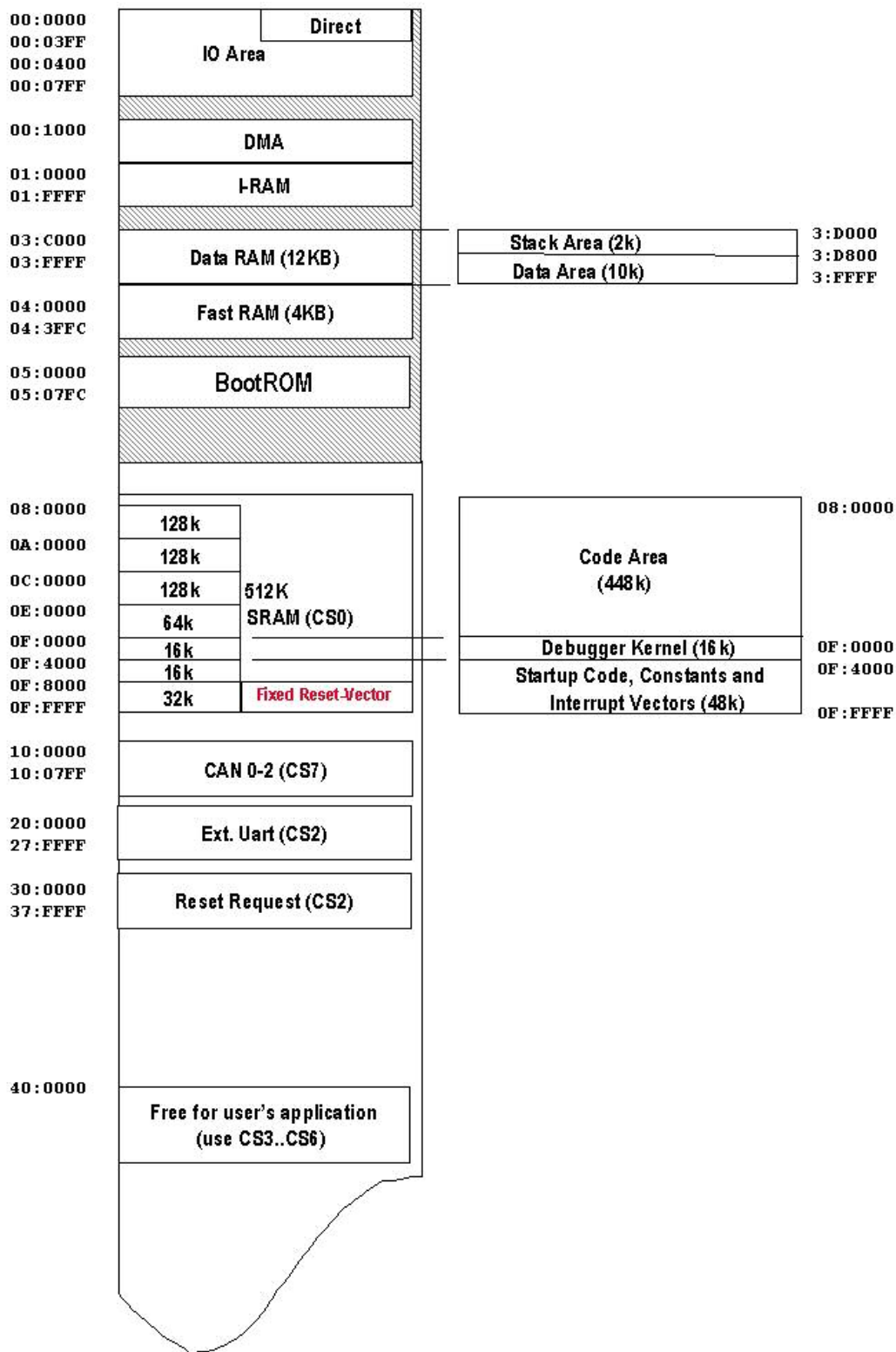

Figure 6: Memory Mapping External Mode / User Mode

7.2 Tool options for own projects

Valid load module files for MB91360 devices can only be achieved if the language tool configuration is appropriate. If you use the provided samples or templates, you do not have to worry about these settings.

The most convenient way to create own projects is to copy the provided Template-Project from the sample-directory and use it as “blank sheet”. However, if you intend to create projects “from scratch” without the template, the following settings are important.

Target MCU (“Project – Setup” menu) : make sure “MB91FV360” or “MB91F362” is selected as the target MCU device.

Linker Settings (“Project – Setup tool options – Linker – Disposition”) : MB91360 devices use a fixed memory map for code stored in Flash-ROM or data assigned to the internal RAM. In addition, certain Flash-sectors have special meanings, such as the boot-sector (application always starts from 0F4000) or the kernel of the debugger stored from 0F0000. Therefore, make sure the following memory map is applied:

Memory Type	Used for	Area	Sections
Data RAM	Stack	3D000..3DFFF	STACK
Data RAM	Variables	3E000..3FFFF	DATA, INIT
Flash ROM	User Code	080000..0EFFFF	CODE
FlashROM	Kernel	0F0000..0F3FFF	1.1.1.1.1 Reserved !
FlashROM	Boot-Sector, constants and vectors	0F4000..0FFFFFF	START, CONST, @INIT, VECTORS

Table 4: Memory Map

Your linker settings should look like this:

```
-ro CODE_AREA=0x00080000/0x000EFFFF
-ro ROM_AREA=0x000F4000/0x000FFFFFF
-ra STACK_AREA=0x0003D000/0x0003DFFF
-ra RAM_AREA=0x0003E000/0x0003FFFF
-sc STACK/Stack=STACK_AREA
-sc DATA/Data+INIT=RAM_AREA
-sc CODE/Code=CODE_AREA
-sc START+CONST+@INIT=ROM_AREA
```

Also refer to the detailed memory maps in the appendix.

① Always check the “map”-file (use the context menu in the project-view and select “open list file”) to see the used sections and addresses !

7.3 Starterkit limitations

If creating new projects, be sure **not** to use the following functions, which are reserved for the MB91360 Starterkit:

- ▶ Flash-ROM area 0F0000..0F3FFF (reserved for Monitor kernel)
- ▶ Port G / upper ADC inputs (used for LCD and mode input)
- ▶ Security-Vector (used to call the kernel in Monitor mode)
- ▶ External Interrupt 0 (used for Abort function)
- ▶ Chip selects 0,2 and 7 (used for MCU and board hardware)
- ▶ External memory space 200000..3FFFFFF (used for board hardware)

7.4 Board Schematics

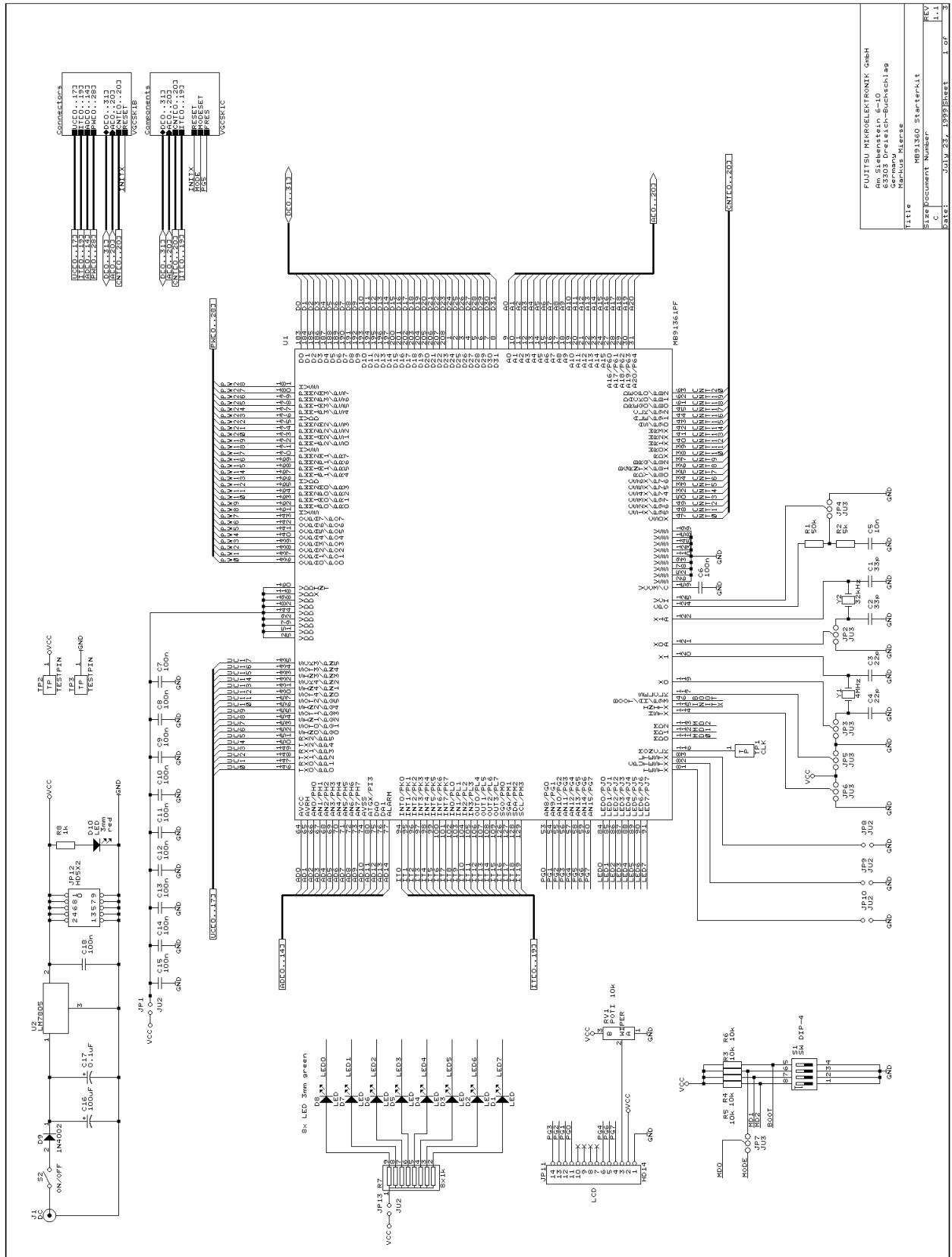

FUJITSU MIKROELEKTRONIK GmbH Am Slesenerstra. 6-10 62303 Dreieich-Buchschiep Markus-Miese	
Title	MB91360 StarterKit
Size	Document Number
REV	1.1
Date:	July 23, 1999/Sheet 1 of 9

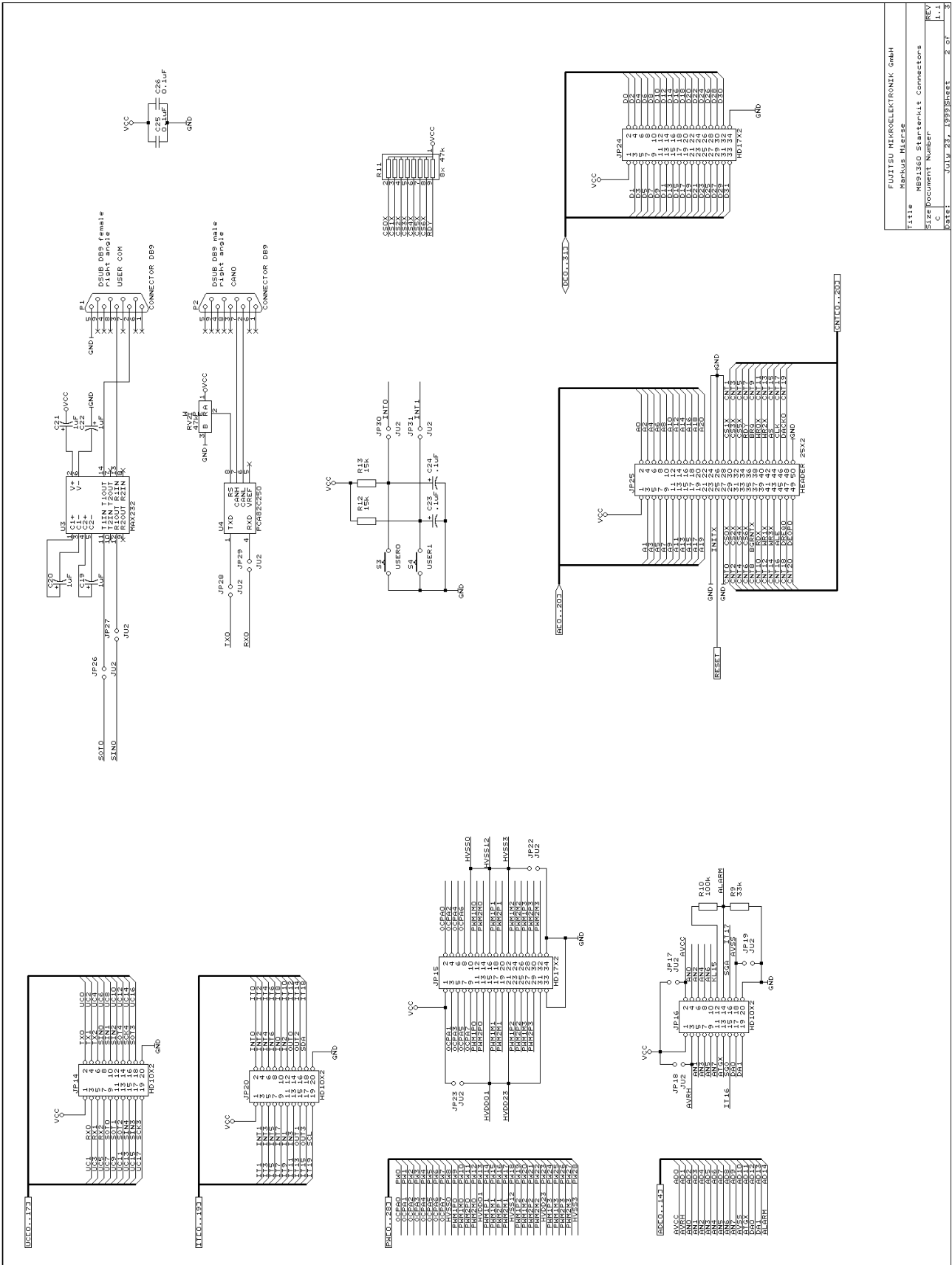

FUJITSU MICROELEKTRONIK GmbH	
Title: MB91360 Starter-Kit Connectors	
Size:	Document Number: 1-3
Date:	JUL 23, 1999 Sheet 2 of 3

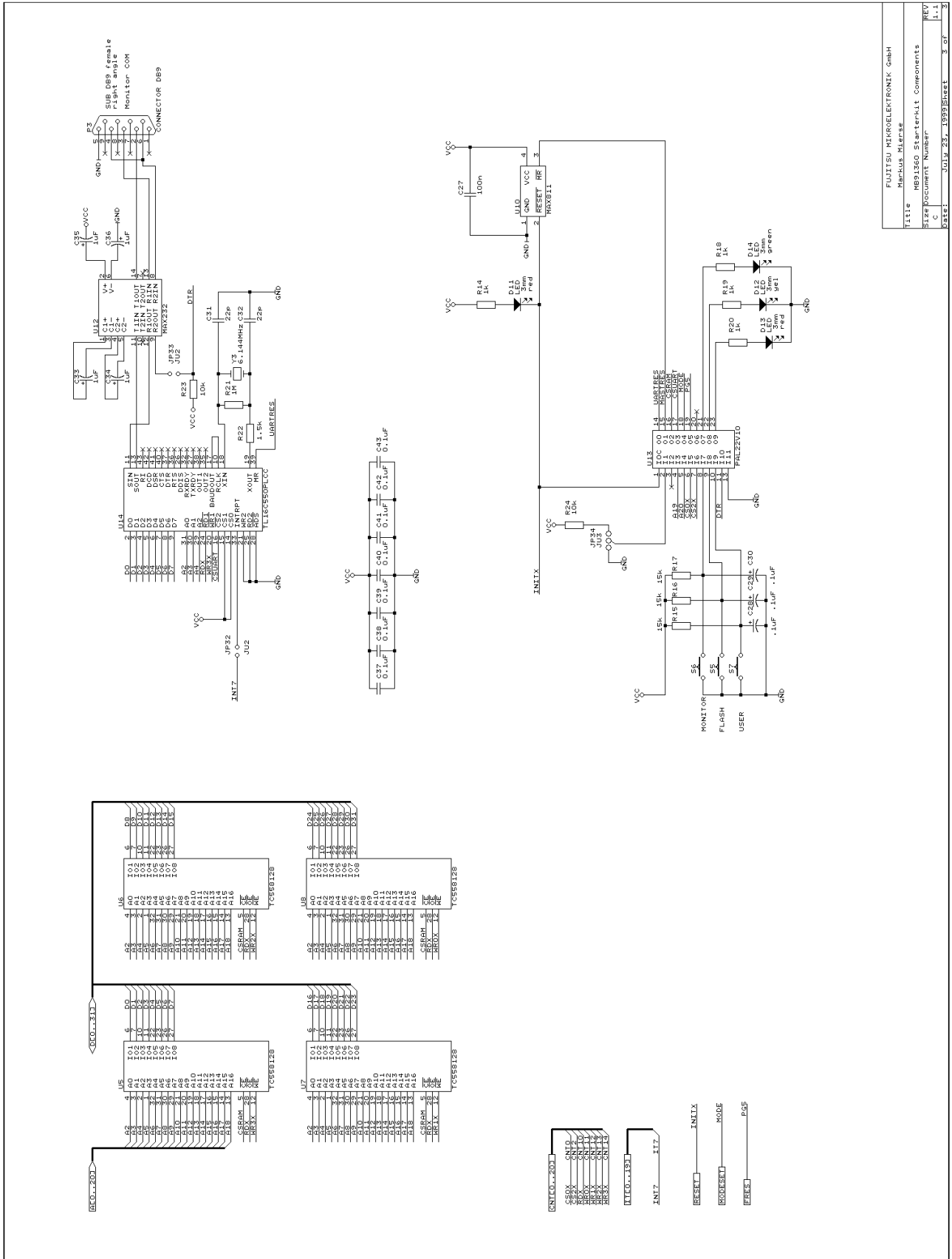

Title	Mechus_Micrse
Size	MB91360 Starterkit Components
Document Number	UG-91006-13
Date	July 23, 1999 Sheet 3 of 3

7.5 Silk Screen

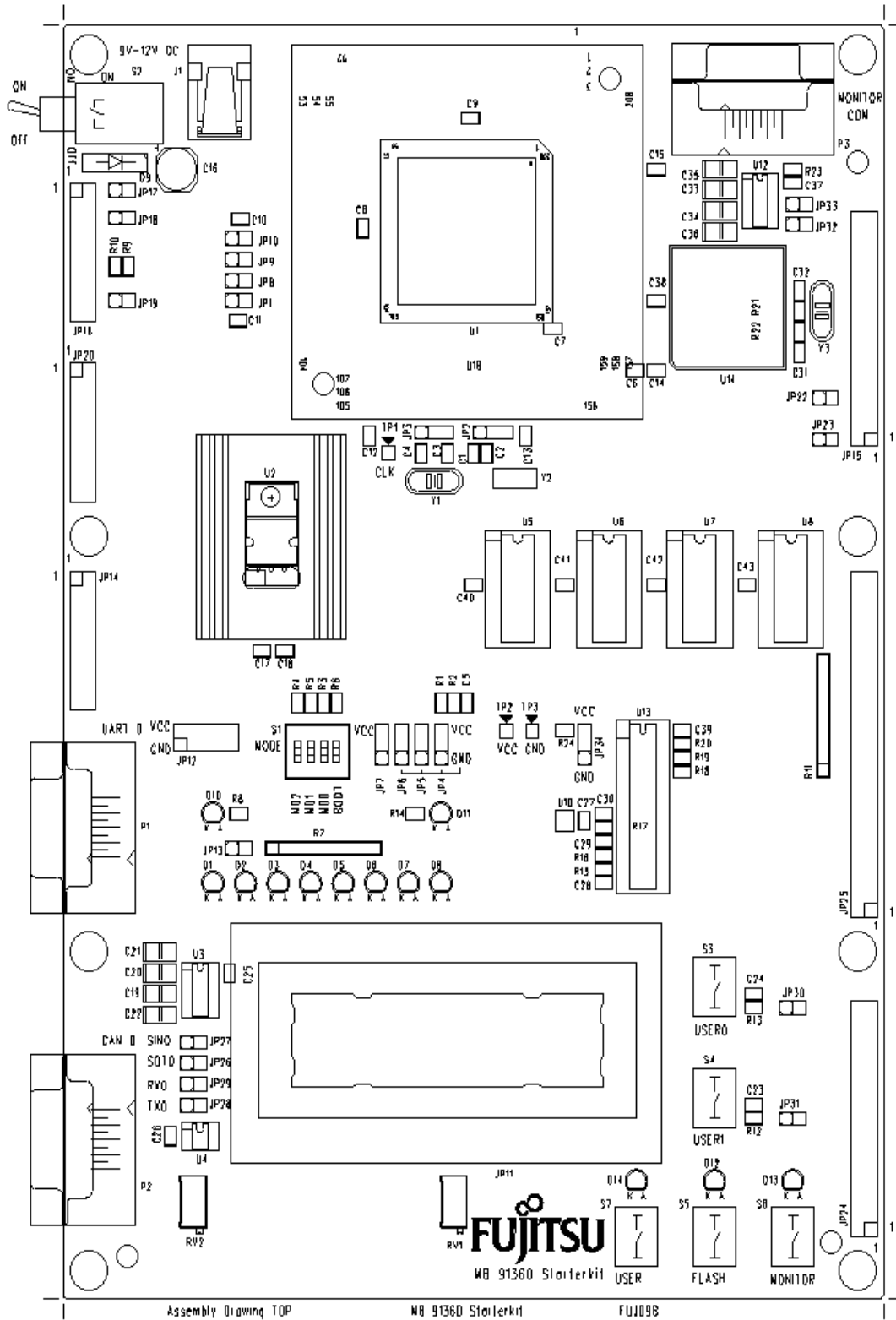

7.6 PAL Listing

```

;PALASM Design Description
;----- Declaration Segment -----
TITLE      STK360_1.PDS
PATTERN    A
REVISION    1.3
AUTHOR      M.MIERSE
COMPANY     FUJITSU MIKROELEKTRONIK GMBH
DATE        20/09/99
CHIP        STK360   PAL22V10
; ----- Revision History -----
;
; 20.11.98 V1.0 First Version
; 17.02.99 V1.1 Rem-Req and ext. UART Mapping changed
; 16.03.99 V1.2 UART-Reset changed to high-active
; 20.09.99 V1.3 UART-CS changed for ext.bus mode
;
;----- PIN Declarations -----
PIN 1      RESETIN      COMBINATORIAL      ; INPUT
PIN 2      DEFAULT      COMBINATORIAL      ; INPUT
PIN 3      AUXIN        COMBINATORIAL      ; INPUT
PIN 4      A19           COMBINATORIAL      ; INPUT
PIN 5      A20           COMBINATORIAL      ; INPUT
PIN 6      CS0           COMBINATORIAL      ; INPUT
PIN 7      CS2           COMBINATORIAL      ; INPUT
PIN 8      MONRES       COMBINATORIAL      ; INPUT
PIN 9      FLASHRES     COMBINATORIAL      ; INPUT
PIN 10     USERRES     COMBINATORIAL      ; INPUT
PIN 11     DTR          COMBINATORIAL      ; INPUT
PIN 13     UNUSED1     COMBINATORIAL      ;
PIN 12     GND          COMBINATORIAL      ;
PIN 14     UARTRES     COMBINATORIAL      ; OUTPUT
PIN 15     MASTRES     COMBINATORIAL      ; OUTPUT
PIN 16     CSRAM       COMBINATORIAL      ; OUTPUT
PIN 17     CSUART     COMBINATORIAL      ; OUTPUT
PIN 18     MODE        COMBINATORIAL      ; OUTPUT
PIN 19     PG5         COMBINATORIAL      ; OUTPUT
PIN 20     PONFLAG     REGISTERED      ; INT. FLAG
PIN 21     LEDGRN      COMBINATORIAL      ; OUTPUT
PIN 22     LEDYEL      COMBINATORIAL      ; OUTPUT
PIN 23     LEDRED      COMBINATORIAL      ; OUTPUT
PIN 24     VCC         COMBINATORIAL      ;
; -----
; ----- OUTPUT EQUATIONS -----
; -----

```

EQUATIONS

```

; -----
; Power-on Indicator (Flip-Flop) :
; -----

PONFLAG.CLKF = RESETIN      ; Power-on-Flag ist 0 at Pon ; otherwise 1
PONFLAG := 1

; -----
; Equations for Modes (Reset-States) :
; -----

; -----> LEDRED is indicating the Monitor-Reset state, if
LEDRED = USERRES * FLASHRES * /MONRES      ; Mon-reset button pressed
        + /DTR                               ; or uart-reset (DTR line low)
        + (/PONFLAG * /DEFAULT)             ; or Power-on (Default-Mode=Mon)
        + /LEDGRN * /LEDYEL                 ; (hold-condition)

; -----> LEDGRN is indicating the User-Reset state, if
LEDGRN = /USERRES * FLASHRES * MONRES       ; User-Reset button pressed
        + (A20 * /A19 * /CS2)               ; or Remote-User-reset request
        + /LEDYEL * /LEDRED                 ; (hold-condition)

; -----> LEDYEL is indicating the Flash-Reset state, if
LEDYEL = USERRES * /FLASHRES * MONRES      ; Flash-Reset button pressed
        + (/PONFLAG * DEFAULT)              ; or Power-on (Default-Mode=Flash)
        + /LEDGRN * /LEDRED                 ; (hold-condition)

MODE = LEDGRN      ; Mode-Pin (MD0) is 1, if User-Reset state, otherwise 0
PG5  = LEDYEL      ; Flash-Ind-Pin is 1, if Flash-Reset state, otherwise 0

UARTRES = /RESETIN * LEDRED ; UART-reset only if Monitor-Reset

; -----
; Reset-Request : Toggles the Masterreset-input (MAX811), if
; -----

/MASTRES = ((/MONRES + /USERRES + /FLASHRES) * RESETIN) ; Buttons pressed
           + (( LEDGRN * /A19 * A20 ) * RESETIN)         ; or Rem-Request
           + ((/DTR ) * RESETIN)                         ; or DTR low

; -----
; Memory-Mapping Equations :
; -----

```

```

; SRAMS active in areas :
/CSRAM =  (/A20 * A19 * /CS0)      ; 08:0000...0F:FFFF (CS0)
          + ( A20 * A19 * /CS0)      ; 18:0000...1F:FFFF (CS0)
          + ( A20 * A19 * /CS2)      ; 38:0000...3F:FFFF (CS2)

; UART-Area = 20:0000...27:FFFF (CS0 in Monitor-mode or CS2 in USER mode)

/CSUART = (LEDRED * /A20 * /A19 * /CS0) ; CS0 in Mon-Mode
          + (LEDGRN * /A20 * /A19 * /CS2) ; CS2 in User-Mode

```

7.7 Development tools and accessories

In-Circuit Emulation Tools for MB91360 Series:

Emulation Main Unit	MB2197-01
Emulation Board	MB2197-120
Emulation Header (Probe)	MB2197-127
Evaluation Device	MB91FV360GCR
Evaluation Board	StarterkitMB91360

In-Circuit Emulation Tools for MB91100 Series:

Emulation Main Unit	MB2197-01
RAM Stack	FR-RAM-STACK1-100P-M06
Header	MB2197-111
Header	MB2197-112
Header	MB2197-115
Evaluation Device	MB91V10x(A)CR
Evaluation Board	StarterkitMB91100

Accessories:

Serial Cable	Extension type
QFP208 Socket	NQ-PACK208SD
Socket IC Lid	HQ-PACK208SD
ICE-socket adapter	YQ-PACK208SD
Test-PCB for Starterkit	QFP208 footprint to 2.54mm pin rows
Power supply	9-12V DC (0.5A)

7.8 Related Documents

Available manuals for MB91360 series :

1. MB91360 Hardware Manual
2. MB91F36X Datasheet (General Specification)
3. FR Family C-Compiler Manual
4. FR Family Instruction Manual
5. FR Family Assembler Manual
6. FR Family Simulator Manual
7. FR Family Emulator Manual
8. FR Family Linkage Kit Manual
9. FR Family Softune Workbench Manual

Note : All documents are available from the provided CD-ROM, Fujitsu's Microcontroller CD-ROMs or from our web-site.

7.9 Trouble Shooting

Problem	Solution
<p>Evaluationboard does not initialize after power-on. LED D10 (Power indicator) does not light up and the LC-display remains empty.</p>	<p>Check voltage supply and jumpers :</p> <ul style="list-style-type: none"> ☛ The voltage on DC-Power plug should be in the range of 9-12V. The plug should have + on shield and – on the center. LED D10 should light up after switching on the board. Use a multimeter to see whether 5V are present on the Vcc/Gnd terminals (TP2 and TP3). ☛ Check jumper positions according to table 1 (Esp. : JP1 – JP7) ! ☛ Remove all user extensions on the board to avoid shorts !
<p>Evaluationboard stays in reset. LED D11 (Reset indicator) lighs up permanently.</p>	<ul style="list-style-type: none"> ☛ LED D11 (Reset) should flash. If D11 lights up permantantly, the voltage is too low (below 4.25V) - Increase the voltage to solve the problem. ☛ JP33 (DTR reset) should be left open. This option allows to reset the board from a connected PC using the DTR line (not used by Softune WB). ☛ Remove all user extensions on the board to avoid shorts or leakage currents !
<p>After power-on, the initial monitor-message is not shown on the LCD.</p>	<ul style="list-style-type: none"> ☛ Check JP34 (default-mode) : This jumper should be in the lower position (Monitor mode). In the upper position, the board will call the user program in Flash-ROM directly and will not show the message. ☛ Maybe the monitor-kernel has been destroyed. Try to re-program the kernel as described in the „flash programming“-section. ☛ Check all jumper positions (table 1). ☛ Adjust the LCD contrast using potentiometer RV1.
<p>The communication from Softune Workbench to the</p>	<ul style="list-style-type: none"> ☛ Make sure your COM-port number and the baudrate settings are correct

Problem	Solution
evaluation board fails (Communication errors)	<p>(see debugger introduction).</p> <ul style="list-style-type: none"> ☛ Make sure no other programs are using the same COM-port on your PC. Close all other applications (e.g. Flash programmer utilities, terminals etc.) ☛ Use the provided RS232-cable (1:1 extension type) to connect from your PC to the „Monitor COM“ connector. ☛ If you are using a PC without a fast UART (16550 type), you have to switch to a lower baudrate (e.g. 38400 Baud) and re-program the kernel according to this baudrate (see „flash programming“ section).
The program stops at the label „uninitialized interrupt !“	<ul style="list-style-type: none"> ☛ Before downloading a new project to the evaluation board, re-initialize using the Monitor-Reset. This will erase all valid interrupt definitions from previous programs executed on the starterkit. ☛ Make sure you haven't enabled any interrupts that have no interrupt handler (see the <code>INTVECT.INC</code> file) ! <p>Note : Since the „Abort“-function uses the external interrupt 0, interrupts are usually enabled !</p>
Hardware units such as LEDs, user buttons, UART0 or CAN are not working.	<ul style="list-style-type: none"> ☛ Make sure you have enabled these units on the evaluation board using the appropriate jumpers (e.g. JP13 for LEDs). See the provided examples and the hardware manual for information on how to control the peripherals.
CAN devices do not respond	<ul style="list-style-type: none"> ☛ Adjust the potentiometer RV2 (slew rate) according to the line.

Table 5: Trouble Shooting

For more information see the Softune Workbench on-line help, the provided manuals, last minute information and additional or updated documentation on our web-site.

7.10 Figures

Figure 1: Using the Starterkit as target board for the ICE	7
Figure 2: Softune Workbench Editor	11
Figure 3: SWB Debugging window	14
Figure 4: MB91360 Flash Programmer	20
Figure 5: Memory Mapping Single Chip Mode / Monitor Mode	29
Figure 6: Memory Mapping External Mode / User Mode	30

7.11 Tables

Table 1: Selection jumpers on MB91360 Starterkit.....	23
Table 2: Grouped jumpers on MB91360 Starterkit	24
Table 3: Overview of available resource-functions and IO-ports on jumpers	28
Table 4: Memory Map	31
Table 5: Trouble Shooting	42

-- END --

Free Manuals Download Website

<http://myh66.com>

<http://usermanuals.us>

<http://www.somanuals.com>

<http://www.4manuals.cc>

<http://www.manual-lib.com>

<http://www.404manual.com>

<http://www.luxmanual.com>

<http://aubethermostatmanual.com>

Golf course search by state

<http://golfingnear.com>

Email search by domain

<http://emailbydomain.com>

Auto manuals search

<http://auto.somanuals.com>

TV manuals search

<http://tv.somanuals.com>