

FUJITSU DL1100
DOT MATRIX PRINTER
USER'S MANUAL
AND
PROGRAMMER'S MANUAL

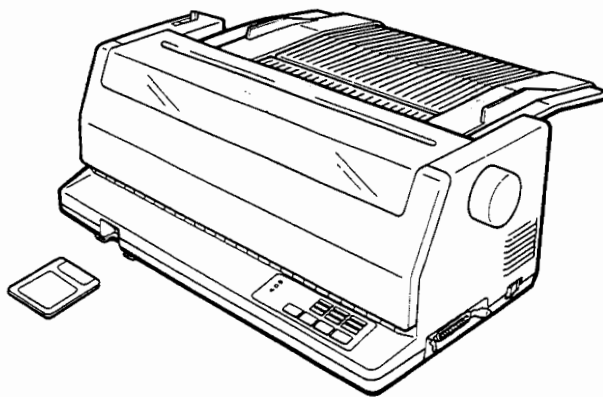

**Federal Communications Commission
Radio Frequency Interference Statement
for United States Users**

This equipment generates and uses radio frequency energy. If it is not installed and used properly, that is, in strict accordance with the manufacturer's instructions, it may cause interference to radio and television reception. It has been type tested and found to comply with the limits for a Class B computing device in accordance with the specification in Subpart J of Part 15 of FCC Rules, which are designed to provide reasonable protection against such interference in residential installation. However, there is no guarantee that interference will not occur in a particular installation. If this equipment does cause interference to radio or television reception, which can be determined by turning the equipment off and on, the user is encouraged to try to correct the interference by one or more of the following measures:

- Reorient the receiving antenna.
- Relocate the equipment with respect to the receiver.
- Move this equipment away from the receiver.
- Plug this equipment into a different outlet so that the equipment and receiver are on different branch circuits.

If necessary, the user should consult the dealer or an experienced radio/television technician for additional suggestions. The user may find the following booklet prepared by the Federal Communications Commission helpful: "How to Identify and Resolve Radio-TV Interference Problems." This booklet is available from the US Government Printing Office, Washington, D.C., 20402, Stock No. 004-000-000345-4.

(This equipment has been tested as M3368A of the model number.)

NOTES

1. **The use of a non-shielded interface cable with the referenced device is prohibited. The length of the parallel interface cable must be 3 meters (10 feet) or less. The length of the serial interface cable must be 15 meters (50 feet) or less.**
2. **The length of the power cord must be 3 meters (10 feet) or less.**

Notice for Canadian Users

This digital apparatus does not exceed the class B limits for radio noise emissions from digital apparatus set out in the Radio Interference Regulations of the Canadian Department of Communications.

Le présent appareil numérique n'émet pas de bruits radioélectriques dépassant les limites applicables aux appareils numériques de la classe B prescrites dans le Règlement sur le brouillage radioélectrique édicté par le ministère des Communications du Canada.

Notice for German Users

Dieses Gerät entspricht als Einzelgerät den Funkenstörungsanforderungen der Postverfügung Nr. 1046/1984 bzw. der Grenzfläche B nach VDE 0871/6.78. Das Kabel muß abgeschirmt und unter 3 Meter lang sein.

The contents of this manual may be revised without prior notice, and without obligation, to incorporate changes and improvements into units already shipped.

Every effort has been made to ensure that the information included here is complete and accurate at the time of publication, but Fujitsu cannot be held responsible for errors and omissions.

The specifications of the printer models differ with power supply (input voltage).

B-69642 Rev. D October 1990

Copyright © 1989, 1990 FUJITSU LIMITED

Printed in Japan. All rights reserved. No part of this manual may be reproduced or translated, stored in a database or retrieval system, or transmitted, in any form or by any means, electronic, mechanical, photocopying, recording, or otherwise, without the prior written permission of the copyright owner.

TRADEMARK ACKNOWLEDGMENTS

FUJITSU is a registered trademark of Fujitsu Limited. Centronics is a trademark of Centronics Data Computer Corporation. IBM PC and IBM Proprinter XL24 are trademarks of International Business Machines Corporation. LQ-2500 and LQ-2550 are trademarks of Seiko Epson Corporation. Diablo 630 is a trademark of Diablo Systems Incorporated and Xerox Corporation. DEC LA50/75/120/210 is a trademark of Digital Equipment Corporation. MS-DOS and Microsoft BASIC are trademarks of Microsoft Corporation. Bitstream is a registered trademark of Bitstream Inc.

Other product names mentioned in this manual may also be trademarks used here for identification only.

This document contains technology relating to strategic products controlled by export control laws of the producing and/or exporting countries. This document or a portion thereof should not be exported (or re-exported) without authorization from the appropriate governmental authorities in accordance with such laws.

FUJITSU LIMITED

ABOUT THIS MANUAL

Thank you for buying this printer. You can expect years of reliable service with very little maintenance. This manual explains how to use your printer to full advantage. The manual has two parts:

- The first part, the *User's Manual*, explains how to set up, use, and maintain the Fujitsu DL1100 dot matrix printer and its options. This manual is written for both new and experienced users of printers.
- The second part, the *Programmer's Manual*, provides detailed information on the Fujitsu DPL24C PLUS command set. This manual is written for programmers or other users who want to learn more about the DPL24C PLUS command set.

Each manual has several appendices, a glossary, and an index. Appendix A of the *User's Manual* lists additional publications available for the printer. To obtain additional publications or information, please contact your dealer or authorized Fujitsu representative. Fujitsu subsidiaries are listed at the end of the manual.

USER'S MANUAL

This manual explains how to install, set up, and use your printer and its options. It also explains how to keep the printer in top working condition, and what to do should something go wrong. Detailed procedures are provided for first-time users. Experienced users may be able to skip some of the details, using the table of contents and chapter introductions to locate needed information.

ORGANIZATION

The manual is organized as follows:

The **Quick Reference** summarizes everyday printer operations. After you become familiar with the printer, use this section as a memory aid.

Chapter 1 introduces the printer, listing key features as well as options to enhance the printer's capabilities. **Chapter 2** gives step-by-step procedures for setting up the printer for immediate use. It also familiarizes you with the names of the printer's basic parts. If this is your first dot matrix printer, we recommend reading this chapter from start to finish.

Chapter 3 explains how to load and use paper with your printer, while **Chapter 4** covers basic printing operations. Everyday use of the printer's control panel, including paper loading and selection of print features, is detailed. After you know how the printer works, use the **Quick Reference** at the beginning of the manual to refresh your memory.

Chapter 5, Using Setup Mode, describes how to change the printer's optional settings such as print features, hardware options, and top-of-form. Most settings will only affect print features such as the typestyle and page format. But a few settings must be selected correctly for compatibility with your system hardware and software. Refer to this chapter as indicated in Chapter 2 or as required.

Chapters 6 through 8 provide information you'll need only occasionally. **Chapters 6 and 7** cover basic maintenance and problem solving. Before contacting your dealer for help, check the list of problems and solutions in Chapter 7. Finally, **Chapter 8** describes options available for the printer and how to install them.

At the end of this manual, you'll find several appendices, a glossary, and an index. Appendix A lists order numbers for the printer's consumables, options, and publications. The other appendices give additional technical information.

CONVENTIONS

You'll notice that **bold** and *italics* are used to call your attention to special information:

WARNING or CAUTION

A WARNING indicates that personal injury may result if you do not follow a procedure correctly. A CAUTION indicates that damage to the printer may result if you do not follow a procedure correctly.

NOTE

NOTEs provide "how-to" tips or suggestions to help you perform a procedure correctly. **NOTEs** are particularly useful for first-time users.

For Experienced Users:

If you're familiar with this printer or with dot matrix printers in general, this information will help you use the manual effectively.

TABLE OF CONTENTS

QUICK REFERENCE	QR-1
CHAPTER 1 INTRODUCTION	
Features	1-1
Options	1-2
CHAPTER 2 SETTING UP	
Selecting a Good Location	2-1
Unpacking	2-2
Assembling the Printer	2-4
Installing the Platen Knob	2-4
Installing the Cut Sheet Stand	2-5
Installing the Ribbon Cartridge	2-6
Getting Acquainted With Your Printer	2-9
Connecting the Power Cord	2-10
Testing the Printer (Offline)	2-12
Loading Paper for the Self-Test	2-12
Printing the Self-Test	2-13
Connecting the Printer to Your Computer	2-17
Selecting a Parallel Interface Cable	2-17
Selecting a Serial Interface Cable	2-17
Connecting the Interface Cable	2-18
Selecting an Emulation	2-18
Printing a Sample Page (Online)	2-22
CHAPTER 3 LOADING AND USING PAPER	
Selecting Paper	3-1
Overview of Paper Operations	3-2
Adjusting for Paper Thickness	3-4
Using Single Sheets	3-5
Loading a Single Sheet of Paper	3-5
Loading Paper in the Cut Sheet Feeder	3-8
Ejecting Single Sheets	3-11

Using Continuous Forms	3-12
Positioning the Paper Stack	3-12
Loading Continuous Forms	3-12
Unloading Continuous Forms	3-16
Tearing Off Forms	3-16
Feeding Paper	3-17
Switching Paper Types	3-18
Switching to Single Sheets	3-18
Switching to Continuous Forms	3-19
Tips on Handling Paper	3-19

CHAPTER 4 PRINTING

Selecting Print Features	4-1
Using Commercial Software	4-2
Using the Control Panel	4-2
Selecting MENU 1 or MENU 2	4-3
Changing the print quality	4-5
Changing the font/pitch	4-6
Printing	4-6
Start Printing	4-6
Stop Printing	4-7
Resuming from Paper-Out	4-7
Removing Printed Pages	4-8
Removing Single Sheets	4-8
Removing Continuous Forms	4-9
Clearing the Print Buffer	4-9

CHAPTER 5 USING SETUP MODE

Entering Setup Mode	5-2
Overview of Setup Mode	5-4
Printing a List of Selected Options	5-10
Deciding Which Options to Change	5-12
Changing Panel Options	5-14
Changing MENU 1 and MENU 2 Options	5-17
Changing Hardware Options	5-31
Changing Top-of-Form	5-37
Exiting and Saving	5-40

Resetting Defaults	5-41
Resetting Power-On Defaults	5-41
Resetting Factory Defaults	5-42
Resetting Defaults in MENU 1 and MENU 2	5-42
Using the Diagnostic Functions	5-43
Printing the Self-test	5-43
Printing Hex Dumps	5-46
Checking Vertical Print Alignment	5-48
Setup Mode Reference	5-51

CHAPTER 6 MAINTENANCE

Cleaning	6-1
Replacing the Ribbon Cartridge	6-3

CHAPTER 7 PROBLEM SOLVING

Problems and Solutions	7-1
Printing Problems	7-1
Paper Handling Problems	7-4
Operational Problems	7-6
Diagnostic Functions	7-8
Getting Help	7-8

CHAPTER 8 INSTALLING OPTIONS

Installing a Cut Sheet Feeder	8-1
Installing/Removing Font Cards	8-2
Installing/Removing Emulation Cards	8-4
Changing the Interface Board	8-6
Color Kits	8-7

APPENDIX A CONSUMABLES, OPTIONS, AND PUBLICATIONS	A-1
APPENDIX B PRINTER AND PAPER SPECIFICATIONS	B-1
APPENDIX C COMMAND SETS	C-1
APPENDIX D INTERFACE INFORMATION	D-1
GLOSSARY OF TERMS	GL-1
INDEX	IN-1



QUICK REFERENCE

This Quick Reference section is written for experienced users — those who are familiar with how the printer works, but who may need to refresh their memories occasionally. *Only the printer's normal (non-setup) mode is covered.* For details on setup mode, see Chapter 5.

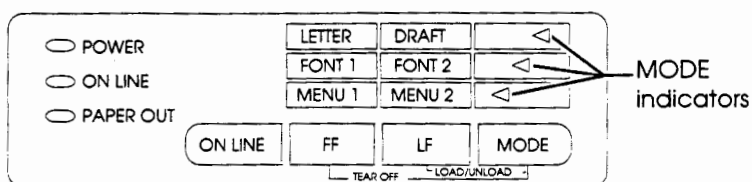

Printer Operations (Normal Mode)

- √ : Operation can be performed when the printer is in this state.
- : Operation cannot be performed when the printer is in this state.
- N/A : Does not apply.

Operation	Online	Offline		What You Do
		MODE Ind. OFF	ON	
Clear print buffer	√	√	√	Turn printer off.
Eject single sheets	√	√	—	Press FF.
Enter normal mode	N/A	N/A	N/A	Turn printer on.
Exit normal mode	√	√	√	Turn printer off (you cannot exit to setup mode).
Form feed (forward)	√	√	—	Press FF.
Line feed (forward)	√	√	—	Press LF.

Printer Operations (Normal Mode) Cont.

√ : Operation can be performed when the printer is in this state.
 — : Operation cannot be performed when the printer is in this state.
 N/A : Does not apply.

Operation	Online	Offline		What You Do
		MODE Ind. OFF	ON	
Load paper	√	√	—	Press MODE + LF. Or press FF (only when PAPER OUT is lit).
Place printer offline	√	—	—	Press ONLINE.
Place printer online	—	√	√	Press ONLINE.
Reset power-on defaults	√	√	√	Turn printer off, then on.
Select FONT 1 or FONT 2	—	—	√	With middle MODE indicator on, press FF or LF.
Select LETTER or DRAFT	—	—	√	With top MODE indicator on, press FF or LF.
Select MENU 1 or MENU 2	—	—	√	With bottom MODE indicator on, press FF or LF.
Start/stop/resume printing	√	—	—	Start: Send print command. Stop/resume: Press ONLINE.
Self-test printing	√	√	√	Start: Turn printer off. Press FF while turning printer on. Pause/resume: Press MODE or LF. Exit: Press ONLINE.
Tear off forms	√	√	—	Press MODE + FF. Tear off forms, press any button to retract forms.
Unload paper to park position (forms only)	√	√	—	Press MODE + LF.

INTRODUCTION

Congratulations on purchasing this printer. It is an ideal solution for those who require compact size and versatility, as well as maximum compatibility with today's software packages and personal computers. Using a 24-wire print head, the printer provides crisp printing for business, office, and home environments. Your printer is also easy to install and use.

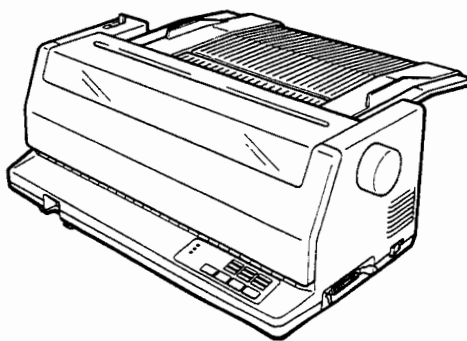

Dot matrix printer

Key printer features and useful options are listed in the next two sections.

FEATURES

- **Software compatibility.** Fujitsu DPL24C PLUS, IBM Proprinter XL24, Epson LQ-2500, and Epson LQ-2550 emulations are resident. Additional emulations are available on plug-in emulation cards.
- **Easy connection with most computers.** Choose either a Centronics parallel interface or an optional RS-232C serial interface for your printer.

- **Multiple font options.** Eight resident fonts: Courier 10, Pica 10, Prestige Elite 12, Boldface PS, Correspondence, Compressed font, Draft, and High-speed Draft (monochrome models only). Optional fonts available on font cards. Up to 31.75K bytes available for downloading fonts.
- **High-speed printing.** At 10 cpi, print speed ranges from 50 cps for letter quality printing to 200 cps for high-speed draft quality printing.
- **Large print buffer.** 24K maximum. Allows you to send files to the printer and return to work in your application.
- **110-column print line.** Allows printing in landscape mode using letter or A4 size paper.
- **Superior paper handling.** Paper parking of continuous forms makes it easy to switch between continuous forms and single sheets. For automatic feeding of single sheets, an optional cut sheet feeder is available.
- **Color model.** Provides seven-color printing if supported by your software.
- **Maintenance-free.** Periodic cleaning and changing the ribbon cartridge are all that's required.

OPTIONS

Options available for your printer are listed below. For detailed information on options, see Chapter 8.

- Cut sheet feeder (To complement your feeder, a double bin adapter and an envelope adapter are also available.)
- Font cards
- Emulation cards
- Serial interface board
- Color kit

SETTING UP

Your new printer is easy to install and set up. This chapter tells you how to set up the printer and get started printing right away. If this is your first dot matrix printer, we recommend reading the entire chapter from start to finish, following all of the steps. In this chapter you will learn how to:

- Position, unpack, and assemble the printer
- Identify the printer's major components
- Connect the power and interface cables
- Test the printer before connecting your computer
- Select an emulation and print using your software

If you have a problem setting up the printer, review the problems and solutions listed in Chapter 7. If the problem persists, contact your dealer.

SELECTING A GOOD LOCATION

This printer is suitable for most business, office, and home environments. To obtain peak performance from the printer, select a location that meets the following guidelines.

- √ Place the printer on a sturdy, level surface.
- √ Place the printer near a well-grounded AC power outlet.
- √ To ensure easy access to the front and rear of the printer, leave several inches of space around the printer. Do not block the air vents on the sides and rear of the printer.
- √ Do not place the printer in direct sunlight or near heaters.
- √ Be sure the room is well-ventilated and free of excessive dust.
- √ Do not expose the printer to extremes of temperature and humidity.
- √ Use the power cord supplied with the printer. Do not use an extension cord.

- √ Do not plug the printer into a power outlet that is shared with heavy industrial equipment (such as motors) or appliances (such as copiers or coffee makers). Such equipment often emits electrical noise or causes power degradation.

UNPACKING

Unpack your printer as follows:

1. Open the carton and remove the printer and its components. Be sure you have all of the items shown below.

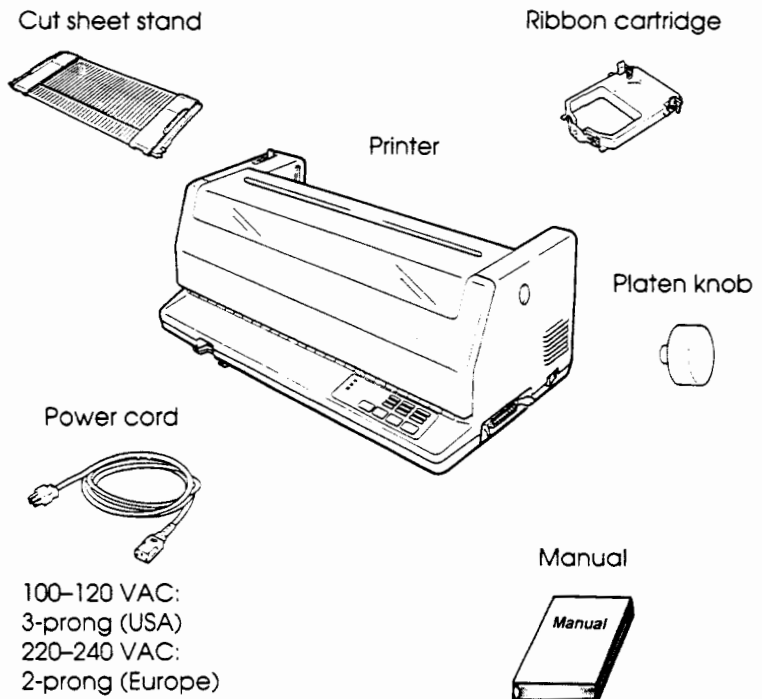

Checking items received

2. Carefully examine each item for damage. Report any damage to your dealer or shipping agent.

3. Place the printer where you plan to use it.
4. Remove the tape securing the top and front covers of the printer. Open the covers and remove the cardboard shipping restraint which holds the print head carriage in place.

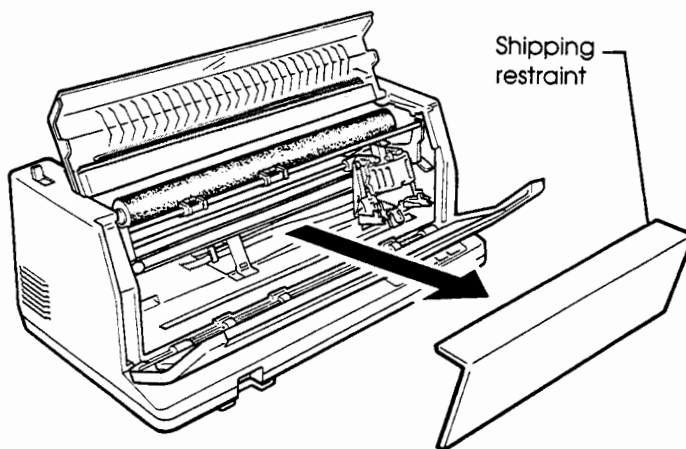

Removing the shipping restraint

5. Store the original shipping carton and packaging materials. The original packaging is ideal for moving or shipping your printer to another location.

NOTE

You must supply the interface cable. It is not shipped with the printer.

Checking Options and Consumables

The following options and consumables are shipped in separate packages:

- Cut sheet feeder
- Double bin adapter

- Envelope adapter
- Font cards
- Emulation cards
- Ribbon cartridges

If you ordered any of these items, check that you received them. To install options, see Chapter 8.

Once you're sure you have everything, you're ready to assemble the printer.

ASSEMBLING THE PRINTER

In this section you will install the platen knob, cut sheet stand, and ribbon cartridge.

Installing the Platen Knob

Referring to the following figure, fit the groove on the platen knob over the same-sized groove on the right side of the printer.

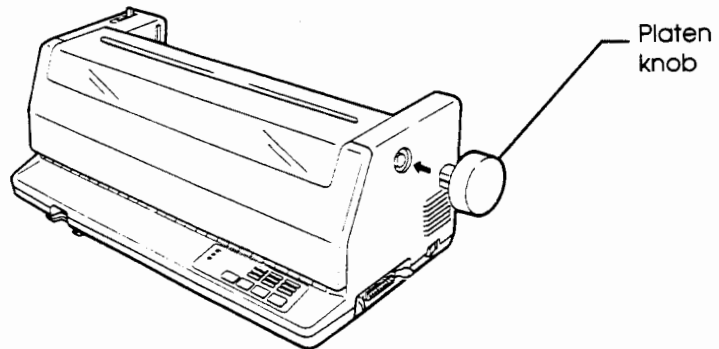

Installing the platen knob

Installing the Cut Sheet Stand

The cut sheet stand allows smooth feeding of both single sheets and continuous forms. To install the cut sheet stand:

1. Referring to the following figure, locate the two grooved notches on top of the printer and behind the top cover. Note that each notch has a front groove and a rear groove.

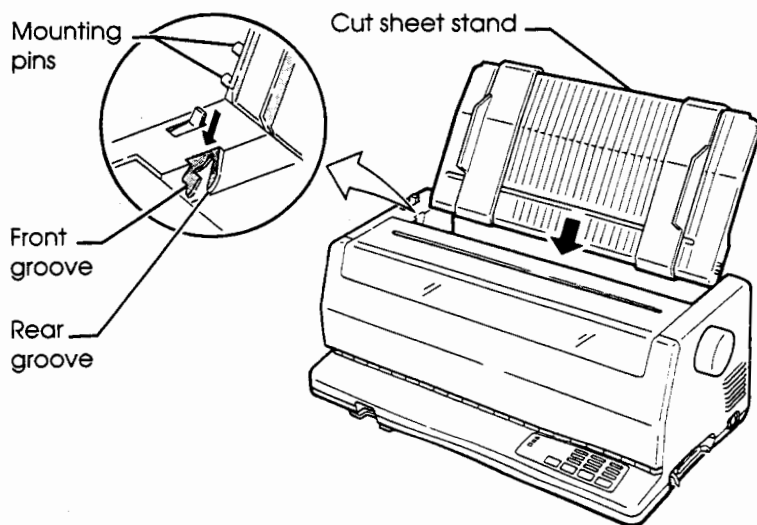

Installing the cut sheet stand

2. Locate the two mounting pins on each side of the cut sheet stand.
3. Tilt the cut sheet stand at an angle over the top of the printer. Slide the cut sheet stand's mounting pins into the long, front grooves of the notches. This is the cut sheet stand's *up* position, used for printing on single sheets.

To rotate the cut sheet stand *down*, grasp it by the sides and lift up until the two upper mounting pins fall into the rear grooves of the notches. This is the position used for printing on most continuous forms paper.

Installing the Ribbon Cartridge

A color printer can use either color or black ribbon cartridges. A monochrome printer *requires* a black ribbon cartridge. To install the ribbon cartridge:

1. Open the top and front covers of the printer. For easy access to the print head carriage, slide it about three quarters of the way to the right side of the platen.
2. Inside the right side of the printer, locate the paper thickness lever, shown in the following figure. The paper thickness lever has three positions: up, middle, and down. Move the paper thickness lever to the *down* position.

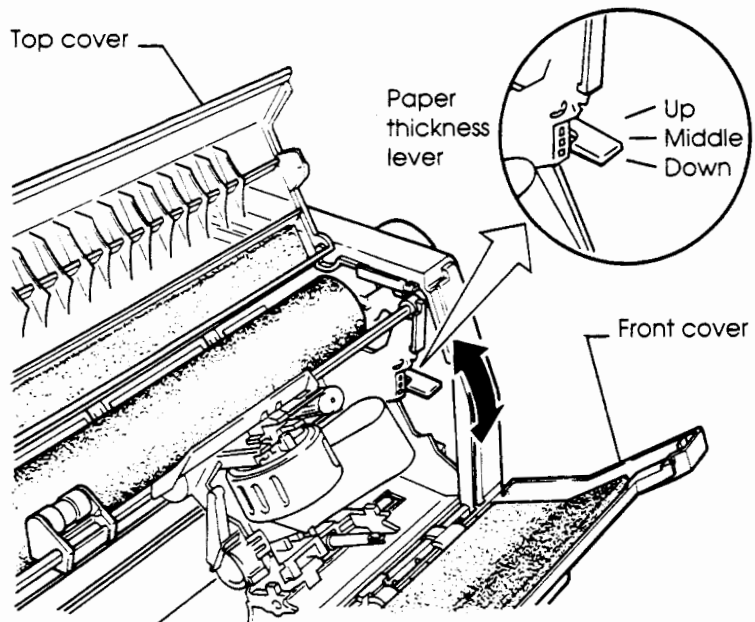

Preparing to install the ribbon

3. Remove the ribbon cartridge from its package. If the ribbon is color, remove the red stopper releasing the ribbon feed knob (see the following figure). Turn the ribbon feed knob COUNTERCLOCKWISE to be sure it feeds properly.

NOTE

If using a black ribbon, do not remove the small strip of plastic covering the ribbon. This is the *ribbon mask*, used to protect the ribbon.

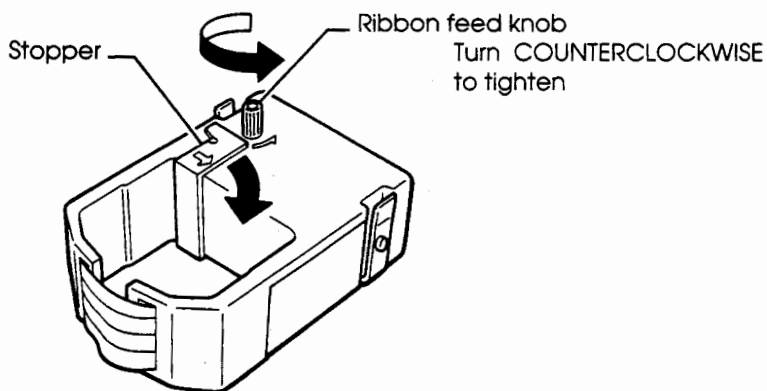
**Preparing the ribbon cartridge**

4. On either side of the ribbon cartridge, locate the two ribbon release levers, each of which has a mounting pin on the side. Referring to the following figure, place the mounting pins onto the ribbon support studs inside the printer. Rotate the cartridge so the ribbon falls between the nose of the print head and the plastic print guide.

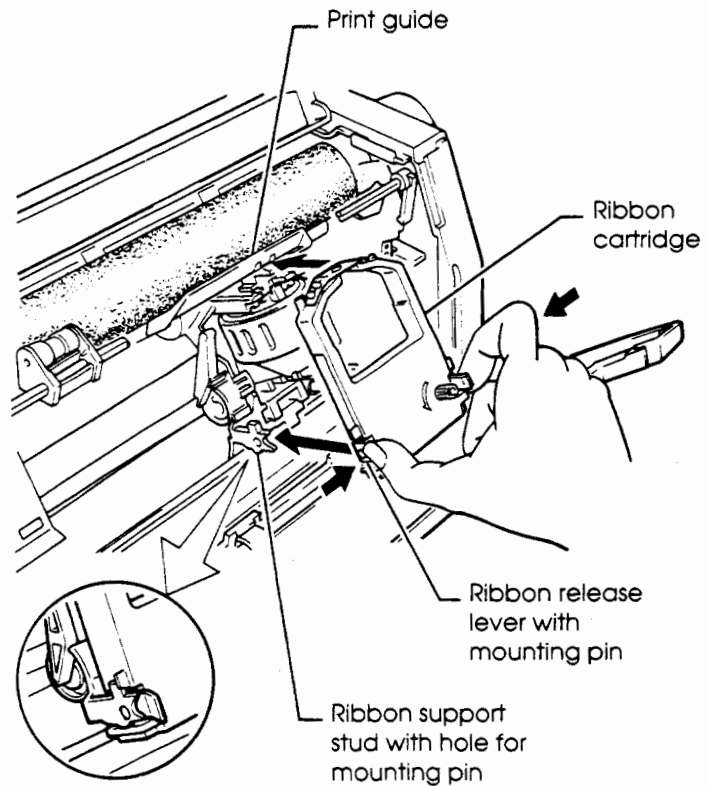

Installing the ribbon cartridge

5. Press in the ribbon release levers until the mounting pins snap into the holes on the ribbon support studs. Gently pull on the cartridge to verify that the pins are securely installed in the holes.
6. Turn the ribbon feed knob **COUNTERCLOCKWISE** to tighten the ribbon.
7. Move the paper thickness lever (inside the right side of the printer) back to the *up* position. This is the correct setting for most single sheet printing.
8. Close the front and top covers of the printer.

GETTING ACQUAINTED WITH YOUR PRINTER

Now that your printer is assembled, take a moment to become familiar with its major components.

Looking at the printer from the front and right side, you can see the components shown in the figure below.

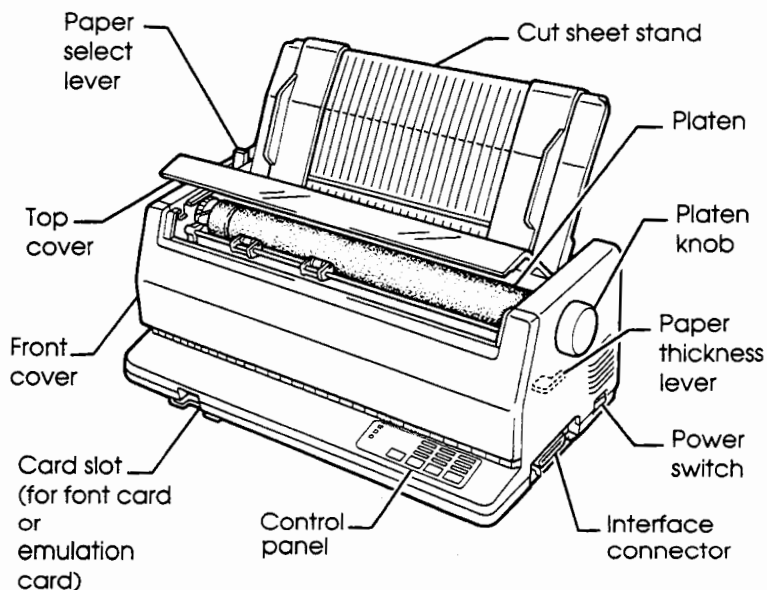

Front and side view of printer

The printer's control panel contains the buttons and indicators used to load and feed paper (see Chapter 3) and select print features (see Chapter 4). The control panel also allows you to change the printer's optional settings (see Chapter 5).

Looking at the printer from the rear, you can see the following components:

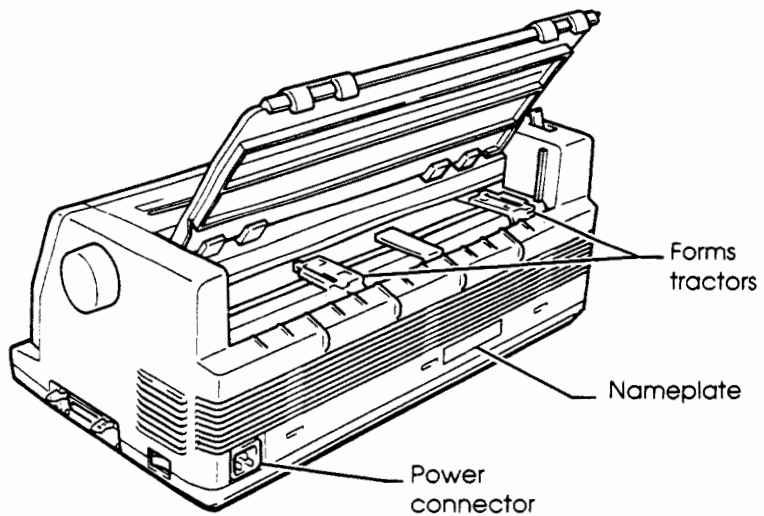

Rear view of printer

CONNECTING THE POWER CORD

Before you plug in the printer:

- ✓ Be sure the printer power is switched off. The "0" on the rear of the power switch should be visible.
- ✓ Be sure your power outlet is properly grounded.
- ✓ Be sure you have the power cord shipped with the printer. This cord is designed to minimize radio frequency interference.

To plug in the power cord:

1. Plug one end of the power cord into the power connector at the right rear of the printer.
2. Plug the other end of the power cord into your power outlet.

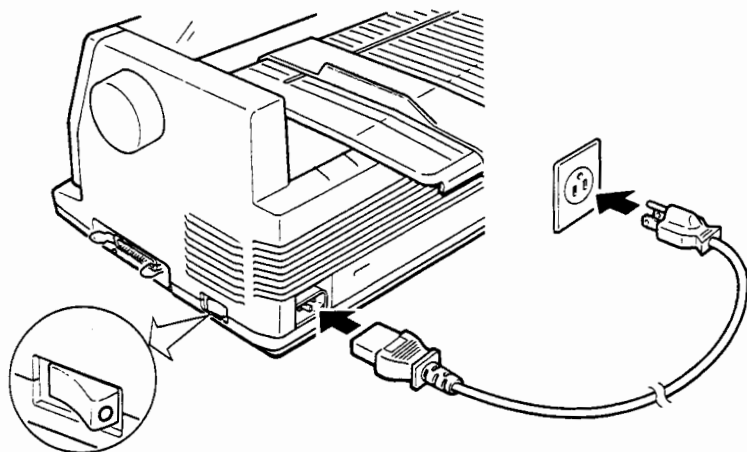

Connecting the power cord

3. Make sure the power cord is securely connected.
4. To turn on the power, press down the rear of the power switch. The "1" on the front of the switch will be visible. Within a couple seconds, the POWER indicator on the printer's control panel will turn green, the print head will move to its home position, and the ONLINE indicator will turn green.

NOTE

If the printer beeps and the PAPER OUT indicator turns red, it indicates that the paper select lever is set to the forward (continuous forms) position but no forms paper is loaded. When you move the paper select lever to the rear (single sheet) position, as described in the next section, PAPER OUT will turn off.

TESTING THE PRINTER (OFFLINE)

Now you're ready to load a piece of paper and run the printer's self-test. By running the self-test, you can check the printer's performance and print quality before you connect it to your computer.

Loading Paper for the Self-Test

To print the self-test, use paper greater than 215.9 mm (8-1/2 inches) in width to avoid printing on the platen. Standard letter or A4 size paper can be used by inserting the paper *lengthwise*.

To load a sheet of paper, check that the printer is turned on. Then do the following:

1. Make sure the paper thickness lever (inside the right side of the printer) is set to the *up* position. Make sure the paper select lever (on the top left side of the printer) is set to the rear, as shown in the following figure.

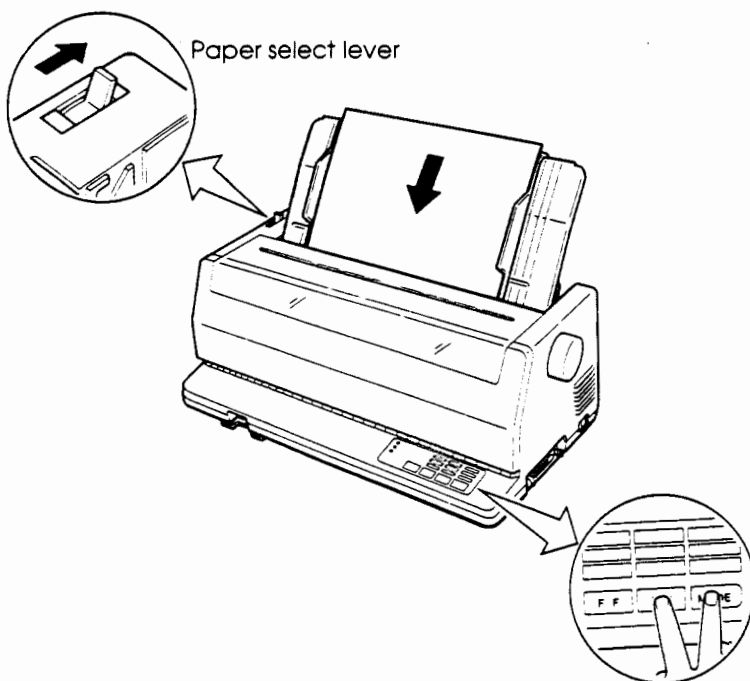

Loading a sheet of paper

2. Raise the cut sheet stand. Move the left paper guide all the way to the right. Insert a piece of paper into the cut sheet stand. If using paper of letter or A4 size, insert the paper *lengthwise* to avoid printing on the platen.

CAUTION

Printing on the platen will damage the platen and print head.

Adjust the right paper guide so that the paper lies flat on the cut sheet stand.

3. Simultaneously press the MODE and LF buttons. The paper will be loaded to the top-of-form position.

Top-of-form is the base used by the printer to calculate the top margin of the page. The possible top-of-form settings are 25.4 mm (1 inch), which is the factory setting, or 4.2 mm (1/6 inch). The total top margin of your page is the sum of the following settings: top-of-form, the top margin specified in your software, and the top margin specified in the printer's setup mode. See Chapter 5 for information on changing the top-of-form or top margin settings.

Printing the Self-Test

The printer has a built-in self-test program. The self-test prints the firmware version, the names of the printer's resident emulations, and all of the characters available in the emulations. The self-test prints 80 characters per line. If you are using a color printer and ribbon, printing is in seven colors.

Be sure a piece of paper is loaded. Then follow these steps to print a self-test page.

1. Turn off the printer.

2. While pressing the FF button, turn the printer back on. Continue pressing FF until the printer beeps. Self-test printing will start.

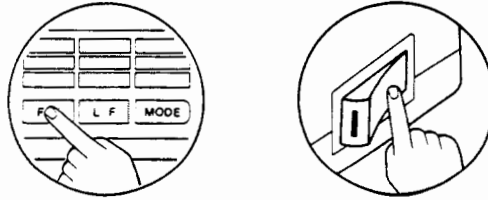

Starting the self-test

3. Allow printing to continue for about 15 seconds. To stop printing, press the LF or MODE button. Manually turn the platen knob clockwise to remove the test page.

NOTE

Do not try to use the FF (form feed) button to eject the paper. In self-test mode, FF cannot be used to feed paper forward.

4. Look at the self-test page. It should look similar to the sample on the opposite page.

Check that printing is uniform, without light, dark, or smudged areas. If the print quality is good, go to step 5. Otherwise, try to correct the problem using these steps:

- Be sure the ribbon is installed correctly.
- Be sure the paper thickness lever is set to the *up* position.
- Insert a new sheet of paper into the cut sheet stand. Turn the platen knob to manually advance the paper until the top edge has moved past the paper bail rollers.
- Press LF or MODE to restart printing. If the print quality remains poor, turn off the printer and contact your dealer for assistance.

NOTE

The printer is able to print a special "demo pattern" illustrating some of the printer's capabilities. To print the demo pattern, shown in the figure below, take the following steps:

- Load a sheet of letter or A4 size paper. Turn off the printer.
- While pressing the LF button, turn the printer back on. The printer will start printing the demo pattern.
- To stop the demo, press ONLINE. To restart the demo, press ONLINE again.
- To exit demo mode, turn off the printer.

```

**** PRINTER FUNCTION SPECIFICATION ****

Printing technology: 24 wire dot matrix. Logic seeking
Resolution: Letter quality - 360 X 180 dots/inch
              Draft quality - 120 X 180 dots/inch
              (Print speed: 100 cps, 180 cps, 300 cps, 480 cps)

Color (Option): 7 colors: Black, Magenta, Cyan,
                Violet, Yellow, Orange, and Green

Standard command set: Fujitsu DPL24C PLUS Version 1.03
Resident emulations: Epson Lq2500, Lq2550, IBM Proprinter XL24
Emulation cards (option): Fujitsu DPL24D/ Diablo 630API, DEC LA50/75/120/210
Character sets: Codepage 437, 850, 860, 863, 865, ISO8859-1
                11 national sets, 357 characters per font

Print functions: See below.

Fonts - Courier 10, Pica 10, Prestige 12, Boldface PS
        Condensed, Correspondence 10, Draft 10
        Font card No0, Font card No1, Font card No2, Font card No3

Bold printing Shadow printing Italic printing Underline
Condensed: Superscript Subscript

Double width Double height Double W & H

(The following functions are for the DPL24C PLUS only)

Underline TYPE 1 TYPE 2 TYPE 3 TYPE 4 TYPE 5 TYPE 6 Overline

Bar code print: Codabar, EAN8, EAN13, Code 3 of 9, Industrial 2 of 5
                Interleaved 2 of 5, Matrix 2 of 5, UPC type A

EAN8 example:



Multiwidth & height - Screened outline:

FOR TITLE
    
```

Demo pattern

CONNECTING THE PRINTER TO YOUR COMPUTER

Your printer has either a Centronics parallel or RS-232C serial interface. The parallel interface is factory-installed. The serial interface is available as a separate option (see Chapter 8 for installation instructions). Cables for either type of interface are available from dealers, cable manufacturers, and other suppliers. For detailed interface specifications, see Appendix D.

Selecting a Parallel Interface Cable

Obtain a parallel interface cable meeting the following specifications:

- √ At the printer end, use a shielded male Centronics connector such as an Amphenol DDK 57FE-30360 or its equivalent. To prevent RFI (radio frequency interference), the connector cover must be connected to the cable shield.
- √ At the computer end, most computers (including IBM PCs) require a male DB-25P connector, but some computers require a Centronics connector. To determine the type of connector your computer uses, refer to your computer's user manual.
- √ Be sure the length of the cable does not exceed 3 meters (10 feet).

Selecting a Serial Interface Cable

Obtain a serial interface cable meeting the following specifications:

- √ At the printer end, use a 25-pin male connector such as a Cannon DB-25P or its equivalent.
- √ To determine the type of connector your computer requires, refer to your computer's user manual or ask your dealer.
- √ The length of the cable can be up to 15 meters (50 feet). This length cable is required in many networking and shared-printer configurations.

Connecting the Interface Cable

To connect the interface cable:

1. Turn off both the printer and the computer.
2. Attach the interface cable to the connector on the right side of the printer. See the following figure.

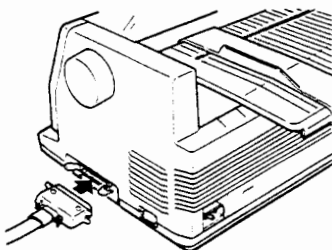

Parallel interface

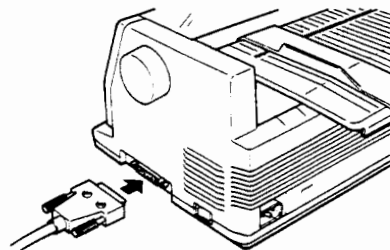

Serial interface

Connecting the interface cable

3. To secure a parallel interface cable, flip the fastener clips on the printer into the notches on the cable connector. To secure a serial interface cable, tighten the screws in the cable connector.
4. Attach the other end of the cable to your computer. Gently pull on the cable to verify it is secure.

SELECTING AN EMULATION

Before printing with your software, you must verify that the correct emulation is selected on your printer. This section explains what emulations are and how to select the emulation you require.

For Experienced Users:

The printer's preselected factory setting is the Fujitsu DPL24C PLUS emulation. If this is the emulation you require, you may skip this section.

An emulation is a set of commands used by your software to communicate with the printer. There are many different emulations available for printers. Each emulation has its own unique features and capabilities. This printer offers four *resident* emulations:

- Fujitsu DPL24C PLUS (for Fujitsu DL-series printers)
- IBM Proprinter XL24
- Epson LQ-2500
- Epson LQ-2550

(Resident emulations are contained in the printer's permanent memory instead of on removable emulation cards.) Additional emulations are also available on emulation cards (see Chapter 8).

Here are some pointers to help you determine which emulation to select:

- √ Determine which emulations your software supports. Refer to your software documentation.
- √ If you are using more than one software package, determine which emulation is supported by the software you use most frequently. That's the emulation you should select on the printer.
- √ If more than one emulation is supported by your software, select the DPL24C PLUS emulation if possible. This is the emulation with the greatest capabilities.
- √ If you want to use an emulation not supported by your software, contact your software manufacturer or printer supplier and ask whether support is available. For example, you may be able to obtain a printer driver not shipped with the original software package.

To select an emulation, follow these steps.

1. Turn on the printer and load a sheet of paper.

To change a single printer setting such as the emulation, you can use single sheet paper. To change several printer settings as described in Chapter 5, however, you must load continuous forms paper. See Chapter 3 for paper loading instructions.

2. Enter setup mode.

Turn the printer off. While pressing the MODE button, turn the printer back on. Continue pressing MODE until the printer beeps.

If you don't hear a beep and the printer goes online, you are not in setup mode. Turn off the power and try again. Make sure you press MODE until the printer beeps.

The printer enters offline setup mode and prints the following information.

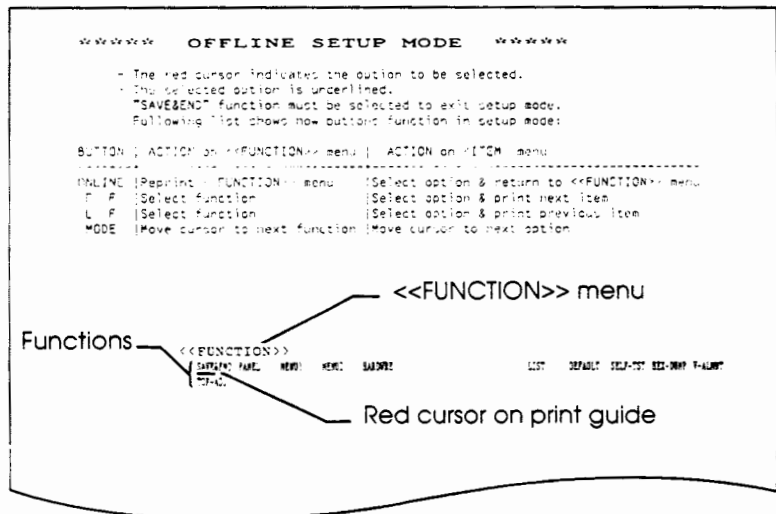

Initial printout in setup mode

Check that the <<FUNCTION>> menu (shown in the previous figure) is printed at the bottom of the page.

3. Select the MENU1 function.

Look for the red cursor on the plastic print guide. Initially, it should be positioned below SAVE&END at the beginning of the <<FUNCTION>> menu. Repeatedly press MODE to position the red cursor beneath MENU1, as shown below:

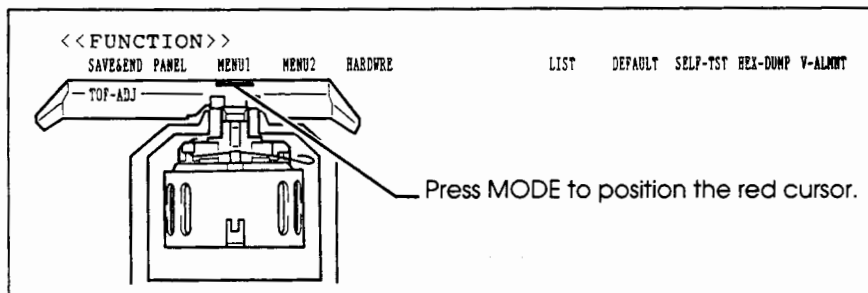

Press FF to underline (select) MENU1 and print the <EMULATE> options:

```
< EMULATE >      DPL24C+  IBMXL24      LQ2500  LQ2550
```

The currently selected emulation is indicated by a short underline. In the figure above, the Fujitsu DPL24C PLUS emulation is selected.

4. Select an emulation.

Repeatedly press MODE to position the cursor beneath the emulation you require. Press FF to underline (select) the emulation and print the next MENU1 item.

5. Exit MENU1.

Press ONLINE to exit the MENU1 function and reprint the <<FUNCTION>> menu.

6. Exit setup mode, saving the emulation.

To exit setup mode and save the new emulation, check that the red cursor is positioned beneath SAVE&END. Press FF. The printer will underline (select) SAVE&END and return online.

To change other printer settings using setup mode, see Chapter 5.

PRINTING A SAMPLE PAGE (ONLINE)

You have used the printer's self-test to verify that the printer hardware functions correctly. Now you're ready to try printing using one of your software packages. This will tell you whether the printer is correctly connected to your computer.

If you are using a parallel interface, the printer will usually print the correct characters. You may need to adjust the page layout or various print features using your software or the printer's setup mode. If you are using a serial interface, it's possible the printer will not work at all, or it will print a lot of "?" characters. This means that the serial settings on the printer do not match those on your computer or in your software. Before changing these settings, use the following procedure to try printing using the printer's preselected factory settings.

To test communication between the printer and computer, follow these steps.

1. Load a piece of paper.
2. Check that the printer is online. The ONLINE indicator should be green. If it isn't, press the ONLINE button.
3. Try to print using your word processor, a programming language, or other software.
4. If the page layout or other print features are wrong, use your software's printer selection menus or the the printer's setup mode, described in Chapter 5, to make the changes you require.

If the printer does not print or prints the wrong characters, take the following steps:

- Check that the interface cable is properly connected.
- Check that the printer emulation selected in your software is the same as the emulation selected on the printer.
- If using a serial interface, check that the printer's serial interface settings are the same as those on the computer. The printer's preselected factory settings are: 8 data bits, no parity, 1 stop bit, 9600 baud, and XON/XOFF protocol.

You can change the serial settings on either the printer or your computer. To change the printer's settings, see Chapter 5. To change the computer's settings, use the selection menus provided by your software or the commands provided by your computer's operating system. An example using the MS-DOS operating system is given below. If the printer still doesn't work, consult your dealer or someone experienced in serial interface communications.

Using MS-DOS to Specify Serial Interface Settings

For an IBM PC or compatible, the following MS-DOS MODE commands will set the computer's serial settings to match the printer's factory settings:

```
MODE COM1:9600,N,8,1,P  
MODE LPT1:=COM1
```

To activate these settings whenever you turn the computer on, include the MODE commands in your AUTOEXEC.BAT file. Make sure the MODE.COM file is included in your root directory.

You are now finished setting up and testing the printer. To familiarize yourself with everyday printer operations such as loading paper, selecting print features, and printing, see Chapters 3 and 4.

LOADING AND USING PAPER

This chapter explains how your printer uses paper. Topics are covered in this order:

- Selecting paper
- Overview of paper operations
- Adjusting for paper thickness
- Using single sheets
- Using continuous forms
- Feeding paper
- Switching paper types

Tips for handling paper are given at the end of the chapter. If you are using multi-part forms, envelopes, or labels, check this section.

SELECTING PAPER

The printer can handle either single sheets of paper or continuous forms. Single sheets, sometimes called cut sheets, include sheets of paper, envelopes, and non-continuous multi-part forms. Continuous forms include paper, labels, and multi-part forms fed into the printer using the rear forms tractors.

For best results, be sure your paper meets the specifications below. See Appendix B for detailed specifications.

Length	Single sheets: 76 to 364 mm (3 to 14.3 inches) Continuous forms: 102 mm (4 inches) or greater
Width	102 to 330 mm (4 to 13 inches)
Thickness	0.3 mm (.012 inch) maximum total thickness. For envelopes, the maximum thickness of the multi-layer part can be up to 0.5 mm (0.02 inch).
Copies	1 to 4 copies, including the original. For carbon-interleaved paper, the carbon counts as a copy.

OVERVIEW OF PAPER OPERATIONS

The following levers and buttons are used to handle paper in your printer:

- Paper select lever, located on the top left corner of the printer
- Paper thickness lever, located inside the front cover on the right side of the printer
- FF, LF, and MODE buttons on the control panel

The figure below shows the location of each lever and button.

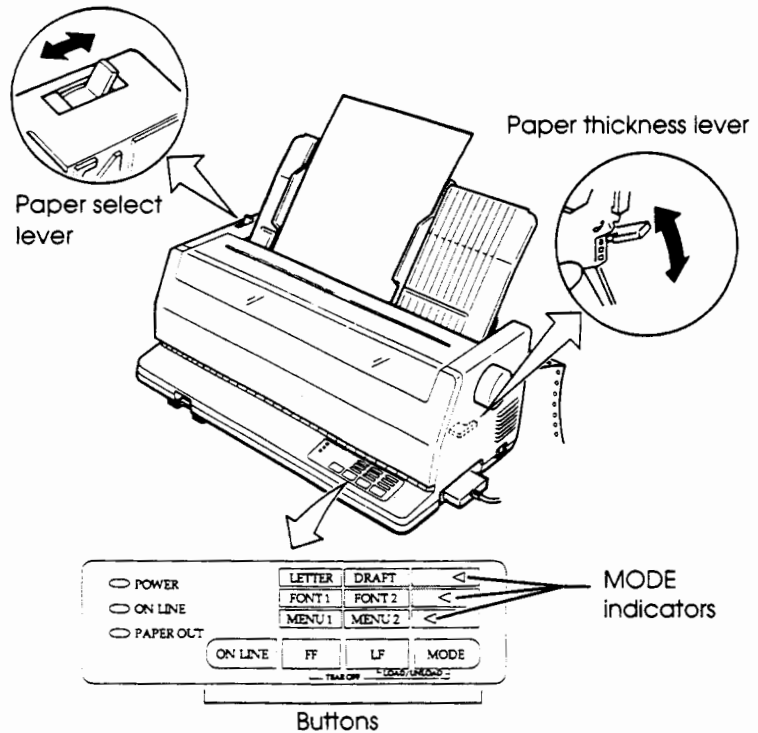

Printer levers and buttons

Table 3.1 summarizes how the levers and buttons are used to handle paper. For detailed information, see the other sections in this chapter.

NOTE

To load and advance paper, the **MODE** indicators must be off.
To turn the **MODE** indicators off, repeatedly press the **MODE** button until none of the indicators is lit.

Table 3.1 Levers and Buttons Used to Handle Paper

Lever/Button	Purpose	What You Do
FF	Form feed Load paper (with PAPER OUT lit)	Press FF to execute a form feed. Continuous forms are fed forward by one page. Single sheets are ejected. If PAPER OUT is lit, press FF to load paper.
LF	Line feed	Press LF to feed paper forward by one line.
MODE + FF	Advance forms for tear-off	Simultaneously press MODE and FF to advance forms to the tear-off edge. Tear off the forms, then press any button to retract the forms.
MODE + LF	Load/unload paper	Simultaneously press MODE and LF to load paper, or to unload (retract) continuous forms to the park position. NOTE: When PAPER OUT is lit, an alternate way to load paper is by pressing FF.
Paper select lever	Select the paper path	Move the paper select lever to the rear for single sheets (cut sheet stand or feeder). Move the paper select lever forward for continuous forms.
Paper thickness lever	Adjust for paper thickness or number of copies	Move the paper thickness lever to the up, middle, or down position. Use <i>up</i> for 1 to 2 copies (including original). Use <i>middle</i> for 2 to 4 copies (including original). Use <i>down</i> for envelopes or labels.

ADJUSTING FOR PAPER THICKNESS

The printer can handle paper of different thicknesses. This includes multi-part forms with up to four parts (original plus three copies). For detailed paper thickness specifications, see Appendix B.

The paper thickness lever, located inside the front cover on the right side of the printer, allows you to adjust for different paper thicknesses. Be sure to adjust the paper thickness lever whenever you change the number of copies being printed.

To adjust the paper thickness lever:

1. Open the top and front covers of the printer.

CAUTION

Print head may be hot if you've been printing recently.

2. Locate the paper thickness lever, shown in the figure below.

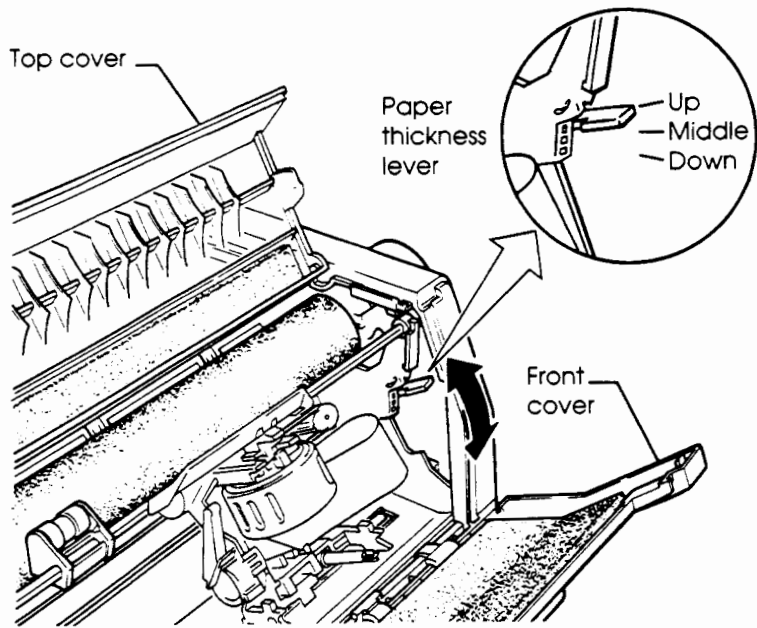

Adjusting the paper thickness lever

3. The paper thickness lever has three positions: up, middle, and down. Use the following table to determine the appropriate setting for your paper. Move the paper thickness lever to the appropriate position.

Table 3.2 Paper Thickness Lever Settings

Number of Copies (Including Original)*	Position
1 copy	Up
2 copies	Up or middle
3 to 4 copies	Middle
Labels, envelopes Ribbon replacement	Down

* For carbon-interleaved paper, the carbon counts as one copy.

USING SINGLE SHEETS

This section explains how to load paper in the cut sheet stand or cut sheet feeder. The cut sheet stand allows paper to be loaded manually one sheet at a time. A cut sheet feeder allows paper to be automatically loaded from a stack.

Loading a Single Sheet of Paper

To load a sheet of paper into the cut sheet stand:

1. Make sure the printer is turned on. Check that continuous forms are retracted to the park position (see **Unloading Continuous Forms** later in this chapter for details).
2. If necessary, re-adjust the paper thickness lever (see **Adjusting for Paper Thickness** earlier in this chapter).

3. Move the paper select lever (on the top left side of the printer) to the rear.
4. Raise the cut sheet stand to the *up* position. Position the left paper guide.

NOTE

When the left paper guide is positioned all the way to the right, you will obtain a left margin of 11 mm (7/16) inch, plus the left margin specified using your software or the printer's setup mode. To help align the paper guide, use the two inch-based rulers on the top cover of the printer. The 110-column ruler (upper ruler) shows 10 columns per inch. The 130-column ruler (lower ruler) shows 12 columns per inch.

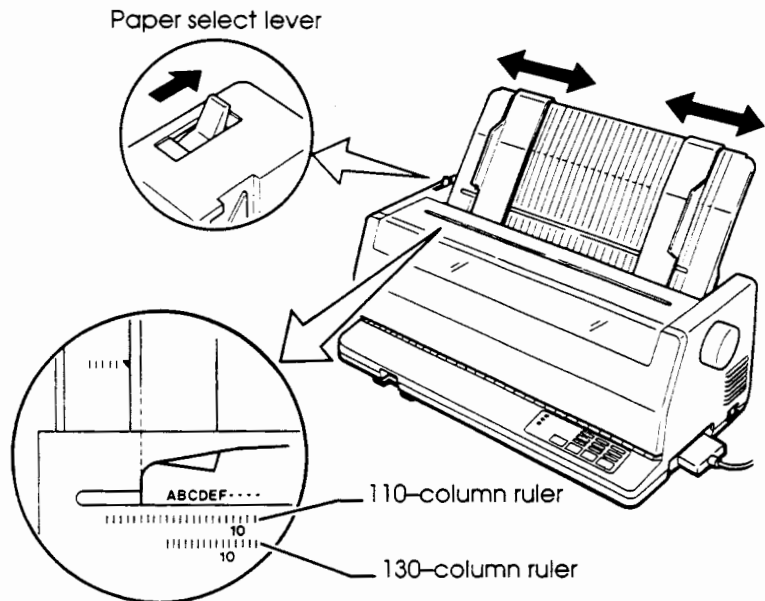

Preparing to load a sheet of paper

5. Insert a sheet of paper into the cut sheet stand. Be sure the bottom edge of the paper snugly engages with the platen. Adjust the right paper guide.

6. If any of the MODE indicators is lit, repeatedly press MODE to turn the indicators off. Simultaneously press the MODE and LF buttons. The paper will advance to the top-of-form position. Top-of-form is the first line on which printing can start. To adjust the position of the paper slightly, manually turn the platen knob.

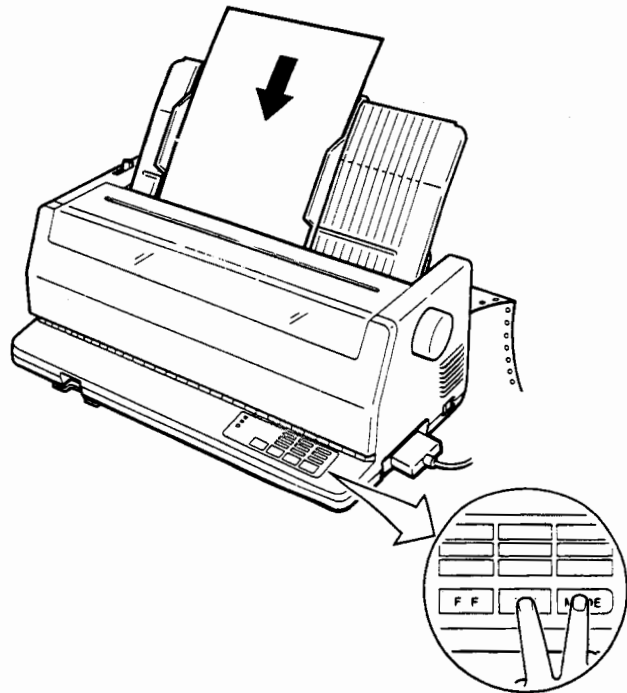

Loading a sheet of paper

7. Place the printer online. Print a sample page and check the margins of the page. If necessary, adjust the following:
 - Horizontal alignment of the paper. Re-adjust the paper guides if required.
 - Top-of-form setting (see Chapter 5)
 - Margin settings. Use your software or the printer's setup mode (see Chapter 5).

Loading Paper in the Cut Sheet Feeder

A cut sheet feeder allows you to automatically print on single sheets without inserting the sheets one by one. This can save you a lot of time when printing long files using single sheets. See Chapter 8 for more information on cut sheet feeders.

To load paper in the cut sheet feeder:

1. Make sure the printer is turned on. Check that continuous forms are retracted to the park position (see **Unloading Continuous Forms** later in this chapter for details).
2. If necessary, re-adjust the paper thickness lever (see **Adjusting for Paper Thickness** earlier in this chapter).
3. Move the paper select lever (on the top left side of the printer) to the rear.
4. Referring to the figure below, prepare the cut sheet feeder as follows:

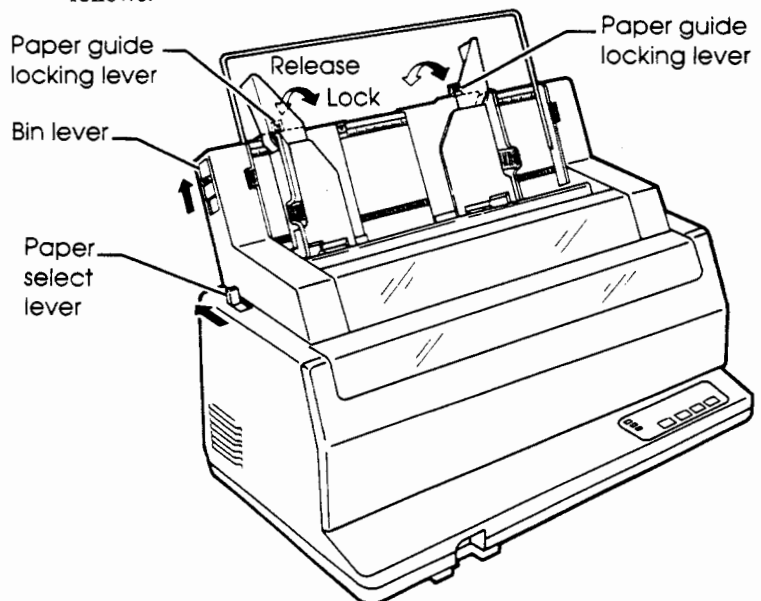

Preparing the cut sheet feeder

- To open the paper bin, push the bin lever up to "OPEN." The bin lever is located on the left side of the feeder.
- Push back both of the paper guide locking levers.
- Position the left paper guide. Pull the left locking lever forward to secure the left paper guide.

NOTES

- To help align the left paper guide, use the inch-based ruler located behind the paper guides. The ruler is subdivided into 10 columns per inch. Setting the left paper guide 12.7 mm (1/2 inch) from the left will provide a left margin of 6.3 mm (1/4 inch), plus the left margin specified using your software or the printer's setup mode.
- The vertical mark near the base of the left paper guide, shown in the figure below, indicates the location of the printer's paper-out sensor (the groove on the left side of the platen). Do not position the left paper guide to the right of this vertical mark, as your paper will not load properly.

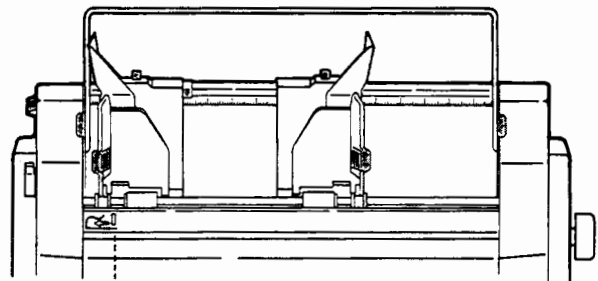

Make sure the left edge of your paper falls within this area.

- Slide the right paper guide to the approximate width of your paper.

5. Manually fan the stack of paper and place it in the paper bin. See the following figure.

NOTE

A short vertical mark inside each paper guide indicates the maximum capacity of the bin. Be sure your paper stack does not exceed these vertical marks.

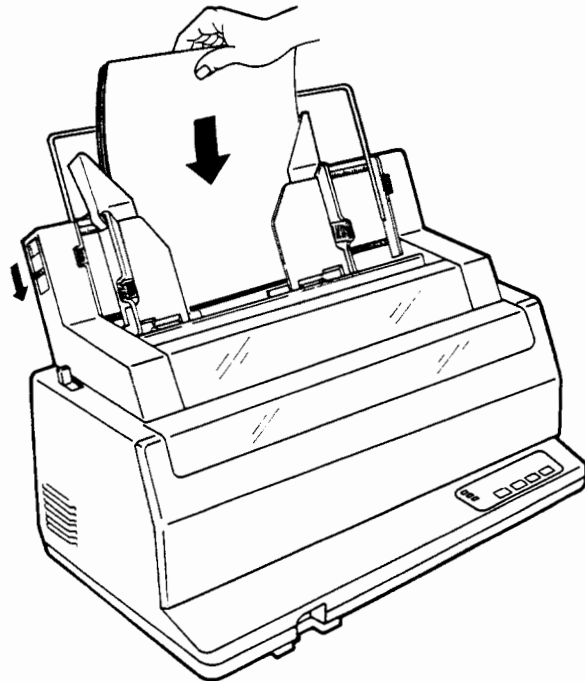

Loading the cut sheet feeder

6. Re-adjust the right paper guide, leaving a slight gap between the paper guide and the right edge of the paper. About 1.5 mm (1/16 inch) is sufficient. Pull the right locking lever forward.
7. Push the bin lever down to "CLOSED."

8. To load paper to the top-of-form position, use one of the following methods:

- Load the paper *manually*. If any of the MODE indicators is lit, repeatedly press MODE to turn the indicators off. Simultaneously press the MODE and LF buttons. The paper will advance to the top-of-form position. To adjust the position of the paper slightly, manually turn the platen knob.
- Load the paper *using software*. Place the printer online. Load paper according to the instructions in your software documentation. Most software packages will automatically load paper for printing.

9. Place the printer online. Print a sample page and check the margins of the page. If necessary, adjust the following:

- Horizontal alignment of the paper stack. Re-adjust the paper guides if required.
- Top-of-form setting (see Chapter 5)
- Margin settings. Use your software or the printer's setup mode (see Chapter 5).

Ejecting Single Sheets

If you print using software, each sheet is automatically ejected when the end of the printed page is reached. To manually eject sheets of paper, use one of the following methods:

- Execute a forward form feed. (With the MODE indicators off, press FF.)
- Turn the platen knob clockwise.

USING CONTINUOUS FORMS

Continuous forms paper, fanfolded at the horizontal perforations, is fed into the printer using the rear forms tractors. Forms paper is ideal for printing rough drafts and long files.

Positioning the Paper Stack

Place the stack of forms paper directly below the rear of the printer. After the paper is installed in the printer, the paper path will look like this:

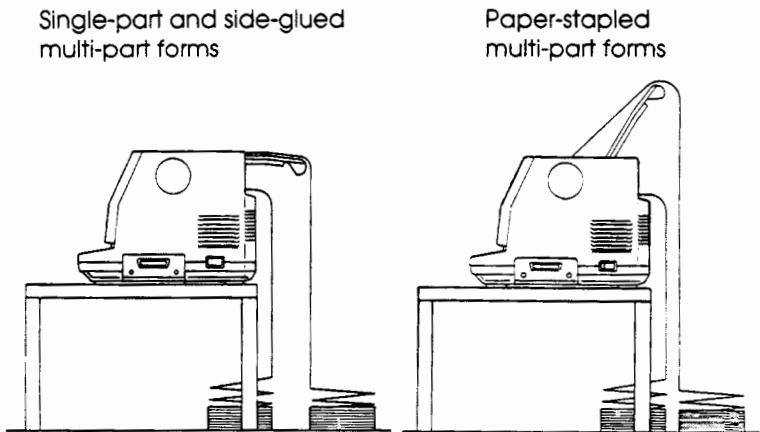

Placement of continuous forms

Loading Continuous Forms

If you have a cut sheet feeder installed, you must remove it to load continuous forms paper. To load forms paper:

1. Make sure the printer is turned on. Remove any single sheet paper from the printer.

2. If necessary, re-adjust the paper thickness lever (see **Adjusting for Paper Thickness** earlier in this chapter).
3. Move the paper select lever (shown below) to the forward position.

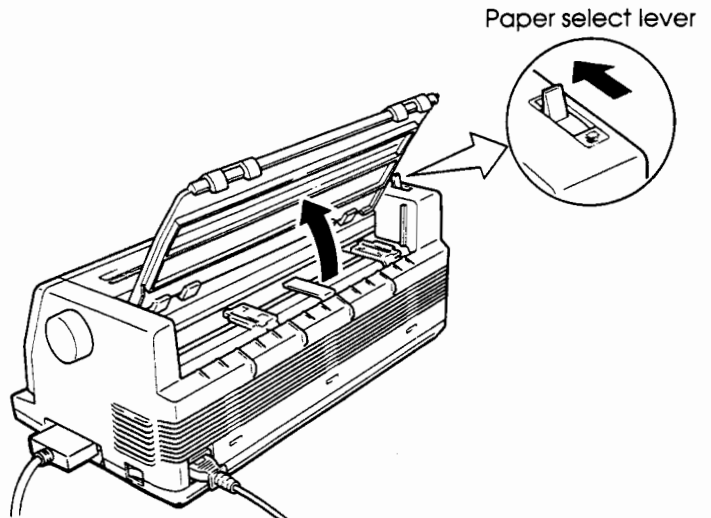

Preparing to load forms paper

4. Raise the cut sheet stand, if installed.
5. Release the tractor locking levers by pushing them toward the front of the printer. See the following figure.

CAUTION

Be careful to release the locking levers before moving the tractors. Otherwise, you may damage the levers.

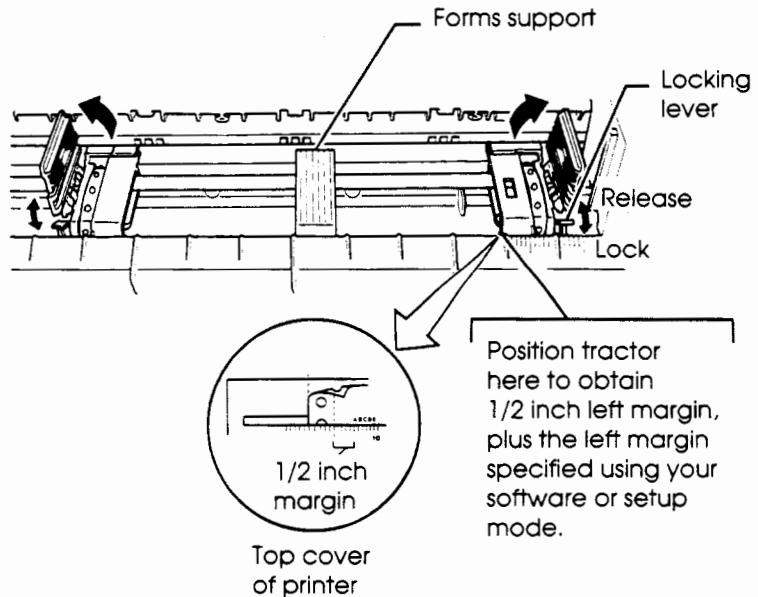

Positioning the tractors (rear view)

6. Position the right tractor (as seen from the rear of the printer). Pull the right locking lever toward the rear of the printer to secure the tractor. Center the middle forms support.

NOTE

Below the right tractor (as seen from the rear), there is a short inch-based ruler with 10-columns per inch. To obtain a left margin of 12.7 mm (1/2 inch), plus the left margin specified using your software or the printer's setup mode, position the right tractor at the beginning of the ruler. See the figure above.

7. Open the tractor paper holders and fit the form's feed holes onto the left and right tractor pins, adjusting the left tractor (as seen from the rear of the printer) to the width of the form. Close the paper holders.

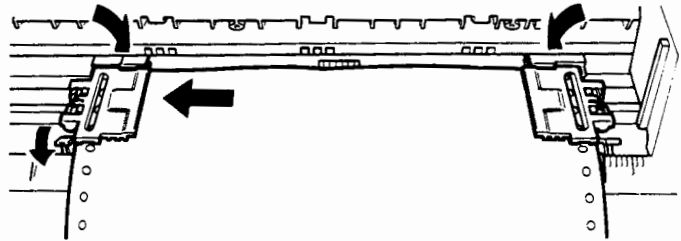

Installing forms paper (rear view)

8. Pull the left tractor (as seen from the rear) to stretch the paper taut. Pull the left locking lever to the rear to secure the tractor in place.
9. If using the cut sheet stand, raise it to the up position for paper-stapled multi-part forms. For other forms paper, lower the cut sheet stand to the down position.
10. If any of the MODE indicators is lit, repeatedly press MODE to turn the indicators off. Simultaneously press the MODE and LF buttons. The paper will advance to the top-of-form position. Top-of-form is the first line on which printing can start.
11. Place the printer online. Print a sample page and check the margins of the printed page. If necessary, adjust the following:
 - Horizontal alignment of the paper. Move the forms tractors as required.
 - Top-of-form setting (see Chapter 5)
 - Margin settings. Use your software or the printer's setup mode (see Chapter 5).

Unloading Continuous Forms

To unload continuous forms:

1. Make sure the paper select lever is set to the forward position.
2. Make sure the MODE indicators are off. Simultaneously press the MODE and LF buttons. The continuous forms will be unloaded (retracted) to the park position. If forms cannot be retracted in one operation, continue to simultaneously press MODE and LF until the paper is parked.

NOTE

The printer can retract forms a maximum of 55.8 cm (22 inches) per operation.

3. To remove the forms, raise the tractor paper holders and lift out the paper.

Tearing Off Forms

Your printer has a special “tear-off edge” that allows you to remove printed pages without wasting paper. The tear-off edge is located on the top cover. (This feature is not available if you have a cut sheet feeder installed.)

To tear off continuous forms using the tear-off edge:

1. Make sure the MODE indicators are off. Simultaneously press the MODE and FF buttons. The paper will advance to the tear-off edge.

NOTE

If the bottom perforation of your paper is not positioned at the tear-off edge, it may indicate that the length of your paper is not correctly specified in your software or the printer's setup mode. Check that the paper length is correctly specified. For information on specifying page length using setup mode, see Chapter 5.

2. Tear the paper off at the perforation.

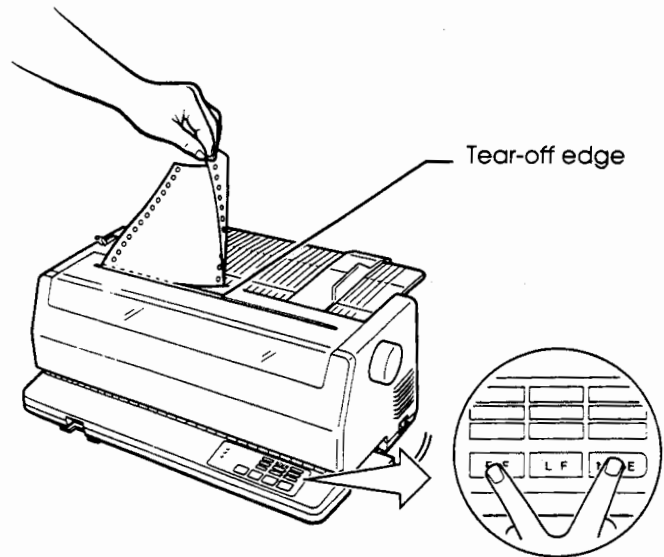

Tearing off continuous forms

3. Press any button to retract the forms back to the top-of-form position.

FEEDING PAPER

Using the FF and LF buttons on the printer's control panel, you can feed paper forward by the page or the line. The printer can be either online or offline. Feeding paper by the page is sometimes called "executing a form feed." Feeding paper by the line is sometimes called "executing a line feed."

The printer does not allow you to execute "reverse" form or line feeds from the control panel. To move paper backwards, manually rotate the platen knob.

To advance paper by a page or a line:

1. If the printer is offline, check that the MODE indicators are off. If any of the indicators is on, repeatedly press the MODE button until the indicators are off.
2. Press FF to advance the paper by one page. Press LF to advance the paper by one line.

NOTE

If PAPER OUT is lit, pressing FF will load paper to the top-of-form position. Pressing FF again will advance the paper by a page.

SWITCHING PAPER TYPES

If you have more than one type of job, it's often convenient to switch between using continuous forms and single sheets. This section explains how to switch back and forth between paper types. It's not necessary to remove the continuous forms paper from the printer.

Switching to Single Sheets

To switch from continuous forms to single sheets:

1. Tear off your printed pages.
2. Retract the forms paper to the park position (simultaneously press MODE and LF).

CAUTION

Failure to retract the forms paper will cause paper jams.

3. Move the paper select lever to the rear (single sheet) position.
4. Load the cut sheet stand or feeder. See **Loading Single Sheets** earlier in this chapter for details. If using the cut sheet stand, be sure to simultaneously press the MODE and LF buttons to advance the paper to top-of-form.

Now you're ready to print using single sheets.

Switching to Continuous Forms

To switch from single sheets to continuous forms:

1. If a sheet of paper is loaded, turn the platen knob or execute a forward form feed to remove it.

CAUTION

Failure to remove the paper will cause paper jams.

2. Move the paper select lever to the forward (continuous forms) position.
3. Simultaneously press the MODE and LF buttons. The continuous forms paper will advance to top-of-form.

You're ready to print using continuous forms paper.

TIPS ON HANDLING PAPER

General Tips

- Use high quality paper. Do not use paper that is wrinkled or curled at the edges.
- Do not use paper with staples or metal parts.
- Store paper in a clean, dry environment.
- Check paper placement and alignment each time you use the printer. For long print jobs using continuous forms, check the paper stacks periodically. Be sure the outgoing stack is folding properly.

Multi-part Forms

- Do not print using more than four parts (original plus three copies). For carbon-interleaved forms, be sure to count the carbon as a copy.
- Avoid using carbon-interleaved single sheets. Printing tends to become misaligned on the bottom sheet.
- To ensure smoother feeding of paper-stapled multi-part forms, raise the cut sheet stand as a support behind the forms.

Envelopes

To print on envelopes, use the cut sheet stand or a cut sheet feeder equipped with an envelope adapter. Keep the following in mind:

- Use envelopes with a maximum thickness of .5 mm (.02 inch) at the multi-layer part.
- Set the paper thickness lever to the *down* (bottom) position.
- When loading envelopes, be sure the flaps of the envelopes face forward. Otherwise, jamming may occur.
- Be sure the print area specified by your application software is within the printable area of the envelope. Printing past the edge of the envelope will damage the print head and platen. To check that printing occurs in the correct area, print a sample using standard size paper.

Labels

- Be careful to use labels under normal operating conditions. Labels are sensitive to temperature and humidity.
- Only use labels mounted on continuous forms backing sheets. Do not print labels mounted on single sheet backing. Labels mounted on single sheet backing tend to slip and print crooked.
- Set the paper thickness lever to the *down* (bottom) position.
- Do not feed labels backwards using unload (MODE + LF) from the control panel. Jamming may occur.
- Do not use the printer's tear-off feature. When the labels are retracted, they may peel off the backing and become jammed in the printer.
- Do not leave labels loaded in the printer where they can become curled around the platen. Jamming may occur when you resume printing.
- Test labels before using them. If jamming occurs, be sure the paper thickness lever is set to the *down* position. If jamming problems continue, try a different type of label.

PRINTING

This chapter describes everyday print operations. To load paper for printing, see Chapter 3. Then use the procedures in this chapter to:

- Select print features
- Start, stop, or resume printing
- Remove printed pages
- Clear the print buffer

SELECTING PRINT FEATURES

The print features you select determine how your printed pages will look. Print features include the following:

- Print quality
- Fonts
- Pitch (characters per horizontal inch)
- Page length and width
- Line spacing (lines per vertical inch)
- Color

To select print features, you can use either commercial software or the printer's control panel. Which method you use depends upon the capabilities of your software. If your software has most of the features you require, you may rarely — if ever — use the control panel to select print features. *In fact, your software will often override the printer's settings.*

If your software has limited options, you can use the printer's control panel to select print features. Sometimes the control panel allows you to select features your software lacks. For example, you can select font cards or downloaded fonts not supported by your software.

Using Commercial Software

Many of today's commercial software packages offer a wide variety of print features, including features not offered by the printer. For example, software often provides a wider range of font sizes than the printer. It also allows you to specify multiple fonts on a page and multi-color printing. To determine which features your software supports and how to select them, refer to your software documentation.

Using the Control Panel

Using the MODE, FF, and LF buttons, you can select from the following sets of options listed on the printer's control panel (see below):

- MENU 1 or MENU 2
- LETTER or DRAFT
- FONT 1 or FONT 2

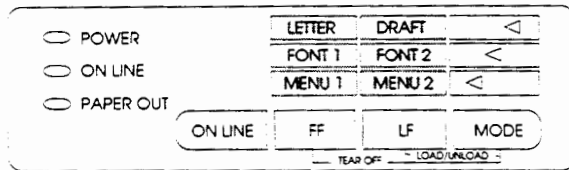

Printer control panel

MENU 1 and MENU 2 represent two different sets of print features such as the emulation, print quality, font, pitch, line spacing, and so on. FONT 1 and FONT 2 represent two different font/pitch combinations. To assign print features to MENU 1 and MENU 2, or to assign a font and pitch to FONT 1 and FONT 2, the printer's setup mode is used. For monochrome printers, you can also assign regular draft or high-speed draft print quality to DRAFT on the control panel.

If you haven't already assigned values to MENU 1, MENU 2, FONT 1, FONT 2, and DRAFT, go to Chapter 5 now to enter setup mode and do so.

When you first turn the printer on, MENU 1 is active. All of the print features assigned to MENU 1 are active. But you can easily switch to MENU 2 before printing. In addition, you can select different print qualities (LETTER or DRAFT) and font/pitch settings (FONT 1 or FONT 2) than those already assigned to MENU 1 and MENU 2.

NOTE

For easy reference, it's a good idea to keep a list of your current MENU 1, MENU 2, FONT 1, and FONT 2 settings near the printer. To print a list of current settings, see *Printing a List of Selected Options* in Chapter 5. You may also wish to use the space provided in Table 4.1 to record your settings.

Selecting MENU 1 or MENU 2

When you first turn the printer on, MENU 1 is active. To switch to MENU 2, or to switch back to MENU 1 again, follow these steps.

1. Press ONLINE to place the printer offline.
2. Repeatedly press MODE until the bottom MODE indicator is lit:

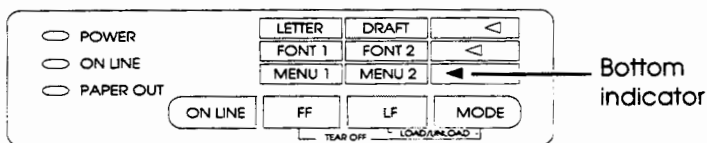

3. To select MENU 1, press FF. To select MENU 2, press LF.
4. To change the print quality or font/pitch setting, see the next two sections. Otherwise, press ONLINE to return online. You are now ready to print using the selected menu.

Table 4.1 MENU 1, MENU 2, FONT 1, and FONT 2 Settings

Possible Settings	Default Settings			
	For easy reference, check (✓) or mark your default settings in the space below.			
Print Feature	MENU 1	MENU 2	FONT 1	FONT 2
Emulation Fujitsu DPL24C PLUS IBM Proprinter XL24 Epson LQ-2500 Epson LQ-2550 Emulation card			—	—
Print quality Letter Report Draft High-speed draft (monochrome printers only)			—	—
Font Courier 10 Prestige Elite 12 Compressed font Boldface Pica 10 Correspondence font Font name in font card Download font 0 Download font 1				
Pitch 2.5, 3, 5, 6, 10, 12 15, 17, 18 or 20 cpi Proportional spacing				
Other features:			—	—

Changing the print quality

Before printing, you can use the control panel to select either LETTER or DRAFT print quality. You won't need to do this if you just selected a menu (MENU 1 or MENU 2) with the appropriate print quality. To change the print quality:

1. Be sure the printer is offline. Be sure the menu you want — either MENU 1 or MENU 2 — is selected. See the previous section.
2. Repeatedly press MODE until the top MODE indicator is lit:

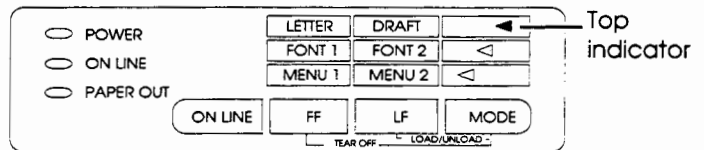

3. To select LETTER, press FF. To select DRAFT, press LF.
4. To change the font/pitch setting, see the next section. Otherwise, press ONLINE to return online for printing. You are now ready to print using the selected menu and print quality.

NOTE

The new print quality remains active until you change it, turn the printer off, or select MENU 1 or MENU 2 again.

Printing

Changing the font/pitch

Before printing, you can use the control panel to select the font/pitch you assigned to either FONT 1 or FONT 2 in setup mode. You won't need to do this if you just selected a menu (either MENU 1 or MENU 2) with the appropriate font/pitch. To change the font/pitch:

1. Be sure the printer is offline. Be sure the menu you want — either MENU 1 or MENU 2 — is selected.
2. Repeatedly press MODE until the middle MODE indicator is lit:

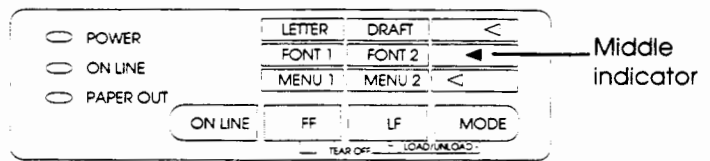

3. To select FONT 1, press FF. To select FONT 2, press LF.
4. To change the print quality, see the previous section. Otherwise, press ONLINE to return online for printing. You are now ready to print using the selected menu and font/pitch setting.

NOTE

The new font/pitch setting remains active until you change it, turn the printer off, or select MENU 1 or MENU 2 again.

PRINTING

Start Printing

Before you start to print, be sure that paper is loaded. Also verify that the paper thickness lever is set to the appropriate position (up, middle, or down).

To start printing, use the commands provided by your software or computer.

Stop Printing

To stop printing immediately, press the ONLINE button to place the printer offline. You can also use your software to stop printing, but there will be a slight delay before printing stops. Any data sent to the print buffer but not yet printed is stored until you resume printing or is lost when you turn the printer off.

To resume printing, press ONLINE again. To cancel printing, use the cancel commands provided by your software or computer to stop sending data to the printer. To clear the print buffer, turn the printer off. Any data sent to the print buffer before you canceled will be lost.

Resuming from Paper-Out

The printer can “sense” when paper runs out. Depending upon how PPR-OUT (paper-out) is set in setup mode, it will either:

- Stop printing and turn on the red PAPER OUT indicator, or
- Continue printing until no more data remains

See Chapter 5 for details on setting PPR-OUT. The factory default is to stop printing when continuous forms paper runs out, and to continue printing when the cut sheet stand is empty.

CAUTION

When using the cut sheet stand, be careful not to run out of paper while printing. Printing on the platen will damage the printer.

If a cut sheet feeder runs out of paper, the printer always stops printing, regardless of the PPR-OUT setting.

To resume printing when paper runs out:

1. Install paper on the forms tractors or in the cut sheet feeder bin. See Chapter 3 for details.

2. To load the first sheet of paper, either press FF or simultaneously press MODE and LF. The PAPER OUT indicator will turn off.

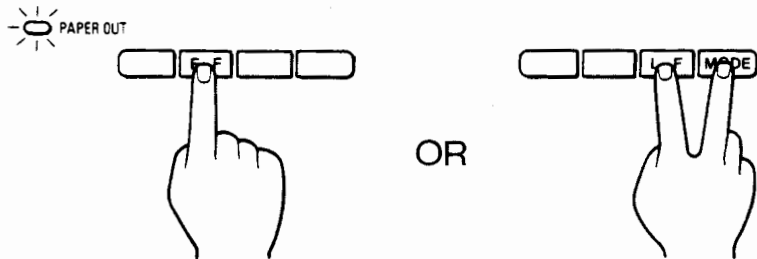

NOTE

Pressing FF loads paper only when PAPER OUT is lit.

3. Press the ONLINE button to place the printer online and resume printing.

NOTE

For continuous forms, the page where printing stopped and the page where printing resumes will probably be incorrectly printed. Wait for the entire job to finish printing. Then reprint these pages.

REMOVING PRINTED PAGES

This section describes the best methods for removing single sheets or continuous forms paper after printing.

Removing Single Sheets

When you print using software, the printer automatically ejects each sheet of paper when the end of the printed page is reached. To eject sheets manually, use one of the following methods:

- Execute a form feed (press FF with the MODE indicators off)
- Turn the platen knob clockwise

Removing Continuous Forms

To avoid wasting paper, use the printer's tear-off edge to remove continuous forms paper. Simultaneously press the MODE and FF buttons to advance the perforation to the tear-off edge (the MODE indicators must be off). Tear the paper off, then press any button to retract the paper back to the top-of-form position. See Chapter 3 for more detailed instructions.

CLEARING THE PRINT BUFFER

Turning the printer off clears all data from the print buffer. This is useful when you cancel a print operation and don't want to continue printing the data already sent to the printer. When you turn the printer on again, its power-on defaults will be active.

USING SETUP MODE

Your printer has two modes, normal mode and setup mode. *Normal mode* — used for everyday printer operations — is explained in Chapters 3 and 4. This chapter explains how to use *setup mode*.

Setup mode serves two purposes. It allows you to:

- Select the printer's optional settings
- Help diagnose printer problems

Optional settings on the printer include the emulation, fonts, pitch, page length and width, serial interface options, and top-of-form setting. When you save your settings in the printer's permanent memory, they become the new default settings, called "defaults" for short. The defaults are active whenever you turn on the printer. For example, if you save DPL24C PLUS as the default emulation, DPL24C PLUS is active when you turn on the printer.

The printer's diagnostic functions are SELF-TST, HEX-DUMP, and V-ALMNT. These functions are helpful for printer troubleshooting, as described in Chapter 7. HEX-DUMP is also used by programmers to print hex dumps.

HOW TO USE THIS CHAPTER

The sections in this chapter are presented in a logical sequence. *If you are a first-time user, read the following sections first:*

- Entering Setup Mode
- Overview of Setup Mode

These sections will familiarize you with how setup mode works. Once you understand the basics, use the following sections to select printer options which are compatible with your hardware and software setup:

- Printing a List of Selected Options
- Deciding Which Options to Change
- Changing Panel Options
- Changing MENU 1 and MENU 2 Options
- Changing Hardware Options
- Changing Top-of-Form
- Exiting and Saving

To restore the printer's default settings (factory defaults or power-on defaults), see **Resetting Defaults**.

For information on using the SELF-TST, HEX-DUMP, and V-ALMNT functions, see **Using the Diagnostic Functions**.

For Experienced Users:

After you are familiar with setup mode, you may wish to use the flowchart at the end of this chapter for quick reference. This flowchart lists all of the printer's setup functions, items, and options.

ENTERING SETUP MODE

Before entering setup mode, load continuous forms paper into the printer (see Chapter 3 for paper loading instructions). Several sheets of paper may be required to make all of your setup selections.

To enter setup mode, follow these steps.

1. Make sure continuous forms paper is loaded and the paper select lever is set to the forward position.
2. Turn the printer off.

NOTE

To enter setup mode, you must first turn the printer off.

3. While pressing the MODE button, turn the printer back on. Continue pressing MODE until the printer beeps.

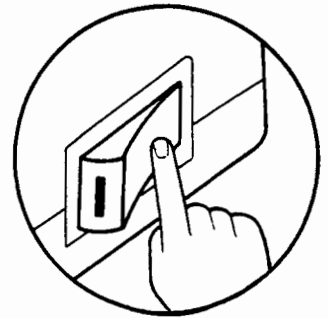
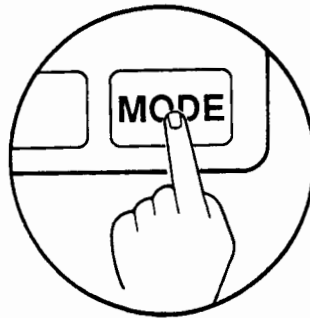

Entering setup mode

If you don't hear a beep and the printer goes online, you are not in setup mode. Turn off the power and try again. Make sure you press MODE until the printer beeps.

4. The printer enters offline setup mode and prints the following information.

***** OFFLINE SETUP MODE *****

- The red cursor indicates the option to be selected.
 - The selected option is underlined.
 - "SAVE&END" function must be selected to exit setup mode.
 - Following list shows how buttons function in setup mode:

BUTTON	ACTION on <<FUNCTION>> menu	ACTION on <ITEM> menu
ONLINE	Reprint <<FUNCTION>> menu	Select option & return to <<FUNCTION>> menu
F F	Select function	Select option & print next item
L F	Select function	Select option & print previous item
MODE	Move cursor to next function	Move cursor to next option

<<FUNCTION>> menu
 FUNCTIONS: SAVE&END PANEL MENU1 MENU2 HARDWARE LIST DEFAULT SELF-TST REZ-DUMP V-ALHWT
 TOP-ALW

Red cursor on print guide

Initial printout in setup mode

The initial printout contains a header, a "Help" menu, and the <<FUNCTION>> menu. The header tells you that the printer is offline and in setup mode. The Help menu provides a quick summary of how to use setup mode. Finally, the <<FUNCTION>> menu lists all of the functions available to you in setup mode. Note that the red cursor on the plastic print guide is initially positioned below the SAVE&END function.

OVERVIEW OF SETUP MODE

When you enter setup mode, as described in the previous section, the <<FUNCTION>> menu is always printed:

```

<< FUNCTION >>
SAVE&END PANEL  MENU1  MENU2  HARDWRE          LIST  DEFAULT  SELF-TST  HEX-DUMP  V-ALMNT
TOP-ADJ
    
```

The purpose of each function is briefly described in the table below.

Table 5.1 Setup Functions

Function	Purpose
SAVE&END	Exit setup mode and save any changes made while in setup mode.
PANEL	Assign a font and pitch to FONT 1 and FONT 2 on the printer's control panel. For monochrome printers, you may also assign regular or high-speed draft print quality to DRAFT on the control panel.
MENU1 and MENU2	Assign print features to MENU 1 and MENU 2 on the printer's control panel.
HARDWRE	Change the printer's hardware options.
LIST	Print a list of all currently selected options.

Table 5.1 Setup Functions (Cont.)

Function	Purpose
DEFAULT	Reset factory defaults in MENU 1 and MENU 2.
SELF-TST	Run the self-test.
HEX-DUMP	Print hex dumps.
V-ALMNT	Check and correct vertical print alignment.
TOF-ADJ	Set top-of-form.

To select a function from the <<FUNCTION>> menu:

1. Repeatedly press MODE to position the red cursor on the plastic print guide beneath the function you require.
2. Press FF to underline (select) the function. If the function has items and options, the printer will print the first item and its options. The PANEL, MENU1, MENU2, HARDWRE, and TOF-ADJ functions contain items that have selectable options. The other functions do not have items or options.

As an example, the first three MENU1 items and their options are shown below. Items are enclosed in brackets < >.

< EMULATE >	<u>D</u> PL24C+ IBMXL24	LQ2500	LQ2550
< FONT >	<u>C</u> OUR 10 PRSTG12 COMPRSD BOLDPCE PICA 10	CORRESP	DOWNLDO DOWNLD1
< QUALITY >	<u>L</u> ETTER REPORT	DRAFT	HI-DRFT

For each item, the option with a short underline beneath it is the current default option (the option currently saved in the printer's permanent memory). In the previous example, the default options are: Fujitsu DPL24C PLUS emulation, Courier 10 font, letter print quality.

The chart on the opposite page summarizes how to use the printer's buttons to select options such as the emulation, font, and print quality. It also summarizes how to use the buttons with functions which have no items and selectable options.

Setup Mode Example

To help become familiar with setup mode, try the following example, which takes only a few minutes to complete. This example shows how to change the font and pitch in MENU 2 to Prestige Elite 12 and 12 cpi.

1. Load continuous forms paper.

2. Enter setup mode.

While pressing MODE, turn the printer on. Continue pressing MODE until the printer beeps.

3. Select the MENU2 function.

Wait for the printer to stop printing and press MODE three times to position the red cursor on the print guide beneath MENU2. Press FF to underline (select) the MENU2 function and print the <EMULATE> item and its options.

4. Select the current emulation.

Since you do not want to change the emulation, press FF to underline (select) the current emulation and print the item and its options.

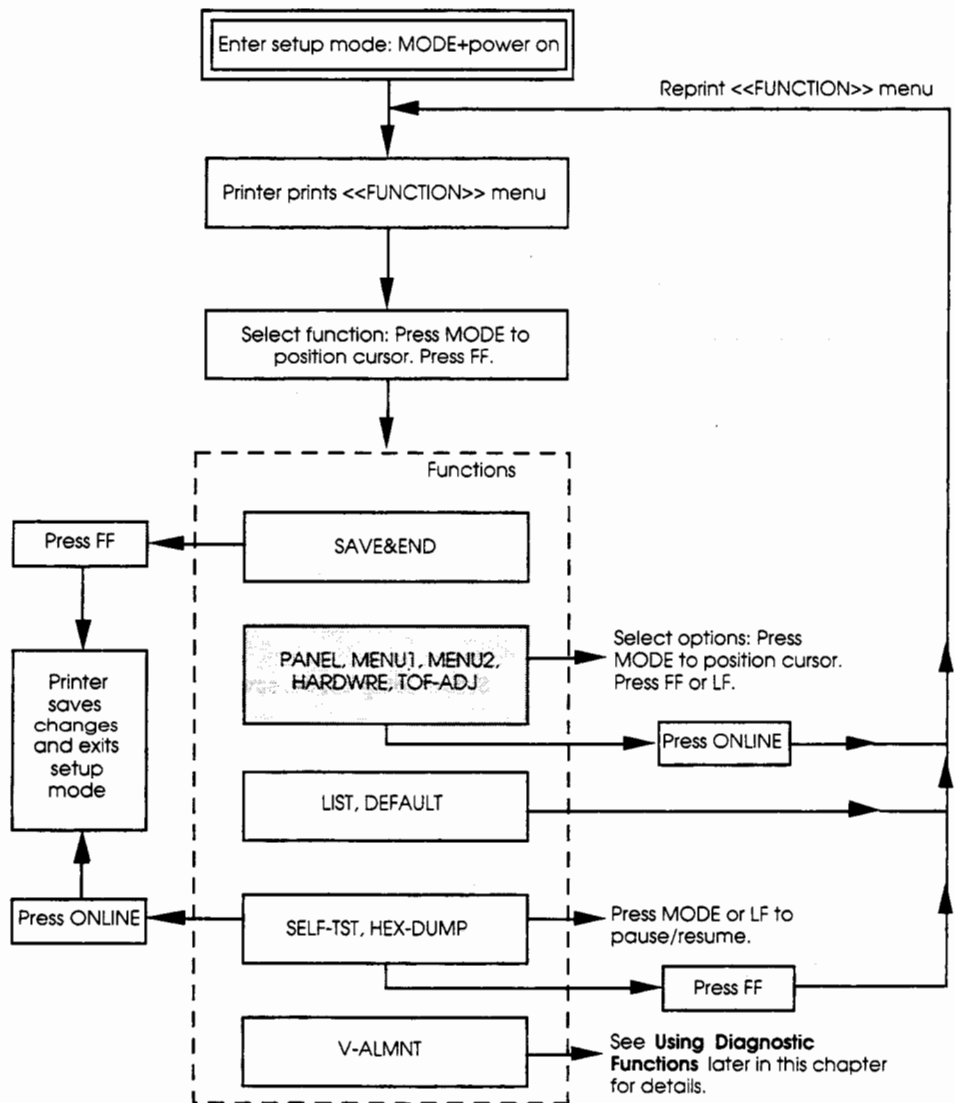

: Functions with items and options.

Summary of Setup Mode

5. Change the font to Prestige Elite 12.

Press MODE once to position the cursor beneath PRSTG12. Press FF to underline (select) PRSTG12 and print the next item, <QUALITY>, and its options.

6. Select the current print quality.

Since you do not want to change the print quality, press FF to underline (select) the current print quality and print the next item, <PITCH>.

7. Change the pitch to 12 cpi and exit the MENU2 function.

Press MODE once to position the cursor beneath 12 CPI. Since you do not want to make any other changes in MENU2, press ONLINE to underline (select) 12 CPI and exit MENU2. The <<FUNCTION>> menu is reprinted.

8. Exit setup mode, saving the new font and pitch.

Check that the cursor is beneath SAVE&END. Press FF to underline (select) SAVE&END. The printer will save Prestige Elite 12 and 12 cpi as the new power-on defaults in MENU 2, exit setup mode, and return online. These settings will remain in effect until you change them.

Points to Remember

- Load continuous forms paper *before entering setup mode*. In setup mode, the FF, LF, and MODE buttons cannot be used to load or feed paper. To load paper in setup mode, you'll have to use the platen knob.
- Whenever you enter setup mode, short "Help" menus are printed at the top of the page. Help menus are also printed when you select the SELF-TST, HEX-DUMP, or V-ALMNT functions. Use the Help menus for quick reference while using setup mode.
- When printing the items and options for each function, you can only print one item at a time. However, you can move either forward or backwards in the item list. To move forward (print the next item), press FF. To move backwards (print the previous item), press LF.
- A short underline beneath the first two letters of an option indicates that it is the current default setting. For example, 12 CPI indicates that 12 characters per inch is the default pitch. To change the default, you must select and save a new pitch setting.
- While in setup mode, you can always use the LIST function to print out a list of your currently selected options (see the next section for details).
- To exit setup mode and permanently save your changes, you must select either the SAVE&END function or the SELF-TST function. For details, see **Exiting and Saving** later in this chapter. To exit setup mode without saving your changes, turn the printer off. Your previous power-on defaults will be active when you turn the printer on again.

PRINTING A LIST OF SELECTED OPTIONS

The LIST function allows you to print a list of all the printer's currently selected options. This is handy for checking the printer's settings when you first enter setup mode or just before you exit. To print a list of options, load continuous forms paper. Then follow these steps.

1. Enter setup mode.

While pressing MODE, turn the printer on. Wait for the printer to stop printing and check that the <<FUNCTION>> menu is printed:

```

<<FUNCTION>>
SAVE&END PANEL  MENU1  MENU2  HARDWRE          LIST  DEFAULT  SELF-TST  HEX-DUMP  V-ALMNT
TOP-ADJ
    
```

2. Select the LIST function.

Repeatedly press MODE to position the red cursor beneath LIST. Press FF. The printer underlines (selects) LIST and starts to print a list of all currently selected options. The preselected factory settings, also called factory defaults, are shown on the opposite page.

When the printer finishes printing the list of options, it reprints the <<FUNCTION>> menu.

NOTE

To remove the printout, turn the platen knob until the paper can be torn off at the perforation. In setup mode, you cannot use the printer's tear-off feature (MODE + FF buttons).

3. Do one of the following:

- Select another function.
- Exit setup mode, saving any changes you made.

For details about other functions, see the other sections in this chapter. To exit setup mode and save your changes, make sure the red cursor is positioned beneath SAVE&END. Press FF.

*** Setup parameters ***

<< Menu 1 settings >>

Func.	Item	Option
MENU 1	EMULATE	DPL24C+
MENU 1	FONT	COUR 10
MENU 1	QUALITY	LETTER
MENU 1	PITCH	10 CPI
MENU 1	LINE SP	6 LPI
MENU 1	CHAR-W	NORMAL
MENU 1	CHAR-H	NORMAL
MENU 1	ATTRIB	NONE
MENU 1	PAGE LG	11.0 IN
MENU 1	COLOR	AUTOSEL (*1)
MENU 1	LFT-END	1 COLM
MENU 1	TOP-MRG	1 LINE
MENU 1	LANGUGE	PAGE437
MENU 1	CHR-SET	SET 2
MENU 1	PRF-SKP	NO-SKIP
MENU 1	WIDTH	11.0 IN
MENU 1	ZEROFNT	NO-SLSH
MENU 1	DC3-CDE	ENABLE
MENU 1	CR-CODE	CR ONLY
MENU 1	LF-CODE	LF & CR
MENU 1	RGHTEND	WRAP
MENU 1	==END==	

<< Menu 2 settings >>

Func.	Item	Option
MENU 2	EMULATE	DPL24C+
MENU 2	FONT	COUR 10
MENU 2	QUALITY	LETTER
MENU 2	PITCH	10 CPI
MENU 2	LINE SP	6 LPI
MENU 2	CHAR-W	NORMAL
MENU 2	CHAR-H	NORMAL
MENU 2	ATTRIB	NONE
MENU 2	PAGE LG	11.0 IN
MENU 2	COLOR	AUTOSEL (*1)
MENU 2	LFT-END	1 COLM
MENU 2	TOP-MRG	1 LINE
MENU 2	LANGUGE	PAGE437
MENU 2	CHR-SET	SET 2
MENU 2	PRF-SKP	NO-SKIP
MENU 2	WIDTH	11.0 IN
MENU 2	ZEROFNT	NO-SLSH
MENU 2	DC3-CDE	ENABLE
MENU 2	CR-CODE	CR ONLY
MENU 2	LF-CODE	LF & CR
MENU 2	RGHTEND	WRAP
MENU 2	==END==	

<< Panel settings >>

Func.	Item	Option
PANEL	FONT1	COUR 10
PANEL	F1PITCH	10 CPI
PANEL	FONT2	PRSTG12
PANEL	F2PITCH	12 CPI
PANEL	==END==	

<< Hardware settings >>

Func.	Item	Option
HARDWRE	PPR-OUT	CNTONLY
HARDWRE	PRT-DIR	BI-DIR
HARDWRE	BUZZER	ON
HARDWRE	WORD-LG	8 BIT
HARDWRE	BUFFER	8KBYTE
HARDWRE	FEEDER	REAR
HARDWRE	FORMAT	8NONE 1
HARDWRE	BAUD-RT	9600
HARDWRE	PROTOCL	XON/XOF
HARDWRE	DSR	IGNORE
HARDWRE	DUPLEX	FULL
HARDWRE	==END==	

<< Top of form settings >>

Func.	Item	Option
TOF-ADJ	ORIGIN	1 INCH
TOF-ADJ	FINEADJ	0
TOF-ADJ	==END==	

*1 Listed for color models

*2 Listed for models with a serial interface

Printout of factory defaults using LIST

DECIDING WHICH OPTIONS TO CHANGE

On the previous page, a printout of the printer's factory default settings is shown. In this printout, options are listed by functional group:

- Panel settings (PANEL function)
- Menu 1 settings (MENU1 function)
- Menu 2 settings (MENU2 function)
- Hardware settings (HARDWRE function)
- Top of form settings (TOF-ADJ function)

Most selectable options will only alter print features such as the typestyle, page format, and selection of color. However, some options must be selected correctly for the printer to work properly with your hardware and software. For each function, Table 5.2 lists those items whose options must be selected correctly for system and printer accessory compatibility.

Table 5.2 Required Options

Function	Item	Required Options
PANEL	None	None. See Changing Panel Options later in this chapter.
MENU1	EMULATE	<p>The emulation selected on the printer must be the same as the emulation selected in your software. If you selected an emulation when you set up the printer (Chapter 2), you will not need to change the EMULATE option unless you want to switch to a different emulation. The emulation assigned to MENU 1 is the default when you turn the printer on.</p> <p>See Changing MENU 1 and MENU 2 Options later in this chapter.</p>

Table 5.2 Required Options (Cont.)

Function	Item	Required Options
MENU2	None	Options in the MENU2 function must be changed only if you plan to select MENU 2 from the printer's control panel. If so, <i>the emulation selected for MENU 2 must be the same as the emulation selected in your software.</i> See Changing MENU 1 and MENU 2 Options later in this chapter.
HARDWRE	FEEDER FORMAT BAUD-RT PROTOCL DSR DUPLEX	Change the FEEDER option if you install a cut sheet feeder. If single or double bin is not correctly specified, the feeder will not work. <i>If you have a serial interface, the serial interface options selected on the printer must be the same as the settings selected using your software or your computer's operating system. Otherwise, the printer won't print, or it won't print the correct characters.</i> See Changing Hardware Options later in this chapter.
TOF-ADJ	None	If you are not using software to specify the top margin of the page, we recommend using the printer's default top-of-form setting — 1 inch (25.4 mm) from the top of the page. If you are using software to specify the top margin of the page, we recommend changing the default setting to 1/6 inch (4.2 mm). See Changing Top-of-Form later in this chapter.

CHANGING PANEL OPTIONS

The PANEL function allows you to change the font and pitch assigned to FONT 1 and FONT 2 on the printer's control panel. In normal (non-setup) mode, you can use the control panel to easily switch back and forth between the fonts for printing (see Chapter 4 for details). For monochrome printers, the PANEL function also allows you to assign regular draft or high-speed draft print quality to DRAFT on the printer's control panel.

The PANEL items and options are listed in Table 5.3. Items are listed in the order in which they are printed. All settings are optional; none are required. The procedure for changing the panel options follows Table 5.3.

Table 5.3 PANEL Items and Options

NOTE: Underlined options are the factory defaults.

PANEL Items	Options	Description
<DRAFT>	<u>DRAFT</u> HI-DRFT	Available only for monochrome printers. This item will not print if you have a color printer. Regular draft print quality. Prints three times as fast as letter print quality. High-speed draft print quality. Prints four times as fast as letter print quality.
<FONT1>	<u>COUR10</u> PRSTG12 COMPRSD BOLDFCE PICA 10 CORRESP XXXXXXX DOWNLD#	For each font below, recommended pitch settings are given in parentheses. When you change the font, be sure to also change the pitch, if required. Courier 10 (10 cpi) Prestige Elite 12 (12 cpi) Compressed font (15, 17, and 18 cpi) Boldface (proportional) Pica 10 (10 cpi) Correspondence (10 cpi) Font names in a font card Font 0 or font 1 in the printer's download RAM

Table 5.3 PANEL Items and Options (Cont.)

NOTE: Underlined options are the factory defaults.

PANEL Items	Options	Description
<F1PITCH>	## CPI PROP SP	2.5, 3, 5, 6, <u>10</u> , 12, 15, 17, 18 or 20 cpi (characters per horizontal inch) Proportional spacing
<FONT2>	Same options as <FONT1>; <u>PRSTG12</u>	The factory default for FONT2 is Prestige Elite 12.
<F2PITCH>	Same options as <F1PITCH>; <u>12 CPI</u>	The factory default for F2PITCH is 12 cpi.
<==END==>	---	Indicates the end of the PANEL items. Press FF to print the first item. Press LF to print the previous item, <F2PITCH>. Press ONLINE to reprint the <<FUNCTION>> menu.

Setup Mode

√ **Procedure**

To change the panel options, make sure continuous forms paper is loaded. Then take the following steps.

1. Enter setup mode.

While pressing MODE, turn the printer on. Wait for the printer to stop printing and check that the <<FUNCTION>> menu is printed:

```

<< FUNCTION >>
SAVE&END PANEL  MENU1  MENU2  HARDWRE          LIST  DEFAULT  SELF-TST  HEX-DUMP  V-ALMNT
TOP-ADJ
    
```

2. Select the PANEL function.

Repeatedly press MODE to position the red cursor beneath PANEL. Press FF to underline (select) PANEL and print the first item and its options. If you have a monochrome printer, the <DRAFT> options are printed. Go to step 3.

```
< DRAFT >      DRAFT  HI-DRPT
```

If you have a color printer, the <FONT1> options are printed. Skip to step 4.

```
< FONT1 >
COUR 10  PRSTG12  COMPRSD  BOLDPCE  PICA 10          CORRESP  DOWNLDO  DOWNLDI
```

3. Assign a print quality to DRAFT (monochrome printers only).

Repeatedly press MODE to position the cursor beneath the print quality you want. Press FF to underline (select) the quality and print the <FONT1> options.

4. Assign a font to FONT 1.

Repeatedly press MODE to position the cursor beneath the font you want. Press FF to underline (select) the font and print the <F1PITCH> options:

```
< F1PITCH >
2.5CPI  3 CPI  5 CPI  6 CPI  10 CPI          12 CPI  15 CPI  17 CPI  18 CPI  20 CPI
PROP SP
```

5. Assign a pitch to FONT 1.

Repeatedly press **MODE** to position the cursor beneath the pitch you want. Press **FF** to underline (select) the pitch and print the <FONT2> options.

6. Assign a font and pitch to FONT 2.

Use the same method as in steps 4 and 5.

7. Exit PANEL.

Press **ONLINE** to exit the **PANEL** function and reprint the <<FUNCTION>> menu.

8. Do one of the following:

- **Select another function.**
- **Exit setup mode, saving your changes.**

For details about other functions, see the other sections in this chapter. To exit setup mode and save your changes, make sure the red cursor is positioned beneath **SAVE&END**. Press **FF**.

**CHANGING MENU 1
AND MENU 2 OPTIONS**

The **MENU1** and **MENU2** functions allow you to change the print options assigned to **MENU 1** and **MENU 2** on the printer's control panel. In normal (non-setup) mode, you can easily switch back and forth between the menus for printing. See Chapter 4 for details.

The **MENU1** and **MENU2** items and options are listed in Table 5.4. Both functions offer the same items and options. The items in Table 5.4 are listed in the order in which they are printed.

You must select the same emulation on the printer as in your software. Otherwise, the printer won't work correctly with your software. If you plan to use two different emulations on a regular basis, assign the most frequently used emulation to **MENU 1**. Assign the other emulation to

MENU 2. All of the other settings available for MENU 1 and MENU 2 are optional. For emulation cards, some of the items and options will differ from those shown in Table 5.4.

To determine which features your software supports, refer to your software documentation. If you have a color printer, note that the default for <COLOR> is AUTOSEL, which allows you to specify color using your software.

The procedure for changing the MENU1 and MENU2 options follows Table 5.4.

Table 5.4 MENU1 and MENU2 Items and Options

NOTES:

- Underlined options are the factory defaults.
- Footnotes denote items and options which differ for the IBM XL24 and Epson LQ-2500/-2550 emulations. See the end of this table for meanings of footnotes.

MENU1 and MENU2 Items	Options	Description
<p><EMULATE></p>		<p>Select the same emulation as the one selected in your software. See Selecting an Emulation in Chapter 2 for pointers on selecting an emulation.</p>
	<p><u>DPL24C+</u></p>	<p>Fujitsu DL-series printers (DPL24C PLUS command set)</p>
	<p>IBMXL24</p>	<p>IBM Proprinter XL24 printers</p>
	<p>LQ2500</p>	<p>Epson LQ-2500 printers</p>
	<p>LQ2550</p>	<p>Epson LQ-2550 printers</p>
<p>XXXXXXXX</p>	<p>Name of printer emulation available on the currently installed emulation card</p> <p>NOTE: When you select a new emulation, all MENU1 or MENU2 options are reset to the factory defaults for that emulation.</p>	

Table 5.4 MENU1 and MENU2 Items and Options (Cont.)

NOTES:

- Underlined options are the factory defaults.
- Footnotes denote items and options which differ for the IBM XL24 and Epson LQ-2500/-2550 emulations. See the end of this table for meanings of footnotes.

MENU1 and MENU2 Items	Options	Description
<p></p>	<p><u>COUR 10</u> PRSTG12 COMPRSD BOLDFCE PICA 10 CORRESP</p> <p>XXXXXXXX DOWNLD#</p>	<p>For each font below, recommended pitch settings are given in parentheses. When you change the font, be sure to also change the pitch, if required.</p> <p>[Illus. 5-1^A] [Ilus. 5-1^B] [Ilus. 5-1^C] [Ilus. 5-1^D] [Ilus. 5-1^E] [Ilus. 5-1^F]</p> <p>Font names in a font card Font 0 or font 1 in the printer's download RAM</p> <p>See Appendix A in the programmer's manual for font examples.</p>
	<p><QUALITY></p>	<p><u>LETTER</u></p>
<p>REPORT</p>		<p>Report print quality. Provides lower resolution than letter quality at twice the speed.</p>

Setup Mode

Table 5.4 MENU1 and MENU2 Items and Options (Cont.)

NOTES:

- Underlined options are the factory defaults.
- Footnotes denote items and options which differ for the IBM XL24 and Epson LQ-2500/-2550 emulations. See the end of this table for meanings of footnotes.

MENU1 and MENU2 Items	Options	Description
	DRAFT	Regular draft print quality. Provides lower resolution than report quality at three times letter speed.
	HI-DRFT	High-speed draft print quality. Provides lower resolution than draft quality at four times letter speed. <i>Available only for monochrome printers.</i> This option will not print if you have a color printer.
<PITCH>	## CPI	2.5, 3, 5, 6, <u>10</u> , 12, 15, 17, 18 or 20 cpi (characters per horizontal inch)
	PROP SP	Proportional spacing
<LINE SP>	## LPI	1, 2, 3, 4, 5, <u>6</u> , 7, or 8 lpi (lines per vertical inch)
		6 lpi 3 lpi (double spacing)
		ABCD ABCD
		ABCD
		ABCD ABCD
		ABCD
		ABCD ABCD

Table 5.4 MENU1 and MENU2 Items and Options (Cont.)

NOTES:

- Underlined options are the factory defaults.
- Footnotes denote items and options which differ for the IBM XL24 and Epson LQ-2500/-2550 emulations. See the end of this table for meanings of footnotes.

MENU1 and MENU2 Items	Options	Description
<CHAR-W>		If necessary, change the pitch when 2 TIMES or 4 TIMES is selected.
	<u>NORMAL</u>	Standard character width ABCD
	2 TIMES	Double character width ABCD
	4 TIMES (*1)	Quadruple character width ABCD
<CHAR-H>		If necessary, change the line spacing when 2 TIMES or 4 TIMES is selected.
	<u>NORMAL</u>	Standard character height ABCD
	2 TIMES	Double character height ABCD
	4 TIMES (*1)	Quadruple character height ABCD

Setup Mode

Table 5.4 MENU1 and MENU2 Items and Options (Cont.)

NOTES:

- Underlined options are the factory defaults.
- Footnotes denote items and options which differ for the IBM XL24 and Epson LQ-2500/-2550 emulations. See the end of this table for meanings of footnotes.

MENU1 and MENU2 Items	Options	Description
<ATTRIB>		Select an attribute to add emphasis to your documents. Only one attribute may be selected at a time.
	<u>NONE</u>	Standard characters (no attributes)
	ITALICS (*1)	<i>Italic printing</i>
	CONDNSD (*1)	Condensed printing
	SHADOW	Double printing with a slight horizontal offset
	BOLD	Double printing at the same position
<PAGE LG>		Specifies the length of the page in inches.
	## IN	<p>For DPL24C PLUS and IBM XL24 emulations: 3.0, 3.5, 4.0, 5.0, 5.5, 6.0, 7.0, 8.0, 8.5, <u>11.0</u> (letter size), 11.6 (A4 size), 12.0, 14.0, or 18.0 inches</p> <p>For Epson LQ-2500/-2550 emulation: 4.0, 4.5, 5.0, ..., <u>11.0</u>, 11.5, ..., 22.0 inches</p>

Table 5.4 MENU1 and MENU2 Items and Options (Cont.)

NOTES:

- Underlined options are the factory defaults.
- Footnotes denote items and options which differ for the IBM XL24 and Epson LQ-2500/-2550 emulations. See the end of this table for meanings of footnotes.

MENU1 and MENU2 Items	Options	Description
<COLOR>	<p><u>AUTOSEL</u></p> <p>BLACK YELLOW MAGENTA CYAN</p>	<p><i>Available only for color printers. This item will not print if you have a monochrome printer.</i></p> <p>Select AUTOSEL (automatic color selection) to specify color using your software. Seven colors can be specified: black, yellow, red, blue, violet, orange, and green.</p> <p>Black Yellow Red Blue</p>
<LFT-END>	<p>## COLM</p>	<p>Specifies the starting column for the left end of the page. When the pitch is 12 cpi, 12 columns equals one inch. The left margin equals the number of columns specified by LFT-END, plus your software's left margin, if specified.</p> <p>Column <u>1</u>, 2, 3, ..., 41</p> <p>[Illus. 5-18]</p>

Setup Mode

Table 5.4 MENU1 and MENU2 Items and Options (Cont.)

NOTES:

- Underlined options are the factory defaults.
- Footnotes denote items and options which differ for the IBM XL24 and Epson LQ-2500/-2550 emulations. See the end of this table for meanings of footnotes.

MENU1 and MENU2 Items	Options	Description
<TOP-MRG>		<p>Specifies the top margin of the page in lines. To set <TOP-MRG> to 1 inch when line spacing equals 6 lpi, select 7 lines.</p> <p><i>The total size of your top margin equals the sum of these three settings: top-of-form, <TOP-MRG> setting, and the software-specified top margin. If you are using software to specify a top margin, we recommend using the default (1 line) for <TOP-MRG>.</i></p>
	## LINE	<p><u>1</u>, 2, 3, 4, 5, 6, 7, 8, 9, or 10 lines</p> <p>[Illus. 5-19]</p>
<LANGUGE>		<p>Selects a language. Appendix B in the programmer's manual shows the characters in each language.</p>
	USA	<p>American English (This is the same as code page 437.)</p>
	UK	<p>British English</p>
	GERMAN	<p>German</p>
	FRENCH	<p>French</p>

Table 5.4 MENU1 and MENU2 Items and Options (Cont.)

NOTES:

- Underlined options are the factory defaults.
- Footnotes denote items and options which differ for the IBM XL24 and Epson LQ-2500/-2550 emulations. See the end of this table for meanings of footnotes.

MENU1 and MENU2 Items	Options	Description
	ITALIAN SPANISH SWEDISH FINNISH DANISH1 DANISH2 NORWEGN PAGE### ISO8859 ECMA94	Italian Spanish Swedish Finnish Danish I Danish II Norwegian <u>Code page 437</u> , 850, 860, 863, or 865 (Code page 437 is the same as American English.) ISO-8859-1 ECMA-94
	(*4) SPANSH1 SPANSH2 JAPAN LATIN A	Spanish I Spanish II Japanese Latin America
<CHR-SET>	SET 1 <u>SET 2</u>	IBM character set 1 IBM character set 2 If a font card or download (soft) font is used, the character set for that font overrides the <CHR-SET> setting.
	(*4) <u>ITALIC</u> GRAPHIC	Italic characters available Graphics characters (ruled lines) available

Setup Mode

Table 5.4 MENU1 and MENU2 Items and Options (Cont.)

NOTES:



- Underlined options are the factory defaults.
- Footnotes denote items and options which differ for the IBM XL24 and Epson LQ-2500/-2550 emulations. See the end of this table for meanings of footnotes.

MENU1 and MENU2 Items	Options	Description
<AGM> (*2)	<u>OFF</u> ON	Alternate Graphics Mode (AGM) set off. Alternate Graphics Mode (AGM) set on.
<PRF-SKP>	SKIP <u>NO-SKIP</u>	For continuous forms, specifies whether an inch is skipped over the perforation. If you are not using software to specify a bottom margin, select SKIP when using thicker multi-part forms. One inch is skipped over the perforation. The perforation is not skipped. Printing continues in the bottom margin of the page.
<WIDTH>	<u>11.0 IN</u> 8.0 IN	11-inch page width 8-inch page width
<ZEROFNT> (*3)	<u>NO-SLSH</u> SLASH	Specifies whether to print the number zero with a slash. This is useful for distinguishing the capital letter "O" from the number "0". Invalid for some soft fonts and font cards. 0 Ø

Table 5.4 MENU1 and MENU2 Items and Options (Cont.)

NOTES:

- Underlined options are the factory defaults.
- Footnotes denote items and options which differ for the IBM XL24 and Epson LQ-2500/-2550 emulations. See the end of this table for meanings of footnotes.

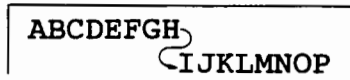
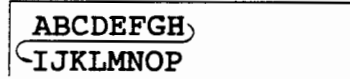
MENU1 and MENU2 Items	Options	Description
<DC3-CDE>	<u>ENABLE</u> DISABLE	The DC1 and DC3 codes are enabled. Any data received between DC3 and the next DC1 is ignored. DC1 and DC3 are ignored.
<CR-CODE>	<u>CR ONLY</u> CR & LF	No line feed is added to a carriage return.  A line feed is added to each carriage return. 
<LF-CODE> (*3)	LF ONLY <u>LF & CR</u>	No carriage return is added to a line feed.  A carriage return is added to each line feed. 

Setup Mode

Table 5.4 MENU1 and MENU2 Items and Options (Cont.)

NOTES:

- Underlined options are the factory defaults.
- Footnotes denote items and options which differ for the IBM XL24 and Epson LQ-2500/-2550 emulations. See the end of this table for meanings of footnotes.

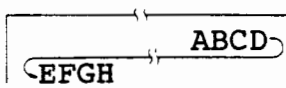
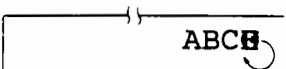
MENU1 and MENU2 Items	Options	Description
<RGHTEND>	<u>WRAP</u>	End-of-line wrap (carriage return plus line feed) 
	OVR-PRT	Characters are overprinted at the end of a line. 
<==END==>		Indicates the end of the MENU1 items. Press FF to print the first item, <EMULATE>. Press LF to print the previous item, <RGHTEND>. Press ONLINE to reprint the <<FUNCTION>> menu.

*1 Unavailable for the IBM XL24 emulation

*2 Available *only* for the IBM XL24 emulation

*3 Unavailable for the Epson LQ-2500/-2550 emulations

*4 Available *only* for the Epson LQ-2500/-2550 emulations

√ Procedure

To change the options assigned to MENU 1 or MENU 2, make sure continuous forms paper is loaded. Then take the following steps.

1. Enter setup mode.

While pressing MODE, turn the printer on. Wait for the printer to stop printing and check that the <<FUNCTION>> menu is printed:

```
<<FUNCTION>>
SAVE&END PANEL  MENU1  MENU2  HARDWRE      LIST  DEFAULT  SELF-TST  HEX-DUMP  V-ALMNT
TOP-ADJ
```

Setup Mode

2. Select the MENU1 or MENU2 function.

Repeatedly press MODE to position the red cursor beneath either the MENU1 or MENU2 function. Press FF to underline (select) the function and print the <EMULATE> options:

```
<EMULATE>      DPL24C+  IBMXL24      LQ2500  LQ2550
```

3. Select an emulation.

Repeatedly press MODE to position the cursor beneath the emulation you require. Then do one of the following:

- Press FF to underline (select) the emulation and print the next MENU1 or MENU2 item. As shown in Table 5.4, this is the item.

- Press LF to underline (select) the emulation and print <==END==>. Press LF again to print the last MENU1 or MENU2 item. As shown in Table 5.4, this is the <RGHTEND> item. Using LF is convenient when the options you need to change are near the end of the list of items.

NOTE

Whenever you select a new emulation, all MENU1 or MENU2 options are reset to the factory defaults for that emulation.

4. Change the other MENU1 or MENU2 options if required.

Press MODE to move the cursor to the option you want to select. Press FF to underline (select) the option and print the next item listed in Table 5.4. Press LF to underline (select) the option and print the previous item.

5. Exit MENU1 or MENU2.

Press ONLINE to exit the selected function and reprint the <<FUNCTION>> menu.

6. Do one of the following:

- **Select another function.**
- **Exit setup mode, saving your changes.**

For details about other functions, see the other sections in this chapter. To exit setup mode and save your changes, make sure the red cursor is positioned beneath SAVE&END. Press FF.

Resetting MENU 1 and MENU 2

To reset the factory defaults for both MENU 1 and MENU 2, select the DEFAULT function. For a detailed procedure, see **Resetting Defaults** later in this chapter. The printer's panel, hardware, and top-of-form options are not reset.

CHANGING HARDWARE OPTIONS

The HARDWRE function allows you to define the printer's hardware conditions. The following options must be set properly for the printer to function correctly with your system hardware:

- Serial interface options (for serial interface only)
- Type of cut sheet feeder, if installed

The HARDWRE items and options are listed in Table 5.5. Items are listed in the order in which they are printed. The procedure for changing the hardware options follows Table 5.5.

Table 5.5 HARDWRE Items and Options

NOTE: Underlined options are the factory defaults.

HARDWRE Items	Options	Description
<PPR-OUT>		Specifies how the printer responds when you run out of paper.
	<u>CN</u> ONLY	The printer detects paper-out only for continuous forms. Printing stops and PAPER OUT turns red.
	DETECT	The printer detects paper-out for both continuous forms and single sheets. Printing stops and PAPER OUT turns red.

Table 5.5 HARDWRE Items and Options (Cont.)

NOTE: Underlined options are the factory defaults.

HARDWRE Items	Options	Description
	IGNORE	The printer ignores paper-out for both continuous forms and single sheets. Printing continues until no more data remains. No PAPER OUT warning appears. NOTE: For cut sheet feeders, printing stops and PAPER OUT turns red, regardless of the PPR-OUT setting.
<PRT-DIR>	<u>BI-DIR</u> UNI-DIR	Bidirectional printing Unidirectional printing is useful for precision printing, such as vertical lines in tables. Printing is slower than bi-directional printing.
<BUZZER>	<u>ON</u> OFF	Turns the printer's status buzzer on or off. Buzzer on. This is the recommended setting. The printer beeps to indicate paper-out, installation or removal of a font card, and various other conditions. Buzzer off

Table 5.5 HARDWRE Items and Options (Cont.)

NOTE: Underlined options are the factory defaults.

HARDWRE Items	Options	Description
<WORD-LG>		To determine the required word length, refer to your computer documentation. Select 8-BIT when you print bit image graphics.
	<u>8 BIT</u>	8-bit word length. Used by most computers.
	7 BIT	7-bit word length
<BUFFER>		Download
		Print buffer buffer
	256BYTE	256 bytes 31.75K
	2KBYTE	2K 30K
	<u>8KBYTE</u>	8K 24K
24KBYTE	24K 8K	
		NOTE: For IBM XL24 emulation, print buffer is fixed to 256 bytes regardless of setting of this item. For LQ2500/2550 emulation with 24KBYTE selected, a download error will occur.
<FEEDER>		Tells the printer whether a cut sheet feeder is installed.
	<u>REAR</u>	No cut sheet feeder installed
	SINGLE	Single bin cut sheet feeder installed
	DOUBLE	Double bin cut sheet feeder installed
<p>Serial Interface Items. The following items are printed only when your printer has a serial interface. Be sure the options selected on the printer are the same as the options selected using your computer's operating system or your software. Refer to the documentation provided with your computer and your software.</p>		

Setup Mode

Table 5.5 HARDWRE Items and Options (Cont.)

NOTE: Underlined options are the factory defaults.

HARDWRE Items	Options	Description			
<FORMAT>		No. of data bits	Parity bit	No. of stop bits	
	<u>8NONE 1</u>	8	None	1	
	8NONE 2	8	None	2	
	8EVEN 1	8	Even	1	
	8 ODD 1	8	Odd	1	
	7EVEN 1	7	Even	1	
	7 ODD 1	7	Odd	1	
	7MARK 1	7	Mark	1	
	7SPACE1	7	Space	1	
	7EVEN 2	7	Even	2	
	7 ODD 2	7	Odd	2	
			<p>The data format includes a start bit.</p> <p>The mark parity bit is always logical 1.</p> <p>The space parity bit is always logical 0.</p>		
	<BAUD-RT>	150	Baud rate in bps (bits per second). Select the same baud rate as your computer or modem.		
300					
600					
1200					
4800					
<u>9600</u>					
19200					

Table 5.5 HARDWARE Items and Options (Cont.)

NOTE: Underlined options are the factory defaults.

HARDWARE Items	Options	Description
<PROTOCL>	<u>XON/XOF</u> DTR REV-CHL ETX/ACK	Data transmission protocol DC1 and DC3 codes are used. Data Terminal Ready signal is used. Reverse Channel signal is used. ETX and ACK codes are used.
<DSR>	<u>IGNORE</u> DETECT	DSR is ignored by the printer. DSR is detected by the printer.
<DUPLEX>	<u>FULL</u> HALF	Simultaneous data transmission in opposite directions Data transmission in either direction, but not simultaneously
<==END==>	—	Indicates the end of the HARDWARE item list. Press FF to print the first item, <PPR-OUT>. Press LF to print the previous item. Press ONLINE to reprint the <<FUNCTION>> menu.

Setup Mode

√ Procedure

To change the printer's hardware options, make sure continuous forms paper is loaded. Then take the following steps.

1. Enter setup mode.

While pressing MODE, turn the printer on. Wait for the printer to stop printing and check that the <<FUNCTION>> menu is printed:

```

<<FUNCTION>>
SAVE&END PANEL  MENU1  MENU2  HARDWRE          LIST  DEFAULT  SELF-TST  HEX-DUMP  V-ALMNT
TOP-ADJ
    
```

2. Select the HARDWRE function.

Repeatedly press MODE to position the red cursor beneath HARDWRE. Press FF to underline (select) HARDWRE and print the first item and its options:

```

< PPR-OUT >          CNTONLY  DETECT          IGNORE
    
```

3. Select an option for the selected item.

Press MODE to move the cursor to the option you require. Press FF to underline (select) the option and print the next item.

NOTE

To print the previous item, press LF.

4. Repeat step 3 until all required options are changed.

5. Exit HARDWRE.

Press ONLINE to exit the HARDWRE function and reprint the <<FUNCTION>> menu.

6. Do one of the following:

- Select another function.
- Exit setup mode, saving your changes.

For details about other functions, see the other sections in this chapter. To exit setup mode and save your changes, make sure the red cursor is positioned beneath SAVE&END. Press FF.

CHANGING TOP-OF-FORM

The top edge of your paper is the *physical* top of the page. The *logical* top of the page, as “understood” by the printer when loading paper, is called its top-of-form setting. The TOF-ADJ function allows you to tell the printer where it should establish top-of-form. Printing will start at the position obtained by adding the following:

- Top-of-form setting
- Top margin specified by your software
- The printer’s TOP-MRG (top margin) setting

The printer’s top-of-form setting can be either 1/6 inch (4.2 mm) or 1 inch (25.4 mm). You can also fine-adjust the top-of-form setting. The factory default is 1 inch.

The TOF-ADJ items and options are listed in the Table 5.6. Items are listed in the order in which they are printed. The procedure for changing top-of-form follows Table 5.6.

Table 5.6 TOF-ADJ Items and Options

NOTE: Underlined options are the factory defaults.

TOF-ADJ Items	Options	Description
<ORIGIN>	1/6INCH	Sets top-of-form to 1/6 inch from the top of the physical page. This setting is recommended when your top margin is software-specified.
	<u>1 INCH</u>	Sets top-of-form to 1 inch from the top of the physical page. This setting is recommended if your top margin is not software-specified.
<FINEADJ>		Fine-adjusts the top-of-form setting in increments of 1/60 inch (.42 mm).
	-7/60IN, ..., -1/60IN	Decreases top-of-form slightly.
	0 +1/60IN, ..., +8/60IN	Increases top-of-form slightly.
<==END==>	—	Indicates the end of the TOF-ADJ item list. Press FF to print the first item, <ORIGIN>. Press LF to print the last item, <FINEADJ>. Press ONLINE to reprint the <<FUNCTION>> menu.

√ Procedure

To change the top-of-form setting, make sure continuous forms paper is loaded. Then take the following steps.

1. Enter setup mode.

While pressing MODE, turn the printer on. Wait for the printer to stop printing and check that the <<FUNCTION>> menu is printed:

```
<<FUNCTION>>
SAVE&END PANEL  MENU1  MENU2  HARDWRE      LIST  DEFAULT  SELF-TST  HEX-DUMP  V-ALMNT
TOP-ADJ
```

Setup Mode

2. Select the TOF-ADJ function.

Repeatedly press MODE to position the red cursor beneath TOF-ADJ. Press FF to underline (select) TOF-ADJ and print the <ORIGIN> options:

```
<ORIGIN >      1/6INCH  1 INCH
```

3. Select 1/6 inch or 1 inch.

Press MODE to move the cursor to either 1/6 inch (4.2 mm) or 1 inch (25.4 mm). Press FF to underline (select) the option. The <FINEADJ> item will be printed. If you know you need to fine-adjust top-of-form, you may do so now. Otherwise, go to step 4.

4. Exit TOF-ADJ.

Press ONLINE to exit the TOF-ADJ function and reprint the <<FUNCTION>> menu.

5. Exit setup mode, saving the top-of-form setting.

Make sure the red cursor is positioned beneath SAVE&END.
Press FF.

6. Check the top-of-form setting.

Load a sheet of paper and print a sample page using your software. If necessary, re-enter setup mode and fine-adjust top-of-form by changing the <FINEADJ> option.

EXITING AND SAVING

There are two different methods to exit setup mode and save any changes you made. Briefly, these methods are:

- To exit setup mode immediately, select the SAVE&END function.
- To print the self-test before exiting setup mode, select the SELF-TST function. Then exit setup mode by pressing ONLINE.

With either method, any settings you changed while in setup mode are saved as the printer's new power-on defaults. The new defaults remain active until you change them again.

NOTE

The only way to exit setup mode without saving your changes is to turn off the printer. When you turn the printer back on, its previous default settings will be active.

√ **Procedure**

To exit setup mode and save your changes using SELF-TST, see **Printing the Self-Test** later in this chapter. To exit setup mode and save your changes using SAVE&END, follow these steps.

1. Print the <<FUNCTION>> menu.

The <<FUNCTION>> menu should be the last printed line on the page. If it isn't, press ONLINE to print it. (If using the SELF-TST or HEX-DUMP function, press FF instead of ONLINE to print the <<FUNCTION>> menu.)

```

<<FUNCTION>>
SAVE&END PANEL  MENU1  MENU2  HARDWRE      LIST  DEFAULT  SELF-TST  HEX-DUMP  V-ALMNT
TOP-ADJ
    
```

2. Select the SAVE&END function.

Check that the red cursor is positioned beneath SAVE&END. Press FF to underline (select) SAVE&END. The printer exits setup mode and returns online (the ONLINE indicator turns green). Any changes you made while in setup mode are saved.

Setup Mode

RESETTING DEFAULTS

This section describes how to reset the printer's power-on defaults, all of the factory defaults, or the factory defaults only for MENU 1 and MENU 2.

Resetting Power-On Defaults

Power-on defaults are those settings saved in the printer's permanent memory. The defaults are active whenever you turn the printer on. The easiest way to reset the power-on defaults is to turn the printer off and on. This is useful if you have made changes in setup mode which you do not want to save.

Resetting Factory Defaults

Factory defaults are those settings preselected at the factory. For a list of the printer's factory defaults, see **Printing a List of Selected Options** earlier in this chapter. To reset the factory defaults for all functions, follow these steps.

1. Turn off the printer.
2. While pressing both the MODE and LF buttons, turn on the printer. Continue to press MODE and LF until the printer beeps.

The factory defaults are now reset.

Resetting Factory Defaults in MENU 1 and MENU 2

Factory defaults for MENU 1 and MENU 2 are listed in Table 5.4. To reset the factory defaults only in MENU 1 and MENU 2, use the following procedure. The printer's panel, hardware, and top-of-form options are not reset.

1. Enter setup mode.

While pressing MODE, turn the printer on. Wait for the printer to stop printing and check that the <<FUNCTION>> menu is printed:

```

<<FUNCTION>>
SAVE&END PANEL  MENU1  MENU2  HARDWARE      LIST  DEFAULT  SELF-TST  HEX-DUMP  V-ALMNT
TOP-ADJ
```

2. Select the DEFAULT function.

Repeatedly press MODE to position the red cursor beneath DEFAULT. Press FF to underline (select) DEFAULT and reprint the <<FUNCTION>> menu. The default values in MENU 1 and MENU 2 are reset.

3. Do one of the following:

- Select new options for MENU 1 or MENU 2.
- Exit setup mode, saving the factory defaults.

See **Changing MENU 1 and MENU 2 Options**. To exit setup mode and save the new defaults, make sure the red cursor is positioned beneath SAVE&END. Press FF.

USING THE DIAGNOSTIC FUNCTIONS

This section describes how to use the printer's diagnostic functions:

- SELF-TST
- HEX-DUMP
- V-ALMNT

These functions are helpful for checking print quality and diagnosing printer problems. HEX-DUMP is also useful to programmers.

Printing the Self-Test

The SELF-TST function allows you to print test pages to check how the printer operates independent of your computer. The self-test does not check the interface between the computer and the printer.

The self-test prints the printer's firmware version, its resident emulations, and all of the characters available in the currently selected character set. For color printers with a color ribbon, printing occurs in seven colors. If the DPL24C PLUS emulation is selected for MENU 1,

the self-test is printed using the settings currently assigned to MENU 1. For example, if Prestige Elite 12 and italics are selected, the self-test will print using Prestige Elite 12 and italics. This is a convenient way to see how printing from MENU 1 will look.

√ **Procedure**

This procedure assumes you are in setup mode. To print the self-test, make sure continuous forms paper is loaded into the printer. Then follow these steps.

1. Print the <<FUNCTION>> menu.

The <<FUNCTION>> menu should be the last printed line on the page. If it isn't, press ONLINE to print it. (If using the HEX-DUMP function, press FF instead of ONLINE to print the <<FUNCTION>> menu.)

```

<< FUNCTION >>
SAVE&END PANEL  MENU1  MENU2  HARDWRE          LIST  DEFAULT  SELF-TST  HEX-DUMP  V-ALMNT
TOP-ADJ
    
```

2. Select the SELF-TST function.

Repeatedly press MODE to position the red cursor beneath SELF-TST. Press FF. The printer underlines (selects) SELF-TST and starts printing. A short Help menu is printed at the top of the page, followed by the self-test. Note that the printer *does not go online* during self-test printing.

3. Examine the self-test page.

To pause self-test printing, press MODE or LF. A sample self-test page is shown in Chapter 2. To resume self-test printing, press MODE or LF again.

4. Exit SELF-TST.

To exit the SELF-TST function, do one of the following:

- To exit SELF-TST and remain in setup mode, press FF. The <<FUNCTION>> menu will be reprinted.
- To exit SELF-TST and return online, press ONLINE. The printer permanently saves any changes you made while in setup mode and returns you online ready to print.

An alternate way to start self-test printing is to turn off the printer, then press the FF button while turning the printer back on. As described in Chapter 2, this method is convenient when you first set up the printer.

Printing Hex Dumps

The HEX-DUMP function allows you to print data and commands in hexadecimal characters and abbreviated control codes. The character set used for printing is IBM character set 2, shown in Appendix B of the programmer's manual. This is useful for checking whether your computer is sending the correct commands to the printer and whether the printer is executing the commands correctly. It is also useful for debugging software programs.

√ Procedure

To print hex dumps, make sure continuous forms paper is loaded into the printer. Then follow these steps.

1. Enter setup mode.

While pressing MODE, turn the printer on. Wait for the printer to stop printing and check that the <<FUNCTION>> menu is printed:

```

<<FUNCTION>>
SAVE&END PANEL  MENU1  MENU2  HARDWRE      LIST  DEFAULT  SELF-TST  HEX-DUMP  V-ALMNT
TOP-ADJ
    
```

2. Select the HEX-DUMP function.

Repeatedly press MODE to position the red cursor beneath HEX-DUMP. Press FF to underline (select) HEX-DUMP. The printer goes *online* and prints a header and a short Help menu.

3. Print the hex dump.

To start hex dump printing, send your file or program to the printer. The printer goes online and prints the hex dump. A sample hex dump is shown in the following figure.

Press LF or MODE to pause hex dump printing. To resume hex dump printing, press LF or MODE again.

```

<<FUNCTION>>
  SAVE&END  PANEL  MENU1  MENU2  HARDWARE
  TOP-ADJ

LIST  DEPAULT  SELP-FST  HEX-DUMP  V-ALMNT

*** Hex dump printing ***

BUTTON  ACTION
<ONLINE>  Exit to normal mode
< F F >  Return to <<FUNCTION>> menu
< L F >  Pause/resume printing
< MODE >  Pause/resume printing

0  1  2  3  4  5  6  7  8  9  A  B  C  D  E  F  0123456789ABCDEF
1B 25 00 00 1B 68 12 1B 43 42 1B 4A C4 1B 24 68  %*hCBBJ- Sh
01 41 42 43 44 45 46 47 48 49 4A 4B 4C 4D 4E 4F  ABCDEFGHIJKLMNO
50 51 52 53 54 55 56 57 58 59 5A 1B 4A 1E 1B 24  PQRSTUVWXYZJES
68 01 61 62 63 64 65 66 67 68 69 6A 6B 6C 6D 6E  habcdefghijklmn
6F 70 71 72 73 74 75 76 77 78 79 7A 1B 4A 1E 1B  opqrstuvwxyzJES
24 68 01 30 31 32 33 34 35 36 37 38 39 0C 1B 72  Sh0123456789#r
00
  
```

Setup Mode

Sample hex dump

NOTE

When hex dump printing stops, the printer remains online in setup mode (the ONLINE indicator is green). To print another hex dump, send another file to the printer.

4. Exit HEX-DUMP.

To exit the HEX-DUMP function, do one of the following:

- To exit HEX-DUMP and remain in setup mode, press FF. The <<FUNCTION>> menu will be reprinted. For details about other functions, see the other sections in this chapter.
- To exit HEX-DUMP and return to online normal mode, press ONLINE. If you press ONLINE while the hex dump is printing, printing continues but the printer switches from hexadecimal format to standard characters.

An alternate way to print hex dumps is as follows:

- Turn off the printer.
- While simultaneously pressing the FF and LF buttons, turn the printer back on. Continue pressing FF and LF until the printer beeps.
- Send your file or program to the printer. Hex dump printing will start.

Checking Vertical Print Alignment

The V-ALMNT function allows you to correct the vertical character displacement that sometimes occurs with bidirectional printing. Characters printed from left to right become misaligned with the characters printed from right to left. An example of vertical displacement follows:

```
This example shows how printing looks  
when characters are vertically  
misaligned. Note that the left  
margin is not straight.
```

If you notice misaligned printing, use the following procedure to check and correct the vertical print alignment.

√ Procedure

Make sure continuous forms paper is loaded into the printer. If possible, use forms at least 279 mm (11 inches) wide to avoid printing on the platen. However, you can also use forms of letter or A4 size by setting the WIDTH option in MENU 1 to 8 inches. See **Changing MENU 1 and MENU 2 Options** for details. Follow these steps to check and correct vertical print alignment.

1. Enter setup mode.

While pressing MODE, turn the printer on. Wait for the printer to stop printing and check that the <<FUNCTION>> menu is printed:

```

<<FUNCTION>>
SAVE&END PANEL  MENU1  MENU2  HARDWRE          LIST  DEFAULT  SELF-TST  HEX-DUMP  V-ALMNT
TOP-ADJ
    
```

Setup Mode

2. Select the V-ALMNT function.

Repeatedly press MODE to position the red cursor beneath V-ALMNT. Press FF to underline (select) V-ALMNT. The printer starts printing rows of parallel bars using letter quality speed.

3. Adjust the vertical print alignment at letter quality speed.

Look at the parallel bars. If the bars are aligned (not jagged), go to step 4. If the bars are offset to the left (see following figure), repeatedly press MODE until the bars are aligned. If the bars are offset to the right (see following figure), repeatedly press LF until the bars are aligned.



Bars offset to left

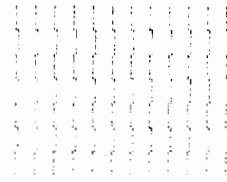

Bars offset to right

4. Adjust the vertical print alignment at correspondence speed.

Press FF to switch from letter speed to correspondence speed.

Look at the parallel bars. If the bars are aligned (not jagged), go to step 5. If the bars are offset to the left, repeatedly press MODE until the bars are aligned. If the bars are offset to the right, repeatedly press LF until the bars are aligned.

5. Adjust the vertical print alignment at draft speed.

Press FF to switch from correspondence speed to draft speed.

Look at the parallel bars. If the bars are aligned (not jagged), go to step 6. If the bars are offset to the left, repeatedly press MODE until the bars are aligned. If the bars are offset to the right, repeatedly press LF until the bars are aligned.

6. Exit V-ALMNT.

Press ONLINE to exit the V-ALMNT function and save the new vertical alignment settings. The printer exits setup mode and returns online.

NOTE

To exit the V-ALMNT function, you must exit setup mode.

DPL24C PLUS ORGANIZATION

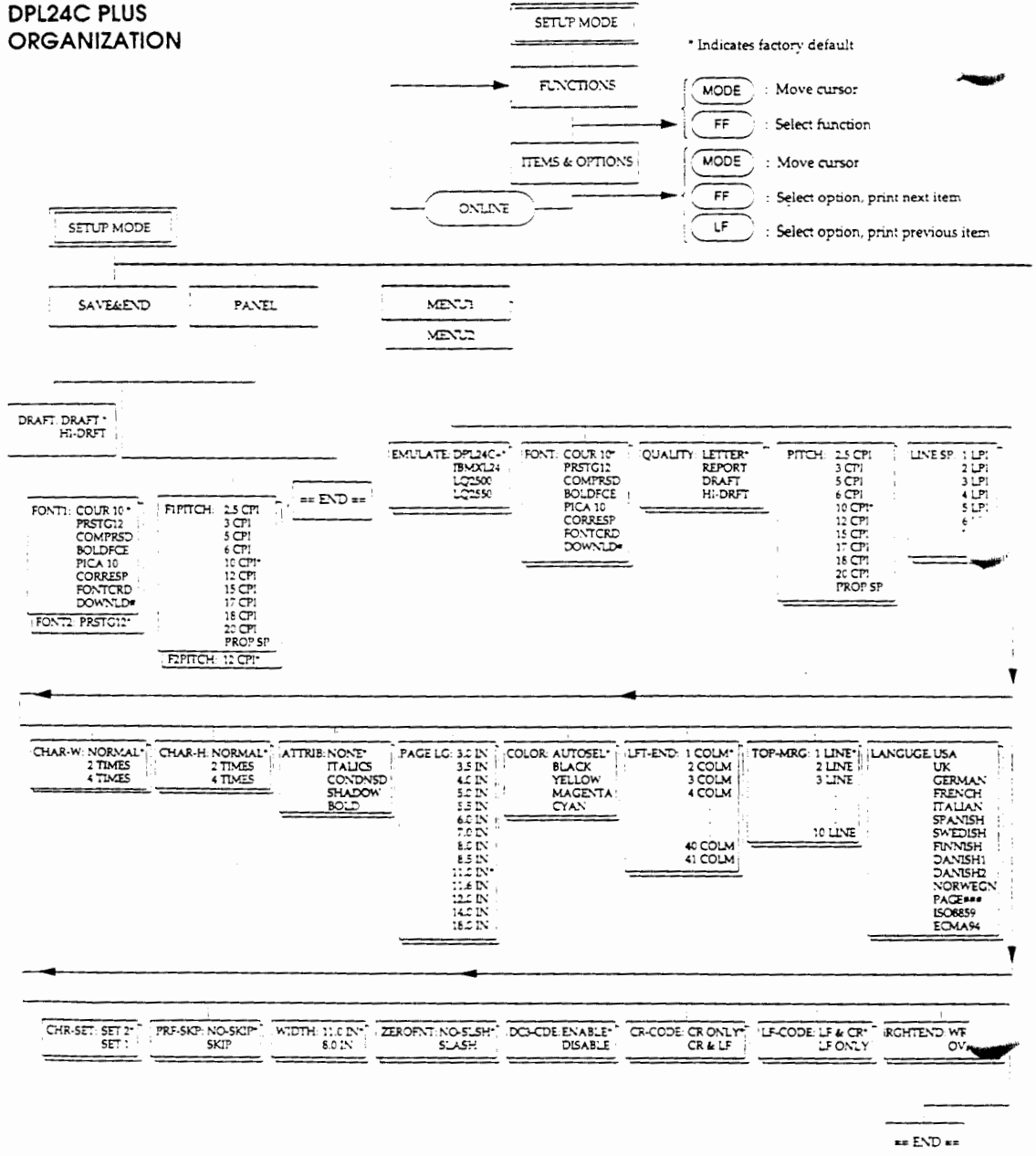

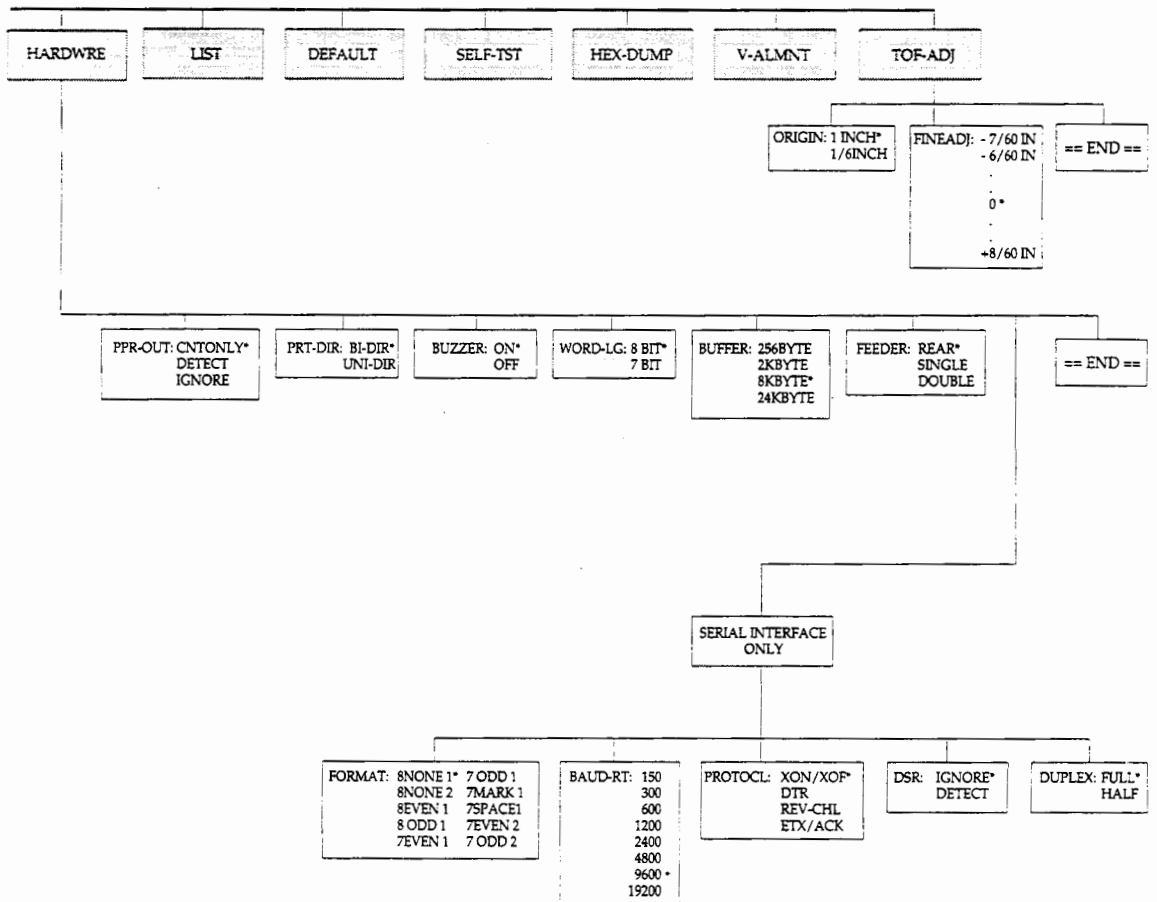

Setup Mode

Differences for IBM Proprinter XL24 Emulation

In the IBM Proprinter XL24 emulation, MENU1 and MENU2 differ from the DPL24C PLUS emulation in the following ways:

- The following options are different:

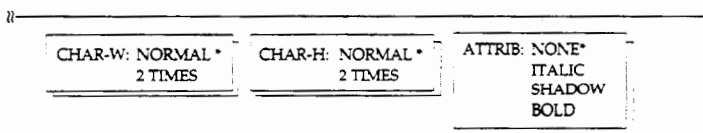

- The AGM item is provided:

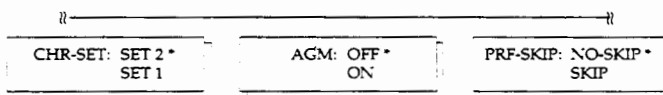

Differences for Epson LQ-2500/-2550 Emulation

In the Epson LQ-2500/-2550 emulations, MENU1 and MENU2 differ from the DPL24C PLUS emulation in the following ways:

- The ZEROFNT and LF-CODE items are not defined.
- The following options are different:

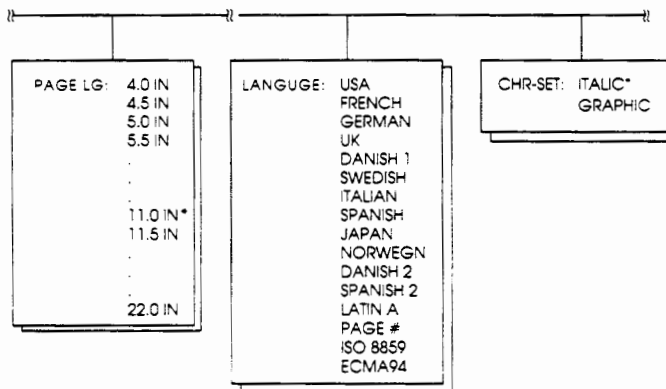

6

MAINTENANCE

Your printer requires very little care. Occasional cleaning and replacement of the ribbon cartridge are all that's required.

Lubrication of the printer is not usually necessary. If the print head carriage does not move smoothly back and forth, clean the printer using the procedures in this chapter. If the problem continues, contact your dealer to determine whether lubrication might be needed.

CLEANING

The front and top covers of the printer help protect it from dust and dirt. However, paper produces small particles which accumulate inside the printer. This section explains how to clean and vacuum the printer, and how to clean the platen and paper bail rollers.

Cleaning and Vacuuming the Printer

WARNING

To avoid any possibility of injury, turn off the power to both the printer and the computer and unplug the printer before cleaning.

Use the following procedure to clean and vacuum the printer as required.

1. Remove any paper loaded into the printer. Be sure the printer power cord is unplugged and the power is off.
2. Using a soft vacuum brush, vacuum the exterior of the printer. Be sure to vacuum the air vents at the sides and rear of the printer. Also vacuum the cut sheet stand or feeder.
3. Use a soft, damp cloth to wipe the exterior of the printer, including the front and top covers. A mild detergent may be used.

CAUTION

Do not use solvents or abrasive cleaning materials that may damage the printer.

4. Open the front and top covers of the printer and remove the ribbon cartridge. Using a soft vacuum brush, gently vacuum the platen, print head carriage, and surrounding areas. Be careful not to press too hard on the flat ribbon cable extending from the print head carriage (see the following figure).

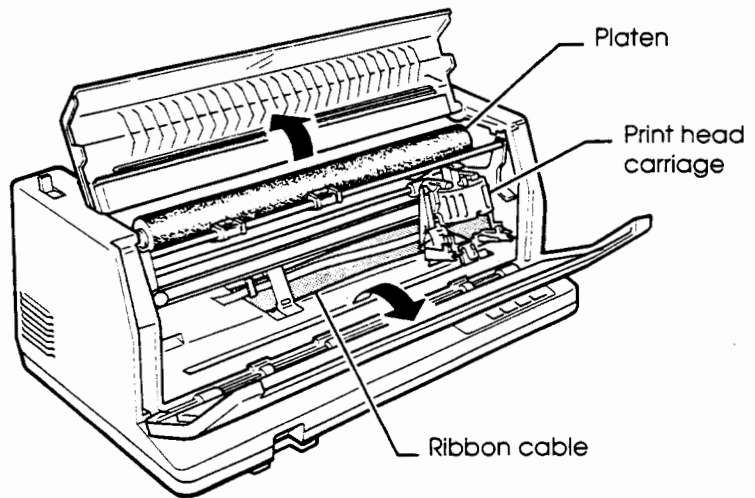

Printer interior

5. Reinstall the ribbon cartridge. Close the front and top covers.
6. Raise the cut sheet stand. Vacuum the rear forms tractors and surrounding areas.

Cleaning the Platen and Paper Bail Rollers

To remove excess ink from the platen and paper bail rollers, clean them about once a month. Obtain the platen cleaner recommended by your supplier and follow these steps.

1. Apply a small amount of platen cleaner to a soft cloth. Avoid getting platen cleaner inside the printer.

CAUTION

Do not use alcohol to clean the platen. Alcohol may cause the rubber to harden.

2. Place the cloth against the platen and manually rotate the platen knob.
3. To dry the platen, place a dry cloth against it while rotating the platen knob.
4. Gently wipe the paper bail rollers using the cloth containing the platen cleaner. Dry the rollers with a dry cloth.

**REPLACING THE
RIBBON CARTRIDGE**

A color printer can use either a color or black ribbon cartridge. A monochrome printer *requires* a black ribbon cartridge. Appendix A lists order numbers for ribbon cartridges.

To replace the ribbon cartridge:

1. Turn off the printer.
2. Open the top and front covers of the printer. For easy access to the print head carriage, slide it about three quarters of the way to the right side of the platen.

CAUTION

Print head may be hot if you've been printing recently.

3. Move the paper thickness lever to the *down* position, as shown in the figure below.

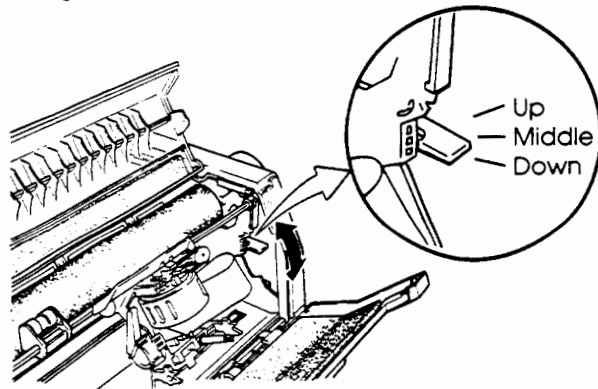

Paper thickness lever

4. To remove the old ribbon cartridge, press in the ribbon release levers on either side of the cartridge. As you press in the levers, gently lift the cartridge out of the printer.

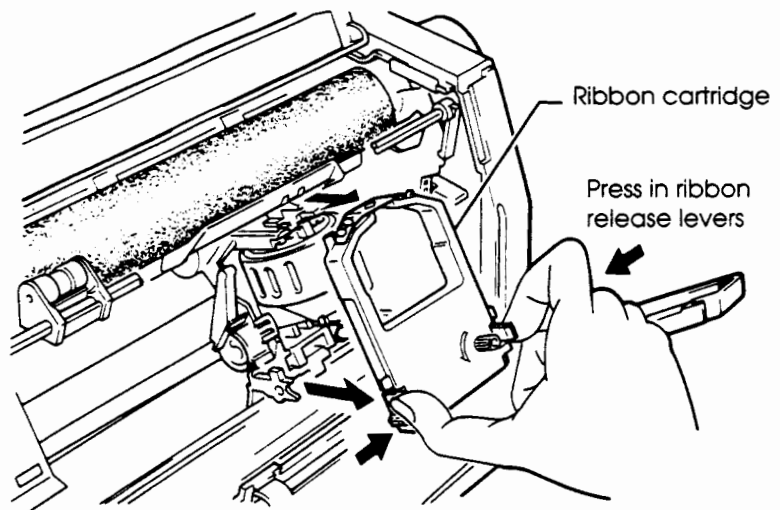

Removing the old ribbon cartridge

5. Remove the new ribbon cartridge from its package. If the ribbon is color, remove the red stopper releasing the ribbon feed knob (see the following figure). Turn the ribbon feed knob **COUNTERCLOCKWISE** to be sure it feeds properly.

NOTE

If using a black ribbon, do not remove the small strip of plastic covering the ribbon. This is the *ribbon mask*, used to protect the ribbon.

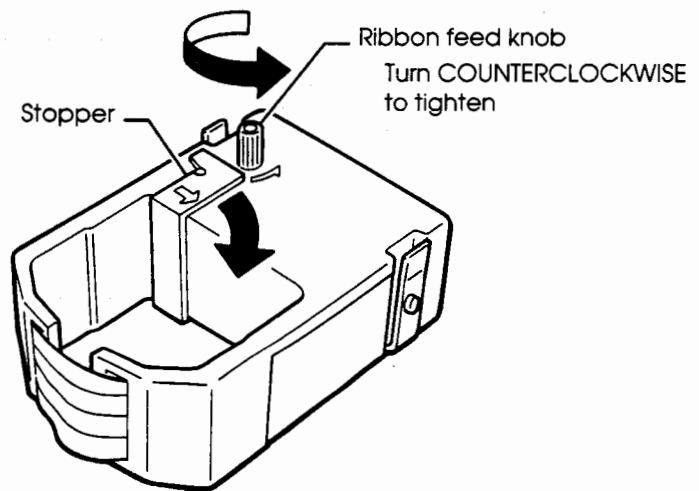
**Preparing the new ribbon cartridge**

6. Referring to the following figure, place the two mounting pins (on the sides of the ribbon release levers) onto the ribbon support studs inside the printer. Rotate the cartridge so the ribbon falls between the nose of the print head and the plastic print guide.

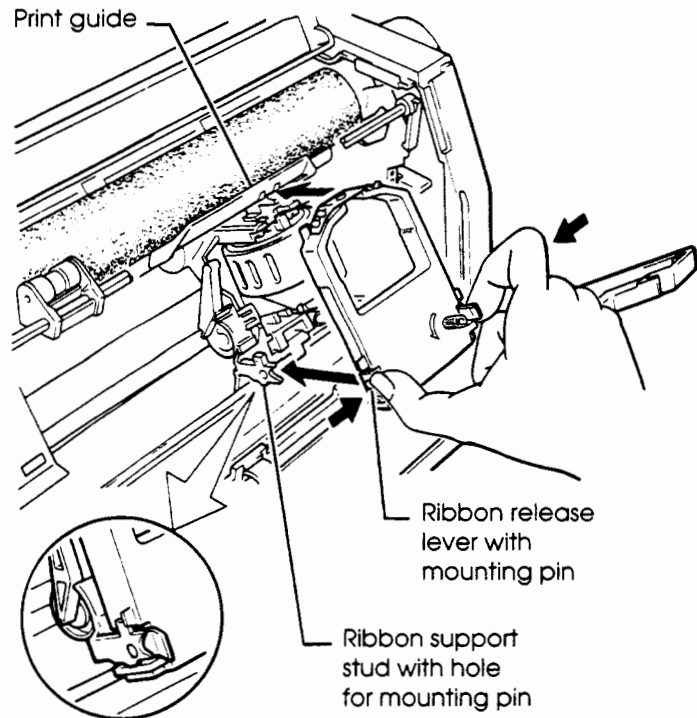

Installing the new ribbon cartridge

7. Press in the ribbon release levers until the mounting pins snap into the holes on the ribbon support studs. Gently pull on the cartridge to verify that the pins are securely installed in the holes.
8. Turn the ribbon feed knob COUNTERCLOCKWISE to tighten the ribbon.
9. Move the paper thickness lever (inside the right side of the printer) back to its original position. For single sheet printing, the correct position is *up*. Table 3.1 in Chapter 3 gives other paper thickness lever settings.
10. Close the top and front covers of the printer.

7

PROBLEM SOLVING

Your printer is extremely reliable, but occasional problems may occur. You can solve many of these problems yourself, using this chapter. For problems you cannot resolve, contact your dealer for assistance. This chapter is organized as follows:

- Problems and solutions
- Diagnostic functions
- Getting help

PROBLEMS AND SOLUTIONS

The tables in this section list common printer problems and their solutions. The following types of problems are listed:

- Printing problems
- Paper handling problems
- Operational problems

Printing Problems

Poor print quality or other printing problems are often caused by incorrect printer setup or incorrect software settings. A gradual decrease in print quality usually indicates a worn ribbon. Table 7.1 lists common printing problems and their solutions.

Table 7.1 Printing Problems and Solutions

Problems	Solutions
<p>Printing is too light or too dark.</p>	<p>Make sure the ribbon cartridge is properly installed, and that the ribbon feeds smoothly.</p> <p>Make sure the paper thickness lever is set for the thickness of your paper. See Table 3.1 in Chapter 3.</p> <p>The ribbon may be worn. Replace the ribbon.</p>
<p>Stains or smudges appear on the page.</p>	<p>Make sure the paper thickness lever is set for the thickness of your paper. See Table 3.1 in Chapter 3.</p> <p>The ribbon may be worn. Replace the ribbon.</p> <p>Check whether the tip of the print head is dirty. Clean it with a soft cloth.</p>
<p>The page is blank.</p>	<p>Make sure the ribbon cartridge is properly installed.</p>
<p>Printing is erratic or the wrong characters are printed. Many "?" characters are printed.</p>	<p>Make sure the interface cable is securely connected to both the printer and computer.</p> <p>Make sure the printer emulation selected in your software is the same as the emulation selected on the printer. See Selecting an Emulation in Chapter 2.</p> <p>If using an RS-232C serial interface, make sure the serial settings required by your software or computer are the same as the settings on the printer. See Changing Hardware Options in Chapter 5.</p>

Table 7.1 Printing Problems and Solutions (Cont.)

Problems	Solutions
Printing is vertically misaligned (jagged).	Use the printer's V-ALMNT function to check the vertical print alignment. If necessary, adjust the print alignment. See Using the Diagnostic Functions in Chapter 5.
The top margin is wrong.	<p>The top margin is the sum of the top-of-form setting, the software-specified top margin, and the printer's TOP-MRG setting. Check the following:</p> <ul style="list-style-type: none"> • Make sure the top-of-form setting is correct. The possible default settings are 25.4 mm (1 inch) and 4.2 mm (1/6 inch). See Changing Top-of-Form in Chapter 5. • Check the top margin specified using your software. Refer to your software documentation. • Check the printer's TOP-MRG setting. See Changing MENU 1 and MENU 2 Options in Chapter 5.
Lines are double spaced instead of single spaced.	<p>Check the line spacing setting in your software.</p> <p>Change the CR-CODE setting in the printer's setup mode to CR ONLY. See Changing MENU 1 and MENU 2 Options in Chapter 5.</p>
The printer keeps printing on the same line.	Change the CR-CODE setting in the printer's setup mode to CR & LF. See Changing MENU 1 and MENU 2 Options in Chapter 5.
The next print line starts where the previous line ended instead of at the left margin.	Change the LF-CODE setting in the printer's setup mode to LF & CR. See Changing MENU 1 and MENU 2 Options in Chapter 5.

Paper Handling Problems

Table 7.2 lists common paper handling problems and their solutions. See Chapter 3 for detailed procedures on loading and using paper.

Table 7.2 Paper Handling Problems and Solutions

Problems	Solutions
Paper cannot be loaded.	<p>Make sure the paper select lever is set correctly. Move the lever forward for continuous forms, backward for single sheets.</p> <p>Make sure your paper covers the paper-out sensor (the groove on the left side of the platen).</p> <p>If using a cut sheet feeder, make sure the bin lever (on the left side of the feeder) is set down to "CLOSED."</p> <p>If using a cut sheet feeder, make sure that FEEDER was set correctly in setup mode. Specify SINGLE for a single bin feeder or DOUBLE for a double bin feeder. See Changing Hardware Options in Chapter 5.</p>
Paper jams while loading.	<p>Turn off the printer and remove the jammed paper. Remove any obstructions from the paper path.</p> <p>Make sure the paper thickness lever is set for the thickness of your paper. See Table 3.1 in Chapter 3.</p> <p>If using a cut sheet feeder, make sure the bin lever (on the left side of the feeder) is set down to "CLOSED."</p> <p>Make sure the paper is not folded, creased, or torn. Reinstall the paper.</p>

Table 7.2 Paper Handling Problems and Solutions (Cont.)

Problems	Solutions
<p>Paper jams while printing.</p>	<p>Turn off the printer and remove the jammed paper. Remove any obstructions from the paper path.</p> <p>Make sure the paper thickness lever is set for the thickness of your paper. See Table 3.1 in Chapter 3.</p> <p>For continuous forms, make sure the ingoing and outgoing paper stacks are correctly placed. Paper should feed in a straight line.</p> <p>If using a cut sheet feeder, make sure the bin lever (on the left side of the feeder) is set down to "CLOSED."</p> <p>Reinstall the paper.</p>
<p>Paper slips off the forms tractors. Or the perforated holes of the paper are broken during printing.</p>	<p>Make sure the forms tractors are positioned for the width of your paper, and the perforated holes of the paper fit directly over the tractor sprockets.</p>

Problem Solving

Operational Problems

Table 7.3 lists common operational problems and their solutions. If you cannot resolve a problem, contact your dealer.

Table 7.3 Operational Problems and Solutions

Problems	Solutions
<p>The power does not turn on.</p>	<p>Make sure the "1" on the printer's power switch is toggled up.</p> <p>Make sure the power cord is securely connected to both the printer and the outlet. Make sure the power outlet is functional.</p> <p>Turn the power off. Wait 30 seconds and turn the printer on again. If the printer still has no power, contact your dealer.</p>
<p>The printer is on but will not print.</p>	<p>Make sure the printer is online.</p> <p>Make sure the interface cable is securely connected to both the printer and the computer.</p> <p>Check whether the red PAPER OUT indicator is lit. If so, load paper.</p> <p>Run the printer's self-test (see Chapter 5). If the self-test executes normally, the problem is caused by the interface, the computer, incorrect printer settings, or incorrect software settings.</p> <p>Make sure the printer emulation selected in your software is the same as the emulation selected on the printer. See Selecting an Emulation in Chapter 2.</p>

Table 7.3 Operational Problems and Solutions (Cont.)

Problems	Solutions
	<p>If using an RS-232C serial interface, make sure the serial settings required by your software or computer are the same as the settings on the printer. See Changing Hardware Options in Chapter 5.</p>
<p>The printer beeps four times and the red PAPER OUT indicator keeps blinking.</p>	<p>The printer hardware, a font card, or an emulation card is defective. If a font or emulation card is installed, remove the card and use a soft brush to clean the gold contacts. Reinsert the card and turn the printer on. If the problem continues, contact your dealer.</p>
<p>The cut sheet feeder does not operate.</p>	<p>Make sure the cut sheet feeder is firmly mounted on the printer.</p> <p>Make sure that FEEDER was set correctly in setup mode. Specify SINGLE for a single bin feeder or DOUBLE for a double bin feeder. See Changing Hardware Options in Chapter 5.</p>

Problem Solving

DIAGNOSTIC FUNCTIONS

The printer's diagnostic functions are SEFT-TST, HEX-DUMP, and V-ALMNT.

- SELF-TST tells you whether the printer hardware is functioning correctly. If the printer hardware is functional, any problems you are having are probably caused by incorrect printer settings, incorrect software settings, the interface, or the computer.
- HEX-DUMP allows you to determine whether the computer is sending the correct commands to the printer, and whether the printer is executing the commands correctly. This function is useful to programmers or others who understand how to interpret hex dumps.
- V-ALMNT allows you to check and, if necessary, correct the printer's vertical print alignment.

For details on using these functions, all of which are available in the printer's setup mode, see Chapter 5.

GETTING HELP

If you are not able to correct a problem using this chapter, contact your dealer for assistance. Be prepared to provide the following information:

- Your printer's model number, serial number, and date of manufacture. Look for this information on the nameplate at rear of the printer.
- Description of the problem
- Type of interface you are using
- Names of your software packages
- List of the printer's default settings. To print the default settings, see Chapter 5.

INSTALLING OPTIONS

By installing options, you can expand the capabilities of your printer. Options available for the printer include:

- Single bin cut sheet feeder
- Double bin adapter for cut sheet feeder
- Envelope adapter for cut sheet feeder
- Font cards
- Emulation cards
- Serial interface board
- Color kit (unavailable in the U.S.A. and some other countries)

All options except color kits can be purchased from your dealer and installed by you. This chapter describes how to install each option. See Appendix A for order numbers.

INSTALLING A CUT SHEET FEEDER

A cut sheet feeder allows you to automatically print on single sheets without inserting the sheets one by one. A double bin adapter and an envelope adapter are also available.

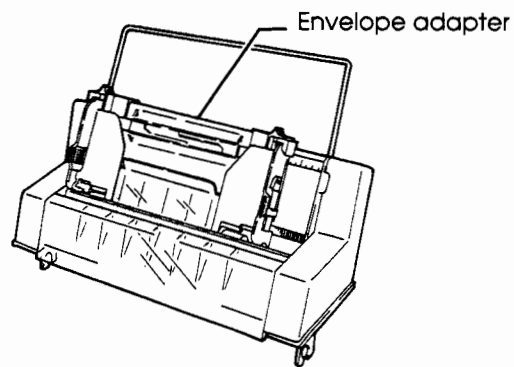

Single bin cut sheet feeder with envelope adapter

To mount a cut sheet feeder on your printer, refer to the manual shipped with the feeder. After the feeder is mounted, you must enter the printer's setup mode and specify either SINGLE or DOUBLE as the feeder type. Otherwise, the feeder will not work. To enter setup mode and specify the feeder type, see **Changing Hardware Options** in Chapter 5.

For details on using your cut sheet feeder, see Chapter 3.

INSTALLING/REMOVING FONT CARDS

In addition to the printer's eight resident fonts, you can use other fonts by installing font cards. Only one font card can be used at a time.

Font cards currently available include:

- Dutch 801™*, Script*, Old English, Humanist 521™*
- Swiss 721™*, Script*, Old English, Humanist 521™*
- Deluxe Courier*, Light Italic 12, Orator 10
- Deluxe Prestige*, Light Italic 12, Letter Gothic 12
- OCR-A, OCR-B, Scientific 12/18

*Licensed from Bitstream Inc., Cambridge, Massachusetts

For the latest information on font cards, contact your dealer. Appendix A in the programmer's manual provides examples showing how each font looks.

Installing a Font Card

When handling font cards, take the following precautions:

- Always store font cards in their electrostatic-proof cases. Static electricity and magnets can alter the information stored on font cards.
- Do not touch the font card's gold connectors. Dirt, dust, oil, or perspiration may damage the card.

To install a font card, turn on the printer and follow these steps.

1. Remove the font card from its case, being careful not to touch the gold connectors. Check that the label "For 24-wire Printers" appears on the card.

CAUTION

Do not use a font card designed for any other printer type.

2. Turn the font card so the "FONT CARD" label faces up and the arrow points towards the printer. Insert the font card into the card slot on the front left side of the printer.

If the card is correctly inserted, the printer will beep twice. (The printer won't beep if you deactivated BUZZER in setup mode.)

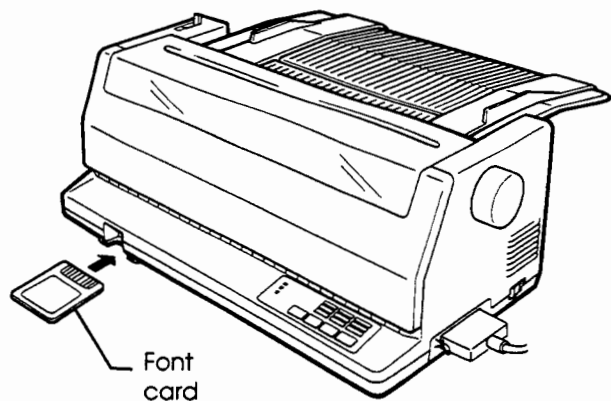

Inserting the font card

To select fonts on font cards, you can use either your software or the printer's control panel. To select fonts using software, refer to your software documentation. To select fonts using the control panel, you must first enter the printer's setup mode and assign the font options you require to MENU 1, MENU 2, FONT 1, and FONT 2 on the

printer's control panel (see Chapter 5 for details). After you save your font options and exit setup mode, you can select fonts from the control panel as described in Chapter 4.

Removing a Font Card

To remove a font card, pull it out of the card slot. If the printer is on, it will beep twice when the card is removed. (The printer won't beep if you deactivated BUZZER in setup mode.)

Return the font card to its electrostatic-proof case. Be careful not to drop or bend the card.

INSTALLING/REMOVING EMULATION CARDS

In addition to the printer's four resident emulations, you can use other emulations by installing emulation cards. Only one emulation card can be used at a time.

Emulation cards currently available include:

- Fujitsu DPL24D (for Diablo 630 compatibility)
- DEC LA50/75/120/210

Installing an Emulation Card

When handling emulation cards, take the following precautions:

- Always store emulation cards in their electrostatic-proof cases. Static electricity and magnets can alter the information stored on emulation cards.
- Do not touch the emulation card's gold connectors. Dirt, dust, oil, or perspiration may damage the card.

To install an emulation card, follow these steps.

1. Turn off the printer.

2. Remove the emulation card from its case, being careful not to touch the gold connectors.
3. Turn the emulation card so the label faces *up* . Insert the emulation card into the card slot on the front left side of the printer.

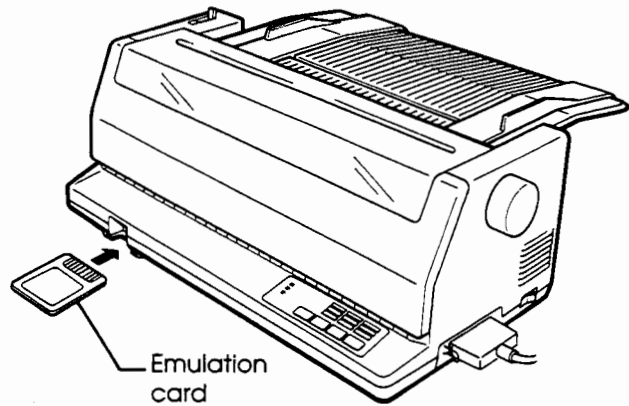

Inserting the emulation card

4. Enter setup mode and select the emulation in MENU 1 and/or MENU 2. See Chapter 5 for details.
5. If the emulation does not appear in the setup menu, the card was probably not inserted correctly. Remove the card and try inserting it again.

Removing an Emulation Card

To remove an emulation card, turn off the printer. Pull the emulation card out of the card slot.

Return the emulation card to its electrostatic-proof case. Be careful not to drop or bend the card.

CHANGING THE INTERFACE BOARD

Your printer is shipped with a Centronics parallel interface board. To replace the parallel interface board with an optional RS-232C serial interface board, follow these steps.

1. Turn off and unplug the printer. If a parallel interface cable is connected to the printer, disconnect it.
2. Beneath the parallel interface connector, locate the two screws shown in the following figure. Using a Phillips #1 screwdriver, carefully remove both screws. A flat washer and a spring washer accompany each screw.

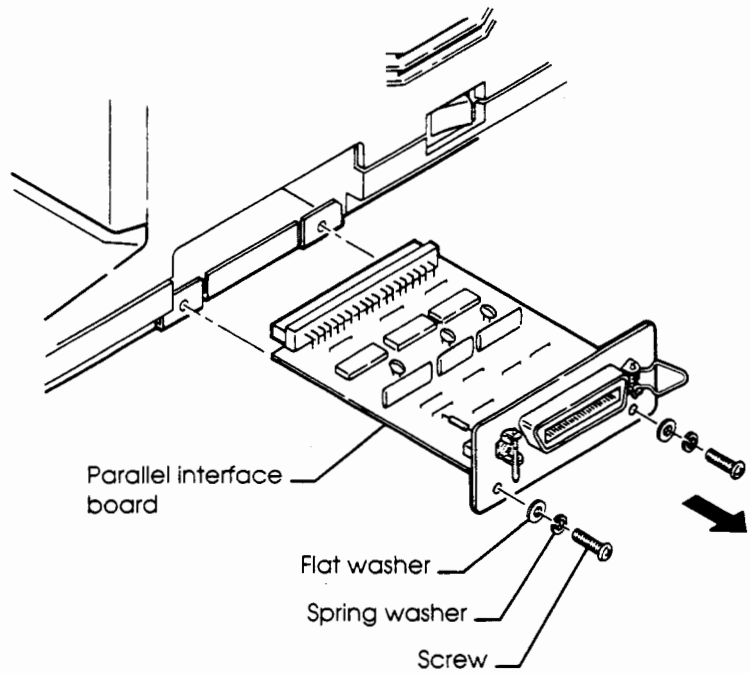

Removing the interface board

3. Pull the parallel interface board out of the printer.

NOTE

You may need to give the board a strong tug to disconnect it from the printer.

4. Remove the serial interface board from its package. Hold the interface board by the metal end, being careful not to touch the card surface. Slide the board into the slot from which the parallel interface board was removed. The board can only be inserted one way. Push the board all the way into the printer.
5. Reinstall the two screws and washers removed in step 2.
6. Plug in the printer and turn on the power. To connect the serial interface, follow the procedures in Chapter 2, starting with the section entitled **Connecting the Printer to Your Computer**.

Color Kits

A monochrome printer can be reconfigured as a color printer. To do so, ask your dealer to install a color kit.

CONSUMABLES, OPTIONS, AND PUBLICATIONS



This appendix lists the consumables, options, and programmer's manuals available for the printer. Contact your dealer for information on ordering any of these items.

CONSUMABLES

Consumables	Order Numbers
Ribbon cartridges	
Black ribbon	D30L-9001-0939
Color ribbon	D30L-9001-0938
Print head	D86B-1171-C203

OPTIONS

Options	Order Numbers	Description
Cut sheet feeder	ASF300-FJ1101	Single bin feeder
	ASF300-FJ1111	Double bin adapter; mounted on single bin feeder
	FJ1121	Envelope adapter
Font cards	D05B-2610-C810	Dutch 801 PS, Script 12, Old English 10, Humanist 521 PS
	D05B-2610-C811	Swiss 721 PS, Script 12, Old English 10, Humanist 521
	D05B-2610-C812	Courier 10/12/15/17, Light Italic 12, Orator 10
	D05B-2610-C813	Prestige 10/12/15/17, Light Italic 12, Letter Gothic 12
	D05B-2610-C814	OCR-A, OCR-B, Scientific 12/18

**OPTIONS
(CONTINUED)**

Options	Order Numbers	Description
Emulation cards	D05B-2610-C611	Fujitsu DPL24D (Diablo 630) emulation
	D05B-2610-C612	DEC LA50/75/120/210 emulation
Color kit	D05B-9010-C111	Dealer-installable option; includes a color ribbon.
Serial interface board	D05B-9010-C121	RS-232C serial interface board

PUBLICATIONS

Publications	Order Numbers
Programmer's Manual (IBM XL24 Emulation)	B-69519
Programmer's Manual (Epson LQ2500/2550 Emulation)	B-69520
Programmer's Manual (Fujitsu DPL24D Emulation); compatible with Diablo 630 API	B-69593
Programmer's Manual (DEC LA50/75/120/210 Emulation)	B-69637



PRINTER AND PAPER SPECIFICATIONS

This appendix lists physical, functional, and performance specifications for the printer. It also gives detailed specifications for paper.

PHYSICAL SPECIFICATIONS

Dimensions	Height: 188 mm (7.4 inches) Width: 460 mm (18.1 inches) Depth: 250 mm (9.8 inches)
Weight	6.0 kg (13.2 lbs)
AC power requirements	100 to 120 VAC +10%, 50/60 Hz +2%/-4% 220 to 240 VAC +10%, 50/60 Hz +2%/-4%
Power consumption	114 VA for 120 VAC and 33% duty printing 120 VA for 220 VAC and 33% duty printing
Interface	Centronics parallel or RS-232C serial
Data buffer size	256, 2K, 8K, or 24K bytes
Download buffer	Maximum 31.75K (32K minus data buffer size)
Operating environment	5 to 38°C (41 to 100°F) 30% to 80% RH (no condensation) Wet bulb temperature, less than 29°C (84°F)
Storage environment	-25 to 60°C (-13 to 140°F) 10% to 90% RH (no condensation)

FUNCTIONAL SPECIFICATIONS

Print method	Impact dot matrix with a 0.2 mm, 24-wire head
Print direction	Bidirectional, unidirectional, or logic seeking

Specifications

Character cell	Horizontal x vertical	
Letter (10 cpi)	36 x 24 dots	
Letter (12 cpi)	30 x 24 dots	
Correspondence	18 x 24 dots	
Draft	12 x 24 dots	
High-speed draft	9 x 24 dots	
Paper handling	Standard friction-feed platen (single sheet) Standard rear push tractors (continuous forms) Optional cut sheet feeder (see Chapter 8)	
Paper type	1- to 4-part side-glued or paper-stapled fan-folded continuous forms or label sheets with sprocket holes 1- to 4-part top-glued single sheets and envelopes	
Paper size	Continuous forms	Single sheets
Width	102-330 mm (4-13 inches)	101-330 mm (4-13 inches)
Length	102 mm (4 inches) or greater	76-364 mm (3-14.3 inches)
Paper thickness	Up to 0.3 mm (0.012 inch) (For envelopes, the maximum thickness at the multi-layer part can be up to 0.5 mm (0.02 inch)).	
Page length	Depends upon emulation. The default is 11 inches for all emulations. DPL24C PLUS and IBM XL24: 3, 3.5, 4, 5, 5.5, 6, 7, 8, 8.5, 11, 11.6, 12, 14, or 18 inches Epson LQ-2500/-2550: 4, 4.5, 5, 5.5, ..., 11, 11.5, 12, ..., 22 inches	
Number of copies	Up to 4, including the original	
Command sets (emulations)		
Resident	Fujitsu DPL24C PLUS IBM Proprinter XL24 Epson LQ-2500/-2550	
Emulation cards	Fujitsu DPL24D (Diablo 630 API) DEC LA50/75/120/210	

Character set	IBM PC character sets 1 and 2 IBM PS/2 character sets (code pages 437, 850, 860, 863, and 865) ISO 8859-1/ECMA 94 International character sets
Standard fonts	
Resident	Letter quality fonts: Courier 10, Prestige Elite 12, Boldface PS, and Pica 10. Correspondence, Draft, High-speed Draft, and Compressed also available.
Optional	Available on font cards. See Appendix A.
Download	Available from independent vendors
Character pitch	2.5, 3, 5, 6, 10, 12, 15, 17.1, 18, or 20 cpi, or proportional spacing. Programmable in 1/360 inch or various increments for image graphics.
Characters per line	110 cpl at 10 cpi 132 cpl at 12 cpi 165 cpl at 15 cpi 188 cpl at 17.1 cpi 198 cpl at 18 cpi 220 cpl at 20 cpi
Line spacing	1, 2, 3, 4, 5, 6, 7, or 8 lines per inch. Programmable in 1/120 or 1/180 inch. increments for image graphics.

PERFORMANCE SPECIFICATIONS

Print speed	10 cpi	12 cpi
Letter	50 cps	60 cps
Correspondence	100 cps	120 cps
Draft	150 cps	180 cps
High-speed draft	200 cps	240 cps
	cpi: characters per inch	
	cps: characters per second	

Line feed speed 110 ms per line at 6 lines per inch

Specifications

PRINTER AND PAPER SPECIFICATIONS

Form feed speed	2 inches per second
Ribbon life	Color: Up to 0.2 million characters per color Black: Up to 2 million characters
Certification	
Safety	UL 478-05 CSA C22.2/220 for 100 to 120 VAC TUV (DIN IEC 950) FEI for 220 to 240 VAC
Radiation	Class B of FCC Part 15J Canadian Regulations for 100 to 120 VAC Class B of VDE 0871 for 220 to 240 VAC

PAPER SPECIFICATIONS

Print Area

This section illustrates the recommended print area for single sheets and continuous forms.

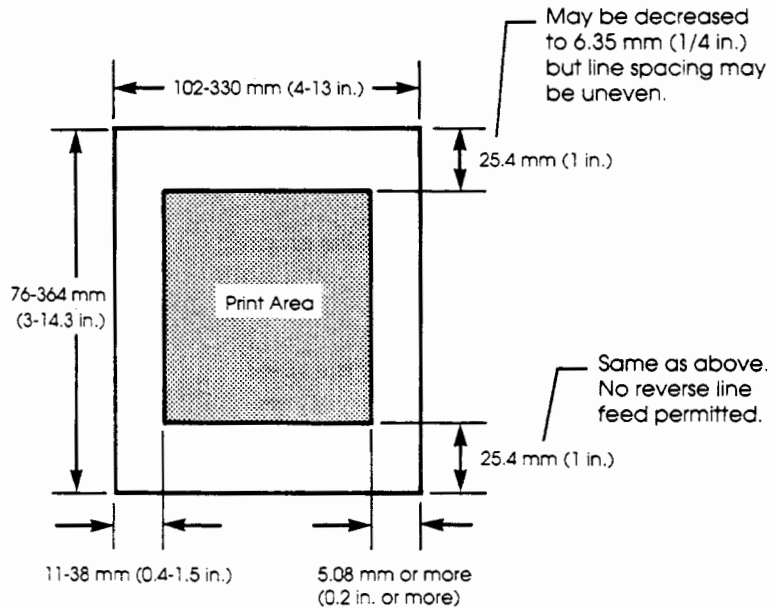

Print area for single sheets

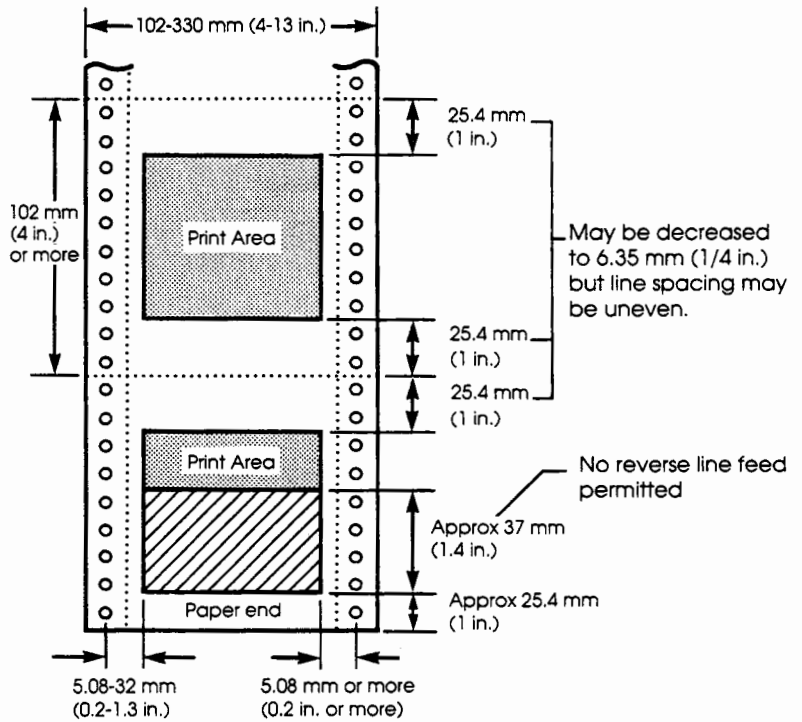

- Perforation
- Uneven line spacing area



Print area for continuous forms

Paper Thickness

Paper thickness is indicated by the weight of the paper, in grams per square meter (g/m²) or in pounds per bond (lbs/bond). The following table illustrates the allowable paper thickness for one-part paper or for each sheet of multi-part paper. The total thickness must not exceed 0.3 mm (0.012 inch).

For carbonless or carbon-backed paper, the weight may vary depending upon the paper manufacturer. When using paper of borderline thickness, testing the paper is recommended.

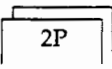
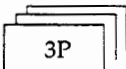
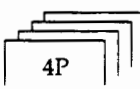
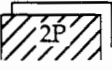
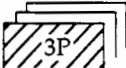
Specifications

Type of Paper	Part	Thickness
One-part	Single	52-81 g/m ² (45-70 kg or 14-22 lb)
Carbonless   	Top	50-64 g/m ² (43-55 kg or 13-17 lb)
	Bottom	50-81 g/m ² (43-70 kg or 13-22 lb)
	Top	40-50 g/m ² (34-43 kg or 11-13 lb)
	Middle	40-50 g/m ² (34-43 kg or 11-13 lb)
	Bottom	40-64 g/m ² (34-55 kg or 11-17 lb)
	Top Middle Middle Bottom	40 g/m ² (34 kg or 11 lb) for each part
Carbon-backed   	Top	52-64 g/m ² (45-55 kg or 14-17 lb)
	Bottom	52-81 g/m ² (45-70 kg or 14-22 lb)
	Top	40-52 g/m ² (34-45 kg or 11-14 lb)
	Middle	40-52 g/m ² (34-45 kg or 11-14 lb)
	Bottom	40-64 g/m ² (34-55 kg or 11-17 lb)
	Top Middle Middle Bottom	40 g/m ² (34 kg or 11 lb) for each part
Carbon-interleaved	Top Carbon Bottom	35-52 g/m ² (30-45 kg or 9-14 lb) Counted as one sheet 35-64 g/m ² (30-55 kg or 9-17 lb) Avoid using carbon-interleaved single sheets.

kg: Kilogram weight of 1000 sheets of 788 x 1091 mm paper (1.16 g/m²)

lb: Pound weight of 500 sheets of 17 x 22 inch paper (3.76 g/m²)

COMMAND SETS



This printer has four resident comand sets. The native command set, Fujitsu DPL24C PLUS for DL-series printers, is detailed in the second part of this manual.

This appendix lists the comands in the remaining three resident comand sets: IBM Proprinter XL24, Epson LQ-2500, and Epson LQ-2550. Separate programmer's manuals for these emulations are also available. See Appendix A for order numbers.

**IBM PROPRINTER XL24
EMULATION**

This section lists the printer commands for the IBM Proprinter XL24 emulation. Asterisks in the "Function" column indicate extended commands not supported by the original printer. See the *Programmer's Manual (IBM XL24 Emulation)* for detailed information on using these commands.

Function			Command
Print Mode Control			
Double-strike (bold) printing on			ESC G
Double-strike (bold) printing off			ESC H
Emphasized (shadow) printing on			ESC E
Emphasized (shadow) printing off			ESC F
One-line double width characters on			SO or ESC SO
One-line double width characters off			DC4
Double width characters on/off (on: $n = 1$, off: $n = 0$)			ESC W (n)
Double height/double width characters $n_1 = 4, n_2 = 0, m_1 = 0, m_2 = 0$ m_3 controls character height and line spacing:			ESC [@ (n_1) (n_2) (m_1) ... (m_4)
m_3	Height	Spacing	
0	Unchanged	Unchanged	
1	Normal	Unchanged	
2	Double	Unchanged	
16	Unchanged	Single	
17	Normal	Single	
18	Double	Single	
32	Unchanged	Double	
33	Normal	Double	
34	Double	Double	
m_4 controls character width.			
m_4	Width		
0	Unchanged		
1	Normal		
2	Double		

Function	Command
Condensed characters on Condensed and elite characters off Subscript or superscript printing on (subscript: $n = 1$, superscript: $n = 0$) Subscript and superscript printing off Underline on/off (on: $n = 1$, off: $n = 0$) Overline on/off (on: $n = 1$, off: $n = 0$)	SI or ESC SI DC2 ESC S (n) ESC T ESC- (n) ESC _ (n)
Horizontal Control Space Backspace Carriage return Elite characters on Proportionally spaced characters on/off (on: $n = 1$, off: $n = 0$)	SP BS CR ESC : ESC P (n)
Vertical Control Line feed Form feed Advance paper $n/216$ inch ($0 \leq n \leq 255$) Advance paper $n/180$ inch (in AG mode) ($0 \leq n \leq 255$) Set line spacing to $1/8$ lines Set line spacing to $7/72$ inch Set line spacing to $n/216$ inch ($0 \leq n \leq 255$) Set line spacing to $n/180$ inch (in AG mode) ($0 \leq n \leq 255$) Preset line spacing to $n/72$ inch ($0 \leq n \leq 255$) Preset line spacing to $n/60$ inch (in AG mode) ($0 \leq n \leq 255$) Set line spacing to the preset value The preset line spacing command is ESC A (n).	LF FF ESC J (n) ESC J (n) ESC 0 ESC 1 ESC 3 (n) ESC 3 (n) ESC A (n) ESC A (n) ESC 2

Function	Command
<p>Change graphics line spacing base to 1/216 or 1/180 inch (for ESC J and ESC 3)</p> <p>$m_1 = 4, m_2 = 0$</p> <p>$t_1 = \text{any value}, t_2 = \text{any value}, t_3 = 0$</p> <p>$t_4 = 180 \text{ or } 216$</p>	<p>ESC [\ (m_1) (m_2) (t_1) ... (t_4)</p>
<p>Tabulation</p> <p>Horizontal tab execution</p> <p>Set horizontal tabs</p> <p>The values of n_1 to n_k in this command are the ASCII values of the print columns (at the current character width) where you wish to set tabs. ($1 \leq n \leq 255$) ($1 \leq k \leq 28$)</p> <p>Clear all horizontal tabs</p> <p>Move print position right by $n/120$ inch ($0 \leq n_1, n_2 \leq 255$) ($n = n_1 + n_2 \times 256$)</p> <p>Vertical tab execution</p> <p>Set vertical tabs</p> <p>The values of n_1 to n_k in this command are the ASCII values of the lines (at the current line spacing) where you wish to set tabs. ($1 \leq n \leq 255$) ($1 \leq k \leq 64$)</p> <p>Clear all vertical tabs</p> <p>Reset tabs to default values</p>	<p>HT</p> <p>ESC D (n_1) ... (n_k) NUL</p> <p>ESC D NUL</p> <p>ESC d (n_1) (n_2)</p> <p>VT</p> <p>ESC B (n_1) ... (n_k) NUL</p> <p>ESC B NUL</p> <p>ESC R</p>
<p>Page Formatting</p> <p>Set left margin at column n and right margin at column m ($0 \leq n, m \leq 255$)</p> <p>Set perforation skip by n lines ($0 \leq n \leq 255$)</p> <p>Perforation skip off</p> <p>Set page length to n lines ($1 \leq n \leq 255$)</p> <p>Set page length to n inches ($1 \leq n \leq 22$)</p> <p>Set top of form</p>	<p>ESC X (n) (m)</p> <p>ESC N (n)</p> <p>ESC O</p> <p>ESC C (n)</p> <p>ESC C NUL (n)</p> <p>ESC 4</p>

Function	Command
<p>Color Selection*</p> <p>Select printing color*</p> <p>$n = 0$: Black</p> <p>1: Magenta (red)</p> <p>2: Cyan (blue)</p> <p>3: Violet</p> <p>4: Yellow</p> <p>5: Orange</p> <p>6: Green</p>	<p>ESC r (n)</p>
<p>Character Set Control</p> <p>Select character set 1</p> <p>Select character set 2</p> <p>Print $n_1 + n_2 \times 256$ characters from all-character set</p> <p>(<i>chars.</i>: characters to be printed)</p> <p>Print a character from all-character set</p> <p>(<i>char.</i>: a character to be printed)</p> <p>Clear input buffer</p> <p>Select printer</p> <p>Deselect printer (ignore input)</p>	<p>ESC 7</p> <p>ESC 6</p> <p>ESC \ (n_1) (n_2) (<i>chars.</i>)</p> <p>ESC ^ (<i>char.</i>)</p> <p>CAN</p> <p>DC1</p> <p>ESC Q #</p>
<p>Downloading</p> <p>Select resident or download font</p> <p>$n = 0$: Resident Draft</p> <p>2: Resident Courier</p> <p>4: Download Draft</p> <p>6: Download Courier</p> <p>Create download font</p>	<p>ESC I (n)</p> <p>ESC = (n_1) (n_2) ID (m_1) (m_2) (<i>data</i>)</p>

Command Sets

Function	Command
Bit Image Graphics	
Single density graphics	ESC K (n ₁)(n ₂) (data)
Double density graphics	ESC L (n ₁)(n ₂) (data)
High speed double density graphics	ESC Y (n ₁)(n ₂) (data)
Quadruple density graphics	ESC Z (n ₁)(n ₂) (data)
High-resolution graphics	ESC [g (n ₁)(n ₂) (m) (data)
Select graphics mode (in AG mode only)	ESC * (m) (c ₁) (c ₂) (data)
Cut Sheet Feeder Control*	
Feed a sheet from bin 1*	ESC EM 1
Feed a sheet from bin 2*	ESC EM 2
Feed a sheet from bin 3*	ESC EM E
Eject a page from the printer*	ESC EM R
Select bin 1 for following pages*	//1//
Select bin 2 for following pages*	//2//
Select bin 3 for following pages*	//E//
Eject sheet at end of current page*	//R//
Change bins at next page*	//C//
Printer Option Control*	
HCPP control*	//F//
HCPP control*	//T//
Miscellaneous	
Sound the bell	BEL
Unidirectional printing on/off (on: n = 1, off: n = 0)	ESC U (n)
Add a carriage return to all line feeds (on: n = 1, off: n = 0)	ESC 5 (n)
Printer offline	ESC j
Enter to online setup mode	ESC e O N L I N E

**EPSON LQ-2500/
LQ-2550 EMULATIONS**

This section lists the printer commands for the Epson LQ-2500 and LQ-2550 emulations. Asterisks in the "Function" column indicate extended commands not supported by the original printer. See the *Programmer's Manual (Epson LQ2500/2550 Emulation)* for detailed information on using these commands.

Function	Command
Print Mode Control	
Double-strike (bold) printing on	ESC G
Double-strike (bold) printing off	ESC H
Emphasized (shadow) printing on	ESC E
Emphasized (shadow) printing off	ESC F
Italic printing on	ESC 4
Italic printing off	ESC 5
Select character style*	ESC q (n)
n = 0: Normal	
1: Outlined	
2: Shaded	
3: Outlined and shadowed	
One-line double width characters on	SO or ESC SO
One-line double width characters off	DC4
Double width characters on/off	ESC W (n)
(on: n = 1, off: n = 0)	
Double height characters on/off*	ESC w (n)
(on: n = 1, off: n = 0)	
Condensed characters on	SI or ESC SI
Condensed characters off	DC2
Subscript or superscript printing on	ESC S (n)
(subscript: n = 1, superscript: n = 0)	
Subscript and superscript printing off	ESC T
Underline on/off*	ESC - (n)
(on: n = 1, off: n = 0)	

Function	Command
<p>Select printing style</p> <p>This command allows you to combine various printing styles. The value of n is the sum of the values of the styles you want to combine.</p> <p>$n = 0$: Pica pitch 1: Elite pitch 2: Proportional spacing 4: Condensed 8: Shadow 16: Bold 32: Double width 64: Italics 128: Underline</p>	<p>ESC ! (n)</p>
<p>Horizontal Control</p> <p>Space Backspace Carriage return Set elite pitch Set pica pitch Set 15 CPI* Proportionally spaced characters on/off (on: $n = 1$, off: $n = 0$) Set inter-character space to $n/120$ inch (for draft) or $n/180$ inch (for letter) ($0 \leq n \leq 127$)</p>	<p>SP BS CR ESC M ESC P ESC g ESC p (n) ESC SP (n)</p>
<p>Vertical Control</p> <p>Line feed Form feed Advance paper $n/180$ inch ($0 \leq n \leq 255$) Reverse paper $n/180$ inch ($0 \leq n \leq 255$)* Set line spacing to $1/8$ inch Set line spacing to $n/180$ inch ($0 \leq n \leq 255$) Set line spacing to $n/60$ inch ($0 \leq n \leq 127$) Set line spacing to $1/6$ inch Set line spacing to $n/360$ inch ($0 \leq n \leq 255$)</p>	<p>LF FF ESC J (n) ESC j (n) ESC 0 ESC 3 (n) ESC A (n) ESC 2 ESC + (n)</p>

Function	Command
Tabulation	
Horizontal tab execution	HT
Set horizontal tabs The values of n_1 to n_k in this command are the ASCII values of the print columns (at the current character width) where you wish to set tabs. ($1 \leq n \leq 255$) ($1 \leq k \leq 32$)	ESC D (n_1) ... (n_k) NUL
Move print position $n/60$ inch right from left margin ($n = n_1 + n_2 \times 256$)	ESC \$ (n_1) (n_2)
Move print position $n/120$ inch (for draft) or $n/180$ inch (for letter) left or right from the current position ($n = n_1 + n_2 \times 256$)	ESC \ (n_1) (n_2)
Vertical tab execution	VT
Set vertical tabs The values of n_1 to n_k in this command are the ASCII values of the lines (at the current line spacing) where you wish to set tabs. ($1 \leq n \leq 255$) ($1 \leq k \leq 16$)	ESC B (n_1) ... (n_k) NUL
Select vertical tabs by channel The values of n_1 to n_k in this command are the ASCII values of the lines (at the current line spacing) where you wish to set tabs. ($0 \leq c \leq 7$) ($1 \leq n \leq 255$) ($1 \leq k \leq 16$)	ESC b (c) (n_1)...(n_k) NUL
Select vertical tab channel ($0 \leq c \leq 7$)	ESC / (c)
Page Formatting	
Set right margin to column n ($1 \leq n \leq 255$)	ESC Q (n)
Set left margin to column $n + 1$ ($1 \leq n \leq 255$)	ESC 1 (n)
Set perforation skip by n lines ($1 \leq n \leq 127$)	ESC N (n)

Function	Command
Perforation skip off Set page length to n lines ($1 \leq n \leq 127$)* Set page length to n inches ($1 \leq n \leq 22$)*	ESC O ESC C (n) ESC C NUL (n)
Color Selection Select printing color n = 0: Black 1: Magenta (red) 2: Cyan (blue) 3: Violet 4: Yellow 5: Orange 6: Green	ESC r (n)
Character Set Control Select character set 2 Select character set 1 Select character set table n = 0: Italics character set 1: Graphics character set 2: Download character set (LQ-2550 only) Select international character set n = 0: USA 1: France 2: Germany 3: United Kingdom 4: Denmark 1 5: Sweden 6: Italy 7: Spanish 1 8: Japan 9: Norway 10: Denmark 2 11: Spanish 2 12: Latin America	ESC 7 ESC 6 ESC t (n) ESC R (n)

Function	Command
Clear input buffer Select printer Deselect printer (ignore input)* Delete a character Force most significant bit to 1 Force most significant bit to 0 Cancel control over most significant bit*	CAN DC1 DC3 DEL ESC > ESC = ESC #
Word Processing Line justification on* <i>n</i> = 0: Left justify 1: Center 2: Right justify 3: Full justify	ESC a (<i>n</i>)
Font Selection and Downloading Select font Select letter or draft quality <i>n</i> = 0: Draft 1: Letter Select type style* <i>n</i> = 0: Dutch 801 (*) 1: Swiss 721 (*) 2: Courier (default) 3: Prestige 4: Script (*) 5: OCR-B (*) 6: OCR-A (*) *with a font card Copy resident font to download area* Create download font*	ESC % (<i>n</i>) ESC x (<i>n</i>) ESC k (<i>n</i>) ESC : (<i>n</i> ₁) (<i>n</i> ₂) (<i>n</i> ₃) ESC & NUL (<i>n</i> ₁) (<i>n</i> ₂) (<i>d</i> ₀) (<i>d</i> ₁) (<i>d</i> ₂) (<i>data</i>)

Command Sets

Function	Command
Bit Image Graphics	
Graphics type m graphics	ESC * (m) (n ₁) (n ₂) (data)
Bit image mode definition	ESC ? (s) (n)
Single density graphics	ESC K (n ₁) (n ₂) (data)
Double density graphics	ESC L (n ₁) (n ₂) (data)
High-speed double density graphics	ESC Y (n ₁) (n ₂) (data)
Quadruple density graphics	ESC Z (n ₁) (n ₂) (data)
Cut Sheet Feeder Control	
Feed a sheet from bin 1	ESC EM 1
Feed a sheet from bin 2	ESC EM 2
Feed a sheet from bin 3*	ESC EM E
ASF mode on	ESC EM 4
ASF mode off	ESC EM 0
Eject a page from the printer	ESC EM R
Select bin 1 for following pages*	//1//
Select bin 2 for following pages*	//2//
Select bin 3 for following pages*	//E//
Eject sheet at end of current page*	//R//
Change bins at next page*	//C//
Printer Option Control*	
HCPP Control*	//F//
HCPP control*	//T//
Miscellaneous	
Sound the bell	BEL
Move print head to home position	ESC <
Unidirectional printing on/off (on: n = 1, off: n = 0)	ESC U (n)
Initialize printer*	ESC @
Half speed printing on/off (on: n = 1, off: n = 0)	ESC s (n)
Enter to online setup mode	ESC e O N L I N E

INTERFACE INFORMATION

This printer can communicate with a computer through either a Centronics parallel or an RS-232C serial interface. The printer cannot be equipped with both interfaces at the same time.

If necessary, you can remove the interface currently used and install the other interface (see Chapter 8 for details).

This appendix provides information you may need if you are wiring your own interface cables or programming for computer-to-printer communications. Most users will not need to refer to this appendix. If you are simply trying to connect your printer to your computer, check the instructions in Chapter 2.

PARALLEL INTERFACE

The Centronics interface is the industry-standard parallel interface. The cable connector at the printer side should be a shielded Amphenol DDK 57FE-30360 or its equivalent.

The connector pin assignments are shown in the following table. In this table:

- "Input" indicates a signal input to the printer from the computer.
- "Output" indicates a signal output from the printer.
- The return lines specified in the second column represent twisted pairs, with one side connected to signal ground.
- The standard signal levels are 0.0 to +0.4 V for low, and +2.4 to +5.0 V for high.

Pin No.	Return Pin No.	Signal Name	Direction	Description
1	19	<u>Data Strobe</u>	Input	Strobe pulse for reading data. The printer reads data when this signal is low. The pulse width must be 1 μ s or more at the receiving terminal.
2-9	20-27	Data 1 to 8	Input	Data 8 (pin 9) is the most significant bit, but is not used in 7-bit ASCII communications. All signals which indicate data is logical 1 should go high at least 1 μ s before the falling edge of the Data Strobe signal and must stay high for at least 1 μ s after the rising edge.
10	28	<u>Acknowledge</u>	Output	Pulse signal indicating the printer has received data and is ready to accept the next data. This signal is also issued when the printer is switched from offline to online.
11	29	Busy	Output	Output data cannot be received when this signal is high. This signal goes high during data entry, when the printer is offline, when the buffer is full, or when an error occurs.
12	30	Paper Empty	Output	This signal goes high when the printer is out of paper.
13	-	Select	Output	This signal indicates the selected (online) state when high and the deselected (offline) state when low.

Pin No.	Return Pin No.	Signal Name	Direction	Description
14	-	$\overline{\text{Auto Feed XT}}$	Input	Not used
15	-	-	-	No connection
16	-	Signal Ground	-	Logic ground level (0 V)
17	-	Frame Ground	-	Printer chassis ground line. FG and SG are connected.
18	-	-	-	No connection
19-30	-	Signal Ground	-	Twisted pair return lines
31	-	$\overline{\text{Input Prime}}$	Input	If this signal is low for more than 50 μs , the printer is reset to the initial condition and is placed online.
32	-	$\overline{\text{Fault}}$	Output	This signal goes low when the printer is offline, paper is out, or when there is printer error.
33	-	Signal Ground	-	Logic ground level (0 V)
34	-	-	-	No connection
35	-	+5 VR	Output	Pulled up to +5 V through a 3.3 k Ω resistor.
36	-	$\overline{\text{SLCT-IN}}$	Input	Not used

Data Transmission Timing

The Centronics interface of this printer guarantees the received data when the Data and Data Strobe signals from the computer have the following timing with respect to the Busy and Acknowledge signals from the printer.

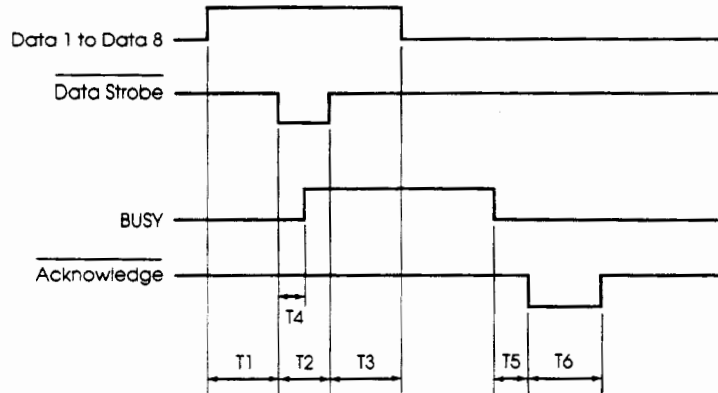

$T1, T2, T3 > 1 \mu s$
 $T4 < 1 \mu s$
 $0 \mu s < T5 < 3 \mu s$
 $2 \mu s < T6 < 6 \mu s$

SERIAL INTERFACE

The RS-232C interface is the standard interface for data terminal equipment. The cable connector at the printer side should be a D-subminiature Cannon or Cinch DB-25P male connector or equivalent conforming to EIA standards.

The following table shows the pin assignments that are commonly used by most computers. In this table:

- "Input" indicates a signal input to the printer from the computer.
- "Output" indicates a signal output from the printer.
- The signal level for mark (logical 1) is -3 V or lower; for space (logical 0), it is +3 V or higher.

Pin No.	Signal Name	Direction	Description
1	FG	-	Frame Ground
2	TD	Output	Transmitted Data. This pin carries information from the printer to the computer.
3	RD	Input	Received Data. This pin carries information from the computer to the printer.
4	RTS	Output	Request To Send. Spaces are sent when the printer is ready to transmit data.
5	CTS	Input	Clear To Send. Spaces are sent when the computer is ready to receive data.
6	DSR	Input	Data Set Ready. Spaces are sent when the computer has been powered on and is ready.
7	SG	-	Signal Ground (common return)
8	CD	Input	Data Carrier Detect. Spaces are sent when the computer lets the printer receive data.
11	RC	Output	Reverse Channel. This is used in the RC protocol only. Spaces are sent when the printer is ready to send or receive data.
20	DTR	Output	Data Terminal Ready. Spaces are sent when the printer has been powered on and is ready.

Interface

Serial Options

The serial options listed below must be set the same way on both the computer and the printer. Using the printer's control panel, the computer's operating system, or your software, you can change the options specified as "selectable."

Transmission mode:	Asynchronous, full duplex or half duplex (selectable)
Speeds:	150, 300, 600, 1200, 2400, 4800, 9600, or 19200 baud (selectable)
Data bits:	7 or 8 bits (selectable)
Parity bit:	Odd, even, mark, space, or none (selectable)
Start bit:	1 bit
Stop bit:	1 or 2 bits (selectable)
Protocol:	XON/XOFF (DC1/DC3), DTR (Data Terminal Ready), RC (Reverse Channel), or ETX/ACK (selectable)
Buffer size:	256, 2K, 8K, or 24K bytes (selectable)

Cable Wiring

This printer allows two types of serial communication control: DSR enabled and DSR disabled. The type you use is determined by your computer's requirements and will affect the way the interface cable is wired. To select between DSR enabled and DSR disabled control, use the printer's **HARDWRE** (hardware) function (see Chapter 5).

DSR disabled control offers simpler cabling and communication than DSR enabled control. It can be used for interfacing with an IBM PC or most other personal computers. With DSR disabled control, input control signals DSR, CTS, and CD are always considered high, regardless of their actual states. Therefore, a wire connection for these pins is not required. The following figure shows the wiring required for connection to an IBM PC.

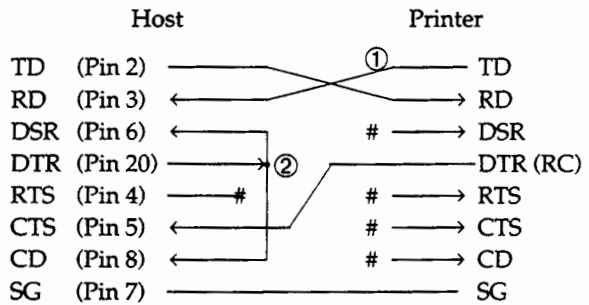

indicates an open wire.

Wire ① is unnecessary for the DTR (or RC) protocol.

Some computers may not require wire ②.

DSR enabled control enables communication with an RS-232C interface. The CTS and DSR input control signals are enabled; CD is ignored. DSR must be high when the printer receives data. If the printer has data to be transmitted to the computer, the printer transmits the data immediately when both DSR and CTS are high.

For connection to a DCE (data communications equipment) device using DSR enabled control, use a straight-through cable. For connection to a DTE (data terminal equipment) device, use a null-modem cable as shown below.

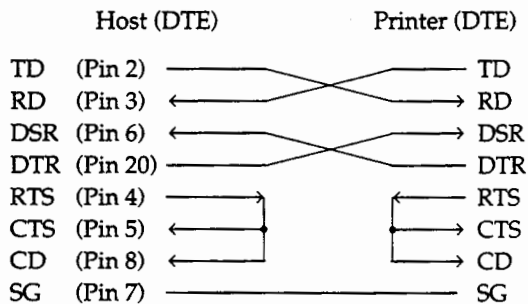

Serial Protocols

A protocol is a set of instructions controlling the way data is transmitted between devices such as a computer and printer. The protocol ensures that the computer does not send information to the printer faster than it can be processed. By telling the computer when it can receive data, the protocol prevents the printer's buffer from overflowing.

This printer offers a choice of four different protocols for connection to a variety of computers: XON/XOFF, DTR, RC, and ETX/ACK. The following table describes each protocol. If your computer's documentation does not recommend a protocol to use, try DTR.

Protocol	Description
XON/XOFF (DC1/DC3)	When the printer is ready to receive data, it sends the XON (DC1) code (hex 11). When fewer than 255 bytes of space remain in the buffer (or when the printer is switched offline), the printer sends the XOFF (DC3) code (hex 13). (When the input buffer is configured for 256 bytes, the buffer limit is reduced from 255 bytes to 63 bytes.) The computer must stop transmitting data within 255 (63) characters of receiving the XOFF, or information may be lost. If paper runs out, the printer sends a NAK code (hex 15).
DTR	This is a hardware protocol; that is, the DTR signal on interface cable pin 20 is used to control the flow of data rather than sending a character code. When the printer is ready to receive data, pin 20 is high. When fewer than 255 (63) bytes of space remain in the buffer (or when the printer is switched offline), pin 20 goes low. The computer must stop transmitting data within 255 (63) characters of DTR going low, or information may be lost.
RC	This protocol is the same as the DTR protocol, except that it uses the Reverse Channel signal (pin 11) instead of the Data Terminal Ready signal (pin 20).
ETX/ACK	<p>This protocol is a little more complicated, but allows faster throughput under some conditions. The computer adds the ETX (End of Text) character (hex 03) at the end of each block of print data. The block, including the ETX character, is usually half the printer's input buffer, but can be as large as the input buffer.</p> <p>When the printer gets the ETX character out of the buffer, it sends an ACK (Acknowledge) character (hex 06) to the computer (the ETX character is not printed). The computer must stop transmitting the next block until receiving the ACK character, or information may be lost. Data transmission continues until the printer finishes printing two blocks, so that high-throughput data communication is provided.</p>

Free Manuals Download Website

<http://myh66.com>

<http://usermanuals.us>

<http://www.somanuals.com>

<http://www.4manuals.cc>

<http://www.manual-lib.com>

<http://www.404manual.com>

<http://www.luxmanual.com>

<http://aubethermostatmanual.com>

Golf course search by state

<http://golfingnear.com>

Email search by domain

<http://emailbydomain.com>

Auto manuals search

<http://auto.somanuals.com>

TV manuals search

<http://tv.somanuals.com>