

FUJITSU DL1150/1250

DOT MATRIX PRINTER

USER'S MANUAL

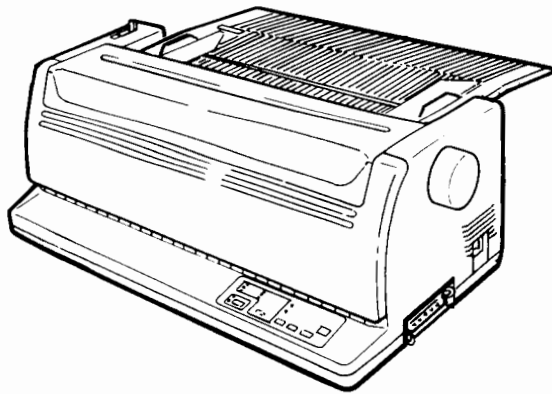

The contents of this manual may be revised without prior notice, and without obligation, to incorporate changes and improvements into units already shipped.

Every effort has been made to ensure that the information included here is complete and accurate at the time of publication, but Fujitsu cannot be held responsible for errors and omissions.

Printer model specifications differ with the print column (110 or 136), power supply (input voltage), and interface (Centronics or RS-232C).

62FH5049E-04 February 1993

Copyright © 1992,1993 FUJITSU LIMITED

Printed in Japan. All rights reserved. No part of this manual may be reproduced or translated, stored in a database or retrieval system, or transmitted, in any form or by any means, electronic, mechanical, photocopying, recording, or otherwise, without the prior written permission of the copyright owner.

TRADEMARK ACKNOWLEDGMENTS

FUJITSU is a registered trademark and Fujitsu Creative Faces is a trademark of Fujitsu Limited. Centronics is a trademark of Centronics Data Computer Coporation. IBM PC and IBM Proprinter XL24 are trademarks of International Business Machines Corporation. LQ-2500 and LQ-2550 are trademarks of Seiko Epson Corporation. Microsoft is a registered trademark and MS-DOS, Windows and Microsoft BASIC are trademarks of Microsoft Corporation. Bitstream is a registered trademark of Bitstream Inc.

Other product names mentioned in this manual may also be trademarks used here for identification only.

This document contains technology relating to strategic products controlled by export control laws of the producing and/or exporting countries. This document or a portion thereof should not be exported (or re-exported) without authorization from the appropriate governmental authorities in accordance with such laws.

FUJITSU LIMITED

ABOUT THIS MANUAL

Thank you for buying this printer. You can expect years of reliable service with very little maintenance. This manual explains how to use your printer to full advantage. It is written for both new and experienced users of printers.

This manual explains how to install, set up, and use your printer and its options. It also explains how to keep the printer in top working condition and what to do should something go wrong. Detailed procedures are provided for first-time users. Experienced users may want to skip some of the details, using the table of contents and chapter introductions to locate needed information.

This manual has several appendixes, a glossary, and an index. Appendix A lists additional documentation available, together with other information, from your dealer or authorized Fujitsu representative. Fujitsu subsidiaries are listed at the end of the manual.

PRINTER MODELS

This manual covers models DL1150, a 110-column printer, and DL1250, a 136-column printer. Each has a 100 V or 200 V power supply, a Centronics or RS-232C interface, and a monochrome or color print feature. All monochrome models can be converted to color by using the color kit option.

Information applies to both models unless otherwise stated. All illustrations show the DL1250.

Model	Print line at 10 cpi	Power supply	Interface	Color
DL1150	— 110 columns	100 V	Centronics	This is available for all models.
			RS-232C	
	200 V	Centronics		
		RS-232C		
DL1250	— 136 columns	100 V	Centronics	
			RS-232C	
	200 V	Centronics		
		RS-232C		

cpi: characters per inch

**Federal Communications Commission
Radio Frequency Interference Statement
for United States Users**

NOTE: This equipment has been tested and found to comply with the limits for a Class B digital device, pursuant to Part 15 of the FCC Rules. These limits are designed to provide reasonable protection against harmful interference in a residential installation. This equipment generates, uses and can radiate radio frequency energy and, if not installed and used in accordance with the instructions, may cause harmful interference to radio communications. However, there is no guarantee that interference will not occur in a particular installation. If this equipment does cause harmful interference to radio or television reception, which can be determined by turning the equipment off and on, the user is encouraged to try to correct the interference by one or more of the following measurements:

- Reorient or relocate the receiving antenna.
- Increase the separation between the equipment and receiver.
- Connect the equipment into an outlet on a circuit different from that to which the receiver is connected.
- Consult the dealer or an experienced radio/TV technician for help.

FCC WARNING: Changes or modifications not expressly approved by the party responsible for compliance could void the user's authority to operate the equipment.

(This equipment has been tested as M3382A or M3383A of the model number.)

NOTES

1. The use of a non-shielded interface cable with the referenced device is prohibited. The length of the parallel interface cable must be 3 meters (10 feet) or less. The length of the serial interface cable must be 15 meters (50 feet) or less.
2. The length of the power cord must be 3 meters (10 feet) or less.

Notice to Canadian Users

This digital apparatus does not exceed the class B limits for radio noise emissions from digital apparatus set out in the Radio Interference Regulations of the Canadian Department of Communications.

Le présent appareil numérique n'émet pas de bruits radioélectriques dépassant les limites applicables aux appareils numériques de la classe B prescrites dans le Règlement sur le brouillage radioélectrique édicté par le ministère des Communications du Canada.

Notice to German Users

Bescheinigung des Herstellers/Importeurs

Hiermit wird bescheinigt, daß der/die/das

- M3382B/M3383B

in Übereinstimmung mit den Bestimmungen der

- AmtsblVfg 243/1991

funk-entstört ist.

Der Deutschen Bundespost wurde das Inverkehrbringen dieses Gerätes angezeigt und die Berechtigung zur Überprüfung der Serie auf Einhaltung der Bestimmungen eingeräumt.

ORGANIZATION

This manual is organized as follows:

The **Operation Quick Reference** section summarizes everyday printer operations. After you become familiar with the printer, use this section as a memory aid.

Chapter 1, Introduction, introduces the printer, listing key features as well as options to enhance the printer's capabilities.

Chapter 2, Setting Up, gives step-by-step procedures for setting up the printer for immediate use. It also familiarizes you with the names of the printer's basic parts. If this is your first printer, you should read the entire chapter before attempting to use the printer.

Chapter 3, Loading and Using Paper, explains how to load and use paper with your printer.

Chapter 4, Printing, covers basic printing operations. Everyday use of the printer's control panel, such as for loading paper and selecting print features, is given in detail. After you become more familiar with the printer, use the **Operation Quick Reference** section at the beginning of the manual to refresh your memory as needed.

Chapter 5, Using Setup Mode, describes how to change the printer's optional settings such as print features, hardware options, and top-of-form. Most settings will only affect print features such as the typestyle and page format. Note that certain settings directly affect hardware and software compatibility. Refer to this chapter as indicated in Chapter 2, or as required.

Chapter 6, Maintenance, explains basic maintenance procedures for this printer.

Chapter 7, Problem Solving, covers problem solving techniques. Before contacting your dealer for help, check the list of problems and solutions provided in this chapter.

Chapter 8, Installing Options, describes the options available for the printer and how to install them.

At the end of this manual, you'll find several appendices, a glossary, and an index. Appendix A lists order numbers for the printer's consumables, options, and publications. The other appendices give additional technical information.

CONVENTIONS

Special information, such as warnings, cautions, and notes, are indicated as follows:

WARNING

A WARNING indicates that personal injury may result if you do not follow a procedure correctly.

CAUTION

A CAUTION indicates that damage to the printer may result if you do not follow a procedure correctly.

NOTE

A NOTE provides "how-to" tips or suggestions to help you perform a procedure correctly. NOTES are particularly useful for first-time users.

For Experienced Users:

If you are familiar with this printer or with dot matrix printers in general, this information will help you use the manual effectively.

TABLE OF CONTENTS

OPERATION QUICK REFERENCE	QR-1
CHAPTER 1 INTRODUCTION	
Features.....	1-1
Options.....	1-2
CHAPTER 2 SETTING UP	
Selecting a Good Location	2-1
Unpacking	2-2
Checking Options and Supplies	2-4
Assembling the Printer	2-5
Installing the Cut Sheet Stand	2-5
Installing the Ribbon Cartridge	2-6
Getting Acquainted With Your Printer	2-9
Connecting the Power Cord	2-10
Testing the Printer (Offline)	2-12
Loading Paper for the Self-Test	2-12
Printing the Self-Test	2-13
Connecting the Printer to Your Computer	2-17
Selecting a Parallel Interface Cable	2-17
Selecting a Serial Interface Cable	2-17
Connecting the Interface Cable	2-18
Selecting an Emulation	2-18
Printing a Sample Page (Online).....	2-22
CHAPTER 3 LOADING AND USING PAPER	
Selecting Paper.....	3-1
Overview of Paper Operations	3-2
Adjusting for Paper Thickness	3-4
Using Single Sheets.....	3-5
Loading a Single Sheet of Paper	3-5
Loading Paper in the Cut Sheet Feeder (Option)	3-8
Ejecting Single Sheets	3-11

Using Continuous Forms	3-12
Positioning the Paper Stack	3-12
Installing the Printer Stand	3-12
Loading Continuous Forms	3-13
Unloading Continuous Forms	3-17
Tearing Off Forms	3-17
Feeding Paper	3-19
Switching Paper Types	3-19
Switching to Single Sheets	3-19
Switching to Continuous Forms	3-20
Tips on Handling Paper	3-20
General Tips	3-20
Multipart Forms	3-20
Envelopes	3-21
Labels	3-21

CHAPTER 4 PRINTING

Selecting Print Features	4-1
Using Commercial Software	4-2
Using the Control Panel	4-2
Selecting MENU1 or MENU2	4-3
Changing the menu font to a specific resident font	4-5
Printing	4-6
Start Printing	4-6
Stop Printing	4-6
Resuming from Paper-Out	4-6
Removing Printed Pages	4-8
Removing Single Sheets	4-8
Removing Continuous Forms	4-8
Clearing the Print Buffer	4-8

CHAPTER 5 USING SETUP MODE

How to Use This Chapter	5-1
Entering Setup Mode	5-2
Overview of Setup Mode	5-4
Setup Mode Example	5-6
Points to Remember	5-9

Printing a List of Selected Options	5-10
Deciding Which Options to Change	5-12
Changing MENU1 and MENU2 Options	5-14
Procedure	5-26
Resetting MENU1 and MENU2	5-27
Changing Hardware Options	5-28
Procedure	5-34
Changing Top-of-Form	5-36
Procedure	5-38
Exiting and Saving	5-39
Procedure	5-39
Resetting Defaults	5-40
Resetting Power-On Defaults	5-40
Resetting Factory Defaults	5-41
Resetting Defaults in MENU1 and MENU2	5-41
Using the Diagnostic Functions	5-42
Printing the Self-test	5-42
Procedure	5-43
Printing Hex Dumps	5-44
Procedure	5-44
Checking Vertical Print Alignment	5-46
Procedure	5-47
Setup Mode Reference	5-49
DPL24C PLUS Organization	5-50
Differences for IBM Proprinter XL24 Emulation	5-52
Differences for Epson LQ-2500/LQ-2550 Emulation	5-52
Online Setup	5-53

CHAPTER 6 MAINTENANCE

Cleaning	6-1
Cleaning and Vacuuming the Printer	6-1
Cleaning the Platen and Paper Bail Rollers	6-2
Replacing the Ribbon Cartridge	6-3
Replacing the Print Head	6-7

CHAPTER 7 PROBLEM SOLVING

Problems and Solutions	7-1
Printing Problems	7-1
Paper Handling Problems	7-4
Operational Problems	7-6
Printer Failures	7-7
Diagnostic Functions	7-8
Getting Help	7-8

CHAPTER 8 INSTALLING OPTIONS

Installing a Cut Sheet Feeder	8-1
Installing the Color Kit	8-2

APPENDIX A SUPPLIES, OPTIONS, AND PUBLICATIONS

A-1

APPENDIX B PRINTER AND PAPER SPECIFICATIONS

Physical Specifications	B-1
Functional Specifications	B-2
Performance Specifications	B-4
Paper Specifications	B-5
Print Area	B-5
Paper Thickness	B-6

APPENDIX C COMMAND SETS

Fujitsu DPL24C PLUS Command Set	C-2
Factory Default Settings	C-14
IBM Proprinter XL24 Emulation	C-17
Epson LQ-2500/LQ-2550 Emulations	C-22

APPENDIX D INTERFACE INFORMATION

Parallel Interface	D-1
Data Transmission Timing	D-4

Serial Interface	D-4
Serial Options	D-6
Cable Wiring	D-6
Serial Protocols	D-7

APPENDIX E CHARACTER SETS

Character Sets 1 and 2 (DPL24C PLUS and IBM XL24 Emulation)	E-1
Italic and Graphics Character Sets (LQ-2500/-2550 Emulation)	E-2
National Character Sets (All Emulations)	E-4
National Character Sets (DPL24C PLUS and IBM XL24 Emulation)	E-11
National Character Sets (LQ-2500/-2550 Emulation)	E-12
National Character Sets and Supported Resident Fonts (All Emulations)	E-15

APPENDIX F RESIDENT FONTS	F-1
---------------------------------	-----

GLOSSARY OF TERMS	GL-1
-------------------------	------

INDEX	IN-1
-------------	------



OPERATION QUICK REFERENCE

This section is written for experienced users — those who are familiar with how the printer works, but who may need to refresh their memories occasionally. *Only the printer's normal (non-setup) mode is covered.* For details on setup mode, see Chapter 5.

Normal mode operation includes everyday operations such as handling paper and selecting fonts. The printer comes up in this mode when turned on. Setup mode is entered by pressing the FONT SELECT and MENU SELECT buttons at the same time while the ONLINE indicator is off (not lit).

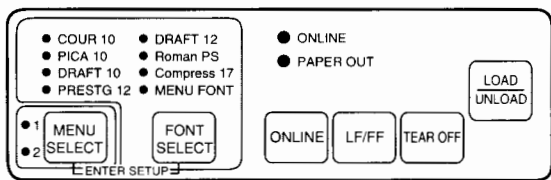

Control panel

The next table lists normal mode operations with required online/offline conditions and what buttons to press.

Printer Operations (Normal Mode)

√ : Operation can be performed when the printer is in this state.
 — : Operation cannot be performed when the printer is in this state.
 N/A: Does not apply.

Operation	Online	Offline	What You Do
Clear print buffer	√	√	Turn printer off. (Press 0 on the power switch.)
Eject single sheets	√	√	Press LF/FF.
Enter normal mode	N/A	N/A	Turn printer on. (Press 1 on the power switch.)
Enter setup mode	—	√	Press MENU SELECT and FONT SELECT.
Exit to normal mode	—	√	Press ONLINE.
Form feed (forward)	√	√	Press and hold LF/FF until the operation starts.
Line feed (forward)	√	√	Press LF/FF within three seconds.
Load paper	√	√	Press LOAD/UNLOAD.
Place printer offline	√	—	Press ONLINE.
Place printer online	—	√	Press ONLINE.
Reset power-on defaults	√	√	Turn printer off, then on.
Select a font (and pitch)	—	√	Press FONT SELECT.
Select MENU1 or MENU2	—	√	Press MENU SELECT.
Start/stop/resume printing	√	—	Start: Send print command. Stop/resume: Press ONLINE.
Self-test printing	√	√	Start: Turn printer off. Press LF/FF while turning printer on. Pause/resume: Press LF/FF or MENU SELECT. Exit: Press ONLINE.
Tear off forms	√	√	Press TEAR OFF. Tear off forms, press any button to retract forms.
Unload paper to park position (forms only)	√	√	Press LOAD/UNLOAD.

INTRODUCTION

Congratulations on purchasing this printer. It is ideal for those who require compactness, versatility, and maximum compatibility with today's software packages and personal computers.

The printer's 24-wire print head provides crisp, clear printing for business, office, and home environments. Your printer is also easy to install and use.

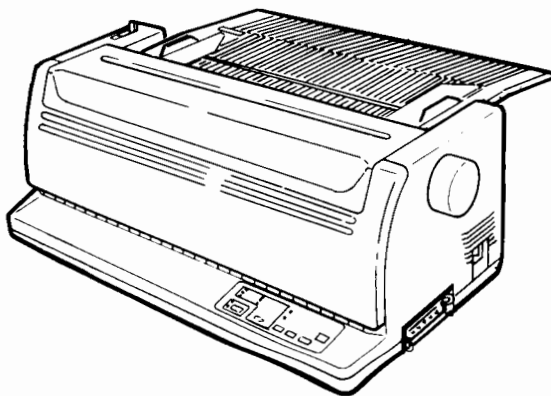

Dot matrix printer

FEATURES

Key printer features and options are listed in the next two sections.

- **Software compatibility.** This printer, which primarily operates with the Fujitsu DPL24C PLUS command set, is compatible with command sets for the IBM Proprinter XL24, Epson LQ-2500, and Epson LQ-2550 printers.
- **Character sets.** IBM PS/2 character sets (code page 437, 850, 852, 855, 860, 863, 865, 866, and DHN), ISO 8859-1/ECMA 94, and so on (total 37 or 39 national character sets; each depends on the emulation) are available. IBM PC character sets 1 and 2 are available for the Fujitsu DPL24C PLUS command set and IBM Proprinter XL24 emulation. Epson Italic character set and graphics character sets 1 and 2 are available for LQ-2500/LQ-2550 emulation.

- **Multiple fonts.** The printer has fifteen resident fonts: Courier 10, Pica 10, OCR-B 10, Prestige Elite 12, Boldface PS, Dutch PS (upright, italic, and bold), Swiss PS (upright, italic, and bold), Correspondence, Compressed, Draft, and High-speed Draft. Up to 31.75K bytes are available for downloading fonts.
- **High-speed printing.** At 10 cpi, print speed ranges from 60 cps for letter quality printing to 200 cps for high-speed draft quality printing.
- **Large print buffer.** The print buffer, 24K bytes maximum, allows you to send files to the printer and return to work in your application.
- **110-column or 136-column print line.** 110-column printers enable printing in landscape mode using letter or A4 size paper. 136-column printers enable printing in landscape mode using legal or standard computer forms.
- **Superior paper handling.** Paper “parking” for continuous forms makes it easy to switch between continuous forms and single sheets. An optional cut sheet feeder enables single sheets to be fed automatically.
- **Color model.** Optional seven-color printing is possible if supported by your software.
- **Maintenance-free.** Periodic cleaning and changing the ribbon cartridge are all that’s required.
- **Printer stand.** This provides extra space under the 136-column printer.
- **Auto tearoff.** Continuous forms are fed automatically up to the tear-off point at the end of each job.

OPTIONS

Printer options are listed below. For details, see Chapter 8.

- **Cut sheet feeder.** To complement your feeder, a single-bin cut sheet feeder and a double-bin adapter are also available.
- **Color kit.** You can turn your monochrome printer into a color printer.

SETTING UP

Your new printer is easy to install and set up. This chapter tells you how to set up the printer and get started printing right away. If this is your first printer, you should read the entire chapter before attempting to use the printer. In this chapter you will learn how to:

- Position, unpack, and assemble the printer
- Identify the printer's major components
- Connect the power and interface cables
- Test the printer before connecting your computer
- Select an emulation and print using your software

If you have a problem setting up the printer, review the problems and solutions listed in Chapter 7. If the problem persists, contact your dealer.

SELECTING A GOOD LOCATION

This printer is suitable for most business, office, and home environments. To obtain peak performance from the printer, select a location that meets the following guidelines:

- √ Place the printer on a sturdy, level surface.
- √ Place the printer near a well-grounded AC power outlet.
- √ To ensure easy access to the front and rear of the printer, leave several inches of space around the printer. Do not block the air vents on the sides and rear of the printer.
- √ Do not place the printer in direct sunlight or near heaters.
- √ Make sure that the room is well-ventilated and free of excessive dust.
- √ Do not expose the printer to extremes of temperature and humidity.
- √ Use only the power cord supplied with the printer or recommended by your dealer. Do not use an extension cord.

- Do not plug the printer into a power outlet that is shared with heavy industrial equipment (such as motors) or appliances (such as copiers or coffee makers). Such equipment often emits electrical noise or causes power degradation.

UNPACKING

Unpack the printer as follows:

- Open the carton and remove the printer and its components. Make sure that you have all of the items shown below. Note that the ribbon cartridge and power cord supplied depend on the printer model (monochrome or color and 100-120 or 220-240 VAC power supply) and that the printer stand is supplied only for the 136-column printer.

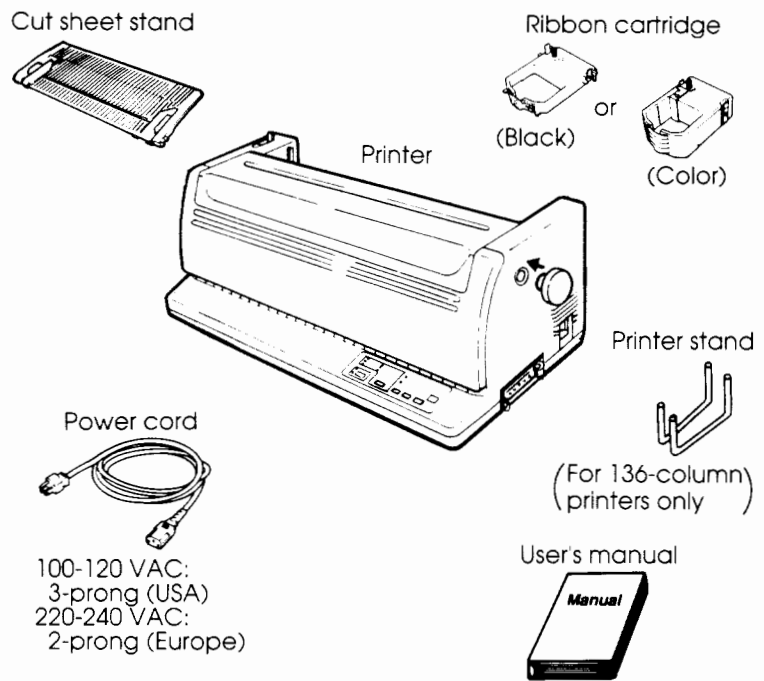

Checking items received

2. Carefully examine each item for possible damage. Report any problems to your dealer or shipping agent.
3. Place the printer where you plan to use it.
4. Remove the tape securing the top and front covers. Open the covers and remove the shipping restraint tie holding the print head carriage in place (shown below).

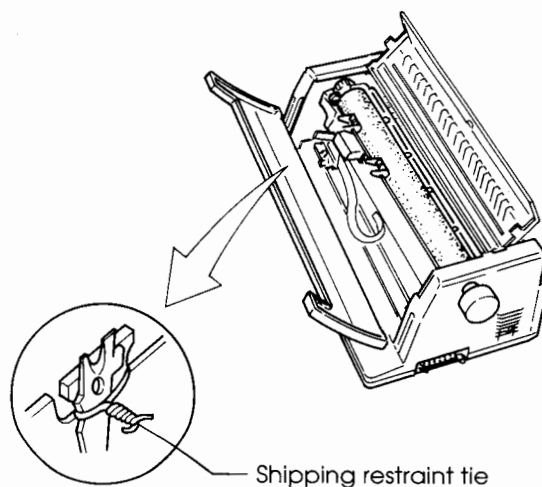

Removing the shipping restraint tie

5. Store the original shipping carton and packaging materials for future use. The original packaging is ideal for moving or shipping your printer to another location.

NOTE

The interface cable is not included with the printer. You must prepare it. See later in this chapter.

Checking Options and Supplies

The following options and supplies are shipped in separate packages:

- Cut sheet feeder
- Double-bin adapter
- Color kit
- Extra ribbon cartridges

Make sure that you received all options you ordered. To install options, see Chapter 8.

Once you are sure you have everything, you're ready to assemble the printer. For information about the printer stand that comes with the 136-column printer, see Chapter 3.

ASSEMBLING THE PRINTER

This section explains how to install the cut sheet stand and ribbon cartridge.

Installing the Cut Sheet Stand

The cut sheet stand allows smooth feeding of both single sheets and continuous forms. To install the cut sheet stand:

1. Referring to the following figure, locate the two grooved notches on top of the printer and behind the top cover. Note that each notch has a front groove and a rear groove.

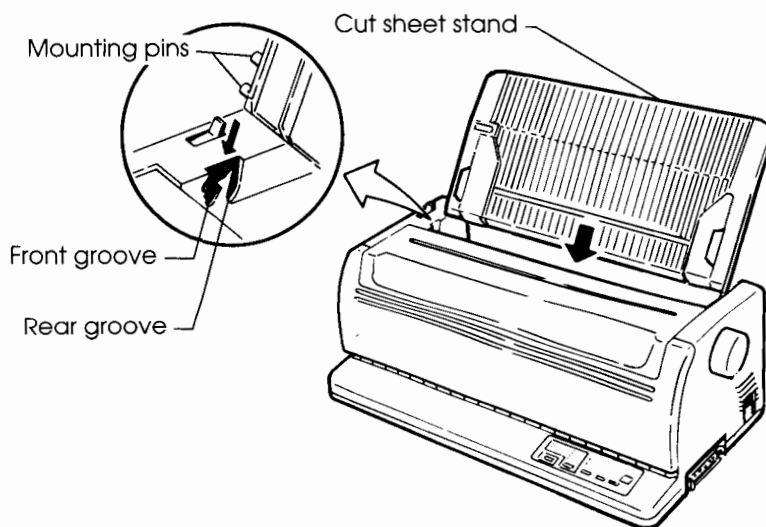

Installing the cut sheet stand

2. Locate the two mounting pins on each side of the cut sheet stand.
3. Tilt the cut sheet stand at an angle over the top of the printer. Slide the cut sheet stand's mounting pins into the long, front grooves of the notches. This is the cut sheet stand's *up* position, used for printing on single sheets.

To rotate the cut sheet stand *down*, grasp it by the sides and lift up until the two upper mounting pins fall into the rear grooves of the notches. This is the position used for printing on most continuous forms paper.

Installing the Ribbon Cartridge

A color printer can use either color or black ribbon cartridges. A monochrome printer *requires* a black ribbon cartridge. To install the ribbon cartridge:

1. Open the top and front covers of the printer. For easy access to the print head carriage, slide it about three quarters of the way to the right side of the platen.
2. Inside the printer, on the right, is the paper thickness lever (shown below). It has the four notches. Before you install the ribbon cartridge, move this lever to ③ or ④.

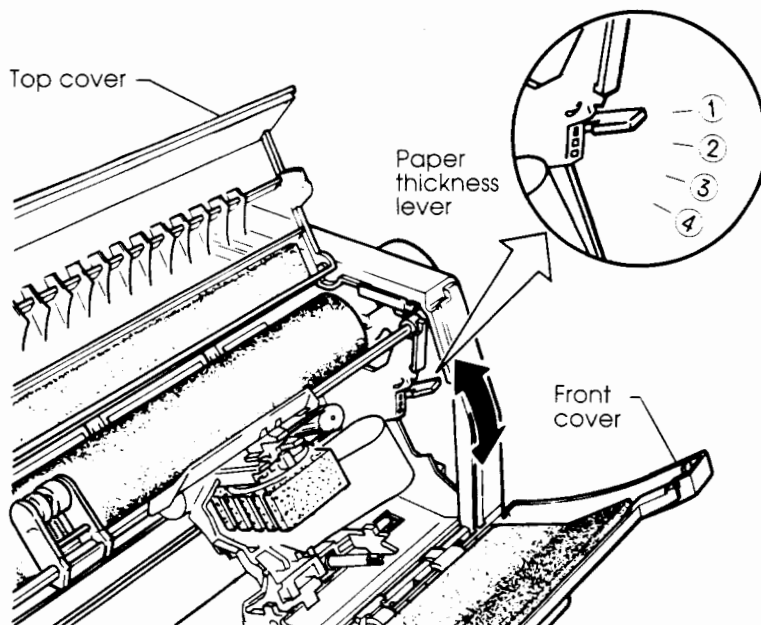

Preparing to install the ribbon

3. Remove the ribbon cartridge from its package. If the ribbon is color, remove the red stopper to release the ribbon feed knob (see the following figure). Turn the ribbon feed knob counterclockwise to be sure it feeds properly.

NOTE

If using a black ribbon, do not remove the plastic ribbon mask protecting the ribbon.

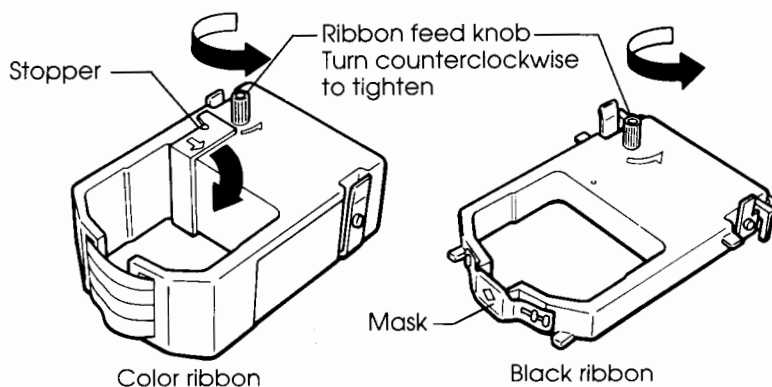
**Preparing the ribbon cartridge**

4. On either side of the ribbon cartridge, locate the two ribbon release levers, each of which has a mounting pin on the side. Referring to the following figure, place the mounting pins onto the ribbon support studs inside the printer. Rotate the cartridge so the ribbon falls between the nose of the print head and the plastic print guide.

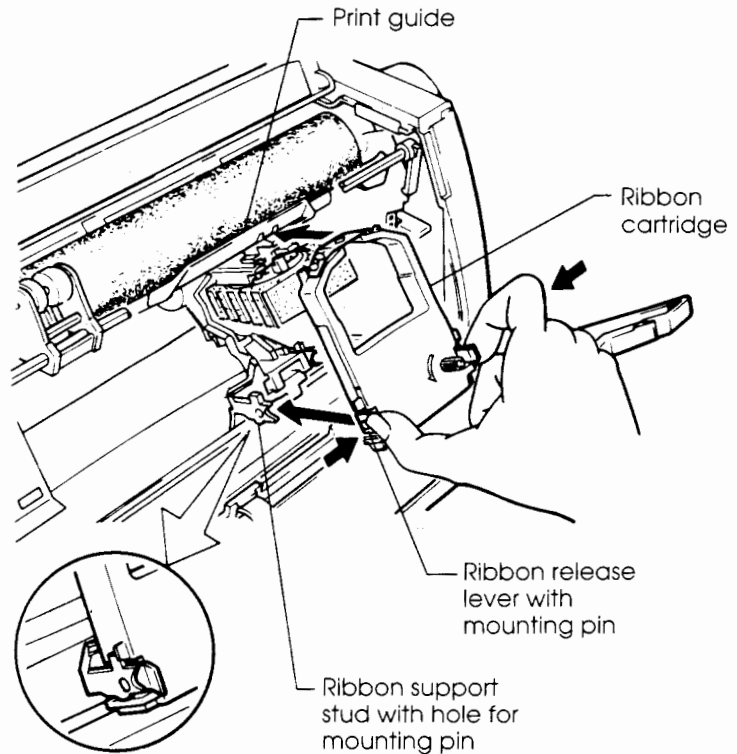

Installing the ribbon cartridge

5. Press the ribbon release levers inward until the mounting pins snap into the holes on the ribbon support studs. Gently pull on the cartridge to be sure that the pins are secure in the holes.
6. Turn the ribbon feed knob counterclockwise to take up any ribbon slack.
7. Move the paper thickness lever back to position ① (uppermost). This is the correct setting for printing most single sheets.
8. Close the front and top covers.

GETTING ACQUAINTED WITH YOUR PRINTER

Now that your printer is assembled, take a moment to become familiar with its major components.

Looking at the printer from the front and right side, you can see the components shown in the figure below.

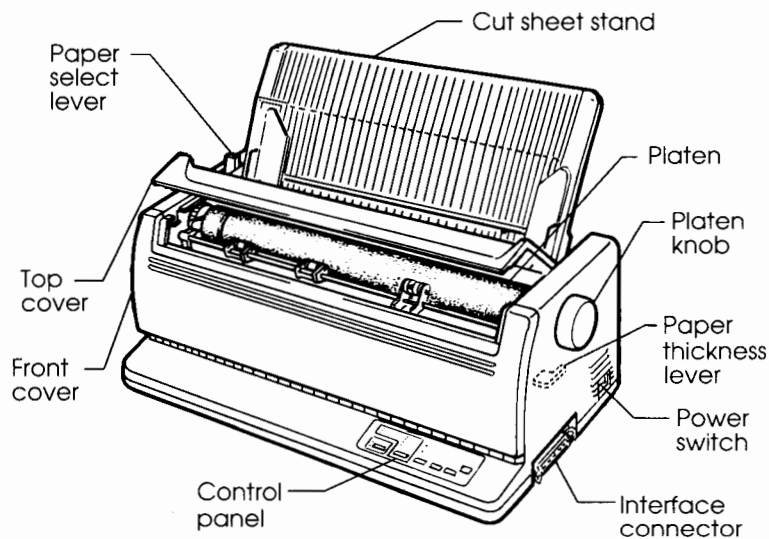

Components on front and side of printer

The printer's control panel contains the buttons and indicators used to load and feed paper (see Chapter 3) and select print features (see Chapter 4). The control panel also allows you to change the printer's optional settings (see Chapter 5).

Looking at the printer from the back, you can see the following components:

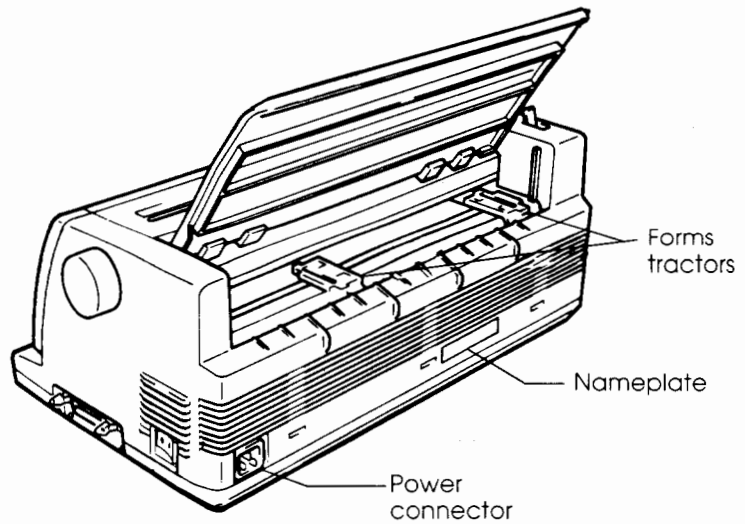

Components on back of printer

CONNECTING THE POWER CORD

Before you plug in the printer:

- √ Make sure that the printer power is switched off. The "0" on the rear of the power switch should be visible.
- √ Make sure that your power outlet is properly grounded.
- √ Make sure that you have the power cord shipped with the printer. This cord is designed to minimize radio frequency interference.

To plug in the power cord:

1. Plug one end of the power cord into the power connector at the right rear of the printer.
2. Plug the other end of the power cord into your power outlet.

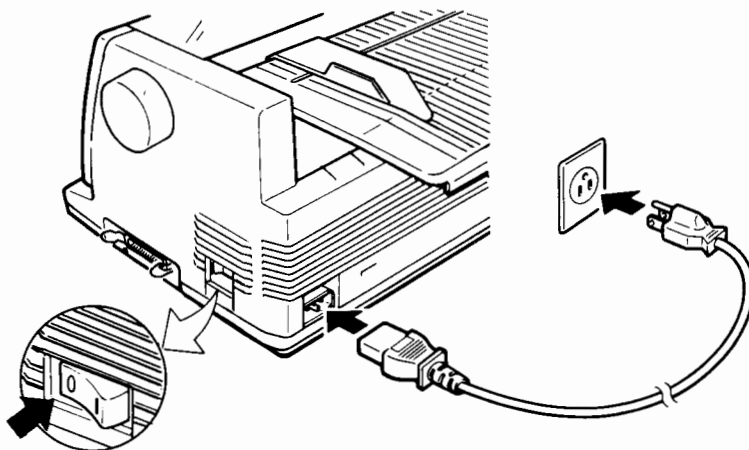

Connecting the power cord

3. Make sure that the power cord is securely connected.
4. To turn on the power, press the "1" on the power switch.
Within a few seconds, some indicators on the printer's control panel light, the print head moves to its home position, and the ONLINE indicator lights (green).

NOTE

Because no forms are loaded, the printer may beep and the PAPER OUT indicator be displayed in red if the paper select lever is set forward to continuous forms. When you move the paper select lever back to the single sheet position (as described in the next section), the PAPER OUT indicator will go out. In other words, this condition poses no problem.

**TESTING THE PRINTER
(OFFLINE)**

At this point, you can load paper and run the printer's self-test. You can use either cut sheets or continuous forms (see Chapter 3). The self-test checks printer performance and print quality before you connect the printer and computer.

Loading Paper for the Self-Test

To print the self-test, use paper greater than 215.9 mm (8-1/2 inches) in width to avoid printing on the platen. Standard letter or A4 size paper can be used by inserting the paper *lengthwise*.

Before loading paper, make sure that the printer is on. Then, do the following:

1. Make sure that the paper thickness lever (inside the right side of the printer) is at position ①. Make sure that the paper select lever (on the top left side of the printer) is set to the back, as shown below.

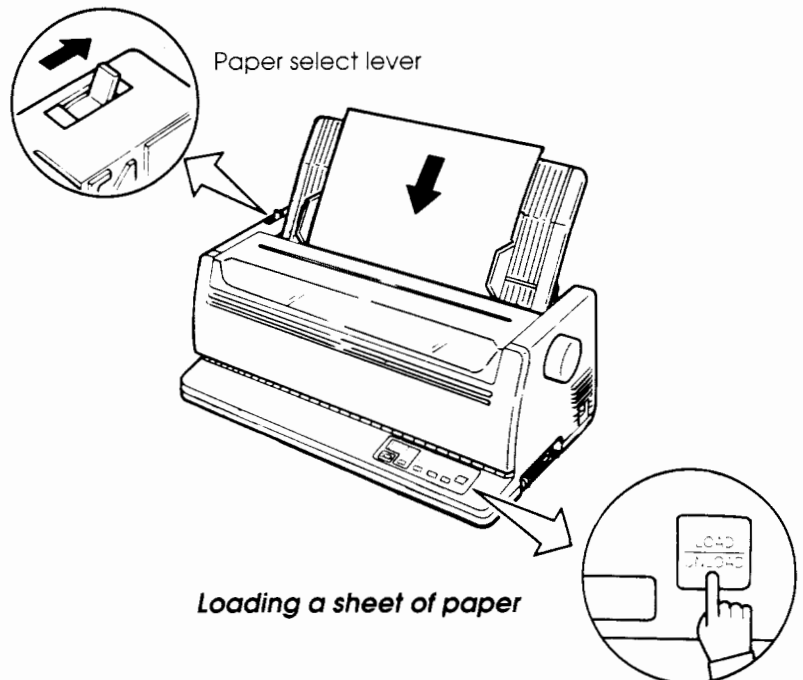

2. Raise the cut sheet stand. Move the left paper guide all the way to the right. Insert a piece of paper into the cut sheet stand. If using paper of letter or A4 size, insert the paper *lengthwise* to avoid printing on the platen.

CAUTION

Printing directly on the platen may damage the platen and print head.

Adjust the right paper guide so that the paper lies flat on the cut sheet stand.

3. Press the LOAD/UNLOAD button. The paper will be loaded to the top-of-form position.

Top-of-form is the base used by the printer to calculate the top margin of the page. The possible top-of-form settings are 25.4 mm (1 inch), which is the factory setting, or 4.2 mm (1/6 inch). The total top margin of your page is the sum of the following settings: top-of-form, the top margin specified in your software, and the top margin specified in the printer's setup mode. See Chapter 5 for information on changing the top-of-form or top margin settings.

Printing the Self-Test

The printer has a built-in self-test program. The self-test prints the firmware version, the names of the printer's resident emulations, and all of the characters available in the emulations. The self-test prints 80 characters per line. If you are using a color printer and ribbon, printing is in seven colors.

Make sure that a piece of paper is loaded. Then follow these steps to print a self-test page.

1. Turn off the printer.

2. While pressing the LF/FF button, turn the printer back on. Continue pressing LF/FF until the printer beeps. Self-test printing will start.

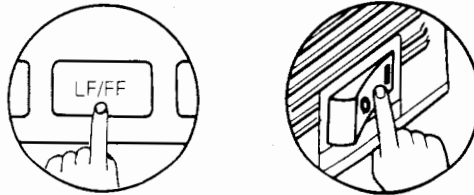

Starting the self-test

3. Allow printing to continue for about 15 seconds. To stop printing, press the MENU SELECT or FONT SELECT button. Manually turn the platen knob clockwise to remove the test page.

NOTE

Do not try to use the LF/FF (line feed/form feed) button to eject the paper. In self-test mode, LF/FF cannot be used to feed paper forward.

4. Look at the self-test page. It should look similar to the sample on the opposite page.

Check that printing is uniform, without light, dark, or smudged areas. If the print quality is good, go to step 5. Otherwise, try to correct the problem using these steps:

- Make sure that the ribbon is installed correctly.
- Make sure that the paper thickness lever is set to position ①.
- Insert a new sheet of paper into the cut sheet stand. Turn the platen knob to manually advance the paper until the top edge has moved past the paper bail rollers.

NOTE

The printer is able to print a special "demo pattern" illustrating some of the printer's capabilities. To print the demo pattern:

1. Load a sheet of letter or A4 size paper.
2. Turn off the printer.
3. While pressing the FONT SELECT button, turn the printer back on. The printer will start printing the demo pattern.
4. To stop the demo, press ONLINE. To restart the demo, press ONLINE again.

==== PRINTER FUNCTION SPECIFICATION ====

Printing technology: 24 wire dot matrix, Logic seeking
 Resolution: Letter quality - 360 X 180 dots/inch
 Draft quality - 120 X 180 dots/inch
 High speed draft - 90 X 180 dots/inch
 Color (Option): 7 colors Black, Magenta, Cyan, Violet, Yellow, Orange, and Green
 Standard command set: Fujitsu DPL24C PLUS Version 1.04
 Resident emulations: Epson LQ2500, LQ2550, IBM Proprinter XL24
 Character sets: Codepage 437, 850, 860, 863, 865, ISO8859-1
 38 national sets, 648 characters per font
 Print functions: See below.
 Fonts - Courier 10, Pica 10, Prestige 12, Boldface PS
 Compression 17, Correspondence 10, Draft 12, Hi-Draft 12
 Dutch PS Upright/*italic*/Bold, Swiss Upright/*italic*/Bold
 OCR-B 10

Bold printing Shadow printing *Italic printing* Underline
 Condensed ^{Superscript} subscript

Double width Double height Double W & H

(The following functions are for the DPL24C PLUS only)

Underline TYPE 1 TYPE 2 TYPE 3 TYPE 4 TYPE 5 TYPE 6 Overline

Bar code print: Codabar, EAN8, EAN13, Code 3 of 9, Industrial 2 of 5
 Interleaved 2 of 5, Matrix 2 of 5, UPC type A

EAN8 example:



Multiwidth & height + Screened outline:

FOR TITLE

Demo pattern

CONNECTING THE PRINTER TO YOUR COMPUTER

Your printer has either a Centronics parallel or RS-232C serial interface. The interface is factory-installed. You can easily check the interface type; the parallel interface connector has wire clips, and the serial interface connector has tapped holes as the fastener. Cables for both interfaces are available from dealers, cable manufacturers, and other suppliers. For detailed interface specifications, see Appendix D.

Selecting a Parallel Interface Cable

For the parallel interface, use a cable that meets the following specifications:

- ✓ At the printer end, use a shielded male Centronics connector such as an Amphenol DDK 57FE-30360 or its equivalent. To prevent RFI (radio frequency interference), the connector cover must be connected to the cable shield.
- ✓ At the computer end, most computers (including IBM PCs) require a male DB-25P connector, but some computers require a Centronics connector. To determine the type of connector your computer uses, refer to your computer's user manual.
- ✓ Make sure that the cable length does not exceed 3 meters (10 feet).

Selecting a Serial Interface Cable

For the serial interface, use a cable that meets the following specifications:

- ✓ At the printer end, use a 25-pin male connector such as a Cannon DB-25P or its equivalent.
- ✓ To determine the type of connector your computer requires, refer to your computer's user manual or ask your dealer.
- ✓ The cable length can be up to 15 meters (50 feet). This length is required in many networking and shared-printer configurations.

Connecting the Interface Cable

To connect the interface cable:

1. Turn off both the printer and the computer.
2. Attach the interface cable to the connector on the right side of the printer. See the following figure.

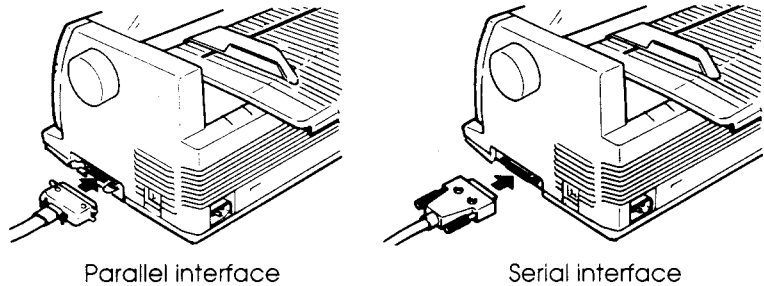

Connecting the interface cable

3. To secure a parallel interface cable, flip the fastener clips on the printer into the notches on the cable connector. To secure a serial interface cable, tighten the screws in the cable connector.
4. Attach the other end of the interface cable to your computer. Gently pull on the cable to verify that it is secure.

SELECTING AN EMULATION

Before printing with your software, you must verify that the correct emulation is selected on your printer. This section explains what emulations are and how to select the emulation you require.

For Experienced Users:

The printer's preselected factory setting is the Fujitsu DPL24C PLUS emulation. If this is the emulation you require, you may skip this section.

An emulation is a set of commands used by your software to communicate with the printer. There are many different emulations available for printers. Each emulation has its own unique features and capabilities. This printer offers four *resident* emulations:

- Fujitsu DPL24C PLUS (for Fujitsu DL-series printers)
- IBM Proprinter XL24
- Epson LQ-2500
- Epson LQ-2550

Resident emulations are stored in the printer's permanent memory.

Here are some pointers to help you determine which emulation to select:

- √ Determine which emulations your software supports. (Refer to your software documentation.) Since most software programs support this printer, you should try to run a program with the factory default emulation first (DPL24C PLUS emulation is the factory default.). Try this even if you are not sure of which emulation to choose. See Chapter 5 for detailed information about how your printer communicates with your software.
- √ If you are using more than one software package, determine which emulation is supported by the software you use most frequently. That's the emulation you should select on the printer.
- √ If your software supports more than one emulation, select the DPL24C PLUS emulation if possible. This is the emulation with the greatest capabilities.
- √ If you want to use an emulation not supported by your software, contact your software manufacturer or printer dealer and ask whether support is available. You may be able to obtain a printer driver not shipped with the original software package.

To select an emulation, follow these steps.

1. Turn on the printer and load a sheet of paper.

To change a single printer setting such as the emulation, you can use single sheet paper. To change several printer settings as described in Chapter 5, however, you must load continuous forms paper. See Chapter 3 for paper loading instructions.

2. Enter setup mode.

Press the ONLINE button to place the printer offline. Then, press the MENU SELECT and FONT SELECT buttons.

As the printer enters offline setup mode, it prints the following information:

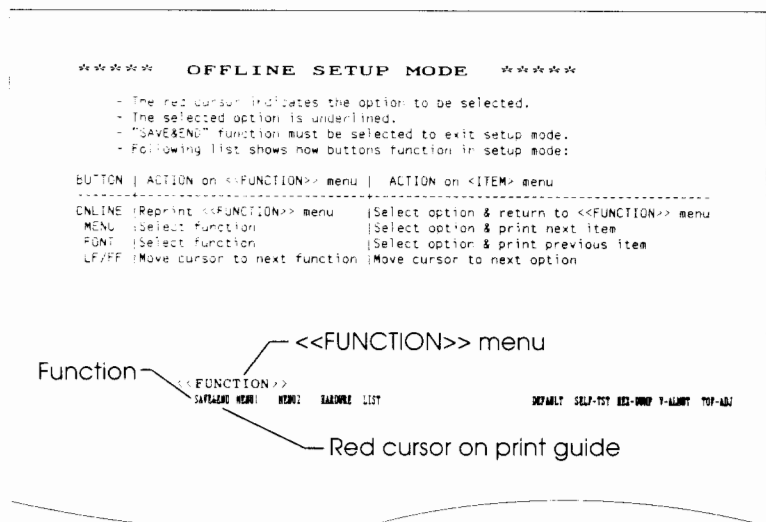

Initial printout in setup mode

Make sure that the <<FUNCTION>> menu (shown in the above figure) is printed at the bottom of the page.

3. Select the MENU1 function.

Look for the red cursor on the plastic print guide. Initially, it should be positioned below SAVE&END at the beginning of the <<FUNCTION>> menu. Repeatedly press LF/FF to position the red cursor beneath MENU1, as shown below:

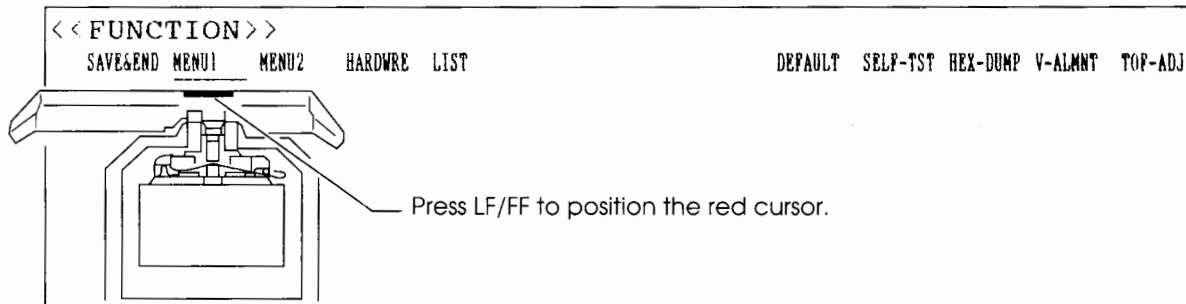

Press MENU SELECT or FONT SELECT to select MENU1 and print the <EMULATE> options:



The currently selected emulation is indicated by a short underline. In the figure above, the Fujitsu DPL24C PLUS emulation is selected.

4. Select an emulation.

Repeatedly press LF/FF to position the cursor beneath the emulation you require. Press MENU SELECT or FONT SELECT to select the emulation and print the next MENU1 item.

5. Exit MENU1.

Press ONLINE to exit the MENU1 function and reprint the <<FUNCTION>> menu.

6. Exit setup mode, saving the emulation.

To exit setup mode and save the new emulation, make sure that the red cursor is positioned beneath SAVE&END. Then press MENU SELECT or FONT SELECT. The printer selects SAVE&END, then goes online.

To change other printer settings using setup mode, see Chapter 5.

PRINTING A SAMPLE PAGE (ONLINE)

Once the self-test verifies that the printer is functioning correctly, try printing using one of your software package. This will ensure that the printer is correctly connected to your computer.

If you are using a parallel interface, the printer usually prints the correct characters. You may need to adjust the page layout or various print features using your software or the printer's setup mode. However, if you are using a serial interface, it is possible that the printer will not work at all, or that it will print a lot of "?" characters. This means that the serial settings on the printer do not match those on your computer or in your software. Before changing these settings, use the following procedure to try printing using the printer's preselected factory settings.

To test communication between the printer and computer, follow these steps.

1. Load a piece of paper.
2. Check that the printer is online. The ONLINE indicator should be green. If it isn't, press the ONLINE button.
3. Try to print using your word processor, a programming language, or other software.
4. If the page layout or other print features are wrong, use your software's printer selection menus or the the printer's setup mode, described in Chapter 5, to make the changes you require.

If the printer does not print or prints the wrong characters, take the following steps:

- Make sure that the interface cable is properly connected.
- Make sure that the printer emulation selected in your software is the same as the emulation selected on the printer.
- If you are using a serial interface model, make sure that the printer's serial interface settings are the same as those on the computer. The printer's preselected factory settings are 8 data bits, no parity, 1 stop bit, 9600 baud, and XON/XOFF protocol.

You can change the serial settings on either the printer or your computer. To change the printer's settings, see Chapter 5. To change the computer's settings, use the selection menus provided by your software or the commands provided by your computer's operating system. An example using the MS-DOS operating system is given below. If the printer still doesn't work, consult your dealer or someone experienced in serial interface communications.

Using MS-DOS to Specify Serial Interface Settings

For an IBM PC or a compatible device, the following MS-DOS MODE commands are used to set the computer's serial settings to match the printer's factory settings:

```
MODE COM1 : 9600 , N , 8 , 1 , P  
MODE LPT1 : =COM1
```

To activate these settings whenever you turn the computer on, include the MODE commands in your AUTOEXEC.BAT file. Make sure that the MODE.COM file is included in your root directory.

You are now finished setting up and testing the printer. To familiarize yourself with everyday printer operations such as loading paper, selecting print features, and printing, see Chapters 3 and 4.

3

LOADING AND USING PAPER

This chapter explains how your printer uses paper. Topics are covered in this order:

- Selecting paper
- Overview of paper operations
- Adjusting for paper thickness
- Using single sheets
- Using continuous forms
- Feeding paper
- Switching paper types

Tips for handling paper are given at the end of this chapter. If you are using multipart forms, envelopes, or labels, check this section.

SELECTING PAPER

The printer can handle either single sheets or continuous forms. Single sheets, also called cut sheets, include envelopes and noncontinuous multipart forms. Continuous forms include labels and multipart forms fed into the printer using the rear forms tractors.

For best results, be sure that your paper meets the specifications listed below. See Appendix B for detailed specifications. If the specifications of your paper are unclear, try testing the paper or consult your dealer.

Length	Single sheets: 76 to 364 mm (3 to 14.3 in) Continuous forms: 102 mm (4 in) or greater	
Width	110 columns	Single sheets: 102 to 330 mm (4 to 13 in) Continuous forms: 102 to 330 mm (4 to 13 in)
	136 columns	Single sheets: 102 to 420 mm (4 to 16.5 in) Continuous forms: 102 to 406 mm (4 to 16 in)
Thickness	0.3 mm (.012 in) maximum total thickness. For envelopes, the maximum thickness of the multilayer part can be up to 0.5 mm (0.02 in).	
Copies	1 to 4 copies, including the original. For carbon-interleaved paper, the carbon counts as a copy.	

OVERVIEW OF PAPER OPERATIONS

The following levers and buttons are used to handle paper in your printer:

- Paper select lever, located on the top left corner of the printer
- Paper thickness lever, located inside the front cover on the right side of the printer
- LF/FF, TEAR OFF, and LOAD/UNLOAD buttons on the control panel

The figure below shows the location of each lever and button.

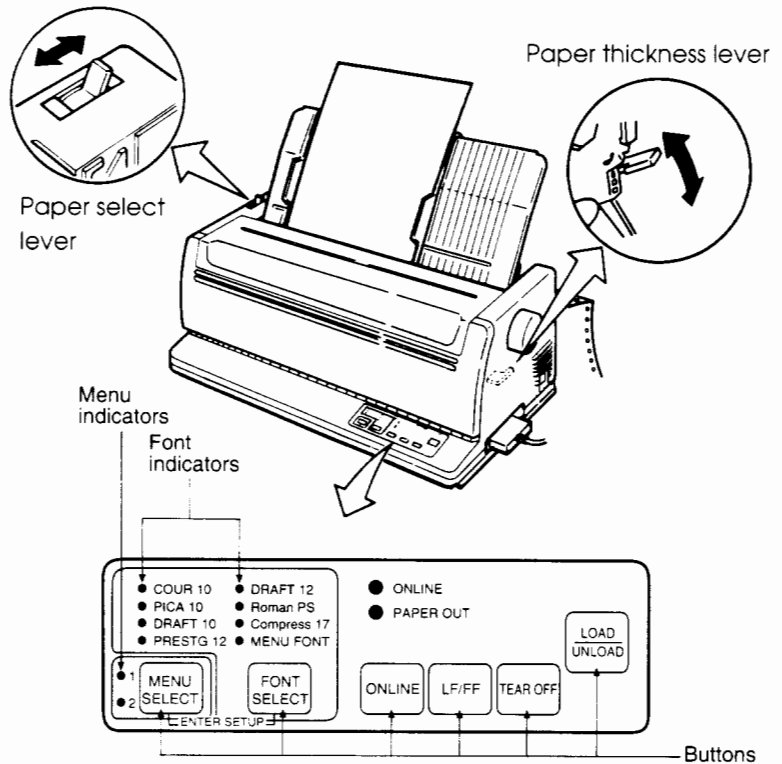

Printer levers and buttons

Table 3.1 summarizes how levers and buttons handle paper. More detailed information is provided later in this chapter.

NOTE

To load or advance paper, the printer must be in one of these three conditions: not receiving data, not printing data, and not in setup mode.

Table 3.1 Paper Handling Levers and Buttons

Lever/Button	Purpose	What You Do
LF/FF	Form feed Line feed	Press and hold LF/FF to execute a form feed. Continuous forms are fed forward by one page. Single sheets are ejected. Press LF/FF within three seconds to feed paper forward by one line.
TEAR OFF	Advance forms for tear-off	Press TEAR OFF to advance forms to the tear-off edge. Tear off the forms, then press any button to retract the forms.
LOAD/ UNLOAD	Load/unload paper	Press LOAD/UNLOAD to load paper, or to unload (retract) continuous forms to the "park position."
Paper select lever *	Select the paper path	Move the paper select lever backward for single sheets (cut sheet stand or feeder). Move the paper select lever forward for continuous forms.
Paper thickness lever	Adjust for paper thickness or number of copies	Move the paper thickness lever to position ① to ④. Use ① for 1 copy. Use ① or ② for 2 copies (including original). Use ② for 3 or 4 copies (including original). Use ③ for envelopes or labels.

* The following marks are engraved on the cover.



Continuous forms



Cut sheets

ADJUSTING FOR PAPER THICKNESS

The printer can handle paper of different thicknesses. This includes multi-part forms with up to four parts (original plus three copies). For detailed paper thickness specifications, see Appendix B.

The paper thickness lever, located inside the front cover on the right side of the printer, allows you to adjust for different paper thicknesses. Be sure to adjust the paper thickness lever whenever you change the number of copies being printed.

To adjust the paper thickness lever:

1. Open the top and front covers of the printer.

CAUTION

The print head may be hot if you've been printing recently.

2. Locate the paper thickness lever, shown in the figure below.

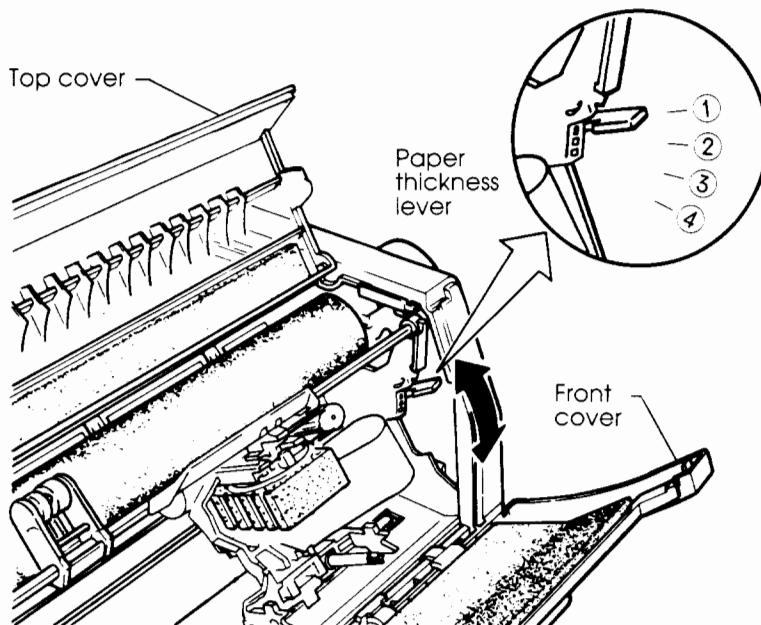

Adjusting the paper thickness lever

3. The paper thickness lever has four positions: ①, ②, ③, and ④. Use the following table to determine the appropriate setting for your paper. Then, move the paper thickness lever to the appropriate position.

Table 3.2 Paper Thickness Lever Settings

Number of Copies (Including Original)*	Position
1 copy	①
2 copies	① or ②
3 to 4 copies	②
Labels, envelopes Ribbon replacement	③

* For carbon-interleaved paper, the carbon counts as one copy.

NOTE

If printing is messy, the ribbon misfeeds, or the paper jams, move the lever one notch higher.

USING SINGLE SHEETS

This section explains how to load paper in the cut sheet stand or cut sheet feeder. The cut sheet stand allows paper to be loaded manually one sheet at a time. A cut sheet feeder allows paper to be automatically loaded from a stack.

Loading a Single Sheet of Paper

To load a sheet of paper into the cut sheet stand:

1. Make sure that the printer is turned on. Check that continuous forms are retracted to the park position (see **Unloading Continuous Forms** later in this chapter for details).
2. If necessary, re-adjust the paper thickness lever (see **Adjusting for Paper Thickness** earlier in this chapter).

3. Move the paper select lever (on the top left side of the printer) to the rear.
4. Raise the cut sheet stand. Position the left paper guide.

NOTE

When the left paper guide is positioned all the way to the right, you will obtain a left margin of 11 mm (7/16) inch, plus the left margin specified using your software or the printer's setup mode. To help align paper, use the two inch-based rulers on the top cover of the printer. The upper gradations on the ruler show 10 columns per inch. The lower show 12 columns per inch.

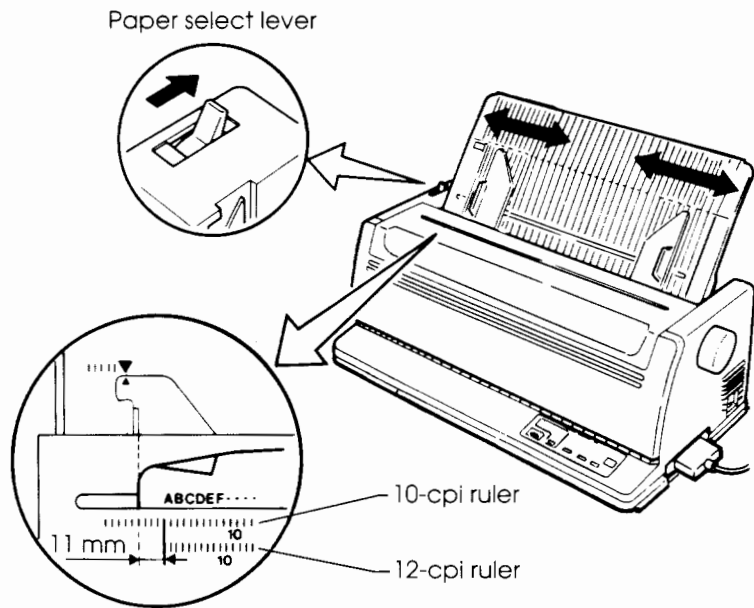

Preparing to load a sheet of paper

5. Insert a sheet of paper into the cut sheet stand. Make sure that the bottom edge of the paper snugly engages with the platen. Adjust the right paper guide.

6. Press the LOAD/UNLOAD button. The paper will advance to the top-of-form position. Top-of-form is the first line on which printing can start. To adjust the position of the paper slightly, manually turn the platen knob.

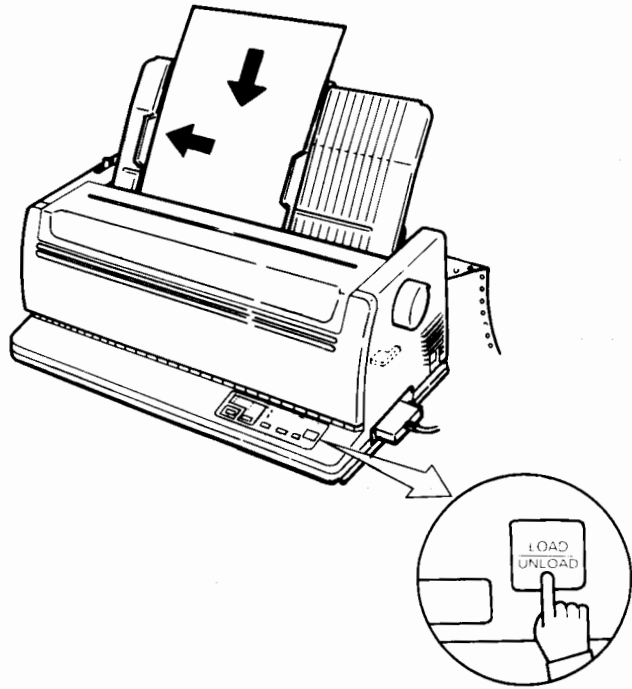

Loading a sheet of paper

7. Place the printer online. Print a sample page and check the margins of the page. If necessary, adjust the following:
 - Horizontal alignment of the paper. Re-adjust the paper guides if required.
 - Top-of-form setting (see Chapter 5)
 - Margin settings. Use your software or the printer's setup mode (see Chapter 5).

Loading Paper in the Cut Sheet Feeder (Option)

A cut sheet feeder allows you to automatically print on single sheets without inserting the sheets one by one. This can save you a lot of time when printing long files using single sheets. See Chapter 8 for more information on cut sheet feeders.

When the feeder is mounted, you must enter the printer's setup mode and specify either SINGLE or DOUBLE as the feeder type. Otherwise, the feeder will not work. To enter setup mode and specify the feeder type, see **Changing Hardware Options** in Chapter 5.

To load paper in the cut sheet feeder:

1. Make sure that the printer is turned on. Check that continuous forms are retracted to the park position (see **Unloading Continuous Forms** later in this chapter for details).
2. If necessary, re-adjust the paper thickness lever (see **Adjusting for Paper Thickness** earlier in this chapter).
3. Move the paper select lever (on the top left side of the printer) to the rear.
4. Referring to the figure below, prepare the cut sheet feeder as follows:

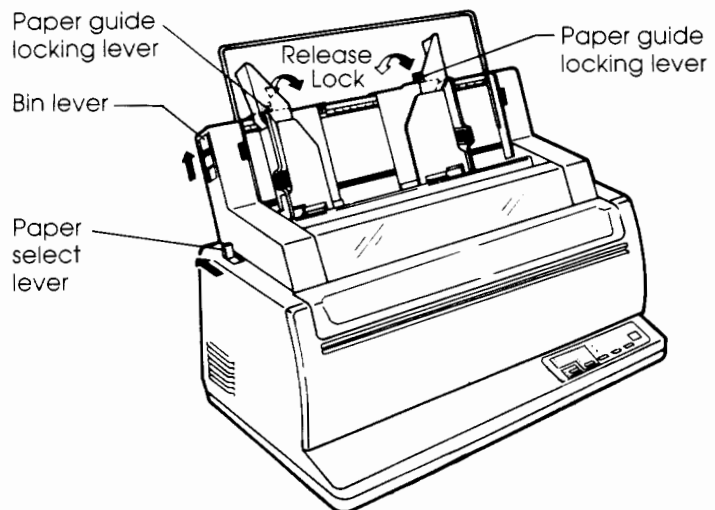

Preparing the cut sheet feeder

- To open the paper bin, push the bin lever up to "OPEN." The bin lever is located on the left side of the feeder.
- Push back both of the paper guide locking levers of the feeder.
- Position the left paper guide. Pull the left locking lever forward to secure the left paper guide.

NOTES

- To help align the left paper guide, use the inch-based ruler located behind the paper guides. The ruler is subdivided into 10 columns per inch. Setting the left paper guide 12.7 mm (1/2 inch) from the left provides a left margin of 6.3 mm (1/4 inch), plus the left margin specified using your software or the printer's setup mode.
- The vertical mark near the base of the left paper guide (shown in the figure below) indicates the location of the printer's paper-out sensor. This groove is on the left side of the platen. Do not position the left paper guide to the right of this vertical mark, or your paper will not load properly.

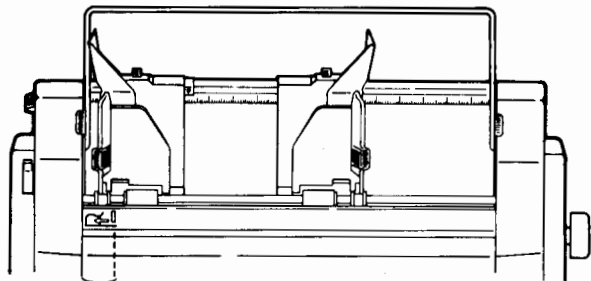

Make sure that the left edge of your paper falls within this area.

- Slide the right paper guide to the approximate width of your paper.

5. Manually fan the stack of paper and place it in the paper bin. See the following figure.

NOTE

A short vertical mark inside each paper guide indicates the maximum capacity of the bin. Make sure that your paper stack does not exceed these vertical marks.

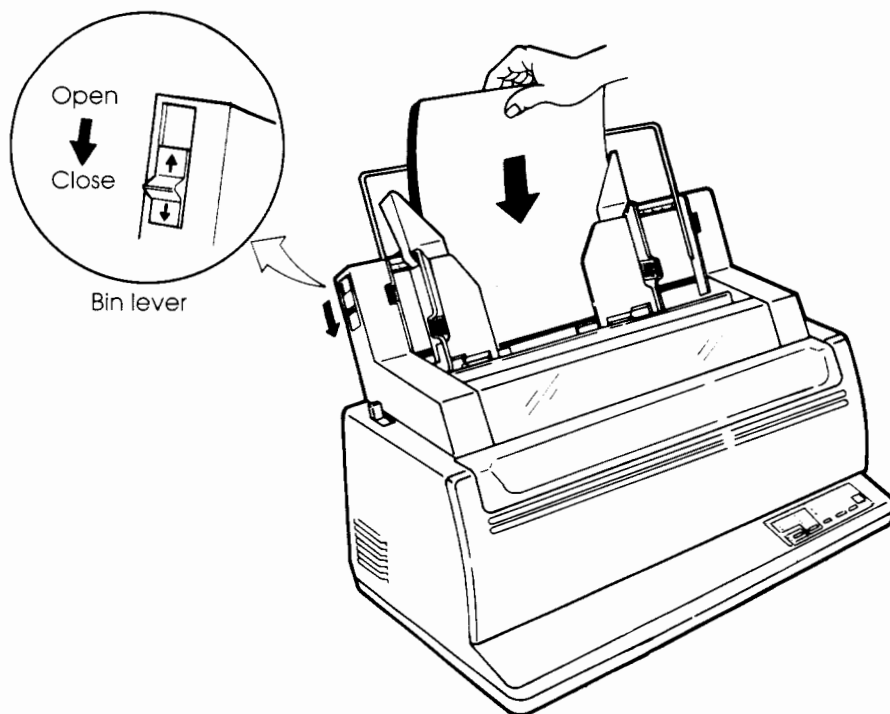

Loading the cut sheet feeder

6. Re-adjust the right paper guide, leaving a slight gap between the paper guide and the right edge of the paper. About 1.5 mm (1/16 inch) is sufficient. Pull the right locking lever forward.
7. Push the bin lever down to "CLOSED."

8. To load paper to the top-of-form position, use one of the following methods:
 - Load the paper *manually* . Press the LOAD/UNLOAD button. The paper advances to the top-of-form position. Adjust the position of the paper as needed by using the platen knob.
 - Load the paper *using software*. Press ONLINE to place the printer online. Load paper according to the instructions in your software documentation. Most software packages load paper automatically.
9. Place the printer online. Print a sample page and check the margins of the page. If necessary, adjust the following:
 - Horizontal alignment of the paper stack. Re-adjust the paper guides if required.
 - Top-of-form setting (see Chapter 5)
 - Margin settings. Use your software or the printer's setup mode (see Chapter 5).

Ejecting Single Sheets

If you print using software, each sheet is automatically ejected when the end of the printed page is reached. To manually eject sheets of paper, use one of the following methods:

- Press and hold down LF/FF to execute a forward form feed.
- Turn the platen knob clockwise.

USING CONTINUOUS FORMS

Continuous forms paper, fanfolded at the horizontal perforations, is fed into the printer using the rear forms tractors. Forms paper is ideal for printing rough drafts and long files.

Positioning the Paper Stack

Place the stack of forms paper directly below the rear of the printer. After the paper is installed in the printer, the paper path will look like this:

Single-part and side-glued multi-part forms

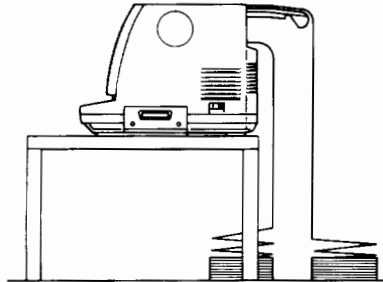

Paper-stapled multi-part forms

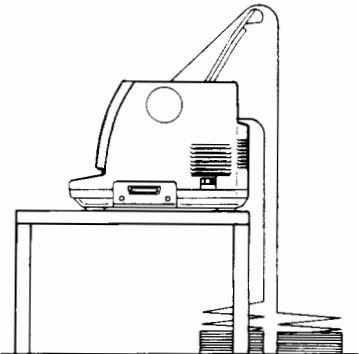

Placement of continuous forms

Installing the Printer Stand

The 136-column printer has a stand that raises the printer 7 cm.

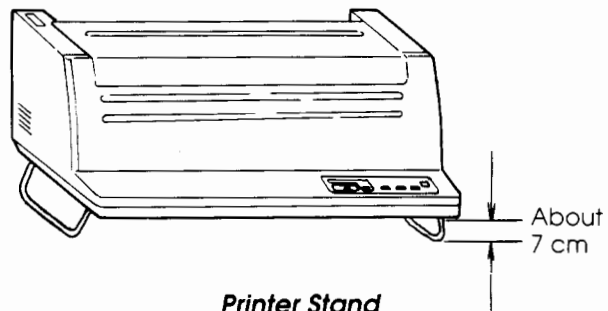

Printer Stand

The printer stand consists of two steel rod feet that bend slightly outward. To install the printer stand:

1. Turn off the printer and tip the printer backward to access the bottom.
2. Insert the ends of one foot into the two holes for the left stand and the other foot for the right stand as shown in the figure below.

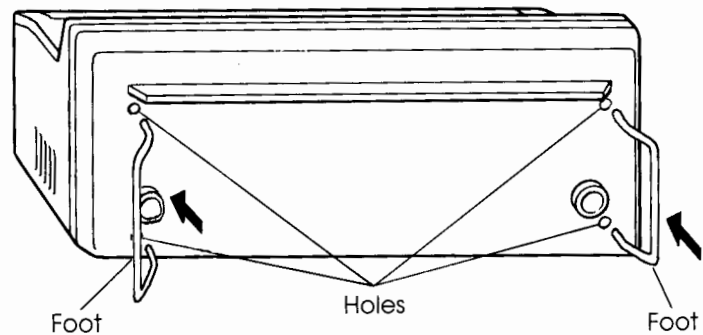

Printer stand (bottom)

Loading Continuous Forms

If you have a cut sheet feeder installed, you must remove it to load continuous forms paper. To load forms paper:

1. Make sure that the printer is turned on. Remove any single sheet paper from the printer.
2. If necessary, re-adjust the paper thickness lever for continuous forms (see **Adjusting for Paper Thickness** earlier in this chapter).

3. Move the paper select lever (shown below) forward.

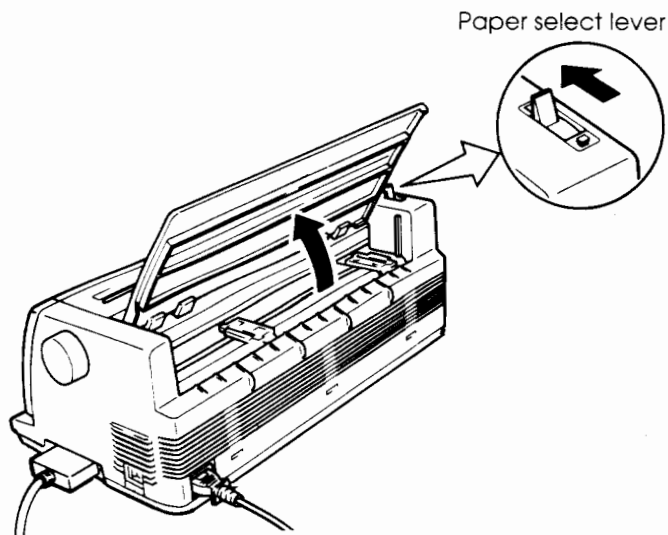

Preparing to load forms paper

4. Raise the cut sheet stand, if installed.
5. Release the tractor locking levers by pushing them toward the front of the printer. See the following figure.

CAUTION

Be careful to release the locking levers before moving the tractors. Otherwise, you may damage the levers.

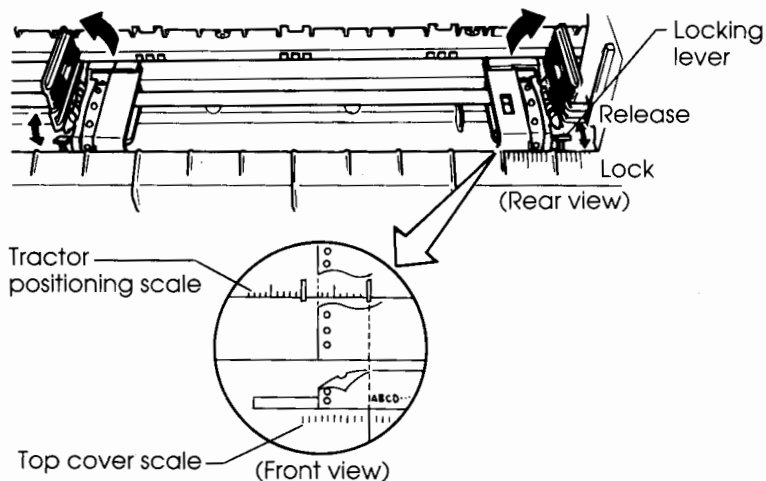

Positioning the tractors

6. Position the right tractor (as seen from the rear of the printer). Pull the right locking lever toward the rear of the printer to secure the tractor. Center the middle forms support.

NOTE

Below the right tractor, as seen from the back, there is a short inch-based ruler with 10 columns per inch. The leftmost graduation indicates the left edge of the first character as shown above.

7. Open the tractor paper holders and fit the form's feed holes onto the left and right tractor pins. Adjust the left tractor (as seen from the rear of the printer) to the width of the form. Close the paper holders.

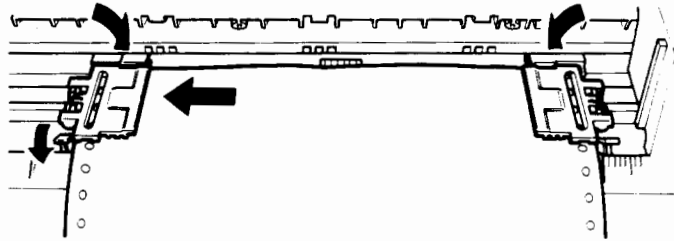

Installing forms paper (rear view)

8. Pull the left tractor (as seen from the rear) to stretch the paper taut. Pull the left locking lever to the rear to secure the tractor in place.
9. If using the cut sheet stand, raise it to the up position for paper-stapled multi-part forms. For other forms paper, lower the cut sheet stand to the down position.
10. Press the LOAD/UNLOAD button to advance the paper to the top-of-form position. Top-of-form is the first line where printing can start.
11. Press the ONLINE button to place the printer online. Print a sample page and check the margins of the printed page. If necessary, adjust the following:
 - Horizontal alignment of the paper. Move the forms tractors as required.
 - Top-of-form setting (see Chapter 5)
 - Margin settings. Use your software or the printer's setup mode (see Chapter 5).

Unloading Continuous Forms

To unload continuous forms:

1. Make sure that the paper select lever is set to the forward position.
2. Press the LOAD/UNLOAD button. The continuous forms are then retracted to the park position. If forms cannot be retracted in one operation, continue to press LOAD/UNLOAD until the paper is parked.

NOTE

The printer can retract forms a maximum of 55.8 cm (22 inches) per operation.

3. To remove the forms, raise the tractor paper holders and lift out the paper.

Tearing Off Forms

Your printer has a special "tear-off edge" that allows you to remove printed pages without wasting paper. The tear-off edge is located on the top cover.

To tear off continuous forms using the tear-off edge:

1. Press the TEAR OFF buttons. The paper advances to the tear-off edge.

Do not press the TEAR OFF button if you specified TEAR OFF: AUTO using the HARDWRE function in setup mode. The paper automatically advances to the tear-off edge at the end of each job (or when the printer has printed all the data received).

NOTE

If the bottom perforation of your paper is not positioned at the tear-off edge, it may indicate that the length of your paper is not correctly specified in your software or the printer's setup mode. Check that the paper length is correctly specified. For information on specifying page length using setup mode, see Chapter 5.

2. Tear the paper off at the perforation.

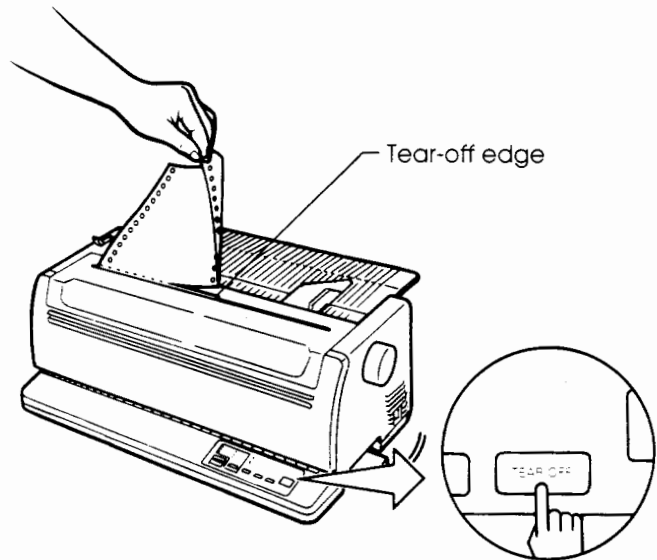

Tearing off continuous forms

3. Press any button to retract the forms back to the top-of-form position.

FEEDING PAPER

Use the LF/FF (line feed/form feed) button on the control panel to move paper forward. This button functions in both online and offline.

The printer does not allow you to execute "reverse" form or line feeds from the control panel. To move paper backwards, manually rotate the platen knob.

Pressing and holding down the LF/FF button feeds one sheet of paper. Pressing the LF/FF button once advances the paper one line (do not hold the button more than three seconds).

SWITCHING PAPER TYPES

If you have more than one type of job, it is often convenient to switch between using continuous forms and single sheets. This section explains how to switch back and forth between paper types. It is not necessary to remove the continuous forms paper from the printer.

Switching to Single Sheets

To switch from continuous forms to single sheets:

1. Tear off your printed pages.
2. Retract the forms paper to the park position (press LOAD/UNLOAD). The PAPER OUT indicator turns red.

CAUTION

Failure to retract the forms paper will cause paper jams.

3. Move the paper select lever to the rear (single sheet) position.
4. Mount the cut sheet stand or cut sheet feeder. See **Using Single Sheets** earlier in this chapter for details. If you are using the cut sheet stand, press the LOAD/UNLOAD button to advance the paper to the top-of-form position. If you are using the cut sheet feeder, the paper advances to the top-of-form position by a command from the computer. In this case, you cannot advance paper from the control panel.

You are now ready to print using single sheets.

Switching to Continuous Forms

To switch from single sheets to continuous forms:

1. If a sheet of paper is loaded, turn the platen knob or press and hold down the LF/FF button to remove it.

CAUTION

Failure to remove paper may cause a paper jam.

2. Move the paper select lever to the forward (continuous forms) position.
3. Press the LOAD/UNLOAD button. The continuous forms paper advances to top-of-form.

You are now ready to print using continuous forms paper.

TIPS ON HANDLING PAPER

General Tips

- Use high-quality paper. Do not use paper that is wrinkled or curled at the edges.
- Do not use paper with staples or metal parts.
- Do not use paper with unpredictable variations in thickness, e.g., partially multiple paper, paper with embossed printing, and labels with the backing sheet exposed.
- Store paper in a clean, dry environment.
- When manually loading paper using the platen knob, press the ONLINE button to move the print head to the home position. This prevents the paper from being caught by the bail rollers.
- Check paper placement and alignment each time you use the printer. For long print jobs using continuous forms, periodically make sure that paper is stacked correctly.

Multipart Forms

- Do not print using more than four parts (original plus three copies). For carbon-interleaved forms, be sure to count the carbon as a copy.

- Avoid using carbon-interleaved single sheets. Printing tends to become misaligned on the bottom sheet.
- To ensure smoother feeding of paper-stapled multi-part forms, raise the cut sheet stand as a support behind the forms.

Envelopes

To print on envelopes, use the cut sheet stand or the manual feed slot of the cut sheet feeder. Note the following:

- Use envelopes with a maximum thickness of 0.5 mm (0.02 inch) at the multilayer part.
- Set the paper thickness lever to position ③.
- When loading envelopes, make sure that the flaps of the envelopes face forward. Otherwise, jamming may occur.
- Make sure that the print area specified by your application software is within the printable area of the envelope. Printing past the edge of the envelope will damage the print head and platen. To make sure that printing will occur in the correct area, print a sample using standard size paper.

Labels

- Be careful to use labels under normal operating conditions. Labels are sensitive to temperature and humidity.
- Only use labels mounted on continuous forms backing sheets. Do not print labels mounted on single sheet backing. Labels mounted on single sheet backing tend to slip and print crooked.
- Set the paper thickness lever to position ③.
- Do not feed labels backwards using unload (LOAD/UNLOAD) from the control panel. Jamming may occur.
- Do not use the printer's tear-off feature. When the labels are retracted, they may peel off the backing and become jammed in the printer.
- Do not leave labels loaded in the printer where they can become curled around the platen. Jamming may occur when you resume printing.
- Test-print labels before using them. If jams occur, set the paper thickness lever to position ④. If jamming problems continue, try a different type of label.

PRINTING

This chapter describes everyday printing operations. To load paper for printing, see Chapter 3. Then use the procedures in this chapter to:

- Select print features
- Start, stop, or resume printing
- Remove printed pages
- Clear the print buffer

SELECTING PRINT FEATURES

The print features you select determine how your printed pages will look. Print features include the following:

- Print quality
- Fonts
- Pitch (characters per horizontal inch)
- Page length and width
- Line spacing (lines per vertical inch)
- Color

To select print features, you can use either commercial software or the printer's control panel. Which method you use depends on the capabilities of your software. If your software has most of the features you require, you may rarely — if ever — have to use the control panel. *In fact, your software often overrides the printer's settings.*

If your software has limited options, you can use the printer's control panel to select print features. Sometimes the control panel enables you to select features not selectable by software. For example, you can select downloaded fonts not supported by your software.

Using Commercial Software

Many of today's commercial software packages offer a wide variety of print features, including features not possible with this printer. For example, software often provides a wider range of font sizes than the printer. It also allows you to specify multiple fonts on a page and multi-color printing. To determine which features your software supports and how to select them, refer to your software documentation.

Using the Control Panel

Using the MENU SELECT and FONT SELECT buttons, you can directly select from the following menus and fonts listed on the printer's control panel:

- Select one of the two menus
- Select one of the specific resident fonts

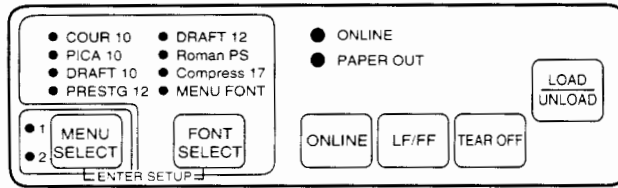

Printer control panel

MENU SELECT specifies menu 1 or 2 in which you can specify different sets of options in advance. Some of the print features include emulation, print quality, character pitch, and line spacing.

FONT SELECT specifies one of the specific resident fonts which are represented by font names and pitches. Resident fonts are Courier 10, Pica 10, Draft 10, Prestige 12, Draft 12, Roman PS, and Compressed 17. However, if you select MENU FONT, the printer uses the font and pitch depending on MENU1 or MENU2 specified by the MENU SELECT button.

This chapter does not explain how to assign values to options in the menu.

If you haven't already assigned values to MENU 1 and MENU 2, go to Chapter 5 now.

When you first turn the printer on, all of the print features assigned to MENU1 are active. However, you can easily switch to MENU2 before printing. You can also select a specific resident font different from those already assigned to MENU1 and MENU2.

To select these print features (MENU1 or MENU2 and one of the specific resident fonts), use the MENU SELECT and FONT SELECT buttons to make certain indicators turn on. See the following for details.

NOTE

For easy reference, it's a good idea to keep a list of your current MENU 1 and MENU 2 settings near the printer. To print a list of current settings, see *Printing a List of Selected Options* in Chapter 5. You may also want to use the space provided in Table 4.1 to record your settings.

Selecting MENU1 or MENU2

When you first turn the printer on, MENU1 is active. To change to MENU2 or back to MENU1, follow these steps:

1. Press ONLINE to place the printer offline.
2. Repeatedly press MENU SELECT. The lighted indicator shows the selected feature. Unselected features do not light.

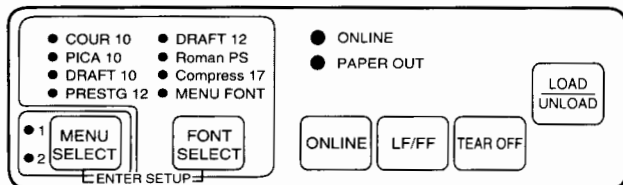

Table 4.1 MENU1 and MENU2 Settings

Possible Settings	Default Settings <i>For easy reference, check (✓) or mark your default settings in the space below.</i>	
Print Feature	MENU1	MENU2
Emulation Fujitsu DPL24C PLUS IBM Proprinter XL24 Epson LQ-2500 Epson LQ-2550		
Print quality Letter Report Draft High-speed draft		
Font Courier 10 Prestige Elite 12 Compressed 17 Boldface PS Pica 10 Correspondence font Dutch PS Upright Dutch PS Italic Dutch PS Bold Swiss PS Upright Swiss PS Italic Swiss PS Bold OCR-B 10 Download font 0 Download font 1		
Pitch 2.5, 3, 5, 6, 10, 12 15, 17, 18 or 20 cpi Proportional spacing		
Other features:		

3. To change to a specific resident font, see the next section. Otherwise, press ONLINE to return online. You are now ready to print using the selected menu.

Changing the menu font to a specific resident font

Before printing, you can use the control panel to select a specific resident font. You won't need to do this if you just selected a menu (either MENU1 or MENU2) with the appropriate font. To change the menu font to a specific resident font:

1. Make sure that the printer is offline.
2. Repeatedly press FONT SELECT. The lighted indicator shows the selected feature. Unselected features do not light.

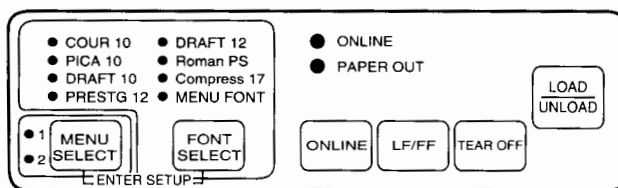

COUR 10:	Courier font at 10 cpi
PICA 10:	Pica font at 10 cpi
DRAFT 10:	Draft font at 10 cpi
PRESTG 12:	Prestige Elite font at 12 cpi
DRAFT 12:	Draft font at 12 cpi
Roman PS:	Roman font proportionally spaced
Compress 17:	Compressed font at 17 cpi

3. Press ONLINE to return online for printing. You are now ready to print using the selected menu and specific resident font.

NOTE

Selecting MENU FONT activates the MENU1 or MENU2 font settings.

PRINTING**Start Printing**

Before you start to print, make sure that paper is loaded. Also, verify that the paper thickness lever is set to the appropriate position (①, ②, or ③).

To start printing, use the commands provided by your software or computer.

Stop Printing

To stop printing immediately, press the ONLINE button to place the printer offline. You can also use your software to stop printing, but there will be a slight delay before printing stops. Any data sent to the print buffer but not yet printed is stored until you resume printing. Data in the print buffer is lost if you turn the printer off.

To resume printing, press ONLINE again. To cancel printing, use the cancel commands provided by your software or computer. To clear the print buffer, turn the printer off. Any data sent to the print buffer before you canceled will be lost.

Resuming from Paper-Out

The printer can “sense” when paper runs out. Depending upon how PPR-OUT (paper-out) is set in setup mode, the printer either:

- Stops printing and turns on the red PAPER OUT indicator, or
- Continues printing until no more data remains in the printer

See Chapter 5 for details on setting PPR-OUT. The factory default is to stop printing when continuous forms paper runs out, and to continue printing when the cut sheet stand is empty.

CAUTION

When using the cut sheet stand, be careful not to run out of paper while printing. Printing on the platen may damage the platen and the print head.

If the cut sheet feeder runs out of paper, the printer always stops printing, regardless of the PPR-OUT setting.

To resume printing when paper runs out:

1. Install paper on the forms tractors or in the cut sheet feeder bin. See Chapter 3 for details.
2. To load the first sheet of paper, press LOAD/UNLOAD. The PAPER OUT indicator will turn off.

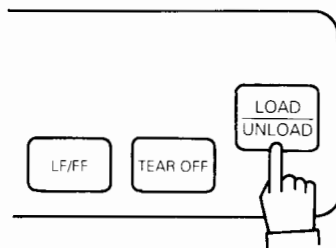

3. Press the ONLINE button to place the printer online and resume printing.

NOTE

For continuous forms, the page where printing stopped and the page where printing resumes will probably be incorrectly printed. Wait for the entire job to finish printing. Then reprint these pages.

REMOVING PRINTED PAGES

This section describes the best methods for removing single sheets or continuous forms paper after printing.

Removing Single Sheets

When you print using software, the printer automatically ejects each sheet of paper when the end of the printed page is reached. To eject sheets manually, use one of the following methods:

- Press and hold down the LF/FF button to execute a form feed
- Turn the platen knob clockwise

Removing Continuous Forms

To avoid wasting paper, use the printer's tear-off edge to remove continuous forms paper. Press the TEAR OFF buttons to advance the perforation to the tear-off edge. Tear the paper off, then press any button to retract the paper back to the top-of-form position. See Chapter 3 for more detailed instructions.

CLEARING THE PRINT BUFFER

Turning the printer off clears all data from the print buffer. This is useful when you cancel a print operation and do not want to continue printing data already sent to the printer. When you turn the printer on again, it reverts to its power-on defaults.

USING SETUP MODE

Your printer has two modes: normal and setup. *Normal mode* is used for everyday printer operations and is explained in Chapters 3 and 4.

Setup mode serves two purposes. It enables you to:

- Select the printer's optional settings
- Help diagnose printer problems

These setup mode services can be done offline using the printer control panel (offline setup) or remotely using a setup program in your computer system or software (online setup). This chapter explains how to use the offline setup mode. Online setup mode, mentioned at the end of this chapter, is valid in all emulations. For details, refer to the programmer's manuals.

Optional settings on the printer include the emulation, fonts, pitch, page length and width, serial interface options, and the top-of-form setting. When you save your settings in the printer's permanent memory, they become the new settings, or defaults. These defaults are active whenever you turn on the printer. For example, if you save DPL24C PLUS as the default emulation, DPL24C PLUS is active when you turn on the printer.

The printer's diagnostic functions are SELF-TST, HEX-DUMP, and V-ALMNT. These functions are helpful for printer troubleshooting, which is described in Chapter 7. HEX-DUMP is also used by programmers to print hex dumps.

HOW TO USE THIS CHAPTER

The sections in this chapter are presented in a logical sequence. *If you are a first-time user, read the following sections first:*

- Entering Setup Mode
- Overview of Setup Mode

These sections will familiarize you with how setup mode works. Once you understand the basics, use the following sections to select printer options which are compatible with your computer system's hardware and software setup:

- Printing a List of Selected Options
- Deciding Which Options to Change
- Changing MENU1 and MENU2 Options
- Changing Hardware Options
- Changing Top-of-Form
- Exiting and Saving

To restore the printer's default settings (factory defaults or power-on defaults), see **Resetting Defaults**.

For information on using the SELF-TST, HEX-DUMP, and V-ALMNT functions, see **Using the Diagnostic Functions**.

For Experienced Users:

Once you are familiar with setup mode, you may want to use the flowchart at the end of this chapter for quick reference. All printer setup functions, items, and options are listed in the flowchart.

ENTERING SETUP MODE

Before entering setup mode, load continuous forms paper into the printer (see Chapter 3 for paper loading instructions). Several sheets of paper may be required to make all of your setup selections.

To enter setup mode, follow these steps.

1. Make sure that continuous forms paper is loaded and that the paper select lever is set to the forward position.
2. Press ONLINE to place the printer offline.

3. Press the MENU SELECT and FONT SELECT buttons simultaneously until the printer beeps.

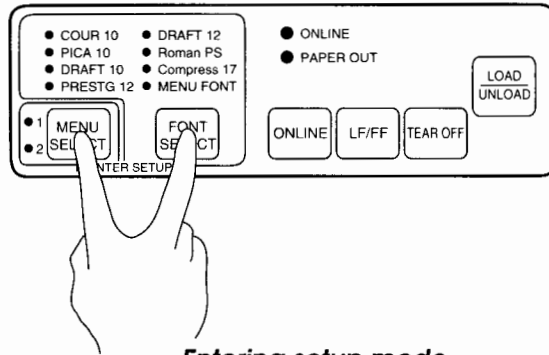

Entering setup mode

If you do not hear a beep, you are not in setup mode. Place the printer offline and try again.

4. The printer enters offline setup mode and prints the following information.

Help menu

```

***** OFFLINE SETUP MODE *****

- The red cursor indicates the option to be selected.
- The selected option is underlined.
- "SAVE&END" function must be selected to exit setup mode.
- Following list shows how buttons function in setup mode:

BUTTON | ACTION on <<FUNCTION>> menu | ACTION on <ITEM> menu
-----|-----|-----
ONLINE | Reprint <<FUNCTION>> menu | Select option & return to <<FUNCTION>> menu
MENU   | Select function | Select option & print next item
FONT   | Select function | Select option & print previous item
LF/FF  | Move cursor to next function | Move cursor to next option
        
```

Function ———— <<FUNCTION>> menu

 <<FUNCTION>>

SAVE&END HEAD1 HEAD2 HARDWARE LIST DEFAULT SELF-TEST REZ-DUMP Y-ALIGN TOP-A0J

 Red cursor on print guide

Initial printout in setup mode

The initial printout contains a header, a help menu, and a <<FUNCTION>> menu. The header tells you that the printer is offline and in setup mode. The help menu provides a quick summary of how to use setup mode. Finally, the <<FUNCTION>> menu lists all of the functions available to you in setup mode. Note that the red cursor on the plastic print guide is initially positioned below the SAVE&END function.

Another way to enter setup mode is to turn off the printer, then turn on the printer while pressing the MENU SELECT button. Continue pressing the button until the printer beeps.

OVERVIEW OF SETUP MODE

When you enter setup mode (as described in the previous section), the <<FUNCTION>> menu is always printed as shown below.

```

<<FUNCTION>>
SAVE&END  MENU1  MENU2  HARDWRE  LIST                DEFAULT  SELF-TST  HEX-DUMP  V-ALMNT  TOP-ADJ
    
```

The purpose of each function is briefly described in the table below.

Table 5.1 Setup Functions

Function	Purpose
SAVE&END	Exit setup mode and save any changes made while in setup mode.
MENU1 and MENU2	Assign print features to MENU1 and MENU2 on the printer's control panel.
HARDWRE	Change the printer's hardware options.
LIST	Print a list of all currently selected options.

Table 5.1 Setup Functions (Cont.)

Function	Purpose
DEFAULT	Reset factory defaults in MENU1 and MENU2.
SELF-TST	Run the self-test.
HEX-DUMP	Print hex dumps.
V-ALMNT	Check and correct vertical print alignment.
TOF-ADJ	Set top-of-form.

To select a function from the <<FUNCTION>> menu:

1. Repeatedly press LF/FF to position the red cursor on the plastic print guide beneath the function you require.
2. Press MENU SELECT to select the function. If the function has items and options, the printer prints the first item and its options. The MENU1, MENU2, HARDWRE, and TOF-ADJ functions contain items that have selectable options. The other functions do not have items or options.

For example, the first three MENU1 items and their options are shown below. Items are enclosed in brackets < >.

< EMULATE >	<u>DPL24C+</u> IBMXL24	LQ2500	LQ2550
< FONT >			
<u>COUR 10</u> PRSTG12	COMPRSD BOLDPCE PICA 10	CORRESP	DTCH-UM DTCH-IM DTCH-UB SWIS-UM
SWIS-IM SWIS-UB	OCR-B DOWNLDO DOWNLDI		
< QUALITY >	<u>LETTER</u> REPORT	DRAFT	HI-DRFT

To select an option from the <item> menu:

1. Repeatedly press LF/FF to position the red cursor on the plastic print guide beneath the option you require.
2. Press MENU SELECT to select the option. The printer prints the next item and its options.
3. After selecting the desired options, press ONLINE to reprint the <<FUNCTION>> menu.

For each item, the option with a short underline beneath it is the current default option (the option currently saved in the printer's permanent memory). In the previous example, the default options are Fujitsu DPL24C PLUS emulation, Courier 10 font, and letter print quality.

The chart on the following page summarizes how to select options such as the emulation, font, and print quality. It also summarizes how to use the buttons with functions not having options.

Setup Mode Example

To become familiar with setup mode, try the following example. This example shows how to change the font and pitch in MENU2 to Prestige Elite 12 and 12 cpi.

1. **Load continuous forms paper.**
2. **Enter setup mode.**

Press the MENU SELECT and FONT SELECT buttons at the same time until the printer beeps.

3. **Select the MENU2 function.**

Wait for the printer to stop printing and press LF/FF twice to position the red cursor on the print guide beneath MENU2. Press MENU SELECT to select the MENU2 function and print the <EMULATE> item and its options.

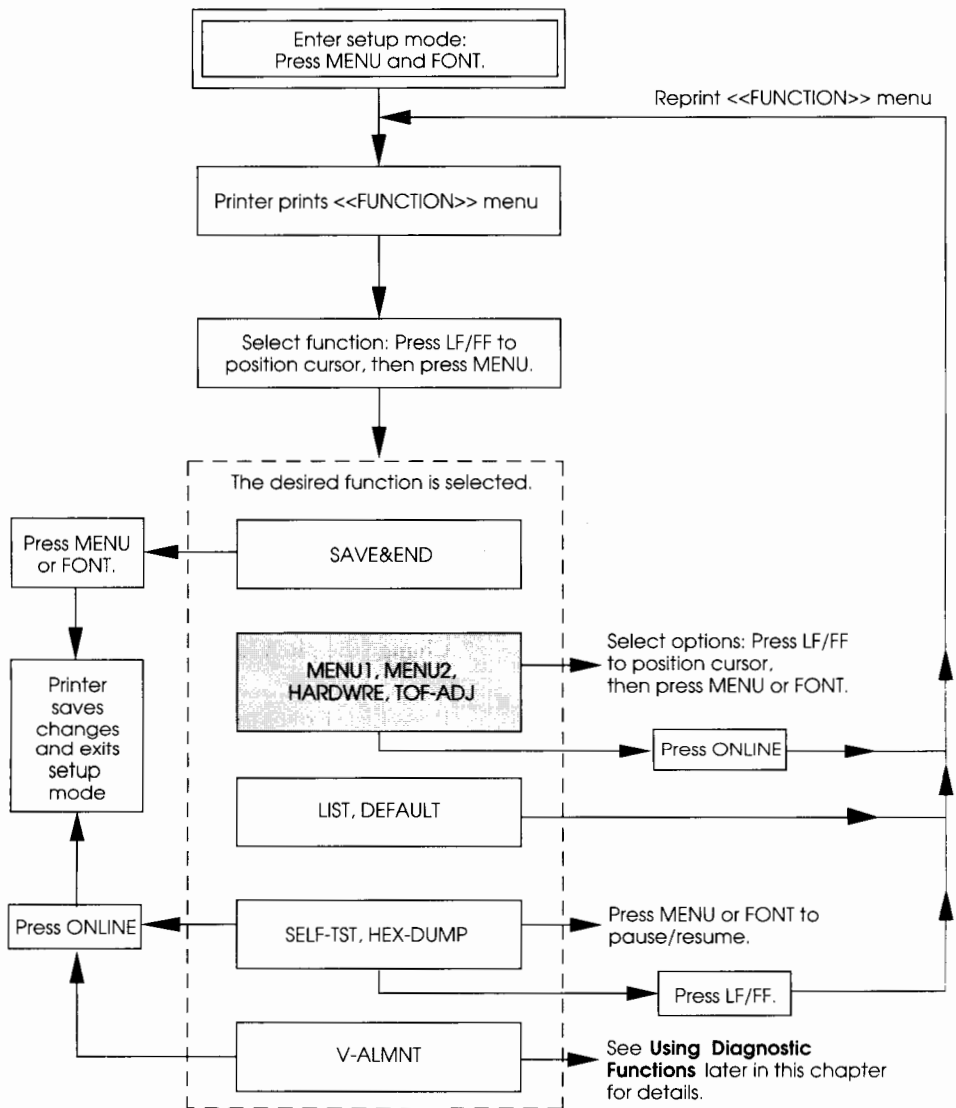

□ : Functions with items and options.

MENU: MENU SELECT

FONT: FONT SELECT

Setup Mode

Summary of setup mode

4. Select the current emulation.

Since you do not want to change the emulation, press MENU SELECT to select the current emulation and print the item and its options.

5. Change the font to Prestige Elite 12.

Press LF/FF once to position the cursor beneath PRSTG12. Press MENU SELECT to select PRSTG12 and print the next item, <QUALITY>, and its options.

6. Select the current print quality.

Since you do not want to change the print quality, press MENU SELECT to select the current print quality and print the next item, <PITCH>.

7. Change the pitch to 12 cpi and exit the MENU2 function.

Press LF/FF once to position the cursor beneath 12 CPI. Since you do not want to make any other changes in MENU2, press ONLINE to select 12 CPI and exit MENU2. The <<FUNCTION>> menu is then reprinted. If necessary, check setting results by selecting SELF-TST to print test pages.

8. Exit setup mode, saving the new font and pitch.

Check that the cursor is beneath SAVE&END. Press MENU SELECT to select SAVE&END. The printer saves Prestige Elite 12 and 12 cpi as the new power-on defaults in MENU2. It then exits setup mode and returns online. These settings remain in effect until changed.

Points to Remember

- Load continuous forms paper *before entering setup mode*. In setup mode, the LF/FF and LOAD/UNLOAD buttons cannot be used to load or feed paper. To load paper in setup mode, use the platen knob.
- Whenever you enter setup mode, short help menus are printed at the top of the page. Help menus are also printed when you select the SELF-TST, HEX-DUMP, or V-ALMNT functions. Use help menus for quick reference while in setup mode.
- When printing the items and options for each function, you can only print one item at a time. However, you can move either forward or backward in the item list. To move forward (print the next item), press MENU SELECT. To move backward (print the previous item), press FONT SELECT.
- While in the <<FUNCTION>> menu or when selecting a function that contains items and selectable options, press ONLINE to reprint the <<FUNCTION>> menu.
- A short underline beneath the first two letters of an option indicates that it is the current default setting. For example, 12 CPI indicates that 12 characters per inch is the default pitch. To change the default, you must select and save a new pitch setting.
- While in setup mode, you can use the LIST function to print out a list of the currently selected options (see the next section for details).
- To exit setup mode and permanently save your changes, you must select either the SAVE&END function or the SELF-TST function. For details, see the section **Exiting and Saving** later in this chapter. To exit setup mode without saving your changes, turn the printer off. Your previous power-on defaults are active when you turn the printer on again.

**PRINTING A LIST OF
SELECTED OPTIONS**

The LIST function prints a list of all the printer's currently selected options. This function is useful for checking the printer's settings when you first enter setup mode or just before you exit. To print a list of options, load continuous forms paper. Then follow these steps.

1. Enter setup mode.

Press MENU SELECT and FONT SELECT simultaneously. Wait for the printer to stop printing and check that the <<FUNCTION>> menu is printed as shown below.



2. Select the LIST function.

Repeatedly press LF/FF to position the red cursor beneath LIST. Next press MENU SELECT. The printer selects LIST and starts to print a list of the currently selected options. The preselected factory settings, also called factory defaults, are shown on the opposite page.

When the printer finishes printing the list of options, it reprints the <<FUNCTION>> menu.

NOTE

To remove the printout, turn the platen knob until the paper can be torn off at the perforation. In setup mode, you cannot use the printer's tear-off feature (TEAR OFF button).

3. Do one of the following:

- Select another function.
- Exit setup mode, saving any changes you made.

For details about other functions, see the other sections in this chapter. To exit setup mode and save your changes, make sure that the red cursor is positioned beneath SAVE&END, then press MENU SELECT.

```

*** Setup parameters ***

<< Menu 1 settings >>
-----
Func.  |Item  |Option
-----
MENU1  |EMULATE|DPL24C+
MENU1  |FONT   |COUR 10
MENU1  |QUALITY|LETTER
MENU1  |PITCH  |10 CPI
MENU1  |LINE SP|6 LPI
MENU1  |CHAR-W |NORMAL
MENU1  |CHAR-H |NORMAL
MENU1  |ATTRIB |NONE
MENU1  |PAGE LG|11.0 IN
MENU1  |COLOR  |AUTOSEL (*1)
MENU1  |LFT-END|1 COLM
MENU1  |TOP-MRG|1 LINE
MENU1  |LANGUGE|PAGE437
MENU1  |CHR-SET|SET 2
MENU1  |PRF-SKP|NO-SKIP
MENU1  |WIDTH  |13.6 IN
MENU1  |ZEROFNT|NO-SLSH
MENU1  |DC3-CDE|ENABLE
MENU1  |CR-CODE|CR ONLY
MENU1  |LF-CODE|LF & CR
MENU1  |RGHTEND|WRAP
MENU1  |==END==|
-----

<< Menu 2 settings >>
-----
Func.  |Item  |Option
-----
MENU2  |EMULATE|DPL24C+
MENU2  |FONT   |COUR 10
MENU2  |QUALITY|LETTER
MENU2  |PITCH  |10 CPI
MENU2  |LINE SP|6 LPI
MENU2  |CHAR-W |NORMAL
MENU2  |CHAR-H |NORMAL
MENU2  |ATTRIB |NONE
MENU2  |PAGE LG|11.0 IN
MENU2  |COLOR  |AUTOSEL (*1)
MENU2  |LFT-END|1 COLM
MENU2  |TOP-MRG|1 LINE
MENU2  |LANGUGE|PAGE437
MENU2  |CHR-SET|SET 2
MENU2  |PRF-SKP|NO-SKIP
MENU2  |WIDTH  |13.6 IN
MENU2  |ZEROFNT|NO-SLSH
MENU2  |DC3-CDE|ENABLE
MENU2  |CR-CODE|CR ONLY
MENU2  |LF-CODE|LF & CR
MENU2  |RGHTEND|WRAP
MENU2  |==END==|
-----

<< Hardware settings >>
-----
Func.  |Item  |Option
-----
HARDWRE|PPR-OUT|CNTONLY
HARDWRE|PRT-DIR|BI-DIR
HARDWRE|BUZZER |ON
HARDWRE|WORD-LG|8 BIT
HARDWRE|BUFFER |8KBYTE
HARDWRE|FEEDER |REAR
HARDWRE|FORMAT |8NONE 1
HARDWRE|BAUD-RT|9600
HARDWRE|PROTOCL|XON/XOF } (*2)
HARDWRE|DSR     |IGNORE
HARDWRE|DUPLEX  |FULL
HARDWRE|TEAROFF|MANUAL
HARDWRE|==END==|
-----

<< Top of form settings >>
-----
Func.  |Item  |Option
-----
TOF-ADJ|ORIGIN |1 INCH
TOF-ADJ|FINEADJ|0
TOF-ADJ|==END==|
-----

```

*1 Color models
*2 Serial interface models

Printout of factory defaults using LIST

Setup Mode

**DECIDING WHICH
OPTIONS TO CHANGE**

On the previous page, a printout of the printer's factory default settings is shown. In this printout, options are listed by functional group:

- Menu 1 settings (MENU1 function)
- Menu 2 settings (MENU2 function)
- Hardware settings (HARDWRE function)
- Top-of-form settings (TOF-ADJ function)

Most selectable options only alter print features such as the typestyle, page format, and color selection. However, some options must be selected correctly for the printer to work properly with your hardware and software. For each function, Table 5.2 lists those items whose options must be selected correctly for system and printer accessory compatibility.

Table 5.2 Required Options

Function	Item	Required Options
MENU1	EMULATE	<p>The emulation selected on the printer must be the same as the emulation selected in your software. If you selected an emulation when you set up the printer (Chapter 2), you do not need to change the EMULATE option unless you want to switch to a different emulation. The emulation assigned to MENU1 is the default when you turn the printer on.</p> <p>See the section Changing MENU1 and MENU2 Options later in this chapter.</p>

Table 5.2 Required Options (Cont.)

Function	Item	Required Options
MENU2	None	Options for the MENU2 function should only be changed if you plan to select MENU2 from the control panel. In this case, <i>the emulation selected for MENU 2 must be the same as the emulation selected in your software.</i> See the section Changing MENU1 and MENU2 Options later in this chapter.
HARDWRE	FEEDER FORMAT BAUD-RT PROTOCL DSR DUPLEX	Change the FEEDER option if you install a cut sheet feeder. If the single or double bin option is not correctly specified, the feeder will not work. <i>If you have a serial interface model, the serial interface options selected on the printer must be the same as the settings you selected using your software or your computer's operating system. If settings are not the same, the printer will not print or will print garbage.</i> See the section Changing Hardware Options later in this chapter.
TOF-ADJ	None	If you are not using software to specify the top margin of the page, use the printer's default top-of-form setting (1 inch (25.4 mm) from the top of the page). If you are using software to specify the top margin of the page, change the default setting to 1/6 inch (4.2 mm). See the section Changing Top-of-Form later in this chapter.

CHANGING MENU1 AND MENU2 OPTIONS

The MENU1 and MENU2 functions allow you to change the print options assigned to MENU1 and MENU2 on the printer's control panel. In normal (non-setup) mode, you can easily switch back and forth between the menus for printing. See Chapter 4 for details.

The MENU1 and MENU2 items and options are listed in Table 5.3. Both functions offer the same items and options. The items in Table 5.3 are listed in the order in which they are printed. For emulations, some items are not defined and some options differ with emulations.

MENU1 is active when you first turn the printer on.

You must select the same emulation on the printer as in your software. If the emulations are not the same, the printer will not work correctly with your software. If you plan to use two different emulations on a regular basis, assign the most frequently used emulation to MENU1. Assign the other emulation to MENU2. All of the other settings available for MENU1 and MENU2 are optional. Some of the items and options will differ with emulations.

To determine which features your software supports, refer to your software documentation. If you have a color printer, the default for <COLOR> is AUTOSEL, which allows you to specify color using your software.

The procedure for changing the MENU1 and MENU2 options follows Table 5.3.

Table 5.3 MENU1 and MENU2 Items and Options

NOTES:

- Underlined options are the factory defaults.
- Asterisks show items and options that differ for the IBM XL24 and Epson LQ-2500/LQ-2550 emulations. See the end of this table for the meanings.

MENU1 and MENU2 Items	Options	Description
<EMULATE>	<p><u>DPL24C+</u></p> <p>IBMXL24</p> <p>LQ2500</p> <p>LQ2550</p>	<p>Select the same emulation as the one selected in your software. See the section Selecting an Emulation in Chapter 2 for pointers on selecting an emulation.</p> <p>Fujitsu DL-series printers (DPL24C PLUS command set)</p> <p>IBM Proprinter XL24 printers</p> <p>Epson LQ-2500 printers</p> <p>Epson LQ-2550 printers</p> <p>NOTE: When you select a new emulation, all MENU1 or MENU2 options are reset to the factory defaults for that emulation.</p>
	<p><u>COUR 10</u></p> <p>PRSTG12</p> <p>COMPRSD</p> <p>BOLDFCE</p> <p>PICA 10</p> <p>CORRESP</p> <p>DTCH-UM</p> <p>DTCH-IM</p> <p>DTCH-UB</p>	<p>For each font below, the recommended pitch settings are given in parentheses. When you change the font, be sure to also change the pitch, if required.</p> <p>Courier, 10cpi</p> <p>Prestige Elite, 12cpi</p> <p>Compressed font, 15,17,and 18cpi</p> <p>Boldface, Proportional</p> <p>Pica, 10cpi</p> <p>Correspondence, 10cpi</p> <p>Dutch 801 Normal, Proportional</p> <p>Dutch 801 Italic, Proportional</p> <p>Dutch 801 Bold, Proportional</p>

Setup Mode

Table 5.3 MENU1 and MENU2 Items and Options (Cont.)

NOTES:

- Underlined options are the factory defaults.
- Asterisks show items and options that differ for the IBM XL24 and Epson LQ-2500/LQ-2550 emulations. See the end of this table for the meanings.

MENU1 and MENU2 Items	Options	Description
 (continued)	SWIS-UM SWIS-IM SWIS-UB OCR-B DOWNLD#	<p>Swiss 721 Normal, Proportional Swiss 721 Italic, Proportional Swiss 721 Bold, Proportional OCR-B, 12cpi</p> <p>Font 0 or font 1 in the printer's download RAM</p> <p>See Appendix F for font examples.</p>
<QUALITY>	<p><u>LETTER</u></p> <p>REPORT</p> <p>DRAFT</p> <p>HI-DRFT</p>	<p>Select the print quality that meets your needs most of the time.</p> <p>Letter print quality. Provides the highest resolution. This is the slowest print speed. Invalid for the compressed font.</p> <p>Report print quality. Provides lower resolution than letter quality at twice the speed. If you want only the double speed regardless of fonts, use the correspondence font because its quality is higher than report.</p> <p>Regular draft print quality. Provides lower resolution than report quality at three times letter speed.</p> <p>High-speed draft print quality. Provides lower resolution than draft quality at 3.3 times letter speed.</p>

Table 5.3 MENU1 and MENU2 Items and Options (Cont.)

NOTES:

- Underlined options are the factory defaults.
- Asterisks show items and options that differ for the IBM XL24 and Epson LQ-2500/LQ-2550 emulations. See the end of this table for the meanings.

MENU1 and MENU2 Items	Options	Description
<PITCH>	## CPI	2.5, 3, 5, 6, <u>10</u> , 12, 15, 17, 18, or 20 cpi (characters per horizontal inch)
	PROP SP	Proportional spacing (1/12 inch for a space)
<LINE SP>	## LPI	1, 2, 3, 4, 5, <u>6</u> , 7, or 8 lpi (lines per vertical inch)
		<p>6 lpi 3 lpi (double spacing)</p> <p>ABCD ABCD</p> <p>ABCD</p> <p>ABCD ABCD</p> <p>ABCD</p> <p>ABCD ABCD</p> <p>ABCD</p>
<CHAR-W>	<u>NORMAL</u>	If necessary, also change the pitch when 2 TIMES or 4 TIMES is selected. Standard character width ABCD
	2 TIMES	Double character width ABCD
	4 TIMES (*1)	Quadruple character width ABCD

Setup Mode

Table 5.3 MENU1 and MENU2 Items and Options (Cont.)

NOTES:

- Underlined options are the factory defaults.
- Asterisks show items and options that differ for the IBM XL24 and Epson LQ-2500/LQ-2550 emulations. See the end of this table for the meanings.

MENU1 and MENU2 Items	Options	Description
<CHAR-H>		If necessary, also change the line spacing when 2 TIMES or 4 TIMES is selected.
	<u>NORMAL</u>	Standard character height ABCD abcd
	2 TIMES	Double character height ABCD abcd
	4 TIMES (*1)	Quadruple character height ABCD abcd
<ATTRIB>		Selects an attribute to add emphasis to your documents. Only one attribute may be selected at a time.
	<u>NONE</u>	Standard characters (no attributes)
	ITALICS	<i>Italic printing</i>
	CONDNSD (*1)	Condensed printing
	SHADOW	Double printing with a slight horizontal offset
BOLD	Double printing at the same position	

Table 5.3 MENU1 and MENU2 Items and Options (Cont.)

NOTES:

- Underlined options are the factory defaults.
- Asterisks show items and options that differ for the IBM XL24 and Epson LQ-2500/LQ-2550 emulations. See the end of this table for the meanings.

MENU1 and MENU2 Items	Options	Description
<PAGE LG>	## IN	<p>Specifies the length of the page in inches.</p> <p><i>For DPL24C PLUS and IBM XL24 emulations:</i> 3.0, 3.5, 4.0, 5.0, 5.5, 6.0, 7.0, 8.0, 8.5, <u>11.0</u> (letter size), 11.6 (A4 size), 12.0, 14.0, or 18.0 inches</p> <p><i>For Epson LQ-2500/LQ-2550 emulation:</i> 4.0, 4.5, 5.0, ..., <u>11.0</u>, 11.5, ..., 22.0 inches</p>
<COLOR>	<p><u>AUTOSEL</u></p> <p>BLACK YELLOW MAGENTA CYAN</p>	<p><i>Available only for color printers. This item does not print if you have a monochrome printer.</i></p> <p>Automatic color selection. Specifies color using your software. Seven colors can be specified: black, yellow, red, blue, violet, orange, and green.</p> <p>Black } Yellow } Software specifications Red } become invalid. Blue }</p>

Table 5.3 MENU1 and MENU2 Items and Options (Cont.)

NOTES:

- Underlined options are the factory defaults.
- Asterisks show items and options that differ for the IBM XL24 and Epson LQ-2500/LQ-2550 emulations. See the end of this table for the meanings.

MENU1 and MENU2 Items	Options	Description
<LFT-END>	##COLM	<p>Specifies the starting column of the left margin. The left margin equals the number of columns specified by <LFT-END> plus your software-specified left margin.</p> <p>Column <u>1</u>, 2, 3, ..., 41</p> 
<TOP-MRG>	##LINE	<p>Specifies the top margin in lines. To set <TOP-MRG> to 1 inch when line spacing equals 6 lpi, select 7 lines.</p> <p><i>The total size of your top margin is the sum of these three settings: top-of-form, <TOP-MRG> setting, and the software-specified top margin.</i></p> <p>If you are using software to specify the top margin, you should use the default (1 line) for <TOP-MRG>.</p> <p><u>1</u>, 2, 3, 4, 5, 6, 7, 8, 9, or 10 lines</p> 

Table 5.3 MENU1 and MENU2 Items and Options (Cont.)

NOTES:

- Underlined options are the factory defaults.
- Asterisks show items and options that differ for the IBM XL24 and Epson LQ-2500/LQ-2550 emulations. See the end of this table for the meanings.

MENU1 and MENU2 Items	Options	Description
<LANGUGE>		<p>Selects a language. Appendix E shows the character sets for each language.</p> <p>Two-pass means that diacritical marks are printed separately from their letters that are printed without any reduction.</p> <p>The first listing is common to all emulations. Options specific to each emulation are skipped. See the subsequent listings (*3) and(*4).</p>
	USA	American English (Same as code page 437)
	UK	British English
	GERMAN	German
	SWEDISH	Swedish
	<u>PAGE437</u>	Code page 437
	PAGE850	Code page 850
	PAGE860	Code page 860
	PAGE863	Code page 863
	PAGE865	Code page 865
	ECMA94	ECMA 94
	ISO8859	ISO 8859-1
	PG852	Code page 852
	PG852-T	Code page 852 two-pass
	PG855	Code page 855
	PG866	Code page 866
HUNGARY	Hungarian	
HUNG-T	Hungarian two-pass	
SLOV	Slovenian	
SLOV-T	Slovenian two-pass	

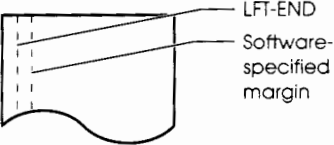
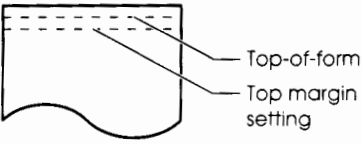
Setup Mode

Table 5.3 MENU1 and MENU2 Items and Options (Cont.)

NOTES:

- Underlined options are the factory defaults.
- Asterisks show items and options that differ for the IBM XL24 and Epson LQ-2500/LQ-2550 emulations. See the end of this table for the meanings.

MENU1 and MENU2 Items	Options	Description	
<LANGUGE> (continued)	POLISH	Polish	
	POLSH-T	Polish two-pass	
	MAZOWIA	Mazowian	
	MAZOW-T	Mazowian two-pass	
	LATIN7	Latin 7	
	LATIN2	Latin 2	
	LATIN2-T	Latin 2 two-pass	
	KAMENIC	Kamenicky	
	KAMEN-T	Kamenicky two-pass	
	TURKY	Turkish	
	TURKY-T	Turkish two-pass	
	CYRILIC	Cyrillic	
	IBM437	IBM 437	
	IBM851	IBM 851	
	ELOT928	ELOT 928	
	PG-DHN	Code page DHN	
	LATIN-P	Latin Polish	
	ISO-LTN	ISO Latin	
	(*3)		
	FRENCH	French	
ITALIAN	Italian		
SPANISH	Spanish		
DANISH1	Danish I		
DANISH2	Danish II		
FINNISH	Finnish		
NORWEGN	Norwegian		
(*4)			
DANISH1	Danish I		
ITALIAN	Italian I		
SPANSH1	Spanish I		
SPANSH2	Spanish II		
JAPAN	Japanese		
NORWEGN	Norwegian		
LATIN A	Latin American		
FRENCH	French I		
DANISH2	Danish II		

Table 5.3 MENU1 and MENU2 Items and Options (Cont.)

NOTES:

- Underlined options are the factory defaults.
- Asterisks show items and options that differ for the IBM XL24 and Epson LQ-2500/LQ-2550 emulations. See the end of this table for the meanings.

MENU1 and MENU2 Items	Options	Description
<CHR-SET>	SET 1 <u>SET 2</u>	IBM character set 1 IBM character set 2 If a download (soft) font is used, the character set for that font overrides the <CHR-SET> setting.
	(*4) <u>ITALIC</u> GRAPHIC	Italic characters available Graphics characters (ruled lines) available
<AGM> (*2)	<u>OFF</u> ON	Specifies that Alternate Graphics Mode (AGM) is off. The base of line spacing is 1/72 or 1/216 of an inch. Specifies that Alternate Graphics Mode (AGM) is on. The base of line spacing is 1/60 or 1/180 of an inch.
<PRF-SKP>	 SKIP <u>NO-SKIP</u>	For continuous forms, specifies whether an inch is skipped over the perforation. If you are not using software to specify a bottom margin, select SKIP when using thicker multi-part forms. One inch is skipped over the perforation. The perforation is not skipped. Printing continues in the bottom margin of the page.

Table 5.3 MENU1 and MENU2 Items and Options (Cont.)

NOTES:

- Underlined options are the factory defaults.
- Asterisks show items and options that differ for the IBM XL24 and Epson LQ-2500/LQ-2550 emulations. See the end of this table for the meanings.

MENU1 and MENU2 Items	Options	Description
<WIDTH>	<u>13.6 IN</u> 11.0 IN 8.0 IN	13.6-inch page width (for 136-column printer only) 11-inch page width (default for 110-column printer) 8-inch page width
<ZEROFNT> (*3)	<u>NO-SLSH</u> SLASH	Specifies whether to print the number zero with a slash. This is useful for distinguishing the capital letter "O" from the number "0". Invalid for some soft fonts. 0 ø
<DC3-CDE>	<u>ENABLE</u> DISABLE	Enables the DC1 and DC3 codes. Any data received between DC3 and the next DC1 is ignored. Disables the DC1 and DC3 codes. These codes are then ignored.
<CR-CODE>	<u>CR ONLY</u> CR & LF	No line feed is added to a carriage return.  A line feed is added to each carriage return. 

Table 5.3 MENU1 and MENU2 Items and Options (Cont.)

NOTES:

- Underlined options are the factory defaults.
- Asterisks show items and options that differ for the IBM XL24 and Epson LQ-2500/LQ-2550 emulations. See the end of this table for the meanings.

MENU1 and MENU2 Items	Options	Description
<LF-CODE> (*3)	LF ONLY	No carriage return is added to a line feed. 
	<u>LF & CR</u>	A carriage return is added to each line feed. 
<RGHTEND>	<u>WRAP</u>	End-of-line wrap. Causes a carriage return plus a line feed. 
	OVR-PRT	Characters are overprinted at the end of a line. 
<==END==>		Indicates the end of MENU1 items. Press MENU SELECT to print the first item, <EMULATE>. Press FONT SELECT to print the previous item, <RGHTEND>. Press ONLINE to reprint the <<FUNCTION>> menu.

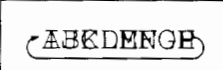
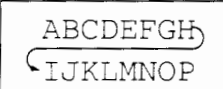
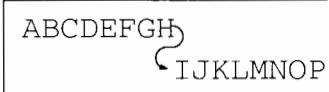
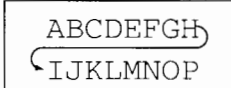
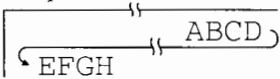
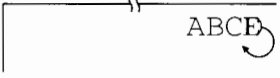
- *1 Unavailable for the IBM XL24 emulation
- *2 Available *only* for the IBM XL24 emulation
- *3 Unavailable for the Epson LQ-2500/LQ-2550 emulations
- *4 Available *only* for the Epson LQ-2500/LQ-2550 emulations

Procedure

To change the options assigned to MENU1 or MENU2, make sure that continuous forms paper is loaded. Then take the following steps.

1. Enter setup mode.

Press MENU SELECT and FONT SELECT simultaneously. Wait for the printer to stop printing. The <<FUNCTION>> menu is printed as follows:

```
<< FUNCTION >>
SAVE&END  MENU1  MENU2  HARDWRE  LIST                DEFAULT  SELP-TST  HEX-DUMP  V-ALMNT  TOP-ADJ
```

2. Select the MENU1 or MENU2 function.

Repeatedly press LF/FF to position the red cursor beneath either the MENU1 or MENU2 function. Press MENU SELECT to select the function and print the <EMULATE> options as shown below.

```
< EMULATE >      DPL24C+  IBMXL24                LQ2500  LQ2550
```

3. Select an emulation.

Repeatedly press LF/FF to position the cursor beneath the emulation you require. Then do one of the following:

- Press MENU SELECT to select the emulation and print the next MENU1 or MENU2 item. As shown in Table 5.3, this is the item.
- Press FONT SELECT to select the emulation and print <==END==>. Press FONT SELECT again to print the last MENU1 or MENU2 item. As shown in Table 5.3, this is the <RGHTEND> item. Using FONT SELECT is convenient

when the options you need to change are near the end of the list of items.

NOTE

Whenever you select a new emulation, all MENU1 or MENU2 options are reset to the factory defaults for that emulation.

4. Change the other MENU1 or MENU2 options if required.

Press LF/FF to move the cursor to the option you want to select. Press MENU SELECT to select the option and print the next item listed in Table 5.3. Press FONT SELECT to select the option and print the previous item.

5. Exit MENU1 or MENU2.

Press ONLINE to exit the selected function and reprint the <<FUNCTION>> menu.

6. Do one of the following:

- **Select another function.**
- **Exit setup mode, saving your changes.**

For details about other functions, see the other sections in this chapter. To exit setup mode and save your changes, make sure the red cursor is positioned beneath SAVE&END, and then press MENU SELECT.

Resetting MENU1 and MENU2

To reset the factory defaults for both MENU1 and MENU2, select the DEFAULT function. For a detailed procedure, see the section **Resetting Defaults** later in this chapter. The hardware and top-of-form options are not reset.

CHANGING HARDWARE OPTIONS

The HARDWRE function defines the printer's hardware conditions. The following options must be set properly for the printer to function correctly with your system hardware:

- Serial interface options (for serial interface model only)
- Type of cut sheet feeder (if installed)

The HARDWRE items and options are listed in Table 5.4. Items are listed in the order in which they are printed. The procedure for changing the hardware options follows Table 5.4.

Table 5.4 HARDWRE Items and Options

NOTE: Underlined options are the factory defaults.

HARDWRE Items	Options	Description
<PPR-OUT>		Specifies how the printer responds when you run out of paper.
	<u>CNTO</u> NLY	The printer detects paper-out only for continuous forms. Printing stops and the PAPER OUT indicator turns red.
	DETECT	The printer detects paper-out for both continuous forms and single sheets. Printing stops and the PAPER OUT indicator turns red.
	IGNORE	The printer ignores paper-out for both continuous forms and single sheets. Printing continues until no more data remains. No PAPER OUT warning appears.
		NOTE: For cut sheet feeders, printing stops and the PAPER OUT indicator turns red, regardless of the PPR-OUT setting.

Table 5.4 HARDWARE Items and Options (Cont.)

NOTE: Underlined options are the factory defaults.

HARDWARE Items	Options	Description
<PRT-DIR>	<u>BI-DIR</u> UNI-DIR	Bidirectional printing. Unidirectional printing is useful for precision printing, such as vertical lines in tables. Printing is slower than bidirectional printing.
<BUZZER>	<u>ON</u> OFF	Turns the printer's status buzzer on or off. Buzzer on. This is the recommended setting. The printer beeps to indicate paper-out or various other conditions. Buzzer off
<WORD-LG>	<u>8 BIT</u> 7 BIT	To determine the required word length, refer to your computer documentation. Select 8-BIT when you print bit image graphics. 8-bit word length. Used by most computers. 7-bit word length (MSB = 0)

Table 5.4 HARDWRE Items and Options (Cont.)

NOTE: Underlined options are the factory defaults.

HARDWRE Items	Options	Description
<BUFFER>		Print buffer Download buffer
	256BYTE	256 bytes 31.75K bytes
	2KBYTE	2K bytes 30K bytes
	<u>8KBYTE</u>	8K bytes 24K bytes
	24KBYTE	24K bytes 8K bytes
<p>NOTE: For IBMXL24 emulation, the print buffer is fixed to 256 bytes regardless of the setting for this item. For LQ-2500/LQ-2550 emulation with 24KBYTE selected, a download error occurs.</p>		
<FEEDER>		Tells the printer whether a cut sheet feeder is installed.
	<u>REAR</u>	No cut sheet feeder is installed.
	SINGLE	A single bin cut sheet feeder is installed.
	DOUBLE	A double bin cut sheet feeder is installed.
<p>Serial Interface Items. The following <FORMAT> to <DUPLEX> items are printed only when your printer has a serial interface. Be sure that the options selected on the printer are the same as the options selected using your computer's operating system or your software. Refer to the documentation provided for your computer and software.</p>		

Table 5.4 HARDWARE Items and Options (Cont.)

NOTE: Underlined options are the factory defaults.

HARDWARE Items	Options	Description		
		No. of data bits	Parity bit	No. of stop bits
<FORMAT>	<u>8NONE 1</u>	8	None	1
	8NONE 2	8	None	2
	8EVEN 1	8	Even	1
	8 ODD 1	8	Odd	1
	7EVEN 1	7	Even	1
	7 ODD 1	7	Odd	1
	7MARK 1	7	Mark	1
	7SPACE1	7	Space	1
	7EVEN 2	7	Even	2
	7 ODD 2	7	Odd	2
		The data format includes a start bit. The mark parity bit is always logical 1. The space parity bit is always logical 0.		
<BAUD-RT>	150	The baud rate is in bps (bits per second). Select the same baud rate as your computer or modem.		
	300			
	600			
	1200			
	4800			
	<u>9600</u>			
	19200			

Table 5.4 HARDWRE Items and Options (Cont.)

NOTE: Underlined options are the factory defaults.

HARDWRE Items	Options	Description
<PROTOCL>		Indicates data transmission protocol.
	<u>XON/XOF</u> DTR	The DC1 and DC3 codes are used. The Data Terminal Ready signal is used.
	REV-CHL	The Reverse Channel signal is used.
	ETX/ACK	The ETX and ACK codes are used.
<DSR>	<u>IGNORE</u>	DSR is ignored by the printer.
	DETECT	DSR is detected by the printer.
<DUPLEX>	<u>FULL</u>	Simultaneous data transmission occurs in opposite directions.
	HALF	Data transmission occurs in either direction, but not simultaneously.
<TEAROFF>	<u>MANUAL</u>	Automatic tearoff feed is invalid, and must be done manually.
	AUTO	Automatic tearoff feed is valid for continuous forms only. Tearoff feed can also be done manually.
The following <TEARPOS> and <TEAR-EN> items are printed when TEAROFF:AUTO is specified for the above <TEAROFF> item.		

Table 5.4 HARDWRE Items and Options (Cont.)

NOTE: Underlined options are the factory defaults.

HARDWRE Items	Options	Description
<TEARPOS>	<p><u>VISIBLE</u></p> <p>ALWAYS</p>	<p>Specifies that forms are fed to the next perforation after printing the last data. The printer assumes that forms are set at the top-of-form position when the host has stopped data transfer. The printer performs tearoff feed without adding a form feed when the host has stopped data transfer.</p> <p>Specifies that the printer stops after printing the last data. The printer performs tearoff feed after adding a form feed when the host has stopped data transfer.</p> <p>Note: For both settings, tearoff positioning fails if the page length selected does not match actual perforation spacing.</p>
<TEAR-EN>	<p>0 sec</p> <p><u>1 sec</u></p> <p>2 sec</p> <p>4 sec</p> <p>6 sec</p>	<p>The offset time is from when the host stops data transfer to when the printer performs automatic tearoff feed. If the printer receives data again within the offset time, the printer does not perform automatic tearoff feed.</p> <p>In some application programs, data transfer may stop temporarily due to internal processing. This setting can prevent undesired tearoff feed by waiting for up to six seconds each time data transfer stops.</p>

Table 5.4 HARDWRE Items and Options (Cont.)

NOTE: Underlined options are the factory defaults.

HARDWRE Items	Options	Description
<==END==>	—	Indicates the end of the HARDWRE item list. Press MENU SELECT to print the first item, which is <PPR-OUT>. Press FONT SELECT to print the previous item. Press ONLINE to reprint the <<FUNCTION>> menu.

Procedure

To change the printer’s hardware options, make sure that continuous forms are loaded. Then take the following steps.

1. Enter setup mode.

Press MENU SELECT and FONT SELECT simultaneously. Wait for the printer to stop printing and check that the <<FUNCTION>> menu is printed as shown below.

<< FUNCTION >>	
SAVE&END MENU1 MENU2 <u>HARDWRE</u> LIST	DEFAULT SELF-TST HEX-DUMP V-ALMNT TOP-ADJ

2. Select the HARDWRE function.

Repeatedly press LF/FF to position the red cursor beneath HARDWRE. Press MENU SELECT to select HARDWRE and print the first item and its options as shown below.

< PPR-OUT >	<u>ONTONLY</u> DETECT	IGNORE
-------------	-----------------------	--------

3. Select an option for the selected item.

Press LF/FF to move the cursor to the option you require. Press MENU SELECT to select the option and print the next item.

NOTE

To print the previous item, press FONT SELECT.

4. Repeat step 3 until all required options are changed.**5. Exit the HARDWRE function.**

Press ONLINE to exit the HARDWRE function and reprint the <<FUNCTION>> menu.

6. Do one of the following:

- **Select another function.**
- **Exit setup mode, saving your changes.**

For details on other functions, see the other sections in this chapter. To exit setup mode and save your changes, make sure that the red cursor is positioned beneath SAVE&END, then press MENU SELECT.

CHANGING TOP-OF-FORM

The top edge of your paper is the *physical* top of the page. The *logical* top of the page, as “understood” by the printer when loading paper, is called its top-of-form setting. The TOF-ADJ function tells the printer where it should establish top-of-form. Printing starts at the position obtained by adding the following:

- Top-of-form setting
- Top margin specified by your software
- Printer’s TOP-MRG (top margin) setting

The printer’s top-of-form setting can be either 1/6 of an inch (4.2 mm) or 1 inch (25.4 mm). You can also fine-adjust this setting. The factory default is 1 inch.

The TOF-ADJ items and options are listed in Table 5.5. Items are listed in the order they are printed. The procedure for changing top-of-form follows Table 5.5.

CAUTION

You should not use the no-margin setting since the print head mask may snag the top edge of the paper. You can use no-margin setting while your software prepares a proper margin.

Table 5.5 TOF-ADJ Items and Options

NOTE: Underlined options are the factory defaults.

TOF-ADJ Items	Options	Description
<ORIGIN>	1/6INCH	Sets top-of-form to 1/6 of an inch from the top of the physical page. This setting is recommended when your top margin is software-specified.
	<u>1 INCH</u>	Sets top-of-form to 1 inch from the top of the physical page. This setting is recommended if your top margin is not software-specified.
<FINEADJ>		Fine-adjusts top-of-form in increments of 1/60 of an inch (0.42 mm).
	-7/60IN,..., -1/60IN	Decreases top-of-form slightly.
	<u>0</u> +1/60IN,..., +8/60IN	Increases top-of-form slightly.
<==END==>	—	Indicates the end of the TOF-ADJ item list. Press MENU SELECT to print the first item, which is <ORIGIN>. Press FONT SELECT to print the last item, which is <FINEADJ>. Press ONLINE to reprint the <<FUNCTION>> menu.

Procedure

To change the top-of-form setting, make sure that continuous forms paper is loaded. Then take the following steps.

1. Enter setup mode.

Press MENU SELECT and FONT SELECT simultaneously. Wait for the printer to stop printing and check that the <<FUNCTION>> menu is printed as shown below.

```
<<FUNCTION>>
SAVE&END MENU1  MENU2  HARDWARE LIST                DEFAULT SELF-TST HEX-DUMP V-ALMNT  TOP-ADJ
```

2. Select the TOF-ADJ function.

Repeatedly press LF/FF to position the red cursor beneath TOF-ADJ. Press MENU SELECT to select TOF-ADJ and print the <ORIGIN> options as shown below.

```
<ORIGIN >      1/6INCH  1 INCH
```

3. Select 1/6 inch or 1 inch.

Press LF/FF to move the cursor to either 1/6 inch (4.2 mm) or 1 inch (25.4 mm). Press MENU SELECT to select the option. The <FINEADJ> item is then printed. If top-of-form must be fine-adjusted, do so now. Otherwise, go to step 4.

4. Exit the TOF-ADJ function.

Press ONLINE to exit the TOF-ADJ function and reprint the <<FUNCTION>> menu.

5. Exit setup mode, saving the top-of-form setting.

Make sure that the red cursor is positioned beneath SAVE&END, then press MENU SELECT.

6. Check the top-of-form setting.

Load a sheet of paper and print a sample page using your software. If necessary, re-enter setup mode and fine-adjust top-of-form by changing the <FINEADJ> option.

EXITING AND SAVING

There are two different methods to exit setup mode and save any changes you made. Briefly, these methods are:

- To exit setup mode immediately, select the SAVE&END function.
- To print the self-test before exiting setup mode, select the SELF-TST function. Then exit setup mode by pressing ONLINE.

With either method, any settings you changed while in setup mode are saved as the printer's new power-on defaults. The new defaults remain active until you change them again.

NOTE

The only way to exit setup mode without saving your changes is to turn off the printer. When you turn the printer back on, its previous default settings become active.

Procedure

To exit setup mode and save your changes using SELF-TST, see the section **Printing the Self-Test** later in this chapter. To exit setup mode and save your changes using SAVE&END, follow these steps.

1. Print the <<FUNCTION>> menu.

The <<FUNCTION>> menu should be the last printed line on the page. If it is not printed, press ONLINE to print it. If you are using the SELF-TST or HEX-DUMP function, press LF/FF instead of ONLINE to print it. The <<FUNCTION>> menu is shown below.

```
<<FUNCTION>>
SAVE&END MENU1  MENU2  HARDWRE LIST                DEFAULT SELF-TST HEX-DUMP V-ALMNT TOP-ADJ
```

2. Select the SAVE&END function.

Make sure that the red cursor is positioned beneath SAVE&END. Press MENU SELECT to select SAVE&END. The printer exits setup mode and returns online (the ONLINE indicator turns green). Any changes you made while in setup mode are saved.

RESETTING DEFAULTS

This section describes how to reset the printer's power-on defaults, all of the factory defaults, or the factory defaults only for MENU1 and MENU2.

Resetting Power-On Defaults

Power-on defaults are those settings saved in the printer's permanent memory. The defaults are active whenever you turn the printer on. The easiest way to reset the power-on defaults is to turn the printer off and then on. This is useful if you have made changes in setup mode that you do not want to save.

Resetting Factory Defaults

Factory defaults are those settings preselected at the factory. For a list of the printer's factory defaults, see the section **Printing a List of Selected Options** earlier in this chapter. To reset the factory defaults for all functions, follow these steps.

1. Turn off the printer.
2. While pressing both the MENU SELECT and FONT SELECT buttons, turn on the printer. Continue to press them until the printer beeps.

The factory defaults are now reset.

Resetting Factory Defaults in MENU1 and MENU2

Factory defaults for MENU1 and MENU2 are listed in Table 5.3. To reset the factory defaults in MENU1 and MENU2 only, use the following procedure. The printer's hardware and top-of-form options are not reset.

1. Enter setup mode.

Press MENU SELECT and FONT SELECT simultaneously. Wait for the printer to stop printing and check that the <<FUNCTION>> menu is printed as shown below.

```

<< FUNCTION >>
SAVE&END MENU1  MENU2  HARDWRE LIST                DEFAULT SELF-TST HEX-DUMP V-ALMNT TOP-ADJ
    
```

2. Select the DEFAULT function.

Repeatedly press LF/FF to position the red cursor beneath DEFAULT. Press MENU SELECT to select DEFAULT and re-print the <<FUNCTION>> menu. The default values in MENU1 and MENU2 are now reset.

3. Do one of the following:

- **Select new options for MENU1 or MENU2.**
- **Exit setup mode, saving the factory defaults.**

See the section **Changing MENU1 and MENU2 Options**. To exit setup mode and save the new defaults, make sure that the red cursor is positioned beneath SAVE&END, then press MENU SELECT.

USING THE DIAGNOSTIC FUNCTIONS

This section describes how to use the following diagnostic functions:

- SELF-TST
- HEX-DUMP
- V-ALMNT

These functions are helpful for checking print quality and diagnosing printer problems. HEX-DUMP is also useful to programmers.

Printing the Self-Test

The SELF-TST function prints test pages to check how the printer operates independent of your computer. The self-test does not check the interface between the computer and the printer.

The self-test prints the printer's firmware version, its resident emulations, and all of the characters available in the currently selected character set. For color printers with a color ribbon, printing occurs in seven colors. If the DPL24C PLUS emulation is selected for MENU1, the self-test is printed using the settings currently assigned to MENU1. For example, if Prestige Elite 12 and italics are selected, the self-test will print using Prestige Elite 12 and italics. This is a convenient way to see how printing from MENU1 will look.

Procedure

This procedure assumes that you are in setup mode. To print the self-test, make sure that continuous forms paper is loaded into the printer. Then follow these steps.

1. Print the <<FUNCTION>> menu.

The <<FUNCTION>> menu should be the last printed line on the page. If it is not printed, press ONLINE to print it. If you are using the HEX-DUMP function, press LF/FF instead of ONLINE to print it. The <<FUNCTION>> menu is shown below.

```

<< FUNCTION >>
SAVE&END MENU1  MENU2  HARDWRE LIST                DEFAULT SELF-TST HEX-DUMP V-ALMNT TOP-ADJ
    
```

2. Select the SELF-TST function.

Repeatedly press LF/FF to position the red cursor beneath SELF-TST, and then press MENU SELECT. The printer selects SELF-TST and starts printing. A short help menu is printed at the top of the page, followed by the self-test. Note that the printer *does not go online* during self-test printing.

3. Examine the self-test page.

To pause self-test printing, press MENU SELECT or FONT SELECT. A sample self-test page is shown in Chapter 2. To resume self-test printing, press MENU SELECT or FONT SELECT again.

4. Exit the SELF-TST function.

To exit the SELF-TST function, do one of the following:

- To exit SELF-TST and remain in setup mode, press LF/FF. The <<FUNCTION>> menu is then reprinted.
- To exit SELF-TST and return online, press ONLINE. The printer permanently saves any changes you made while in setup mode and returns online.

Another way to start self-test is to turn off the printer, and then press the LF/FF button while turning the printer back on. As described in Chapter 2, this method is convenient when you first set up the printer.

Printing Hex Dumps

The HEX-DUMP function prints data and commands in hexadecimal characters and abbreviated control codes. The character set used for printing is IBM character set 2 (see Appendix E). This is useful for checking whether your computer is sending the correct commands to the printer and whether the printer is executing the commands correctly. It is also useful for debugging software programs.

Procedure

To print hex dumps, make sure that continuous forms paper is loaded into the printer. Then follow these steps.

1. Enter setup mode.

Press MENU SELECT and FONT SELECT simultaneously. Wait for the printer to stop printing and check that the <<FUNCTION>> menu is printed as shown below.

```

<< FUNCTION >>
SAVE&END MENU1  MENU2  HARDWR  LIST                DEFAULT  SELF-TST  HEX-DUMP  V-ALMNT  TOP-ADJ
    
```

2. Select the HEX-DUMP function.

Repeatedly press LF/FF to position the red cursor beneath HEX-DUMP, then press MENU SELECT to select HEX-DUMP. The printer goes *online* and prints a header and a short help menu.

3. Print the hex dump.

To start hex dump printing, send your file or program to the printer. The printer goes online and prints the hex dump.

Press MENU SELECT or FONT SELECT to pause hex dump printing. To resume hex dump printing, press the button again.

```

<<FUNCTION>>
SAVE&END MENU1 MENU2 HARDWRE LIST          DEFAULT SELF-TST HEX-DUMP Y-ALHMT TOP-ADJ

*** Hex dump printing ***

BUTTON      ACTION
<ONLINE>    Exit to normal mode
< LF/FF >   Return to <<FUNCTION>> menu
< MENU >    Pause/resume printing
< FONT >    Pause/resume printing

0  1  2  3  4  5  6  7  8  9  A  B  C  D  E  F  0123456789ABCDEF
48 65 78 20 64 75 6D 70 20 70 72 69 6E 74 69 6E  Hex dump printin
67 2E 0D 0A 0D 0A 1B 70 01 41 42 43 44 45 46 47  g.[]\|_`~@ABCDEF
48 49 4A 4B 4C 4D 4E 4F 50 51 52 53 54 55 56 57  HIJKLMNQPQRSTUVWXYZ
58 59 5A 0D 0A 61 62 63 64 65 66 67 68 69 6A 6B  XYZ[]\abcdefghijklmnop
6C 6D 6E 6F 70 71 72 73 74 75 76 77 78 79 7A 0D  lmnopqrstuvwxyz[]
0A 31 32 33 34 35 36 37 38 39 0D 0A 1B 40      []123456789[]\|_`~@
    
```

Sample hex dump

NOTE

When hex dump printing stops, the printer remains online in setup mode (the ONLINE indicator is green). To print another hex dump, send another file to the printer.

Setup Mode

4. Exit the HEX-DUMP function.

To exit the HEX-DUMP function, do one of the following:

- To exit HEX-DUMP and remain in setup mode, press LF/FF. The <<FUNCTION>> menu is then reprinted. For details on other functions, see other sections in this chapter.
- To exit HEX-DUMP and return to online normal mode, press ONLINE. If you press ONLINE while the hex dump is printing, printing continues but the printer switches from hexadecimal format to standard characters.

An alternate way to print hex dumps is as follows:

- Turn off the printer.
- While simultaneously pressing the ONLINE and LF/FF buttons, turn the printer back on. Continue pressing the buttons until the printer beeps.
- Send your file or program to the printer. Hex dump printing then starts.

Checking Vertical Print Alignment

The V-ALMNT function corrects the vertical character displacement that sometimes occurs with bidirectional printing. Characters printed from left to right become misaligned with the characters printed from right to left. An example of vertical displacement follows:

```
{ This example shows how printing looks  
{ when characters are vertically  
{ misaligned. Note that the left  
{ margin is not straight.
```

If you notice misaligned printing, use the following procedure to check and correct the vertical print alignment.

Procedure

Make sure that continuous forms paper is loaded into the printer. If possible, use forms at least 356 mm (14 inches) wide to avoid printing on the platen. However, you can also use forms of letter or A4 size by setting the WIDTH option in MENU1 to 8 inches. See the section **Changing MENU1 and MENU2 Options** for details. Follow these steps to check and correct vertical print alignment.

1. Enter setup mode.

Press MENU SELECT and FONT SELECT simultaneously. Wait for the printer to stop printing and check that the <<FUNCTION>> menu is printed as shown below.

```
<<FUNCTION>>
SAVE&END MENU1  MENU2  HARDWRE LIST          DEFAULT  SELP-TST  HEX-DUMP  V-ALMNT  TOP-ADJ
```

2. Select the V-ALMNT function.

Repeatedly press LF/FF to position the red cursor beneath V-ALMNT, then press MENU SELECT to select the V-ALMNT function. The printer starts printing rows of parallel bars using letter quality speed.

3. Adjust the vertical print alignment at letter quality speed.

Look at the parallel bars. If the bars are aligned (not jagged), go to step 4. If the bars are offset to the left, repeatedly press FONT SELECT until the bars are aligned. If the bars are offset to the right, repeatedly press MENU SELECT until the bars are aligned. See the following figure for details.



Bars offset to the left



Bars offset to the right

4. Adjust the vertical print alignment at correspondence speed.

Press LF/FF to switch from letter speed to correspondence speed.

Look at the parallel bars. If the bars are aligned (not jagged), go to step 5. If the bars are offset to the left, repeatedly press FONT SELECT until the bars are aligned. If the bars are offset to the right, repeatedly press MENU SELECT until the bars are aligned.

5. Adjust the vertical print alignment at draft speed.

Press LF/FF to switch from correspondence speed to draft speed.

Look at the parallel bars. If the bars are aligned (not jagged), go to step 6. If the bars are offset to the left, repeatedly press FONT SELECT until the bars are aligned. If the bars are offset to the right, repeatedly press MENU SELECT until the bars are aligned.

6. Exit the V-ALMNT function.

Press ONLINE to exit the V-ALMNT function and save the new vertical alignment settings. The printer exits setup mode and returns online.

NOTE

To exit the V-ALMNT function, you must exit setup mode.

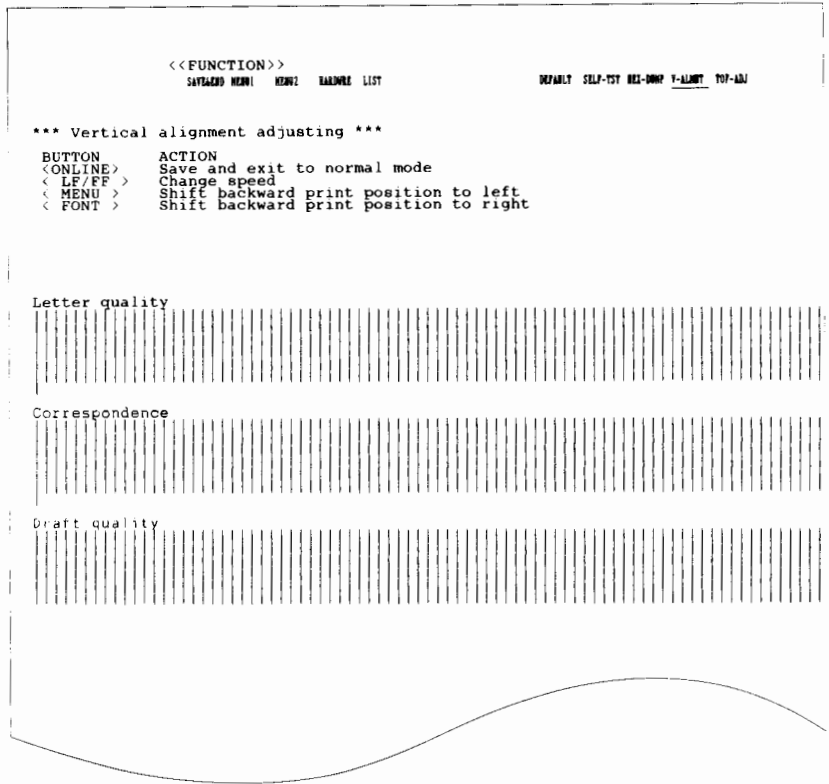

Correct vertical print alignment

SETUP MODE REFERENCE

The flowchart in this section shows how setup mode is organized for Fujitsu DPL24C PLUS emulation. Following the flowchart, differences are listed for the IBM Proprinter XL24 and Epson LQ-2500/LQ-2550 emulations.

DPL24C PLUS ORGANIZATION

* Indicates factory default

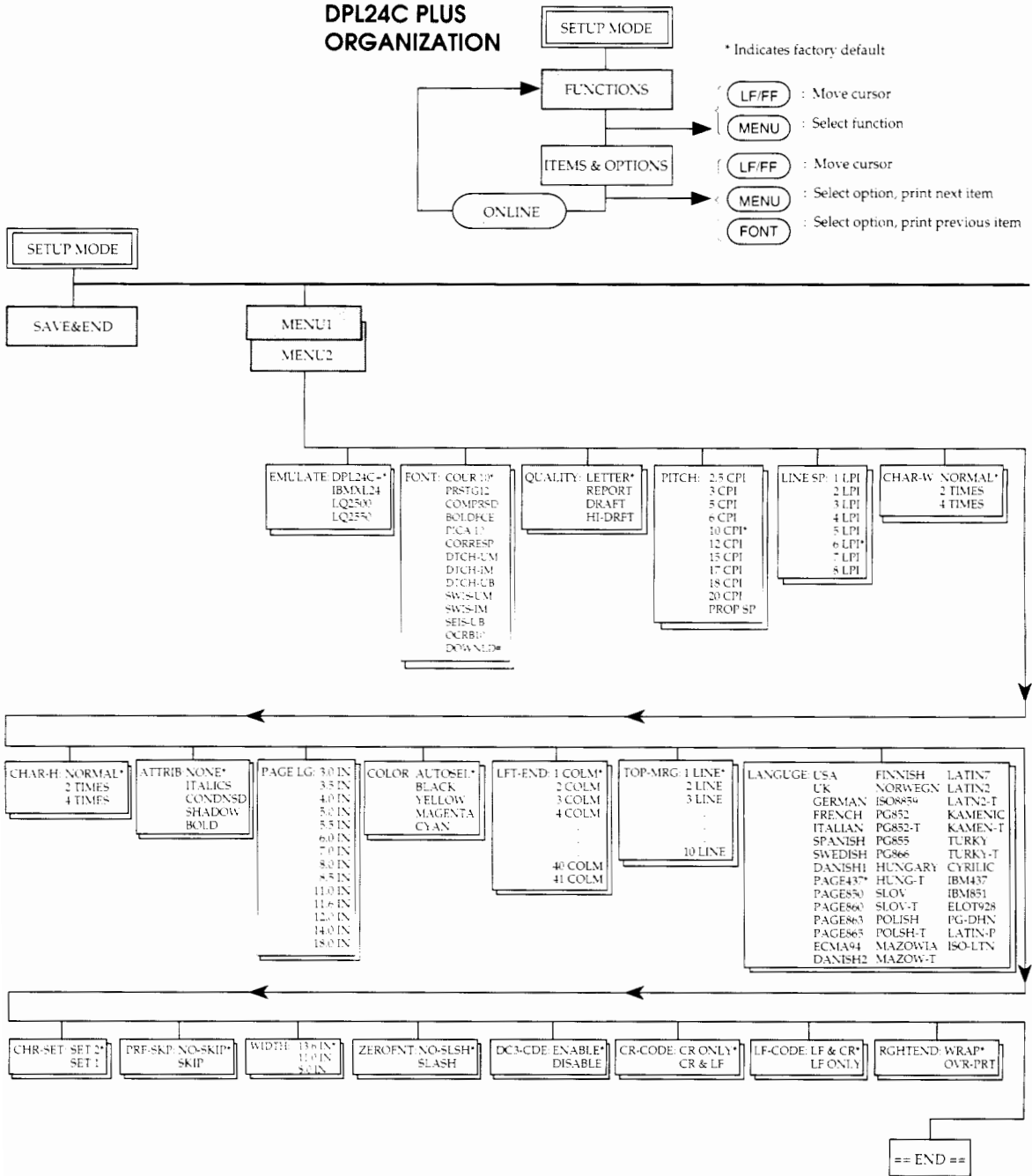

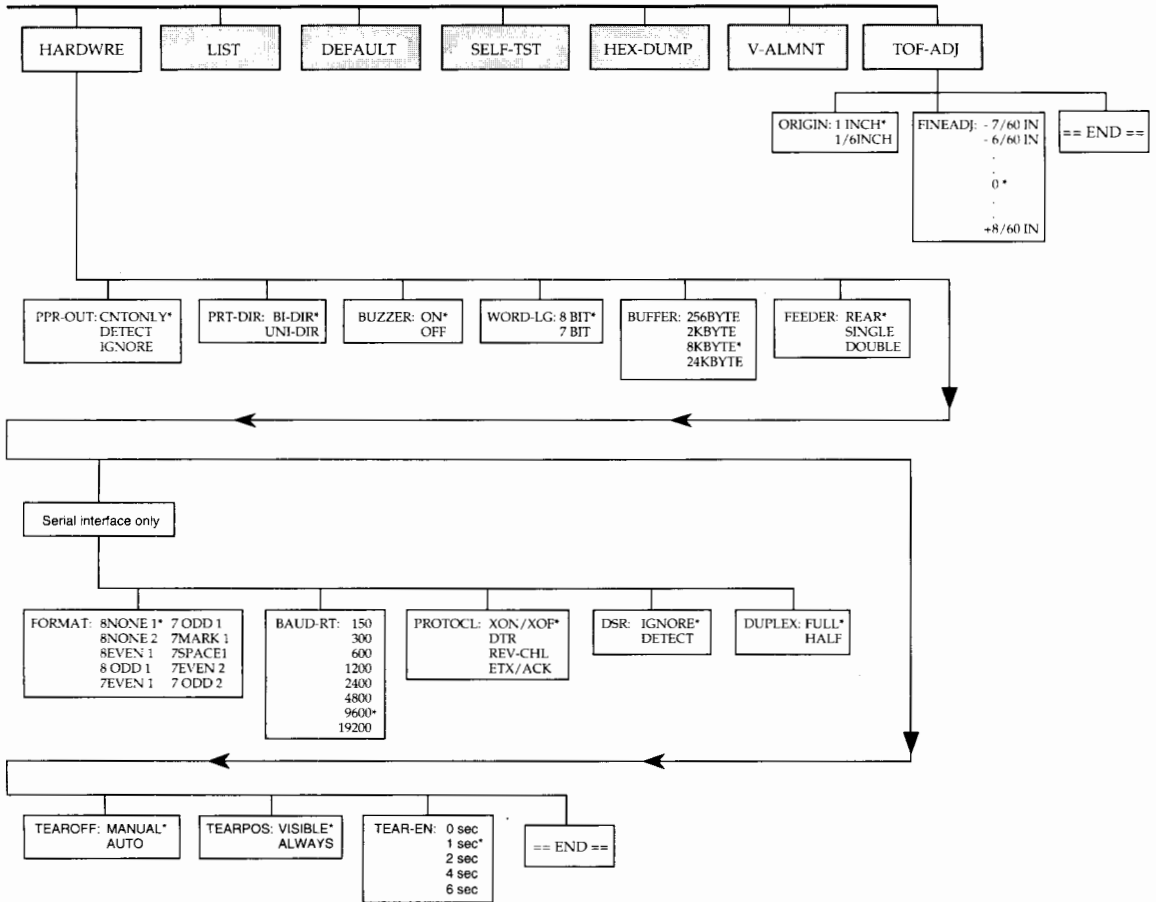

Differences for IBM Proprinter XL24 Emulation

In the IBM Proprinter XL24 emulation, MENU1 and MENU2 differ from the DPL24C PLUS emulation in the following ways:

- The following options are different:

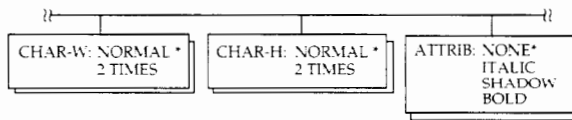

- The AGM item is provided:

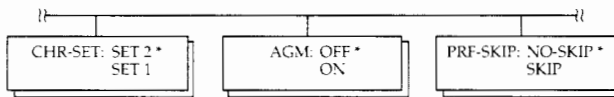

Differences for Epson LQ-2500/LQ-2550 Emulation

In the Epson LQ-2500/LQ-2550 emulations, MENU1 and MENU2 differ from the DPL24C PLUS emulation in the following ways:

- The ZEROFONT and LF-CODE items are not defined.
- The following options are different:

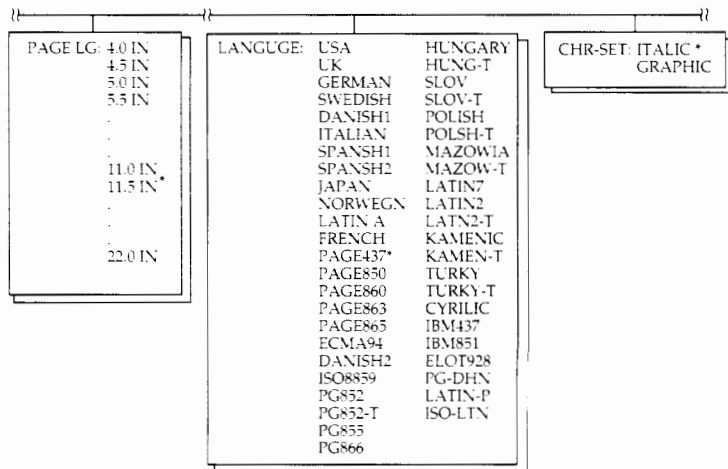

ONLINE SETUP

The procedure explained in the preceding sections is called offline setup mode. Online setup mode, described below, helps facilitate the tedious task of setting up printer features one by one from the control panel while printing and checking the desired options on paper.

In online setup mode, printer features are set via the computer, not the printer control panel. Note that control panel buttons other than LF/FF, TEAR OFF, and LOAD/UNLOAD cannot be used.

To use online setup mode, issue the printer command ESC e ONLINE (*data*) EXIT in any emulation; [ONLINE to enter online setup mode; (*data*) to select setup conditions such as functions, items, and options to be defined; and EXIT to exit the mode].

Setup data is sent from the computer in one of three ways:

- Enter setup data directly from the computer keyboard before starting your job. With MS-DOS, hold down the Ctrl key and type P; data entered from the keyboard is sent directly to the printer. When data entry is completed, hold down the Ctrl key again and type P. This is useful when changing just a few settings.
- Use an editor to prepare a setup data file and send the file to the printer using a command before starting your job. With MS-DOS, use the COPY command. This is useful when using settings repeatedly.
- Write a program that enables interactive entry of setup data on the CRT screen. This is the most useful of the three. Check with your dealer about currently available programs.

For details, refer to the programmer's manual for each emulation.

MAINTENANCE

Your printer requires very little care. Occasional cleaning and replacement of the ribbon cartridge are all that is required.

Lubrication of the printer is not usually necessary. If the print head carriage does not move smoothly back and forth, clean the printer using the procedures in this chapter. If the problem continues, contact your dealer to determine whether lubrication might be needed.

CLEANING

The front and top covers of the printer help protect it from dust, dirt, and other contaminants. Paper produces small particles that accumulate inside the printer. This section explains how to clean and vacuum the printer and how to clean the platen and paper bail rollers.

Cleaning and Vacuuming the Printer

WARNING

To avoid any possibility of injury, turn off the power to both the printer and the computer, and unplug the printer before cleaning.

Use the following procedure to clean and vacuum the printer as required.

1. Remove any paper from the printer. Make sure that the power is off, and then disconnect the printer power cord.
2. Using a soft vacuum brush, vacuum the exterior of the printer. Be sure to vacuum the air vents at the sides and rear of the printer. Also vacuum the cut sheet stand or feeder.
3. Use a soft, damp cloth to wipe the exterior of the printer, including the front and top covers. A mild detergent may be used.

CAUTION

Do not use solvents, kerosine, or abrasive cleaning materials that may damage the printer.

4. Open the front and top covers of the printer and remove the ribbon cartridge. Using a soft vacuum brush, gently vacuum the platen, print head carriage, and surrounding areas. You can easily move the print head left and right with the power off. Be careful not to press too hard on the flat ribbon cable extending from the print head carriage (see the following figure).

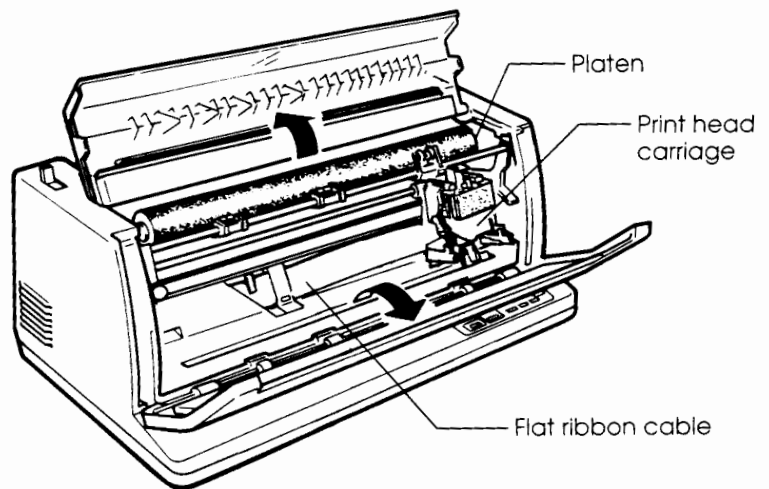

Printer interior

5. Re-install the ribbon cartridge. Close the front and top covers.
6. Raise the cut sheet stand. Vacuum the rear forms tractors and surrounding areas.

Cleaning the Platen and Paper Bail Rollers

To remove excess ink from the platen and paper bail rollers, clean them about once a month. Obtain the platen cleaner recommended by your supplier and follow these steps.

1. Apply a small amount of platen cleaner to a soft cloth. Avoid spilling platen cleaner inside the printer.

CAUTION

Do not use alcohol to clean the platen. Alcohol may cause the rubber to harden.

2. Place the cloth against the platen and manually rotate the platen knob.
3. To dry the platen, place a dry cloth against it while rotating the platen knob.
4. Gently wipe the paper bail rollers using the cloth containing the platen cleaner. Dry the rollers with a dry cloth.

REPLACING THE RIBBON CARTRIDGE

A color printer can use either a color or black ribbon cartridge. A monochrome printer *requires* a black ribbon cartridge. Appendix A lists order numbers for ribbon cartridges.

To replace the ribbon cartridge:

1. Turn off the printer.
2. Open the top and front covers of the printer. For easy access to the print head carriage, slide it about three quarters of the way to the right side of the platen.

CAUTION

The print head may be hot if you have been printing recently.

3. Move the paper thickness lever to position ③ or ④.

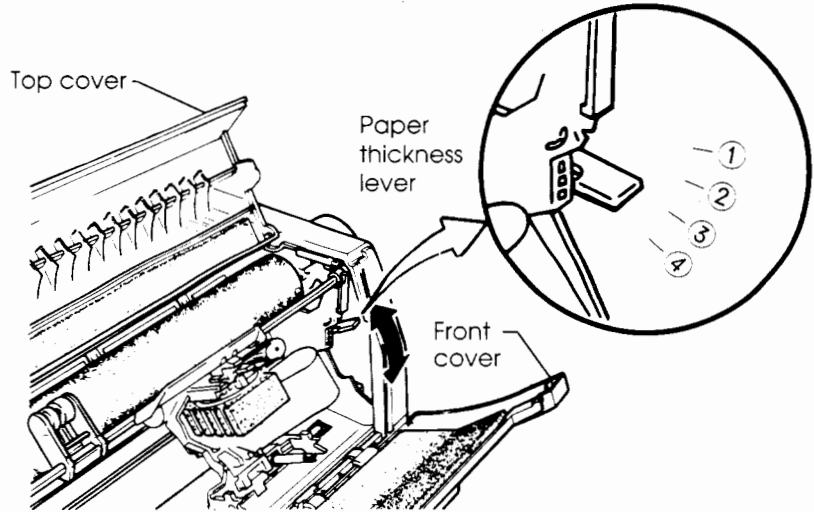

Paper thickness lever

4. To remove the ribbon cartridge, press in the ribbon release levers on either side of the cartridge and carefully lift the cartridge out of the printer.

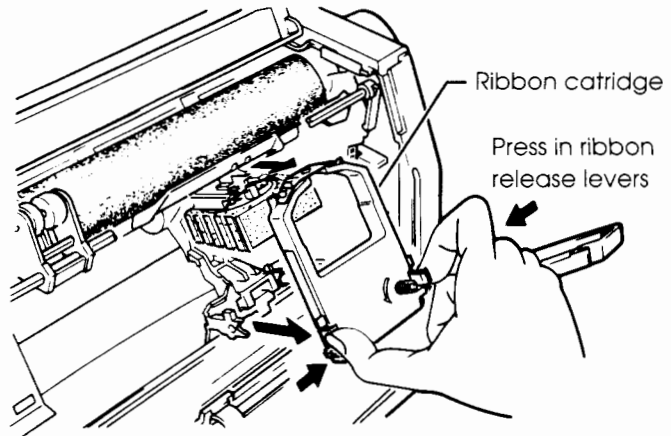

Removing the ribbon cartridge

5. Remove the new ribbon cartridge from its package. If the ribbon is color, remove the red stopper releasing the ribbon feed knob (see the following figure). Turn the ribbon feed knob counterclockwise to be sure that it feeds properly.

NOTE

If using a black ribbon, do not remove the small strip of plastic covering the ribbon. This is the *ribbon mask*, used to protect the ribbon.

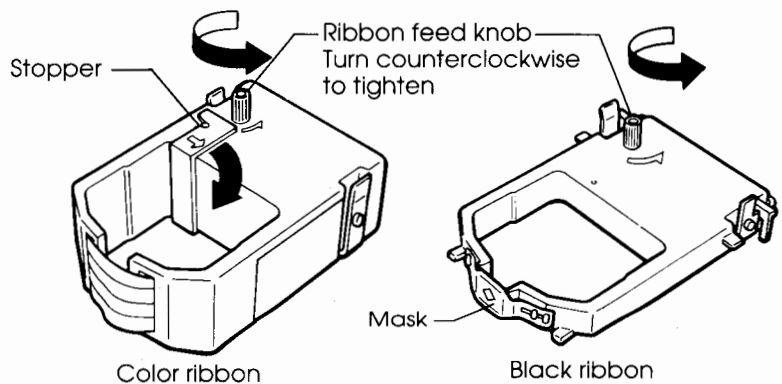
**Preparing the new ribbon cartridge**

6. Referring to the following figure, place the two mounting pins (on the sides of the ribbon release levers) onto the ribbon support studs inside the printer. Rotate the cartridge so that the ribbon falls between the nose of the print head and the plastic print guide.

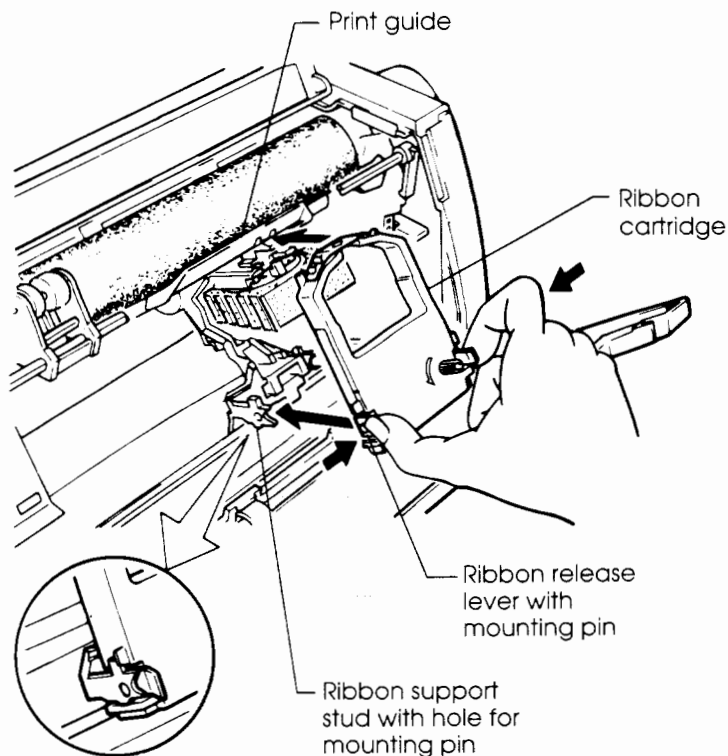

Installing the new ribbon cartridge

7. Press in the ribbon release levers until the mounting pins snap into the holes on the ribbon support studs. Gently pull on the cartridge to verify that the pins are securely installed in the holes.
8. Turn the ribbon feed knob counterclockwise to tighten the ribbon.
9. Move the paper thickness lever (inside the right side of the printer) back to its original position. For single sheet printing, the correct position is ① (uppermost). Table 3.2 in Chapter 3 gives other paper thickness lever settings.
10. Close the top and front covers of the printer.

REPLACING THE PRINT HEAD

The print head is very easy to replace.

To remove the print head:

1. Turn off the printer.
2. Open the top and front covers of the printer.
3. Press the right end of the wire down to release it from the hook at the right. Then raise the wire to release it from the other hook.
4. Remove the print head from the connector on the carriage as shown in the figure.

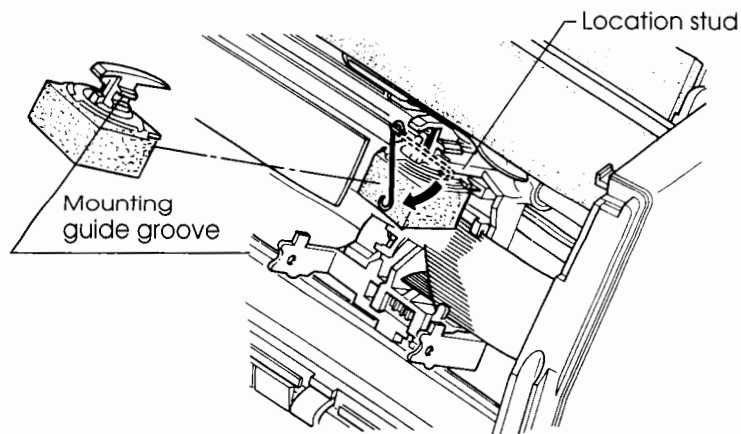
***Replacing the print head***

To install the print head:

1. Carefully fit the mounting guide grooves of the print head onto the location studs on the carriage.
2. Push the print head into the connector, and hook the wire into its place.

PROBLEM SOLVING

Your printer is extremely reliable, but occasional problems may occur. You can solve many of these problems yourself, using this chapter. For problems you cannot resolve, contact your dealer for assistance. This chapter is organized as follows:

- Problems and solutions
- Diagnostic functions
- Getting help

PROBLEMS AND SOLUTIONS

The tables in this section list common printer problems and their solutions. The following types of problems are listed:

- Printing problems
- Paper handling problems
- Operational problems
- Printer failures

Printing Problems

Poor print quality or other printing problems are often caused by incorrect printer setup or incorrect software settings. A gradual decrease in print quality usually indicates a worn ribbon. Table 7.1 lists common printing problems and their solutions.

Table 7.1 Printing Problems and Solutions

Problems	Solutions
<p>Printing is too light or too dark.</p>	<p>Make sure that the ribbon cartridge is properly installed and that the ribbon feeds smoothly.</p> <p>Make sure that the paper thickness lever is set for the thickness of your paper. See Table 3.2 in Chapter 3.</p> <p>The ribbon may be worn. Replace the ribbon.</p>
<p>Stains or smudges appear on the page.</p>	<p>Make sure that the paper thickness lever is set for the thickness of your paper. See Table 3.2 in Chapter 3.</p> <p>The ribbon may be worn. Replace the ribbon.</p> <p>Check to see whether the tip of the print head is dirty. Clean it with a soft cloth.</p>
<p>The page is blank.</p>	<p>Make sure that the ribbon cartridge is properly installed.</p>
<p>Printing is erratic or the wrong characters are printed. Many "?" characters are printed.</p>	<p>Make sure that the interface cable is securely connected to both the printer and computer.</p> <p>Make sure that the printer emulation selected in your software is the same as the emulation selected on the printer. See the section Selecting an Emulation in Chapter 2.</p> <p>If you are using an RS-232C serial interface, make sure that the serial settings required by your software or computer are the same as the settings on the printer. See the section Changing Hardware Options in Chapter 5.</p>

Table 7.1 Printing Problems and Solutions (Cont.)

Problems	Solutions
Printing is vertically misaligned (jagged).	Use the printer's V-ALMNT function to check the vertical print alignment. If necessary, adjust the print alignment. See the section Using the Diagnostic Functions in Chapter 5.
The top margin is wrong.	<p>The top margin is the sum of the top-of-form setting, the software-specified top margin, and the printer's TOP-MRG setting. Check the following:</p> <ul style="list-style-type: none"> • Make sure that the top-of-form setting is correct. The possible defaults are 25.4 mm (1 inch) and 4.2 mm (1/6 inch). See the section Changing Top-of-Form in Chapter 5. • Check the software-specified top margin. Refer to your software documentation. • Check the printer's TOP-MRG setting. See the section Changing MENU1 and MENU2 Options in Chapter 5.
Lines are double spaced instead of single spaced.	<p>Check the line spacing setting in your software.</p> <p>Change the CR-CODE setting in the printer's setup mode to CR ONLY. See the section Changing MENU1 and MENU2 Options in Chapter 5.</p>
The printer keeps printing on the same line.	Change the CR-CODE setting in the printer's setup mode to CR & LF. See the section Changing MENU1 and MENU2 Options in Chapter 5.
The next print line starts where the previous line ended instead of at the left margin.	Change the LF-CODE setting in the printer's setup mode to LF & CR. See the section Changing MENU1 and MENU2 Options in Chapter 5.

Problem Solving

Paper Handling Problems

Table 7.2 lists common paper handling problems and their solutions. See Chapter 3 for detailed procedures on loading and using paper.

Table 7.2 Paper Handling Problems and Solutions

Problems	Solutions
<p>Paper cannot be loaded.</p>	<p>Make sure that the paper select lever is set correctly. Move the lever forward for continuous forms and backward for single sheets.</p> <p>Make sure that your paper covers the paper-out sensor (the groove on the left side of the platen).</p> <p>If you are using a cut sheet feeder, make sure that the bin lever (on the left side of the feeder) is set down to the "CLOSED" position.</p> <p>If you are using a cut sheet feeder, make sure that FEEDER was set correctly in setup mode. Specify SINGLE for a single bin feeder or DOUBLE for a double bin feeder. See the section Changing Hardware Options in Chapter 5.</p>
<p>Paper jams while loading.</p>	<p>Turn off the printer and remove the jammed paper. Remove any obstructions from the paper path.</p> <p>Make sure that the paper thickness lever is set for the thickness of your paper. See Table 3.2 in Chapter 3.</p> <p>If using a cut sheet feeder, make sure that the bin lever (on the left side of the feeder) is set down to the "CLOSED" position.</p> <p>Make sure that the paper is not folded, creased, or torn.</p> <p>Re-load the paper.</p>

Table 7.2 Paper Handling Problems and Solutions (Cont.)

Problems	Solutions
<p>Paper jams while printing.</p>	<p>Turn off the printer and remove the jammed paper. Remove any obstructions from the paper path.</p> <p>Make sure that the paper thickness lever is set for the thickness of your paper. See Table 3.2 in Chapter 3.</p> <p>For continuous forms, make sure that the incoming and outgoing paper stacks are correctly placed. Paper should feed in a straight line.</p> <p>If you are using a cut sheet feeder, make sure that the bin lever (on the left side of the feeder) is set down to the "CLOSED" position.</p> <p>Re-load the paper.</p>
<p>Paper slips off the forms tractors or the perforated holes of the paper are broken during printing.</p>	<p>Make sure that the forms tractors are positioned for the width of your paper and that the perforated holes of the paper fit directly over the tractor sprockets.</p>

Operational Problems

Table 7.3 lists common operational problems and their solutions. If you cannot resolve a problem, contact your dealer.

Table 7.3 Operational Problems and Solutions

Problems	Solutions
<p>The power does not turn on.</p>	<p>Make sure that the "1" on the printer's power switch is toggled up.</p> <p>Make sure that the power cord is securely connected to both the printer and the outlet. Make sure that the power outlet is functional.</p> <p>Turn the power off. Wait 30 seconds and turn the printer on again. If the printer still has no power, contact your dealer.</p>
<p>The printer is on, but it will not print.</p>	<p>Make sure that the printer is online.</p> <p>Make sure that the interface cable is securely connected to both the printer and the computer.</p> <p>Check whether the red PAPER OUT indicator is lit. If so, load paper.</p> <p>Run the printer's self-test (see Chapter 5). If the self-test executes normally, the problem is caused by the interface, the computer, incorrect printer settings, or incorrect software settings.</p> <p>Make sure that the printer emulation selected in your software is the same as the emulation selected on the printer. See the section Selecting an Emulation in Chapter 2.</p>

Table 7.3 Operational Problems and Solutions (Cont.)

Problems	Solutions
The printer is on, but it will not print (continued).	If you are using an RS-232C serial interface, make sure that the serial settings required by your software or computer are the same as the settings on the printer. See the section Changing Hardware Options in Chapter 5.
The cut sheet feeder does not operate.	Make sure that the cut sheet feeder is firmly mounted on the printer. Make sure that FEEDER was set correctly in setup mode. Specify SINGLE for a single bin feeder or DOUBLE for a double bin feeder. See the section Changing Hardware Options in Chapter 5.

Printer Failures

If the printer hardware is defective, you usually cannot solve this type of problem. On detecting a fatal alarm, the printer does the following:

- Stops printing
- Beeps four times
- Turns the ONLINE indicator off
- Blinks the PAPER OUT indicator (with a FONT indicator lit indicating the alarm type).

Table 7.4 Printer Failures

Failure name	FONT indicator lit
Power alarm	COUR10
Left end sensor alarm	PICA10
Overload printing alarm	DRAFT10
RAM alarm	DRAFT12

Turn the printer off and back on, then run the same job to check if the alarm was transient. If it occurs again, contact your dealer.

DIAGNOSTIC FUNCTIONS

The printer's diagnostic functions are SELF-TST, HEX-DUMP, and V-ALMNT.

- SELF-TST tells you whether the printer hardware is functioning correctly. If the printer hardware is functional, any problems you are having are probably caused by incorrect printer settings, incorrect software settings, the interface, or the computer.
- HEX-DUMP allows you to determine whether the computer is sending the correct commands to the printer, and whether the printer is executing the commands correctly. This function is useful to programmers or others who understand how to interpret hex dumps.
- V-ALMNT allows you to check and, if necessary, correct the printer's vertical print alignment.

For details on using these functions, all of which are available in the printer's setup mode, see Chapter 5.

GETTING HELP

If you are not able to correct a problem using this chapter, contact your dealer for assistance. Be prepared to provide the following information:

- Your printer's model number, serial number, and date of manufacture. Look for this information on the nameplate at the rear of the printer.
- Description of the problem
- Type of interface you are using
- Names of your software packages
- List of the printer's default settings. To print the default settings, see Chapter 5.

INSTALLING OPTIONS

By installing options, you can expand the capabilities of your printer. Options available for the printer include:

- Single bin cut sheet feeder
- Double bin adapter for cut sheet feeder
- Color kit

All options can be purchased from your dealer and installed by you. This chapter describes what to do after installing each option. See Appendix A for order numbers.

INSTALLING A CUT SHEET FEEDER

A cut sheet feeder allows you to automatically print on single sheets without inserting the sheets one by one. A double bin adapter is also available.

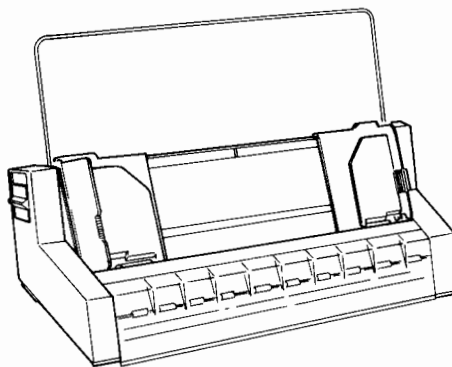

Single bin cut sheet feeder

To mount a cut sheet feeder on your printer, refer to the manual shipped with the feeder. After the feeder is mounted, you must enter the printer's setup mode and specify either SINGLE or DOUBLE as the feeder type. Otherwise, the feeder will not work. One of the following three options must be selected, depending on the cut sheet feeder(s) in use.

- REAR: No cut sheet feeder
- SINGLE: Single-bin cut sheet feeder
- DOUBLE: Double-bin cut sheet feeder

To enter setup mode and specify the feeder type, see the section **Changing Hardware Options** in Chapter 5.

For details on using your cut sheet feeder, see Chapter 3.

INSTALLING THE COLOR KIT

You can turn your monochrome printer into a color printer by installing a color kit on the print head carriage. The ribbon shift unit of the color kit is shown below.

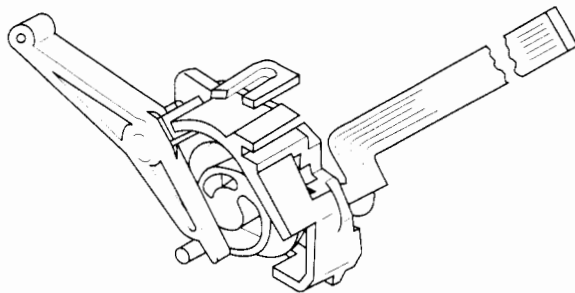

Color kit (ribbon shift unit)

To install the color kit on your printer, refer to the instructions shipped with the kit. After the color kit is installed, you must enter setup mode and make sure AUTOSEL is specified as the color selection.

Otherwise, the printer does not follow the color command from your software. The following five options are provided. AUTOSEL remains selected unless you have changed the color selection.

AUTOSEL: Seven colors printed by command
BLACK: Black printed regardless of commands
YELLOW: Yellow printed regardless of commands
MAGENTA: Red printed regardless of commands
CYAN: Blue printed regardless of commands

To enter setup mode and specify the color selection, see the section **Changing MENU1 and MENU2 Options** in Chapter 5.

Use the self-test function to check color printing without the color command from your software. See the section **Testing the Printer (Offline)** in Chapter 2.

SUPPLIES, OPTIONS, AND PUBLICATIONS

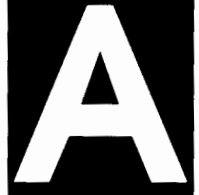

This appendix lists the supplies, options, and programmer's manuals available for the printer. Contact your dealer for information on ordering any of these items.

SUPPLIES

Supplies	Order Numbers
Ribbon cartridges	
Black ribbon	D30L-9001-0939
Color ribbon	D30L-9001-0938
Print head	D86B-1171-C202

OPTIONS

Options	Order Numbers	Description
Cut sheet feeder For 110-column printers	ASF300-FJ1101	Single bin feeder
	ASF300-FJ1111	Double bin adapter (mounted on single bin feeder)
	ASF300-FJ0901	Single bin feeder (not capable of mounting double bin adapter)
For 136-column printers	ASF300-FJ1201	Single bin feeder
	ASF300-FJ1211	Double bin adapter (mounted on single bin feeder)
Color kit	D05B-9010-C113	Color ribbon included
Fujitsu Creative Faces™	D05B-9011-C100	Font-scaling software utility for Microsoft® Windows™; giving text smooth, well formed characters, virtually free of jagged edges.

PUBLICATIONS

Publications	Order Numbers
Programmer's Manual (DPL24C PLUS Command Set)	B-69518
Programmer's Manual (IBM XL24 Emulation)	B-69519
Programmer's Manual (Epson LQ-2500/LQ-2550 Emulation)	B-69520

PRINTER AND PAPER SPECIFICATIONS

This appendix lists physical, functional, and performance specifications for the printer. It also gives detailed specifications for paper.

PHYSICAL SPECIFICATIONS

Dimensions	110 columns	136 columns
	Height: 193 mm (7.6 in.)	193 mm (7.6 in.)
	Width: 460 mm (18.1 in.)	526 mm (20.7 in.)
	Depth: 250 mm (9.8 in.)	250 mm (9.8 in.)
Weight	110 columns	136 columns
	5.8 kg (12.8 lb)	6.3 kg (13.9 lb)
AC power requirements		
M3382A/M3383A:	100 to 120 VAC $\pm 10\%$; 50/60 Hz $+2\%$, -4%	
M3382B/M3383B:	220 to 240 VAC -10% , $+6\%$; 50/60 Hz $+2\%$, -4%	
Power consumption	65 W when printing Hs in letter quality Maximum 130 W	
Heat generation	Maximum 60 kcal/h	
Interface	Centronics parallel or RS-232C serial	
Data buffer size	256, 2K, 8K, or 24K bytes	
Download buffer	Maximum 31.75K bytes (32K minus data buffer size)	
Operating environment	5 to 38°C (41 to 100°F) 30% to 80% RH (no condensation) Wet bulb temperature, less than 29°C (84°F)	
Storage environment	-25 to 60°C (-13 to 140°F) 10% to 90% RH (no condensation)	
Acoustic noise	Average 52 dBA when printing in letter quality ISO DP7779 (Bystander Position Front)	

FUNCTIONAL SPECIFICATIONS

Print method	Impact dot matrix with a 0.2 mm, 24-wire head	
Print direction	Bidirectional, unidirectional, or logic seeking	
Character cell	Horizontal x vertical	
Letter (10 cpi):	36 x 24 dots	
Letter (12 cpi):	30 x 24 dots	
Report:	18 x 24 dots	
Draft:	12 x 24 dots	
High-speed draft:	9 x 24 dots	
Paper handling	<ul style="list-style-type: none"> Standard: Friction-feed platen (cut sheets) Rear push tractors (continuous forms) Paper loading by LOAD/UNLOAD button Paper positioning at the tear-off edge by TEAR OFF button Parking of continuous forms while using cut sheets Optional: Single-bin cut sheet feeder Double-bin adapter 	
Paper type	<ul style="list-style-type: none"> 1- to 4-part side-glued or paper-stapled fan-folded continuous forms or label sheets with sprocket holes 1- to 4-part top-glued single sheets and envelopes 	
Paper size	110 columns	136 columns
Continuous	Width: 102-330 mm (4-13 in.)	102-406 mm (4-16 in.)
	Length: 102 mm (4 in.) or greater	Same as left
Cut sheets	Width: 102-330 mm (4-13 in.)	102-420 mm (4-16.5 in.)
	Length: 76-364 mm (3-14.3 in.)	Same as left
Paper thickness	<ul style="list-style-type: none"> Up to 0.3 mm (0.012 inch) (For envelopes, the maximum thickness at the multi-layer part can be up to 0.5 mm (0.02 inch)). 	
Page length	<ul style="list-style-type: none"> Software Programmable in one line or inch increments in all emulations 	

Control panel Depends upon emulations. Default is 11 inches in all emulations
 DPL24C+/XL24: 3, 3.5, 4, 5, 5.5, 6, 7, 8, 8.5, 11, 11.6, 12, 14, or 18 inches
 LQ-2500/LQ-2550: 4, 4.5, 5, 5.5, ..., 11, 11.5, ..., 22 inches

Number of copies Up to 4, including the original

Command sets (emulations)

Resident Fujitsu DPL24C PLUS
 IBM Proprinter XL24
 Epson LQ-2500/LQ-2550

Character sets

- DPL24C+/XL24:
- IBM PC character sets 1 and 2
 - IBM PS/2 character sets (code pages 437, 850, 852, 855, 860, 863, 865, 866, and DHN) IBM 437 and 851
 ISO 8859-1 and ECMA 94
 Total 37 national character sets
 - Fujitsu character sets (357 characters)
- LQ-2500/LQ-2550:
- Italic character set
 Graphics character sets 1 and 2
 - IBM PS/2 character sets (code pages 437, 850, 852, 855, 860, 863, 865, 866, and DHN) IBM 437 and 851
 ISO 8859-1 and ECMA 94
 Total 39 national character sets

Fonts

Resident Fifteen fonts available
 Letter quality: Courier 10, Pica 10, OCR-B 10, Pesticide Elite 12, Boldface PS, Dutch PS (upright, italic, bold), and Swiss PS (upright, italic, bold)
 Others: Correspondence, Compressed, Draft, and High-speed Draft

Download Available from independent vendors

Line spacing 1, 2, 3, 4, 5, 6, 7, or 8 lines per inch. Programmable in 1/360 inch or various increments for image graphics.

Character pitch 2.5, 3, 5, 6, 10, 12, 15, 17.1, 18, or 20 cpi, or proportional spacing. Programmable in 1/360 inch or various increments for image graphics.

Specifications

Characters per line	110 columns	136 columns
	10 cpi: 110 cpl	136 cpl
	12 cpi: 132 cpl	163 cpl
	15 cpi: 165 cpl	204 cpl
	17.1 cpi: 188 cpl	231 cpl
	18 cpi: 198 cpl	244 cpl
	20 cpi: 220 cpl	272 cpl

cpi: characters per inch, cpl: characters per line

PERFORMANCE SPECIFICATIONS

Print speed	10 cpi	12 cpi
	Letter: 60 cps	72 cps
	Report: 120 cps	144 cps
	Correspondence: 120 cps	144 cps
	Draft: 180 cps	216 cps
	High-speed draft: 200 cps	240 cps

cpi: characters per inch
cps: characters per second

Line feed speed 110 ms per line at 6 lines per inch

Form feed speed 2 inches per second

Ribbon life

Color: Up to 0.2 million characters per color
Black: Up to 3.5 million characters

Certification

Safety:

Model	Applied Regulation	Applied Area
M3382A/M3383A	UL 1950-D3 (for 100-120 VAC)	United States
	CSA C22.2/220 (for 100-120 VAC)	Canada
M3382B/M3383B	TÜV EN 60 950 (for 220-240 VAC)	Germany

RFI regulation:

Model	Applied Regulation	Applied Area
M3382A/M3383A	Class B of FCC Part 15B (for 100 to 120 VAC)	United States

PAPER SPECIFICATIONS

Print Area

This section illustrates the recommended print area for single sheets and continuous forms.

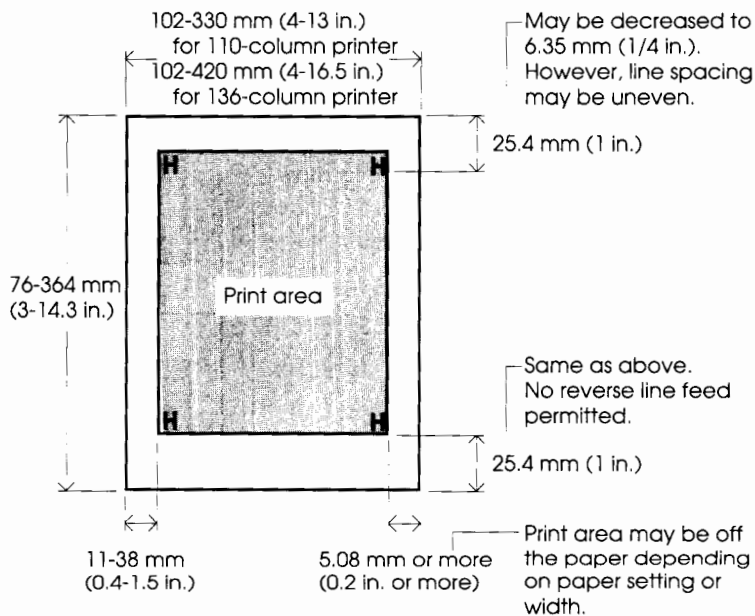

Print area for single sheets

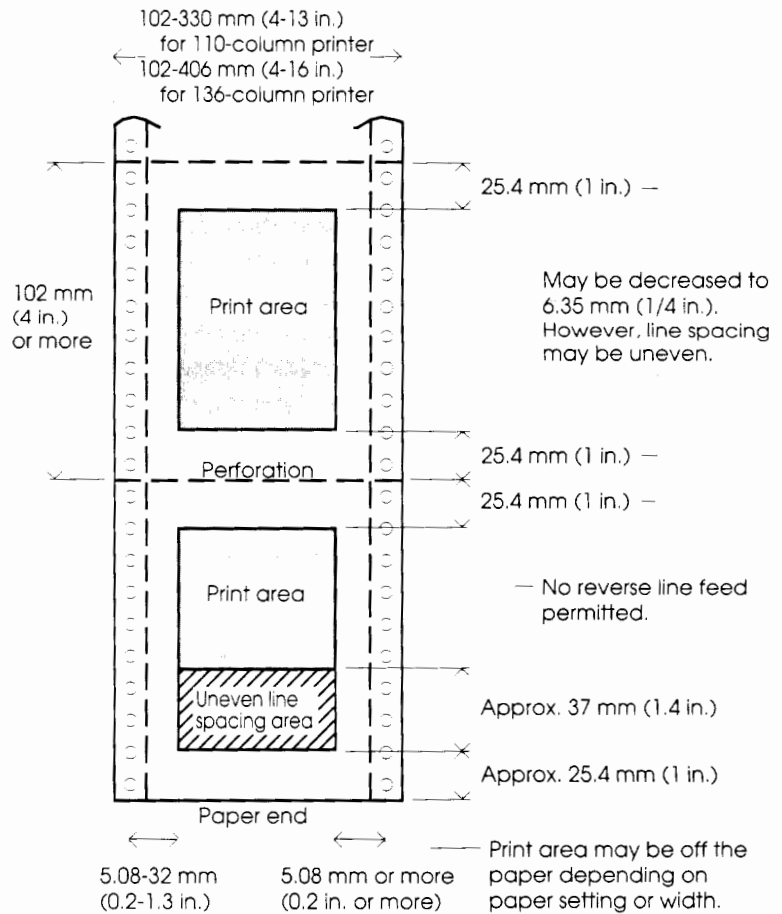

Print area for continuous forms

Paper Thickness

Paper thickness is indicated by the weight of the paper in either grams per square meter (g/m²) or in pounds per bond (lbs/bond). The following table shows the allowable paper thickness for one-part paper or for each sheet of multipart paper. The total thickness must not exceed 0.3 mm (0.012 inch).

For carbonless or carbon-backed paper, the weight may vary, depending upon the paper manufacturer. When using paper of borderline thickness, test the paper before actual use.

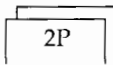
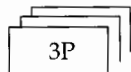
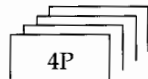
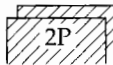
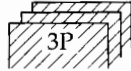
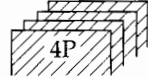
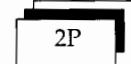
Type of Paper	Part	Thickness
One-part	Single	52-81 g/m ² (45-70 kg or 14-22 lb)
Carbonless  2P  3P  4P	Top	50 -64 g/m ² (43-55 kg or 13-17 lb)
	Bottom	50-81 g/m ² (43-70 kg or 13-22 lb)
	Top	40-50 g/m ² (34-43 kg or 11-13 lb)
	Middle	40-50 g/m ² (34-43 kg or 11-13 lb)
	Bottom	40-64 g/m ² (34-55 kg or 11-17 lb)
	Top	40 g/m ² (34 kg or 11 lb)
Middle	for each part	
Middle		
Bottom		
Carbon-backed  2P  3P  4P	Top	52-64 g/m ² (45-55 kg or 14-17 lb)
	Bottom	52-81 g/m ² (45-70 kg or 14-22 lb)
	Top	40-52 g/m ² (34-45 kg or 11-14 lb)
	Middle	40-52 g/m ² (34-45 kg or 11-14 lb)
	Bottom	40-64 g/m ² (34-55 kg or 11-17 lb)
	Top	40 g/m ² (34 kg or 11 lb)
Middle	for each part	
Middle		
Bottom		
Carbon-interleaved  2P	Top	35-52 g/m ² (30-45 kg or 9-14 lb)
	Carbon	Counted as one sheet
	Bottom	35-64 g/m ² (30-55 kg or 9-17 lb) <i>Avoid using carbon-interleaved single sheets.</i>

kg: Kilogram weight of 1000 sheets of 788 x 1091 mm paper (1.16 g/m²)

lb: Pound weight of 500 sheets of 17 x 22 inch paper (3.76 g/m²)

COMMAND SETS

This appendix lists commands and their parameters.



This printer has four resident command sets:

- Fujitsu DPL24C PLUS (native command set for Fujitsu DL series printers)
- IBM Proprinter XL24
- Epson LQ-2500
- Epson LQ-2550

Separate programmer's manuals are available for these emulations. See Appendix A for order numbers.

Select the same emulation on the printer as for your software. If your software supports more than one emulation, including DPL24C PLUS, select DPL24C PLUS for better performance.

FUJITSU DPL24C PLUS

This section lists the printer commands for the DPL24C PLUS command set that is the native command set of this printer. See the *Programmer's Manual (DPL24C PLUS)* for detailed information on using these commands.

Function	Command
Print Mode Control	
Double-strike (bold) printing on	ESC G
Double-strike (bold) printing off	ESC H
Emphasized (shadow) printing on	ESC E
Emphasized (shadow) printing off	ESC F
Italic printing on	ESC 4
Italic printing off	ESC 5
Select character style and screening	ESC e S (n_1) (n_2)
$n_1 = 0$: Normal	
1: Outline	
2: Shaded	
3: Outline and shaded	
4: Thin outline	
5: Thin shaded	
6: Thin outline and shaded	
$n_2 = 0$: Transparent	
1: Light dot matrix	
2: Heavy dot matrix	
3: Vertical bars	
4: Horizontal bars	
5: Slants	
6: Back slants	
7: Lattice	
One-line double width characters on	SO or ESC SO
One-line double width characters off	DC 4
Double width characters on/off (on: $n = 1$, off: $n = 0$)	ESC W (n)

Function	Command
Double height characters on/off (on: $n = 1$, off: $n = 0$) This command does not adjust the line spacing.	ESC V (n)
Multi width and height printing $n = 0$: Not adjusted 1: Character pitch multiplied 2: Line spacing multiplied 3: Character pitch & line spacing multiplied h_1 : Tens digit of horizontal multiple h_2 : Units digit of horizontal multiple v_1 : Tens digit of vertical multiple v_2 : Units digit of vertical multiple ($0 \leq h_1, h_2$ or $v_1, v_2 \leq 16$)	ESC u (n) (h_1) (h_2) (v_1) (v_2)
Condensed characters on	SI or ESC SI
Condensed characters off	DC2
Subscript or superscript printing on (subscript: $n=1$, superscript: $n=0$)	ESC S (n)
Subscript and superscript printing off	ESC T
Select underline type $n=0$: Single line 1: Bold single line 2: Extremely bold single line 3: Double line 4: Bold double line 5: Extremely bold double line	ESC e U (n)
Underline on/off (on: $n=1$, off: $n=0$)	ESC - (n)
Overline on/off (on: $n=1$, off: $n=0$)	ESC e o (n)

Function	Command
<p>Select printing style</p> <p>This command allows you to combine various printing styles. The value of <i>n</i> is the sum of the values of the styles you want to combine.</p> <p><i>n</i>=0: Pica pitch 1: Elite pitch 4: Condensed 8: Shadow 16: Bold 32: Double width 64: Proportional</p>	ESC ! (<i>n</i>)
<p>Select image overlay type</p> <p>This command allows you to overlay a pattern on characters.</p> <p><i>n</i>=1: Light dot matrix 2: Heavy dot matrix 3: Vertical bars 4: Horizontal bars 5: Slants 6: Back slants 7: Lattice</p>	ESC e I (<i>n</i>)
<p>Image overlay printing on/off (on: <i>n</i>=1, off: <i>n</i>=0)</p>	ESC e L (<i>n</i>)
<p>Horizontal Control</p> <p>Space Backspace Carriage return Elite pitch (12 cpi) Pica pitch (10 cpi) Proportionally spaced characters on/off (on: <i>n</i>=1, off: <i>n</i>=0) Set character pitch to (<i>n</i>-1)/120 inch (1 ≤ <i>n</i> ≤ 127) Set character pitch to <i>n</i>/180 inch (0 ≤ <i>n</i> ≤ 255)</p>	<p>SP BS CR ESC M ESC P ESC p (<i>n</i>) ESC US (<i>n</i>) ESC h (<i>n</i>)</p>

Function	Command
Set character offset to $n/120$ inch Cancelled by CR or ESC X. ($0 \leq n \leq 63$) ($65 \leq n \leq 127$)	ESC DC1 (n)
Set character pitch to $n/360$ inch ($0 \leq n_1 n_2 n_3 \leq 999$) n_1 , n_2 , and n_3 are the hundreds, tens, and ones digits.	ESC e H (n_1) (n_2) (n_3)
Vertical Control	
Line feed	LF
Reverse line feed	ESC LF
Form feed	FF
Advance paper $n/180$ inch ($0 \leq n \leq 255$)	ESC J (n)
Reverse paper $n/180$ inch ($0 \leq n \leq 255$)	ESC j (n)
Advance paper $n/360$ inch ($0 \leq n_1 n_2 n_3 \leq 999$) n_1 , n_2 and n_3 are the hundreds, tens, and ones digits.	ESC e J (n_1) (n_2) (n_3)
Reverse paper $n/360$ inch ($0 \leq n_1 n_2 n_3 \leq 999$) n_1 , n_2 , and n_3 are the hundreds, tens, and ones digits.	ESC e j (n_1) (n_2) (n_3)
Set line spacing to $1/8$ inch (8 lpi)	ESC 0
Set line spacing to $n/180$ inch ($0 \leq n \leq 255$)	ESC 3 (n)
Set line spacing to $7/60$ inch	ESC 1
Set line spacing to $n/60$ inch ($0 \leq n \leq 127$)	ESC A (n)
Set line spacing to $1/6$ inch (6 lpi) or to the value set with the ESC A command. The preset line spacing command is ESC A (n).	ESC 2
Set line spacing to $n/360$ inch ($0 \leq n_1 n_2 n_3 \leq 999$) n_1 , n_2 , and n_3 are the hundreds, tens, and ones digits.	ESC e V (n_1) (n_2) (n_3)
Set line spacing to $n/360$ inch ($1 \leq n \leq 255$)	FS 3 (n)

Function	Command
Tabulation	
Horizontal tab execution	HT
Set horizontal tabs The values of n_1 to n_k in this command are the ASCII values of the print columns (at the current character width) where you want to set tabs. ($1 \leq n \leq 255$) ($0 \leq k \leq 255$)	ESC D (n_1) ... (n_k) NUL
Move to print column n ($1 \leq n \leq 255$)	ESC HT (n)
Move to dot column $n_1 + n_2 \times 256$ ($0 \leq n_1 \leq 255$) ($0 \leq n_2 \leq 19$) ($0 \leq n_2 \times 256 + n_1 \leq 4896$)	ESC S (n_1) (n_2)
Horizontal relative move by $n/360$ inch ($-999 \leq n_1 \ n_2 \ n_3 \leq +999$) n_1 , n_2 , and n_3 are the hundreds, tens, and ones digits of the distance. s is a plus or minus (+ or -) sign.	ESC e R (s) (n_1) (n_2) (n_3)
Vertical tab execution	VT
Set vertical tabs The values of n_1 to n_k in this command are the ASCII values of the lines (at the current line spacing) where you want to set tabs. ($1 \leq n \leq 255$) ($1 \leq k \leq 64$)	ESC B (n_1) ... (n_k) NUL
Move to line n ($1 \leq n \leq 255$)	ESC VT (n)
Page Formatting	
Set right margin ($0 \leq n \leq 255$)	ESC Q (n)
Set left margin ($0 \leq n \leq 255$)	ESC l (n)
Set perforation skip by n lines ($1 \leq n \leq 127$)	ESC N (n)
Perforation skip off	ESC O
Set page length to n lines ($1 \leq n \leq 127$)	ESC C (n) or ESC FF (n)
Set page length to n inches ($1 \leq n \leq 22$)	ESC C NUL (n) or ESC FF NUL (n)
Set page length to $n/360$ inch ($0 \leq n_1 \ n_2 \leq 255$)	ESC e f (n_1) (n_2)

Function	Command
Color Selection Select printing color <i>n</i> = 0: Black 1: Magenta (red) 2: Cyan (blue) 3: Violet 4: Yellow 5: Orange 6: Green	ESC r (<i>n</i>)
Character Set Control Select character set 1 Appendix E lists the character sets Select character set 2 Appendix E lists the character sets. Select international character set <i>n</i> = 0: USA 1: France 2: Germany 3: United Kingdom 4: Denmark 1/Norway 5: Sweden/Finland 6: Italy 7: Spain 8: Denmark 2 Clear print buffer Select printer Deselect printer (ignore input) Force most significant bit to 1 Force most significant bit to 0 Cancel control over most significant bit Select code table <i>n</i> = 0: Code page 437 1: Code page 850 2: Code page 860 3: Code page 863 4: Code page 865 5: ISO 8859-1/ECMA 94	ESC 7 ESC 6 ESC R (<i>n</i>) CAN DC1 DC3 ESC > ESC = ESC # ESC e C (<i>n</i>)

Function	Command																																																			
Select extended character by character number ($0 \leq n_1 \leq 3, 0 \leq n_2 \leq 9, 0 \leq n_3 \leq 9$) $n_1, n_2,$ and n_3 are the hundreds, tens, and ones digits.	ESC e E (n_1) (n_2) (n_3)																																																			
Word Processing Line justification on Automatically center printing Reset word processing features	ESC m ESC c ESC x																																																			
Font Selection and Downloading Select font m with source and style set by n <ul style="list-style-type: none"> m (bits 0 and 1: Font device select) <table border="1"> <thead> <tr> <th>Bit 1</th> <th>Bit 0</th> <th>Selection of font</th> </tr> </thead> <tbody> <tr> <td>0</td> <td>0</td> <td>Resident font</td> </tr> <tr> <td>0</td> <td>1</td> <td>Download font</td> </tr> <tr> <td>1</td> <td>0</td> <td>Resident font</td> </tr> </tbody> </table> <ul style="list-style-type: none"> m (bits 2 and 3: Specification of print quality) <table border="1"> <thead> <tr> <th>Bit 3</th> <th>Bit 2</th> <th>Print quality</th> </tr> </thead> <tbody> <tr> <td>0</td> <td>0</td> <td>Original quality of font</td> </tr> <tr> <td>0</td> <td>1</td> <td>Letter quality (360 dpi)</td> </tr> <tr> <td>1</td> <td>0</td> <td>Correspondence quality (180 dpi)</td> </tr> <tr> <td>1</td> <td>1</td> <td>Draft quality (120 dpi)</td> </tr> </tbody> </table> <ul style="list-style-type: none"> n (bit 0 to 2: Specification of font number) <p>(1) Resident fonts</p> <table border="1"> <thead> <tr> <th>n</th> <th>$m = 0, 0$</th> <th>$m = 1, 0$</th> </tr> </thead> <tbody> <tr> <td>0</td> <td>Courier 10</td> <td>Dutch 801 Normal</td> </tr> <tr> <td>1</td> <td>Prestige elite 12</td> <td>Dutch 801 Italic</td> </tr> <tr> <td>2</td> <td>Draft</td> <td>Dutch 801 Bold</td> </tr> <tr> <td>3</td> <td>Compression</td> <td>Swiss 721 Normal</td> </tr> <tr> <td>4</td> <td>Boldface PS</td> <td>Swiss 721 Italic</td> </tr> <tr> <td>5</td> <td>Pica 10</td> <td>Swiss 721 Bold</td> </tr> <tr> <td>6</td> <td>Correspondence</td> <td>OCR-B</td> </tr> </tbody> </table>	Bit 1	Bit 0	Selection of font	0	0	Resident font	0	1	Download font	1	0	Resident font	Bit 3	Bit 2	Print quality	0	0	Original quality of font	0	1	Letter quality (360 dpi)	1	0	Correspondence quality (180 dpi)	1	1	Draft quality (120 dpi)	n	$m = 0, 0$	$m = 1, 0$	0	Courier 10	Dutch 801 Normal	1	Prestige elite 12	Dutch 801 Italic	2	Draft	Dutch 801 Bold	3	Compression	Swiss 721 Normal	4	Boldface PS	Swiss 721 Italic	5	Pica 10	Swiss 721 Bold	6	Correspondence	OCR-B	ESC % (m) (n)
Bit 1	Bit 0	Selection of font																																																		
0	0	Resident font																																																		
0	1	Download font																																																		
1	0	Resident font																																																		
Bit 3	Bit 2	Print quality																																																		
0	0	Original quality of font																																																		
0	1	Letter quality (360 dpi)																																																		
1	0	Correspondence quality (180 dpi)																																																		
1	1	Draft quality (120 dpi)																																																		
n	$m = 0, 0$	$m = 1, 0$																																																		
0	Courier 10	Dutch 801 Normal																																																		
1	Prestige elite 12	Dutch 801 Italic																																																		
2	Draft	Dutch 801 Bold																																																		
3	Compression	Swiss 721 Normal																																																		
4	Boldface PS	Swiss 721 Italic																																																		
5	Pica 10	Swiss 721 Bold																																																		
6	Correspondence	OCR-B																																																		

Function	Command
(2) Download fonts <i>n</i> = 0: Download font 0 1: Download font 1	
Select print quality (font attributes) <i>n</i> =0: Letter (360 x 180 dpi) 1: Correspondence (180 x 180 dpi) 2: Draft (120 x 180 dpi) 3: High-speed Draft (90 x 180 dpi)	ESC e q (<i>n</i>)
Select spacing mode (font attributes) <i>n</i> =0: Fixed pitch font 1: Proportional spacing font	ESC e s (<i>n</i>)
Select character pitch (<i>n</i> /360 inch, font attributes) $(0 \leq n_1 \leq 255) (0 \leq n_2 \leq 255)$ $(n = n_1 \times 256 + n_2)$ Ex. <i>n</i> = 36: 10 pitch 30: 12 pitch 24: 15 pitch 21: 17 pitch	ESC e p (<i>n</i> ₁) (<i>n</i> ₂)
Condense/enlarge vertically (font attributes) <i>n</i> =1: Executed 0: Not executed	ESC e A (<i>n</i>)
Select point size (<i>n</i> /1200 inch, font attributes) $(0 \leq n_1 \leq 255) (0 \leq n_2 \leq 255)$ $(n = n_1 \times 256 + n_2)$ Ex. <i>n</i> = 166: 10 point	ESC e v (<i>n</i> ₁) (<i>n</i> ₂)
Select character style (font attributes) <i>n</i> =0: Upright 1: Italic	ESC e i (<i>n</i>)
Select stroke weight (font attributes) <i>n</i> = 249: -7 (Reserved) 251: -5 (Reserved) 253: -3 (light) 0: 0 (medium) 3: 3 (bold) 5: 5 (black) 7: 7 (ultra black)	ESC e w (<i>n</i>)

Command Sets

Function						Command
Select typeface (font attributes)						ESC e t (n)
n=1: Pica						
3: Courier						
4: Swiss 721						
5: Dutch 801						
6: Gothic						
8: Prestige						
23: Boldface						
131: OCR-B						
Select font by I.D. (font attributes)						
n	Quality	Spacing	Pitch	Point	Typeface	
1	LQ	Fixed	10 cpi	12 pt	Courier	
2	LQ	Fixed	12 cpi	10 pt	Prestige	
3	LQ	PS	-	12 pt	Boldface	
4	LQ	Fixed	10 cpi	12 pt	Pica	
10	LQ	Fixed	10 cpi	12 pt	OCR-B	
32	CQ	Fixed	10 cpi	12 pt	Courier	
128	LQ	PS	-	10 pt	Dutch 801 Normal	
129	LQ	PS	-	10 pt	Dutch 801 Italic	
130	LQ	PS	-	10 pt	Dutch 801 Bold	
132	LQ	PS	-	10 pt	Swiss 721 Normal	
133	LQ	PS	-	10 pt	Swiss 721 Italic	
134	LQ	PS	-	10 pt	Swiss 721 Bold	
Copy resident font to download area						ESC : NUL (m) (n)
m=0: Courier 10						
1: Prestige Elite 12						
2: Draft						
3: Compression						
4: Boldface PS						
5: Pica 10						
6: Correspondence						
n=0: Download font 0						
1: Download font 1						

Function		Command											
Create download font • <i>m</i> (bits 4 and 5: Specifies the quality of characters to be registered)		ESC & (<i>m</i>) (<i>Cs</i>) (<i>Ce</i>) (<i>data</i>)											
<table border="1"> <thead> <tr> <th>Bit 5</th> <th>Bit 4</th> <th>Selection of font quality</th> </tr> </thead> <tbody> <tr> <td>0</td> <td>1</td> <td>Letter (360 dpi)</td> </tr> <tr> <td>1</td> <td>0</td> <td>Correspondence (180 dpi)</td> </tr> <tr> <td>1</td> <td>1</td> <td>Draft (120 dpi)</td> </tr> </tbody> </table>	Bit 5		Bit 4	Selection of font quality	0	1	Letter (360 dpi)	1	0	Correspondence (180 dpi)	1	1	Draft (120 dpi)
Bit 5	Bit 4	Selection of font quality											
0	1	Letter (360 dpi)											
1	0	Correspondence (180 dpi)											
1	1	Draft (120 dpi)											
• <i>m</i> (bit 0: Specifies external font number to be registered)													
<table border="1"> <thead> <tr> <th>Bit 0</th> <th>Font number selection</th> <th>Remarks</th> </tr> </thead> <tbody> <tr> <td>0</td> <td>Download font 0</td> <td>At power on, resident font 0 is automatically downloaded.</td> </tr> <tr> <td>1</td> <td>Download font 1</td> <td>At power on, resident font 1 is automatically downloaded.</td> </tr> </tbody> </table>	Bit 0	Font number selection	Remarks	0	Download font 0	At power on, resident font 0 is automatically downloaded.	1	Download font 1	At power on, resident font 1 is automatically downloaded.				
Bit 0	Font number selection	Remarks											
0	Download font 0	At power on, resident font 0 is automatically downloaded.											
1	Download font 1	At power on, resident font 1 is automatically downloaded.											
• <i>m</i> (bits 1, 2, 3, 6, 7) Not used (don't care) • <i>Cs</i> (Download start character of ASCII code) • <i>Ce</i> (Download end character of ASCII code)													
<table border="1"> <tbody> <tr> <td>Decimal</td> <td>$0 \leq Cs, Ce < 255$</td> </tr> <tr> <td>Hex</td> <td>$00 \leq Cs, Ce \leq FF$</td> </tr> </tbody> </table> Precaution: $Ce > Cs$	Decimal	$0 \leq Cs, Ce < 255$	Hex	$00 \leq Cs, Ce \leq FF$									
Decimal	$0 \leq Cs, Ce < 255$												
Hex	$00 \leq Cs, Ce \leq FF$												
• <i>data</i> (Data of more than one byte containing bit map data) (Reserved)		ESC e D (<i>data</i>);											

Function	Command
Bit Image Graphics	
Graphics type m graphics	ESC * (m) (n ₁) (n ₂) (data)
Graphics type m graphics	ESC e b (m) (n ₁) (n ₂) (data)
Single density graphics	ESC K (n ₁) (n ₂) (data)
Double density graphics	ESC L (n ₁) (n ₂) (data)
High-speed double density graphics	ESC Y (n ₁) (n ₂) (data)
Quad density graphics	ESC Z (n ₁) (n ₂) (data)
360 dot per inch 24-pin graphics	FS Z (n ₁) (n ₂) (data)
Cut Sheet Feeder Control	
Feed a sheet from bin 1	ESC EM 1
Feed a sheet from bin 2	ESC EM 2
Feed a sheet from bin 3	ESC EM E
Eject a page from the printer	ESC EM R
Select bin 1 for following pages	// 1 //
Select bin 2 for following pages	// 2 //
Select bin 3 for following pages	// E //
Eject sheet at end of current page	// R //
Change bins at next page	// C //
Initialize Printer	
Reset printer	ESC @
Reset printer	ESC CR P
Initialize printer	ESC SUB I
Bar Code Printing	
Bar code print	ESC DC4 (b) R (c) (w) (h) (a) (ch ₁) ... (ch _n)

Function	Command
Miscellaneous	
Sound the bell	BEL
Enable the paper out sensor	ESC 9
Ignore the paper out sensor	ESC 8
Typewriter mode on/off (on: $n=1$, off: $n=0$)	ESC i (n)
Move print head to home position	ESC <
Unidirectional printing on/off (on: $n=1$, off: $n=0$)	ESC U (n)
Select CR code definition $n=0$: CR = CR only 1: CR = CR + LF	ESC e r (n)
Select LF code definition $n=0$: LF = LF only 1: LF = LF + CR	ESC e ℓ (n)
Message display on LCD	ESC e M (n_1) (n_2) $D_1 - D_n$
Message display time control	ESC e W (n_1) (n_2)
Enter online setup mode	ESC e ONLINE (<i>data</i>)
Move print head (unit: 1/180 inch) ($0 \leq n_1 \leq 255$) ($0 \leq n_2 \leq 255$)	ESC e h (n_1) (n_2)

Factory Default Settings

The following table lists the printer commands that can control options of the items selectable in the setup mode of this printer. Command parameters are omitted.

Item	Selectable options in setup mode	Command
Emulate	<u>DPL24C+</u> , IBMXL24, LQ2500, LQ2550	Controllable in online setup mode
Font	<u>COUR 10</u> , PRSTG 12, COMPRSD, BOLD FCE, PICA 10, CORRESP, DOWNLD 0, DOWNLD 1	ESC e t ESC e F ESC %
Quality	<u>LETTER</u> , REPORT, DRAFT	ESC e q
Pitch	2.5, 3, 5, 6, 10, <u>12</u> , 15, 17, 18, 20 CPI or PROP SP	ESC e p ESC e H ESC h ESC US ESC M ESC P ESC p ESC i ESC e s
Line space	1, 2, 3, 4, 5, <u>6</u> , 7, 8, LPI	ESC e V ESC 0 ESC 1 ESC 2 ESC 3 ESC A
Character width	<u>NORMAL</u> , 2 TIMES, 4 TIMES	ESC W SO or ESC SO (DC4) ESC u ESC !
Character height	<u>NORMAL</u> , 2 TIMES, 4 TIMES	ESC V ESC u

Underline: Factory default

():Cancel command

Item	Selectable options in setup mode	Command
Attributes	<u>NONE</u> , ITALICS, CONDNSD, SHADOW, BOLD	ESC 4 (ESC 5) SI or ESC SI (DC2) ESC E (ESC F) ESC G (ESC H) ESC e i ESC !
Page length	3.0, 3.5, 4.0, 5.0, 5.5, 6.0, 7.0, 8.0, 8.5, <u>11.0</u> , 11.6, 12.0, 14.0, 18.0 IN	ESC C NUL ESC FF NUL ESC C ESC FF
Left end	<u>1</u> , 2, 3, ... , 41 COLM	Controllable in online setup mode
Top margin	<u>1</u> , 2, 3, ... , 10 LINE	Controllable in outline setup mode
Language	USA, UK, GERMAN, FRENCH, ITALIAN, SPANISH, SWEDISH, FINNISH, DANISH 1, DANISH 2, NORWEGN, <u>PAGE437</u> , PAGE850, PAGE860, PAGE863, PAGE865, ISO8859, ECMA94	ESC R ESC e C
	PG852, PG852-T, PG855, PG866, HUNGARY, HUNG-T, YUGO1, YUGO1-T, MAZOWIA, MAZOW-T, POLISH, POLSH-T, LATIN7, LATIN2, LATIN2-T, KAMENIC, KAMEN-T, TURKY, TURKY-T, CYRLIC	Uncontrollable by commands
Character set	SET 1, <u>SET 2</u>	ESC 7 ESC 6
Perforation skip	SKIP, <u>NO-SKIP</u>	ESC N (ESC O)

Underline: Factory default

(): Cancel command

Item	Selectable options in setup mode	Command
Paper width	8.0 IN, 11.0 IN, <u>13.6 IN</u> (11.0 IN is default for 110-column printer)	Controllable in online setup mode
Zero font	<u>NO-SLSH</u> , SLASH	Controllable in online setup mode
DC1/DC3	<u>ENABLE</u> , DISABLE	Controllable in online setup mode
CR code	<u>CR-ONLY</u> , CR & LF	ESC e r
LF code	LF-ONLY, <u>LF & CR</u>	ESC e l
Right end wrap	<u>WRAP</u> , OVR-PRT	Controllable in online setup mode
Paper-out	<u>CN</u> ONLY, DETECT	ESC 9 (ESC 8)
Print direction	<u>BI-DIR</u> , UNI-DIR	ESC U

Underline: Factory default
 (): Cancel command

**IBM PROPRINTER XL24
EMULATION**

This section lists the printer commands for the IBM Proprinter XL24 emulation. Asterisks in the "Function" column indicate extended commands not supported by the original printer. See the *Programmer's Manual (IBM XL24 Emulation)* for detailed information on using these commands.

Function	Command																														
Print Mode Control																															
Double-strike (bold) printing on	ESC G																														
Double-strike (bold) printing off	ESC H																														
Emphasized (shadow) printing on	ESC E																														
Emphasized (shadow) printing off	ESC F																														
One-line double width characters on	SO or ESC SO																														
One-line double width characters off	DC4																														
Double width characters on/off (on: $n = 1$, off: $n = 0$)	ESC W (n)																														
Double height/double width characters $n_1 = 4, n_2 = 0, m_1 = 0, m_2 = 0$ m_3 controls character height and line spacing:	ESC [@ (n_1) (n_2) (m_1) ... (m_4)																														
<table border="1" style="margin-left: auto; margin-right: auto;"> <thead> <tr> <th style="text-align: center;">m_3</th> <th style="text-align: center;">Height</th> <th style="text-align: center;">Spacing</th> </tr> </thead> <tbody> <tr><td style="text-align: center;">0</td><td style="text-align: center;">Unchanged</td><td style="text-align: center;">Unchanged</td></tr> <tr><td style="text-align: center;">1</td><td style="text-align: center;">Normal</td><td style="text-align: center;">Unchanged</td></tr> <tr><td style="text-align: center;">2</td><td style="text-align: center;">Double</td><td style="text-align: center;">Unchanged</td></tr> <tr><td style="text-align: center;">16</td><td style="text-align: center;">Unchanged</td><td style="text-align: center;">Single</td></tr> <tr><td style="text-align: center;">17</td><td style="text-align: center;">Normal</td><td style="text-align: center;">Single</td></tr> <tr><td style="text-align: center;">18</td><td style="text-align: center;">Double</td><td style="text-align: center;">Single</td></tr> <tr><td style="text-align: center;">32</td><td style="text-align: center;">Unchanged</td><td style="text-align: center;">Double</td></tr> <tr><td style="text-align: center;">33</td><td style="text-align: center;">Normal</td><td style="text-align: center;">Double</td></tr> <tr><td style="text-align: center;">34</td><td style="text-align: center;">Double</td><td style="text-align: center;">Double</td></tr> </tbody> </table>	m_3	Height	Spacing	0	Unchanged	Unchanged	1	Normal	Unchanged	2	Double	Unchanged	16	Unchanged	Single	17	Normal	Single	18	Double	Single	32	Unchanged	Double	33	Normal	Double	34	Double	Double	
m_3	Height	Spacing																													
0	Unchanged	Unchanged																													
1	Normal	Unchanged																													
2	Double	Unchanged																													
16	Unchanged	Single																													
17	Normal	Single																													
18	Double	Single																													
32	Unchanged	Double																													
33	Normal	Double																													
34	Double	Double																													
m_4 controls character width:																															
<table border="1" style="margin-left: auto; margin-right: auto;"> <thead> <tr> <th style="text-align: center;">m_4</th> <th style="text-align: center;">Width</th> </tr> </thead> <tbody> <tr><td style="text-align: center;">0</td><td style="text-align: center;">Unchanged</td></tr> <tr><td style="text-align: center;">1</td><td style="text-align: center;">Normal</td></tr> <tr><td style="text-align: center;">2</td><td style="text-align: center;">Double</td></tr> </tbody> </table>	m_4	Width	0	Unchanged	1	Normal	2	Double																							
m_4	Width																														
0	Unchanged																														
1	Normal																														
2	Double																														

Command Sets

Function	Command
Condensed characters on	SI or ESC SI
Condensed and elite characters off	DC2
Subscript or superscript printing on (subscript: $n = 1$, superscript: $n = 0$)	ESC S (n)
Subscript and superscript printing off	ESC T
Underline on/off (on: $n = 1$, off: $n = 0$)	ESC - (n)
Overline on/off (on: $n = 1$, off: $n = 0$)	ESC _ (n)
Horizontal Control	
Space	SP
Backspace	BS
Carriage return	CR
Elite characters on	ESC :
Proportionally spaced characters on/off (on: $n = 1$, off: $n = 0$)	ESC P (n)
Vertical Control	
Line feed	LF
Form feed	FF
Advance paper $n/216$ inch ($0 \leq n \leq 255$)	ESC J (n)
Advance paper $n/180$ inch (in AG mode) ($0 \leq n \leq 255$)	ESC J (n)
Set line spacing to $1/8$ lines	ESC 0
Set line spacing to $7/72$ inch	ESC 1
Set line spacing to $n/216$ inch ($0 \leq n \leq 255$)	ESC 3 (n)
Set line spacing to $n/180$ inch (in AG mode) ($0 \leq n \leq 255$)	ESC 3 (n)
Preset line spacing to $n/72$ inch ($0 \leq n \leq 255$)	ESC A (n)
Preset line spacing to $n/60$ inch (in AG mode) ($0 \leq n \leq 255$)	ESC A (n)
Set line spacing to the preset value The preset line spacing command is ESC A (n).	ESC 2

Function	Command
Change graphics line spacing base to 1/216 or 1/180 inch (for ESC J and ESC 3) $m_1 = 4, m_2 = 0$ $t_1 = \text{any value}, t_2 = \text{any value}, t_3 = 0$ $t_4 = 180 \text{ or } 216$	ESC I \ (m_1) (m_2) (t_1) ... (t_4)
Tabulation Horizontal tab execution Set horizontal tabs The values of n_1 to n_k in this command are the ASCII values of the print columns (at the current character width) where you want to set tabs. ($1 \leq n \leq 255$) ($1 \leq k \leq 28$) Clear all horizontal tabs Move print position right by $n/120$ inch ($0 \leq n_1, n_2 \leq 255$) ($n = n_1 + n_2 \times 256$) Vertical tab execution Set vertical tabs The values of n_1 to n_k in this command are the ASCII values of the lines (at the current line spacing) where you want to set tabs. ($1 \leq n \leq 255$) ($1 \leq k \leq 64$) Clear all vertical tabs Reset tabs to default values	HT ESC D (n_1) ... (n_k) NUL ESC D NUL ESC d (n_1) (n_2) VT ESC B (n_1) ... (n_k) NUL ESC B NUL ESC R
Page Formatting Set left margin at column n and right margin at column m ($0 \leq n, m \leq 255$) Set perforation skip by n lines ($0 \leq n \leq 255$) Perforation skip off Set page length to n lines ($1 \leq n \leq 255$) Set page length to n inches ($1 \leq n \leq 22$) Set top of form	ESC X (n) (m) ESC N (n) ESC O ESC C (n) ESC C NUL (n) ESC 4

Function	Command
<p>Color Selection*</p> <p>Select printing color*</p> <p>$n = 0$: Black</p> <p>1: Magenta (red)</p> <p>2: Cyan (blue)</p> <p>3: Violet</p> <p>4: Yellow</p> <p>5: Orange</p> <p>6: Green</p>	<p>ESC r (n)</p>
<p>Character Set Control</p> <p>Select character set 1</p> <p>Select character set 2</p> <p>Print $n_1 + n_2 \times 256$ characters from all-character set</p> <p>(<i>chars.</i>: characters to be printed)</p> <p>Print a character from all-character set</p> <p>(<i>char.</i>: a character to be printed)</p> <p>Clear input buffer</p> <p>Select printer</p> <p>Deselect printer (ignore input)</p>	<p>ESC 7</p> <p>ESC 6</p> <p>ESC \ (n_1) (n_2) (<i>chars.</i>)</p> <p>ESC ^ (<i>char.</i>)</p> <p>CAN</p> <p>DC1</p> <p>ESC Q #</p>
<p>Downloading</p> <p>Select resident or download font</p> <p>$n = 0$: Resident Draft</p> <p>2: Resident Courier</p> <p>4: Download Draft</p> <p>6: Download Courier</p> <p>Create download font</p>	<p>ESC I (n)</p> <p>ESC = (n_1) (n_2) ID (m_1) (m_2) (<i>data</i>)</p>

Function	Command
Bit Image Graphics Single density graphics Double density graphics High speed double density graphics Quadruple density graphics High-resolution graphics Select graphics mode (in AG mode only)	ESC K $(n_1)(n_2)$ (<i>data</i>) ESC L $(n_1)(n_2)$ (<i>data</i>) ESC Y $(n_1)(n_2)$ (<i>data</i>) ESC Z $(n_1)(n_2)$ (<i>data</i>) ESC [g $(n_1)(n_2)$ (<i>m</i>) (<i>data</i>) ESC * (m) (c_1) (c_2) (<i>data</i>)
Cut Sheet Feeder Control* Feed a sheet from bin 1* Feed a sheet from bin 2* Feed a sheet from bin 3* Eject a page from the printer* Select bin 1 for following pages* Select bin 2 for following pages* Select bin 3 for following pages* Eject sheet at end of current page* Change bins at next page*	ESC EM 1 ESC EM 2 ESC EM E ESC EM R //1// //2// //E// //R// //C//
Miscellaneous Sound the bell Unidirectional printing on/off (on: $n = 1$, off: $n = 0$) Add a carriage return to all line feeds (on: $n = 1$, off: $n = 0$) Printer offline Enter online setup mode	BEL ESC U (n) ESC 5 (n) ESC j ESC e ONLINE (<i>data</i>)

**EPSON LQ-2500/
LQ-2550 EMULATIONS**

This section lists the printer commands for the Epson LQ-2500 and LQ-2550 emulations. Asterisks in the "Function" column indicate extended commands not supported by the original printer. See the *Programmer's Manual (Epson LQ2500/2550 Emulation)* for detailed information on using these commands.

Function	Command
Print Mode Control	
Double-strike (bold) printing on	ESC G
Double-strike (bold) printing off	ESC H
Emphasized (shadow) printing on	ESC E
Emphasized (shadow) printing off	ESC F
Italic printing on	ESC 4
Italic printing off	ESC 5
Select character style*	ESC q (n)
n = 0: Normal	
1: Outlined	
2: Shaded	
3: Outlined and shadowed	
One-line double width characters on	SO or ESC SO
One-line double width characters off	DC4
Double width characters on/off (on: n = 1, off: n = 0)	ESC W (n)
Double height characters on/off* (on: n = 1, off: n = 0)	ESC w (n)
Condensed characters on	SI or ESC SI
Condensed characters off	DC2
Subscript or superscript printing on (subscript: n = 1, superscript: n = 0)	ESC S (n)
Subscript and superscript printing off	ESC T
Underline on/off* (on: n = 1, off: n = 0)	ESC - (n)

Function	Command
<p>Select printing style</p> <p>This command allows you to combine various printing styles. The value of n is the sum of the values of the styles you want to combine.</p> <p>$n = 0$: Pica pitch</p> <p>1: Elite pitch</p> <p>2: Proportional spacing</p> <p>4: Condensed</p> <p>8: Shadow</p> <p>16: Bold</p> <p>32: Double width</p> <p>64: Italics</p> <p>128: Underline</p>	ESC ! (n)
<p>Horizontal Control</p> <p>Space</p> <p>Backspace</p> <p>Carriage return</p> <p>Set elite pitch</p> <p>Set pica pitch</p> <p>Set 15 CPI*</p> <p>Proportionally spaced characters on/off (on: $n = 1$, off: $n = 0$)</p> <p>Set inter-character space to $n/120$ inch (for draft) or $n/180$ inch (for letter) ($0 \leq n \leq 127$)</p>	<p>SP</p> <p>BS</p> <p>CR</p> <p>ESC M</p> <p>ESC P</p> <p>ESC g</p> <p>ESC p (n)</p> <p>ESC SP (n)</p>
<p>Vertical Control</p> <p>Line feed</p> <p>Form feed</p> <p>Advance paper $n/180$ inch ($0 \leq n \leq 255$)</p> <p>Reverse paper $n/180$ inch ($0 \leq n \leq 255$)*</p> <p>Set line spacing to $1/8$ inch</p> <p>Set line spacing to $n/180$ inch ($0 \leq n \leq 255$)</p> <p>Set line spacing to $n/60$ inch ($0 \leq n \leq 127$)</p> <p>Set line spacing to $1/6$ inch</p> <p>Set line spacing to $n/360$ inch ($0 \leq n \leq 255$)</p>	<p>LF</p> <p>FF</p> <p>ESC J (n)</p> <p>ESC j (n)</p> <p>ESC 0</p> <p>ESC 3 (n)</p> <p>ESC A (n)</p> <p>ESC 2</p> <p>ESC + (n)</p>

Function	Command
Tabulation	
Horizontal tab execution	HT
Set horizontal tabs The values of n_1 to n_k in this command are the ASCII values of the print columns (at the current character width) where you want to set tabs. ($1 \leq n \leq 255$) ($1 \leq k \leq 32$)	ESC D (n_1) ... (n_k) NUL
Move print position $n/60$ inch right from left margin ($n = n_1 + n_2 \times 256$)	ESC \$ (n_1) (n_2)
Move print position $n/120$ inch (for draft) or $n/180$ inch (for letter) left or right from the current position ($n = n_1 + n_2 \times 256$)	ESC \ (n_1) (n_2)
Vertical tab execution	VT
Set vertical tabs The values of n_1 to n_k in this command are the ASCII values of the lines (at the current line spacing) where you want to set tabs. ($1 \leq n \leq 255$) ($1 \leq k \leq 16$)	ESC B (n_1) ... (n_k) NUL
Select vertical tabs by channel The values of n_1 - n_k in this command are the ASCII values of the lines (at the current line spacing) where you want to set tabs. ($0 \leq c \leq 7$) ($1 \leq n \leq 255$) ($1 \leq k \leq 16$)	ESC b (c) (n_1)...(n_k) NUL
Select vertical tab channel ($0 \leq c \leq 7$)	ESC / (c)
Page Formatting	
Set right margin to column n ($1 \leq n \leq 255$)	ESC Q (n)
Set left margin to column $n + 1$ ($0 \leq n \leq 255$)	ESC l (n)
Set perforation skip by n lines ($1 \leq n \leq 127$)	ESC N (n)

Function	Command
Perforation skip off	ESC O
Set page length to n lines ($1 \leq n \leq 127$)*	ESC C (n)
Set page length to n inches ($1 \leq n \leq 22$)*	ESC C NUL (n)
Color Selection	
Select printing color	ESC r (n)
$n = 0$: Block	
1: Magenta (red)	
2: Cyan (blue)	
3: Violet	
4: Yellow	
5: Orange	
6: Green	
Character Set Control	
Select character set 2	ESC 7
Select character set 1	ESC 6
Select character set table	ESC t (n)
$n = 0$: Italics character set	
1: Graphics character set	
2: Download character set (LQ-2550 only)	
Select international character set	ESC R (n)
$n = 0$: USA	
1: France	
2: Germany	
3: United Kingdom	
4: Denmark 1	
5: Sweden	
6: Italy	
7: Spanish 1	
8: Japan	
9: Norway	
10: Denmark 2	
11: Spanish 2	
12: Latin America	
Clear input buffer	CAN
Select printer	DC1

Function	Command
Deselect printer (ignore input)*	DC3
Delete a character	DEL
Force most significant bit to 1	ESC >
Force most significant bit to 0	ESC =
Cancel control over most significant bit*	ESC #
Word Processing	
Line justification on*	ESC a (n)
n = 0: Left justify	
1: Center	
2: Right justify	
3: Full justify	
Font Selection and Downloading	
Select font	ESC % (n)
Select letter or draft quality	ESC x (n)
n = 0: Draft	
1: Letter	
Select type style*	ESC k (n)
n = 0: Dutch 801	
1: Swiss 721	
2: Courier (default)	
3: Prestige	
5: OCR-B	
Copy resident font to download area*	ESC : (n ₁) (n ₂) (n ₃)
Create download font*	ESC & NUL (n ₁) (n ₂) (d ₀) (d ₁) (d ₂) (data)

Function	Command
Bit Image Graphics	
Graphics type m graphics	ESC * (m) (n ₁) (n ₂) (data)
Bit image mode definition	ESC ? (s) (n)
Single density graphics	ESC K (n ₁) (n ₂) (data)
Double density graphics	ESC L (n ₁) (n ₂) (data)
High-speed double density graphics	ESC Y (n ₁) (n ₂) (data)
Quadruple density graphics	ESC Z (n ₁) (n ₂) (data)
Cut Sheet Feeder Control	
Feed a sheet from bin 1	ESC EM 1
Feed a sheet from bin 2	ESC EM 2
Feed a sheet from bin 3*	ESC EM E
ASF mode on	ESC EM 4
ASF mode off	ESC EM 0
Eject a page from the printer	ESC EM R
Select bin 1 for following pages*	//1//
Select bin 2 for following pages*	//2//
Select bin 3 for following pages*	//E//
Eject sheet at end of current page*	//R//
Change bins at next page*	//C//
Miscellaneous	
Sound the bell	BEL
Move print head to home position	ESC <
Unidirectional printing on/off (on: n = 1, off: n = 0)	ESC U (n)
Initialize printer*	ESC @
Half speed printing on/off (on: n = 1, off: n = 0)	ESC s (n)
Enter online setup mode	ESC e ONLINE (data)

INTERFACE INFORMATION

This printer can communicate with a computer through either a Centronics parallel interface or an RS-232C serial interface. The printer cannot be equipped with both interfaces at the same time.

This appendix provides information you may need if you are wiring your own interface cables or programming for computer-to-printer communications. Most users do not need to refer to this appendix. If you are simply trying to connect your printer to your computer, check the instructions in Chapter 2.

PARALLEL INTERFACE

The Centronics interface is the industry-standard parallel interface. The cable connector at the printer side should be a shielded Amphenol DDK 57FE-30360 or its equivalent.

The connector pin assignments are shown in the following table. In this table:

- "Input" indicates a signal input to the printer from the computer.
- "Output" indicates a signal output from the printer.
- The return lines specified in the second column represent twisted pairs, with one side connected to signal ground.
- The standard signal levels are 0.0 to +0.4 V for low, and +2.4 to +5.0 V for high.

Pin No.	Return Pin No.	Signal Name	Direction	Description
1	19	Data Strobe	Input	Strobe pulse for reading data. The printer reads data when this signal is low. The pulse width must be 1 μ s or more at the receiving terminal.
2-9	20-27	Data 1 to 8	Input	Data 8 (pin 9) is the most significant bit, but it is not used in 7-bit ASCII communications. All signals that indicate data is logical 1 should go high at least 1 μ s before the falling edge of the Data Strobe signal and must stay high for at least 1 μ s after the rising edge.
10	28	Acknowledge	Output	Pulse signal indicating the printer has received data and is ready to accept the next data. This signal is also issued when the printer is switched from offline to online.
11	29	Busy	Output	Output data cannot be received when this signal is high. This signal goes high during data entry, when the printer is offline, when the buffer is full, or when an error occurs.
12	30	Paper Empty	Output	This signal goes high when the printer is out of paper.
13	-	Select	Output	This signal indicates the selected (online) state when high and the deselected (offline) state when low.

Pin No.	Return Pin No.	Signal Name	Direction	Description
14	-	Auto Feed XT	Input	Not used
15	-	-	-	No connection
16	-	Signal Ground	-	Logic ground level (0 V)
17	-	Frame Ground	-	Printer chassis ground line. FG and SG are connected.
18	-	-	-	No connection
19-30	-	Signal Ground	-	Twisted pair return lines
31	-	Input Prime	Input	If this signal is low for more than 50 μ s, the printer is reset to the initial condition and is placed online.
32	-	Fault	Output	This signal goes low when the printer is offline, paper is out, or when there is a printer error.
33	-	Signal Ground	-	Logic ground level (0 V)
34	-	-	-	No connection
35	-	+5 VR	Output	Pulled up to +5 V through a 3.3 k Ω resistor.
36	-	SLCT-IN	Input	Not used

Data Transmission Timing

The Centronics interface of this printer guarantees the received data when the Data and Data Strobe signals from the computer have the following timing with respect to the Busy and Acknowledge signals from the printer.

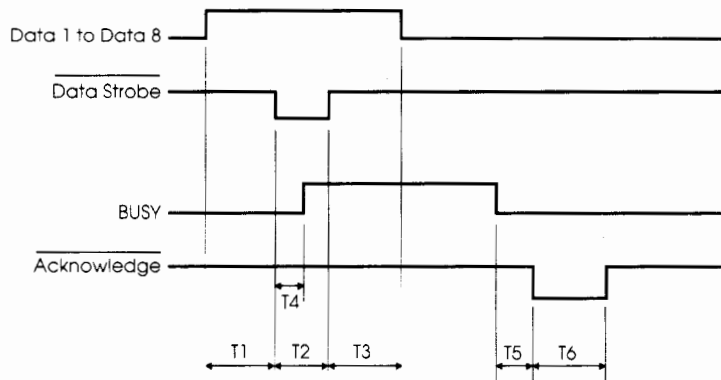

$T1, T2, T3 > 1 \mu s$
 $T4 < 1 \mu s$
 $0 \mu s < T5 < 3 \mu s$
 $2 \mu s < T6 < 6 \mu s$

SERIAL INTERFACE

RS-232C is the standard serial interface for data terminal equipment. The cable connector at the printer side should be a D-subminiature Cannon or Cinch DB-25P male connector or equivalent conforming to EIA standards.

The following table shows the pin assignments that are commonly used by most computers. In this table:

- "Input" indicates a signal input to the printer from the computer.
- "Output" indicates a signal output from the printer.
- The signal level for mark (logical 1) is -3 V or lower; for space (logical 0), it is +3 V or higher.

Pin No.	Signal Name	Direction	Description
1	FG	-	Frame Ground
2	TD	Output	Transmitted Data. This pin carries information from the printer to the computer.
3	RD	Input	Received Data. This pin carries information from the computer to the printer.
4	RTS	Output	Request To Send. Spaces are sent when the printer is ready to transmit data.
5	CTS	Input	Clear To Send. Spaces are sent when the computer is ready to receive data.
6	DSR	Input	Data Set Ready. Spaces are sent when the computer has been powered on and is ready.
7	SG	-	Signal Ground (common return)
8	CD	Input	Data Carrier Detect. Spaces are sent when the computer lets the printer receive data.
11	RC	Output	Reverse Channel. This is used in the RC protocol only. Spaces are sent when the printer is ready to send or receive data.
20	DTR	Output	Data Terminal Ready. Spaces are sent when the printer has been powered on and is ready.

Serial Options

The serial options listed below must be set the same way on both the computer and the printer. Using the printer's control panel, the computer's operating system, or your software, you can change the options specified as "selectable."

Transmission mode:	Asynchronous, full duplex, or half duplex (selectable)
Speeds:	150, 300, 600, 1200, 2400, 4800, 9600, or 19200 baud (selectable)
Data bits:	7 or 8 bits (selectable)
Parity bit:	Odd, even, mark, space, or none (selectable)
Start bit:	1 bit
Stop bit:	1 or 2 bits (selectable)
Protocol:	XON/XOFF (DC1/DC3), DTR (Data Terminal Ready), RC (Reverse Channel), or ETX/ACK (selectable)
Buffer size:	256, 2K, 8K, or 24K bytes (selectable) with the IBM XL24 emulation selected, the size is fixed to 256 bytes.

Cable Wiring

This printer allows two types of serial communication control: DSR enabled and DSR disabled. The type you use is determined by your computer's requirements and affects the way the interface cable is wired. To select between DSR enabled and DSR disabled control, use the printer's HARDWRE function (see Chapter 5).

DSR disabled control offers simpler cabling and communication than DSR enabled control. It can be used for interfacing with an IBM PC or most other personal computers. With DSR disabled control, input control signals DSR, CTS, and CD are always considered high, regardless of their actual states. Therefore, a wire connection for these pins is not required. The following figure shows the wiring required for connection to an IBM PC.

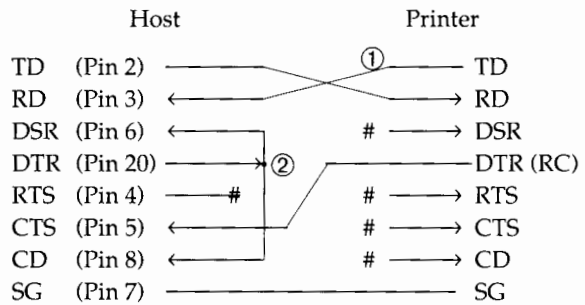

indicates an open wire.
 Wire ① is unnecessary for the DTR (or RC) protocol.
 Some computers may not require wire ②.

DSR enabled control enables communication with an RS-232C interface. The CTS and DSR input control signals are enabled; CD is ignored. DSR must be high when the printer receives data. If the printer has data to be transmitted to the computer, the printer transmits the data immediately when both DSR and CTS are high.

For connection to a DCE (data communications equipment) device using DSR enabled control, use a straight-through cable. For connection to a DTE (data terminal equipment) device, use a null-modem cable as shown below.

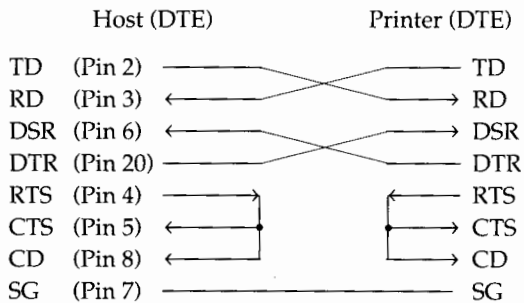

Serial Protocols

A protocol is a set of instructions that control the way data is transmitted between devices such as a computer and printer. The protocol ensures that the computer does not send information to the printer faster than it can be processed. By telling the computer when it can receive data, the protocol prevents the printer's buffer from overflowing.

This printer offers a choice of four different protocols for connection to a variety of computers: XON/XOFF, DTR, RC, and ETX/ACK. The following table describes each protocol. If your computer's documentation does not recommend a particular protocol, try DTR.

Protocol	Description
XON/XOFF (DC1/DC3)	<p>When the printer is ready to receive data, it sends the XON (DC1) code (hex 11). When fewer than 255 bytes of space remain in the buffer (or when the printer is switched offline), the printer sends the XOFF (DC3) code (hex 13). (When the input buffer is configured for 256 bytes, the buffer limit is reduced from 255 bytes to 63 bytes.) The computer must stop transmitting data within 255 (63) characters of receiving the XOFF, or information may be lost. If paper runs out, the printer sends a NAK code (hex 15).</p>
DTR	<p>This is a hardware protocol; that is, the DTR signal on interface cable pin 20 is used to control the flow of data rather than sending a character code. When the printer is ready to receive data, pin 20 is high. When fewer than 255 (63) bytes of space remain in the buffer (or when the printer is switched offline), pin 20 goes low. The computer must stop transmitting data within 255 (63) characters of DTR going low, or information may be lost.</p>
RC	<p>This protocol is the same as the DTR protocol, except that it uses the Reverse Channel signal (pin 11) instead of the Data Terminal Ready signal (pin 20).</p>
ETX/ACK	<p>This protocol is a little more complicated, but allows faster throughput under some conditions. The computer adds the ETX (End of Text) character (hex 03) at the end of each block of print data. The block, including the ETX character, is usually half the printer's input buffer, but it can be as large as the input buffer.</p> <p>When the printer gets the ETX character out of the buffer, it sends an ACK (Acknowledge) character (hex 06) to the computer (the ETX character is not printed). The computer must stop transmitting the next block of data until it receives the ACK character, or information may be lost. Data transmission continues until the printer finishes printing two blocks, so that high-throughput data communication is provided.</p>

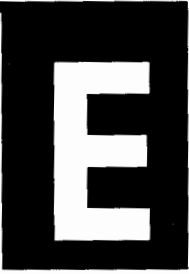

**Character Sets 1 and 2
(DPL24C PLUS and
IBM XL24 Emulation)**

CHARACTER SETS

Below are character sets 1 and 2 of Code Page 437, available in the DPL24C PLUS command set and the IBM Proprinter XL24 emulation.

Characters enclosed in boxes differ for sets 1 and 2. Those of set 2 also vary with the national character set. Code Page 437 is for the USA character set.

Code Page 437 Character Set 1

LNH	0	1	2	3	4	5	6	7	8	9	A	B	C	D	E	F
0	NUL DLE SP	0	@	P	~	p	NUL DLE	á		l	ll	α	≡			
1	SOH DC1 !	1	A	Q	a	q	SOH DC1	í	ó	l	ll	β	±			
2	STX DC2 "	2	B	R	b	r	STX DC2	ô	ú	l	ll	Γ	z			
3	ETX DC3 #	3	C	S	c	s	ETX DC3	û	ñ	l	ll	Π	ζ			
4	BTB DC4 \$	4	D	T	d	t	BTB DC4	ñ	Ñ	l	ll	Σ	η			
5	ENQ NAK %	5	E	U	e	u	ENQ NAK	ã	õ	l	ll	σ	ς			
6	ACK SYN &	6	F	V	f	v	ACK SYN	ä	ö	l	ll	μ	τ			
7	BEL ETB '	7	G	W	g	w	BEL ETB	ø	ï	l	ll	τ	°			
8	BS CAN (8	H	X	h	x	BS CAN	é	ü	l	ll	φ	•			
9	HT EM)	9	I	Y	i	y	HT EM	ê	ú	l	ll	θ	•			
A	LF SUB *	:	J	Z	j	z	LF SUB	ë	û	l	ll	Ω	•			
B	VT ESC +	;	K	[k	{	VT ESC	è	ü	l	ll	δ	√			
C	FF FS ,	<	L	\	l		FF FS	é	ü	l	ll	∞	°			
D	CR GS -	=	M]	m	}	CR GS	ê	ü	l	ll	ø	•			
E	SO RS .	>	N	^	n	~	SO RS	ë	ü	l	ll	€	•			
F	SI US /	?	O	_	o	DEL	SI US	»		l	ll	∩	SP			

Code Page 437 Character Set 2

LNH	0	1	2	3	4	5	6	7	8	9	A	B	C	D	E	F
0	NUL DLE SP	0	@	P	~	p	Ç È	á		l	ll	α	≡			
1	SOH DC1 !	1	A	Q	a	q	Ç È	í	ó	l	ll	β	±			
2	STX DC2 "	2	B	R	b	r	é ê	ô	ú	l	ll	Γ	z			
3	♥ DC3 #	3	C	S	c	s	â ã	û	ñ	l	ll	Π	ζ			
4	♦ DC4 \$	4	D	T	d	t	ä å	ö	ñ	l	ll	Σ	η			
5	♣ \$	5	E	U	e	u	ä å	ö	ñ	l	ll	σ	ς			
6	♠ SYN &	6	F	V	f	v	ä å	ü	ñ	l	ll	μ	τ			
7	BEL ETB '	7	G	W	g	w	ç è	ü	ñ	l	ll	τ	°			
8	BS CAN (8	H	X	h	x	é ê	ý	ü	l	ll	φ	•			
9	HT EM)	9	I	Y	i	y	ë	ö	ü	l	ll	θ	•			
A	LF SUB *	:	J	Z	j	z	è	ü	ü	l	ll	Ω	•			
B	VT ESC +	;	K	[k	{	ï	ø	ü	l	ll	δ	√			
C	FF FS ,	<	L	\	l		ï	ø	ü	l	ll	∞	°			
D	CR GS -	=	M]	m	}	ï	ø	ü	l	ll	ø	•			
E	SO RS .	>	N	^	n	~	Ä Å	Ä Å	»	l	ll	€	•			
F	SI US /	?	O	_	o	DEL	Ä Å	f	»	l	ll	∩	SP			

Italic and Graphics Character Sets (LQ-2500/LQ-2550 Emulation)

The following two pages show character sets available in the Epson LQ-2500/LQ-2550 emulation, each differing in codes 128 to 255 (hex 80 to FF).

Italic Character Set

L/H	0	1	2	3	4	5	6	7	8	9	A	B	C	D	E	F
0	NUL DLE SP	0 @	P ~	p NUL DLE SP	0 @	P ~	p	NUL DLE SP	0 @	P ~	p	NUL DLE SP	0 @	P ~	p	NUL DLE SP
1	SOH DC1 !	1 A	Q a	q SOH DC1 !	1 A	Q a	q	SOH DC1 !	1 A	Q a	q	SOH DC1 !	1 A	Q a	q	SOH DC1 !
2	STX DC2 "	2 B	R b	r STX DC2 "	2 B	R b	r	STX DC2 "	2 B	R b	r	STX DC2 "	2 B	R b	r	STX DC2 "
3	ETX DC3 #	3 C	S c	s ETX DC3 #	3 C	S c	s	ETX DC3 #	3 C	S c	s	ETX DC3 #	3 C	S c	s	ETX DC3 #
4	BOT DC4 \$	4 D	T d	t BOT DC4 \$	4 D	T d	t	BOT DC4 \$	4 D	T d	t	BOT DC4 \$	4 D	T d	t	BOT DC4 \$
5	ENQ NAK %	5 E	U e	u ENQ NAK %	5 E	U e	u	ENQ NAK %	5 E	U e	u	ENQ NAK %	5 E	U e	u	ENQ NAK %
6	ACK SYN &	6 F	V v	v ACK SYN &	6 F	V v	v	ACK SYN &	6 F	V v	v	ACK SYN &	6 F	V v	v	ACK SYN &
7	BEL ETB ' 7	G	W w	w BEL ETB ' 7	G	W w	w	BEL ETB ' 7	G	W w	w	BEL ETB ' 7	G	W w	w	BEL ETB ' 7
8	BS CAN (8	H	X x	x BS CAN (8	H	X x	x	BS CAN (8	H	X x	x	BS CAN (8	H	X x	x	BS CAN (8
9	HT EM) 9	I	Y y	y HT EM) 9	I	Y y	y	HT EM) 9	I	Y y	y	HT EM) 9	I	Y y	y	HT EM) 9
A	LF SUB * : J	Z	j z	z LF SUB * : J	Z	j z	z	LF SUB * : J	Z	j z	z	LF SUB * : J	Z	j z	z	LF SUB * : J
B	VT ESC + ; K	[k {	{ VT ESC + ; K	[k {	{	VT ESC + ; K	[k {	{	VT ESC + ; K	[k {	{	VT ESC + ; K
C	FF FS , < L	\	l	FF FS , < L	\	l		FF FS , < L	\	l		FF FS , < L	\	l		FF FS , < L
D	CR GS - = M]	m }	} CR GS - = M]	m }	}	CR GS - = M]	m }	}	CR GS - = M]	m }	}	CR GS - = M
E	SO RS . > N	^	n ~	~ SO RS . > N	^	n ~	~	SO RS . > N	^	n ~	~	SO RS . > N	^	n ~	~	SO RS . > N
F	SI US / ? 0	_	o	DEL SI US / ? 0	_	o	DEL SI US / ? 0	_	o	DEL SI US / ? 0	_	o	DEL SI US / ? 0	_	o	DEL SI US / ? 0

Graphics Character Set 1

L/H	0	1	2	3	4	5	6	7	8	9	A	B	C	D	E	F
0	NUL DLE SP	0 @	P ~	p NUL DLE SP	0 @	P ~	p	NUL DLE SP	0 @	P ~	p	NUL DLE SP	0 @	P ~	p	NUL DLE SP
1	SOH DC1 !	1 A	Q a	q SOH DC1 !	1 A	Q a	q	SOH DC1 !	1 A	Q a	q	SOH DC1 !	1 A	Q a	q	SOH DC1 !
2	STX DC2 "	2 B	R b	r STX DC2 "	2 B	R b	r	STX DC2 "	2 B	R b	r	STX DC2 "	2 B	R b	r	STX DC2 "
3	ETX DC3 #	3 C	S c	s ETX DC3 #	3 C	S c	s	ETX DC3 #	3 C	S c	s	ETX DC3 #	3 C	S c	s	ETX DC3 #
4	BOT DC4 \$	4 D	T d	t BOT DC4 \$	4 D	T d	t	BOT DC4 \$	4 D	T d	t	BOT DC4 \$	4 D	T d	t	BOT DC4 \$
5	ENQ NAK %	5 E	U e	u ENQ NAK %	5 E	U e	u	ENQ NAK %	5 E	U e	u	ENQ NAK %	5 E	U e	u	ENQ NAK %
6	ACK SYN &	6 F	V v	v ACK SYN &	6 F	V v	v	ACK SYN &	6 F	V v	v	ACK SYN &	6 F	V v	v	ACK SYN &
7	BEL ETB ' 7	G	W w	w BEL ETB ' 7	G	W w	w	BEL ETB ' 7	G	W w	w	BEL ETB ' 7	G	W w	w	BEL ETB ' 7
8	BS CAN (8	H	X x	x BS CAN (8	H	X x	x	BS CAN (8	H	X x	x	BS CAN (8	H	X x	x	BS CAN (8
9	HT EM) 9	I	Y y	y HT EM) 9	I	Y y	y	HT EM) 9	I	Y y	y	HT EM) 9	I	Y y	y	HT EM) 9
A	LF SUB * : J	Z	j z	z LF SUB * : J	Z	j z	z	LF SUB * : J	Z	j z	z	LF SUB * : J	Z	j z	z	LF SUB * : J
B	VT ESC + ; K	[k {	{ VT ESC + ; K	[k {	{	VT ESC + ; K	[k {	{	VT ESC + ; K	[k {	{	VT ESC + ; K
C	FF FS , < L	\	l	FF FS , < L	\	l		FF FS , < L	\	l		FF FS , < L	\	l		FF FS , < L
D	CR GS - = M]	m }	} CR GS - = M]	m }	}	CR GS - = M]	m }	}	CR GS - = M]	m }	}	CR GS - = M
E	SO RS . > N	^	n ~	~ SO RS . > N	^	n ~	~	SO RS . > N	^	n ~	~	SO RS . > N	^	n ~	~	SO RS . > N
F	SI US / ? 0	_	o	DEL SI US / ? 0	_	o	DEL SI US / ? 0	_	o	DEL SI US / ? 0	_	o	DEL SI US / ? 0	_	o	DEL SI US / ? 0

Graphics Character Set 2

L/H	0	1	2	3	4	5	6	7	8	9	A	B	C	D	E	F
0	NUL DLE SP	0	@	P	~	p	ç	é	á							
1	SOH DC1 !	1	A	Q	a	q	ù	æ	í						α	≡
2	STX DC2 "	2	B	R	b	r	é	Æ	ó						β	±
3	ETX DC3 #	3	C	S	c	s	â	ô	û						Γ	≥
4	EOF DC4 \$	4	D	T	d	t	à	ö	ñ						Π	≤
5	ENQ \$ %	5	E	U	e	u	à	ò	Ñ						Σ	∫
6	ACK SYN &	6	F	V	f	v	â	ù	ä						ο	∫
7	BEL ETB '	7	G	W	g	w	ç	ù	ø						μ	±
8	BS CAN (8	H	X	h	x	è	ÿ	ï						τ	°
9	HT EM)	9	I	Y	i	y	è	ö	ü						θ	•
A	LF SUB *	:	J	Z	j	z	è	ü	ü						Ω	·
B	VT ESC + ;	K	[k	{	i	ø	½	¼						δ	√
C	FF FS , <	L	\	l	:	i	£	¼	½						∞	²
D	CR GS - =	M]	m	}	i	ø	¾	¾						∅	■
E	SO RS . >	N	^	n	~	À	À	À	À						Ε	■
F	SI US / ?	O	_	o	DEL	À	À	À	À						∩	SP

Character Sets

**National Character Sets
(All Emulations)**

Below are the 37 national character sets available for all emulations by this printer. They support different characters and symbols specific to different languages. Note that these tables are for Courier 10, a resident font, and that some national character sets do not have some characters and symbols whose use depends on resident fonts. For details, see the table at the end of this appendix.

UK (British English)

L/H	0	1	2	3	4	5	6	7	8	9	A	B	C	D	E	F
0				0	@	P	~	p	Ç	É	á		L	α	≡	
1		!	"	1	A	Q	~	q	ù	æ	í	±	Γ	β	±	
2		"	"	2	B	R	~	r	é	æ	ó	±	Γ	π	±	
3	♥			3	C	S	~	s	è	æ	ó	±	Γ	π	±	
4	♦	#	\$	4	D	T	~	t	à	ö	ñ	±	Σ	σ	±	
5	♣	§	%	5	E	U	~	u	â	ö	ñ	±	Σ	σ	±	
6	♠	&	'	6	F	V	~	v	ä	ü	Ñ	±	Σ	σ	±	
7		()	7	G	W	~	w	ç	ë	ÿ	±	φ	θ	±	
8		()	8	H	X	~	x	ç	ë	ÿ	±	φ	θ	±	
9))	9	I	Y	~	y	è	è	ÿ	±	φ	θ	±	
A		*	:	A	J	Z	~	z	è	è	ÿ	±	φ	θ	±	
B		+	;	B	K	[~	[è	è	ÿ	±	φ	θ	±	
C		,	<	C	L	\	~	\	è	è	ÿ	±	φ	θ	±	
D		-	=	D	M]	~]	è	è	ÿ	±	φ	θ	±	
E		.	>	E	N	^	~	^	è	è	ÿ	±	φ	θ	±	
F		/	?	F	O	_	~	_	è	è	ÿ	±	φ	θ	±	

SWEDISH (Swedish)

L/H	0	1	2	3	4	5	6	7	8	9	A	B	C	D	E	F
0				0	@	P	~	p	Ç	É	á		L	α	≡	
1		!	"	1	A	Q	~	q	ù	æ	í	±	Γ	β	±	
2		"	"	2	B	R	~	r	é	æ	ó	±	Γ	π	±	
3	♥			3	C	S	~	s	è	æ	ó	±	Γ	π	±	
4	♦	#	\$	4	D	T	~	t	à	ö	ñ	±	Σ	σ	±	
5	♣	§	%	5	E	U	~	u	â	ö	ñ	±	Σ	σ	±	
6	♠	&	'	6	F	V	~	v	ä	ü	Ñ	±	Σ	σ	±	
7		()	7	G	W	~	w	ç	ë	ÿ	±	φ	θ	±	
8		()	8	H	X	~	x	ç	ë	ÿ	±	φ	θ	±	
9))	9	I	Y	~	y	è	è	ÿ	±	φ	θ	±	
A		*	:	A	J	Z	~	z	è	è	ÿ	±	φ	θ	±	
B		+	;	B	K	[~	[è	è	ÿ	±	φ	θ	±	
C		,	<	C	L	\	~	\	è	è	ÿ	±	φ	θ	±	
D		-	=	D	M]	~]	è	è	ÿ	±	φ	θ	±	
E		.	>	E	N	^	~	^	è	è	ÿ	±	φ	θ	±	
F		/	?	F	O	_	~	_	è	è	ÿ	±	φ	θ	±	

GERMAN (German)

L/H	0	1	2	3	4	5	6	7	8	9	A	B	C	D	E	F
0				0	\$	P	~	p	Ç	É	á		L	α	≡	
1		!	"	1	A	Q	~	q	ù	æ	í	±	Γ	β	±	
2		"	"	2	B	R	~	r	é	æ	ó	±	Γ	π	±	
3	♥			3	C	S	~	s	è	æ	ó	±	Γ	π	±	
4	♦	#	\$	4	D	T	~	t	à	ö	ñ	±	Σ	σ	±	
5	♣	§	%	5	E	U	~	u	â	ö	ñ	±	Σ	σ	±	
6	♠	&	'	6	F	V	~	v	ä	ü	Ñ	±	Σ	σ	±	
7		()	7	G	W	~	w	ç	ë	ÿ	±	φ	θ	±	
8		()	8	H	X	~	x	ç	ë	ÿ	±	φ	θ	±	
9))	9	I	Y	~	y	è	è	ÿ	±	φ	θ	±	
A		*	:	A	J	Z	~	z	è	è	ÿ	±	φ	θ	±	
B		+	;	B	K	[~	[è	è	ÿ	±	φ	θ	±	
C		,	<	C	L	\	~	\	è	è	ÿ	±	φ	θ	±	
D		-	=	D	M]	~]	è	è	ÿ	±	φ	θ	±	
E		.	>	E	N	^	~	^	è	è	ÿ	±	φ	θ	±	
F		/	?	F	O	_	~	_	è	è	ÿ	±	φ	θ	±	

ISO8859/ECMA94 (ISO 8859-1/ECMA94)

L/H	0	1	2	3	4	5	6	7	8	9	A	B	C	D	E	F
0				0	@	P	~	p								
1		!	"	1	A	Q	~	q								
2		"	"	2	B	R	~	r								
3	♥			3	C	S	~	s								
4	♦	#	\$	4	D	T	~	t								
5	♣	§	%	5	E	U	~	u								
6	♠	&	'	6	F	V	~	v								
7		()	7	G	W	~	w								
8		()	8	H	X	~	x								
9))	9	I	Y	~	y								
A		*	:	A	J	Z	~	z								
B		+	;	B	K	[~	[
C		,	<	C	L	\	~	\								
D		-	=	D	M]	~]								
E		.	>	E	N	^	~	^								
F		/	?	F	O	_	~	_								

PAGE437/USA (Code Page 437/USA)

L/H	0	1	2	3	4	5	6	7	8	9	A	B	C	D	E	F
0				@	P	`	p	ç	é	á	⋮	⋮	⋮	⋮	⋮	⋮
1		!	1	A	Q	a	q	ç	é	á	⋮	⋮	⋮	⋮	⋮	⋮
2		"	2	B	R	b	r	ç	é	á	⋮	⋮	⋮	⋮	⋮	⋮
3	♥	#	3	C	S	c	s	ç	é	á	⋮	⋮	⋮	⋮	⋮	⋮
4	♦	\$	4	D	T	d	t	ç	é	á	⋮	⋮	⋮	⋮	⋮	⋮
5	♣	%	5	E	U	e	u	ç	é	á	⋮	⋮	⋮	⋮	⋮	⋮
6	♠	&	6	F	V	f	v	ç	é	á	⋮	⋮	⋮	⋮	⋮	⋮
7		'	7	G	W	g	w	ç	é	á	⋮	⋮	⋮	⋮	⋮	⋮
8		(8	H	X	h	x	ç	é	á	⋮	⋮	⋮	⋮	⋮	⋮
9)	9	I	Y	i	y	ç	é	á	⋮	⋮	⋮	⋮	⋮	⋮
A		*	:	J	Z	j	z	ç	é	á	⋮	⋮	⋮	⋮	⋮	⋮
B		+	;	K	[k	l	ç	é	á	⋮	⋮	⋮	⋮	⋮	⋮
C		,	<	L	\	l	m	ç	é	á	⋮	⋮	⋮	⋮	⋮	⋮
D		-	=	M]	m	n	ç	é	á	⋮	⋮	⋮	⋮	⋮	⋮
E		.	>	N	^	n	o	ç	é	á	⋮	⋮	⋮	⋮	⋮	⋮
F		/	?	O	_	o		ç	é	á	⋮	⋮	⋮	⋮	⋮	⋮

PG852/PG852-T (Code Page 852)

L/H	0	1	2	3	4	5	6	7	8	9	A	B	C	D	E	F
0				@	P	`	p	ç	é	á	⋮	⋮	⋮	⋮	⋮	⋮
1		!	1	A	Q	a	q	ç	é	á	⋮	⋮	⋮	⋮	⋮	⋮
2		"	2	B	R	b	r	ç	é	á	⋮	⋮	⋮	⋮	⋮	⋮
3	♥	#	3	C	S	c	s	ç	é	á	⋮	⋮	⋮	⋮	⋮	⋮
4	♦	\$	4	D	T	d	t	ç	é	á	⋮	⋮	⋮	⋮	⋮	⋮
5	♣	%	5	E	U	e	u	ç	é	á	⋮	⋮	⋮	⋮	⋮	⋮
6	♠	&	6	F	V	f	v	ç	é	á	⋮	⋮	⋮	⋮	⋮	⋮
7		'	7	G	W	g	w	ç	é	á	⋮	⋮	⋮	⋮	⋮	⋮
8		(8	H	X	h	x	ç	é	á	⋮	⋮	⋮	⋮	⋮	⋮
9)	9	I	Y	i	y	ç	é	á	⋮	⋮	⋮	⋮	⋮	⋮
A		*	:	J	Z	j	z	ç	é	á	⋮	⋮	⋮	⋮	⋮	⋮
B		+	;	K	[k	l	ç	é	á	⋮	⋮	⋮	⋮	⋮	⋮
C		,	<	L	\	l	m	ç	é	á	⋮	⋮	⋮	⋮	⋮	⋮
D		-	=	M]	m	n	ç	é	á	⋮	⋮	⋮	⋮	⋮	⋮
E		.	>	N	^	n	o	ç	é	á	⋮	⋮	⋮	⋮	⋮	⋮
F		/	?	O	_	o		ç	é	á	⋮	⋮	⋮	⋮	⋮	⋮

PAGE850 (Code Page 850(Multilingual))

L/H	0	1	2	3	4	5	6	7	8	9	A	B	C	D	E	F
0				@	P	`	p	ç	é	á	⋮	⋮	⋮	⋮	⋮	⋮
1		!	1	A	Q	a	q	ç	é	á	⋮	⋮	⋮	⋮	⋮	⋮
2		"	2	B	R	b	r	ç	é	á	⋮	⋮	⋮	⋮	⋮	⋮
3	♥	#	3	C	S	c	s	ç	é	á	⋮	⋮	⋮	⋮	⋮	⋮
4	♦	\$	4	D	T	d	t	ç	é	á	⋮	⋮	⋮	⋮	⋮	⋮
5	♣	%	5	E	U	e	u	ç	é	á	⋮	⋮	⋮	⋮	⋮	⋮
6	♠	&	6	F	V	f	v	ç	é	á	⋮	⋮	⋮	⋮	⋮	⋮
7		'	7	G	W	g	w	ç	é	á	⋮	⋮	⋮	⋮	⋮	⋮
8		(8	H	X	h	x	ç	é	á	⋮	⋮	⋮	⋮	⋮	⋮
9)	9	I	Y	i	y	ç	é	á	⋮	⋮	⋮	⋮	⋮	⋮
A		*	:	J	Z	j	z	ç	é	á	⋮	⋮	⋮	⋮	⋮	⋮
B		+	;	K	[k	l	ç	é	á	⋮	⋮	⋮	⋮	⋮	⋮
C		,	<	L	\	l	m	ç	é	á	⋮	⋮	⋮	⋮	⋮	⋮
D		-	=	M]	m	n	ç	é	á	⋮	⋮	⋮	⋮	⋮	⋮
E		.	>	N	^	n	o	ç	é	á	⋮	⋮	⋮	⋮	⋮	⋮
F		/	?	O	_	o		ç	é	á	⋮	⋮	⋮	⋮	⋮	⋮

PG855 (Code Page 855)

L/H	0	1	2	3	4	5	6	7	8	9	A	B	C	D	E	F
0				@	P	`	p	ç	é	á	⋮	⋮	⋮	⋮	⋮	⋮
1		!	1	A	Q	a	q	ç	é	á	⋮	⋮	⋮	⋮	⋮	⋮
2		"	2	B	R	b	r	ç	é	á	⋮	⋮	⋮	⋮	⋮	⋮
3	♥	#	3	C	S	c	s	ç	é	á	⋮	⋮	⋮	⋮	⋮	⋮
4	♦	\$	4	D	T	d	t	ç	é	á	⋮	⋮	⋮	⋮	⋮	⋮
5	♣	%	5	E	U	e	u	ç	é	á	⋮	⋮	⋮	⋮	⋮	⋮
6	♠	&	6	F	V	f	v	ç	é	á	⋮	⋮	⋮	⋮	⋮	⋮
7		'	7	G	W	g	w	ç	é	á	⋮	⋮	⋮	⋮	⋮	⋮
8		(8	H	X	h	x	ç	é	á	⋮	⋮	⋮	⋮	⋮	⋮
9)	9	I	Y	i	y	ç	é	á	⋮	⋮	⋮	⋮	⋮	⋮
A		*	:	J	Z	j	z	ç	é	á	⋮	⋮	⋮	⋮	⋮	⋮
B		+	;	K	[k	l	ç	é	á	⋮	⋮	⋮	⋮	⋮	⋮
C		,	<	L	\	l	m	ç	é	á	⋮	⋮	⋮	⋮	⋮	⋮
D		-	=	M]	m	n	ç	é	á	⋮	⋮	⋮	⋮	⋮	⋮
E		.	>	N	^	n	o	ç	é	á	⋮	⋮	⋮	⋮	⋮	⋮
F		/	?	O	_	o		ç	é	á	⋮	⋮	⋮	⋮	⋮	⋮

Character Sets

CHARACTER SETS

PAGE860 (Code Page 860(Portugal))

L/H	0	1	2	3	4	5	6	7	8	9	A	B	C	D	E	F
0				@	P	^	ç	É	á	í	ó	ú	ñ	ã	õ	ø
1		!	"	A	Q	^	ç	É	á	í	ó	ú	ñ	ã	õ	ø
2		!	"	B	R	^	ç	É	á	í	ó	ú	ñ	ã	õ	ø
3	♥	#	\$	C	S	^	ç	É	á	í	ó	ú	ñ	ã	õ	ø
4	♦	#	\$	D	T	^	ç	É	á	í	ó	ú	ñ	ã	õ	ø
5	♣	§	%	E	U	^	ç	É	á	í	ó	ú	ñ	ã	õ	ø
6	♠	&	'	F	V	^	ç	É	á	í	ó	ú	ñ	ã	õ	ø
7		()	G	W	^	ç	É	á	í	ó	ú	ñ	ã	õ	ø
8		*	:	H	X	^	ç	É	á	í	ó	ú	ñ	ã	õ	ø
9		,	<	I	Y	^	ç	É	á	í	ó	ú	ñ	ã	õ	ø
A		.	>	J	Z	^	ç	É	á	í	ó	ú	ñ	ã	õ	ø
B		/	?	K	[^	ç	É	á	í	ó	ú	ñ	ã	õ	ø
C				L	\	^	ç	É	á	í	ó	ú	ñ	ã	õ	ø
D				M]	^	ç	É	á	í	ó	ú	ñ	ã	õ	ø
E				N	^	^	^	^	^	^	^	^	^	^	^	^
F				O	_	^	^	^	^	^	^	^	^	^	^	^

PAGE865 (Code Page 865(Nordic))

L/H	0	1	2	3	4	5	6	7	8	9	A	B	C	D	E	F
0				@	P	^	ç	É	á	í	ó	ú	ñ	ã	õ	ø
1		!	"	A	Q	^	ç	É	á	í	ó	ú	ñ	ã	õ	ø
2		!	"	B	R	^	ç	É	á	í	ó	ú	ñ	ã	õ	ø
3	♥	#	\$	C	S	^	ç	É	á	í	ó	ú	ñ	ã	õ	ø
4	♦	#	\$	D	T	^	ç	É	á	í	ó	ú	ñ	ã	õ	ø
5	♣	§	%	E	U	^	ç	É	á	í	ó	ú	ñ	ã	õ	ø
6	♠	&	'	F	V	^	ç	É	á	í	ó	ú	ñ	ã	õ	ø
7		()	G	W	^	ç	É	á	í	ó	ú	ñ	ã	õ	ø
8		*	:	H	X	^	ç	É	á	í	ó	ú	ñ	ã	õ	ø
9		,	<	I	Y	^	ç	É	á	í	ó	ú	ñ	ã	õ	ø
A		.	>	J	Z	^	ç	É	á	í	ó	ú	ñ	ã	õ	ø
B		/	?	K	[^	ç	É	á	í	ó	ú	ñ	ã	õ	ø
C				L	\	^	ç	É	á	í	ó	ú	ñ	ã	õ	ø
D				M]	^	ç	É	á	í	ó	ú	ñ	ã	õ	ø
E				N	^	^	^	^	^	^	^	^	^	^	^	^
F				O	_	^	^	^	^	^	^	^	^	^	^	^

PAGE863 (Code Page 863(Canada-French))

L/H	0	1	2	3	4	5	6	7	8	9	A	B	C	D	E	F
0				@	P	^	ç	É	á	í	ó	ú	ñ	ã	õ	ø
1		!	"	A	Q	^	ç	É	á	í	ó	ú	ñ	ã	õ	ø
2		!	"	B	R	^	ç	É	á	í	ó	ú	ñ	ã	õ	ø
3	♥	#	\$	C	S	^	ç	É	á	í	ó	ú	ñ	ã	õ	ø
4	♦	#	\$	D	T	^	ç	É	á	í	ó	ú	ñ	ã	õ	ø
5	♣	§	%	E	U	^	ç	É	á	í	ó	ú	ñ	ã	õ	ø
6	♠	&	'	F	V	^	ç	É	á	í	ó	ú	ñ	ã	õ	ø
7		()	G	W	^	ç	É	á	í	ó	ú	ñ	ã	õ	ø
8		*	:	H	X	^	ç	É	á	í	ó	ú	ñ	ã	õ	ø
9		,	<	I	Y	^	ç	É	á	í	ó	ú	ñ	ã	õ	ø
A		.	>	J	Z	^	ç	É	á	í	ó	ú	ñ	ã	õ	ø
B		/	?	K	[^	ç	É	á	í	ó	ú	ñ	ã	õ	ø
C				L	\	^	ç	É	á	í	ó	ú	ñ	ã	õ	ø
D				M]	^	ç	É	á	í	ó	ú	ñ	ã	õ	ø
E				N	^	^	^	^	^	^	^	^	^	^	^	^
F				O	_	^	^	^	^	^	^	^	^	^	^	^

PG866 (Code Page 866(Cyrillic))

L/H	0	1	2	3	4	5	6	7	8	9	A	B	C	D	E	F
0				@	P	^	ç	É	á	í	ó	ú	ñ	ã	õ	ø
1		!	"	A	Q	^	ç	É	á	í	ó	ú	ñ	ã	õ	ø
2		!	"	B	R	^	ç	É	á	í	ó	ú	ñ	ã	õ	ø
3	♥	#	\$	C	S	^	ç	É	á	í	ó	ú	ñ	ã	õ	ø
4	♦	#	\$	D	T	^	ç	É	á	í	ó	ú	ñ	ã	õ	ø
5	♣	§	%	E	U	^	ç	É	á	í	ó	ú	ñ	ã	õ	ø
6	♠	&	'	F	V	^	ç	É	á	í	ó	ú	ñ	ã	õ	ø
7		()	G	W	^	ç	É	á	í	ó	ú	ñ	ã	õ	ø
8		*	:	H	X	^	ç	É	á	í	ó	ú	ñ	ã	õ	ø
9		,	<	I	Y	^	ç	É	á	í	ó	ú	ñ	ã	õ	ø
A		.	>	J	Z	^	ç	É	á	í	ó	ú	ñ	ã	õ	ø
B		/	?	K	[^	ç	É	á	í	ó	ú	ñ	ã	õ	ø
C				L	\	^	ç	É	á	í	ó	ú	ñ	ã	õ	ø
D				M]	^	ç	É	á	í	ó	ú	ñ	ã	õ	ø
E				N	^	^	^	^	^	^	^	^	^	^	^	^
F				O	_	^	^	^	^	^	^	^	^	^	^	^

HUNGARY/HUNG-T (Hungarian)

L/H	0	1	2	3	4	5	6	7	8	9	A	B	C	D	E	F
0					0	@	P	`	p	Ç	É	Á	:	L	α	≡
1		!	1	A	Q	R	a	q	ü	æ	í	ó	:	l	β	±
2		"	2	B	R	R	b	r	é	æ	ó	ú	:	l	Γ	≥
3	♥		#	3	C	S	c	s	â	ô	ú	ñ	:	l	π	≤
4	♦		\$	4	D	T	d	t	â	ô	ú	ñ	:	l	Σ	∫
5	♣	§	%	5	E	U	e	u	â	ô	ú	ñ	:	l	σ	μ
6	♠		&	6	F	V	f	v	â	ô	ú	ñ	:	l	τ	≈
7			'	7	G	W	g	w	ç	ë	ö	ç	:	l	φ	°
8			(8	H	X	h	x	ç	ë	ö	ç	:	l	θ	•
9)	9	I	Y	i	y	ç	ë	ö	ç	:	l	Ω	•
A		*	:	J	Z	j	z	ç	ë	ö	ç	:	l	∞	•	
B		+	;	K	I	k	i	ç	ë	ö	ç	:	l	∞	√	
C		,	<	L	M	l	m	ç	ë	ö	ç	:	l	∞	n	
D		-	=	M	J	j	ç	ë	ö	ç	:	l	∞	∅	2	
E		.	>	N	O	o	ç	ë	ö	ç	:	l	∞	∅	2	
F		/	?	O	-	o	ç	ë	ö	ç	:	l	∞	∅	2	

POLISH/POLSH-T (Polish)

L/H	0	1	2	3	4	5	6	7	8	9	A	B	C	D	E	F
0					0	@	P	`	p	Ç	Ę	Ż	:	L	α	-
1		!	1	A	Q	R	a	q	ü	ę	ł	ż	:	l	β	~
2		"	2	B	R	R	b	r	é	ł	ó	ń	:	l	Γ	˘
3	♥		#	3	C	S	c	s	â	ô	ú	ñ	:	l	π	˙
4	♦		\$	4	D	T	d	t	â	ô	ú	ñ	:	l	Σ	˙
5	♣	§	%	5	E	U	e	u	â	ô	ú	ñ	:	l	σ	˙
6	♠		&	6	F	V	f	v	â	ô	ú	ñ	:	l	τ	˙
7			'	7	G	W	g	w	ç	ë	ö	ç	:	l	φ	˙
8			(8	H	X	h	x	ç	ë	ö	ç	:	l	θ	˙
9)	9	I	Y	i	y	ç	ë	ö	ç	:	l	Ω	˙
A		*	:	J	Z	j	z	ç	ë	ö	ç	:	l	∞	˙	
B		+	;	K	I	k	i	ç	ë	ö	ç	:	l	∞	˙	
C		,	<	L	M	l	m	ç	ë	ö	ç	:	l	∞	˙	
D		-	=	M	J	j	ç	ë	ö	ç	:	l	∞	˙	2	
E		.	>	N	O	o	ç	ë	ö	ç	:	l	∞	˙	2	
F		/	?	O	-	o	ç	ë	ö	ç	:	l	∞	˙	2	

SLOV/SLOV-T (Slovenian)

L/H	0	1	2	3	4	5	6	7	8	9	A	B	C	D	E	F
0					0	Ž	P	ž	p	Ç	É	Á	:	L	α	≡
1		!	1	A	Q	R	a	q	ü	æ	í	ó	:	l	β	±
2		"	2	B	R	R	b	r	é	æ	ó	ú	:	l	Γ	≥
3	♥		#	3	C	S	c	s	â	ô	ú	ñ	:	l	π	≤
4	♦		\$	4	D	T	d	t	â	ô	ú	ñ	:	l	Σ	∫
5	♣	§	%	5	E	U	e	u	â	ô	ú	ñ	:	l	σ	μ
6	♠		&	6	F	V	f	v	â	ô	ú	ñ	:	l	τ	≈
7			'	7	G	W	g	w	ç	ë	ö	ç	:	l	φ	°
8			(8	H	X	h	x	ç	ë	ö	ç	:	l	θ	•
9)	9	I	Y	i	y	ç	ë	ö	ç	:	l	Ω	•
A		*	:	J	Z	j	z	ç	ë	ö	ç	:	l	∞	•	
B		+	;	K	Š	k	š	ç	ë	ö	ç	:	l	∞	√	
C		,	<	L	Đ	l	đ	ç	ë	ö	ç	:	l	∞	n	
D		-	=	M	Č	m	č	ç	ë	ö	ç	:	l	∞	∅	
E		.	>	N	Č	o	č	ç	ë	ö	ç	:	l	∞	∅	
F		/	?	O	-	o	č	ç	ë	ö	ç	:	l	∞	∅	

MAZOWIA/MAZOW-T (Mazowian)

L/H	0	1	2	3	4	5	6	7	8	9	A	B	C	D	E	F
0					0	@	P	`	p	Ç	Ę	Ż	:	L	α	≡
1		!	1	A	Q	R	a	q	ü	ę	ł	ż	:	l	β	±
2		"	2	B	R	R	b	r	é	ł	ó	ń	:	l	Γ	≥
3	♥		#	3	C	S	c	s	â	ô	ú	ñ	:	l	π	≤
4	♦		\$	4	D	T	d	t	â	ô	ú	ñ	:	l	Σ	∫
5	♣	§	%	5	E	U	e	u	â	ô	ú	ñ	:	l	σ	μ
6	♠		&	6	F	V	f	v	â	ô	ú	ñ	:	l	τ	≈
7			'	7	G	W	g	w	ç	ë	ö	ç	:	l	φ	°
8			(8	H	X	h	x	ç	ë	ö	ç	:	l	θ	•
9)	9	I	Y	i	y	ç	ë	ö	ç	:	l	Ω	•
A		*	:	J	Z	j	z	ç	ë	ö	ç	:	l	∞	•	
B		+	;	K	I	k	i	ç	ë	ö	ç	:	l	∞	√	
C		,	<	L	M	l	m	ç	ë	ö	ç	:	l	∞	n	
D		-	=	M	J	j	ç	ë	ö	ç	:	l	∞	∅	2	
E		.	>	N	O	o	ç	ë	ö	ç	:	l	∞	∅	2	
F		/	?	O	-	o	ç	ë	ö	ç	:	l	∞	∅	2	

CHARACTER SETS

LATIN7 (Latin7)

L/H	0	1	2	3	4	5	6	7	8	9	A	B	C	D	E	F
0				0	@	P	~	p			°	ł	Π	à	π	
1		!	1	A	Q	R	~	a	q	r	´	±	À	Þ	à	þ
2		"	2	B	R	S	~	b	r	s	ˆ	ˆ	Á	Û	á	Û
3	♥	#	3	C	S	T	~	c	s	t	ˆ	ˆ	Â	Ü	â	Ü
4	♦	\$	4	D	T	U	~	d	t	u	ˆ	ˆ	Ã	Û	ã	Û
5	♣	%	5	E	U	V	~	e	u	v	ˆ	ˆ	Ä	Ü	ä	Ü
6		&	6	F	V	W	~	f	v	w	ˆ	ˆ	Å	Ü	å	Ü
7		'	7	G	W	X	~	g	w	x	ˆ	ˆ	Æ	Ü	æ	Ü
8		(8	H	X	Y	~	h	x	y	ˆ	ˆ	Ç	Ü	ç	Ü
9)	9	I	Y	Z	~	i	y	z	ˆ	ˆ	È	Ü	è	Ü
A		*	A	J	Z	[~	j	z	[ˆ	ˆ	É	Ü	é	Ü
B		+	B	K	[\	~	k	[\	ˆ	ˆ	Ê	Ü	ê	Ü
C		,	C	L	\		~	l	\		ˆ	ˆ	Ë	Ü	ë	Ü
D		-	D	M]	~	m]	ˆ	ˆ	Ï	Ü	ï	Ü
E		.	E	N]	^	~	n]	^	ˆ	ˆ	Ï	Ü	ï	Ü
F		/	F	O	^	_	~	o	^	_	ˆ	ˆ	Ï	Ü	ï	Ü

KAMENIC/KAMEN-T (Kamenicky)

L/H	0	1	2	3	4	5	6	7	8	9	A	B	C	D	E	F
0				0	@	P	~	p	Č	É	á	ı	ı	ı	ı	ı
1		!	1	A	Q	R	~	a	č	é	á	ı	ı	ı	ı	ı
2		"	2	B	R	S	~	b	ř	ó	í	ı	ı	ı	ı	ı
3	♥	#	3	C	S	T	~	c	š	ň	ó	ı	ı	ı	ı	ı
4	♦	\$	4	D	T	U	~	d	š	ň	ó	ı	ı	ı	ı	ı
5	♣	%	5	E	U	V	~	e	š	ň	ó	ı	ı	ı	ı	ı
6		&	6	F	V	W	~	f	š	ň	ó	ı	ı	ı	ı	ı
7		'	7	G	W	X	~	g	š	ň	ó	ı	ı	ı	ı	ı
8		(8	H	X	Y	~	h	š	ň	ó	ı	ı	ı	ı	ı
9)	9	I	Y	Z	~	i	š	ň	ó	ı	ı	ı	ı	ı
A		*	A	J	Z	[~	j	š	ň	ó	ı	ı	ı	ı	ı
B		+	B	K	[\	~	k	š	ň	ó	ı	ı	ı	ı	ı
C		,	C	L	\		~	l	š	ň	ó	ı	ı	ı	ı	ı
D		-	D	M]	~	m	š	ň	ó	ı	ı	ı	ı	ı
E		.	E	N]	^	~	n	š	ň	ó	ı	ı	ı	ı	ı
F		/	F	O	^	_	~	o	š	ň	ó	ı	ı	ı	ı	ı

LATIN2/LATN2-T (Latin2)

L/H	0	1	2	3	4	5	6	7	8	9	A	B	C	D	E	F
0				0	@	P	~	p	Ç	É	á	ı	ı	ı	ı	ı
1		!	1	A	Q	R	~	a	ç	é	á	ı	ı	ı	ı	ı
2		"	2	B	R	S	~	b	ş	ö	ı	ı	ı	ı	ı	ı
3	♥	#	3	C	S	T	~	c	ş	ö	ı	ı	ı	ı	ı	ı
4	♦	\$	4	D	T	U	~	d	ş	ö	ı	ı	ı	ı	ı	ı
5	♣	%	5	E	U	V	~	e	ş	ö	ı	ı	ı	ı	ı	ı
6		&	6	F	V	W	~	f	ş	ö	ı	ı	ı	ı	ı	ı
7		'	7	G	W	X	~	g	ş	ö	ı	ı	ı	ı	ı	ı
8		(8	H	X	Y	~	h	ş	ö	ı	ı	ı	ı	ı	ı
9)	9	I	Y	Z	~	i	ş	ö	ı	ı	ı	ı	ı	ı
A		*	A	J	Z	[~	j	ş	ö	ı	ı	ı	ı	ı	ı
B		+	B	K	[\	~	k	ş	ö	ı	ı	ı	ı	ı	ı
C		,	C	L	\		~	l	ş	ö	ı	ı	ı	ı	ı	ı
D		-	D	M]	~	m	ş	ö	ı	ı	ı	ı	ı	ı
E		.	E	N]	^	~	n	ş	ö	ı	ı	ı	ı	ı	ı
F		/	F	O	^	_	~	o	ş	ö	ı	ı	ı	ı	ı	ı

TURKY/TURKY-T (Turkish)

L/H	0	1	2	3	4	5	6	7	8	9	A	B	C	D	E	F
0				0	@	P	~	p	Ç	É	á	ı	ı	ı	ı	ı
1		!	1	A	Q	R	~	a	ç	é	á	ı	ı	ı	ı	ı
2		"	2	B	R	S	~	b	ş	ö	ı	ı	ı	ı	ı	ı
3	♥	#	3	C	S	T	~	c	ş	ö	ı	ı	ı	ı	ı	ı
4	♦	\$	4	D	T	U	~	d	ş	ö	ı	ı	ı	ı	ı	ı
5	♣	%	5	E	U	V	~	e	ş	ö	ı	ı	ı	ı	ı	ı
6		&	6	F	V	W	~	f	ş	ö	ı	ı	ı	ı	ı	ı
7		'	7	G	W	X	~	g	ş	ö	ı	ı	ı	ı	ı	ı
8		(8	H	X	Y	~	h	ş	ö	ı	ı	ı	ı	ı	ı
9)	9	I	Y	Z	~	i	ş	ö	ı	ı	ı	ı	ı	ı
A		*	A	J	Z	[~	j	ş	ö	ı	ı	ı	ı	ı	ı
B		+	B	K	[\	~	k	ş	ö	ı	ı	ı	ı	ı	ı
C		,	C	L	\		~	l	ş	ö	ı	ı	ı	ı	ı	ı
D		-	D	M]	~	m	ş	ö	ı	ı	ı	ı	ı	ı
E		.	E	N]	^	~	n	ş	ö	ı	ı	ı	ı	ı	ı
F		/	F	O	^	_	~	o	ş	ö	ı	ı	ı	ı	ı	ı

CHARACTER SETS

PG-DHN (Code Page DHN)

L/H	0	1	2	3	4	5	6	7	8	9	A	B	C	D	E	F
0					@	P	~	p	Å	á	í	ı	ı	ı	ı	ı
1		!	1	A	Q	R	~	a	Å	á	ı	ı	ı	ı	ı	ı
2		"	2	B	R	S	~	b	Å	á	ı	ı	ı	ı	ı	ı
3	♥	#	3	C	S	T	~	c	Å	á	ı	ı	ı	ı	ı	ı
4	♦	\$	4	D	T	U	~	d	Å	á	ı	ı	ı	ı	ı	ı
5	♣	%	5	E	F	V	~	e	Å	á	ı	ı	ı	ı	ı	ı
6	♠	&	6	F	V	W	~	f	Å	á	ı	ı	ı	ı	ı	ı
7		'	7	G	W	X	~	g	Å	á	ı	ı	ı	ı	ı	ı
8		(8	H	X	Y	~	h	Å	á	ı	ı	ı	ı	ı	ı
9)	9	I	Y	Z	~	i	Å	á	ı	ı	ı	ı	ı	ı
A		*		J	Z	[~	j	Å	á	ı	ı	ı	ı	ı	ı
B		+	;	K	[]	~	k	Å	á	ı	ı	ı	ı	ı	ı
C		,	<	L	\]	~	l	Å	á	ı	ı	ı	ı	ı	ı
D		-	=	M]	^	~	m	Å	á	ı	ı	ı	ı	ı	ı
E		.	>	N	^	_	~	n	Å	á	ı	ı	ı	ı	ı	ı
F		/	?	O	_		~	o	Å	á	ı	ı	ı	ı	ı	ı

ISO-LTN (ISO Latin)

L/H	0	1	2	3	4	5	6	7	8	9	A	B	C	D	E	F
0					@	P	~	p								
1		!	1	A	Q	R	~	a								
2		"	2	B	R	S	~	b								
3	♥	#	3	C	S	T	~	c								
4	♦	\$	4	D	T	U	~	d								
5	♣	%	5	E	F	V	~	e								
6	♠	&	6	F	V	W	~	f								
7		'	7	G	W	X	~	g								
8		(8	H	X	Y	~	h								
9)	9	I	Y	Z	~	i								
A		*		J	Z	[~	j								
B		+	;	K	[]	~	k								
C		,	<	L	\]	~	l								
D		-	=	M]	^	~	m								
E		.	>	N	^	_	~	n								
F		/	?	O	_		~	o								

LATIN-P (Latin Polish)

L/H	0	1	2	3	4	5	6	7	8	9	A	B	C	D	E	F
0					@	P	~	p	Ç	É	á	ı	ı	ı	ı	ı
1		!	1	A	Q	R	~	a	Ç	É	ı	ı	ı	ı	ı	ı
2		"	2	B	R	S	~	b	Ç	É	ı	ı	ı	ı	ı	ı
3	♥	#	3	C	S	T	~	c	Ç	É	ı	ı	ı	ı	ı	ı
4	♦	\$	4	D	T	U	~	d	Ç	É	ı	ı	ı	ı	ı	ı
5	♣	%	5	E	F	V	~	e	Ç	É	ı	ı	ı	ı	ı	ı
6	♠	&	6	F	V	W	~	f	Ç	É	ı	ı	ı	ı	ı	ı
7		'	7	G	W	X	~	g	Ç	É	ı	ı	ı	ı	ı	ı
8		(8	H	X	Y	~	h	Ç	É	ı	ı	ı	ı	ı	ı
9)	9	I	Y	Z	~	i	Ç	É	ı	ı	ı	ı	ı	ı
A		*		J	Z	[~	j	Ç	É	ı	ı	ı	ı	ı	ı
B		+	;	K	[]	~	k	Ç	É	ı	ı	ı	ı	ı	ı
C		,	<	L	\]	~	l	Ç	É	ı	ı	ı	ı	ı	ı
D		-	=	M]	^	~	m	Ç	É	ı	ı	ı	ı	ı	ı
E		.	>	N	^	_	~	n	Ç	É	ı	ı	ı	ı	ı	ı
F		/	?	O	_		~	o	Ç	É	ı	ı	ı	ı	ı	ı

CHARACTER SETS

FINNISH (Finnish)

L/H	0	1	2	3	4	5	6	7	8	9	A	B	C	D	E	F
0																
1		!	"	#	\$	%	&	'	()	*	+	,	<	=	>
2		!	"	#	\$	%	&	'	()	*	+	,	<	=	>
3		!	"	#	\$	%	&	'	()	*	+	,	<	=	>
4		!	"	#	\$	%	&	'	()	*	+	,	<	=	>
5		!	"	#	\$	%	&	'	()	*	+	,	<	=	>
6		!	"	#	\$	%	&	'	()	*	+	,	<	=	>
7		!	"	#	\$	%	&	'	()	*	+	,	<	=	>
8		!	"	#	\$	%	&	'	()	*	+	,	<	=	>
9		!	"	#	\$	%	&	'	()	*	+	,	<	=	>
A		!	"	#	\$	%	&	'	()	*	+	,	<	=	>
B		!	"	#	\$	%	&	'	()	*	+	,	<	=	>
C		!	"	#	\$	%	&	'	()	*	+	,	<	=	>
D		!	"	#	\$	%	&	'	()	*	+	,	<	=	>
E		!	"	#	\$	%	&	'	()	*	+	,	<	=	>
F		!	"	#	\$	%	&	'	()	*	+	,	<	=	>

DANISH2 (Danish2)

L/H	0	1	2	3	4	5	6	7	8	9	A	B	C	D	E	F
0																
1		!	"	#	\$	%	&	'	()	*	+	,	<	=	>
2		!	"	#	\$	%	&	'	()	*	+	,	<	=	>
3		!	"	#	\$	%	&	'	()	*	+	,	<	=	>
4		!	"	#	\$	%	&	'	()	*	+	,	<	=	>
5		!	"	#	\$	%	&	'	()	*	+	,	<	=	>
6		!	"	#	\$	%	&	'	()	*	+	,	<	=	>
7		!	"	#	\$	%	&	'	()	*	+	,	<	=	>
8		!	"	#	\$	%	&	'	()	*	+	,	<	=	>
9		!	"	#	\$	%	&	'	()	*	+	,	<	=	>
A		!	"	#	\$	%	&	'	()	*	+	,	<	=	>
B		!	"	#	\$	%	&	'	()	*	+	,	<	=	>
C		!	"	#	\$	%	&	'	()	*	+	,	<	=	>
D		!	"	#	\$	%	&	'	()	*	+	,	<	=	>
E		!	"	#	\$	%	&	'	()	*	+	,	<	=	>
F		!	"	#	\$	%	&	'	()	*	+	,	<	=	>

National Character Sets (LQ-2500/LQ-2550 Emulation)

The following three pages show characters different from the graphics character sets available in the Epson LQ-2500/LQ-2550 emulation.

DANISH1 (Danish1)

L/H	0	1	2	3	4	5	6	7	8	9	A	B	C	D	E	F
0																
1		!	"	#	\$	%	&	'	()	*	+	,	<	=	>
2		!	"	#	\$	%	&	'	()	*	+	,	<	=	>
3		!	"	#	\$	%	&	'	()	*	+	,	<	=	>
4		!	"	#	\$	%	&	'	()	*	+	,	<	=	>
5		!	"	#	\$	%	&	'	()	*	+	,	<	=	>
6		!	"	#	\$	%	&	'	()	*	+	,	<	=	>
7		!	"	#	\$	%	&	'	()	*	+	,	<	=	>
8		!	"	#	\$	%	&	'	()	*	+	,	<	=	>
9		!	"	#	\$	%	&	'	()	*	+	,	<	=	>
A		!	"	#	\$	%	&	'	()	*	+	,	<	=	>
B		!	"	#	\$	%	&	'	()	*	+	,	<	=	>
C		!	"	#	\$	%	&	'	()	*	+	,	<	=	>
D		!	"	#	\$	%	&	'	()	*	+	,	<	=	>
E		!	"	#	\$	%	&	'	()	*	+	,	<	=	>
F		!	"	#	\$	%	&	'	()	*	+	,	<	=	>

ITALIAN (Italian)

L/H	0	1	2	3	4	5	6	7	8	9	A	B	C	D	E	F
0																
1		!	"	#	\$	%	&	'	()	*	+	,	<	=	>
2		!	"	#	\$	%	&	'	()	*	+	,	<	=	>
3		!	"	#	\$	%	&	'	()	*	+	,	<	=	>
4		!	"	#	\$	%	&	'	()	*	+	,	<	=	>
5		!	"	#	\$	%	&	'	()	*	+	,	<	=	>
6		!	"	#	\$	%	&	'	()	*	+	,	<	=	>
7		!	"	#	\$	%	&	'	()	*	+	,	<	=	>
8		!	"	#	\$	%	&	'	()	*	+	,	<	=	>
9		!	"	#	\$	%	&	'	()	*	+	,	<	=	>
A		!	"	#	\$	%	&	'	()	*	+	,	<	=	>
B		!	"	#	\$	%	&	'	()	*	+	,	<	=	>
C		!	"	#	\$	%	&	'	()	*	+	,	<	=	>
D		!	"	#	\$	%	&	'	()	*	+	,	<	=	>
E		!	"	#	\$	%	&	'	()	*	+	,	<	=	>
F		!	"	#	\$	%	&	'	()	*	+	,	<	=	>

CHARACTER SETS

LATIN A (Latin American)

L/H	0	1	2	3	4	5	6	7	8	9	A	B	C	D	E	F
0				à	á	â	ã	ä	å	æ	ç	è	é	ê	ë	ñ
1	!	"	#	\$	%	&	'	()	*	+	,	<	=	>	?
2		À	Á	Â	Ã	Ä	Å	Æ	Ç	È	É	Ê	Ë	Ë	Ë	Ñ
3		à	á	â	ã	ä	å	æ	ç	è	é	ê	ë	ë	ë	ñ
4		À	Á	Â	Ã	Ä	Å	Æ	Ç	È	É	Ê	Ë	Ë	Ë	Ñ
5		à	á	â	ã	ä	å	æ	ç	è	é	ê	ë	ë	ë	ñ
6		À	Á	Â	Ã	Ä	Å	Æ	Ç	È	É	Ê	Ë	Ë	Ë	Ñ
7		à	á	â	ã	ä	å	æ	ç	è	é	ê	ë	ë	ë	ñ
8		À	Á	Â	Ã	Ä	Å	Æ	Ç	È	É	Ê	Ë	Ë	Ë	Ñ
9		à	á	â	ã	ä	å	æ	ç	è	é	ê	ë	ë	ë	ñ
A		À	Á	Â	Ã	Ä	Å	Æ	Ç	È	É	Ê	Ë	Ë	Ë	Ñ
B		à	á	â	ã	ä	å	æ	ç	è	é	ê	ë	ë	ë	ñ
C		À	Á	Â	Ã	Ä	Å	Æ	Ç	È	É	Ê	Ë	Ë	Ë	Ñ
D		à	á	â	ã	ä	å	æ	ç	è	é	ê	ë	ë	ë	ñ
E		À	Á	Â	Ã	Ä	Å	Æ	Ç	È	É	Ê	Ë	Ë	Ë	Ñ
F		à	á	â	ã	ä	å	æ	ç	è	é	ê	ë	ë	ë	ñ

DANISH2 (Danish2)

L/H	0	1	2	3	4	5	6	7	8	9	A	B	C	D	E	F
0				à	á	â	ã	ä	å	æ	ç	è	é	ê	ë	ñ
1	!	"	#	\$	%	&	'	()	*	+	,	<	=	>	?
2		À	Á	Â	Ã	Ä	Å	Æ	Ç	È	É	Ê	Ë	Ë	Ë	Ñ
3		à	á	â	ã	ä	å	æ	ç	è	é	ê	ë	ë	ë	Ñ
4		À	Á	Â	Ã	Ä	Å	Æ	Ç	È	É	Ê	Ë	Ë	Ë	Ñ
5		à	á	â	ã	ä	å	æ	ç	è	é	ê	ë	ë	ë	Ñ
6		À	Á	Â	Ã	Ä	Å	Æ	Ç	È	É	Ê	Ë	Ë	Ë	Ñ
7		à	á	â	ã	ä	å	æ	ç	è	é	ê	ë	ë	ë	Ñ
8		À	Á	Â	Ã	Ä	Å	Æ	Ç	È	É	Ê	Ë	Ë	Ë	Ñ
9		à	á	â	ã	ä	å	æ	ç	è	é	ê	ë	ë	ë	Ñ
A		À	Á	Â	Ã	Ä	Å	Æ	Ç	È	É	Ê	Ë	Ë	Ë	Ñ
B		à	á	â	ã	ä	å	æ	ç	è	é	ê	ë	ë	ë	Ñ
C		À	Á	Â	Ã	Ä	Å	Æ	Ç	È	É	Ê	Ë	Ë	Ë	Ñ
D		à	á	â	ã	ä	å	æ	ç	è	é	ê	ë	ë	ë	Ñ
E		À	Á	Â	Ã	Ä	Å	Æ	Ç	È	É	Ê	Ë	Ë	Ë	Ñ
F		à	á	â	ã	ä	å	æ	ç	è	é	ê	ë	ë	ë	Ñ

FRENCH (French)

L/H	0	1	2	3	4	5	6	7	8	9	A	B	C	D	E	F
0				à	á	â	ã	ä	å	æ	ç	è	é	ê	ë	ñ
1	!	"	#	\$	%	&	'	()	*	+	,	<	=	>	?
2		À	Á	Â	Ã	Ä	Å	Æ	Ç	È	É	Ê	Ë	Ë	Ë	Ñ
3		à	á	â	ã	ä	å	æ	ç	è	é	ê	ë	ë	ë	Ñ
4		À	Á	Â	Ã	Ä	Å	Æ	Ç	È	É	Ê	Ë	Ë	Ë	Ñ
5		à	á	â	ã	ä	å	æ	ç	è	é	ê	ë	ë	ë	Ñ
6		À	Á	Â	Ã	Ä	Å	Æ	Ç	È	É	Ê	Ë	Ë	Ë	Ñ
7		à	á	â	ã	ä	å	æ	ç	è	é	ê	ë	ë	ë	Ñ
8		À	Á	Â	Ã	Ä	Å	Æ	Ç	È	É	Ê	Ë	Ë	Ë	Ñ
9		à	á	â	ã	ä	å	æ	ç	è	é	ê	ë	ë	ë	Ñ
A		À	Á	Â	Ã	Ä	Å	Æ	Ç	È	É	Ê	Ë	Ë	Ë	Ñ
B		à	á	â	ã	ä	å	æ	ç	è	é	ê	ë	ë	ë	Ñ
C		À	Á	Â	Ã	Ä	Å	Æ	Ç	È	É	Ê	Ë	Ë	Ë	Ñ
D		à	á	â	ã	ä	å	æ	ç	è	é	ê	ë	ë	ë	Ñ
E		À	Á	Â	Ã	Ä	Å	Æ	Ç	È	É	Ê	Ë	Ë	Ë	Ñ
F		à	á	â	ã	ä	å	æ	ç	è	é	ê	ë	ë	ë	Ñ

National Character Sets and Supported Resident Fonts (All Emulations)

In all emulations, this printer supports 37 national character sets for characters and symbols specific to different languages. Some national character sets, however, do not have specific characters and symbols and may not be usable depending on resident fonts. The following tables show which of the resident fonts are supported for each national character set:

Resident fonts		Courier	Elite 12	Compress	Draft	Bold PS	Pica 10	Correspond	H-draft	Dutch N	Dutch I	Dutch B	Swiss N	Swiss I	Swiss B	OCR-B
National character sets	Names in setup menu															
USA *	USA	√	√	√	√	√	√	√	√	√	√	√	√	√	√	√
United Kingdom	UK	√	√	√	√	√	√	√	√	√	√	√	√	√	√	√
German	GERMAN	√	√	√	√	√	√	√	√	√	√	√	√	√	√	√
Swedish	SWEDISH	√	√	√	√	√	√	√	√	√	√	√	√	√	√	√
ISO 8859-1	ISO8859	√	√	√	√	√	√	√	√	√	√	√	√	√	√	√
ECMA 94	ECMA94	√	√	√	√	√	√	√	√	√	√	√	√	√	√	√
Code Page 437 *	PAGE437	√	√	√	√	√	√	√	√	√	√	√	√	√	√	√
Code Page 850	PAGE850	√	√	√	√	√	√	√	√	√	√	√	√	√	√	√
Code Page 852	PG852	√	√	√	√	√	√									
" two-pass	PG852-T	√	√	√	√	√	√									
Code Page 855	PG855	√	√	√	√											
Code Page 860	PAGE860	√	√	√	√	√	√	√	√	√	√	√	√	√	√	√
Code Page 863	PAGE863	√	√	√	√	√	√	√	√	√	√	√	√	√	√	√
Code Page 865	PAGE865	√	√	√	√	√	√	√	√	√	√	√	√	√	√	√
Code Page 866	PG866	√	√	√	√											

* USA is the same as Code Page 437.

√: Supported

N: normal, I: italic, B: bold

H-draft: high-speed draft

Correspond: correspondence

(Continued to the next page)

Resident fonts		Courier	Elite 12	Compress	Draft	Bold PS	Pica 10	Correspond	H-draft	Dutch N	Dutch I	Dutch B	Swiss N	Swiss I	Swiss B	OCR-B
National character sets	Names in setup menu															
Hungarian	HUNGARY	√	√	√	√	√	√									
" two-pass	HUNG-T	√	√	√	√	√	√									
Slovenian	SLOV	√	√	√	√	√	√	√	√	√	√	√	√	√	√	√
" two-pass	SLOV-T	√	√	√	√	√	√									
Polish	POLISH	√	√	√	√	√	√									
" two-pass	POLSH-T	√	√	√	√	√	√									
Mazovian	MAZOWIA	√	√	√	√	√	√									
" two-pass	MAZOW-T	√	√	√	√	√	√									
Latin 7	LATIN7	√	√	√	√											
Latin 2	LATIN2	√	√	√	√	√	√									
" two-pass	LATN2-T	√	√	√	√	√	√									
Kamenicky	KAMENIC	√	√	√	√	√	√									
" two-pass	KAMEN-T	√	√	√	√	√	√									
Turkish	TURKY	√	√	√	√	√	√									
" two-pass	TURKY-T	√	√	√	√	√	√									
Cyrillic	CYRILIC	√	√	√	√											
IBM 437	IBM437	√	√	√	√											
IBM 851	IBM851	√	√	√	√											
ELOT 928	ELOT928	√	√	√	√											
Code Page DHN	PG-DHN	√	√	√	√	√	√									
Latin Polish	LATIN-P	√	√	√	√	√	√									
ISO Latin	ISO-LTN	√	√	√	√	√	√									

√: Supported
 N: normal, I: italic, B: bold
 H-draft: high-speed draft
 Correspond: correspondence

INDEX

A

Adjustments

- paper select lever 2-9, 3-3
 - paper thickness lever 2-9, 3-3
 - top-of-form 2-13, 5-36
- AGM (Alternate Graphics Mode) 5-23, 5-52
- ATTRIB 5-18
- Attributes, font 5-18

B

- Bidirectional printing 5-29
- Bold face 5-15
- BUFFER 5-30
- Buffer size 5-30
- Buttons
- FONT SELECT 4-2
 - LF/FF 3-2, 4-2, 5-6
 - LOAD/UNLOAD 3-3, 3-7, 3-11, 3-17
 - MENU SELECT 4-2
 - MODE 3-2, 4-2, 5-6
 - ONLINE 2-22, 5-7
 - TEAR OFF 3-3, 3-17
- BUZZER 5-29

C

Cables

- parallel (Centronics) 2-17, D-1
 - serial (RS-232C) 2-17, D-4
- Carriage return (CR) 5-24

- missing 7-3
- Centronics (parallel) interface
- cable connection 2-18
 - specifications D-1
- Change ribbon cartridge 6-3
- Character
- enlargement 5-17, 5-18
 - height 5-18
 - pitch 5-17
 - sets 5-23, E-1
 - width 5-17
- CHAR-H 5-18
- CHAR-W 5-17
- CHR-SET 5-23
- Cleaning 6-1
- Clear print buffer 4-8
- COLOR 5-19
- Color
- kit, installing 8-2
 - ribbon 2-7, 6-5
 - selecting 5-14, 5-19
- Command sets, resident C-1
- Compressed font 5-15
- Condensed printing 5-18
- Continuous forms
- loading 3-13
 - placement 3-12
 - tearing off 3-17
 - unloading 3-17
- Control panel 2-9, 3-2, 4-2
- Correspondence 5-15
- Courier 10 5-15
- CR-CODE 5-24
- Cursor, on print guide 2-21, 5-4

Cut sheet feeder
 installing 8-1
 loading 3-8
 Cut sheet stand
 installing 2-5
 loading 2-12, 3-5

D

DC1/DC3 commands 5-24
 DC3-CDE 5-24
 DEFAULT function 5-27, 5-42
 Default settings
 factory defaults 5-11
 resetting 5-41
 resetting MENU1 and MENU2 5-41
 power-on defaults 5-1
 resetting 5-40
 Demo pattern 2-16
 Diagnostic functions 5-42, 7-8
 Download buffer 5-30
 Download (soft) fonts 4-1, 5-16
 DPL24C PLUS
 commands C-1
 factory defaults C-14
 selecting 2-19, 5-15
 DRAFT 5-16
 DTR protocol 5-32, D-8

E

Ejecting single sheets C-12, C-21, C-27
 EMULATE 2-21, 5-12, 5-15
 Emulations
 selecting 2-19, 5-12, 5-14
 supported 2-19

Entering setup mode 5-2
 Envelope adapter 3-21, 8-1
 Envelopes, using 3-21
 Epson LQ-2500/LQ-2550
 commands C-22
 selecting 2-19, 5-15
 ETX/ACK protocol 5-32, D-8
 Exiting setup mode 5-39

F

Factory Default Settings C-14
 Factory settings (defaults) 5-11, 5-41
 FEEDER 5-30
 Feeder type, selecting 5-13, 5-30, 8-2
 Feeding paper
 form feed 3-3, 3-19
 line feed 3-3, 3-19
 problems 7-4
 FF button 3-2, 4-2, 5-6
 FONT SELECT 4-5, 5-15
 Fonts
 attributes 5-18
 selecting 5-15
 types 1-2, F-1
 Form feed 3-3, 3-19
 Forms tractors 2-10, 3-15
 Fujitsu DPL24C PLUS
 selecting 2-19, 5-15
 <<FUNCTION>> menu 5-3
 Functions
 DEFAULT 5-27, 5-42
 HARDWRE 5-28
 HEX-DUMP 5-44, 7-8
 LIST 5-10
 MENU1 5-14
 MENU2 5-14

purpose 5-4
 SAVE&END 5-39
 selecting 5-5
 SELF-TST 5-42, 7-8
 TOF-ADJ 5-36
 V-ALMNT 5-46, 7-8

G-H

Glossary of terms GL-1
 Hardware (options)
 in setup mode 5-28
 installing 8-1
 order numbers A-1
 HARDWRE function 5-28
 Help menus 5-4, 5-9
 Help, where to get 7-8
 HEX-DUMP function 5-44, 7-8
 HI-DRFT 5-16

I

IBM Proprinter XL24
 commands C-17
 selecting 2-19, 5-15
 Indicators 2-11
 Installing
 color kit 8-7
 cut sheet feeder 8-1
 cut sheet stand 2-5
 forms paper 3-16
 interface cable 2-18
 power cord 2-10
 printer head 6-7
 ribbon cartridge 2-6, 6-3
 Italics 5-18

Items, setup
 HARDWRE 5-28
 MENU1 5-14
 MENU2 5-14
 TOF-ADJ 5-36

L

Labels, using 3-20
 LANGUAGE 5-21
 Lever
 bin 3-9
 paper select 3-2
 paper thickness 3-2, 3-4
 tractor locking 3-14
 LF button 3-2, 4-2, 5-7
 LF-CODE 5-25
 LFT-END 5-20
 Line feed 3-3, 3-19
 LINE SP 5-17
 Line spacing 5-17
 LIST function 5-10
 LOAD/UNLOAD button 3-3, 3-7, 3-11, 3-17
 Loading
 continuous forms 3-13
 cut sheet feeder 3-8
 single sheets 3-5
 Lubrication, printer 6-1

M

Maintenance, printer 6-1
 Margins
 checking 3-7, 3-11, 3-16
 left 5-20
 top 5-20

MENU1 function 5-14

MENU1 and MENU2

- changing options (setup mode) 5-14
- on control panel 4-2
- switching between 4-3

MENU2 function 5-14

Menu, <<FUNCTION>> 2-20, 5-4

MENU SELECT 4-3, 5-12

Multi-part paper 3-20, B-7

N

Nameplate, printer 2-10

National character sets

- all emulations E-4
- DPL24C PLUS/IBM XL24 E-11
- LQ-2500/-2550 E-12

Number of copies 3-1, B-2

O

ONLINE

- button 2-22, 5-7
- indicator 2-11

Online setup 5-53

Options, hardware 1-2

- installing 8-1
- order numbers A-1

Options, setup

- currently selected 5-10
- hardware 5-28
- MENU 1 5-14
- MENU 2 5-14
- required 5-12
- top-of-form 5-36

P

Page

- length 3-1, 5-19
- width 3-1, 5-24

PAGE LG 5-19

Paper

- continuous forms 3-13
- ejecting single sheets 3-11
- feeding 3-19
- guides 3-6, 3-9
- loading 3-5, 3-8, 3-13
- operations 3-2
- print areas B-5
- selection 3-1, B-5
- select lever 3-2
- single sheets 3-5
- size and thickness 3-1, B-5
- specifications 3-1, B-5
- thickness lever 3-4
- tips for handling 3-20
- types, switching 3-19
- unloading forms 3-17

Paper-out detection 4-6, 5-28

PAPER OUT indicator 2-11, 3-19, 4-6

Paper-out sensor 3-9, 7-4

Paper path

- selecting 3-3
- switching 3-19

Parallel (Centronics) interface

- cable connection 2-18
- specifications D-1

Perforation skip 5-23

Pica 10 5-15

PITCH 5-17

Pitch, selecting in setup mode 5-17

Platen 2-9

- cleaning 6-2
- knob 2-4

Power
connector 2-10
cord 2-2, 2-10
switch 2-10
Power-on defaults 5-40
PPR-OUT 5-28
Prestige Elite 12 5-15
PRF-SKIP 5-23
Print
areas B-5
buffer, clearing 4-8, 5-30
features, selecting 4-1
list of selected options 5-10
Print head carriage 2-6, 6-3
Printer
control panel 2-9, 3-2, 4-2
failures 7-7
features 1-1
location 2-1
normal mode QR-1, 5-1
options 1-2, 8-1
parts 2-9
performance B-4
problems 7-1
setup 2-1
setup mode 5-1
specifications B-1
Stand 3-12
Printing
currently selected options 5-10
demo pattern 2-16
in hexadecimal 5-44
problems 7-2
self-test 2-13, 5-42
start 4-6
stop 4-6
using control panel 4-2

using software 4-2
with parallel interface 2-22
with serial interface 2-22

Problems
operational 7-6
paper handling 7-4
power 7-6
printer failures 7-7
printing 7-1
solving 7-1
Protocols, serial 5-32, D-7
PRT-DIR 5-29
Publications A-2

Q

QUALITY 5-16
Quick Reference, operation QR-1

R

RC protocol 5-32, D-8
Removing printed pages 4-7
Replacing ribbon cartridge 6-3
Reset defaults 5-40
Resident
command sets C-1
emulations 2-19, 5-15
fonts 1-2, 4-5, F-1
Resident Fonts F-1
Resume printing 4-6
RGHTEND 5-25
Ribbon cartridge
installing 2-6
replacing 6-3

Index

RS-232C (serial) interface	
cable connection	2-18
optional settings (setup)	2-23, 5-30
specifications	D-4

S

SAVE&END function	5-39
Saving settings	5-8, 5-39
Select (DC1)/Deselect (DC3) commands	5-24
Self-test, printer	2-13, 5-42
SELF-TST function	5-42
Serial (RS-232C) interface	
cable connection	2-18
optional settings (setup)	2-23, 5-30
specifications	D-4
Setup mode	
changing hardware options	5-28
changing MENU 1 and 2 options	5-14
changing top-of-form	5-36
DPL24C PLUS flowchart	5-50
entering	5-2
example	5-6
exiting	5-39
online	5-53
overview of	5-4
saving settings	5-39
summary of buttons	5-7
Setup options	
Alternate Graphics Mode (AGM)	5-23
attributes (ATTRIB)	5-18
buffer (BUFFER)	5-30
buzzer ON/OFF (BUZZER)	5-29
carriage return (CR)	5-24
character height (CHAR-H)	5-18
character set (CHR-SET)	5-23
character width (CHAR-W)	5-17
color (COLOR)	5-19
complete listing	5-10
emulation (EMULATE)	5-15
feeder type (FEEDER)	5-30
fonts (FONT)	5-15
hardware options	5-28
language (LANGUGE)	5-21
left end of page (LFT-END)	5-20
line feed (LF)	5-25
line spacing (LINE SP)	5-17
MENU 1 and MENU 2 options	5-14
page length (PAGE LG)	5-19
page width (WIDTH)	5-24
paper-out response (PPR-OUT)	5-28
perforation skip (PRF-SKIP)	5-23
pitch	5-17
print direction (PRT-DIR)	5-29
print options	5-16
print quality	5-16
right end of page (RGHTEND)	5-25
Select/Deselect commands (DC3-CDE)	5-24
serial options	5-30
tear-off (TEAROFF)	5-32
tear-off enable time (TEAR-EN)	5-33
tear-off position (TEARPOS)	5-33
top margin (TOP-MRG)	5-20
top-of-form	5-36
word length (WORD-LG)	5-29
zero with a slash (ZEROFNT)	5-24
Shadow printing	5-18
Shipping restraint	2-3
Single sheets	
ejecting	3-11
loading	3-5, 3-8
Soft (download) fonts	4-1, 5-15
Software, using	2-22, 4-2

Specifications	
interface	D-1
paper	B-5
printer	B-1
Supplies	A-1
Switching	
MENU1 and MENU2	4-5
menu font and resident font	4-3
paper types	3-19

T

Tearing off forms	3-17
Tear-off setup options	5-32
Testing printer	
offline	2-12, 5-42
online	2-22
TOF-ADJ function	5-36
Top margin, changing	2-13, 5-20
TOP-MRG	5-20
Top-of-form, changing	5-36
Tractors, positioning	3-15

U-Z

Unidirectional printing	5-29
Unpacking	2-2
V-ALMNT function	5-46, 7-8
Vertical character displacement	
correcting	5-46, 7-8
WIDTH	5-24
Word length	5-29
WORD-LG	5-29
XON/XOFF protocol	5-51, D-8
ZEROFNT	5-24

INDEX

RESIDENT FONTS

COURIER 10

The 24-wire dot-matrix printer prints quality characters and symbols using a variety of sizes and fonts.

PRESTIGE ELITE 12

The 24-wire dot-matrix printer prints quality characters and symbols using a variety of sizes and fonts.

DRAFT

The 24-wire dot-matrix printer prints quality characters and symbols using a variety of sizes and fonts.

COMPRESSION

The 24-wire dot-matrix printer prints quality characters and symbols using a variety of sizes and fonts.

PICA 10

The 24-wire dot-matrix printer prints quality characters and symbols using a variety of sizes and fonts.

CORRESPONDENCE

The 24-wire dot-matrix printer prints quality characters and symbols using a variety of sizes and fonts.

HIGH-SPEED DRAFT

The 24-wire dot-matrix printer prints quality characters and symbols using a variety of sizes and fonts.

BOLDFACE PS

The 24-wire dot-matrix printer prints quality characters and symbols using a variety of sizes and fonts.

DUTCH 801 Normal

The 24-wire dot-matrix printer prints quality characters and symbols using a variety of sizes and fonts.

DUTCH 801 Italic

The 24-wire dot-matrix printer prints quality characters and symbols using a variety of sizes and fonts.

DUTCH 801 Bold

The 24-wire dot-matrix printer prints quality characters and symbols using a variety of sizes and fonts.

SWISS 721 Normal

The 24-wire dot-matrix printer prints quality characters and symbols using a variety of sizes and fonts.

SWISS 721 Italic

The 24-wire dot-matrix printer prints quality characters and symbols using a variety of sizes and fonts.

SWISS 721 Bold

The 24-wire dot-matrix printer prints quality characters and symbols using a variety of sizes and fonts.

OCR-B

The 24-wire dot-matrix printer prints quality characters and symbols using a variety of sizes and fonts.

GLOSSARY OF TERMS

A4 size	A standard paper size used in Japan and other countries. Paper is 210 x 295 mm (8.25 x 11.6 inches).
Application software	Software programs that perform tasks such as word processing, database management, or accounting on a computer.
ASCII	The acronym for American Standard Code for Information Interchange. ASCII is a set of 256 codes (numbered 0 to 255) used to communicate information between a computer and another device such as a printer.
Baud rate	The speed, in bits per second, at which data is transmitted to a device such as a printer. Baud rates apply to serial data only. 1200 baud equals approximately 120 characters per second.
Bidirectional printing	Alternately printing lines from left to right and right to left. Bidirectional printing is faster than unidirectional printing because there are no carriage returns.
Bit	The smallest unit of information in computer memory. A bit is a single digit, either a 1 or a 0, in the binary numbering system. Eight bits equal one byte.
Buffer	A storage area for data in the printer or computer. The printer's buffer consists of a print buffer and a download buffer. The print buffer holds data to be printed. The download buffer holds downloaded data such as download (soft) fonts.
Byte	Eight bits that constitute one symbol. A byte represents a single character such as a number, a letter, or a special control character.
Carriage return (CR)	The return of the print head carriage to the beginning of the next line.
Centronics interface	A type of parallel interface. See Parallel interface .

Column	A vertical section on a printed page. This printer can print 136-column pages at 10-pitch (10 characters per inch).
Command set	A set of print and format commands used to control the printer. Each printer has its own resident command sets embedded in the printer firmware, and they are actuated by codes sent from the host computer.
Condensed print	Print that uses "condensed" characters. Condensed characters have a decreased width. Using condensed print increases the number of characters per line.
Continuous forms	Connected fan-folded sheets of paper fed into the printer using forms tractors. The fan-folded sheets are separated by tearing them at their perforations.
Control panel	A panel containing the printer's indicators and buttons. The control panel is used to control printer operations such as loading paper, selecting print features, and changing setup options.
cpi	Characters per horizontal inch. Also referred to as pitch. For example, 12-pitch means 12 cpi.
cps	Characters per second.
Cut sheets	See Single sheets .
Cut sheet feeder	An option that replaces the cut sheet stand. It allows automatic loading from a stack of paper.
Defaults	Settings automatically selected by the printer when power is turned on. By entering setup mode, you can change the defaults to ensure compatibility with your system hardware and software.
Dot matrix	The grid used to print characters on a dot matrix printer. Each dot corresponds to a wire in the print head.
Downloading	Transferring soft fonts from the computer to the printer's memory. Downloading allows you to use fonts not resident in the computer.

dpi	Dots per inch.
Emulation	A command set that allows one printer to print like another printer. This printer has three resident emulations in addition to its native command set: IBM proprinter XL24, Epson LQ-2500, and Epson LQ-2550.
Font	A complete set of printable characters all having the same size and style. For example, Courier 10 and Prestige Elite 12 are commonly used fonts.
Form feed (FF)	A signal to the printer to advance the paper forward one page. Form feeds can be executed either using software or holding the LF/FF button down on the printer's control panel.
Graphics printing	Controlling the print head wires (dots) individually to produce a picture or an image on the page.
Hexadecimal	A base-16 numbering system (also commonly referred to as hex numbers). Since a base-16 system requires 16 digits, numbers 0 through 9 and letters A through F are used. It is convenient to express binary numbers in hexadecimal because fewer digits are required.
Hex dump	A hexadecimal printout of control codes and data. Hex dumps are used to debug computer programs and to troubleshoot printer malfunctions. To print a hex dump using the printer, you can use the HEX-DUMP function in setup mode.
Interface	The connection that allows communication from one part of a system to another. For example, electrical signals are transferred between the computer and printer over an interface cable.
Kb	Kilobyte. 1 Kb equals 1024 bytes.
Letter size	A standard paper size used in the U.S.A. and other countries. Paper is 8-1/2 x 11 inches (215.9 x 279.4 mm).

Line feed (LF)	A signal to the printer that advances the paper forward one line. Line feeds can be executed either using software or touching the LF/FF button on the printer's control panel.
Line spacing	The vertical spacing between lines, measured in lines per inch.
lpi	Lines per inch. Used to measure line spacing.
Monospacing	Character spacing in which each printed character has the same width. Also called fixed pitch, monospacing is the opposite of proportional spacing. Typewriter or computer-printed text is typically monospaced.
Non-resident fonts	Fonts not present (resident) in the printer's permanent memory. This includes soft fonts and fonts on font cards.
Normal mode	One of the printer's two operating modes. In normal mode, the control panel can be used to perform everyday printer operations such as loading and unloading paper, feeding paper, and selecting print features. See also Setup mode .
Offline	When the printer is offline, it receives commands from the printer's control panel instead of the computer. It indicates that the printer is not "online" with the computer.
Online	When the printer is online, it is ready to receive or is receiving commands from the computer. The printer must be online to print.
Parallel interface	A standard computer interface. Information is transferred between devices over separate wires, allowing all of the bits that make up the character to be transmitted simultaneously (in parallel).
Park position	The position in which continuous forms paper is retracted or "parked" on the rear forms tractors. When the forms paper is loaded, it moves forward from the park position onto the platen.
Permanent memory	Memory that retains information even if the power is turned off. The printer's permanent memory retains the default settings that are specified using the printer's setup mode.

Pitch	Characters per horizontal inch (cpi).
Platen	A hard rubber cylinder that moves paper forward during printing.
Proportional spacing	Character spacing in which wide characters occupy more space than narrow characters. For example, characters such as "W" or "M" occupy more space than characters such as "i" or "l." Many soft fonts are proportionally spaced. Sometimes abbreviated PS, proportional spacing is the opposite of monospacing.
Protocol	A set of instructions that control the way data is transmitted between devices such as a computer and printer.
Resident fonts	Fonts present (resident) in the printer's permanent memory. For this printer, the resident fonts are Courier 10, Prestige Elite 12, Pica 10, Boldface PS, Compressed font, Correspondence, and Draft. Unlike soft fonts, resident fonts can always be accessed.
RS-232C interface	A type of serial interface. See Serial interface .
Self-test	A test to determine whether the printer is working correctly. Test pages are printed to show print quality and whether all characters print. The self-test only tests the printer. It does not test how the computer works with the printer.
Serial interface	A standard computer interface. Information is transferred between devices over a single wire (although other wires are used for control). With a serial interface, an interface cable greater than 3 meters (10 feet) can be used. This is often necessary in networking environments, where the printer may be shared.
Setup mode	One of the printer's two operating modes. In setup mode, the control panel can be used to select the printer's default settings, such as print features, hardware options, and top-of-form. Setup mode also provides some diagnostic functions. See also Normal mode .
Shadow printing	Printing characters twice for emphasis. Characters printed the second time are shifted slightly to the right.

Single sheets	Sheets of paper, envelopes, and non-continuous multi-part forms fed into the printer using the cut sheet stand or optional cut sheet feeder. They are also sometimes called cut sheets.
Soft fonts	Fonts downloaded from a disk to the printer's memory. They are also referred to as download fonts. Unlike resident fonts, soft fonts are available only while in the printer's memory.
Software	Programs that control the computer and printer to perform specified tasks such as word processing, database management, and preparation of spreadsheets. Software is sometimes referred to as application software.
Top margin	The total space at the top of the printed page. The top margin is the sum of all of the following: the top-of-form setting, the software-specified top margin, and the printer's TOP-MRG setting.
Top-of-form (TOF)	The logical top of the physical page, as "understood" by the printer when loading paper. The default TOF settings for the printer are 1/6 of an inch (4.2 mm) or 1 inch (25.4 mm).
Tractor feed	A method for feeding continuous forms forward for printing. Holes on the sides of the forms fit over sprockets on two tractors inside the printer.
Unidirectional printing	Printing in one direction only, left to right. Printing is slower than with bidirectional printing, but the vertical alignment is more accurate. Unidirectional printing is useful when precise vertical alignment is required, as in ruled tables.

REGIONAL OFFICES

Address your comments and inquiries on this manual to:

FUJITSU COMPUTER PRODUCTS OF
AMERICA, INC.
2904 Orchard Parkway, San Jose
CA 95134-2022, U.S.A.
TEL: (1-408) 432-6333
FAX: (1-408) 894-1709

FUJITSU AUSTRALIA LIMITED
475 Victoria Avenue, Chatswood
N.S.W., 2067, AUSTRALIA
TEL: (61-2) 410-4555
FAX: (61-2) 411-8603
TLX: 25233

FUJITSU CANADA, INC.
2800 Matheson Boulevard East
Mississauga, Ontario L4W 4X5, CANADA
TEL: (1-416) 602-5454
FAX: (1-416) 602-5457

FUJITSU DEUTSCHLAND GmbH
Frankfurter Ring 211
8000, München 40, F.R. GERMANY
TEL: (49-89) 32378-0
FAX: (49-89) 32378-100
TLX: 897106

FUJITSU ESPAÑA, S.A.
Edificio Torre Europa 5ª
Paseo de la Castellana 95
28046 Madrid, SPAIN
TEL: (34-1) 581-8000
FAX: (34-1) 581-8300
TLX: 23887

FUJITSU EUROPE LIMITED
2, Longwalk Road, Stockley Park
Uxbridge, Middlesex UB11 1AB, ENGLAND
TEL: (44-81) 573-4444
FAX: (44-81) 573-2643
TLX: 263871

FUJITSU (SINGAPORE) PTE. LTD.
75 Science Park Drive
#02-06 CINTECH II, SINGAPORE 0511
TEL: (65) 777-6577
FAX: (65) 777-8794

TATUNG-FUJITSU CO., LTD.
5F Tatung Bldg., 225 Nanking East Road
3rd Sec. Taipei, TAIWAN
TEL: (886-2) 713-5396
FAX: (886-2) 717-4644

FUJITSU FRANCE S.A.
Batiment Aristote, Rue Olof Palme 94006
Creteil Cedex, FRANCE
TEL: (33-1) 43-99-4000
FAX: (33-1) 43-99-0700
TLX: 262 661

FUJITSU HONG KONG LIMITED
Room 2521, Sun Hung Kai Centre
30 Harbour Road, HONG KONG
TEL: (852) 827-5780
FAX: (852) 827-4724
TLX: 62667

FUJITSU ITALIA S.p.A.
Via Melchiorre, Gioia No. 8
20124 Milano, ITALY
TEL: (39-2) 657-2741
FAX: (39-2) 657-2257
TLX: 350142

FUJITSU NORDIC AB
Torggatan 8, S-171 54 Solna, SWEDEN
TEL: (46-8) 764-76 90
FAX: (46-8) 28-0345
TLX: 13411

FUJITSU LIMITED
International Operations
Marunouchi 1-6-1, Chiyoda-ku
Tokyo 100, JAPAN
TEL: (81-3) 3216-3211
FAX: (81-3) 3216-9353
TLX: J22833
Cable: "FUJITSU LIMITED TOKYO"

Free Manuals Download Website

<http://myh66.com>

<http://usermanuals.us>

<http://www.somanuals.com>

<http://www.4manuals.cc>

<http://www.manual-lib.com>

<http://www.404manual.com>

<http://www.luxmanual.com>

<http://aubethermostatmanual.com>

Golf course search by state

<http://golfingnear.com>

Email search by domain

<http://emailbydomain.com>

Auto manuals search

<http://auto.somanuals.com>

TV manuals search

<http://tv.somanuals.com>