

PRIMERGY BX600 S2 Basic Unit

Operating Manual

Edition March 2007

Comments... Suggestions... Corrections...

The User Documentation Department would like to know your opinion of this manual. Your feedback helps us optimize our documentation to suit your individual needs.

Feel free to send us your comments by e-mail to manuals@fujitsu-siemens.com.

Certified documentation according to DIN EN ISO 9001:2000

To ensure a consistently high quality standard and user-friendliness, this documentation was created to meet the regulations of a quality management system which complies with the requirements of the standard DIN EN ISO 9001:2000.

cognitas. Gesellschaft für Technik-Dokumentation mbH
www.cognitas.de

Copyright and Trademarks

Copyright © 2007 Fujitsu Siemens Computers GmbH.

All rights reserved.

Delivery subject to availability; right of technical modifications reserved.

All hardware and software names used are trademarks of their respective manufacturers.

Contents

1	Introduction	7
1.1	Overview of the Documentation	8
1.2	Features	10
1.3	Notational Conventions	14
1.4	Technical Data	15
2	Overview: Basic Unit Installation Steps	19
3	Important Notes	21
3.1	Notes on Safety	21
3.2	Components With Electrostatic-Sensitive Devices	25
3.3	CE Certificate	25
3.4	FCC Class A Compliance Statement	26
3.5	Transporting the Basic Unit	27
3.6	Notes on Installing in the Rack	28
3.7	Environmental Protection	29
4	Installing the Hardware	33
4.1	Installation Steps	33
4.2	Unpacking the Basic Unit	34
4.3	Installing the System in the Rack	35
4.3.1	Mounting the Assembly Kit	38
4.3.2	Mounting/Removing the Basic Unit	40
4.4	Connecting External Devices	41
4.4.1	Cable Routing	43
4.4.2	Instructions on Connecting and Disconnecting Cables	45
4.5	Connecting the System to the Mains	46

Contents

5	Preparation for Use and Operation	49
5.1	Operating and Indicator Elements of the Basic Unit	50
5.1.1	The Front	50
5.1.2	The Rear	52
5.2	Switching the Basic Unit ON/OFF	53
5.3	Management Blade Configuration	55
5.4	Updating System Components	60
5.4.1	Updating the Server Blade Firmware (BIOS and BMC)	60
5.4.2	Updating the Management Blade Firmware	62
5.4.3	Updating the Switch Blade Firmware	64
6	Property and Data Protection	69
6.1	BIOS Setup Security Functions	69
7	Server Blades	71
7.1	Installation Sequence	73
7.2	Adding a Server Blade to the Basic Unit	76
8	LAN Switch Blades	81
8.1	Gbit Ethernet LAN switch blade (SB9) 6x1Gbit	82
8.2	Gbit Ethernet LAN switch blade (SB9) 6x1 Gbit + 2x10 Gbit	84
8.3	Cisco Catalyst Blade Switch 3040	86
8.4	10 Gbit Switch Blade 10/2	88
8.5	Port Assignment of the LAN Switch Blades	90
8.6	Installing a LAN Switch Blade	93

9	Ethernet Pass-Thru Blade	99
<hr/>		
9.1	Control and Connection Panel	100
9.2	Port Assignment of the Gigabit Ethernet Pass-Thru Blades	101
9.3	Replacing an Ethernet Pass-Thru Blade	104
10	Fibre Channel Switch Blade	105
<hr/>		
10.1	Control and Connection Panel	106
10.2	Port assignment	108
10.3	FC switch blade installation	111
11	Fibre Channel Pass-Thru Blade	113
<hr/>		
11.1	Control and Connection Panel	114
11.2	Fibre Channel SFP module	115
11.3	Port Assignment of the FC Pass-Thru Blades	117
11.4	Exchanging an FC Pass-Thru Blade	121
12	Management Blade	125
<hr/>		
12.1	Control and Connection Panel	126
12.2	Exchanging the Battery	128
12.3	Exchanging a Management Blade	130
13	KVM Blade	133
<hr/>		
13.1	KVM Blade (Standard Version)	133
13.2	Adv. KVM Blade	135
13.3	Digital KVM Blade	137

Contents

14	Power Supply Concept	139
14.1	Power Supply Units	140
14.1.1	Replacing a Power Supply Unit	142
14.1.2	Adding a Power Supply Unit	145
15	Ventilation Concept	149
15.1	The Fan Unit	150
15.1.1	Replacing the Fan Unit	151
15.1.2	Replacing a Fan in the Unit	153
16	Troubleshooting and Tips	155
16.1	System Power LED Remains Unlit	155
16.2	Front or Rear Identify/Fault LED Blinks Amber	156
16.3	System Switches Itself OFF	157
16.4	Screen Remains Dark	157
16.5	Flickering Stripes on the Monitor Screen	158
16.6	No Screen Display or Display Drifts	158
16.7	No Mouse Pointer Displayed On the Screen	158
16.8	Floppy Disk Cannot Be Read/Written	159
16.9	Time and Date Are Not Correct	159
16.10	Server Blade Does Not Boot	159
16.11	Defective Drive	159
Abbreviations		161
Related Publications		165
Index		169

1 Introduction

The PRIMERGY BX600 S2 Blade Server System represents a highly compact, power-saving and scalable servers for integration in 19-inch rack systems.



Figure 1: PRIMERGY BX600 S2 Basic Unit

The PRIMERGY BX600 S2 basic unit occupies seven height units in the rack and can accommodate up to ten server blades of different models and configurations.

As economical, ultra-compact systems, the server blades with up to eight CPUs are ideal for use by company data centers and Internet service providers. They are perfectly suited for large application servers, terminal servers for CPU-intensive applications, and DBMS servers.

The PRIMERGY BX600 S2 Blade Server System offers a high level of reliability and availability through highly developed hardware and software components. This includes hot-swappable server blades, switch blades, Fibre Channel (FC) and Ethernet pass-thru blades, management blades, hot-swappable power supply units and fan modules, the server management software *ServerView*, and *Remote-Deploy*, Prefailure Detection and Analyzing (PDA), and Automatic Server Reconfiguration and Restart (ASR&R).

Security functions in the *BIOS Setup* protect the data on the server blades against manipulation. Additional security is provided by the lockable rack door.

1.1 Overview of the Documentation



PRIMERGY manuals are available in PDF format on the ServerBooks DVD. The ServerBooks DVD is part of the *PRIMERGY ServerView Suite* delivered with each server system.

The PDF files for the manuals can also be downloaded free of charge from the Internet. The overview page showing the online documentation available in the Internet can be found via the URL:

<http://manuals.fujitsu-siemens.com/primergyservers.html>.

Concept and Target Group of this Manual

This operating manual is intended for those responsible for installing the hardware and operating the system. The manual contains all the information required for mounting and operating your PRIMERGY BX600 S2 basic unit.

For a brief overview of the installation steps please see chapter 2 on page 19ff.

To understand the different expansion options, you need a knowledge of hardware and data transmission, as well as basic knowledge of the operating system used.

Additional server documentation

The PRIMERGY BX600 S2 documentation also includes:

- “Quick Start Hardware - PRIMERGY BX600 S2/S3” (leaflet)
- “Quick Start Software - PRIMERGY ServerView Suite” (leaflet)
- “Warranty” manual (print version supplied with the system, PDF file available on the *ServerBooks* DVD supplied)
- “Safety notes and other important information” manual (print version supplied with the system, PDF file available on the *ServerBooks* DVD supplied)
- “Ergonomics” manual (PDF file available on the *ServerBooks* DVD supplied)
- “Returning used devices” manual (PDF file available on the *ServerBooks* DVD supplied)
- “Helpdesk” (leaflet with worldwide helpdesk telephone numbers)
- Technical Manual for the Dxxxx system board (PDF file available on the *ServerBooks* DVD supplied)

- “BIOS Setup” (PDF file available on the *ServerBooks* DVD supplied)
- “ServerView Suite” includes the *ServerStart* Disc 1, the *ServerStart* Disc 2 and the *ServerBooks* DVD. The PDF version of the “PRIMERGY ServerView Suite - ServerStart” user manual is also available on the *ServerBooks* DVD.



If you need a replacement copy of the *ServerBooks* DVD, send the details of your sever to the following e-mail address:

Reklamat-PC-LOG@fujitsu-siemens.com

- „PRIMERGY BX Blade Server Systems: RemoteView Management Blade - User Interface Description“ (PDF-Version auf *ServerBooks-DVD* enthalten)
- „PRIMERGY BX Blade Server Systems: LAN Switch Blade - User Interface Description“ (PDF-Version auf *ServerBooks-DVD* enthalten)
- „PRIMERGY BX Blade Server Systems: Cisco Catalyst Blade Switch 3040 - Hardware Installation Guide“ (PDF-Version auf *ServerBooks-DVD* enthalten)
- „PRIMERGY BX Blade Server Systems: LAN Router and Switch Blade - User Interface Description“ (PDF-Version auf *ServerBooks-DVD* enthalten)
- „BX600 Digital KVM Switch: User Guide“ (PDF-Version auf *ServerBooks-DVD* enthalten)

Further Sources of Information

Further information is provided in:

- the RemoteDeploy manual (only relevant for cloning server blades)
- the technical manual for the rack
- the manual for the monitor
- the ServerView Server Management manual
- the manual for the Remote Test and Diagnostic System *RemoteView*
- your operating system documentation
- the information files of your operating system

(see also “[Related Publications](#)” on page 165).

1.2 Features

The PRIMERGY BX600 S2 basic unit provides a high-level infrastructure for the installed server blades.

Server capacity

The PRIMERGY BX600 S2 basic unit provides slots for up to ten hot-pluggable server blades. For details of the performance features of the different server blade models, see the relevant operating manuals listed under [“Related Publications” on page 165](#).

Communication interfaces

The PRIMERGY BX600 S2 basic unit has four slots on the back for installing different types of communication blades which allow the installed server blades to be connected to the Ethernet LAN or to SAN environments. The connections can be implemented via switch blades and/or pass-thru blades.

- Ethernet LAN switch blade

To connect the server blades to the LAN the following switch blade models are available:

Gbit Ethernet LAN switch blade (SB9) 6x1Gbit

- 10 internal 1Gbit downlink ports to the server blades
- 6 external 1Gbit uplink ports (RJ45)

Gbit Ethernet LAN switch blade (SB9) 10Gbit multi-mode

- 10 internal 1Gbit downlink ports to the server blades
- 6 external 1Gbit uplink ports (RJ45)
- 2 external 10Gbit uplink ports (1xSFP, 1xCX4)

Cisco Catalyst Blade Switch 3040

- 10 internal 10 1Gbit downlink ports to the server blades
- 2 external 10/100/1000BASE-T copper Gigabit Ethernet uplink ports
- 4 external uplink ports via Cisco SFP modules for 1000BASE-SX Fibre Optic and 10/100/1000BASE-T copper)

10 Gbit switch blade 10/2

- 10 internal 10 Gbit/s ports to the server blades
- 2 external 10 Gbit/s ports with optional X2 transceiver modules for Fiber optical or CX4 copper cable



The 10 Gbit switch blade 10/2 only supports server blades, each equipped with a 10 GbE daughter card.

All switch blades are hot-swappable. By installing two switch blades, redundant LAN connections can be provided for the server blades.

- Ethernet LAN Pass-Thru-Blade

The Ethernet LAN Pass-Thru-Blade is an alternative to the switch blade. It provides direct (“pass-thru”) connections to the LAN for the onboard LAN controllers and the optional Gigabit Ethernet I/O modules of the server blades. The Ethernet LAN Pass-Thru-Blade has ten RJ45 connectors.

- Fibre Channel pass-thru blade

The PRIMERGY BX600 S2 basic unit can have one or two Fibre Channel pass-thru blades to provide Fibre Channel functionality for the installed server blades. A Fibre Channel (FC) pass-thru blade offers 10 ports for bypass connections between FC daughter cards installed in the server blades and the optical transceivers for serial FC I/O and general I/O signals.

- Fibre Channel switch blade

The FC switch blade is an alternative to the FC pass-thru blade. An FC switch blade provides the FC daughter cards of the server blades with up to ten internal fabric ports and up to four external fabric ports. The complete *Brocade Fabric OS 5.0.4* scope of supply and services is available as an operating system for the FC switch blade.

Management blade

The PRIMERGY BX600 S2 basic unit accommodates two hot-swappable, redundant management blades with an integrated management solution for complete remote administration of the system.

KVM-Blade

For administering the server blades, the PRIMERGY BX600 S2 basic unit offers a KVM blade, which allows the individual server blades to be connected to a console.

- The **standard KVM blade** allows a monitor, PS2 keyboard and PS2 mouse to be connected for local administration of the server blades.
- The **adv. KVM blade** offers the same functionality as the standard version of the KVM blade plus a LAN port for connecting a Web-based console.
- The **digital KVM blade** offers the same functionality as the standard version of the KVM blade plus a LAN port for connecting a Web-based console.

Power Supply

Up to four hot-swappable power supply units which adjust automatically to any power voltage in the range 200 - 240 V in a 2+2 redundant power supply configuration ensure enough power for the system. If one of these units fails, the others ensure that operation continues unimpaired. The defective power supply unit can be replaced during operation (hot-swap).

Ventilation

The system is kept cool by three fans in each power supply unit and four single fans, with two of them mounted one after the other in a housing in the rear chassis. This configuration is redundant and hot-swappable.

High Level of Availability and Failure Protection

When memory data is accessed, 1-bit errors in the main memory are recognized and automatically corrected with the ECC (Error Correcting Code) method.

ASR&R (Automatic Server Reconfiguration and Restart) restarts the system in the case of an error and automatically “hides” the defective system components.

The PDA (Prefailure Detection and Analyzing) technology from Fujitsu Siemens Computers analyzes and monitors all components relevant for system reliability.

The hot-swappable components provide additional failure protection. Failure protection on a complete blade system is ensured by up to four redundant, hot-swap power supply units (PSU), as well as hot-swap, redundant fans.

Server Management

Server management is implemented via the supplied *ServerView* software and PDA (Prefailure Detection and Analyzing) technology from Fujitsu Siemens Computers. PDA warns of system errors or overloading before they occur so that preventive measures can be taken.

ServerView allows the management of all PRIMERGY servers in the network via a central console. Here *ServerView* supports the following functions:

- Remote startup (Wake On LAN)
- Temperature monitoring of the CPU and the surrounding area
- Watchdog timer for Automatic Server Reconfiguration and Restart (ASR&R) in the event of memory modules or processors failing
- Power monitoring
- End-of-life monitoring of the fans with timely notification before a failure
- Watchdog timer for operating system monitoring and application monitoring with ASR&R

Deployment software makes installing multiple servers fast and easy. For further information, see the corresponding documentation (see [“Related Publications” on page 165](#)).

Information on server management with *ServerView* is provided in the associated documentation (see also [“Related Publications” on page 165](#)).

ServerStart

You can configure the server quickly and precisely with the *ServerStart* software provided. User-guided menus are available for installing the server operating systems.

Service and Support

PRIMERGY servers are service-friendly and modular, thus allowing quick and easy maintenance.



For easy and immediate recognition, the levers or handles and locking buttons (touch points) of the locking mechanisms for the different components have the color green.

The flash EPROM program supplied with the Fujitsu Siemens utilities supports fast BIOS update. The two redundant and hot-swappable management blades with independent management LAN and COM ports ensure complete remote control. Together they facilitate remote diagnosis for system analysis, remote configuration and remote restart, should the operating system or hardware fail.

1.3 Notational Conventions

The following notational conventions are used in this manual:



<i>Italics</i>	indicate commands, menu items or software programs.
“Quotation marks”	indicate names of chapters and terms that should be emphasized.
▶	Text which follows this symbol describes activities that must be performed in the order given.
 CAUTION!	Pay particular attention to text marked with this symbol. Failure to observe this warning may endanger your life, damage the server, or lead to loss of data.
	This symbol introduces supplementary information, remarks and tips.

Table 1: Notational conventions

1.4 Technical Data

Electrical Data (single power supply unit)

Rated voltage range	200 - 240 V
Rated frequency	50 Hz - 60 Hz
Max. rated current	230V / 11,6 A
Max. active power	230 V / 2650 W
Max. apparent power	2680 VA (230V)
Thermal dissipation	2050 kJ/h
Protection class	I

Electrical Data (basic unit without server blades)

Power consumption	360 W
Thermal dissipation	1300 kJ/h

Compliance Standards

Product safety and ergonomics	IEC 60950 / EN 60950 UL 1950 3rd Edition, CSA 22.2 No. 950
Electromagnetic compatibility	FCC class A
Emitted interference	EN 55022 class A
Harmonic current	EN 61000-3-2
Noise immunity	EN 55024
CE label according to EU directives	Low-Voltage Directive 73/23/EEC Electromagnetic Compatibility 89/336/EEC

Certification

Product safety	
Global	CB

Europe	ENEC
Germany	GS
USA/Canada	CSA _{US} / CSA _C
Japan	VCCI

Mechanical Values

Width	446 mm
Installation depth	740 mm
Height	307 mm oder 7 HE

Weight

max. 131.5 kg (depending on the configuration)

Environmental Conditions

Environment class 3K2	DIN IEC 721 section 3-3
Environment class 2K2	DIN IEC 721 section 3-2
Temperature:	
Operation (3K2)	5 °C 35 °C
Transport (2K2)	-20 °C 60 °C
Relative humidity	10%...85%

Condensation during operation must be avoided.

Noise Level

Sound power level L_{WA_d} (ISO 7779)	7.8 BA
Sound pressure level at bystander position L_{pAm} (ISO 9296)	≤ 59 dB(A) (in the standard configuration)

2 Overview: Basic Unit Installation Steps

In this chapter you will find an overview of the steps necessary to install your BX600 S2 basic unit. Links guide you to sections where you can find more detailed information on the individual steps.

- ▶ Before you begin, please read the [chapter “Important Notes”](#) beginning on [page 21](#), especially the [section “Notes on Safety”](#).
- ▶ Unpack the system, check the contents of the package for visible transport damage, and check whether the delivery matches the details in the delivery note (see [section 4.2 on page 34](#)).
- ▶ Mount the system in the rack (see [section 4.3 on page 35](#) and also the layout arrangement on the order lists).
- ▶ Cable the system (see [section 4.4 on page 41](#)). Please also see the [section “Cable Routing” on page 43](#) and the [section “Instructions on Connecting and Disconnecting Cables” on page 45](#).
- ▶ Connect the system to the mains voltage (see [section 4.5 on page 46](#)).
- ▶ Familiarize yourself with the operating and indicator elements on the front and rear sides of the BX600 S2 basic unit (see [chapter 5 beginning on page 49](#)).
- ▶ Insert the server blades into the slots in the front of the BX600 S2 basic unit (see [chapter 7 on page 71](#)).
- ▶ Configure the management blades (see [section 5.3 on page 55](#)) so that you can perform further administration of the blade server system via LAN.
- ▶ Install the desired operating systems and applications on the server blades.

To do so, you have the following options:

- *Cloning a server blade from a remote image server with RemoteDeploy*

Recommended if the following requirements are satisfied:

- the RemoteDeploy software is available
- an appropriate cloning image is available
- deployment server and LAN connection are available

– *Remote installation with ServerStart*

This installation method is recommended if a LAN connection and a DHCP server are available but the requirements for cloning are not satisfied.

– *Local installation with or without ServerStart*

Since the local installation is the least convenient installation method, it is only recommended if the requirements for remote installation or cloning are not satisfied.

If you wish to install an operating system that is not supported by ServerStart, you can perform the installation directly without using ServerStart.



For further information on remote or local installation of server blades, please see the ServerStart manual, which contains a “Quick Step Guide” as well as a detailed description of the different installation options and installation wizards. A print version of the ServerStart manual is included in the *PRIMERGY ServerView Suite*, which comes with the BX600 S2 basic unit. A PDF version of the manual is contained on the PRIMERGY ServerBooks DVD.

Cloning of server blades is described in the RemoteDeploy manual (print version delivered with RemoteDeploy, PDF version contained on the PRIMERGY ServerBooks DVD).

3 Important Notes

In this chapter you will find essential information on safety when working with your system.

3.1 Notes on Safety



You will also find the following safety instructions in the manual entitled “Safety“, which also includes additional notes on the guarantee and ergonomics.

This device complies with the relevant safety regulations for data processing equipment, including electronic office machines for use in an office environment.

If you have any questions, please contact your sales outlet or the customer service center of Fujitsu Siemens Computers.



CAUTION!

The actions described in these instructions should only be performed by technicians, service personnel or technical specialists. Equipment repairs should only be performed by qualified staff. Any failure to observe the guidelines in this manual could expose the user to risks (electric shock, fire hazards) and could also damage the equipment. Note that any unauthorized opening of the device will result in the invalidation of the warranty and exclusion from all liability.

Before Setting Up



CAUTION!

- During installation and before operating the device, observe the instructions on environmental conditions for your device in the [section “Technical Data” on page 15](#).

- If the device is brought in from a cold environment, condensation may form on both the inside and outside of the machine.

Before operating the device, wait until it is absolutely dry and has reached approximately the same temperature as the installation site. Failure to observe these guidelines can lead to physical damage of the device.

- Transport the device only in the original packaging or in packaging which protects it from knocks and jolts.

Installation and Operation



CAUTION!

- **For safety reasons, make sure you read any warning labels when removing modules from the server.**
- Beware of energy hazards on the plug-in contacts of the midplane. A short circuit on these connections can lead to damage to the system.
- PRIMERGY BX620 S4 server blades are not for use in slots 4 and 10 of the PRIMERGY BX600 S2 basic unit.
- If the server is integrated in a (rack) installation that receives power from an industrial (public) power supply network with the IEC309 connector, the (public) power supply protection must comply with the requirements for the non-industrial (public) power supply networks for the type-A connector.
- For the PRIMERGY BX600 S2 basic unit only 2100W PSUs are allowed (Product no. A3C40073262)! The 1200W PSUs of the PRIMERGY BX600 S1 basic unit is not allowed for the PRIMERGY BX600 S2 basic unit.

The 2100W PSU is not allowed for the PRIMERGY BX600 S1 basic unit.

- Make sure that the PRIMERGY BX600 S2 basic unit is connected to the mains for at least one minute before pressing the power ON/OFF button to switch the system ON.

**CAUTION!**

- The server automatically adjusts to a mains voltage of 200 - 240 V. The server may only be put into operation if the mains voltage range set on the server corresponds to the local mains voltage.
- This device has safety-tested power cables and must only be connected to properly grounded power sockets or CEE sockets.
- The power button does not disconnect the device from the mains voltage. To completely disconnect it from the mains voltage, the power plugs must be removed from the power socket.
- Data transmission cables must not be connected or disconnected during a thunderstorm (lightning hazard).
- Make sure that no objects (such as bracelets or paper clips) or liquids fall/spill into the device (risk of electric shock or short circuit).
- Data cables must be adequately shielded to avoid interference.
- The LAN wiring must comply with the standards EN 50173 and EN 50174-1/2. The minimum requirement is a protected LAN line of category 5 for 10/100 MBps Ethernet, and/or of category 5e for Gigabit Ethernet. The requirements of the specification ISO/IEC 11801 must be observed.
- In an emergency (e.g. damage to housing, control elements or cables, the ingress of liquids or foreign bodies), switch the unit off immediately, pull the power plug out of the grounding outlet or the CEE outlet, and contact Service.
- Proper operation of the device (in accordance with IEC 60950/DIN EN 60950) is only ensured if the casing is completely assembled and the dummy units for the installation openings have been put in place (electric shock, cooling, fire protection, interference suppression).
- Install only system extensions that satisfy the requirements and rules governing safety and electromagnetic compatibility and relating to telecommunications terminal equipment. If you install other extensions, you may damage the system or violate the safety regulations

and regulations on RFI suppression. Information on which system extensions are suitable can be obtained from the customer service center or your sales outlet.

**CAUTION!**

- The components (e.g. power supply) marked with a warning label (e.g. lightning symbol) may only be opened, removed or exchanged by authorized, qualified personnel. The hot-swap or hot-plug components are exceptions to this rule.
- The warranty is invalidated if the device is damaged during the installation or replacement of system extensions.
- You may set only those resolutions and refresh rates specified in the “Technical data” section of the monitor description. Otherwise, you may damage your monitor. If you are in any doubt, contact your sales outlet or customer service center.

Batteries**CAUTION!**

- Incorrect replacement of batteries may lead to a risk of explosion. The battery may only be replaced with an identical battery or with a type recommended by the manufacturer.
- Do not throw batteries into the trash can. They must be disposed of in accordance with local regulations concerning special waste.
- Replace the lithium battery on the relevant components according to the instructions in this manual.
- All batteries containing pollutants are marked with a symbol (a crossed-out garbage can) as well as the chemical symbol for the heavy metal which classifies it as a pollutant:

Cd Cadmium

Hg Mercury

Pb Lead

Other Important Notes:

- Keep this operating manual and all additional documentation together with the device.
If you pass on the device to third parties, you should also pass on the complete documentation.

3.2 Components With Electrostatic-Sensitive Devices

Electrostatic-sensitive components are identified by the following sticker:



Figure 2: ESD label

When you handle components fitted with ESDs, you must observe the following points under all circumstances:

- Always discharge static build-up (e.g. by touching a grounded object) before working.
- The equipment and tools you use must be free of static charge.
- Always hold components with ESDs by their edges.
- Do not touch any exposed pins or conductors on a component.
- Use a grounding cable designed for this purpose to connect yourself to the system unit as you install components.
- Place all components on a static-proof base.



You will find a detailed description of how to handle ESD components in the relevant European or international standards (EN 61340-5-1, ANSI/ESD S20.20).

3.3 CE Certificate



The shipped version of this device complies with the requirements of the EEC directives 89/336/EEC “Electromagnetic compatibility” and 73/23/EEC “Low voltage directive”. The device therefore qualifies for the CE certificate (CE=Communauté Européenne).

3.4 FCC Class A Compliance Statement

If there is an FCC statement on the device, then:

The following statement applies to the products covered in this manual, unless otherwise specified herein. The statement for other products will appear in the accompanying documentation.

NOTE:

This equipment has been tested and found to comply with the limits for a "Class A" digital device, pursuant to Part 15 of the FCC rules, and meets all requirements of the Canadian Interference-Causing Equipment Standard ICES-003 for digital apparatus. These limits are designed to provide reasonable protection against harmful interference in a residential installation. This equipment generates, uses and can radiate radio frequency energy and, if not installed and used in strict accordance with the instructions, may cause harmful interference to radio communications. However, there is no guarantee that interference will not occur in a particular installation. If this equipment does cause harmful interference to radio or television reception, which can be determined by turning the equipment off and on, the user is encouraged to try to correct the interference by one or more of the following measures:

- Reorient or relocate the receiving antenna.
- Increase the separation between equipment and the receiver.
- Connect the equipment to an outlet on a circuit different from that to which the receiver is connected.
- Consult the dealer or an experienced radio/TV technician for help.

Fujitsu Siemens Computers is not responsible for any radio or television interference caused by unauthorized modifications of this equipment or the substitution or attachment of connecting cables and equipment other than those specified by Fujitsu Siemens Computers. The correction of interferences caused by such unauthorized modification, substitution or attachment will be the responsibility of the user.

The use of shielded I/O cables is required when connecting this equipment to any and all optional peripheral or host devices. Failure to do so may violate FCC and ICES rules.

3.5 Transporting the Basic Unit



CAUTION!

Transport the PRIMERGY BX600 S2 basic unit only in its original packaging or in a packaging which protects it from knocks and jolts. Do not unpack the basic unit until you have finished transporting it.

For safety reasons, at least two people are needed to install the basic unit because of its weight and size.

Before lifting the basic unit into the rack, remove server blades, fan units and power supplies from the system unit to reduce weight.

Use the handles on the front and the fold-away handles on the long sides to lift or carry the base unit.

Never lift or transport the basic unit using the handles on the rear.

3.6 Notes on Installing in the Rack



CAUTION!

- **For safety reasons, at least two people are needed to install the basic unit because of its weight and size.**
- For lifting the basic unit, use the handles on the front and the fold-out handles on the long sides of the chassis.
- Before lifting the basic unit into the rack, remove server blades, fan units and power supplies from the system unit to reduce weight.
- For lifting the basic unit, use the handles on the front and the fold-out handles on the long sides of the chassis.
- Never lift or transport the server using the handles on the rear.
- For safety reasons only one unit may be withdrawn from the rack at a time when performing assembly or service work.
- Ensure that the anti-tilt bracket is correctly mounted when you set up the rack.
- If more than one unit is withdrawn from the rack at any one time, the rack is in danger of tilting forward.
- When connecting and disconnecting cables, read the relevant notes in the “Important notes” chapter in the technical manual for the relevant rack. The technical manual is supplied with the corresponding rack.
- The power connection for the rack must be installed by an authorized technician (electrician).
- If the server is integrated in a (rack) installation that receives power from an industrial (public) power supply network with the IEC309 connector, the (public) power supply protection must comply with the requirements for the non-industrial (public) power supply networks for the type-A connector.
- The power supply for the rack should be divided amongst the three phases of a three-phase power connection.

3.7 Environmental Protection

Environmentally Friendly Product Design and Development

This product has been designed in accordance with the Fujitsu Siemens Computers standards for "environmentally friendly product design and development". This means that the designers have taken into account important criteria such as durability, selection of materials and coding, emissions, packaging, the ease with which the product can be dismantled and the extent to which it can be recycled.

This saves resources and thus reduces the harm done to the environment.

Notes on Saving Energy

Devices that do not have to be on permanently should not be switched on until they need to be used and should be switched off during long breaks and on completion of work

Notes on Packaging

Please do not throw away the packaging. It may be needed later for transporting your system unit. If possible, devices should be transported in their original packaging.

Notes on Dealing with Consumables

Please dispose of printer consumables and batteries in accordance with local government regulations.

Do not throw batteries and accumulators into the household waste. They must be disposed of in accordance with local regulations concerning special waste (see also "[Returning Batteries](#)" on page 31).

Notes on Labeling Plastic Housing Parts

Please avoid attaching your own labels to plastic housing parts wherever possible, since this makes it difficult to recycle them.

Returning Used Electrical and Electronic Devices in EU Countries

– Separate collection

Users of electrical and electronic devices are obligated to collect used devices separately. Electrical (electronic) used devices may not be disposed of together with unsorted household refuse. The separate collection is a condition for reuse, recycling and utilisation of used electrical (electronic) devices, which ensures the protection of resources.

– Return and collection systems

Electrical (electronic) used devices from private households can be returned free of charge. To return your used device, please use the country-specific return and collection systems available to you (see [“Local Contacts”](#) on page 31).

The return of used devices which pose a health or safety risk for human beings due to soiling during use may be refused.

– Reuse, recycling and utilisation

By actively using the offered return and collection systems, you make your contribution to the reuse, recycling and utilisation of electrical (electronic) devices.

– Effects on the environment and human health

Electrical (electronic) used devices contain parts which must be handled selectively according to the EU directive. Separate collection and selective treatment are the basis for environment-friendly disposal and the protection of human health.

– Meaning of the symbol "Crossed out rubbish bin on wheels"

Electrical (electronic) devices which are marked with one of the following symbols may not be disposed of with household refuse in accordance with the EU directive.

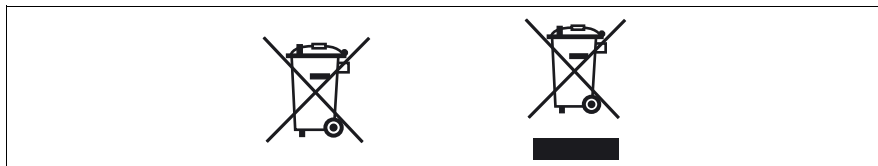

Figure 3: Symbols for electrical (electronic) devices

Returning Batteries

Batteries which are marked with one of the following symbols may not be disposed of together with household refuse according to the applicable EU directive.

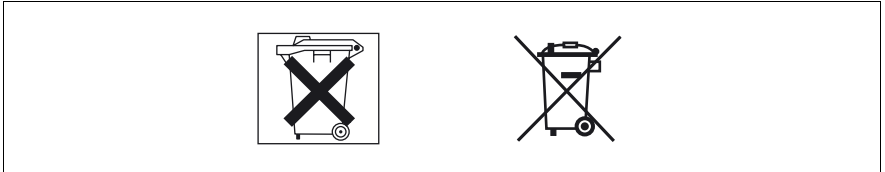

Figure 4: Symbols for batteries

With batteries containing harmful substances, the chemical symbol for the heavy metal contained is indicated below the waste bin.

Cd Cadmium

Hg Mercury

Pb Lead

The following applies to Germany:

- Private consumers can return batteries at the point of sale or the immediate vicinity thereof free of charge (exception: starter batteries).
- The final consumer is obligated to return defective or used batteries to the seller or to the return points established for this purpose.

Local Contacts

For details on take-back and reuse of devices and consumables within Europe, contact your Fujitsu Siemens Computers branch office/subsidiary or our recycling centre in Paderborn:

Fujitsu Siemens Computers

Recycling Center

D-33106 Paderborn

Tel.: +49 5251 8 18010

Fax +49 5251 8 18015

Internet: www.fujitsu-siemens.com/recycling

4 Installing the Hardware



CAUTION!

Please note the safety instructions in the [chapter “Important Notes” on page 21](#).

Do not expose the PRIMERGY BX600 S2 basic unit to extreme environmental conditions (see [section “Technical Data” on page 15](#)). Protect it from dust, moisture, and heat.

4.1 Installation Steps

The installation steps are described in detail in the following sections of this chapter:

- [Unpacking the basic unit \(see section “Unpacking the Basic Unit” on page 34\)](#).
- [Mounting the basic unit in the rack \(see section “Installing the System in the Rack” on page 35 and also the layout arrangement on the order lists\)](#).
- [Cabling the basic unit \(see section “Connecting External Devices” on page 41\)](#). See also the [section “Cable Routing” on page 43](#) and the [section “Instructions on Connecting and Disconnecting Cables” on page 45](#).
- [Connecting the basic unit to the mains voltage \(see section “Connecting the System to the Mains” on page 46\)](#).

4.2 Unpacking the Basic Unit



CAUTION!

Please note the safety instructions in the [chapter “Important Notes” on page 21](#).

Do not unpack the PRIMERGY BX600 S2 basic unit until you have finished transporting it.

We recommend that you do not throw away the original packaging material! It may be required for future transportation.

- ▶ Unpack all the individual parts.
- ▶ Check the contents of the package for visible transport damage.
- ▶ Check whether the delivery matches the details in the delivery note.

The identification rating plate is located on the front edge of the left side of the basic unit.

If you find transport damage or inconsistencies between the contents of the package and the delivery note, inform your supplier immediately!

4.3 Installing the System in the Rack



CAUTION!

- **For safety reasons, at least two people are required to install the PRIMERGY BX600 S2 basic unit because of its weight and size.**
- Please observe the safety precautions and references to rack installation in the [chapter “Important Notes” on page 21](#).
- The rack may tip over if more than one unit is removed at the same time.

Requirements of the Rack

The rack systems from Fujitsu Siemens Computers GmbH (PRIMECENTER rack; DataCenter rack) fully support the installation of the PRIMERGY server systems. Installation in the common rack systems of other manufacturers (**3rd-party rack**) is supported to a large degree.

To accommodate the ventilation concept and ensure proper ventilation of the components in the rack, any unused areas must be closed using dummy covers.

The unit is connected to the power supply via an external distribution board or a UPS device.

The main features of the rack systems from Fujitsu Siemens Computers GmbH are:

PRIMECENTER/DataCenter Rack

- Frontally bolted rails.
The rails have a linear alignment option to also allow adjustment to different rack depths.
- Extended cable management within the lateral rack area.

The following applies to rack systems from third-party manufacturers:

3rd-Party Rack

Certain framework conditions must be fulfilled:

- Installation dimensions (see the dimensions shown in [figure 5 on page 37](#)).
 - 1 rack front
 - 2 rack rear
 - A rack depth (comparison PRIMECENTER rack 940/1000 mm)
 - B rack width (comparison PRIMECENTER rack 700 mm)
 - C clearance of the 19-inch installation level
 - C1 front 19-inch installation level
 - C2 rear 19-inch installation level
 - D area for cable routing (cable area depth) and ventilation
 - E area for front panel and ventilation
 - F right and left area for support systems
 - P PRIMERGY installation depth
 - a1 front left support upright
 - a2 front right support upright
 - b1 rear left support upright
 - b2 rear right support upright
- Please ensure that the security mechanism (e.g. stopper or retention system) on the server is working.
- The rack support uprights must allow the rails to be screwed on at the front.
- Frontally bolted rails.
The rails have with a linear alignment option to also allow adjustment to different rack depths.
- No support for the cable management delivered with the mounting kit. This cable management is customized for the Fujitsu Siemens Computers PRIMECENTER rack.
- Climatic conditions.
For the ventilation of the installed server, there must be sufficiently large gaps for air intake at the front of the rack and air discharge at the back of the rack.

In principle the ventilation concept allows for the necessary cooling through horizontal self-ventilation of the installed devices (air flow from the front to the rear).

- Power supply.
For installation in 3rd-party racks, you must ensure that appropriate socket strips are present.

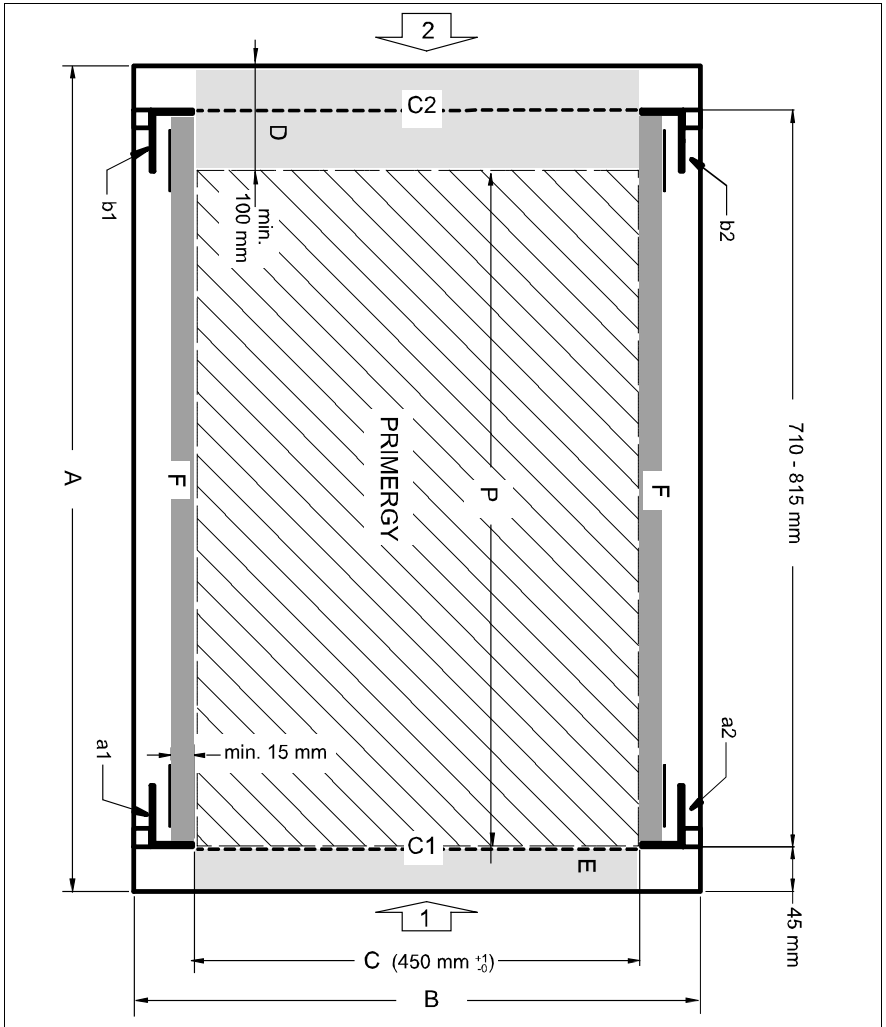

Figure 5: Mechanical conditions

4.3.1 Mounting the Assembly Kit

Mounting the server in the PRIMECENTER/DataCenter Rack requires the following parts:

- two support brackets
- two carrier rails (assembled)
- 12 plug washers ([figure 7 on page 39](#)) and screws



For general information see the technical manual for the relevant rack (see also [“Related Publications” on page 165](#)).

To mount the PRIMERGY BX600 S2 basic unit in the rack, you must first mount two support brackets on the rear left support upright of the rack. The first one must be mounted level with the lower edge of the device, while the second must be mounted level with the upper edge of the first. The brackets are used for the rear fixing of the left carrier rail.

- ▶ See the installation instructions in the technical manual for the relevant rack model.
- ▶ Mark the position of the lower edge of the basic unit on the support uprights.

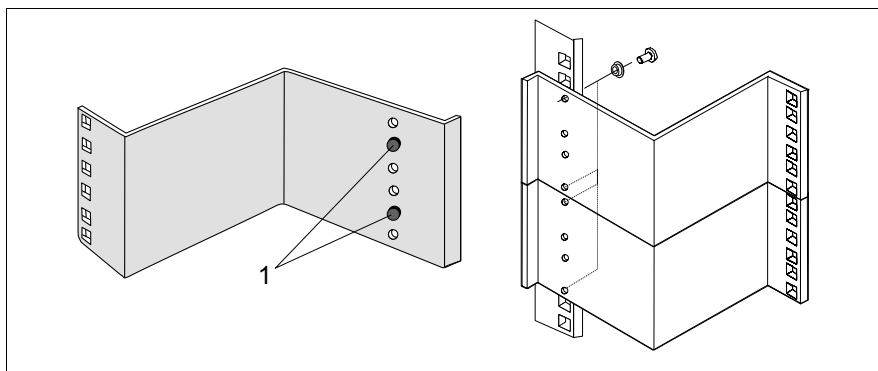

Figure 6: Mounting the support brackets

- ▶ Place the first support bracket at the appropriate height (level with the lower edge of the device) on the left rear support upright by inserting the positioning nubs (1 in [figure 6](#)) in the corresponding holes of the support upright.
- ▶ Place the plug washers in the holes of the support uprights and secure the bracket with two screws.

- ▶ Repeat the procedure with the second support bracket.

Note that the second bracket will be mounted level with the upper edge of the first support bracket mounted (see [figure 6 on page 38](#)).

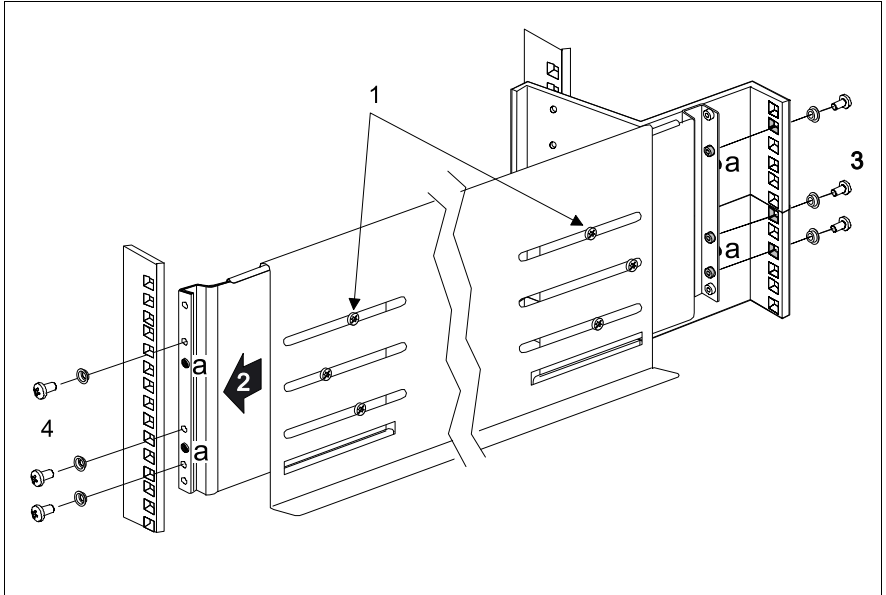

Figure 7: Mounting the left carrier rail

- ▶ Undo the six screws (1) for adjusting the rail length and place the guide lugs (a) in the corresponding holes of the support brackets.
- ▶ Place three plug washers (3) in the appropriate holes of the support brackets and, while holding the rail in place, fasten it with three screws.
- ▶ Place two plug washers in the holes of the front left support upright at the marked attachment points, adjust the rail length (2) and, while holding the rail in place, fasten it with three screws (4).
- ▶ Pull the carrier rail of the rack-mounting kit forward as far as possible in the direction of the arrow (2).
- ▶ Fasten the six screws for adjusting the rail length (1).
- ▶ Repeat the procedure for the second rail. Note that for this rail no support bracket is necessary.

4.3.2 Mounting/Removing the Basic Unit



CAUTION!

For safety reasons, at least two people are required to mount or remove the **PRIMERGY BX600 S2** basic unit because of its weight and size.

Please note the relevant safety instructions in [section “Notes on Installing in the Rack” on page 28](#).

Before lifting the basic unit into the rack, remove server blades, fan units and power supplies from the basic unit to reduce weight.

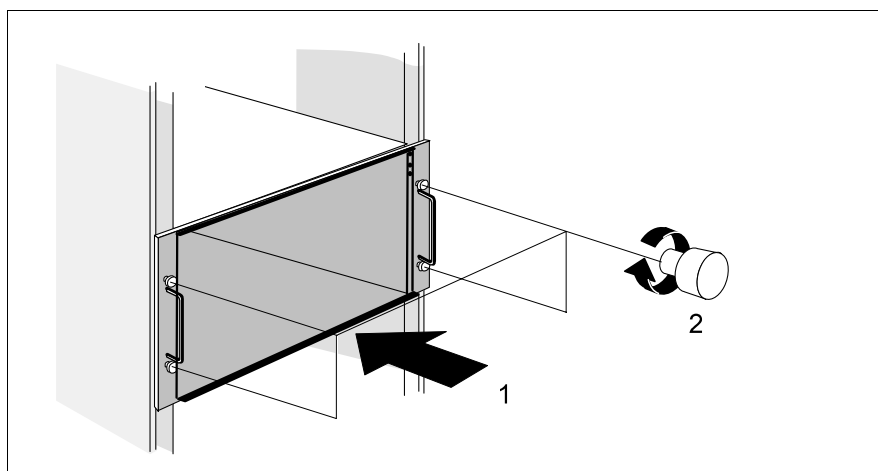

Figure 8: Mounting the basic unit

- ▶ Note the slot assignment of the server blades so that you can insert them correctly again once you have lifted the basic unit into the rack.
- ▶ Remove server blades, fan units and power supplies from the system unit to reduce weight (for assembly instructions see [section “Adding a Server Blade to the Basic Unit” on page 76](#), [section “Replacing a Power Supply Unit” on page 142](#) and [section “Replacing the Fan Unit” on page 151](#)).
- ▶ Lift the basic unit onto the two carrier rails.
- ▶ Slide the basic unit into the rack (1).
- ▶ Secure the basic unit in the rack using the four knurled screws (2).

- ▶ Insert the server blades into their slots (see [section “Adding a Server Blade to the Basic Unit” on page 76](#)). Return the power supply units and fan units to the basic unit (see [section “Replacing a Power Supply Unit” on page 142](#) and [section “Replacing the Fan Unit” on page 151](#)).

You remove the basic unit by following the above steps in reverse order:



CAUTION!

Please note the relevant safety instructions in [section “Notes on Installing in the Rack” on page 28](#).

- ▶ Note the slot assignment of the server blades so that you can insert them correctly again after you have removed the basic unit from the rack.
- ▶ Remove server blades, fan units and power supplies from the basic unit to reduce weight.
- ▶ Remove the four knurled screws.
- ▶ Pull out the basic unit and **carefully** remove it from the rack.

4.4 Connecting External Devices

The external connectors of the PRIMERGY BX600 S2 basic unit are located on the rear of the basic unit. The external connectors of the server blades are located on the front of the basic unit. For information on these connectors see the operating manuals of the different server blade types (see [“Related Publications” on page 165](#)).

Connectors on the back of the basic unit

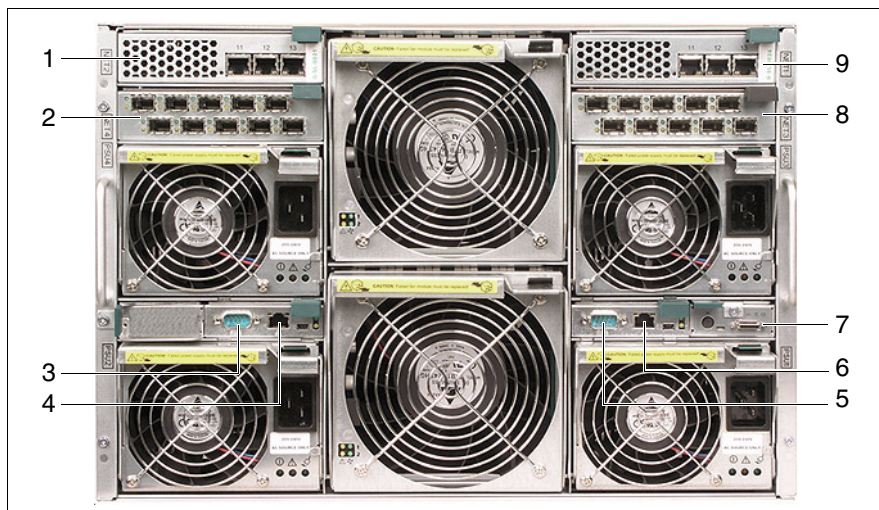

Figure 9: Connectors for external devices

1, 9	Slots for various types I/O blades, connected to the server blades on-board NICs. These I/O blades can be Ethernet switch blades or Ethernet pass-thru blades, see “Ethernet LAN Switch Blades” on page 81 and “Ethernet Pass-Thru Blade” on page 99 .
2, 8	Slots for various types I/O blades, connected to the optional I/O modules of the server blades. These I/O blades can be Ethernet or Fibre Channel switch blades or pass-thru blades, see “Ethernet LAN Switch Blades” on page 81 , “Ethernet Pass-Thru Blade” on page 99 , “Fibre Channel Switch Blade” on page 105 and “Fibre Channel Pass-Thru Blade” on page 113 .
3	Serial port connector on management blade 2 (see also figure 53 on page 100). Standard serial port, management communication port.
4	LAN connector on management blade 2 (see also figure 53 on page 100). LAN port, RJ45, 10Mb management LAN.
5	Serial port connector on management blade 1 (see also figure 53 on page 100). Standard serial port, management communication port.
6	LAN connector on management blade 1 (see also figure 53 on page 100). LAN port, RJ45, 10Mb management LAN.
7	KVM connector on rear KVM blade, which offers VGA, PS2 keyboard and mouse support via a special cable (see figure 10 below). The Adv. KVM blade and the digital KVM blade also offers a LAN connectors (RJ45, 10 Mb) (see also figure 85 on page 134).

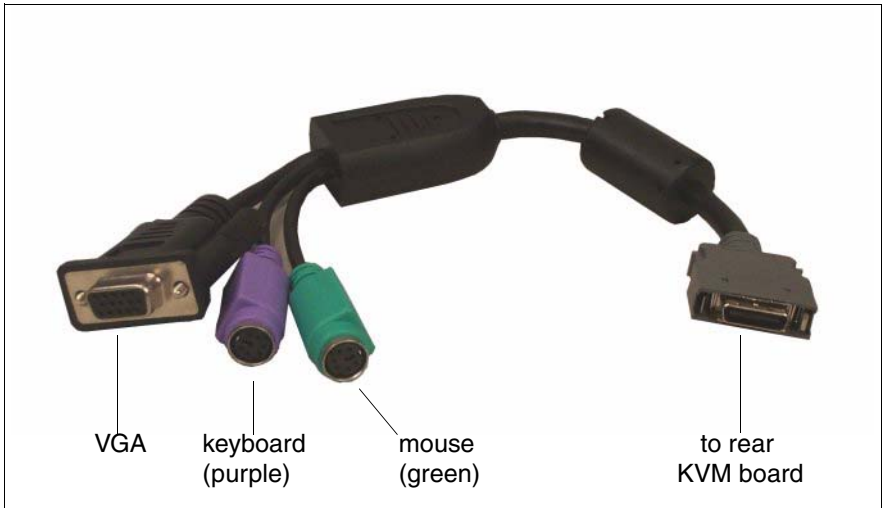

Figure 10: Special cable

4.4.1 Cable Routing

The cables are routed directly on the rack support uprights.

PCI Cards with Cable at the Front

If a PCI expansion module is installed in a server blade, you will have to connect the PCI port with an external device on the back of the rack. To route the cable from the front to the back of the rack, use the side slots of the rack with a cable bezel as shown in [figure 11](#) below. You may also route the cable to the back of the rack, using the space below the basic unit.

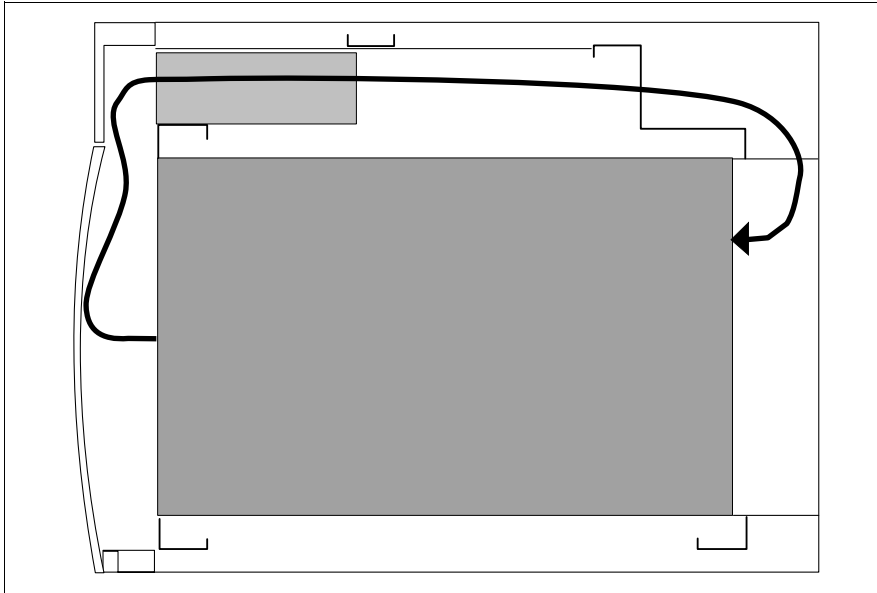

Figure 11: Cable routing from the front to the back of the server (top view)

Server blades with SCSI boards installed via PCI expansion modules can only be installed in slots 5 and 6 of the basic unit. This is why about 100 mm of space is required in front of the server due to the bend radius of the SCSI cable. The curved design of the PRIMECENTER rack door ensures that there is sufficient room for slots 5 and 6.

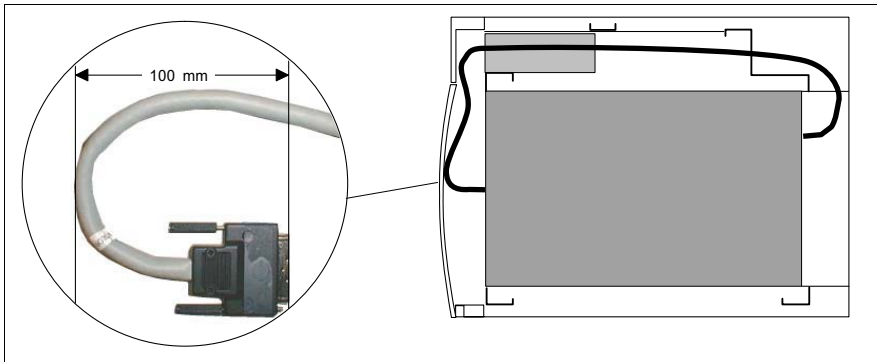

Figure 12: Routing a SCSI cable

4.4.2 Instructions on Connecting and Disconnecting Cables



CAUTION!

Make sure you read the documentation on the devices before connecting them.

Do not connect or disconnect data cables during a thunderstorm.

When removing a cable, always hold it by the plug.

Connect and disconnect the cables in the order described below.

Connecting Cables

- ▶ Turn off all power and equipment switches.
- ▶ Pull all power plugs out of grounded power sockets or CEE sockets.
- ▶ Plug all cables into the system and peripherals. Secure the data transmission cable connections (e.g. nut retention).
- ▶ Plug all data communication cables into the utility sockets.
- ▶ Plug all power cables into the grounded power sockets or CEE sockets.

Disconnecting Cables

- ▶ Turn off all power and equipment switches.
- ▶ Pull all power plugs out of grounded power sockets or CEE sockets.
- ▶ Unplug all data communication cables from the utility sockets.
- ▶ Undo the nut retention on the connector housings and pull the corresponding cables out of the basic unit and the peripherals.

4.5 Connecting the System to the Mains

There are slots for four hot-swappable 2100 W power supply units on the rear of the basic unit. The base system is equipped with two power supply units.



CAUTION!

- Make sure you observe the information on determining how many power supply units are required (see [chapter “Power Supply Concept” on page 139](#)).
- The power supply units switch on automatically at a mains voltage between 200 - 240 V. The base unit may only be commissioned if the local mains voltage is within the voltage range of the system.
- The 2100 W power supply units may only be connected to 16 Amp grounding outlets or CEE outlets. When ordering the base unit, indicate the type of outlet available at the installation site. This will allow us to supply a cable with suitable inlet connectors for non-heating appliances with the order.

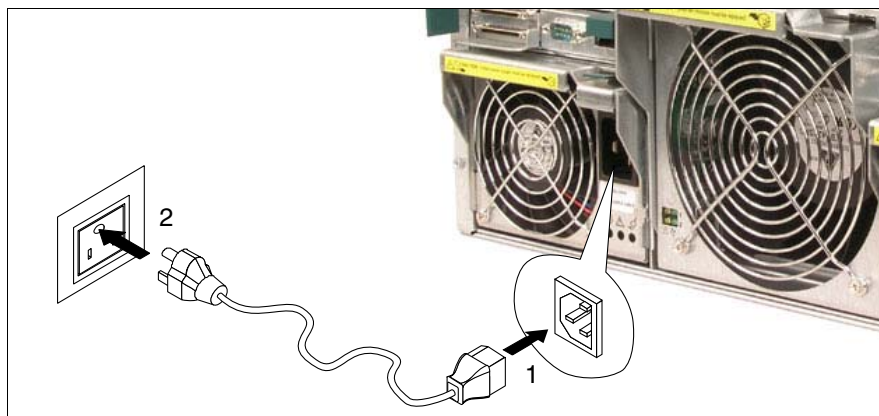

Figure 13: Connecting the basic unit to the mains

- ▶ First connect the insulated connector of the power cables to the power supply units of the basic unit (1), and then plug the power plug (2) into the USV, Power Distribution Unit (PDU) or into an external socket.



CAUTION!

Always connect the power cable to the power supply units first, and then to the mains.



Please make sure that each of the power supply units is connected to a different phase. This will provide you with additional phase redundancy for high availability configurations. If one phase has failed, the power supply units connected to the other phases keep active. You can get full phase redundancy with up to three power supply units. With four power supply units, two of them are to be connected to one phase (see also [“Related Publications” on page 165](#)).

Phase redundancy is possible in regions, where a single phase provides 200 - 240V; in other regions with lower single phase voltage, two phases must be coupled and complete phase redundancy thus is not possible.

5 Preparation for Use and Operation



CAUTION!

- Please note the safety instructions in the [chapter “Important Notes” on page 21](#).
- Beware of energy hazards on the plug-in contacts of the midplane. A short circuit on these connections can lead to damage to the system.

All unoccupied component slots are fitted with corresponding dummy modules to ensure that the electromagnetic emission properties of the system are observed and that the system components are cooled properly.



Figure 14: PRIMERGY BX600 S2 basic unit

5.1 Operating and Indicator Elements of the Basic Unit

5.1.1 The Front

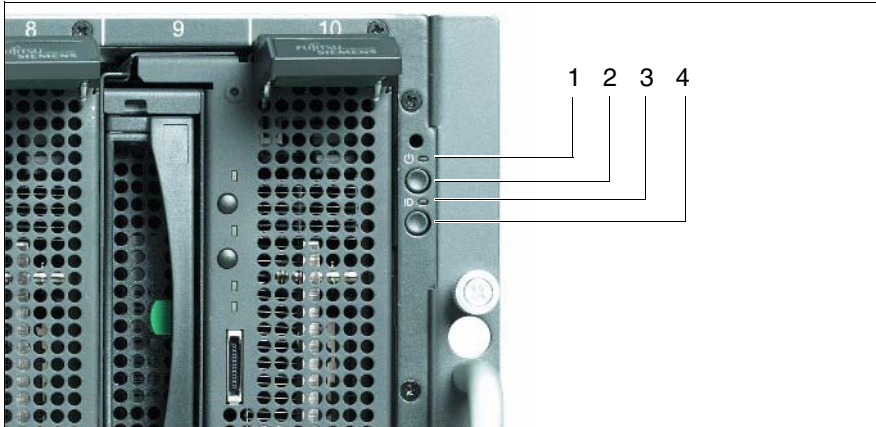



Figure 15: System operating and indicator elements on the front

<p>1</p>	<p>Power indicator (bicolor LED)</p> <p>Lights amber: basic unit is ready for powering ON (5 V standby power present).</p> <p>Lights green: basic unit is switched ON.</p>
<p>2</p> 	<p>System power ON/OFF button</p> <p>When the basic unit is switched OFF, pressing the power button for 2 seconds will switch it ON.</p> <p>When the basic unit is operating and the button is kept pressed for 4 seconds, the basic unit will be gracefully shut down.</p> <p>When the basic unit is switched ON, pressing the power button for 10 seconds will switch it OFF.</p>

3	<p>Front identify/Fault indicator (amber LED)</p> <p>Unlit: The system is normal and not highlighted. If power indicator LED lights green, basic unit is switched ON (5 V standby power present).</p> <p>Lights amber: This system has been selected by pressing the front or rear identify button. To deactivate, press one of the buttons again. You also can activate the LED via CLI.</p> <p>Blinks amber: The system is directly controlled via the management blade user interface.</p> <p>or</p> <p>SUM error: A malfunction has occurred in the system.</p>
4 ID	<p>Front identify button</p> <p>Pressing this button lights up the integrated front identify indicator. The front and rear identify indicators will be synchronized.</p>

5.1.2 The Rear

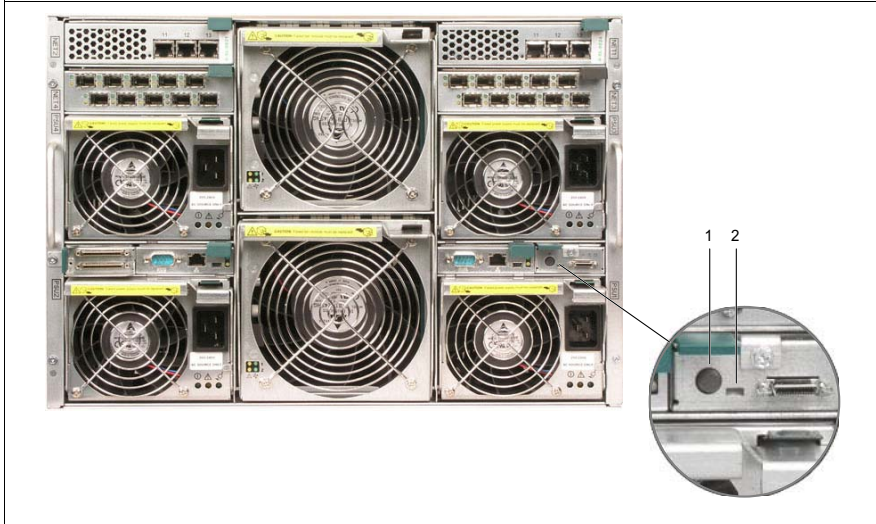

Figure 16: System operating and indicator elements on the rear

1	<p>Rear identify button¹</p> <p>Pressing this button lights up the rear identify indicator. The front and rear identify indicators will be synchronized.</p>
2	<p>Rear identify/Fault indicator (green LED)¹</p> <p>Lights green: This system has been selected for identification (identify LED is lit) by pressing the front or rear identify button.</p> <p>To deselect the system, press either of the identify buttons again.</p> <p>Blinks green: SUM error: A malfunction has occurred in the system.</p>

¹ Figure 16 shows the operator panel of the standard KVM blade. For further information on this KVM blade and on the adv. KVM blade, see [chapter "KVM Blade" on page 133](#).

5.2 Switching the Basic Unit ON/OFF



CAUTION!

- Make sure that the PRIMERGY BX600 S2 basic unit is connected to the mains for at least one minute before pressing the power ON/OFF button to switch the system ON.
- If, after switching the basic unit ON, you can only see flickering stripes on the attached monitor, switch the system OFF immediately (see [chapter “Troubleshooting and Tips” on page 155](#)).
- The system ON/OFF power button does not disconnect the system from the mains voltage. To completely disconnect it, you must remove the power plugs from the sockets.

Switching ON the Basic Unit (Basic Unit is Powered OFF)

- ▶ Press the basic unit power ON/OFF button (position 2 in [figure 15 on page 50](#)) for 2 seconds. Depending on the BIOS settings, the server blades can be switched on automatically one after another according to the slot numbering (see [figure 29 on page 72](#)).
- ▶ If necessary, switch ON the required server blades (see [“Switching the Server Blades ON/OFF” on page 54](#)).

The basic unit is switched ON and the activated server blades perform a system test and boot the operating system.

Switching OFF the Basic Unit (System is Powered ON)

The basic unit is operating (server blades are also switched ON).

- ▶ For **graceful shutdown** of all server blades, press the system power ON/OFF button (position 2 on [figure 15 on page 50](#)) for 4 seconds. The server blades will then be powered OFF.
- ▶ For **hard shutdown** of all server blades, press the system power ON/OFF button (position 2 on [figure 15 on page 50](#)) for 10 seconds. The server blades will be powered OFF immediately.

Other Ways to Switch ON the Basic Unit

- **Using the web interface of the management blade**

Using the web interface of the management blade, you can switch on the basic unit as well as each of the server blades.

- **After power failure**

The basic unit automatically switches ON following a power failure, and the server blades which were operating before the power failure are booted automatically.

Switching the Server Blades ON/OFF

The basic unit must be powered ON.

The server blade can be switched ON and OFF in the following ways:

- To switch ON the server blade, press the power button of the server blade (see the manual for the relevant server blade type).

To switch OFF the server blade, press the power button of the server blade (see the manual for the relevant server blade type) for 4 seconds.

- Specified **switch-ON time/switch-OFF time**

The server blade is switched ON or OFF at a time specified in the *ServerView* program.

- **Ring indicator**

The server blade is switched ON via an external modem.

- **After power failure**

The server blade automatically switches ON following a power failure (depending on the settings in the BIOS).

5.3 Management Blade Configuration

The two redundant management blades provide functionality for remote control of the PRIMERGY BX600 S2 base unit over the LAN (see [chapter "Management Blade" on page 125](#) and the „PRIMERGY BX Blade Server Systems: RemoteView Management Blade - User Interface Description“ manual). To commission the base unit, the LAN parameters of the management blades must be set using a local client computer.

To configure the management blade, follow the steps listed below.

Pre-Configuration Requirements

The procedures that follow assume that the basic unit is connected to the power line.

Cabling the System

- ▶ Connect the serial interface of the client (COM1) to the serial interface of the master management blade using an RS232 cable (null modem cable).



The master management blade is indicated by a green LED (see [section "Control and Connection Panel" on page 126](#)).

Initial Configuration via Serial Connection to Client

- ▶ Open a HyperTerminal session from the client to the master management blade. Use the following settings:

Bits per second	115200
Data bits	8
Parity	None
Stop bit	1
Flow control	None
Terminal type	VT100

Once you have opened the HyperTerminal session the welcome screen of the console menu will be displayed (see [figure 17](#) below).

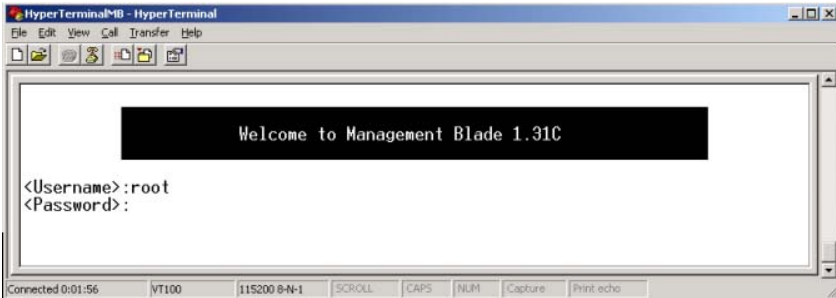

Figure 17: Welcome screen

- ▶ Log in as `root`. The initial password reads `root`.



CAUTION!

Change the root password as soon as possible (see [page 56](#)). Failure to do so may result in unauthorized access and loss of customer data.



You can change the root password of the management blade via menu item 6 (*Username and Password*) of the *Management Agent* menu (see [figure 19 on page 57](#)).

When you have logged on, the main menu of the console menu will be displayed.

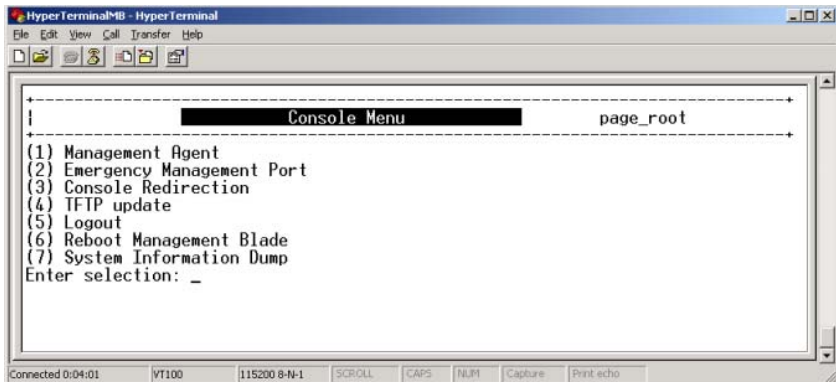

Figure 18: Console menu

- ▶ Enter 1 to call up the *Management Agent* menu.

The *Management Agent* menu looks like this:

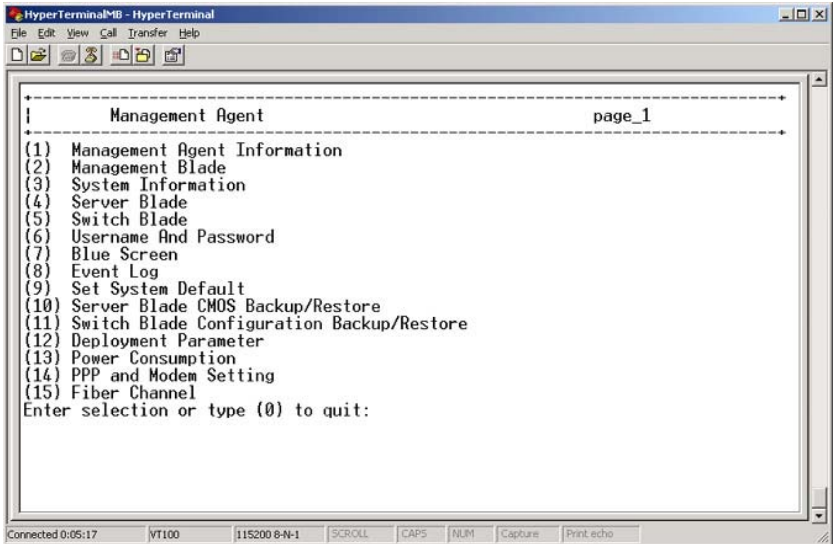

Figure 19: Management Agent menu.

- ▶ Enter 1 to call up the *Management Agent Information* menu.

The *Management Agent Information* menu provides access to the parameters required by the LAN connection.

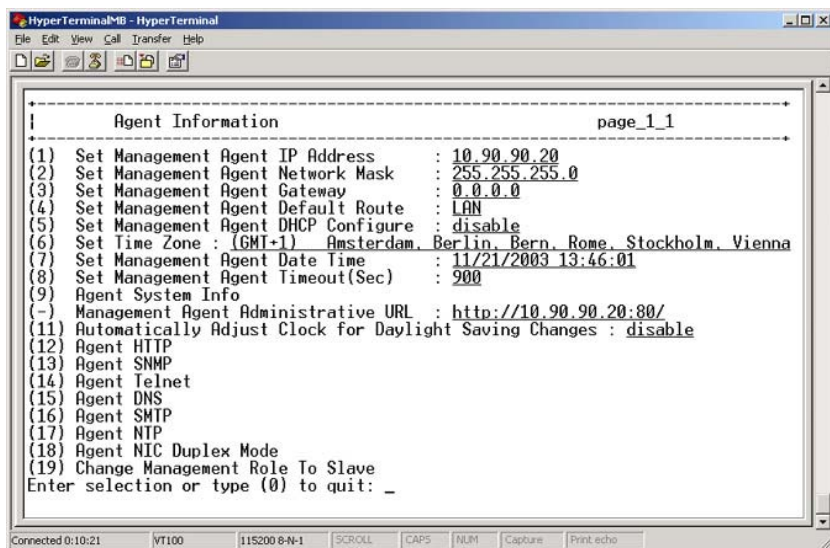

Figure 20: Management Agent Information menu

Follow the steps below to make the management blade accessible via the LAN.

- ▶ Select 1 to set the IP address of the management blade.
- ▶ Select 2 to enter the network mask of your subnet.
- ▶ Select 3 to enter the IP address of your gateway.
- ▶ Select 18 to call up the *Agent NTC Duplex Mode* menu.

- i The management blade LAN controller only runs at 10 Mbit/sec. Duplex mode must be defined manually via the *Agent NTC Duplex Mode* (see [figure 21](#) below).

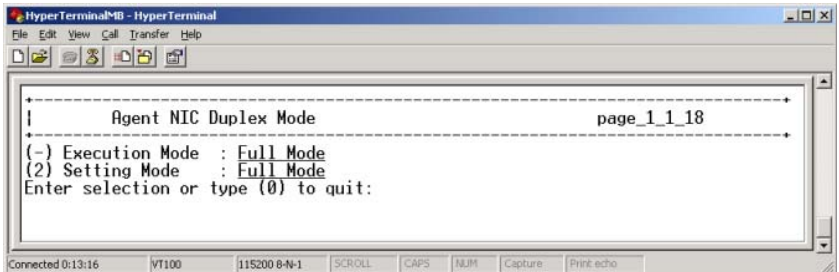

Figure 21: Agent NIC Duplex Mode menu

- ▶ Enter 2 if the preset duplex mode value needs to be altered or 0.
- i The transfer rate of 10 Mbit/sec and the duplex mode of the management blade must comply with the client LAN controller! Automatic synchronization is not supported by the management blade LAN controller.
- ▶ Enter 0 in this menu and in the preceding menus to leave the management blade console menu.
- ▶ Close the HyperTerminal session.
- ▶ Unplug the power cable from the basic unit and plug it in again to reboot the management blade.

- i This ensures that the management blade continues to act as the master after the restart. A restart without interruption to the power supply would cause the master/slave assignment to change.

The management blade can now be accessed via the LAN. For more information on the management blade configuration, see the manual "[PRIMERGY BX Blade Server Systems: RemoteView Management Blade - User Interface Description](#)". Information on the configuration of the various switch blade models can be found in separate manuals, see "[Related Publications](#)" on [page 165](#).

5.4 Updating System Components

All files required for updating the PRIMERGY BX600 S2 basic unit components are available from <http://www.fujitsu-siemens.com/support/downloads.html>.

5.4.1 Updating the Server Blade Firmware (BIOS and BMC)

You can update both the firmware of the server blade BIOS and the firmware of the server blade BMC.



BMC stands for **B**aseboard **M**anagement **C**ontroller. The BMC on the server blade collects management information and forwards it to the management blade.

There are two possible procedures for updating the firmware of the server blade BIOS and the server blade BMC:

- Updating the server blade firmware from a USB floppy drive
This procedure is described in the Operating Manual for the server blade (see “[Related Publications](#)” on page 165).
- Updating the firmware of the server blade with TFTP (see below).

Proceed as follows:

- ▶ Install your TFTP server software and start it.
- ▶ Download the TFTP update package *BX600 S2_TFTP-IMAGES_<version>.exe* from the Fujitsu Siemens download server <http://www.fujitsu-siemens.com/support/downloads.html>.
- ▶ Extract the desired BIOS and/or BMC firmware files to the root directory of the TFTP file system. For information on the image file names, see the *readme* file of the update package.
- ▶ Check the LAN connection by pinging the relevant server blade.
- ▶ Update the firmware of the server blade (BIOS and BMC).

You have two options for doing this:

1. In the management console (Telnet) select the *TFTP Update* submenu. The update process is similar to the process via the management blade web user interface (see below).

2. In the web interface of the management blade, select the menu *System Property–Environ./Maintenance–Firmware Update–Server Blade BMC* or *System Property–Environ./Maintenance–Firmware Update–Server Blade BIOS*



For security reasons the BIOS and BMC firmware can only be updated if the relevant server blade was shut down beforehand, otherwise the update option is not offered in the web menu.

Figure 22: Updating the server blade BIOS via the web interface

- ▶ In the *TFTP Server IP Address* field, enter the IP address of the TFTP server which provides the BIOS image file for the server blade firmware.
- ▶ In the *Boot Image File Name* field, enter the file name of the boot image file for the server blade.
- ▶ Use the *Add* and *Delete* buttons to select the server blades whose BIOS is to be updated.
- ▶ Click the *Apply* button. The update file is transferred to all selected server blades and the update process is started. The progress of the update process is shown in a status screen.
- ▶ Once the update process is complete, the server blade(s) is (are) restarted.
- ▶ Repeat the procedure to update the BMC firmware (see [figure 23](#)).

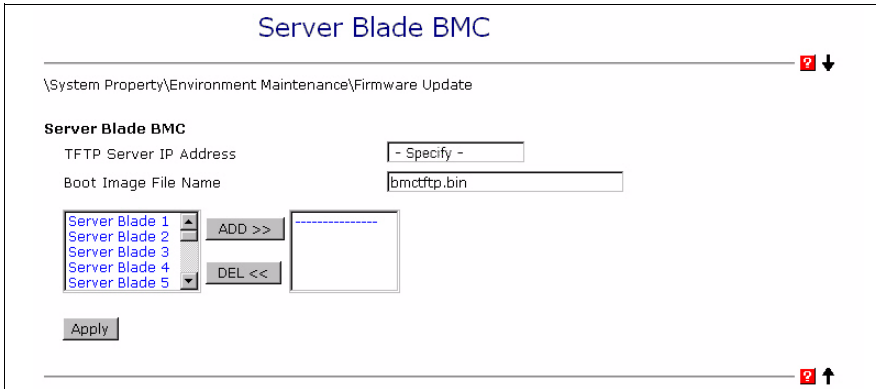

Figure 23: Updating the server blade BMC via the web interface

5.4.2 Updating the Management Blade Firmware



CAUTION!

The procedure described below must be performed for each of the two management blades.

Proceed as follows:

- ▶ Install your TFTP server software and start it. Copy the relevant firmware file (*.bin) to the root directory of the TFTP file system.
- ▶ Check the LAN connection by pinging the relevant management blade.
- ▶ Enter the IP address of the TFTP server which provides the BMC image file for the management blade firmware. Enter the path and the file name of the image file for the management blade.

You have two options for doing this:

1. In the management console (Telnet) select the *TFTP Upgrade* submenu. Activate the option *Management Blade/TFTP Update*.
2. In the web interface of the management blade, select the entry *System Property - Environment Maintenance - Firmware Update - Management Blade BMC Update*.

Management Blade

Management Blade BMC

TFTP Server IP Address

Agent Update IP Address

Boot Image File Name

TFTP Update Enable

Controller time: 03/09/2004 11:34:53
© 2000-2004 Fujitsu Siemens Computers

Figure 24: Updating the management blade firmware via the web interface

- ▶ Make sure that both management blades are connected to the LAN.
- ▶ Enter the IP address of the *TFTP* server on which the image file for the management blade firmware is provided.
- ▶ Enter an IP address in the *Agent Update IP Address* field.



The IP address in the *Agent Update IP Address* field is only used temporarily, so you can enter any IP address that is not used in the LAN segment of the server.

- ▶ In the *Boot Image File Name* field, enter the name of the image file of the management blade.
- ▶ Set the value of the *TFTP Update Enable* field to *enable*.
- ▶ Click *Apply*.

The firmware of the first management blade (*Master*) will now be updated (the green LED lights up). When the update process is complete, this management blade is defined as the *Slave*, and the second management blade, which used to be the *Slave*, is now defined as the *Master*.

- ▶ Repeat the update process for the second management blade.

After the update process for the second management blade, the original *Master-Slave* configuration is automatically restored.

5.4.3 Updating the Switch Blade Firmware



Before you update the firmware, you must allocate IP addresses to the individual switch blades.

Proceed as follows:

- ▶ Switch on the basic unit and start the management console (Telnet) of the management blade.

```
Console Menu page_root
-----
(1) Management Agent
(2) Emergency Management Port
(3) Console Redirection
(4) TFTP upgrade
(5) Logout
(6) Reboot Management Blade
(7) System Information Dump
Enter Selection: 3
```

- ▶ In the management blade console, select the menu item *Console Redirection*.

```
Console Redirection Table page_0.
-----
(1) Console Redirect Server Blade
(2) Console Redirect Switch Blade
(3) Set Return Hotkey , Ctrl+(a character) : 0
Enter selection or type (0) to quit: 2
```

- ▶ In the *Console Redirection Table* menu, select the menu item *Console Redirect Switch Blade*.

```
Console Redirection Switch Blade
```

```
page_3_2.
```

```
(1) Console Redirect Switch Blade_1
(2) Console Redirect Switch Blade_2
Enter selection or type (0) to quit: 1
```

- ▶ Enter the desired switch blade.

The command line interface session starts.

```
Press <Ctrl-Q> Return Console Menu
```

- ▶ Press the *Return* key to switch to command mode.

Command mode is indicated by the prompt `Console#`.

```
CLI session with the Switch Blade is opened.
To end the CLI session, enter [Exit].
```

```
Condole>enable
Console#config
Console(config)#interface vlan 1
Console(config-if)#ip address 10.50.50.51 255.0.0.0
Console(config-if)#exit
Console#show ip interface
TP address and netmask: 10.50.50.51 255.0.0.0 on VLAN 1,
and address mode: User specified

Console#
```

- ▶ Enter the commands specified above.



The specifications for the IP address and the subnet mask are merely examples and are probably not valid for your system.

- ▶ Terminate the command line session by pressing `[Strg] [Q]`.
- ▶ Check the newly created LAN connection by pinging the switch blade on the client system.
- ▶ Install your TFTP server software and start it.
- ▶ Download the TFTP update package `BX600 S2_TFTP-IMAGES_<version>.exe` from the Fujitsu Siemens download server at <http://www.fujitsu-siemens.com/support/downloads.html>.

- ▶ Extract the firmware file (*.bix) to the root directory of the TFTP file system. For information on the image file names, see the *readme* file of the update package.
- ▶ Start an Internet browser on the client server. Enter the IP address specified above in the address field. Enter the user name and password admin. The home page is displayed.
- ▶ In the navigation bar choose *Flash/File*.

i Only two operation code image files can be stored on the switch blade. If there are already two image files stored, you must remove at least one of them before updating the firmware. It is recommended that you remove the older file (i.e. the file with the lower number).

- ▶ Expand the *File Name* list (red arrow) in the *Remove Operation Code Image File* section to check if there are already two image files stored on the switch blade. If so, select the older one in the *File Name* list and click *Remove File*.

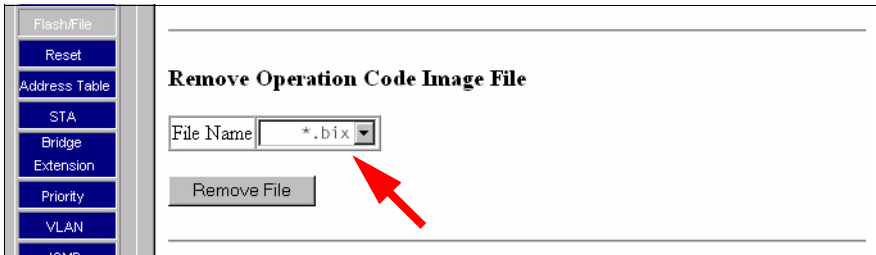

Figure 25: Removing an operation code image file

- ▶ Enter *TFTP Server IP Address*, *Source File Name (*.bix)* and *Destination File Name*.

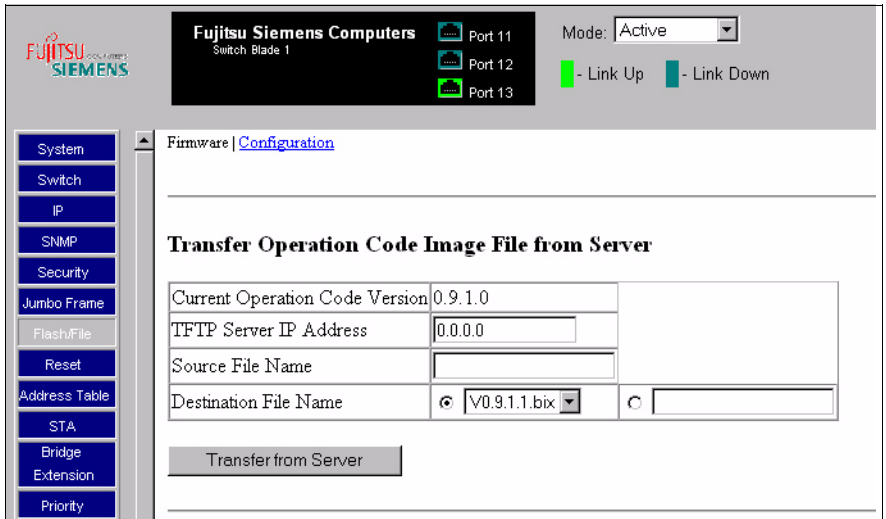

Figure 26: Transferring the new operation code image file

- ▶ Click *Transfer from Server*.
- ▶ Wait a few minutes until the update process is complete. Refresh the browser for viewing.
- ▶ Select the new image file in the pop-up window (red arrow) and click *Apply Changes*.

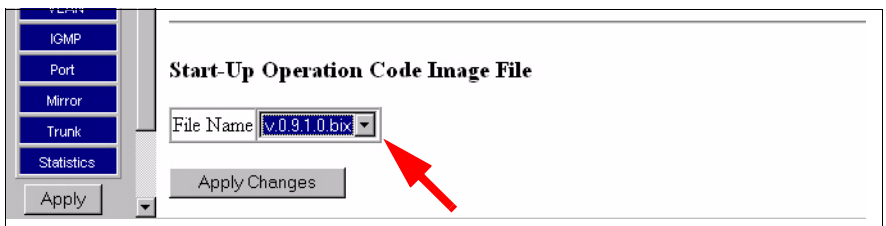

Figure 27: Selecting Start-Up Operation Code Image File

- ▶ Select *Reset* in the navigation bar.
- i** After resetting, the switch blade will reboot. However, all settings specified previously (IP address etc.) will be lost and must be reentered on the management console.
- ▶ Repeat the firmware update procedure for each installed switch blade.

6 Property and Data Protection

The lockable rack door protects the server against unauthorized access.

To protect your system and data internally against unauthorized access, you can use the *BIOS Setup* security functions.

Further security options can also be set in the installed operating system. If you wish to do this, consult your network administrator or refer to the documentation for the corresponding operating system.

6.1 BIOS Setup Security Functions

The *Security* menu in *BIOS Setup* offers various options for protecting data against unauthorized access. By combining these options, you can achieve optimum protection for the system.



A detailed description of the *Security* menu and how to assign passwords can be found in the manual for the *BIOS Setup* and on the ServerBooks CD (see also [“Related Publications” on page 165](#)).

Preventing Unauthorized BIOS Setup Calls

This protection mechanism can be activated by setting a supervisor password in the *Security* menu. In addition, the `Press F2 for Setup` message in the *Security* menu can be suppressed. This message is then no longer displayed while the server's startup routine is in progress.

Preventing Unauthorized System Access

This protection mechanism can be activated by setting a user password in the *Security* menu.

Preventing Unauthorized Boot Process

This protection mechanism can be activated by setting a password on boot in the *Security* menu.

7 Server Blades

This chapter describes how to install and uninstall server blades and server blade dummy modules in the PRIMERGY BX600 S2 basic unit, and what you need to be aware of when doing this.

The information necessary for installing and operating the various server blade models can be found in separate manuals (see [“Related Publications” on page 165](#)).

When you install a server blade in the basic unit, an important factor is the height. Figure 28 shows a 2-way server blade, which occupies one slot in the basic unit.



Figure 28: PRIMERGY BX620 S3/S4 2-way server blade

The 4-way server blade is twice the height and occupies two slots (figure 29).



Figure 29: PRIMERGY BX630 scalable server blade (4-way configuration)

7.1 Installation Sequence

On the front of the PRIMERGY BX600 S2 basic unit are ten slots for server blades (numbered 1 - 10 from left to right).

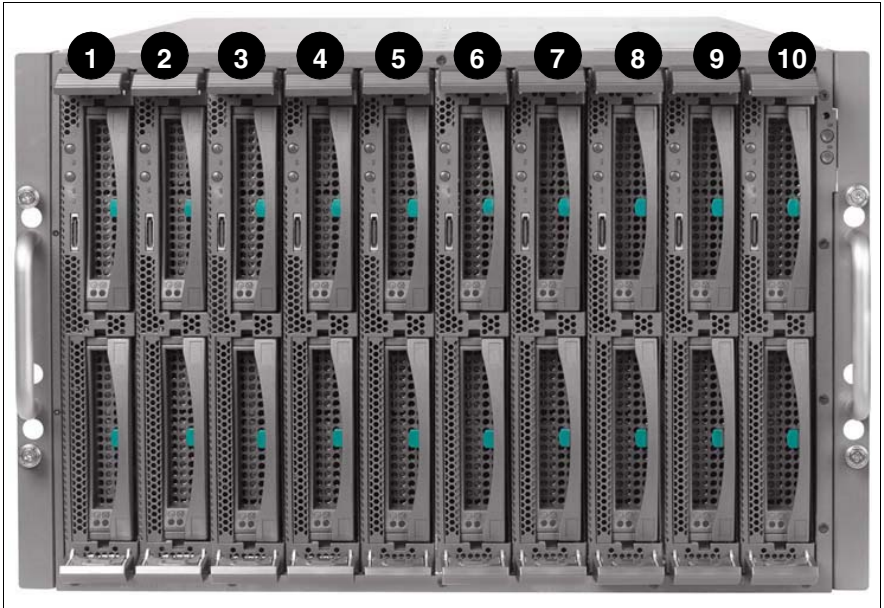

Figure 30: BX600 S2 basic unit with ten 2-way server blades

All ten slots are connected to the infrastructure modules on the back of the BX600 S2 basic unit via the midplane of the BX600 S2 basic unit:

- Switch blade(s)
- Fibre Channel pass-thru blade(s) (optional)
- Ethernet pass-thru blade(s) (optional)
- Management blade(s)
- KVM blade
- Power supply units



CAUTION!

PRIMERGY BX620 S4 server blades are not for use in slots 4 and 10 of the PRIMERGY BX600 S2 basic unit.

In a PRIMERGY BX600 S2 basic unit different models and configurations of server blades can be operated alongside each other.

The order in which the server blade slots are filled depends on whether you are using 2-way server blades or 4-way server blades or a mix of the two, and how the server blades are equipped.

Configuration Diagram for 2-way Server Blades

- Slot 4 is filled first.
- Next, slots 5 through 10 are filled in numerical order, followed by slots 1 through 3.
- 2-way server blades with SCSI controller in a PCI extension module can only be installed in slots 5 and 6 because of the cabling arrangement in the rack (see [section “Cable Routing” on page 43](#)).

1	2	3	4	5	6	7	8	9	10
8	9	10	1	2	3	4	5	6	7

Figure 31: Installation sequence for 2-way server blades

Configuration Diagram for 4-way Server Blades

- Slots 3 and 4 are filled first.
- Next, slots 5 through 10 are filled in pairs in numerical order, followed by slots 1 and 2.

1	2	3	4	5	6	7	8	9	10
5		1		2		3		4	

Figure 32: Installation sequence for 4-way server blades

Configuration Diagram for a Mix of 2-way and 4-way Server Blades

- The 4-way server blades are fitted first, followed by the 4-way server blades
- Begin with a 4-way server blade in slots 3 and 4.

1	2	3	4	5	6	7	8	9	10
6	Dummy server blade	1		2		3		4	5

Figure 33: Installation sequence for three 2-way and three 4-way server blades

i 2-way server blades with SCSI controller can only be fitted in slots 5 and 6. If only one 2-way server blade with SCSI controller is to be fitted, it must go in slot 5, with a dummy server blade in slot 6.

Configuration Diagram for a Mix of an 8-way Server Blade with 4-way and 2-way Server Blades

Begin with the 8-way server blade in slots 1-4, followed by the 4-way Server-Blades and the 2-way Server-Blades.



Server blades with SCSI controller can only be fitted in slots 5 and 6.

1	2	3	4	5	6	7	8	9	10
1				2		3		4	5

Figure 34: Installation sequence for an 8-way, two 4-way and two 2-way server blades

7.2 Adding a Server Blade to the Basic Unit

Depending on the desired configuration, the system can be upgraded with up to 10 server blades.



CAUTION!

- Read the safety information and the information on handling electrostatic-sensitive components in the [section “Components With Electrostatic-Sensitive Devices”](#) on page 25.
- Energiegefahr - neu.

Removing the Dummy Module

All unoccupied slots in the basic unit are fitted with dummy modules to ensure that the electromagnetic emission properties of the system are observed and that the system components are properly cooled.

If you want to add a server blade, you must first remove the dummy module from the corresponding slot.

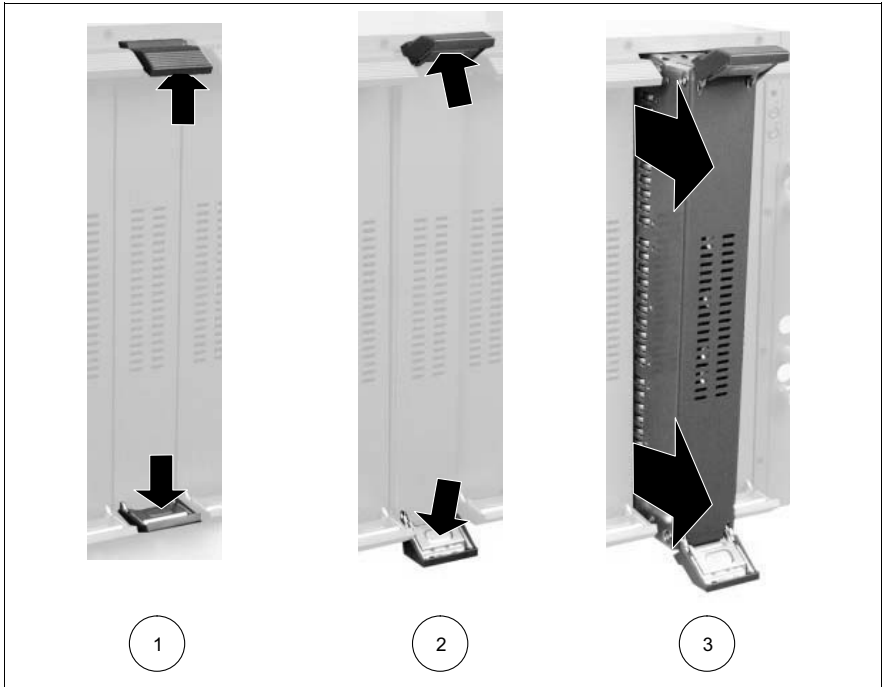

Figure 35: Removing a server blade dummy module

- ▶ Release the locking mechanism of the ejecting handles by pressing the touch points on the inside of both handles (1) simultaneously. The ejecting handles of the dummy module will be disengaged.
- ▶ Swing up the upper handle and swing down the lower handle simultaneously (2) until the locking mechanism of the dummy module disengages and the dummy module ejects.
- ▶ Remove the dummy module completely from the slot (3).



CAUTION!

Keep the dummy module for future use. If the server blade is removed and not replaced with a new server blade, then the dummy module must be reinstalled for cooling, to comply with the applicable EMC regulations (regulations on electromagnetic compatibility) and for fire protection.

Installation is the same as for the server blade (see [“Inserting the Server Blade” on page 78](#)).

Inserting the Server Blade



CAUTION!

Read the safety information and the information on handling electrostatic-sensitive components in the [section “Components With Electrostatic-Sensitive Devices” on page 25](#).



Figure 36: Turning the eject handles into the unlocked position (2-way server blade)

- ▶ Press the touch points on the inside of the eject handles (1) of the server blade to disengage the locking mechanism of the handles.
- ▶ Turn the eject handles outward (2) into the unlocked position.

The 4-way server blade has the same locking mechanism (see [figure 37](#)).



Figure 37: Turning the eject handles into the unlocked position (4-way server blade)



How to install a server blade is described in the following using the example of a 2-way server blade. 4-way server blades are installed in the same way.

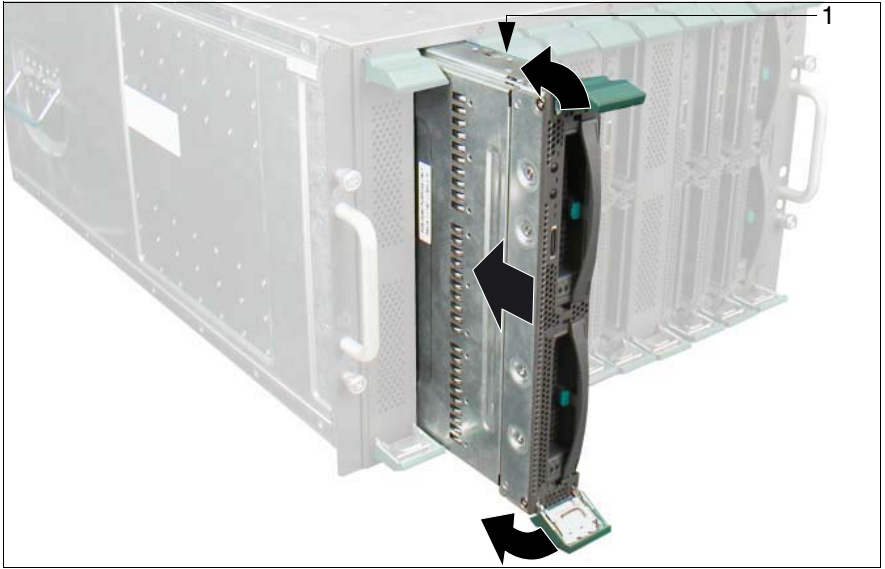

Figure 38: Inserting the server blade

- ▶ Push the server blade into the slot as far as possible while keeping the eject handles in the unlocked position.



Please make sure you install the server blade in the right direction. The upper narrow side of the server blade is marked **TOP-SIDE** (1).

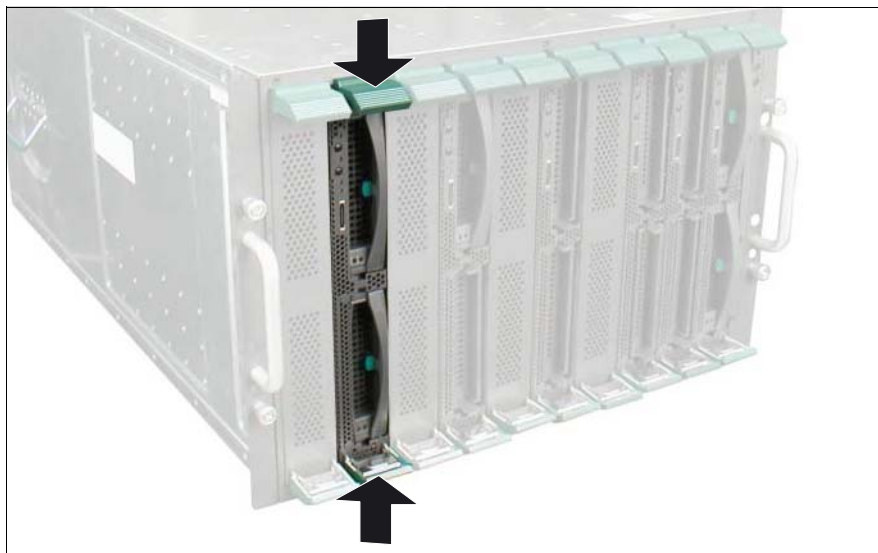

Figure 39: Final engaging of the locking mechanism

- ▶ Press the eject handles to enable the locking mechanism to engage fully.

Removing the Server Blade

The server blade is removed in the same way as the dummy module (see [“Removing the Dummy Module” on page 76](#)).



CAUTION!

Read the safety information and the information on handling electrostatic-sensitive components in the [section “Components With Electrostatic-Sensitive Devices” on page 25](#).

When you remove the server blade and do not replace it with a new one, you must insert a dummy module in the empty slot. Make sure that the dummy module engages in the slot correctly.

8 Ethernet LAN Switch Blades

This chapter outlines the main features of the switch blades available with the PRIMERGY BX600 S2 blade server. For each switch blade it describes the indicator and connection elements of the control and connection panel. This chapter also describes the port assignment to the server blades and how to install and uninstall the switch blades in the basic unit.

The information necessary for configuring and operating the various switch blade models can be found in separate manuals, see [“Related Publications” on page 165](#)).

The following switch blade models are available:

- [Gbit Ethernet LAN Switch Blade \(SB9\) 6x1Gbit](#)
- [Gbit Ethernet LAN Switch Blade \(SB9\) 6x1 Gbit + 2x10 Gbit](#)
- [Cisco Catalyst Blade Switch 3040](#)
- [10 Gbit Switch Blade 10/2](#)

8.1 Gbit Ethernet LAN Switch Blade (SB9) 6x1Gbit

The Gbit Ethernet LAN switch blade (SB9) 6x1Gbit supports layer 2/3/4 functionality and offers the following connections:

- 10 internal 1Gbit downlink ports to the server blades
- 6 external 1Gbit uplink ports via RJ45 connectors

Operating and Indicator Elements

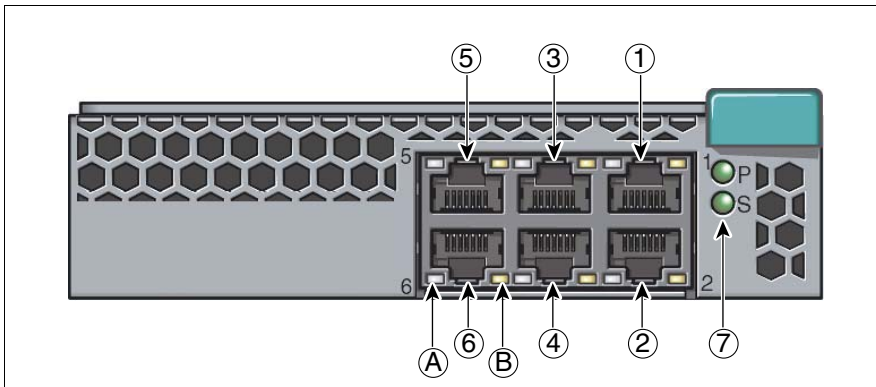

Figure 40: Gbit Ethernet LAN switch blade(SB9) 6x1Gbit

1-6	<p>1 Gbit uplink LAN connectors (with two integrated LAN status LEDs each)</p> <p>LED A: LAN active indicator (bicolor LED)</p> <p>Glows amber: Port link at 1 Gbit/s</p> <p>Glows green: Port link at 100 Mbit/s</p> <p>Dark: Port link at 10 Mbit/s</p> <p>LED B: LAN link indicator (yellow LED)</p> <p>Glows yellow: Network link</p> <p>Blinks yellow: Network activity</p> <p>Dark: No network link or port disabled</p>
-----	---

7 Power and system indicators (green LEDs)**P: Power indicator (green LED)**

Glows green: Power enabled

Dark: Power disabled

S: System indicator (green LED)

Glows green: Selected for identification by the management blade

Blinks green: Error occurred

The information necessary for configuring and operating the Gbit Ethernet LAN switch blade (SB9) 6x1Gbit can be found in the manual „PRIMERGY BX Blade Server Systems: LAN Router and Switch Blade - User Interface Description“, see [“Related Publications” on page 165](#)).

8.2 Gbit Ethernet LAN Switch Blade (SB9) 6x1 Gbit + 2x10 Gbit

The Gbit Ethernet LAN switch blade (SB9) 6x1 Gbit + 2x10 Gbit supports layer 2/3/4 functionality and offers the following connections:

- 10 internal 1Gbit downlink ports to the server blades
- 6 external 1Gbit uplink ports via RJ45 connectors
- 2 external 10-Gbit uplink ports via XFP module and corresponding fibre optic cable and CX4 connector and corresponding copper cable.

Operating and Indicator Elements

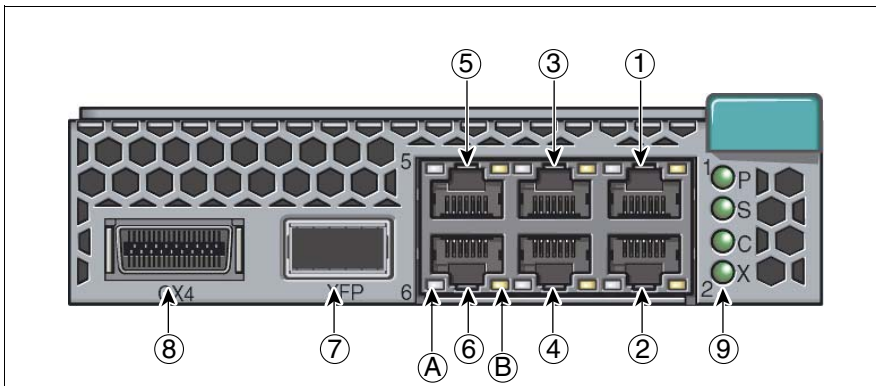

Figure 41: Gbit Ethernet LAN switch blade (SB9) 6x1 Gbit + 2x10 Gbit

1-6	<p>1 Gbit uplink LAN connectors (with two integrated LAN status LEDs each)</p> <p>LED A: LAN active indicator (bicolor LED)</p> <p>Glows amber: Port link at 1 Gbit/s</p> <p>Glows green: Port link at 100 Mbit/s</p> <p>Dark: Port link at 10 Mbit/s</p> <p>LED B: LAN link indicator (yellow LED)</p> <p>Glows yellow: Network link</p> <p>Glows yellow: Network activity</p> <p>Dark: No network link or port disabled</p>
7	10 Gbit XFP connector
8	10 Gbit CX4 connector

9	<p>Power, system and 10 GbE status indicators (green LEDs)</p> <p>P: Power indicator (green LED) Glows green: Power enabled Dark: Power disabled</p> <p>S: System indicator (green LED) Glows green: The switch has been selected for identification by the management blade. Blinks green: Error occurred</p> <p>C: CX4 link/active indicator (green LED) Glows green: CX4 network link Blinks green: CX4 port port</p> <p>X: XFP link/active indicator (green LED) Glows green: XFP network linkr Blinks green: XFP port link</p>
---	--

The information necessary for configuring and operating the Gbit Ethernet LAN switch blade (SB9) 6x1 Gbit + 2x10 Gbit can be found in the manual „PRIMERGY BX Blade Server Systems: LAN Router and Switch Blade - User Interface Description“, see [“Related Publications” on page 165](#)).

8.3 Cisco Catalyst Blade Switch 3040

The Cisco Catalyst Blade Switch 3040 provides the following features:

- 10 internal 1Gbit downlink ports to the server blades
- 1 console port
- 2 external 10/100/1000BASE-T copper Gigabit Ethernet uplink ports
- 4 external small form-factor pluggable (SFP) module uplink ports that support 1000BASE-SX fiber and 10/100/1000BASE-T copper (only Cisco SFP modules are supported)

Operating and Indicator Elements

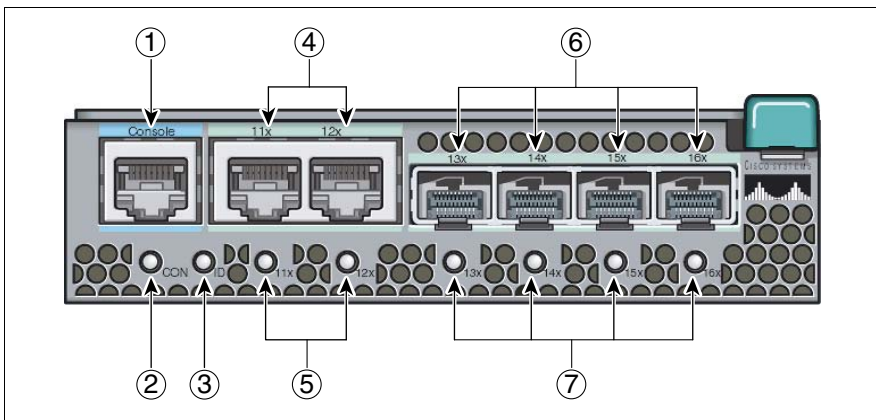

Figure 42: Cisco Catalyst Blade Switch 3040

1	Console port
2	<p>Console port indicator (bicolor LED)</p> <p>Dark: The bootloader is initializing.</p> <p>Glows green: The blade switch console port is active.</p> <p>Glows amber: The blade switch console port is inactive; the management blade/backplane console is active.</p> <p>Glows green or amber: Cisco IOS is operating normally.</p>
3	<p>System status/ID indicator (green LED)</p> <p>Glows green: ID- The switch has been selected for identification by the management blade.</p>

4	Gigabit Ethernet ports
5	<p>Gigabit Ethernet port indicators (bicolor LEDs)</p> <p>Dark: No link established.</p> <p>Glow green: Link established but no activity.</p> <p>Blinks green: Traffic on an established link.</p> <p>Glow amber: Port disabled, either error or STP1 disabled.</p> <p>Glow green or amber: Link fault.</p>
6	SFP module ports
7	<p>SFP module port indicators (bicolor LEDs)</p> <p>Dark: No link established.</p> <p>Glow green: Link established but no activity.</p> <p>Blinks green: Traffic on an established link.</p> <p>Glow amber: Port disabled, either error or STP1 disabled.</p> <p>Glow green or amber: Link fault.</p>

The information necessary for configuring and operating the Cisco Catalyst Blade Switch 3040 can be found in the manual „PRIMERGY BX Blade Server Systems: Cisco Catalyst Blade Switch 3040“, see [“Related Publications” on page 165](#)).

8.4 10 Gbit Switch Blade 10/2

The 10 Gbit switch blade 10/2 is designed to transport all blade server I/O, including network and storage, between the server blades and their associated I/O devices. The 10 Gbit switch blade 10/2 provides the following features:

- 10 internal 10 Gbit/s ports to the server blades
- 2 external 10 Gbit/s ports with optional X2 transceiver modules for Fiber optical or CX4 copper cable
- 1 console port



CAUTION!

- You may install 10 Gbit switch blades 10/2 only in slots NET3 and NET4 of the basic unit, see [figure “Slots for the switch blades” on page 90](#).
- The 10 Gbit switch blade 10/2 only supports server blades with a 10 GbE daughter card installed. 10 GbE daughter cards can be installed in server blades BX620 as of version S3 and BX630 as of version S2.

Bedien- und Anschlussfeld

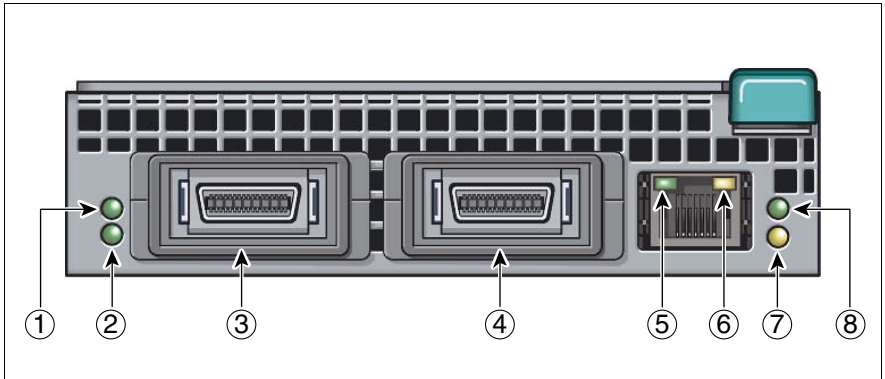

Figure 43: 10 Gbit Switch Blade 10/2

1	<p>Left CX4 port indicator (green LED)</p> <p>Glow: CX4 link established</p> <p>Blink: CX4 link active</p>
1	<p>Right CX4 port indicator (green LED)</p> <p>Glow: CX4 link established</p> <p>Blink: CX4 link active</p>
3,4	<p>CX4 ports</p>
5	<p>Console port link indicator (green LED)</p> <p>Glow: Link available</p>
6	<p>Console port active indicator (amber LED)</p> <p>Dark: 1 Gbit/s link available</p> <p>Glow: 100 Mbit/s link available</p> <p>Blink: Link active</p>
7	<p>Power indicator (amber LED)</p> <p>Dark: Power enabled</p> <p>Glow: Power disabled</p>
8	<p>ID indicator (green LED)</p> <p>Glow: Switch blade is operating</p> <p>Blink: The switch blade has been selected for identification by the management blade.</p>

8.5 Port Assignment of the LAN Switch Blades

For each of the ten server blade slots, connections are available to the two ports of the onboard LAN controllers and to the two ports of the optional gigabit Ethernet daughter card. In the case of 4-way server blades, connections for a total of eight LAN ports are therefore available.

The LAN switch blade in the NET1 slot is connected to port A of the onboard LAN controller of the installed server blades. The switch blade in slot NET2 is connected to port B of the onboard LAN controller. In the same way, the LAN switch blades in slots NET3 and NET4 are connected to port A and B of the gigabit Ethernet daughter cards.

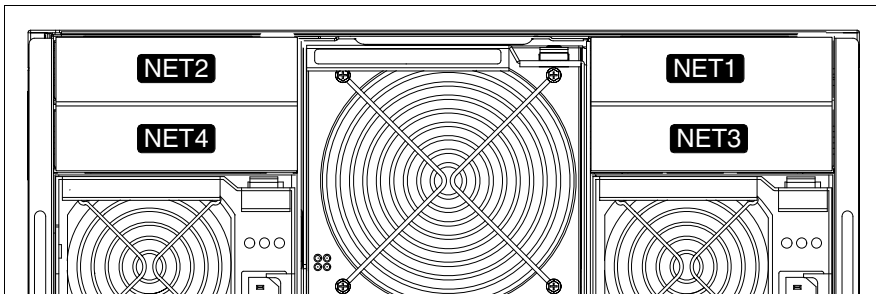

Figure 44: Slots for the switch blades

The installation of two LAN switch blades in NET1 and NET2 (or NET3 and NET4) enables redundant LAN connections to be provided for the relevant LAN controllers of the server blades.



CAUTION

- LAN switch blades must always be installed in slots NET1 and NET3 first. This ensures that port A of the relevant LAN controller is connected if redundant LAN connections are not used.
- To provide fibre channel functionality, FC pass-thru blades (see [page 113](#)) or FC switch blades (see [page 105](#)) must be installed in slot NET3 and/or slot NET4.

Asynchronous balanced mode of Ethernet blades and fibre channel blades in slots NET3 and NET4 is not permitted.

The configuration examples below show the assignment of the onboard LAN controller ports to the LAN switch blades in slots NET1 and NET2. The port assignment for the gigabit Ethernet daughter cards to the LAN switch blade ports in slots NET3 and NET4 takes place accordingly.

Configuration with Ten 2-way Server Blades

The following figure illustrates the assignment of the switch blades to the LAN ports of the server blades in a configuration with ten 2-way server blades.

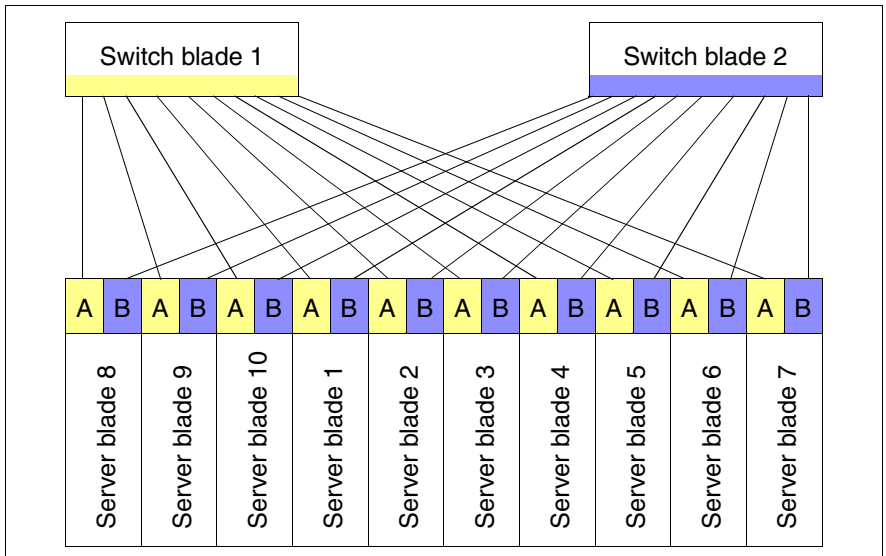

Figure 45: LAN port assignment with ten 2-way server blades

Configuration with Five 4-way Server-Blades

The following figure illustrates the assignment of the switch blades to the LAN ports of the server blades in a configuration with five 4-way server blades.

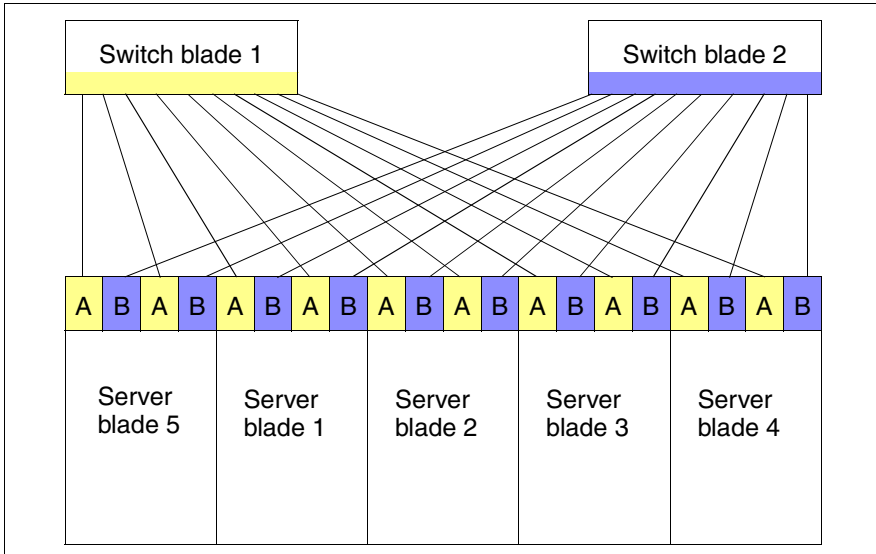

Figure 46: LAN port assignment with five 4-way server blades

Configuration with a Combination of 2-way and 4-way Server Blades

The following figure illustrates the assignment of the switch blades to the LAN ports of the server blades in a configuration with two 4-way server blades and six 2-way server blades.

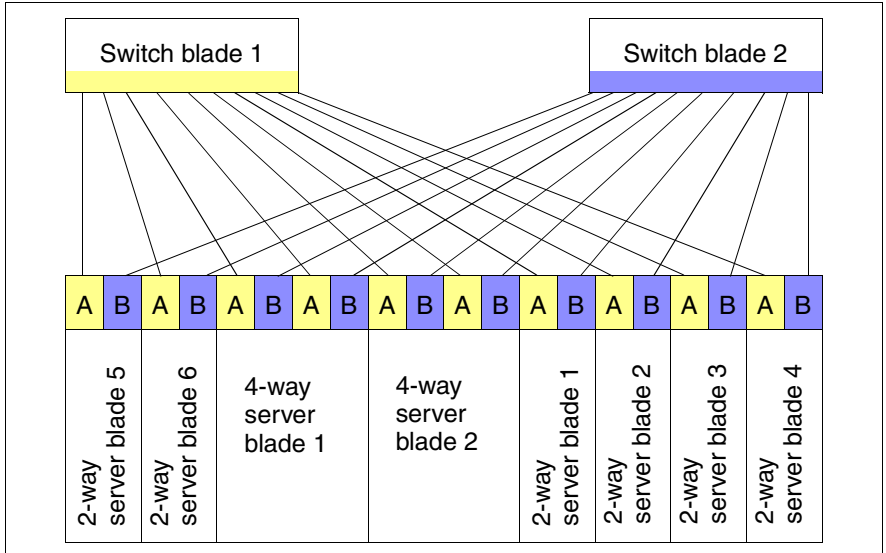

Figure 47: LAN port assignment with 4-way and 2-way server blades

8.6 Installing a LAN Switch Blade

Depending on the desired configuration, the system can be upgraded with one additional switch blade.



CAUTION!

- Read the safety information and the information on handling electrostatic-sensitive components in the [section “Components With Electrostatic-Sensitive Devices” on page 25](#).
- LAN switch blades must always be installed in slots NET1 and NET3 first (see [page 90](#)).

Removing the Dummy Module

All unoccupied slots in the basic unit are fitted with dummy modules to ensure that the electromagnetic emission properties of the system are observed and that the system components are properly cooled.

If you wish to install a LAN switch blade, you must first remove the dummy module from the corresponding slot.

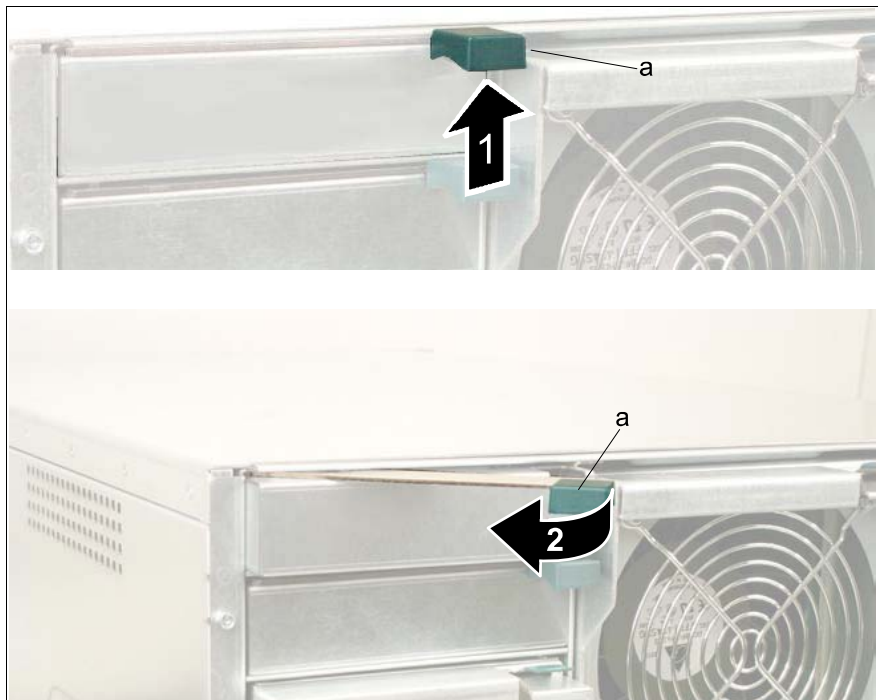

Figure 48: Removing the dummy module (a = green touch point)

- ▶ Press the spring (1) on the underside of the handle (a) to unlock it.
- ▶ Swing the handle (a) in the direction of the arrow (2) until the locking mechanism of the dummy module disengages.



Figure 49: Removing the dummy module (a = green touch point)

- ▶ Remove the dummy module from the slot (2).



CAUTION!

Keep the dummy module for future use. If you remove the LAN switch blade and do not replace it with a new one, you must reinstall the dummy module.

Installation is the same as for the LAN switch blade (see [“Inserting the LAN Switch Blade” on page 95](#)).

Inserting the LAN Switch Blade



CAUTION!

Read the safety information and the information on handling electrostatic-sensitive components in the [section “Components With Electrostatic-Sensitive Devices” on page 25](#).

- ▶ Remove the LAN switch blade from its package.



Figure 50: Disengaging the switch blade

- ▶ Disengage the locking mechanism of the LAN switch blade by swinging the handle in the direction of the arrow.

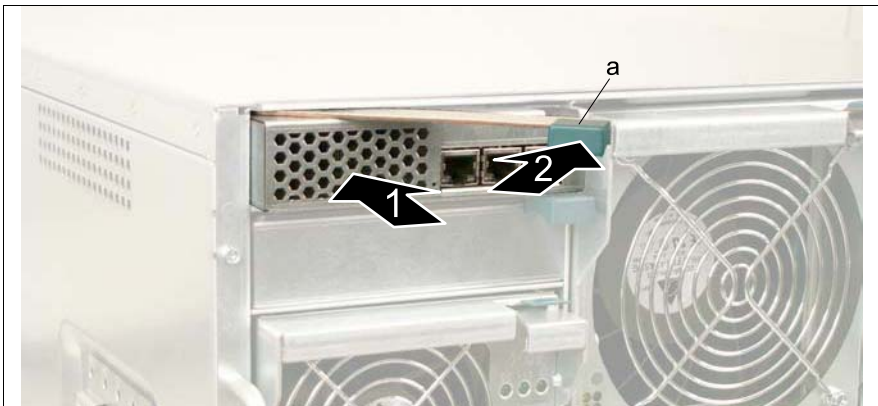

Figure 51: Inserting the switch blade (a = green touch point)

- ▶ Push (1) the LAN switch blade as far as possible into the desired slot (here slot 2).
- ▶ Swing up (2) the eject handle (a) of the switch blade until the locking mechanism of the LAN switch blade engages.

Removing the Switch Blade

The LAN switch blade is removed in the same way as the dummy module (see [“Removing the Dummy Module” on page 94](#)).



CAUTION!

Read the safety information and the information on handling electrostatic-sensitive components in the [section “Components With Electrostatic-Sensitive Devices” on page 25](#).

If you remove the LAN switch blade and do not replace it with a new one, you must insert a dummy module in the empty slot to ensure cooling, to comply with the applicable EMC regulations (regulations on electromagnetic compatibility) and for fire protection.

Make sure that the dummy module engages in the slot correctly.

9 Ethernet Pass-Thru Blade

The Ethernet LAN Pass-Thru-Blade provides ten RJ45 ports for direct (“pass-thru”) connections to the server blades.



Figure 52: Ethernet LAN Pass-Thru-Blade

The PRIMERGY BX600 S2 basic unit offers slots for up to four Ethernet LAN Pass-Thru-Blades on the back, see [figure 54 on page 101](#). Depending on the specific slot, an Ethernet LAN Pass-Thru-Blade establishes connections to the onboard LAN controllers or to the optional Gigabit Ethernet I/O modules (daughter cards) of the server blades. For information on the optional Gigabit Ethernet I/O modules (daughter cards), see the operating guides for the relevant server blade types.

9.1 Control and Connection Panel

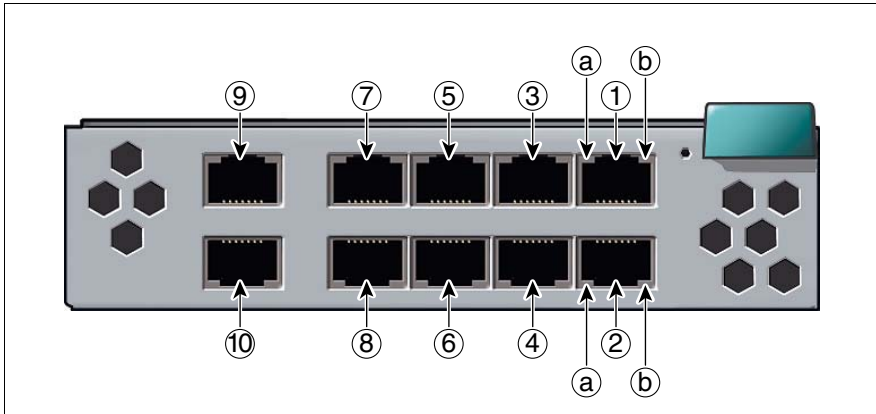

Figure 53: Control and connection panel of the Ethernet LAN Pass-Thru-Blade

The following display and control elements are available:

<p>1 ... 10</p>	<p>RJ45 connectors</p> <p>The RJ45 connectors are assigned to the server blades in accordance with their numbering (for server blade slot numbering see figure 30 on page 73).</p>
<p>a</p>	<p>LAN activity indicator (orange LED)</p> <p>Blinks Active LAN connection amber:</p> <p>Dark Inactive LAN connection</p>
<p>b</p>	<p>LAN connection indicator (green LED)</p> <p>Lights green: LAN connection available Dark No LAN connection</p>

9.2 Port Assignment of the Gigabit Ethernet Pass-Thru Blades

The PRIMERGY BX600 S2 basic unit offers four slots for Ethernet LAN Pass-Thru-Blades on the back.

The Ethernet LAN Pass-Thru-Blade in slot NET1 is connected to port A of the onboard LAN controller of the installed server blades. The Ethernet LAN Pass-Thru-Blade in slot NET2 is connected to port B of the onboard LAN controller. In the same way, the Ethernet LAN Pass-Thru-Blades in slots NET3 and NET4 are connected to port A and B of the gigabit Ethernet daughter cards.

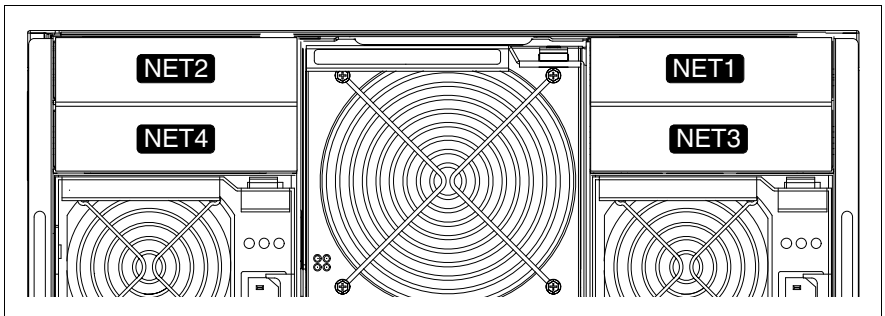

Figure 54: Slots for installing pass-thru blades

The installation of two Ethernet LAN Pass-Thru-Blades in NET1 and NET2 (or NET3 and NET4) enables redundant LAN connections to be provided for the relevant LAN controllers of the server blades.



CAUTION

- Components must always be installed in slots NET1 and NET3 first. This ensures that port A of the relevant LAN controller is connected if redundant LAN connections are not used.
- To provide fibre channel functionality, FC pass-thru blades (see [page 113](#)) or FC switch blades (see [page 105](#)) must be installed in slot NET3 and/or slot NET4.

Asynchronous balanced mode of Ethernet blades and fibre channel blades in slots NET3 and NET4 is not permitted.

The following configuration examples show the assignment of the Ethernet ports of the pass-thru blades to the server blades.

Configuration with Ten 2-way Server Blades

A PRIMERGY BX6xx dual server blade offers an onboard LAN controller with two LAN channels and a slot for an optional Gigabit Ethernet I/O module with two extra LAN channels.

The Ethernet LAN Pass-Thru-Blades in slots NET1 and NET2 provide connections to channels A and B of the onboard LAN controllers of the server blades. The following figure shows the port assignment in a configuration with ten 2-way server blades.

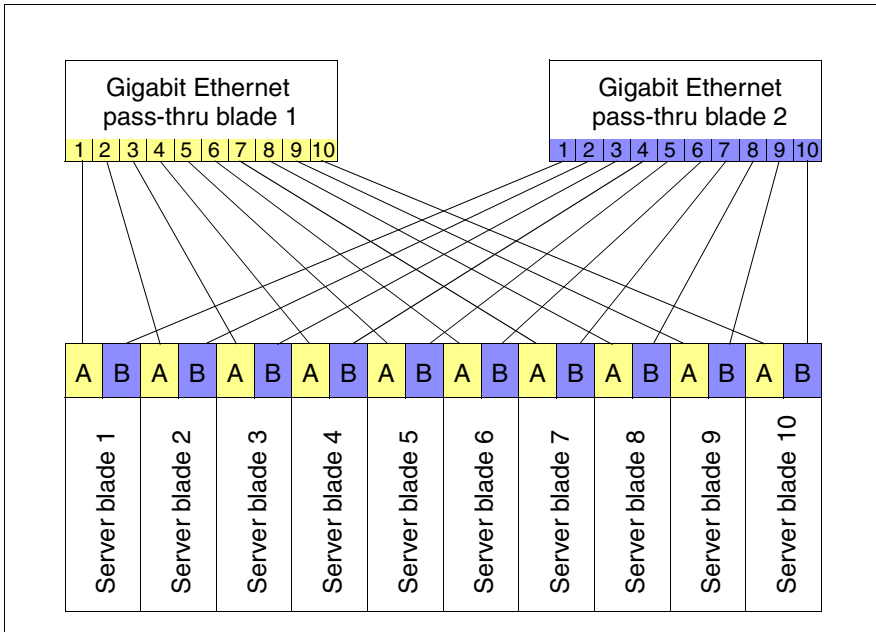

Figure 55: Ethernet port assignment with ten 2-way server blades

The Ethernet LAN Pass-Thru-Blades in slots NET3 and NET4 provide connections to channels A and B of the optional Gigabit Ethernet I/O modules. The ports in a configuration with ten 2-way server blades are assigned according to the same formula.

Configuration with Five 4-way Server Blades

A PRIMERGY BX6xx 4-way server blade offers two onboard LAN controllers with two LAN channels each, and two slots for optional Gigabit Ethernet I/O modules, also with two LAN channels each.

The Ethernet LAN Pass-Thru-Blades in slots NET1 and NET2 provide connections to channels A and B of the onboard LAN controllers of the server blades. The following figure shows the port assignment in a configuration with five 4-way server blades.

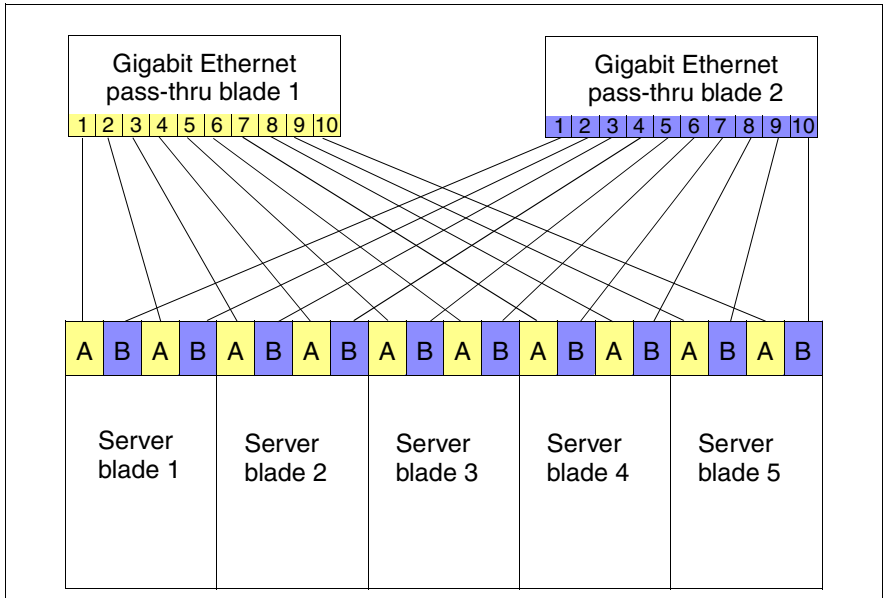

Figure 56: Port assignment to the onboard LAN controllers with five 4-way server blades

The following figure illustrates the assignment of the LAN ports of the Ethernet LAN Pass-Thru-Blades in slots NET3 and NET4 to the channels of the Gigabit Ethernet I/O modules (daughter cards) of the server blades in a configuration with five 4-way server blades.

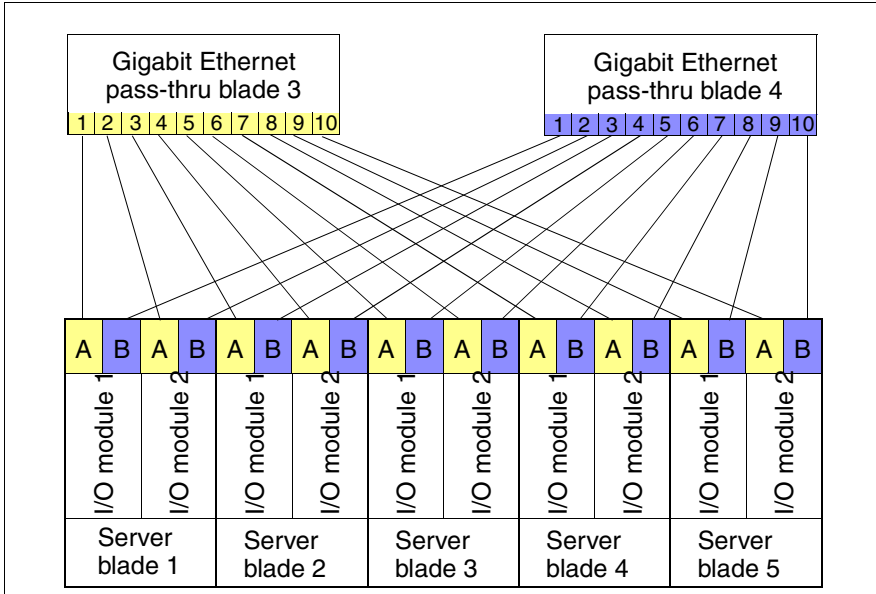

Figure 57: Port assignment to the Gigabit Ethernet I/O modules with five 4-way server blades

9.3 Replacing an Ethernet Pass-Thru Blade



CAUTION!

- Ethernet pass-thru-blades must always be installed in slots NET1 and NET3 first (see [page 101](#)).

An Ethernet LAN Pass-Thru-Blade is installed and removed in the same way as a LAN switch blade (see [section “Installing a LAN Switch Blade” on page 93](#)).

10 Fibre Channel Switch Blade

The 2/4 Gbit Brocade SilkWorm 4016 Fibre Channel switch blade, hereinafter referred to as FC switch blade, provides up to ten internal fabric ports to the server blades and up to six external fabric ports for fast and reliable connection to a SAN. The FC switch blade automatically adapts to transfer rates of 1 up to 4 Gbit/s. With the BX600 S2 basic unit it offers transfer rates of 2 Gbit/s (internal) and 4 Gbit/s (external). A 10/100 Mbit/s RJ45 connection is available for administration of the FC switch blade across a LAN.

i All features of *Brocade Fabric OS 5.0.4*, the joint software platform for Brocade fibre channel switches, are available as an operating system for the FC switch blade. Administration of the FC switch blade is handled by *Fabric Watch* and *Advanced Web Tools* from Brocade.



Figure 58: Fibre Channel Switch Blade

i Besides the 16-ports version the switch blade unit is available as a 12-ports version with eight internal and four external fabric ports.

The PRIMERGY BX600 S2 base unit can be fitted with two FC switch blades. The slots for the FC switch blades are on the rear of the base unit (NET3 and NET4 in [figure 60 on page 108](#)). Section “[Port Assignment](#)” on [page 108](#) describes how the fibre channel ports of the server blades are assigned to the FC switch blades.

10.1 Control and Connection Panel

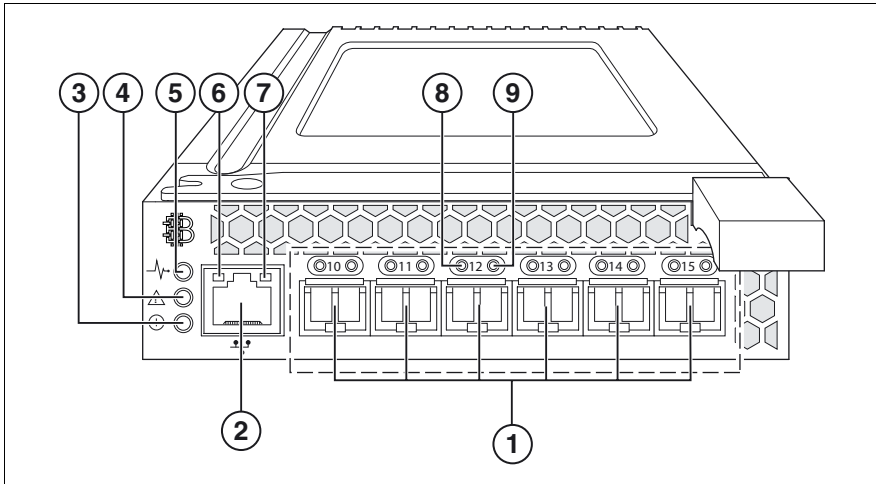



Figure 59: Control and Connection Panel of the FC switch blade

1	<p>External FC connection (6x) socket for LWL or SWL FC SFP module (see section “Fibre Channel SFP module” on page 115).</p>
2	<p>RJ45 LAN connection with two integrated status LEDs (see items 6 and 7)</p>
3	<p>FC switch blade voltage status display (green LED) lights up when the base unit is switched on (12 V input voltage present).</p>
4	<p>FC switch blade status display (2-color LED)</p> <p>Dark: FC switch blade is not operating</p> <p>Lights green: FC switch blade is operating</p> <p>Lights amber: Boot phase; one or more ports are off-line</p> <p>Blinks amber/green: Warning: a fault has occurred.</p> <p> The LED might also blink while testing.</p>
5	<p>Management blade display (2-color LED) Lights up when the FC switch blade is being controlled directly via the management blade user interface.</p>

6	<p>LAN speed display (green LED)</p> <p>Dark: LAN transfer rate 10 Mbit/s</p> <p>Lights green: LAN transfer rate 100 Mbit/s</p>
7	<p>LAN activity indicator of the FC switch blade (amber LED)</p> <p>Dark: No connection</p> <p>Lights: LAN connection is available</p> <p>Blinks: Data transport</p>
8	<p>Status display of ext. FC ports (2-color LED)</p> <p>Dark: No signal reception</p> <p>Flickers green: FC port on-line, data transport</p> <p>Blinks green: <ul style="list-style-type: none"> – slow: FC port on-line, but segmented. – fast: internal loop </p> <p>Lights amber: Signal reception, but not on-line</p> <p>Blinks amber: <ul style="list-style-type: none"> slow (~ 2 sec. intervals): FC port disabled. fast (~ 0.5 sec. interval): FC port faulty </p>
9	<p>Speed display of ext. FC port (2-color LED)</p> <p>Dark: FC transfer rate 1Gbit/s</p> <p>Lights green: FC transfer rate 2Gbit/s</p> <p>Lights amber: FC transfer rate 4Gbit/s</p>

10.2 Port Assignment

Connections to the two fabric ports of the optional fibre channel daughter card are provided for each of the ten server blade slots. In the case of 4-way server blades, connections for a total of four fabric ports are therefore available.

The FC switch blade in the NET3 slot is connected to port A of the installed fibre channel daughter cards. The FC switch blade in the NET4 slot is connected to port B of the installed fibre channel daughter cards.

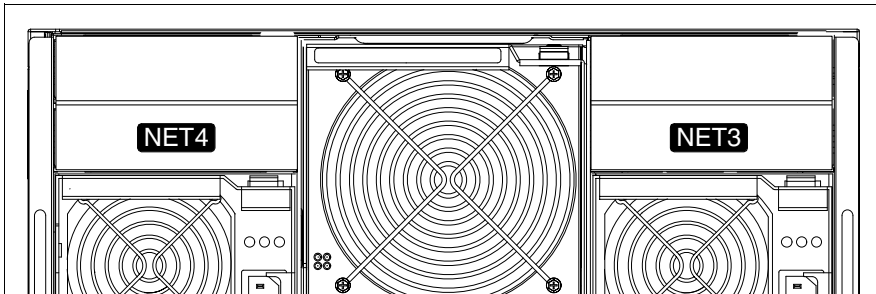

Figure 60: Slots for FC switch blades

The installation of two FC switch blades enables redundant fibre channel connections to be provided for the server blades.



CAUTION

- FC switch blades must always be installed in slot NET3 first. This ensures that port A of the FC daughter cards is connected if redundant fibre channel connections are not used.
- If Gigabit Ethernet daughter cards are installed in the server blades, LAN switch blades (see [page 81](#)) or Ethernet pass-thru blades (see [page 99](#)) must be installed in slots NET3 and NET4.

Simultaneous operation of Ethernet blades and fibre channel blades in slots NET3 and NET4 is not permitted.

The configuration examples below show the assignment of the FC daughter card ports to the LAN switch blades in slots NET3 and NET4.

Configuration with ten 2-way server blades

The illustration below shows the assignment of FC switch blades to the fabric ports of the server blades in a configuration with ten 2-way server blades.

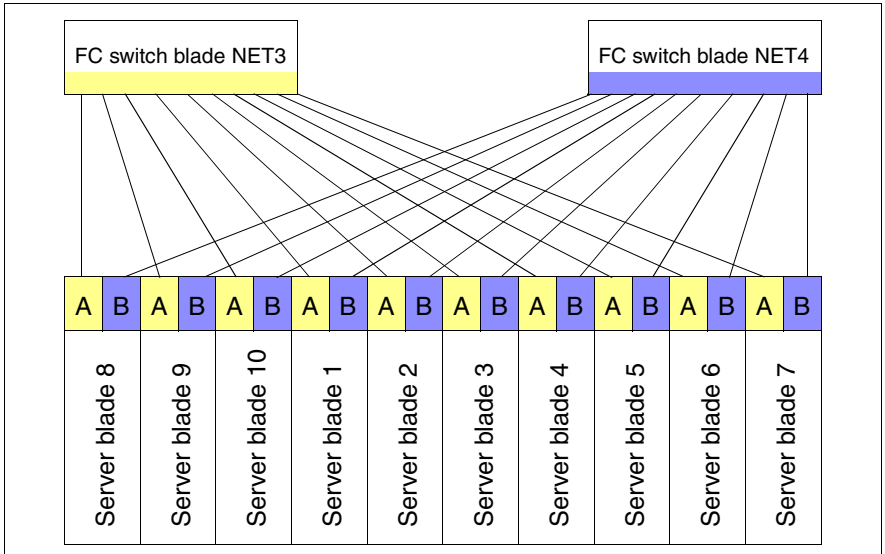

Figure 61: Fabric port assignment with 2-way server blades

i When using the 12-port version the fabric ports of the server blades 6 and 7 (slots 9 and 10) are not available.

Configuration with five 4-way server blades

The illustration below shows the assignment of FC switch blades to the fabric ports of the server blades in a configuration with five 4-way server blades.

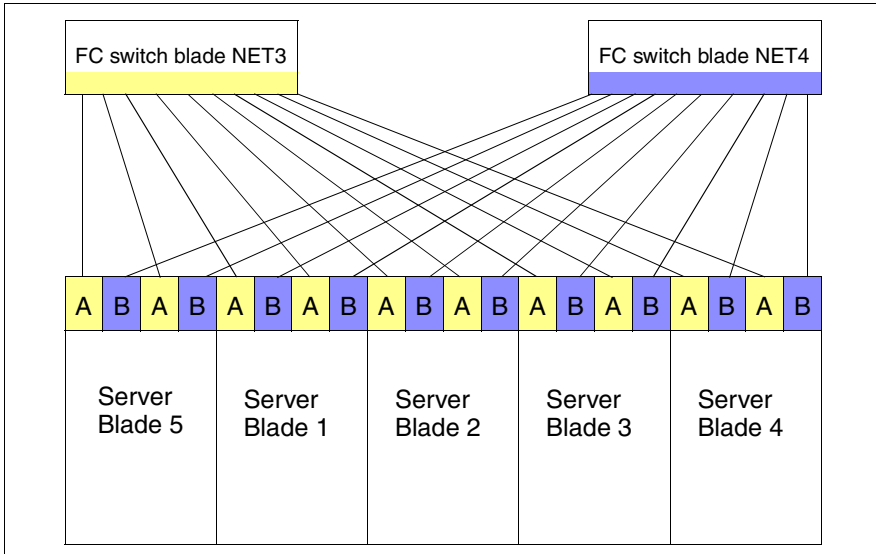

Figure 62: Fabric port assignment with five 4-way server blades

i When using the 12-port version the fabric ports of server blade 4 (slots 9 and 10) are not available.

Configuration with a combination of 2-way server blades and 4-way server blades

The illustration below shows the assignment of FC switch blades to the fabric ports of the server blades in a configuration with two 4-way server blades and six 2-way server blades.

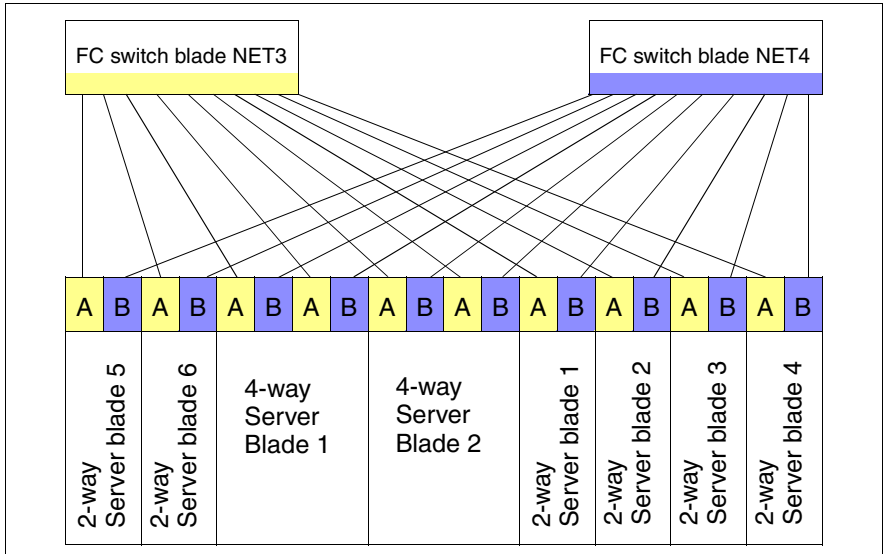

Figure 63: Fabric port assignment with 4-way and 2-way server blades

i When using the 12-port version the fabric ports of the 2-way server blades 3 and 4 (slots 9 and 10) are not available.

10.3 FC switch blade installation

CAUTION

- FC switch blades must always be installed in slot NET3 first (see [page 108](#)).

The installation and removal of FC switch blades takes place in the same way as the installation of fibre channel pass-thru blades (see [page 121](#)).

11 Fibre Channel Pass-Thru Blade

The 2/2 Gbit Fibre Channel pass-thru blade, hereinafter referred to as FC pass-thru blade, provides 10 ports for the bypass connection between FC daughter boards (see manual for the relevant server blade type) and optical transceivers for serial FC I/O and general-purpose I/O signals. The FC pass-thru blade features 2 Gbit/sec Fibre Channel speed. It also provides LEDs for each FC port to indicate the link status.

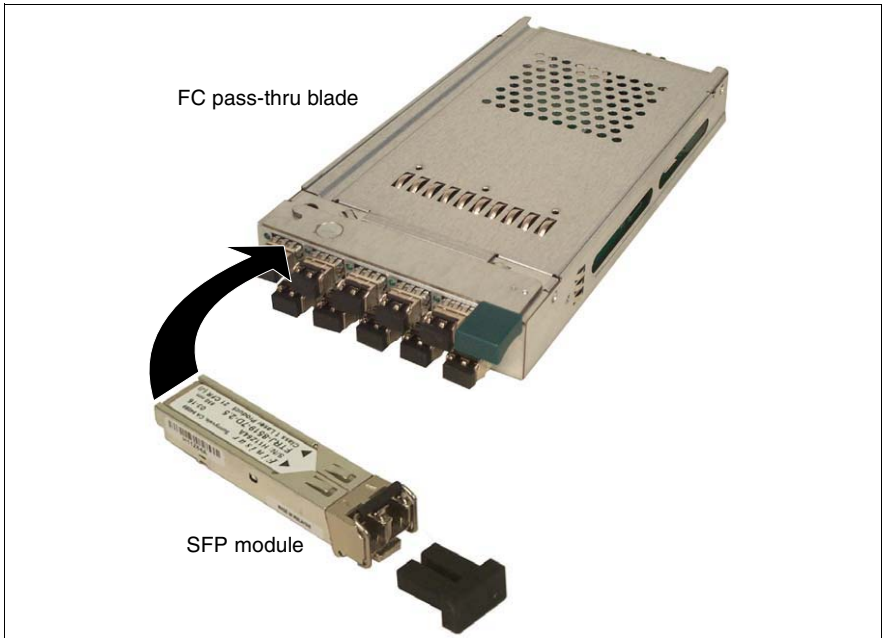

Figure 64: Fibre Channel pass-thru blade

The PRIMERGY BX600 S2 basic unit can be fitted with one or two FC pass-thru blades. The slots for these blades are on the back of the system unit (NET 3 and NET4 in [figure 69 on page 117](#)). If Fibre Channel functionality is to be available for one or more server blades, at least one FC pass-thru blade or FC switch blade must be installed. The assignment of the Fibre Channel channels is described in [section “Port Assignment of the FC Pass-Thru Blades” on page 117](#).

11.1 Control and Connection Panel

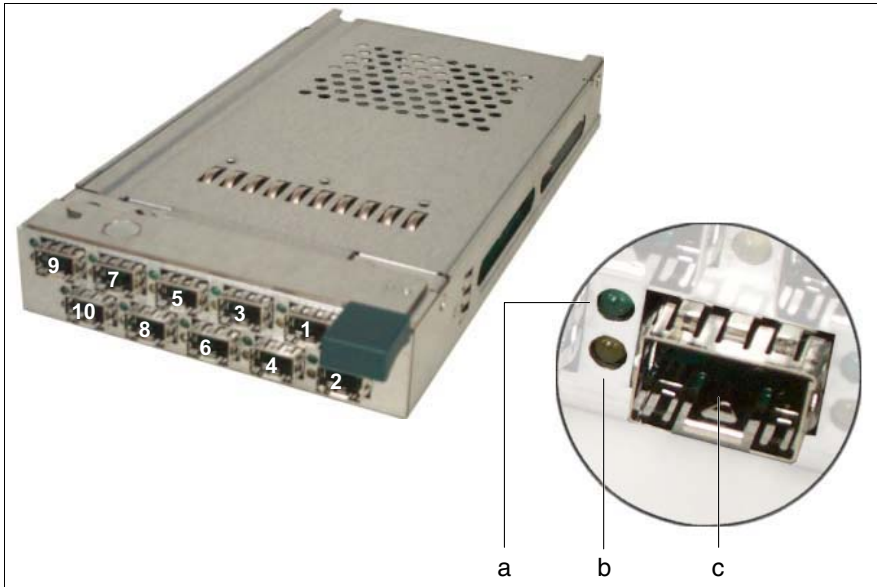

Figure 65: FC pass-thru blade control connection panel

The following indicator and connection elements are provided:

a	Fibre Channel active indicator (green LED)
b	Fibre Channel link indicator (amber LED)
c	Fibre Channel SFP connector Slot for Fibre Channel SFP module (see page 115). The slot numbers are assigned to the server blade slots on the front of the BX600 S2 system (see figure 29 on page 72).

The following table shows the conditions of the Fibre Channel ports indicated by the LEDs.

Fibre Channel condition	a	b
Power ON	ON	ON
Fibre Channel is online	ON	OFF
Signal acquired	OFF	ON
Loss off synchronization	ON	Blinks

11.2 Fibre Channel SFP module

A Fibre Channel SFP module is required to connect an FC pass-thru blade port to a Fibre Channel cable. If no cable is plugged in, the SFP module slots must be fitted with a safety plug as shown in the figure below.

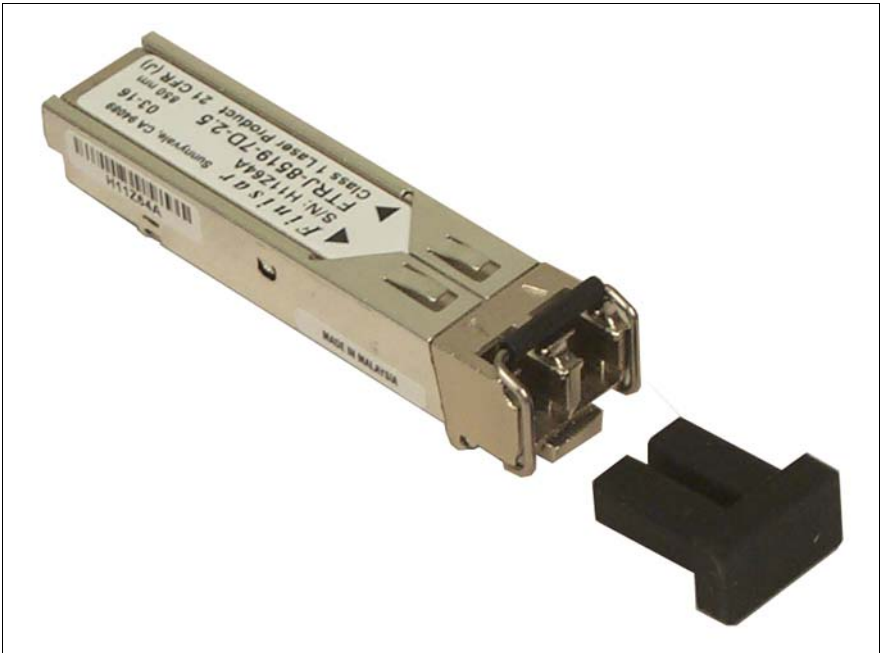

Figure 66: Fibre Channel SFP connector

Inserting a Fibre Channel SFP module

For each server blade connected via Fibre Channel, SFP modules must be plugged into the appropriate FC pass-thru blade slots. For information on the port assignment see [section “Installation Sequence” on page 73](#).

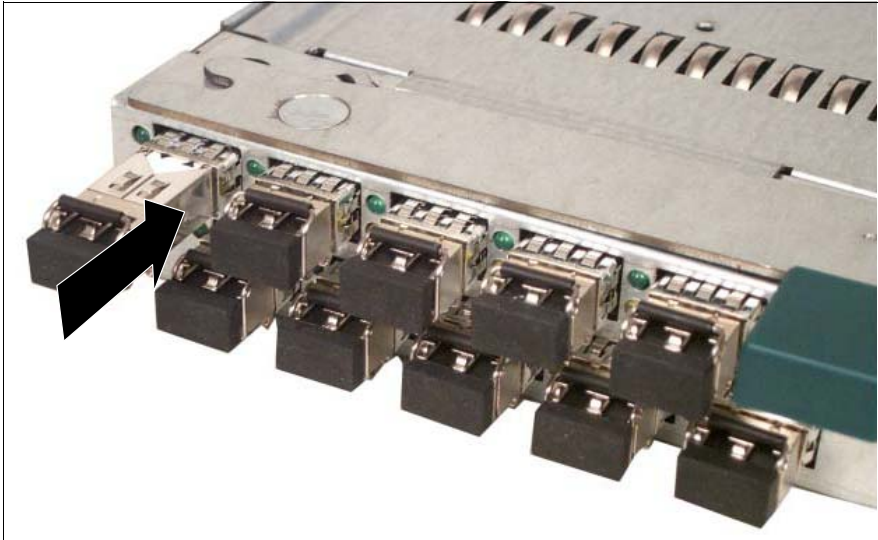

Figure 67: Inserting an SFP module

- ▶ Push the SFP with the label facing upward into the slot assigned to the server blade to be connected.

Removing an SFP Module

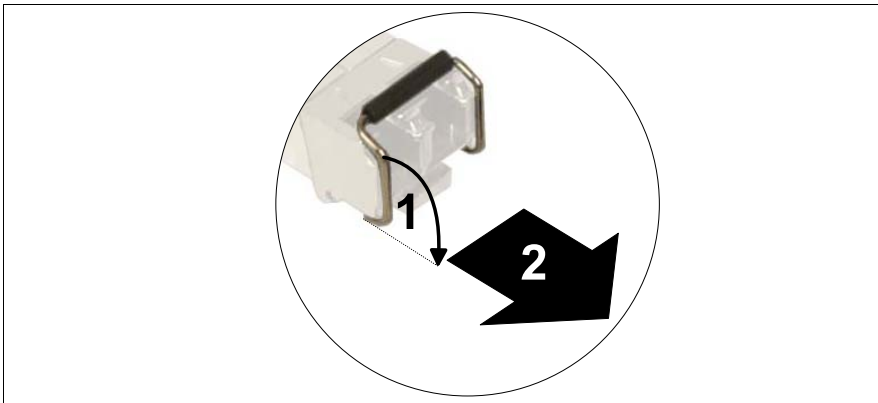

Figure 68: Removing an SFP module

- ▶ Swivel the locking clip in the direction of the arrow (1) to disengage the locking mechanism of the SFP module and pull it out of the slot (2).

11.3 Port Assignment of the FC Pass-Thru Blades

FC pass-thru blades can be installed in slots NET3 and NET4 on the rear of the base unit. The FC pass-thru blade in slot 1 provides a bypass connection between channel A of the installed fibre channel daughter cards and the corresponding optical transceivers. The FC pass-thru blade in slot 2 provides a connection to channel B of the installed fibre channel daughter cards.

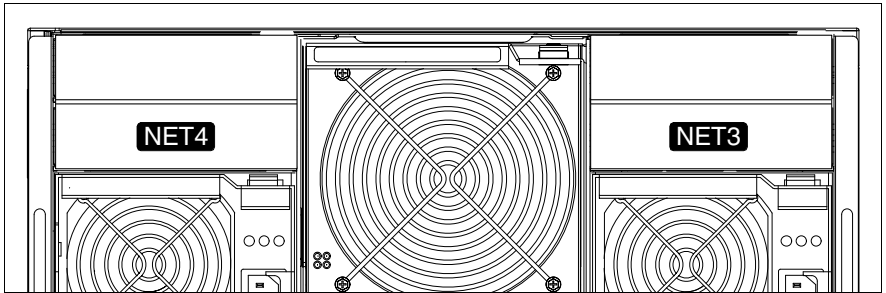

Figure 69: Slot numbering for the Fibre Channel pass-thru blades



CAUTION

- FC pass-thru blades must always be installed in slot NET3 first. This ensures that port A of the FC daughter cards is connected if redundant fibre channel connections are not used.
- If Gigabit Ethernet daughter cards are installed in the server blades, LAN switch blades (see [page 81](#)) or Ethernet pass-thru blades (see [page 99](#)) must be installed in slots NET3 and NET4.

Asynchronous balanced mode of Ethernet blades and fibre channel blades in slots NET3 and NET4 is not permitted.

Each FC pass-thru blade has ten front slots for SFP modules, via which the Fibre Channel connections to the server blades are established. The SFP modules are assigned to the server blades according to the numbering of the slots (see [figure 70](#) and [figure 71](#)).

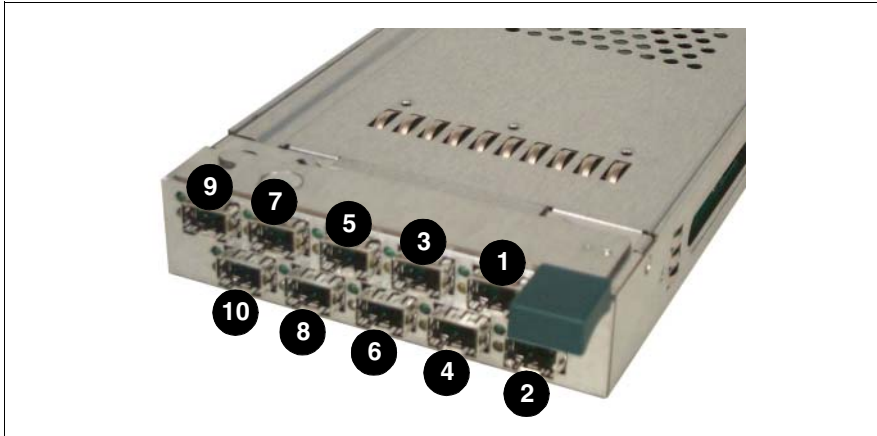

Figure 70: Slot numbering for the SFP modules

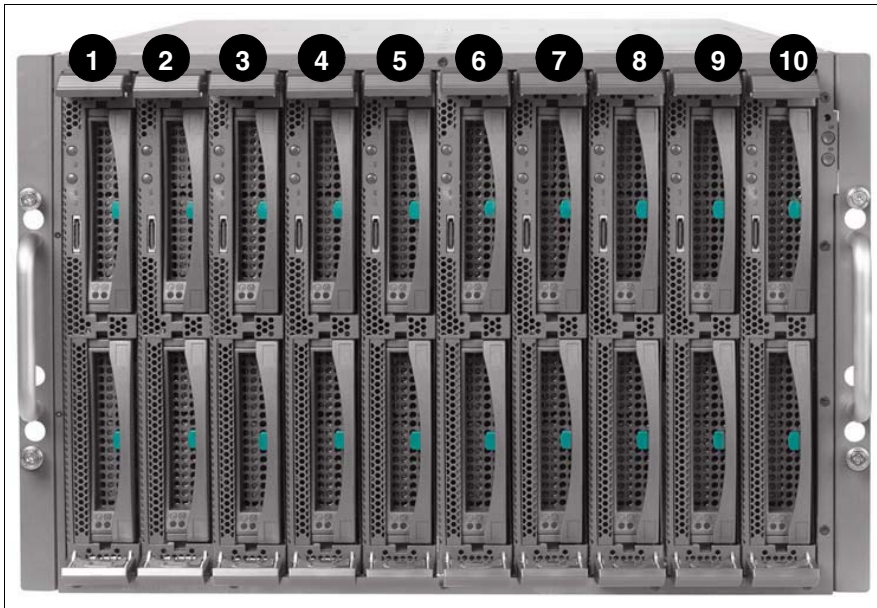

Figure 71: Slot numbering for the server blades

In the following the assignment of the Fibre Channel ports is shown using configuration examples.

Configuration with Ten 2-way Server Blades

The following figure illustrates the assignment of the Fibre Channel ports of the FC pass-thru blades and the server blades in a configuration with ten 2-way server blades when two FC pass-thru blades and, in each server blade, an FC daughter board are installed.

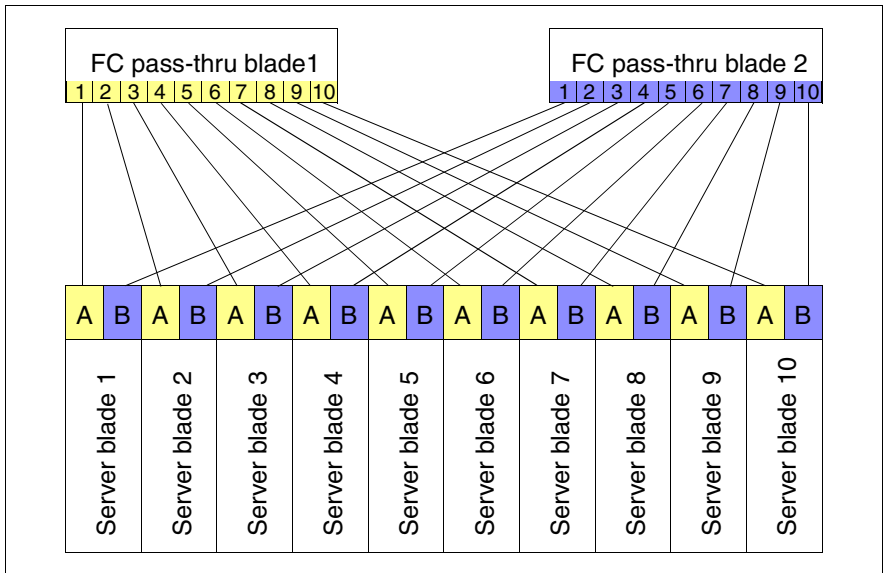

Figure 72: Fibre Channel port assignment with ten 2-way server blades

Configuration with Five 4-way Server Blades

Because a 4-way server blade occupies two slots in the blade server chassis, there are four connections for four Fibre Channel ports available for a 4-way server blade. To use these connections, two FC daughter boards must be installed on the 4-way server blade (see manual for the relevant server blade type).

The following figure illustrates the assignment of the FC pass-thru blades to the Fibre Channel ports of the server blades in a configuration with five 4-way server blades when two FC pass-thru blades and, in each 4-way server blade, two FC daughter boards are installed in the back of the server.

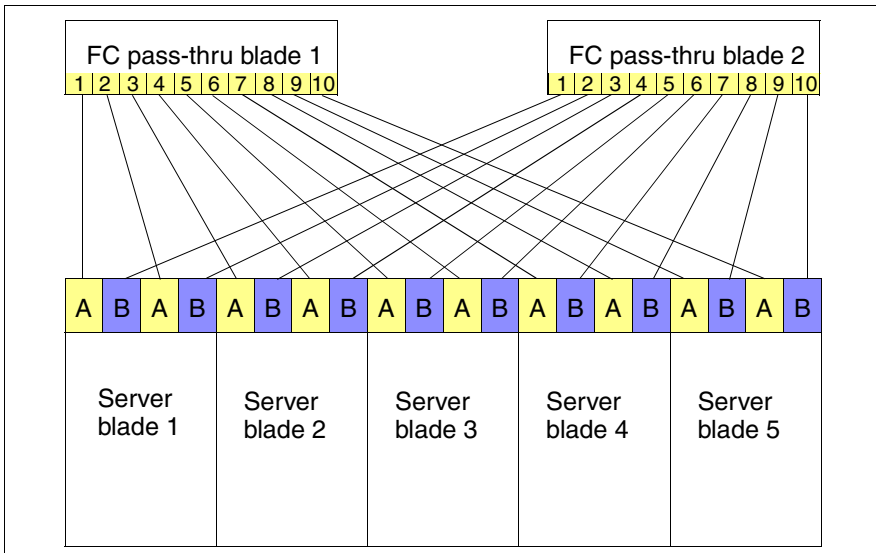

Figure 73: Fibre Channel port assignment with five 4-way server blades

11.4 Exchanging an FC Pass-Thru Blade



CAUTION!

- Read the safety information and the information on handling electrostatic-sensitive components in the [section “Components With Electrostatic-Sensitive Devices” on page 25](#).
- The FC pass-thru blade must always be installed in slots and NET3 first (see [page 117](#)).

Removing the FC pass-thru blade

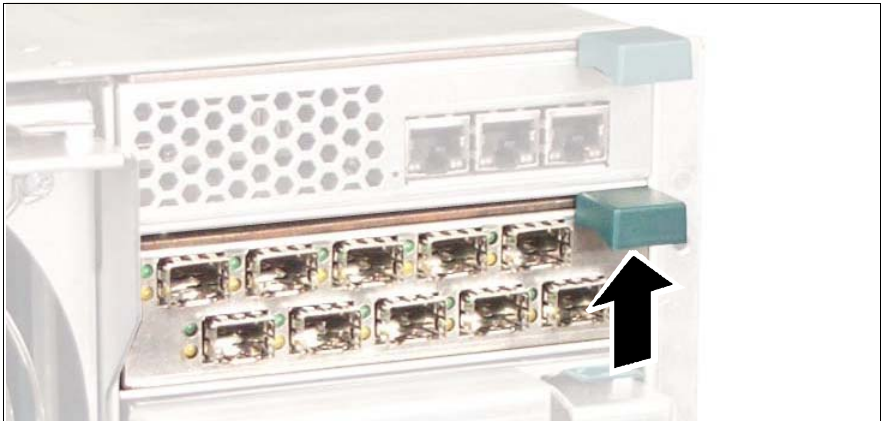

Figure 74: Disengaging the FC pass-thru blade

- ▶ Press the spring on the underside of the eject handle to unlock it.

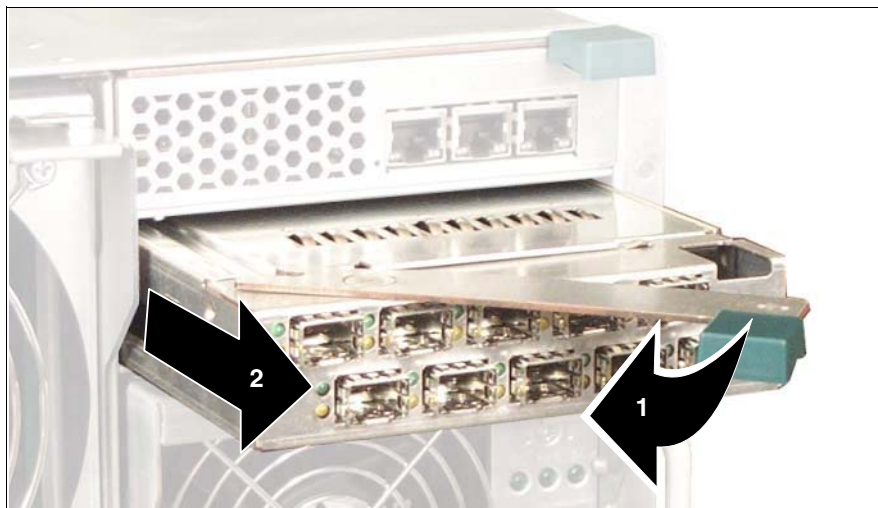

Figure 75: Disengaging the FC pass-thru blade

- ▶ Swing the eject handle (1) of the FC pass-thru blade in the direction of the arrow until the locking mechanism disengages and the blade is ejected a few centimeters.
- ▶ Remove the FC pass-thru blade from the slot (2).

The FC pass-thru blade is inserted using these instructions in reverse order.

**CAUTION!**

If you remove the FC pass-thru blade and do not replace it with a new one, you must insert a dummy module into the empty slot to ensure cooling, to comply with the applicable EMC regulations (regulations on electromagnetic compatibility) and for fire protection.

Make sure that the dummy module engages in the slot correctly.



Figure 76: FC pass-thru blade dummy module

12 Management Blade

The PRIMERGY BX600 S2 basic unit accommodates two hot-swappable, redundant management blades with an integrated management solution for complete remote administration of the system.

i The management blades provide convenient user interfaces: A web interface is available as well as a console menu interface using the Telnet protocol. For a detailed description please see the manual “RemoteView Management Blade - User Interface Description”.

The management blades have separate, 10 Mbit LAN connections to maintain accessibility to the system even with the standard traffic network connections down.

The slots for the management blades are located on the rear of the basic unit ([figure 77](#)).

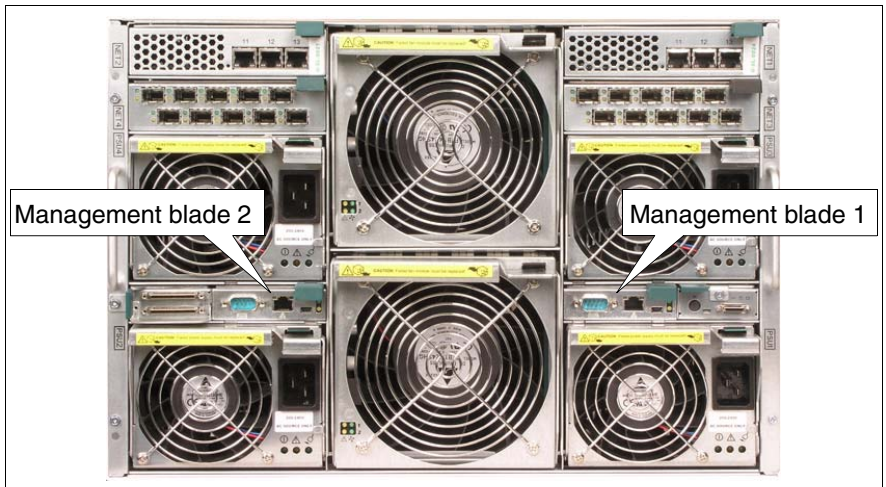

Figure 77: Management blade slots

i *Important note:*
Management blades to be used in the PRIMERGY BX600 S2 base unit must have order number A3C40073243. Compatibility with the S1 model management blade used in the PRIMERGY BX600 base unit is not provided.

12.1 Control and Connection Panel

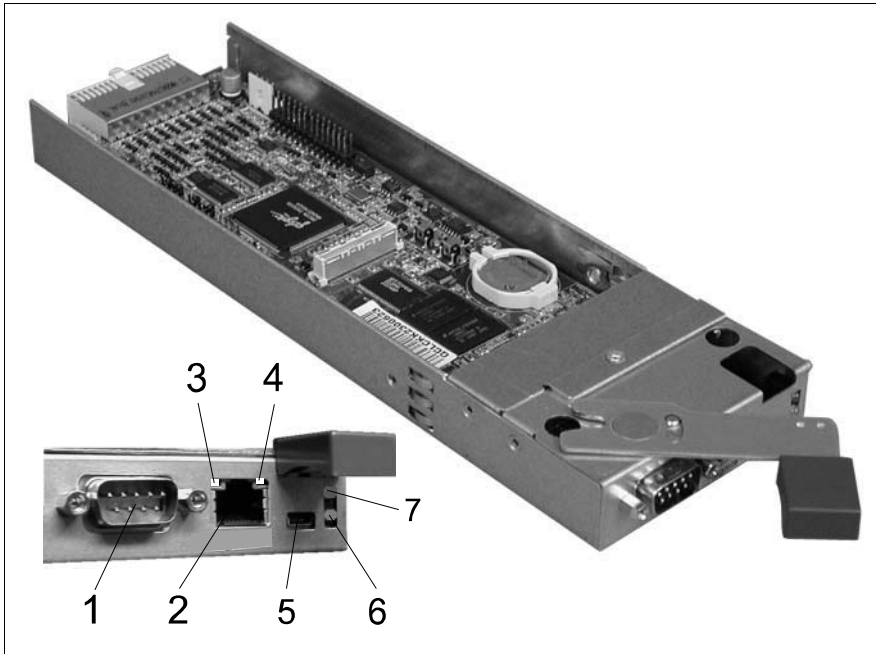

Figure 78: Management blade control and connection panel

The following indicator and connection elements are provided:

1	<p>Serial port connector</p> <p>Standard serial port, management communication port.</p>
2	<p>LAN connector (with two integrated LAN status LEDs (see next positions 3 and 4))</p> <p>LAN port, RJ45, 10Mb management LAN.</p>
3	<p>LAN link indicator (green LED)</p> <p>Lights green: The LAN is linked.</p> <p>Blinks green: Boot up power ready indicator.</p>

4	<p>LAN active indicator (amber LED)</p> <p>Lights amber: The LAN is active.</p> <p>Blinks amber: Boot up power ready indicator.</p>
5	<p>I2C connector</p> <p>Proprietary I2C (IPMI) connector for Fujitsu Siemens Computers service applications.</p>
6	<p>Failure indicator (amber LED)</p> <p>Dark: This management blade is OK (see table below).</p> <p>Lights amber: If only one management blade is present: this blade has failed (see table below).</p> <p>Blinks amber (2 sec.): Management blade is running in power up mode (generating heart beat for master/slave selection).</p>
7	<p>Master indicator (green LED)</p> <p>Unlit: This management blade is a slave (standby), backup of the master management blade (see table below).</p> <p>Lights green: This management blade is the master, responsible for the entire system management (see table below).</p> <p>Blinks green: This management blade is in special mode</p>

The following table shows the conditions of the management blades indicated by the interaction of master indicator and failure indicator LEDs.

Management blade condition	Master indicator (green LED)	Failure indicator (amber LED)
One management blade is installed and alive	ON	OFF
Two management blades are installed	ON (Master) OFF (Slave)	OFF
One management blade is installed and hangs up	ON	ON
Two management blades are installed and both hang up	ON	ON

12.2 Exchanging the Battery

In order to save the system information permanently, a lithium battery is installed to provide the CMOS memory with a current. When the charge is too low or the battery is empty, a corresponding error message is provided. The lithium battery must then be replaced.



CAUTION!

Read the safety information and the information on handling batteries in the section [“Batteries” on page 24](#).

Incorrect replacement of batteries may lead to a risk of explosion. The battery may only be replaced with an identical battery or with a type recommended by the manufacturer.

Make sure you insert the battery the right way round. The plus pole must be at the top!

The following figure shows the position of the battery (1) on the management blade board.

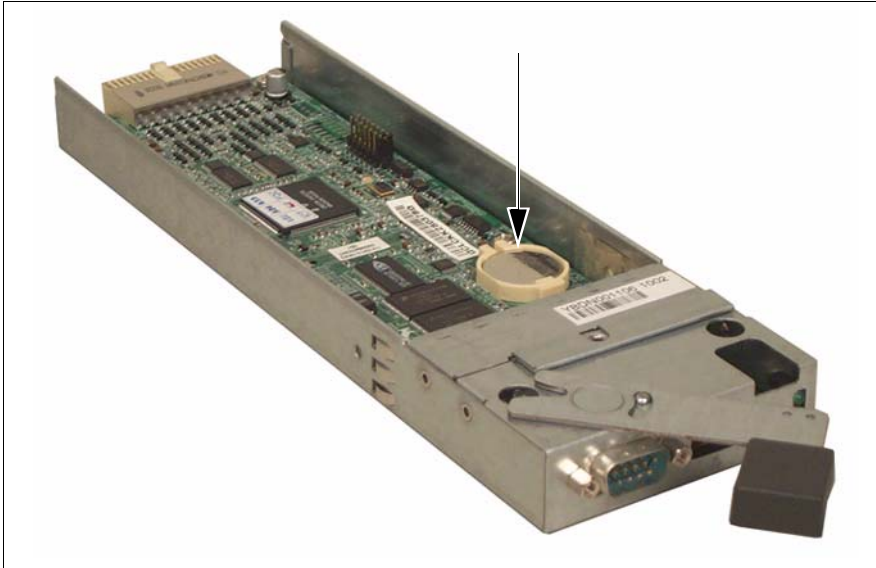

Figure 79: Position of the management blade battery (arrow)

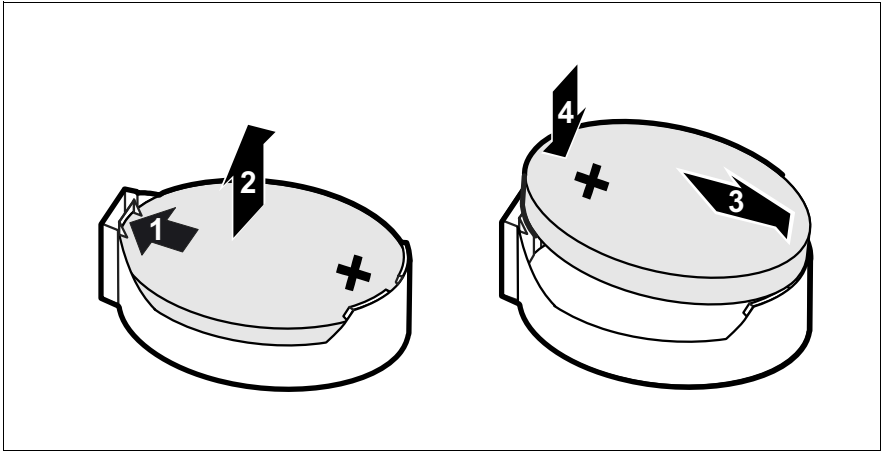

Figure 80: Inserting/removing the management blade battery

- ▶ Push the holding spring in the direction of the arrow (1) so that the lithium battery pops out of its holder, and remove the battery (2).
- ▶ Place the new battery of the same type in the holder (3) and push it in the direction of the arrow (4) until it slots into place.

12.3 Exchanging a Management Blade



CAUTION!

Read the safety information and the information on handling electrostatic-sensitive components in the [section “Components With Electrostatic-Sensitive Devices”](#) on page 25.

Removing the Management Blade



Figure 81: Disengaging the management blade

- ▶ Press the spring on the underside of the eject handle to unlock it.



Figure 82: Disengaging the management blade

- ▶ Swing the eject handle of the management blade in the direction of the arrow until the locking mechanism disengages and the blade is ejected a few centimeters.



Figure 83: Removing the management blade

- ▶ Remove the management blade from the slot.



CAUTION!

Both management blades must always be plugged in to ensure cooling, to comply with the applicable EMC regulations (regulations on electromagnetic compatibility) and for fire protection.

The management blade is inserted by following these instructions in reverse order.

13 KVM Blade

For administering the server blades, the PRIMERGY BX600 S2 basic unit offers a KVM blade, which allows the individual server blades to be connected to a console.



Figure 84: Position of the KVM blade

The following models are available:

- KVM blade (standard version)
- Adv. KVM blade
- Digital KVM blade

13.1 KVM Blade (Standard Version)

The standard KVM blade allows a monitor, PS2 keyboard and PS2 mouse to be connected for local administration of the server blades. This requires a special cable (see [figure 10 on page 43](#)). The server blade is assigned to the KVM blade by pressing the KVM button on the control panel of the server blade to be administered.

Control Panel of the KVM Blade (Standard Version)

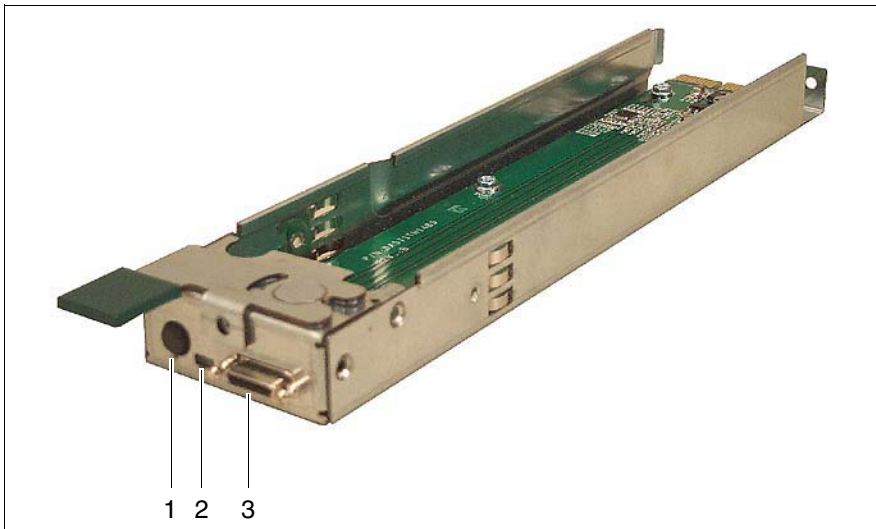

Figure 85: KVM blade

1	<p>Rear ID button</p> <p>When you press the ID button, the ID LEDs on the control panel on the front of the server blade and on the KVM blade are switched on or off. The ID LEDs on the KVM blade and on the control panel of the blade server are synchronized.</p>
2	<p>ID/error LED (green LED)</p> <p>Glows green: The ID button on the KVM blade or the ID button on the control panel at the front of the blade server was pressed to identify the system.</p> <p>Pressing one of the two ID buttons again deactivates the ID LED.</p> <p>Blinks green: Checksum error: System error.</p>
3	<p>KVM connector</p> <p>Allows a VGA monitor, PS2 keyboard and PS2 mouse to be connected via a special cable (see figure 10 on page 43).</p>

13.2 Adv. KVM Blade

The adv. KVM blade offers the same functionality as the standard version of the KVM blade plus a LAN port for connecting a Web-based console with the following features:

- Console emulation in graphics mode
- Makes the CD-ROM drive of the client PC available as a virtual USB 1.1/2.0 CD-ROM drive with boot option.
- Makes the floppy disk drive of the client PC available as a virtual USB 1.1/2.0 floppy disk drive with boot option.
- Software-controlled server blade selection
- Password-protected user authentication

The IP address of the adv. KVM blade is configured and the Web-based console (*Global View*) is invoked via the Web interface of the management blade. For more information on the adv. KVM blade see the manual "[PRIMERGY BX Blade Server Systems: RemoteView Management Blade - User Interface Description](#)".

Control Panel of the Adv. KVM Blade

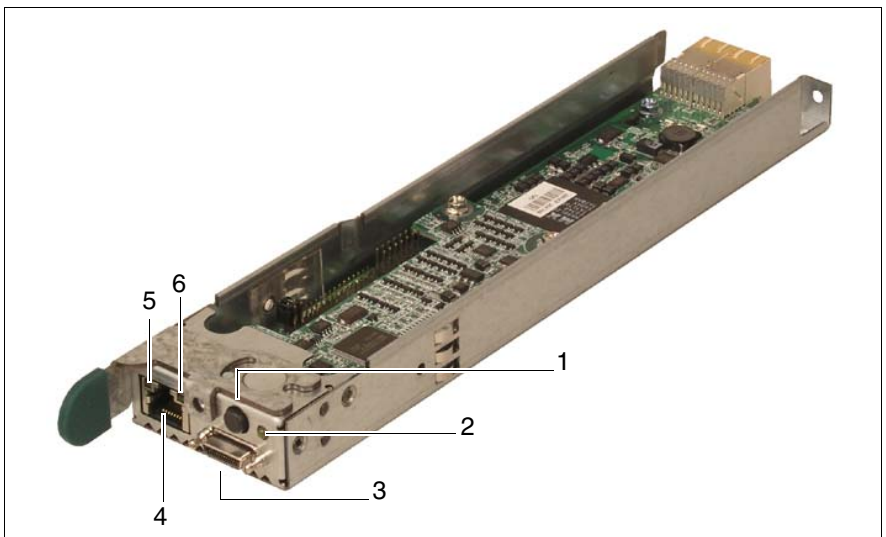

Figure 86: Adv. KVM blade

1	<p>Rear ID button</p> <p>If you press the ID button, the ID LED on the rear lights up. The front and the rear ID LEDs are synchronized.</p>
2	<p>Rear ID/error LED (green LED)</p> <p>Glows green: The system has been selected for identification by pressing the front or rear ID button (LED glows). Press one of the ID buttons to deactivate the ID LED.</p> <p>Blinks green: Checksum error: System error.</p>
3	<p>KVM connector</p> <p>Supports the connection of a VGA monitor, PS2 keyboard and PS2 mouse via a special cable (see figure 10 on page 43).</p>
4	<p>LAN connection (with two integrated LAN status LEDs (see the following items 5 and 6))</p> <p>LAN port, RJ45, 10/100 Mbit/s.</p>
5	<p>LAN activity indicator (green LED)</p> <p>Dark: LAN connection not active.</p> <p>Blinks green: Active LAN connection.</p>
6	<p>LAN connection indicator (orange LED)</p> <p>Dark: No connection.</p> <p>Glows: LAN connection available.</p>

13.3 Digital KVM Blade

The digital KVM blade offers the same functionality as the standard version of the KVM blade plus a LAN port for connecting a Web-based console with the following features:

- Console emulation in graphics mode
- Makes the CD-ROM drive of the client PC available as a virtual USB 1.1/2.0 CD-ROM drive with boot option.
- Makes the floppy disk drive of the client PC available as a virtual USB 1.1/2.0 floppy disk drive with boot option.
- Software-controlled server blade selection
- Password-protected user authentication

You can also connect cables from the BX600 digital KVM switch to a KVM appliance such as the Fujitsu Siemens s3-1621 Console Switch. This capability allows you to create large combinations of servers and switches that you can manage from a common access point or over your IP network.

The information necessary for configuring and operating the various switch blade models can be found in separate manuals, see [“Related Publications” on page 165](#)).

The IP address of the Digital KVM blade is configured and the Web-based console is invoked via the Web interface of the management blade. For more information on the digital KVM blade, see the separate manuals listed in [“Related Publications” on page 165](#)".

Control panel of the digital KVM blade

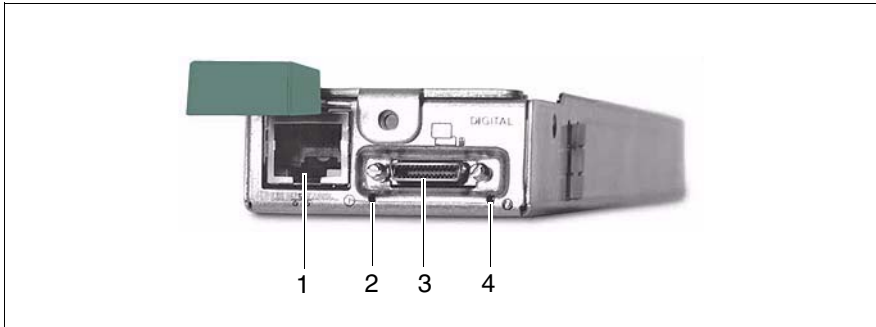

Figure 87: Digital KVM blade

<p>1</p>	<p>LAN connection LAN port, RJ45, 10/100 Mbit/s. LED A: LAN transfer rate indicator LED B: LAN link indicator</p>
<p>2</p>	<p>Power indicator Glows: Power enabled Blinks: Power disabled</p>
<p>2</p>	<p>KVM connection Offers support for VGA and PS2 keyboard and mouse via a special cable (see figure 10 on page 43) or for the connection to an external console switch.</p>
<p>4</p>	<p>ID indicator Glows: The system has been selected for identification by pressing the front or rear ID button.</p>
	<p>Blinks: System failure</p>

14 Power Supply Concept

In the basic configuration, the PRIMERGY BX600 S2 base unit contains two hot swap power supply units (PSU1 and PSU2 in [figure 88](#)). The power supply units adapt automatically to any voltage within the range 200 V - 240 V.

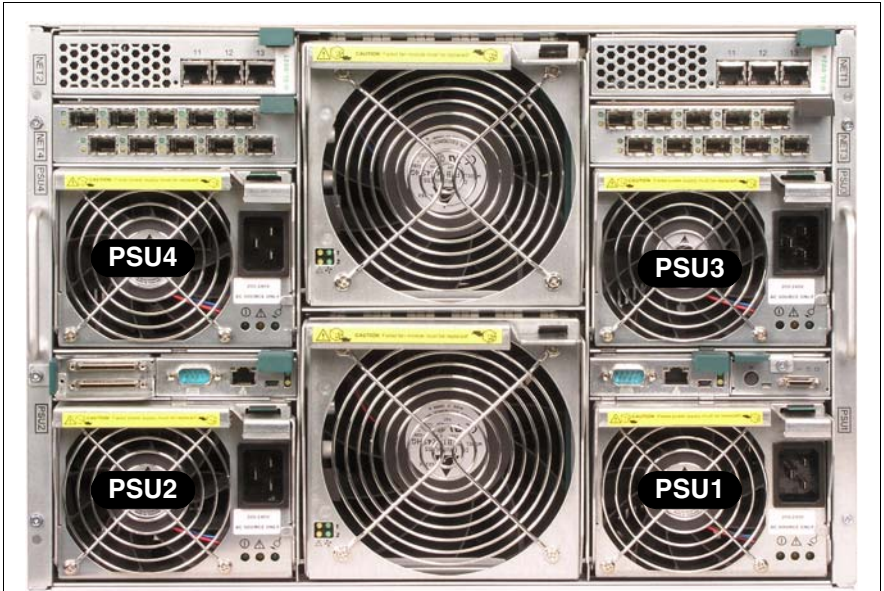

Figure 88: PRIMERGY BX600 S2 basic unit: power supply units

To provide a redundant power supply, a third or fourth power supply unit can be installed (PSU3 and PSU4 in [figure 88](#)).

If one of the four power units fails, the other two/three units will ensure the unit continues to operate normally. The defective power supply unit can be replaced while the unit is still running (hot swap).

i Please make sure that each of the power supply units is connected to a different phase. This will provide you with additional phase redundancy for high availability configurations. If one phase has failed, the power supply units connected to the other phases keep active. You can get full phase redundancy with up to three power supply units. With four power supply units, two of them are to be connected to one phase (see also [“Related Publications” on page 165](#)).

Phase redundancy is possible in regions, where a single phase provides 200 - 240V; in other regions with lower single phase voltage, two phases must be coupled and complete phase redundancy thus is not possible.

The unoccupied PSU slots are fitted with dummy modules to ensure that the electromagnetic emission properties of the system are observed and that the system components are properly cooled.

14.1 Power Supply Units

The power supply units (PSU) are directly accessible at the rear of the system ([figure 88 on page 139](#)):

The power supply unit can communicate with the system service processor via an internal management interface (IIC bus). The PSU part number, FRU data, barcode number, manufacturer ID, and fault data are stored in a VPD EEPROM module and can be recalled via the IIC bus. The PSU status can be displayed in the server management software *ServerView*.

Each power supply unit has a large fan on the front (A) and two smaller fans on the rear (B) that provide air cooling for the system (see [figure 89](#) below).

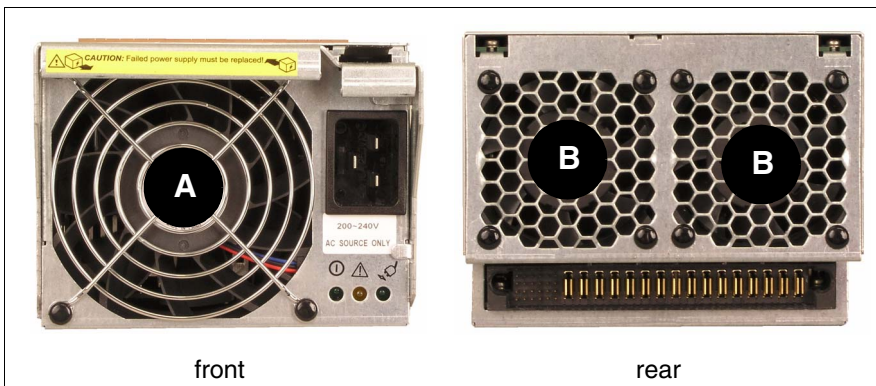

Figure 89: PSU: Fans

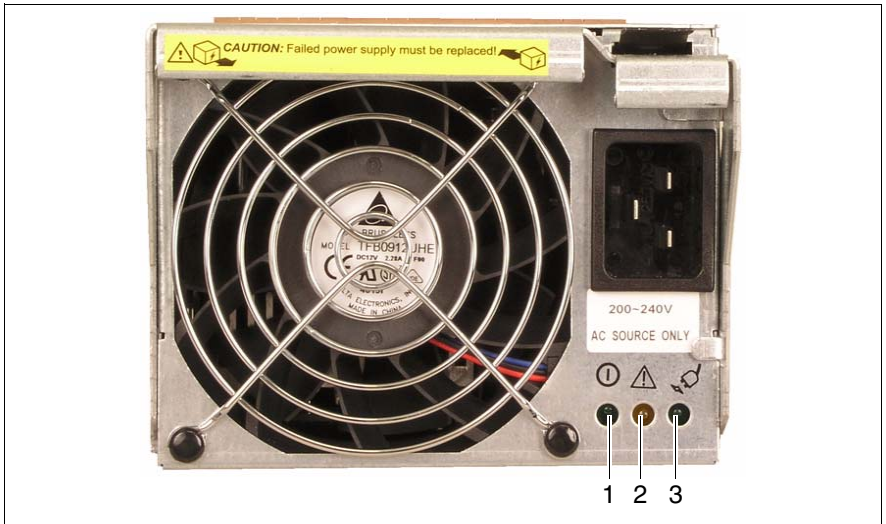





Figure 90: Power supply unit: LEDs

There are three LED displays on the front of the unit to allow the status of the power supply unit to be monitored.

<p>1</p> 	<p>On/off display (green LED) Lights up when the PRIMERGY BX600 S2 base unit is switched on.</p>
<p>2</p> 	<p>Fault display (amber LED) Lights up if a fault occurs on the power supply unit or if a fan¹ fails.</p>
<p>3</p> 	<p>Mains power supply display (green LED) Lights up when the mains connection is re-established.</p>

¹ If the large fan on the front fails, the power supply unit switches off. If one of the small fans on the rear fails, the power supply unit continues to run. See [figure 90](#) for the location of the power supply unit fans.

When the base unit is operating normally, LEDs 1 and 3 will be on all the time and LED 2 will be off. If LED 2 signals a fault by lighting up, the power supply unit affected must be replaced as soon as possible. This can be done while the base unit is still running (see [page 142](#)).

14.1.1 Replacing a Power Supply Unit

If a power unit fails, the front orange ID LED blinks in the system unit operator panel. The defective power unit can be replaced while the base unit is still running.



CAUTION

Do not, under any circumstances, remove a fan module if a power supply unit fails!

The 2100 W power supply unit is not downwardly compatible. It may only be used in the S2 variant of the PRIMERGY BX600 base unit.

If a system fault occurs and the front ID LED/fault LED blinks, the fault must be remedied before additional components can be removed or added.

To ensure continuous air circulation through the chassis, the slots for the power supply units must not be left empty and/or open for more than five minutes when the system is running. Components may be damaged if this five minute limit is exceeded.

- ▶ Check the FAN LED of the power supply units on the back of the system (see [figure 90 on page 141](#)) to determine which power supply unit is defective.
- ▶ **First disconnect** the power supply cable of the defective PSU from the mains.
- ▶ Remove the power supply cable from the insulated socket of the defective PSU.



CAUTION!

Be careful! The PSU can be **very hot!**



Figure 91: Disengaging the power supply unit (a = green touch point)

- ▶ Press the locking button (a) to disengage the locking mechanism of the PSU handle.



Figure 92: Removing the power supply unit

- ▶ Swivel the handle completely in the direction of the arrow to unlock the PSU from the chassis



Figure 93: Removing the PSU

- ▶ Pull the PSU out of the slot.



CAUTION!

Be careful! The PSU can be **very hot!**

To mount a PSU follow these instructions in reverse order.

14.1.2 Adding a Power Supply Unit

Depending on the desired configuration, the system can be upgraded with one or two additional power supply units.



CAUTION!

Read the safety information in the [chapter “Important Notes” on page 21](#).

**CAUTION!**

Because of chassis airflow disruption, the power supply unit slot should not be vacant and/or uncovered for more than five minutes when the system power is ON. Exceeding the five-minute limit may damage components.

All unoccupied PSU slots in the blade server system are fitted with PSU dummy modules ([figure 94](#)) to ensure that the electromagnetic emission properties of the system are observed and that the system components are properly cooled.

Each PSU dummy module includes three fans respectively.

There is one LED indicator (1 on [figure 94](#)) on the front of the PSU dummy module for monitoring the status of built-in fans.



Figure 94: PSU dummy module

If you want to install an additional power supply unit, you must first remove the PSU dummy module from the corresponding slot.

- ▶ Remove the PSU dummy module from the corresponding slot.

Removal/installation is the same as for the power supply unit (see [section "Replacing a Power Supply Unit" on page 142](#)).

**CAUTION!**

Keep the dummy module for future use. If you remove a power supply unit and do not replace it with a new one, you must reinstall the dummy module.

- ▶ Insert the additional power supply unit in the corresponding slot and connect it to the mains.

15 Ventilation Concept

The basic unit is kept cool by two fan units (two fans each), and the fans in the power supply units (three fans in each PSU) and/or the fans in the PSU dummy unit(s) (two fans in each dummy).

The fan units are accessible from the rear of the system and contain two fans each.

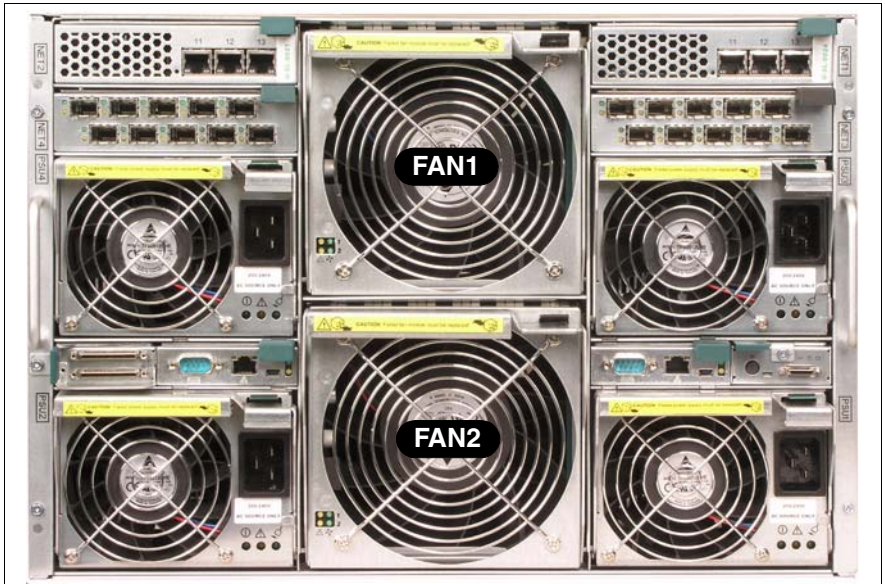

Figure 95: PRIMERGY BX600 S2 basic unit: fan units

When a fan in a fan or power supply unit/PSU dummy module fails, the amber front identify LED (see [figure 15 on page 50](#)) on the front panel blinks. You can find out which unit is defective by checking the fan status via the server management software *ServerView*.

i Even though the system can continue operating with a defective fan, the defective fan or power supply unit/PSU dummy module should be replaced as soon as possible.

For how to replace a power supply unit/PSU dummy module, see [section “Replacing a Power Supply Unit” on page 142](#).

Due to the hot-swap architecture, replacement is also possible during operation.

15.1 The Fan Unit

The fan unit includes two redundant fans.

There are four LED indicators (figure 96) on the front of the fan unit for fan status monitoring.

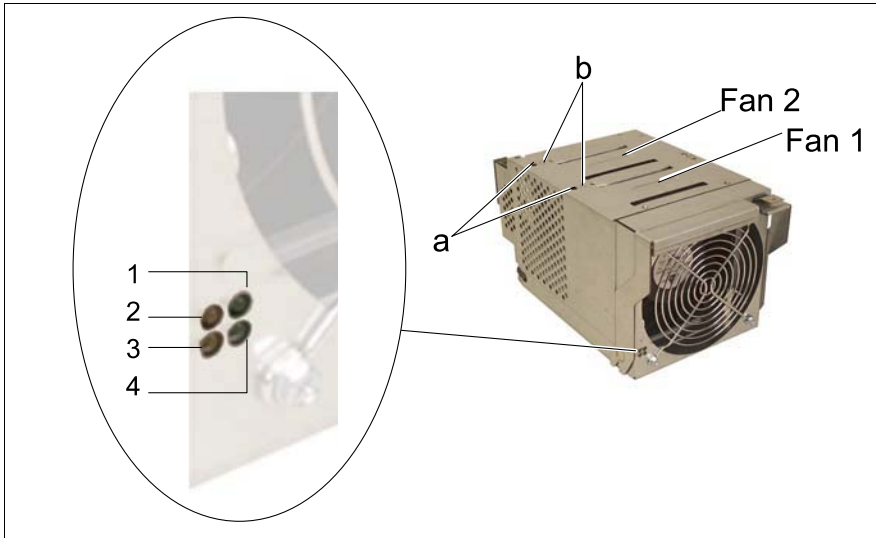

Figure 96: The fan unit

Fan condition	Fan 1 LEDs		Fan 2 LEDs	
	1 (green)	2 (amber)	4 (green)	3 (amber)
Present and OK	ON	OFF	ON	OFF
Not present	OFF	OFF	OFF	OFF
Present and failed	ON	ON	ON	ON

Table 2: Fan unit indicators

In addition, for each fan in the unit an error LED driven by backup capacitor is available. These two LEDs (a) are located on the top of the fan unit to indicate the respective defective fan. The LEDs can be activated via a pushbutton (b) after the fan unit has been removed from the chassis.

15.1.1 Replacing the Fan Unit

**CAUTION!**

If a system error has occurred and the front identify/fault LED is blinking, the error must be resolved before any additional components are added or removed.

Make sure that all necessary power supply units are inserted and functioning before you remove and/or install one of the fan units!

**CAUTION!**

The system can continue operating without one fan.

The defective fan must be replaced within a reasonable amount of time (max. 2 minutes).

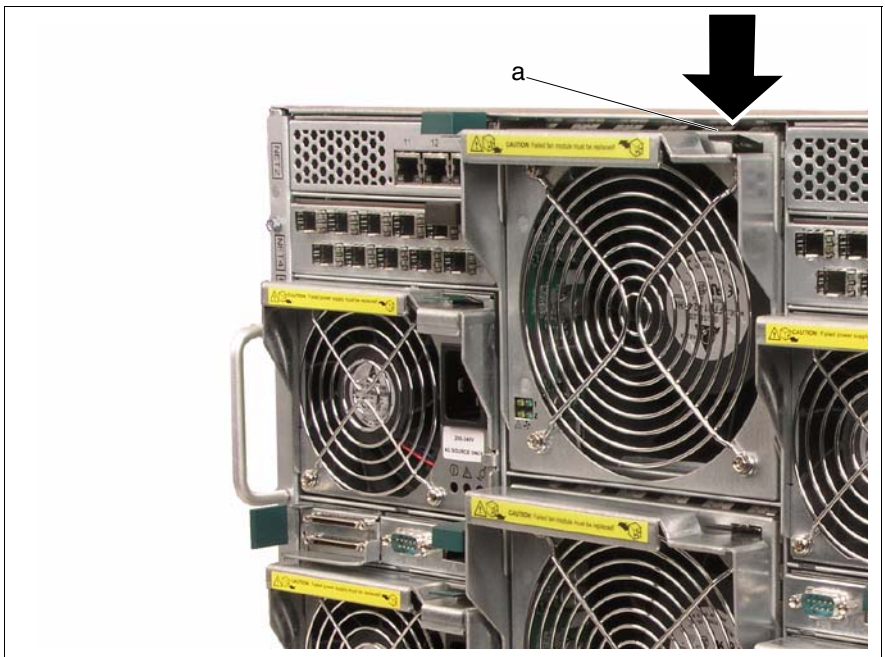

Figure 97: Disengaging the fan unit (a = green touch point)

- ▶ Press the locking button (green) to disengage the locking mechanism of the unit handle.



Figure 98: Removing the fan unit

- ▶ Swivel the handle completely down to disengage the locking mechanism and pull out the rear fan unit.

To mount a fan unit, follow these instructions in the reverse order.

15.1.2 Replacing a Fan in the Unit



Figure 99: Disengaging the fan unit (a = green touch point)

- ▶ Pull (1) the locking handle (green) to disengage the fan.
- ▶ Remove the fan from the unit (2).

To mount a fan, follow these instructions in the reverse order.

16 Troubleshooting and Tips



CAUTION!

Please note the safety instructions in the [chapter “Important Notes” on page 21](#).

If a fault occurs, try to correct it as described

- in this chapter
- in the chapters for the components installed
- in the documentation for the connected devices
- in the help system of the individual programs

If you do not manage to correct the problem, proceed as follows:

- ▶ Make a note of the steps and the circumstances that led to the fault. Also make a note of any error messages displayed.
- ▶ Switch OFF the defective server blade or the system.
- ▶ Contact your customer service.

16.1 System Power LED Remains Unlit

The power LED (see [figure 15 on page 50](#)) remains unlit after you have switched ON your system:

Wrongly connected power cables

- ▶ Make sure that the power cables are correctly connected to the system power supply units and to the mains socket strip of the rack (see [section “Connecting the System to the Mains” on page 46](#)).

Power supply overloaded

- ▶ Unplug the power cables from the insulated sockets of the power supply units.
- ▶ Wait a few seconds and plug the power plugs into the insulated sockets again.
- ▶ Switch ON your system.

16.2 Front or Rear Identify/Fault LED Blinks Amber

If the front or rear identify/fault indicator blinks amber (see [section “Operating and Indicator Elements of the Basic Unit” on page 50](#)) one of the malfunctions described below may have occurred in the system:

One of the power supply units fails

The PSU status LED is unlit and/or the PSU fan failure LED blinks green if there is an error in the corresponding power supply unit, e.g. (see also [figure “Power supply unit: LEDs” on page 141](#)):

- General failure (alert or fan #1 shutdown)
 - Overtemperature (any of the fans are not working properly in the corresponding unit)
 - Overcurrent
 - Over- or undervoltage
 - The PSU is reaching the end of its life or is operating in an environment which exceeds the specified limits.
- ▶ Check the PSU status and/or fan failure LEDs to identify the defective unit and exchange it (see [section “Replacing a Power Supply Unit” on page 142](#)).

One of the fans in the rear fan modules has failed

Even though the system can continue operating without one of the fans in the rear fan modules, you should:

- ▶ Exchange the defective front fan module within a reasonable amount of time (see [section “Replacing the Fan Unit” on page 151](#) and [section “Replacing a Fan in the Unit” on page 153](#)).

Switch blade fails

The failure LED of the switch blade lights up if there is a general error there.

- ▶ Check the switch blade failure LEDs to identify the defective unit.
- ▶ If the switch blade is still indicated as defective, exchange it (see [section “Installing a LAN Switch Blade” on page 93](#)).

16.3 System Switches Itself OFF

Server management has detected an error

- ▶ In the *ServerView* program, check the error list or the error log file with the *SCU utility* and try to eliminate the error (see manual "[PRIMERGY BX Blade Server Systems: RemoteView Management Blade - User Interface Description](#)").

16.4 Screen Remains Dark

Monitor is switched OFF

- ▶ Switch ON your monitor.

Screen has gone blank

- ▶ Press any key on the keyboard.
or
- ▶ Deactivate screen blanking (screen saver). Enter the appropriate password.

Brightness control is set to dark

- ▶ Set the brightness control to light. For detailed information, see the operating manual supplied with your monitor.

Monitor power cable or data cable not connected

- ▶ Switch OFF the monitor.
- ▶ Check whether the power cable is properly connected to the monitor and to the grounded insulated socket.
- ▶ Check whether the data cable is properly connected to the system and monitor (if it is plugged in with a connector).
- ▶ Switch on the monitor.

16.5 Flickering Stripes on the Monitor Screen



CAUTION!

Switch OFF the server blade immediately.

Monitor does not support the set horizontal frequency

- ▶ Find out which horizontal frequency your monitor screen supports. You will find the horizontal frequency (also known as the line frequency or horizontal deflection frequency) in the documentation for your monitor.
- ▶ For how to set the correct horizontal frequency for your monitor, refer to the documentation for your operating system or the software for your screen controller and follow the procedure accordingly.

16.6 No Screen Display or Display Drifts

Wrong horizontal frequency or resolution selected (for the monitor or for the application program)

- ▶ Find out which horizontal frequency your monitor supports. You will find the horizontal frequency (also known as line frequency or horizontal deflection frequency) in the documentation for your monitor.
- ▶ For how to set the correct horizontal frequency for your monitor, refer to the documentation for your operating system or the software for your screen controller and follow the procedure accordingly.

16.7 No Mouse Pointer Displayed On the Screen

Mouse driver not loaded

- ▶ Check whether the mouse driver is properly installed and activated. Information on the mouse driver can be found in the documentation for the mouse, the operating system or the application program.

16.8 Floppy Disk Cannot Be Read/Written

- ▶ Check whether the write protection of the floppy disk is activated.
- ▶ Check the entry for the floppy disk drive in the BIOS Setup for the corresponding server blade.
- ▶ Check the BIOS Setup for the corresponding server blade to see whether the floppy disk drive controller and write permission are enabled.

16.9 Time and Date Are Not Correct

- ▶ Set the time and/or date in the operating system or in the BIOS Setup for the corresponding server blade.



If the time and date are repeatedly wrong when you switch on your server blade, you must change the lithium battery (see the manual for the relevant server blade type).

16.10 Server Blade Does Not Boot

The server blade does not boot after a defective hard disk drive has been replaced

Incorrect SCSI configuration (onboard SCSI HostRAID controller)

- ▶ In the SCSI configuration menu, check the settings for the hard disk drives (SCSI Device Configuration) and the additional settings (Advanced Configuration Options).

16.11 Defective Drive

Drives are identified as dead on system start

The configuration of the RAID controller is wrong.

- ▶ Check and correct the settings for the drives using the utility for the RAID controller.

For more details, see the manual for the RAID controller (on the ServerBooks CD under the heading “Controllers”).

Added drive is identified as defective

The RAID controller is not configured for the drive. The drive was probably installed while the system was switched off.

- ▶ You can configure the RAID controller for the drive after its installation using the relevant utility. For how to do this, see the documentation for the RAID controller (on the ServerBooks CD under the heading “Controllers”).

or

- ▶ Remove the drive and reinstall it with the system switched on.

If the drive is still identified as defective, you will need to replace it.

Abbreviations

ASR&R

Automatic Server Reconfiguration and Restart

ATA

Advanced Technology Attachment

BIOS

Basic Input-Output System

CD

Compact Disk

COM

Communication

CPU

Central Processing Unit

DBMS

Database Management System

DDR

Double Data Rate (RAM)

DIMM

Dual Inline Memory Module

DVD

Digital Video Disk

ECC

Error Correcting Code

EDC

Error Detection Code

EMC

Electromagnetic Compatibility

Abbreviations

ESD	Electrostatic Discharge
FC	Fibre Channel
GAM	Global Array Manager
HDD	Hard Disk Drive
HU	Height Unit
I/O	Input/Output
ID	Identification
IDE	Integrated Drive Electronics
IP	Internet Protocol
LAN	Local Area Network
LCD	Liquid Crystal Display
LED	Light-Emitting Diode
MRL	Manually Retention Latch
NIC	Network Interface Card

NMI	Non Maskable Interrupt
PCI	Peripheral Component Interconnect
PDA	Prefailure Detection and Analyzing
POST	Power Up Self Test
PSU	Power Supply Unit
RAID	Redundant Arrays of Independent Disks
ROM	Read-Only Memory
SAN	Storage Area Network
SAS	Serial Attached SCSI
SATA	Serial ATA
SCA	Single Connector Attachment
SCSI	Small Computer System Interface
SCU	Server Configuration Utility
SFP	Small Form Factor Pluggable

Abbreviations

USB

Universal Serial Bus

VGA

Video Graphics Adapter

VPD

Vital Product Data

WOL

Wakeup on LAN

Related Publications

PRIMERGY manuals are available in PDF format on the **ServerBooks DVD**. The ServerBooks DVD is part of the **PRIMERGY ServerView Suite**, delivered with each server system.

The PDF files for the manuals can also be downloaded free of charge from the Internet. The overview page showing the online documentation available on the Internet can be found at: <http://manuals.fujitsu-siemens.com> (select: industry standard servers).

- [1] **Safety**
- [2] **Ergonomics**
- [3] **Warranty**
- [4] **DataCenter Rack**
Technisches Handbuch/Technical Manual
- [5] **PRIMECENTER Rack**
Technisches Handbuch/Technical Manual
- [6] **PRIMERGY BX620 Server-Blade**
Operating Manual
- [7] **PRIMERGY BX620 S2 Server-Blade**
Operating Manual
- [8] **PRIMERGY BX630 Scalable Server-Blade**
Betriebsanleitung
- [9] **PRIMERGY BX660 Server-Blade**
Operating Manual
- [10] **PRIMERGY ServerView Suite
ServerStart**
User Manual
- [11] **PRIMERGY ServerView Suite
ServerView S2**
Server Management
User Manual

Related publications

- [12] **PRIMERGY ServerView Suite
ServerView**
Server Management
User Manual
- [13] **PRIMERGY ServerView Suite
RemoteView**
User Manual
- [14] **PRIMERGY RemoteDeploy**
User Guide
- [15] **PRIMERGY BX Blade Server Systems:
RemoteView Management Blade - User Interface Description**
User Guide
- [16] **PRIMERGY BX Blade Server Systems:
LAN Router and Switch Blade - User Interface Description**
User Guide
- [17] **PRIMERGY BX Blade Server Systems:
Cisco Catalyst Blade Switch 3040**
Getting Started Guide
- [18] **PRIMERGY BX Blade Server Systems:
Cisco Catalyst Blade Switch 3040**
Command Reference
- [19] **PRIMERGY BX Blade Server Systems:
Cisco Catalyst Blade Switch 3040**
Hardware Installation Guide
- [20] **PRIMERGY BX Blade Server Systems:
Cisco Catalyst Blade Switch 3040**
Software Configuration Guide
- [21] **PRIMERGY BX Blade Server Systems:
Cisco Catalyst Blade Switch 3040**
System Message Guide
- [22] **BX600 Digital KVM Switch**
Quick Installation Guide

- [23] **BX600 Digital KVM Switch**
User Guide

- [24] **BIOS-Setup**
Beschreibung/Reference Manual

Index

10 GBit CX4-Anschluss 84
10 GBit XFP-Anschluss 84

A

adding
 server blade 76
Adv. KVM blade 135
 connection panel 135
 indicator elements 135
Adv. KVM-Blade 137
approvals
 product safety 15
ASR&R 12
availability 12

B

Battery
 exchanging 128
 Management blade 128
BIOS
 security functions 69
BIOS update 13
BX600 basic unit installation steps
 overview 19

C

cables
 connecting 45
 disconnecting 45
carrier rail 39
CE label 15, 25
Class A Compliance Statement 26
component
 hot-swappable 12
components
 hardware/software 7
configuring
 server 13
connecting
 cables 45

 external devices 45
consumables 29
Control panel
 Ethernet pass-thru-blade 100
 FC switch blade 106
 LAN switch blade 90
 Management blade 126

D

data manipulation 8
data protection 69
date
 incorrect 159
delivery note 34
dimensions 16
disconnecting
 cables 45
Display Elements
 Power Unit 141
drive
 defective 159
dummy module
 installing 76
 LAN switch blade 94
 server blade 76

E

ECC 12
electrical data 15
electromagnetic compatibility 15, 25
EMC 15
environmental conditions 17
environmental protection 29

Index

- error
 - defective drive 159
 - display drifts 158
 - flickering stripes on screen 158
 - floppy disk cannot be read/
written 159
 - incorrect date 159
 - incorrect time 159
 - no display on screen 158
 - no mouse pointer 158
 - screen remains dark 157
 - server blade does not boot 159
 - system switches itself OFF 157
- Error Correcting Code 12
- ESD (devices sensitive to electrostatic
discharge) 25
- ESD-sensitive devices 25
- Ethernet pass-thru blade 99
 - connection panel 100
 - Control panel 100
 - control panel 100
 - Port assignment 101
 - slot 101
- exchanging
 - Battery 128
 - FC pass-thru blade 121
 - Management blade 130
- external devices
 - connecting 45
- F**
- fan module
 - front 12, 149
 - rear 12, 149
- fan unit
 - replacing 151
- fault
 - defective drive 159
 - display drifts 158
 - flickering stripes on screen 158
 - floppy disk cannot be read/
written 159
 - incorrect date 159
 - incorrect time 159
 - no display on screen 158
 - no mouse pointer 158
 - screen remains dark 157
 - server blade does not boot 159
 - system switches itself OFF 157
- FC pass-thru blade 113
 - connection panel 114
 - control panel 114
 - exchanging 121
 - Port assignment 117
 - slot 118
- FC switch blade
 - Control panel 106
 - Installing 111
 - Port assignment 108
- FCC statement 26
- Fibre Channel
 - pass-thru blade 113
 - SFP module 115
 - Switch blade 105
- flash EPROM 13
- floppy disk
 - cannot be read/written 159
- H**
- height units 38
- hot-swap
 - fan module 12
 - management blade 12
 - power supply unit 12
 - server blade 12
 - switch blade 12
- I**
- indicators
 - power supply unit 146
 - system 50
- information
 - additional 9
- installation steps overview 19

- installing
 - dummy module 76
 - FC switch blade 111
 - in the rack 35
 - LAN switch blade 93, 95
 - system 35
- K**
- KVM blade 133
 - connection panel 133
 - indicator elements 133
 - special cable 43
 - Standard version 133
- KVM-Blade
 - adv. 137
 - Anschlussfeld 137
 - Anzeigeelemente 137
- L**
- LAN switch blade 81
 - Control panel 90
 - dummy module 94
 - installing 93, 95
 - Port assignment 90
- LED
 - system power LED remains unlit 155
- lithium battery 24
- low-voltage directive 15, 25
- M**
- mains voltage
 - connecting the system 46
- Management blade 125
 - Battery 128
 - Control panel 126
 - exchanging 130
- meaning of the symbols 14
- model rating plate 34
- mouse
 - no mouse pointer on screen 158
- N**
- Netzteil 11, 12
- noise level 17
- notational conventions 14
- notes on safety 21
- O**
- operating elements
 - system 50
- overloading 13
- overview
 - BX600 basic unit installation steps 19
- P**
- packaging 34
- password on boot 69
- PDA 12, 13
- Port assignment
 - Ethernet pass-thru blade 101
 - FC pass-thru blade 117
 - FC switch blade 108
 - LAN switch blade 90
- power supply
 - power supply unit 12, 139
 - system 139
- power supply unit 12, 139
 - indicators 146
 - replacing 142
- Power Unit
 - Display Elements 141
 - property protection 69
- R**
- reliability 12
- replacing
 - fan unit 151
 - power supply unit 142
- routing cables 43
- S**
- safety standards 15
- saving energy 29

Index

- screen
 - display drifts 158
 - flickering stripes 158
 - no display 158
 - remains dark 157
 - security functions 8
 - password on boot 69
 - supervisor password 69
 - user password 69
 - server
 - data protection 69
 - property protection 69
 - transport 27
 - server blade
 - adding 76
 - does not boot 159
 - dummy module 76
 - server management 13
 - ServerStart 13
 - ServerView 13
 - supported functions 13
 - SFP module 115
 - standards 15
 - sticker 29
 - Stromversorgung
 - Netzteil 11, 12
 - supervisor password 69
 - Switch blade
 - Fibre Channel 105
 - LAN 94
 - Switch-Blade
 - Cisco Catalyst 3040 86, 88
 - SB9 10 Gbit Multimode 84
 - SB9 6x1Gbit 82
 - switch-OFF time
 - define 54
 - switch-ON time
 - define 54
 - switching OFF
 - system 53
 - switching ON
 - system 53
 - system
 - connecting mains voltage 46
 - front 50
 - height units 38
 - indicators 50
 - installing 35
 - operating elements 50
 - power supply 139
 - rear 52
 - routing cables 43
 - switches itself OFF (error) 157
 - switching OFF 53
 - switching ON 53
 - unpacking 34
 - ventilation 149
 - system power LED
 - remains unlit 155
- ## T
- target group 8
 - technical data 15
 - time
 - incorrect 159
 - transport damage 34
- ## U
- unpacking
 - system 34
 - user password 69
- ## V
- ventilation
 - fan in power supply unit 12, 149
 - fan module 12, 149
 - system 149
 - ventilation clearance 16
- ## W
- weight 16



Information on this document

On April 1, 2009, Fujitsu became the sole owner of Fujitsu Siemens Computers. This new subsidiary of Fujitsu has been renamed Fujitsu Technology Solutions.

This document from the document archive refers to a product version which was released a considerable time ago or which is no longer marketed.

Please note that all company references and copyrights in this document have been legally transferred to Fujitsu Technology Solutions.

Contact and support addresses will now be offered by Fujitsu Technology Solutions and have the format ...@ts.fujitsu.com.

The Internet pages of Fujitsu Technology Solutions are available at <http://ts.fujitsu.com/>...

and the user documentation at <http://manuals.ts.fujitsu.com>.

Copyright Fujitsu Technology Solutions, 2009

Hinweise zum vorliegenden Dokument

Zum 1. April 2009 ist Fujitsu Siemens Computers in den alleinigen Besitz von Fujitsu übergegangen. Diese neue Tochtergesellschaft von Fujitsu trägt seitdem den Namen Fujitsu Technology Solutions.

Das vorliegende Dokument aus dem Dokumentenarchiv bezieht sich auf eine bereits vor längerer Zeit freigegebene oder nicht mehr im Vertrieb befindliche Produktversion.

Bitte beachten Sie, dass alle Firmenbezüge und Copyrights im vorliegenden Dokument rechtlich auf Fujitsu Technology Solutions übergegangen sind.

Kontakt- und Supportadressen werden nun von Fujitsu Technology Solutions angeboten und haben die Form ...@ts.fujitsu.com.

Die Internetseiten von Fujitsu Technology Solutions finden Sie unter <http://de.ts.fujitsu.com/>..., und unter <http://manuals.ts.fujitsu.com> finden Sie die Benutzerdokumentation.

Copyright Fujitsu Technology Solutions, 2009

Free Manuals Download Website

<http://myh66.com>

<http://usermanuals.us>

<http://www.somanuals.com>

<http://www.4manuals.cc>

<http://www.manual-lib.com>

<http://www.404manual.com>

<http://www.luxmanual.com>

<http://aubethermostatmanual.com>

Golf course search by state

<http://golfingnear.com>

Email search by domain

<http://emailbydomain.com>

Auto manuals search

<http://auto.somanuals.com>

TV manuals search

<http://tv.somanuals.com>