

FUJITSU Server

PRIMEQUEST 2000 Series

Hardware Installation Manual



Preface

This manual describes the functions and features of the PRIMEQUEST 2000 series. The manual is intended for system administrators.

For details on the regulatory compliance statements and safety precautions, see the *PRIMEQUEST 2000 Series Safety and Regulatory Information* (C122-E171XA).

Errata and addenda for the manual

The *PRIMEQUEST 2000 Series Errata and Addenda* (C122-E182EN) provides errata and addenda for the manual. Read the *PRIMEQUEST 2000 Series Errata and Addenda* (C122-E182EN) thoroughly in reference to the manual.

Organization of this manual

This manual is organized as follows.

[CHAPTER 1 Installation Data](#)

Chapter 1 provides various useful information on PRIMEQUEST 2000 series installation. The information includes device configuration details, device outline drawings, installation specifications, and various layout diagrams.

[CHAPTER 2 Connected Information](#)

Chapter 2 describes the cables used with the PRIMEQUEST 2000 series and provides an overview of cable connections.

[CHAPTER 3 Notes on Carrying In and Installing the Product](#)

Chapter 3 provides notes on carrying in and installing the PRIMEQUEST 2000 series server.

[Appendix A Racks](#)

Appendix A provides various information on the mounting racks for the PRIMEQUEST 2000 series and PCI_Box.

Revision History

Edition	Date	Revised location (type) (*1)	Description
1	2014-02-18	-	-

1: Chapter, section, and item numbers in the "Revised location" column refer to those in the latest edition of the document. However, a number marked with an asterisk () denotes a chapter, section, or item in a previous edition of the document.

Product operating environment

This product is a computer intended for use in a computer room environment. For details on the product operating environment, see the following manual:

PRIMEQUEST 2000 Series Hardware Installation Manual (C122-H007EN)

Safety Precautions

Alert messages

This manual uses the following alert messages to prevent users and bystanders from being injured and to prevent property damage.



This indicates a hazardous (potentially dangerous) situation that is likely to result in death or serious personal injury if the user does not perform the procedure correctly.



This indicates a hazardous situation that could result in minor or moderate personal injury if the user does not perform the procedure correctly. This also indicates that damage to the product or other property may occur if the user does not perform the procedure correctly.

Important

This indicates information that could help the user use the product more efficiently.

Alert messages in the text

An alert statement follows an alert symbol. An alert statement is indented on both ends to distinguish it from regular text. Similarly, one space line is inserted before and after the alert statement.



Only Fujitsu certified service engineers should perform the following tasks on this product and the options provided by Fujitsu. Customers must not perform these tasks under any circumstances. Otherwise, electric shock, injury, or fire may result.

- Newly installing or moving equipment
- Removing the front, rear, and side covers
- Installing and removing built-in options
- Connecting and disconnecting external interface cables
- Maintenance (repair and periodic diagnosis and maintenance)

The List of important alert items table lists important alert items.

List of important alert items

This manual does not contain important alert items.

Warning labels



Never remove the warning labels.

Warning label location (the main cabinet top)

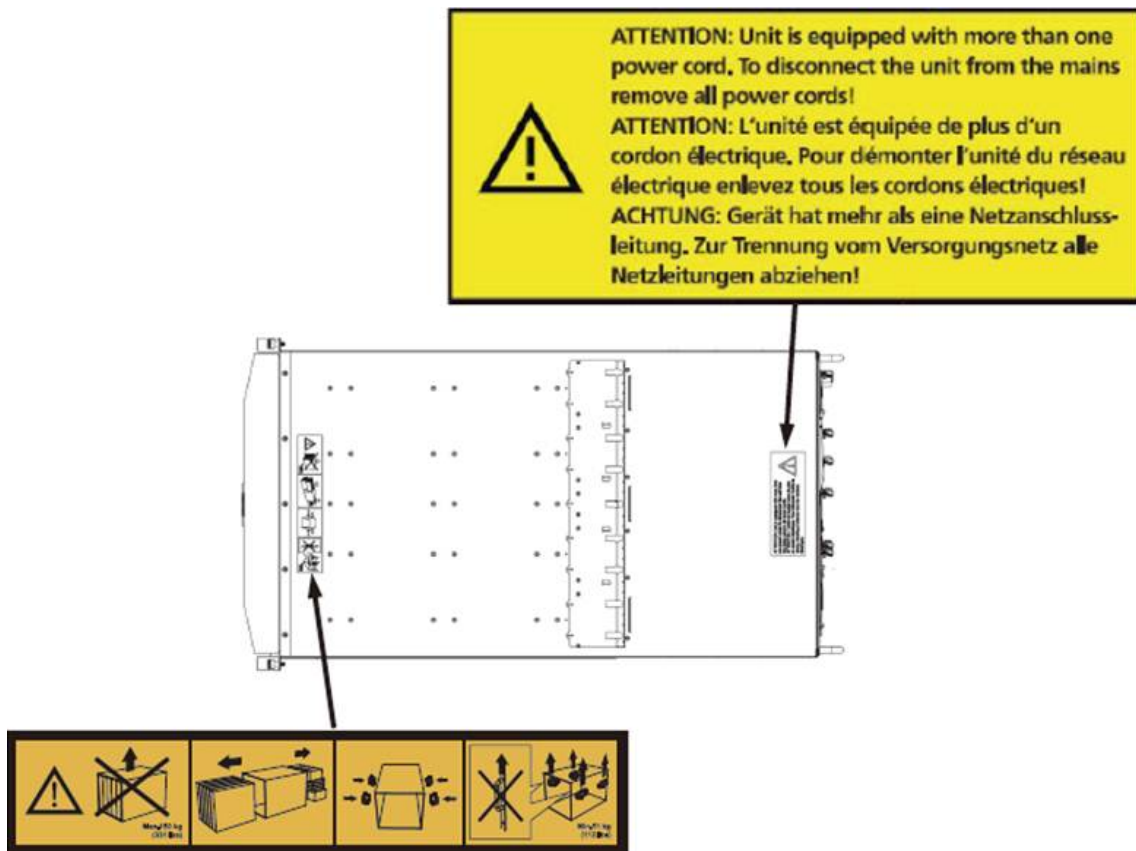

Warning label location (the main cabinet left)

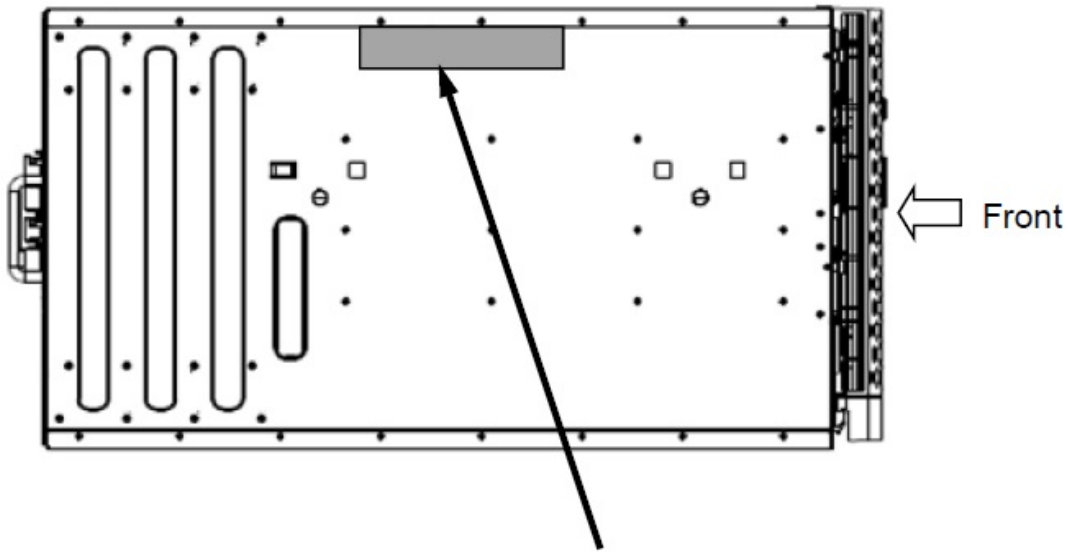

<p>注意 CAUTION ATTENTION 感電 触电 内部には高電圧部分があり、感電する恐れがあります。保守担当者以外の方は内部に触れないでください。 HAZARDOUS VOLTAGE. SERVICE ENGINEER ONLY TOUCH THE INSIDE. 装置内有高电压部分，有引起触电的危险。除保养担当者之外，请勿触摸装置内部。 TENSIONS DANGEREUSES. SEUL UN INGÉNIEUR PEUT VÉRIFIER L'INTÉRIEUR.</p>	<p>注意 CAUTION ATTENTION 本機器を搭載する前に、設置マニュアルを見てください。 SEE INSTALLATION INSTRUCTIONS BEFORE INSTALLING THIS UNIT. 请务必先阅读本装置安装手册之后，再进行机器的安装。 VOIR LE MANUEL D'INSTRUCTIONS AVANT D'INSTALLER CET UNITÉ.</p>	<p>注意 CAUTION ATTENTION 保守時は静電気を除去すること。 ELECTROSTATIC SENSITIVE DEVICES. 维护保养时必须采取防静电措施。 CIRCUITS SENSIBLES A L'ELECTRICITÉ STATIQUE.</p>
--	---	--

Warning label location (PCI_Box)

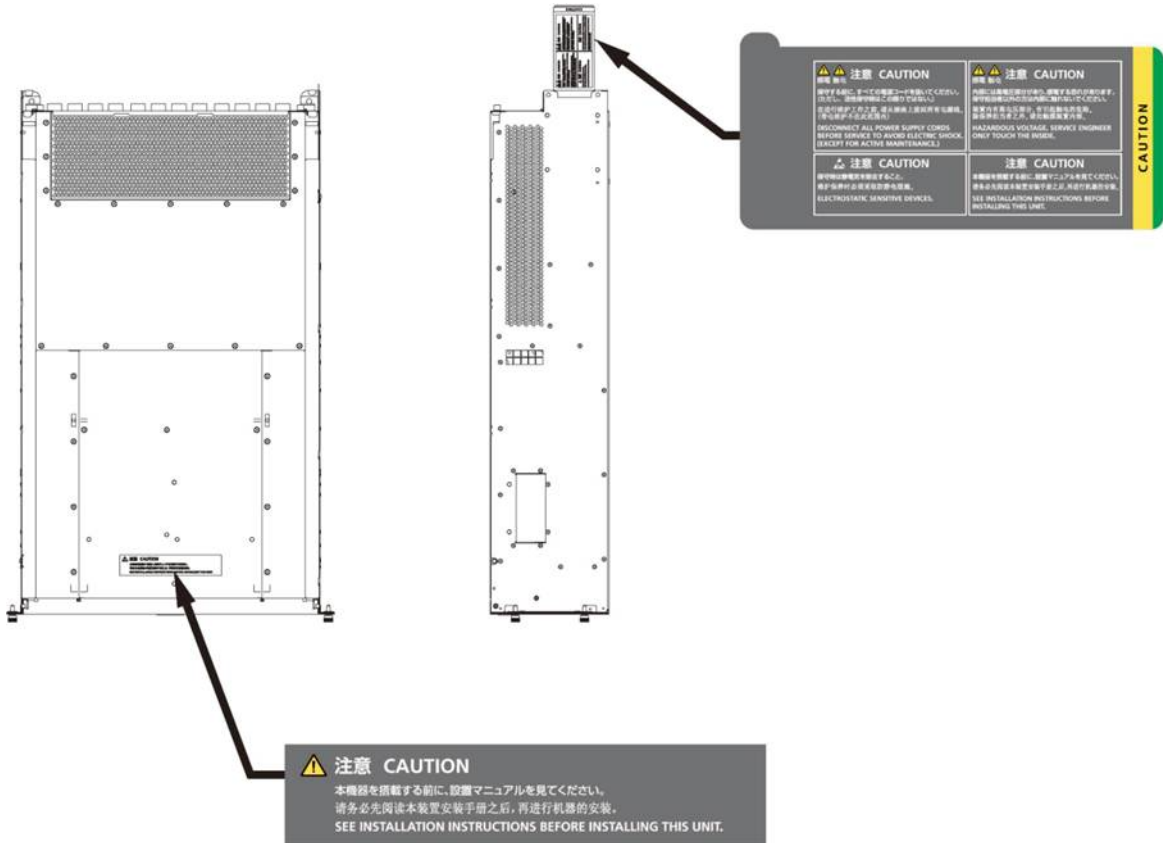

注意 CAUTION
 本機器を搭載する前に、設置マニュアルを見てください。
 请务必先阅读本装置安装手册之后，再进行机器的安装。
 SEE INSTALLATION INSTRUCTIONS BEFORE INSTALLING THIS UNIT.

注意 CAUTION
 感電 触电
 内部には高電圧部分があり、感電する恐れがあります。保守担当者以外の方は内部に触れないでください。
 HAZARDOUS VOLTAGE. SERVICE ENGINEER ONLY TOUCH THE INSIDE.

注意 CAUTION
 本機器を搭載する前に、設置マニュアルを見てください。
 请务必先阅读本装置安装手册之后，再进行机器的安装。
 SEE INSTALLATION INSTRUCTIONS BEFORE INSTALLING THIS UNIT.

注意 CAUTION
 保守時は静電気を除去すること。
 ELECTROSTATIC SENSITIVE DEVICES.
 维护保养时必须采取防静电措施。
 CIRCUITS SENSIBLES A L'ELECTRICITÉ STATIQUE.

CAUTION

Notes on Handling the Product

About this product

This product is designed and manufactured for standard applications. Such applications include, but are not limited to, general office work, personal and home use, and general industrial use. The product is not intended for applications that require extremely high levels of safety to be guaranteed (referred to below as "safety-critical" applications). Use of the product for a safety-critical application may present a significant risk of personal injury and/or death. Such applications include, but are not limited to, nuclear reactor control, aircraft flight control, air traffic control, mass transit control, medical life support, and missile launch control. Customers shall not use the product for a safety-critical application without guaranteeing the required level of safety. Customers who plan to use the product in a safety-critical system are requested to consult the Fujitsu sales representatives in charge.

Storage of accessories

Keep the accessories in a safe place because they are required for server operation.

Adding optional products

For stable operation of the PRIMEQUEST 2000 series server, use only a Fujitsu-certified optional product as an added option.

Note that the PRIMEQUEST 2000 series server is not guaranteed to operate with any optional product not certified by Fujitsu.

Maintenance



Only Fujitsu certified service engineers should perform the following tasks on this product and the options provided by Fujitsu. Customers must not perform these tasks under any circumstances. Otherwise, electric shock, injury, or fire may result.

- Newly installing or moving equipment
- Removing the front, rear, and side covers
- Installing and removing built-in options
- Connecting and disconnecting external interface cables
- Maintenance (repair and periodic diagnosis and maintenance)



Only Fujitsu certified service engineers should perform the following tasks on this product and the options provided by Fujitsu. Customers must not perform these tasks under any circumstances. Otherwise, product failure may result. PRIMEQUEST 2000 Series General Description

- Unpacking an optional Fujitsu product, such as an optional adapter, delivered to the customer

Modifying or recycling the product



Modifying this product or recycling a secondhand product by overhauling it without prior approval may result in personal injury to users and/or bystanders or damage to the product and/or other property.

Note on erasing data from hard disks when disposing of the product or transferring it

Disposing of this product or transferring it as is may enable third parties to access the data on the hard disk and use it for unforeseen purposes. To prevent the leakage of confidential information and important data, all of the data on the hard disk must be erased before disposal or transfer of the product.

However, it can be difficult to completely erase all of the data from the hard disk. Simply initializing (reformatting) the hard disk or deleting files on the operating system is insufficient to erase the data, even though the data appears at a glance to have been erased. This type of operation only makes it impossible to access the data from the operating system.

Malicious third parties can restore this data.

If you save your confidential information or other important data on the hard disk, you should completely erase the data, instead of simply carrying out the aforementioned operation, to prevent the data from being restored. To prevent important data on the hard disk from being leaked when the product is disposed of or transferred, you will need to take care to erase all the data recorded on the hard disk on your own responsibility.

Furthermore, if a software license agreement restricts the transfer of the software (operating system and application software) on the hard disk in the server or other product to a third party, transferring the product without deleting the software from the hard disk may violate the agreement. Adequate verification from this point of view is also necessary.

Product and service inquiries

For all product use and technical inquiries, contact the distributor where you purchased your product, or a Fujitsu sales representative or systems engineer (SE). If you do not know the appropriate contact address for inquiries about the PRIMEQUEST 2000 series, use the Fujitsu contact line.

Fujitsu contact line

We accept Web inquiries. For details, visit our website:

https://www-s.fujitsu.com/global/contact/computing/PRMQST_feedback.html

Warranty

If a component failure occurs during the warranty period, we will repair it free of charge in accordance with the terms of the warranty agreement. For details, see the warranty.

Before requesting a repair

If a problem occurs with the product, confirm the problem by referring to 11.2 Troubleshooting in the *PRIMEQUEST 2000 Series Administration Manual* (C122-E175ENEN). If the error recurs, contact your sales representative or a field engineer. Confirm the model name and serial number shown on the label affixed to the right front of the device and report it. Also check any other required items beforehand according to 11.2 Troubleshooting in the *PRIMEQUEST 2000 Series Administration Manual* (C122-E175ENEN).

The system settings saved by the customer will be used during maintenance.

Manual

How to use this manual

This manual contains important information about the safe use of this product. Read the manual thoroughly to understand the information in it before using this product. Be sure to keep this manual in a safe and convenient location for quick reference.

Fujitsu makes every effort to prevent users and bystanders from being injured and to prevent property damage. Be sure to use the product according to the instructions in this manual.

Manuals for the PRIMEQUEST 2000 series

The following manuals have been prepared to provide you with the information necessary to use the PRIMEQUEST 2000 series.

You can access HTML versions of these manuals at the following sites:

Japanese-language site: <http://jp.fujitsu.com/platform/server/primequest/manual/2000/>

Global site: <http://www.fujitsu.com/global/services/computing/server/primequest/>

<http://manuals.ts.fujitsu.com/>

Title	Description	Manual code
<i>PRIMEQUEST 2000 Series Getting Started Guide</i>	Describes what manuals you should read and how to access important information after unpacking the PRIMEQUEST 2000 series server. (This manual comes with the product.)	C122-E170XA
<i>PRIMEQUEST 2000 Series Safety and Regulatory Information</i>	Contains important information required for using the PRIMEQUEST 2000 series safely.	C122-E171XA
<i>PRIMEQUEST 2000 Series Errata and Addenda</i>	Provides errata and addenda for the PRIMEQUEST 2000 series manuals. This manual will be updated as needed.	C122-E182EN
<i>PRIMEQUEST 2000 Series General Description</i>	Describes the functions and features of the PRIMEQUEST 2000 series.	C122-B025EN
<i>SPARC Enterprise/ PRIMEQUEST Common Installation Planning Manual</i>	Provides the necessary information and concepts you should understand for installation and facility planning for SPARC Enterprise and PRIMEQUEST installations.	C120-H007EN
<i>PRIMEQUEST 2000 Series Hardware Installation Manual</i>	Includes the specifications of and the installation location requirements for the PRIMEQUEST 2000 series.	C122-H007EN
<i>PRIMEQUEST 2000 Series Installation Manual</i>	Describes how to set up the PRIMEQUEST 2000 series server, including the steps for installation preparation, initialization, and software installation.	C122-E174EN
<i>PRIMEQUEST 2000 Series User Interface Operating Instructions</i>	Describes how to use the Web-UI and UEFI to assure proper operation of the PRIMEQUEST 2000 series server.	C122-E176EN
<i>PRIMEQUEST 2000 Series Administration Manual</i>	Describes how to use tools and software for system administration and how to maintain the system (component replacement and error notification).	C122-E175EN
<i>PRIMEQUEST 2000 Series Tool Reference</i>	Provides information on operation methods and settings, including details on the MMB, PSA, and UEFI functions.	C122-E177EN

Title	Description	Manual code
<i>PRIMEQUEST 2000 Series Message Reference</i>	Lists the messages that may be displayed when a problem occurs during operation and describes how to respond to them.	C122-E178EN
<i>PRIMEQUEST 2000 Series REMCS Installation Manual</i>	Describes REMCS service installation and operation	C122-E180EN
<i>PRIMEQUEST 2000 Series Glossary</i>	Defines the PRIMEQUEST 2000 series related terms and abbreviations.	C122-E179EN

Related manuals

The following manuals relate to the PRIMEQUEST 2000 series.

You can access these manuals at the following site:

<http://www.fujitsu.com/global/services/computing/server/primequest/>

<http://manuals.ts.fujitsu.com/>

Contact your sales representative for inquiries about the ServerView manuals

Title	Description	Manual code
<i>ServerView Suite ServerView Operations Manager Quick Installation (Windows)</i>	Describes how to install and start ServerView Operations Manager in a Windows environment.	None
<i>ServerView Suite ServerView Operations Manager Quick Installation (Linux)</i>	Describes how to install and start ServerView Operations Manager in a Linux environment.	None
<i>ServerView Suite ServerView Installation Manager</i>	Describes the installation procedure using ServerView Installation Manager.	None
<i>ServerView Suite ServerView Operations Manager Server Management</i>	Provides an overview of server monitoring using ServerView Operations Manager, and describes the user interface of ServerView Operations Manager.	None
<i>ServerView Suite ServerView RAID Management User Manual</i>	Describes RAID management using ServerView RAID Manager.	None
<i>ServerView Suite Basic Concepts</i>	Describes basic concepts about ServerView Suite.	None
<i>ServerView Operations Manager Installation ServerView Agents for Linux</i>	Describes installation and update installation of ServerView Linux Agent.	None
<i>ServerView Operations Manager Installation ServerView Agents for Windows</i>	Describes installation and update installation of ServerView Windows Agent.	None
<i>ServerView Mission Critical Option User Manual</i>	Describes the necessary functions unique to PRIMEQUEST (notification via the MMB, hot replacement command) and ServerView Mission Critical Option (SVMco), which is required for supporting these functions..	None
<i>ServerView RAID Manager VMware vSphere ESXi 5 Installation Guide</i>	Describes the installation and settings required to use ServerView RAID Manager on the VMware vSphere ESXi 5 server.	None

Title	Description	Manual code
<i>MegaRAID SAS Software</i>	Provides technical information on using RAID controllers. Refer to the manual from the SVS-ServerView Suite ServerBooks DVD(Manual)2 supplied with the product or from the following URL: The Fujitsu Technology Solutions manuals server http://manuals.ts.fujitsu.com/	None
<i>MegaRAID SAS Device Driver Installation</i>	Provides technical information on using RAID controllers. Refer to the manual from the SVS-ServerView Suite ServerBooks DVD(Manual)2 supplied with the product or from the following URL: The Fujitsu Technology Solutions manuals server http://manuals.ts.fujitsu.com/	None
<i>Modular RAID Controller Installation Guide</i>	Provides technical information on using RAID controllers. Refer to the manual from the SVS-ServerView Suite ServerBooks DVD(Manual)2 supplied with the product or from the following URL: The Fujitsu Technology Solutions manuals server http://manuals.ts.fujitsu.com/	None

Abbreviations

This manual uses the following product name abbreviations.

Formal product name	Abbreviation
Microsoft® Windows Server® 2012 R2 Datacenter	Windows, Windows Server 2012
Microsoft® Windows Server® 2012 R2 Standard	
Microsoft® Windows Server® 2012 Datacenter	
Microsoft® Windows Server® 2012 Standard	
Microsoft® Windows Server® 2008 R2 Standard	Windows, Windows Server 2008
Microsoft® Windows Server® 2008 R2 Enterprise	
Microsoft® Windows Server® 2008 R2 Datacenter	
Red Hat® Enterprise Linux® 6 (for Intel64)	Linux, RHEL6, RHEL
Novell (R) SUSE(R) LINUX Enterprise Server 11 Service Pack 3	SLES11 SP3
Oracle Linux 6 (x86_64)	Oracle Linux, Oracle Linux 6
VMware vSphere (R) 5	VMware, vSphere 5.x, VMware 5, VMware 5.x
VMware (R) ESXi (TM) 5	ESXi, ESXi 5, ESXi 5.x

Trademarks

- Microsoft, Windows, and Windows Server are trademarks or registered trademarks of Microsoft Corporation in the United States and/or other countries.
- Linux is a registered trademark of Linus Torvalds.
- Red Hat, the Shadowman logo and JBoss are registered trademarks of Red Hat, Inc. in the U.S. and other countries.
- Oracle and Java are registered trademark of Oracle Corporation and its related company.
- Intel, Intel logo, Intel Inside, Intel Inside logo, Intel Atom, Intel Atom Inside, Intel Core, Core Inside, Intel vPro, vPro

Inside, Celeron, Celeron Inside, Itanium, Itanium Inside, Pentium, Pentium Inside, Xeon, Xeon Phi, Xeon Inside, Ultrabook are trademarks or registered trademarks of Intel Corporation.

- Ethernet is a registered trademark of Fuji Xerox Co., Ltd. in Japan and is a registered trademark of Xerox Corp. in the United States and other countries.
- VMware is a trademark or registered trademark of VMware, Inc. in the United States and other countries.
- Novell and SUSE Linux Enterprise Server are trademarks of Novell, Inc.
- Xen is a trademark or registered trademark of Citrix Systems, Inc. or its subsidiaries in the United States and other countries.
- Other company names and product names are the trademarks or registered trademarks of their respective owners.
- Trademark indications are omitted for some system and product names in this manual.

Notation

This manual uses the following fonts and symbols to express specific types of information.

Font or symbols	Meaning	Example
<i>italics</i>	Title of a manual that you should refer to	See the <i>PRIMEQUEST 2000 Series Installation Manual (C122-E174EN)</i> .
[]	Window names as well as the names of buttons, tabs, and drop-down menus in windows are enclosed in brackets.	Click the [OK] button.

Notation for the CLI (command line interface)

The following notation is used for commands.

Command syntax

Command syntax is represented as follows.

- Variables requiring the entry of a value are enclosed in angle brackets < >.
- Optional elements are enclosed in brackets [].
- Options for optional keywords are grouped in | (stroke) separated lists enclosed in brackets [].
- Options for required keywords are grouped in | (stroke) separated lists enclosed in braces { }.

Command syntax is written in a box.

Remarks

The command output shown in the PDF manuals may include line feeds at places where there is no line feed symbol (\ at the end of the line)

Notes on notations

- If you have a comment or request regarding this manual, or if you find any part of this manual unclear, please take a moment to share it with us by filling in the form at the following webpage, stating your points specifically, and sending the form to us:
https://www-s.fujitsu.com/global/contact/computing/PRMQST_feedback.html
- The contents of this manual may be revised without prior notice.
- In this manual, the Management Board and MMB firmware are abbreviated as "MMB."
- In this manual, IOU_10GbE and IOU_1GbE are collectively referred to as IO Units.
- Screenshots contained in this manual may differ from the actual product screen displays.
- The IP addresses, configuration information, and other such information contained in this manual are display examples and differ from that for actual operation.

- The PDF file of this manual is intended for display using Adobe® Reader® in single page viewing mode at 100% zoom.

This manual shall not be reproduced or copied without the permission of Fujitsu Limited.

Copyright 2014 FUJITSU LIMITED

Contents

Preface.....	i
CHAPTER 1 Installation Data.....	1
1.1 Configuration Contents of Device.....	1
1.2 External Overview of Device.....	1
1.2.1 External Overview of Device (Main equipment).....	1
1.2.2 External Overview of Device (PCI_Box).....	5
1.3 Installation Specifications.....	6
1.3.1 Installation specifications (PRIMEQUEST 2400E).....	6
1.3.2 Installation Specifications (PRIMEQUEST 2800E).....	8
1.3.3 Installation Specifications (PRIMEQUEST 2800B).....	10
1.3.4 Installation Specifications (PCI_Box).....	12
1.4 Installation Area.....	13
1.5 Flow of Cooling Air and Exhaust Air of Installation.....	14
1.5.1 Flow of Cooling Air and Exhaust Air (Main Cabinet).....	14
1.5.2 Flow of Cooling Air and Exhaust (PCI_Box).....	14
1.6 Installation Environment.....	15
1.6.1 Dust.....	15
1.6.2 Corrosive Gas.....	15
1.6.3 Sea Water (Salt Damage).....	15
1.7 Safety Measures.....	15
CHAPTER 2 Connected Information.....	16
2.1 Connection summary.....	16
2.2 Connection of signal cable.....	17
2.2.1 Basic interface and peripheral.....	17
2.2.2 Details of external interface connection.....	17
2.3 Power cable connection.....	22
2.3.1 Power Supply Cable Connection (PRIMEQUEST 2400E).....	22
2.3.2 Power Cables Connections (PRIMEQUEST 2800E/2800B).....	25
2.3.3 Power Cable Connections (PCI_Box).....	27
2.4 Connection Specifications of Input Power.....	30
2.4.1 Input Power Connection Specifications (Base Cabinet).....	30
2.4.2 Input Power Supply Connection Specifications (PCI_Box).....	30
2.4.3 Power Distribution Box and Distribution Panel.....	31
2.5 Free Access Underfloor Connection of Power Cable.....	31
2.6 Cutoff Characteristics of Distribution Panel (At the time of connecting power distribution box).....	32
CHAPTER 3 Notes on Carrying In and Installing the Product.....	34
3.1 Elevator Load Conditions.....	34
3.2 Earthquake Preparedness Measures.....	34
Appendix A Racks.....	35
A.1 Rack Mounting.....	35
A.2 Rack Mounting Requirements.....	35
A.2.1 Requirements for mounting in a Fujitsu 19-inch rack.....	35

A.2.2 Requirements for mounting in a third party's rack..... 37

Figures

FIGURE 1.1 PRIMEQUEST 2400E/2800E front view	1
FIGURE 1.2 PRIMEQUEST 2400E/2800E rear view	2
FIGURE 1.3 PRIMEQUEST 2400E/2800E top view.....	2
FIGURE 1.4 PRIMEQUEST 2400E/2800E right side view.....	2
FIGURE 1.5 PRIMEQUEST 2800B front view	3
FIGURE 1.6 PRIMEQUEST 2800B rear view	3
FIGURE 1.7 PRIMEQUEST 2800B top view.....	3
FIGURE 1.8 PRIMEQUEST 2800B right side view.....	4
FIGURE 1.9 Front View of PCI_Box.....	5
FIGURE 1.10 Rear View of PCI_Box.....	5
FIGURE 1.11 Top View of PCI_Box.....	5
FIGURE 1.12 Right Side View of PCI_Box.....	5
FIGURE 1.13 Service Area at the time of installing 19 inch rack model	13
FIGURE 1.14 Flow of Cooling Air and Exhaust Air (Main Cabinet).....	14
FIGURE 1.15 Flow of Cooling Air and Exhaust (PCI_Box)	14
FIGURE 2.1 Summary of Device Connection.....	16
FIGURE 2.2 External interface connection figure of (PRIMEQUEST 2400E (Front surface))	18
FIGURE 2.3 External interface connection figure of (PRIMEQUEST 2400E (Back surface))	18
FIGURE 2.4 External interface connection figure of (PRIMEQUEST 2800E (Front surface))	19
FIGURE 2.5 External interface connection figure of (PRIMEQUEST 2800E (Back surface))	19
FIGURE 2.6 External interface connection figure of (PRIMEQUEST 2800B (Front surface))	20
FIGURE 2.7 External interface connection figure of (PRIMEQUEST 2800B (Back surface))	20
FIGURE 2.8 Details of external interface (MMB).....	21
FIGURE 2.9 Details of external interface (IOU_1GbE).....	21
FIGURE 2.10 Details of external interface (IOU_10GbE).....	21
FIGURE 2.11 Details of external interface (DU).....	21
FIGURE 2.12 Details of external interface (PCI_Box).....	22
FIGURE 2.13 100V Standard Power Feed Configuration (Single power feed, no Redundant Power Feed)	22
FIGURE 2.14 100V Redundant Power Feed Configuration (Single power feed, Redundant Power Feed)	23
FIGURE 2.15 Standard Configuration of 200 V (single power feed, no redundant power feed) with Power Distribution Box Connection.....	23
FIGURE 2.16 200 V Redundant Power Feed Configuration (single power feed, redundant power feed) with Power Distribution Box Connection.....	24
FIGURE 2.17 200 V Dual Power Feed Configuration with Power Distribution Box Connection.....	24
FIGURE 2.18 200V Standard Configuration (single power feed and no redundant power feed) with Power Distribution Box Connection.....	25
FIGURE 2.19 200 V Redundant Power Feed Configuration (single power feed, redundant power feed) with Power Distribution Box Connection.....	26
FIGURE 2.20 200 V Dual Power Feed Configuration with Power Distribution Box Connection.....	27
FIGURE 2.21 100 V Configuration (Single power feed, no Redundant power feed).....	27
FIGURE 2.22 100 V Redundant power feed configuration (Single power feed, redundant power feed)	28
FIGURE 2.23 200V Standard configuration (single power feed, no redundant power feed) power distribution box connection	28

FIGURE 2.24 200 V Redundant Power Feed Configuration (Single power feed, Redundant Power Feed) Power Distribution Box Connection..... 29

FIGURE 2.25 200 V Dual Power Feed Configuration with Power Distribution Box Connection..... 29

FIGURE 2.26 When Underfloor Height is less than 300mm (11.8 in) 31

FIGURE 2.27 When the under floor height is 300 mm (11.8 in) or more..... 31

FIGURE 2.28 Characteristics of Breaker of Distribution Panel..... 33

FIGURE A.1 Example of rack mounting..... 36

FIGURE A.2 Length of rack..... 38

FIGURE A.3 Width of rack..... 38

FIGURE A.4 Format of rack posts 39

Tables

TABLE 1.1 Name and Contents of Configuration of Each device.....	1
TABLE 1.2 Installation Specifications (PRIMEQUEST 2400E).....	6
TABLE 1.3 Installation Specifications (PRIMEQUEST 2800E).....	8
TABLE 1.4 Installation Specifications (PRIMEQUEST 2800B).....	10
TABLE 1.5 Installation Specifications (PCI_Box)	12
TABLE 1.6 Permissible Level of Corrosive Gas.....	15
TABLE 2.1 Notes for Device connection	17
TABLE 2.2 Power Cable Specifications (Base Cabinet).....	30
TABLE 2.3 Power Cable Specification (PCI_Box).....	30
TABLE 2.4 Power Supply Cable Specifications of Power Distribution Box and Distribution Panel.....	31
TABLE 2.5 Characteristic Condition of Distribution Panel Breaker	32
TABLE 3.1 Elevator load conditions.....	34
TABLE A.1 Recommended racks for mounting.....	35
TABLE A.2 PRIMEQUEST 2000 series external dimensions.....	35
TABLE A.3 Structural condition of rack.....	37

CHAPTER 1 Installation Data

It explains the various data used while installing various drawings for device configuration, device overview, installation specification and layout.

1.1 Configuration Contents of Device

It shows the name and contents of configuration of each device.

TABLE 1.1 Name and Contents of Configuration of Each device

Equipment Name	Content Configuration	Size (Height)
PRIMEQUEST 2400E	Maximum 2 SB (Maximum 4 CPU), Maximum 4 IOU are available.	10 U
PRIMEQUEST 2800E/2800B	Maximum 4 SB (Maximum 8 CPU), Maximum 4 IOU are available.	
PCI_Box	Device for extending PCI Express Slot. Maximum 4 units can be connected in PRIMEQUEST 2400E/2800E. One PCI_Box has 12 PCI Express slots.	4U

Remarks

Each device shown in "TABLE 1.1 Name and Contents of Configuration of Each device" is installed in 19 inch rack of EIA standard.

For the details on 19 inch rack, contact the distributor where you purchased your product, or your sales representative.

1.2 External Overview of Device

This section describes the External Overview of each equipment.

1.2.1 External Overview of Device (Main equipment)

External Overview of device (Front view, Rear view, Top view, Right side view) of PRIMEQUEST 2000 Series is shown below.

PRIMEQUEST 2400E/2800E

FIGURE 1.1 PRIMEQUEST 2400E/2800E front view

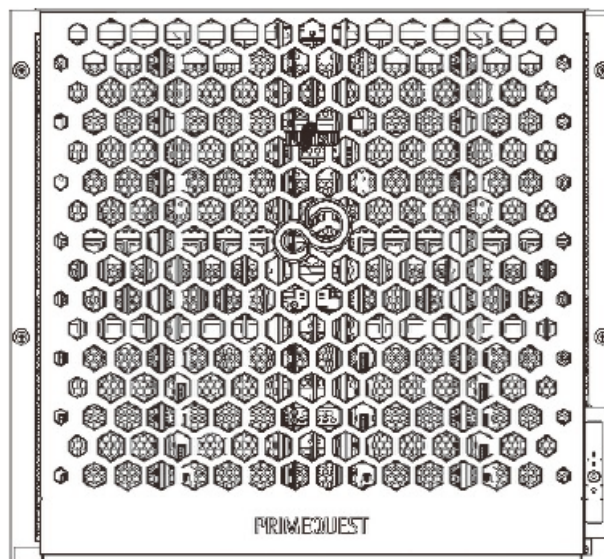

FIGURE 1.2 PRIMEQUEST 2400E/2800E rear view

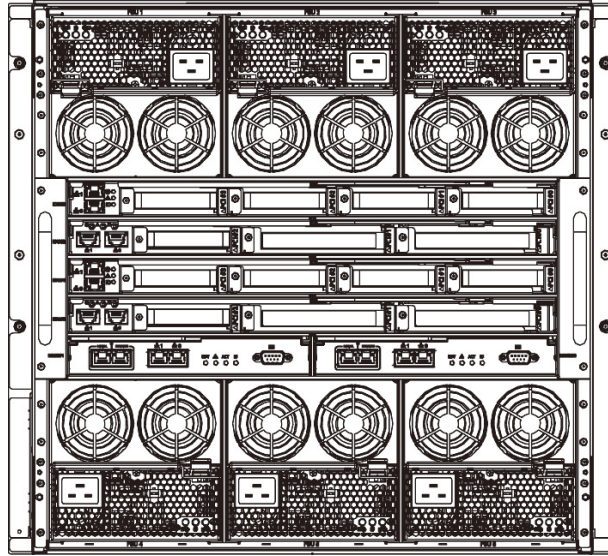

FIGURE 1.3 PRIMEQUEST 2400E/2800E top view

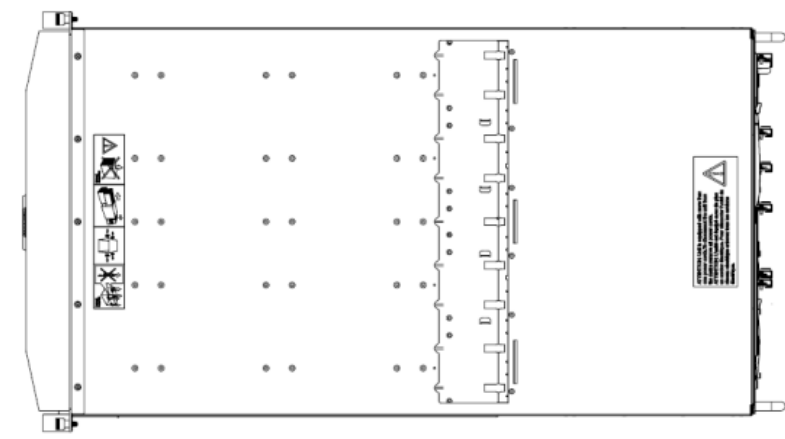
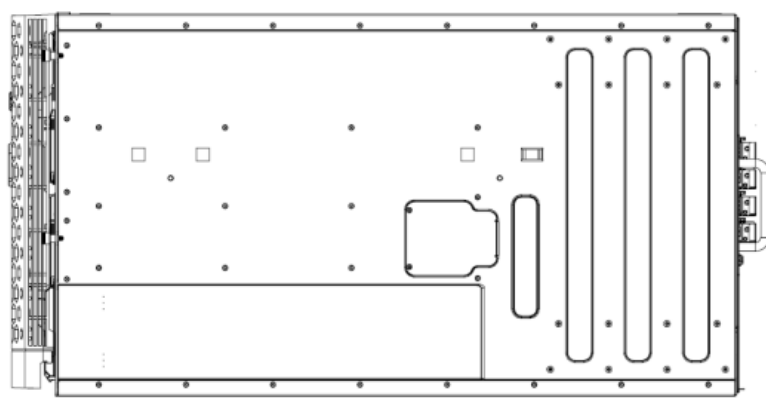

FIGURE 1.4 PRIMEQUEST 2400E/2800E right side view



PRIMEQUEST 2800B

FIGURE 1.5 PRIMEQUEST 2800B front view

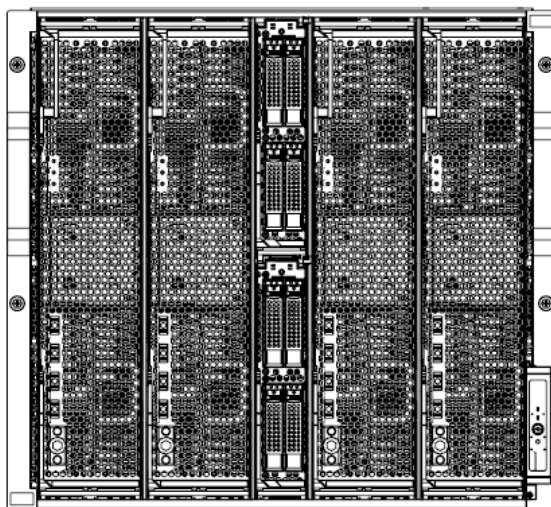

FIGURE 1.6 PRIMEQUEST 2800B rear view

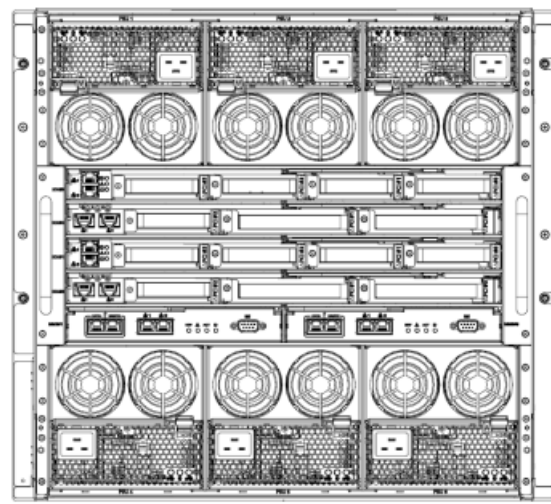

FIGURE 1.7 PRIMEQUEST 2800B top view

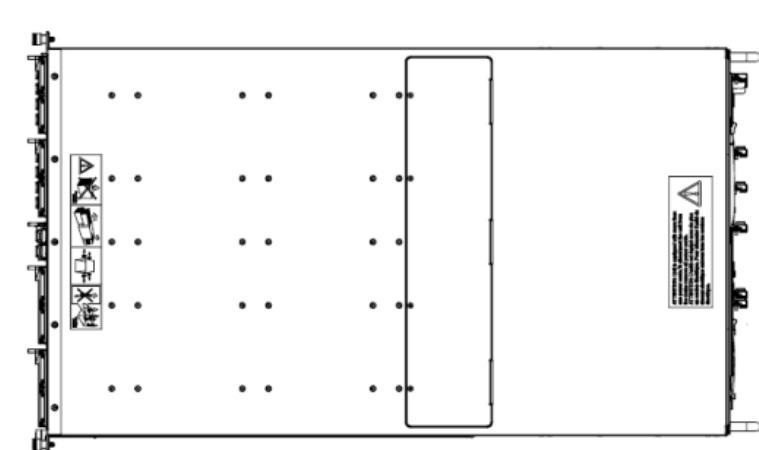
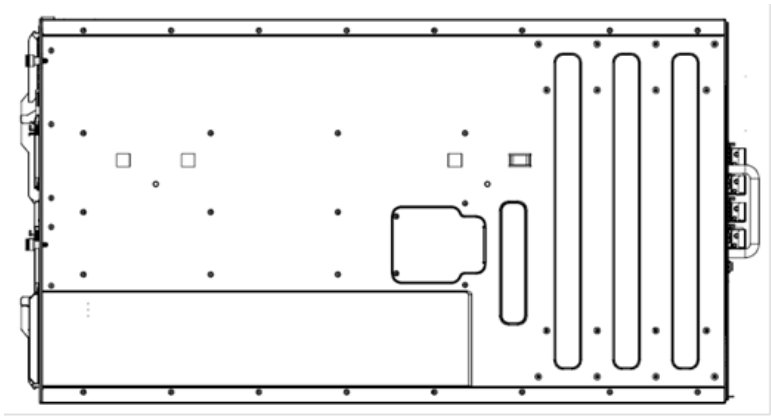

FIGURE 1.8 PRIMEQUEST 2800B right side view



1.2.2 External Overview of Device (PCI_Box)

Device External Overview (Front view, Rear view, Top view, Right side view) of PCI_Box is shown below.

FIGURE 1.9 Front View of PCI_Box

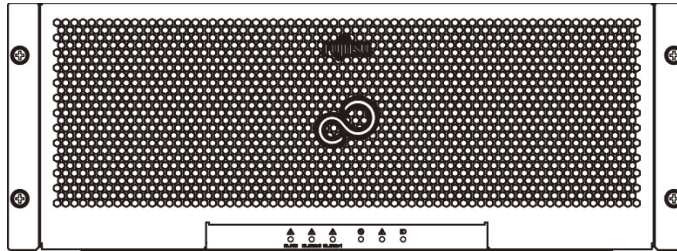

FIGURE 1.10 Rear View of PCI_Box

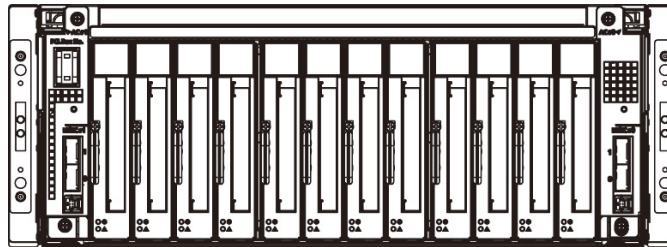

FIGURE 1.11 Top View of PCI_Box

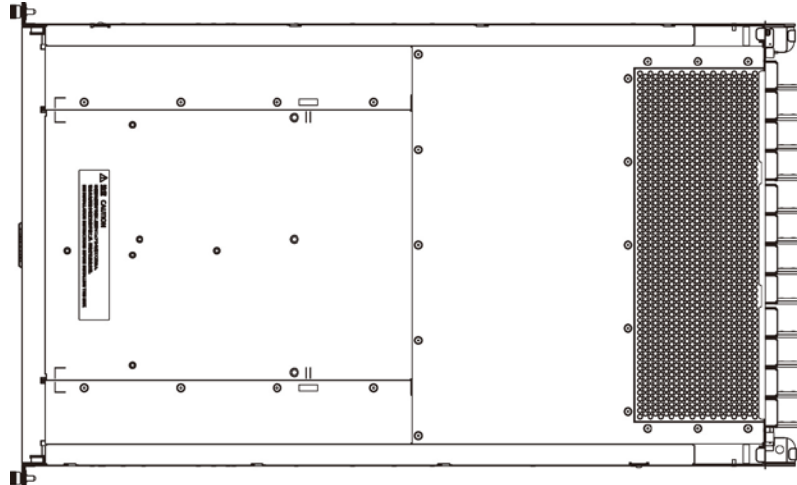
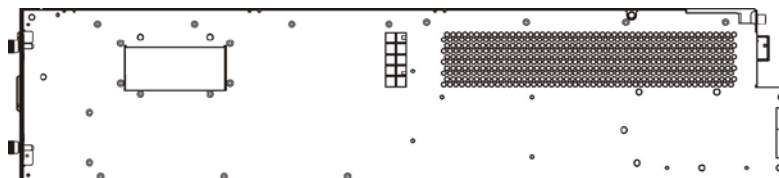

FIGURE 1.12 Right Side View of PCI_Box



1.3 Installation Specifications

This section explains installation specification of each equipment.

1.3.1 Installation specifications (PRIMEQUEST 2400E)

TABLE 1.2 Installation Specifications (PRIMEQUEST 2400E)

Item		Contents			
External Dimensions [mm(in.)]	Width	445(17.52)			
	Length(*1)	782(30.79)			
	Height	438(17.25) 10U			
Mass [kg(lb)] (*2)		128(282)			
Conditions for Air Conditioning	Maximum Calorific value [kJ/h(BTU/h)]	Input Voltage: 200V	Interruptible Power Supply(*13)	11,887(11,266)	
			High efficiency Power supply(*13)	11,805(11,189)	
	Displacement [m ³ /min(ft ³ /min)](*3)	Recommended Environmental temperature	Maximum	10(353)	
			Maximum	24(848)	
	Temperature and Humidity Conditions(*4)	Operating Time	Temperature[°C(°F)]	(*5)	
			Humidity[%RH]	20 to 80	
			Highest Wet bulb Temperature[°C(°F)]	29(84.2)	
		Down Time(*6)	Temperature[°C(°F)]	0 to 50(32 to 122)	
			Humidity[%RH]	8 to 80	
			Highest Wet bulb Temperature[°C(°F)]	29(84.2)	
	Noise[dB](*7,*8)		60		
	Acoustic power level[B](*8)		7.8		
	Permissible Vibration [m/s ² (gal)]	Operating Time(including waiting time)		4.0(400)(synthetic seismic wave)	
Down time(*9)		10.0(1000)(synthetic seismic wave)			
Permissible dust level[mg/m ³]		0.15			
Power Conditions	Input Voltage and Pulse number		200 to 240VAC±10% 100 to 120VAC±10% 1φ		
	Frequency and Fluctuation		50/60 Hz+2/-4%		
	Maximum Power Consumption /Apparent Power	Operating time	Input Voltage : 200 V	Interruptible Power Supply(*13)	4.17 kW/4.39 kVA
				High efficiency Power supply(*13)	4.04 kW/4.25 kVA
	Standby time	Input Voltage : 100 V	Interruptible Power Supply(*13)	4.42 kW/4.65 kVA	
			Standby time	0.079kW	
	Power Factor(*10)		0.95 or more		
	Inrush current[A][Rush time](*11)		20 or less		
Leak current[mA](*12)		6.8 or less at 200V 3.5 or less at 100V			

*1: Dimensions without protrusions (Dimensions including the front cover are 832mm(32.76in)).

- *2: Numeric value when each optional device is mounted for maximum number of options.
However, rail for mounting rack (5.7kg) and cable type are not included.
Mass as per the installation configuration can be calculated using formula as shown below.
Device Mass: $78 + (11.1 * A) + (2.5 * B) + (1.8 * C) + (3.3 * D)$ [kg]
A= Number of mounted SB (Minimum 1 to Maximum 2)
B=Number of mounted IOU (Minimum 1 to Maximum 4)
C=Number of mounted extended PSU (Minimum 2 to Maximum 4)
D=Number of mounted DU (Minimum 0 to Maximum 2)
- *3: If the device is overloaded or if abnormality is detected even though the recommended environmental temperature is used, the FAN rotates at high-speed.
- *4: Protect from condensation
- *5: Temperature conditions changes according to installation location above sea level.
For 0 to 1000 m (0 to 3281 ft) above sea level, temperature range at the time of installation: 5 to 35°C (41 to 95.0°F)
For 1000 to 1500 m (3281 to 4921 ft) above sea level, temperature range at the time of installation: 5 to 33°C (41 to 91.4°F)
For 1500 to 2000 m (4921 to 6562 ft) above sea level, temperature range at the time of installation: 5 to 31°C (41 to 87.8°F)
For 2000 to 3000 m (6562 to 9843 ft) above sea level, temperature range at the time of installation: 5 to 29°C (41 to 84.2°F)
Error of + 100m in the sea level settings of the location of installation is permissible.
- *6: Downtime is the condition in which the device is packed and maintained.
- *7: Level of noise which is actually heard varies as per the mounting condition of the position from where the noise is heard or the position of rack.
- *8: Level of noise and level of acoustic power changes according to the Hardware configuration, the processing load and the environmental temperature.
- *9: Downtime is the condition in which the device is installed. However, the power is switched off.
- *10: Value at the time of operations.
- *11: Value of 1 input cable
- *12: Value of 1 device
- *13: Interruptible power supply is the built-in PSU (80 PLUS SILVER supported), high efficiency power supply is the built-in PSU (80 PLUS PLATINUM supported)

1.3.2 Installation Specifications (PRIMEQUEST 2800E)

TABLE 1.3 Installation Specifications (PRIMEQUEST 2800E)

Items		Contents		
Dimensions [mm (in.)]	Width	445(17.52)		
	Depth (*1)	782(30.79)		
	Length	438(17.25) 10U		
Mass [kg (lb)] (*2)		150(331)		
Conditions for air conditioner	Max. calorific value [kJ/h (BTU/h)]	Interruptible power source		17,712(16,787)
		High efficiency power supply (*13)		17,388(16,480)
	Displacement [m ³ /min (ft ³ /min)] (*3)	Recommended environmental temperature		12(424)
		Max.		28(989)
	Temperature and Humidity conditions (*4)	At the time of operation	Temperature [°C (°F)]	(*5)
			Humidity [%RH]	20 to 80
			Max wet bulb temperature [°C (°F)]	29 (84.2)
		Downtime (*6)	Temperature [°C (°F)]	0 to 50 (32 to 122)
			Humidity [%RH]	8 to 80
			Max wet bulb temperature [°C (°F)]	29 (84.2)
Noise [dB] (*7, *8)		60		
Acoustic power level [B] (*8)		7.8		
Permissible Vibration [m/s ² (gal)]	At the time of operation (Including standby)		4.0 (400) (Composite seismic wave)	
	Downtime (*9)		10.0 (1000) (Composite seismic wave)	
Permissible dust level [mg/m ³]		0.15		
Power supply conditions	Input voltage and source resultant pulse number		200 to 240 VAC±10 % 1φ	
	Frequency and fluctuating Range		50/60 Hz + 2/-4%	
	Max power consumption / apparent power	At the time of operation	Interruptible power source (*13)	6.11 kW/6.43 kVA
			High efficiency power supply (*13)	5.92 kW/6.23 kVA
		Downtime		0.084 kW
	Power factor (*10)		0.95 or more	
	Inrush current [A] [Rush hours] (*11)		20 or less	
Leak current [mA] (*12)		6.9 or less		

*1: Dimensions without protrusions (832 mm(32.76in) including front cover)

*2: Numeric value when each optional device is mounted for maximum number of options.

However, rail for mounting rack (5.7kg) and cable type are not included.

Mass as per the installation configuration can be calculated using formula as shown below.

Device mass = 78 + (11.1 * A) + (2.5 * B) + (1.8 * C) + (3.3 * D) [kg]

A = Number of mounted SB (Minimum 1 to Maximum 4)

B= Number of mounted IOU (Minimum 1 to Maximum 4)

C= Number of mounted PSU (Minimum 2 to Maximum 6)

D= Number of mounted DU (Minimum 0 to Maximum 2)*3: There are cases when device is overloaded or when abnormality is detected, FAN rotates at high-speed even if recommended environmental temperature is used.

*4: Protect from condensation.

*5: Temperature condition changes according to the installation location above sea level.

For 0 to 1000 m (0 to 3281 ft) above sea level, temperature range at the time of installation: 5 to 35°C (41 to 95°F)

For 1000 to 1500 m (3281 to 4921 ft) above sea level, temperature range at the time of installation: 5 to 33°C (41 to 91.4°F)

For 1500 to 2000 m (4921 to 6562 ft) above sea level, temperature range at the time of installation: 5 to 31°C (41 to 87.8°F)

For 2000 to 3000 m (6562 to 9843 ft) above sea level, temperature range at the time of installation: 5 to 29°C (41 to 84.2°F)

Error of + 100m in the sea level settings of the location of installation is permissible.

- *6: Downtime is the condition in which the device is packed and maintained.
- *7: Level of noise which is actually heard varies as per the mounting condition of the position from where the noise is heard or the position of rack.
- *8: Level of noise and the level of acoustic power changes according to the Hardware configuration, the processing load and the environmental temperature.
- *9: Downtime is the condition in which the device is installed. However, the power is switched off.
- *10: Value at the time of operations.
- *11: Value of 1 input cable
- *12: Value of 1 device
- *13: Interruptible power supply is the built-in PSU (80 PLUS SILVER supported), high efficiency power supply is the built-in PSU (80 PLUS PLATINUM supported)

1.3.3 Installation Specifications (PRIMEQUEST 2800B)

TABLE 1.4 Installation Specifications (PRIMEQUEST 2800B)

Items		Contents		
Dimensions [mm (in.)]	Width	445(17.52)		
	Depth (*1)	782(30.79)		
	Length	438(17.25) 10U		
Mass [kg (lb)] (*2)		143(315)		
Conditions for air conditioner	Max. calorific value [kJ/h (BTU/h)]	Interruptible power source	16,992(16,105)	
		High efficiency power supply (*13)	16,740(15,866)	
	Displacement [m ³ /min (ft ³ /min)] (*3)	Recommended environmental temperature	12(424)	
		Max.	28(989)	
	Temperature and Humidity conditions (*4)	At the time of operation	Temperature [°C (°F)]	(*5)
			Humidity [%RH]	20 to 80
			Max wet bulb temperature [°C (°F)]	29 (84.2)
		Downtime (*6)	Temperature [°C (°F)]	0 to 50 (32 to 122)
			Humidity [%RH]	8 to 80
			Max wet bulb temperature [°C (°F)]	29 (84.2)
	Noise [dB] (*7, *8)		60	
	Acoustic power level [B] (*8)		7.8	
Permissible Vibration [m/s ² (gal)]	At the time of operation (Including standby)	4.0 (400) (Composite seismic wave)		
	Downtime (*9)	10.0 (1000) (Composite seismic wave)		
Permissible dust level [mg/m ³]		0.15		
Power supply conditions	Input voltage and source resultant pulse number		200 to 240 VAC±10 % 1φ	
	Frequency and fluctuating Range		50/60 Hz + 2/-4%	
	Max power consumption / apparent power	At the time of operation	Interruptible power source (*13)	6.00 kW/6.32 kVA
			High efficiency power supply (*13)	5.81 kW/6.12 kVA
		Downtime		0.084 kW
	Power factor (*10)		0.95 or more	
	Inrush current [A] [Rush hours] (*11)		20 or less	
	Leak current [mA] (*12)		6.9 or less	

*1: Dimensions without protrusions

*2: Numeric value when each optional device is mounted for maximum number of options.

However, rail for mounting rack (5.7kg) and cable type are not included.

Mass as per the installation configuration can be calculated using formula as shown below.

Device mass = 77 + (9.6 * A) + (2.5 * B) + (1.8 * C) + (3.3 * D) [kg]

A = Number of mounted SB (Minimum 1 to Maximum 4)

B = Number of mounted IOU (Minimum 1 to Maximum 4)

C = Number of mounted PSU (Minimum 2 to Maximum 6)

D = Number of mounted DU (Minimum 0 to Maximum 2)

*3: There are cases when device is overloaded or when abnormality is detected, FAN rotates at high-speed even if recommended environmental temperature is used.

*4: Protect from condensation.

*5: Temperature condition changes according to the installation location above sea level.

For 0 to 1000 m (0 to 3281 ft) above sea level, temperature range at the time of installation: 5 to 35°C (41 to 95°F)

For 1000 to 1500 m (3281 to 4921 ft) above sea level, temperature range at the time of installation: 5 to 33°C (41 to 91.4°F)

For 1500 to 2000 m (4921 to 6562 ft) above sea level, temperature range at the time of installation: 5 to 31°C (41 to 87.8°F)

For 2000 to 3000 m (6562 to 9843 ft) above sea level, temperature range at the time of installation: 5 to 29°C (41 to 84.2°F)

Error of + 100m in the sea level settings of the location of installation is permissible.

*6: Downtime is the condition in which the device is packed and maintained.

*7: Level of noise which is actually heard varies as per the mounting condition of the position from where the noise is heard or the position of rack.

*8: Level of noise and the level of acoustic power changes according to the Hardware configuration, the processing load and the environmental temperature.

*9: Downtime is the condition in which the device is installed. However, the power is switched off.

*10: Value at the time of operations.

*11: Value of 1 input cable

*12: Value of 1 device

*13: Interruptible power supply is the built-in PSU (80 PLUS SILVER supported), high efficiency power supply is the built-in PSU (80 PLUS PLATINUM supported)

1.3.4 Installation Specifications (PCI_Box)

TABLE 1.5 Installation Specifications (PCI_Box)

Item		Contents		
Dimensions [mm (in)]	Width	482 (18.98)		
	Depth	740 (29.13)		
	Length	175 (6.89) 4U		
Mass [kg (lb)] (*2)		35 (77)		
Conditions for air conditioner	Max. calorific value [kJ/h (BTU/h)]		1656 (1570)	
	Displacement [m ³ /min (ft ³ /min)] (*3)	FAN low speed (Low)	3 (106)	
		FAN medium speed (Normal)	4 (141)	
		FAN high speed (High)	5 (177)	
	Temperature and Humidity condition (*4)	At time of operation	Temperature [°C (°F)]	(*5)
			Humidity [%RH]	20 to 80
			Max wet bulb temperature [°C (°F)]	29 (84.2)
		Downtime (*6)	Temperature [°C (°F)]	0 to 50 (32 to 122)
			Humidity [%RH]	8 to 80
			Max wet bulb temperature [°C (°F)]	29 (84.2)
	Noise [dB] (*7, *8)		(Included in installation)	
	Acoustic power level [B] (*8)		(Included in installation)	
	Permissible Vibration [m/s ² (gal)]	At the time of operation (Including standby)		4.0 (400) (Composite seismic wave)
Downtime (*9)		10.0 (1000) (Composite seismic wave)		
Permissible dust level [mg/m ³]		0.15		
Power Supply conditions	Input voltage and source resultant pulse number		200 to 240 VAC±10 % 100 to 120 VAC±10 % 1φ	
	Frequency and fluctuating Range		50/60 Hz + 2/-4%	
	Max power consumption / apparent power	At the time of operation	Input voltage: 200 V	450W/475 VA
			Input voltage: 100 V	460W/485 VA
		Downtime	Input voltage: 200 V	10W/40VA
			Input voltage: 100 V	10W/35 VA
	Power factor (*10)		More than equal to 0.95	
	Inrush current [A] [Rush hours] (*11)		Less than or equal to 25	
Leak current [mA] (*12)		Less than or equal to 3.5		

*1: Dimensions without protrusions.

*2: Numeric value when each optional device is mounted for maximum number of options.

*3: If the device is overloaded or if abnormality is detected even though the recommended environmental temperature is used, the FAN rotates at high-speed.

*4: Protect from condensation.

*5: Temperature condition changes according to the installation location above sea level.

For 0 to 1000 m (0 to 3281 ft) above sea level, temperature range at the time of installation: 5 to 35°C (41 to 95°F)

For 1000 to 1500 m (3281 to 4921 ft) above sea level, temperature range at the time of installation: 5 to 33°C (41 to 91.4°F)

For 1500 to 2000 m (4921 to 6562 ft) above sea level, temperature range at the time of installation: 5 to 31°C (41 to 87.8°F)

For 2000 to 3000 m (6562 to 9843 ft) above sea level, temperature range at the time of installation: 5 to 29°C (41 to 84.2°F)

Error of + 100m in the sea level settings of the location of installation is permissible.

*6: Downtime is the condition in which the device is packed and maintained.

- *7: Level of noise which is actually heard varies as per the mounting condition of the position from where the noise is heard or the position of rack.
- *8: Level of noise and level of acoustic power changes according to the environmental temperature
- *9: Downtime is the condition in which the device is installed. However, the power is switched off.
- *10: Value at the time of operations.
- *11: Value of 1 input cable
- *12: Value of 1 device

1.4 Installation Area

Here, the installation area and the service area when the PRIMEQUEST 2000 series or the PCI_Box is installed on 19-inch made by Fujitsu rack are explained.
 The installation area and the service area differ according to the installed 19-inch rack.
 For details on the 19-inch racks, contact the distributor where you purchased your product, or your sales representative.

FIGURE 1.13 Service Area at the time of installing 19 inch rack model

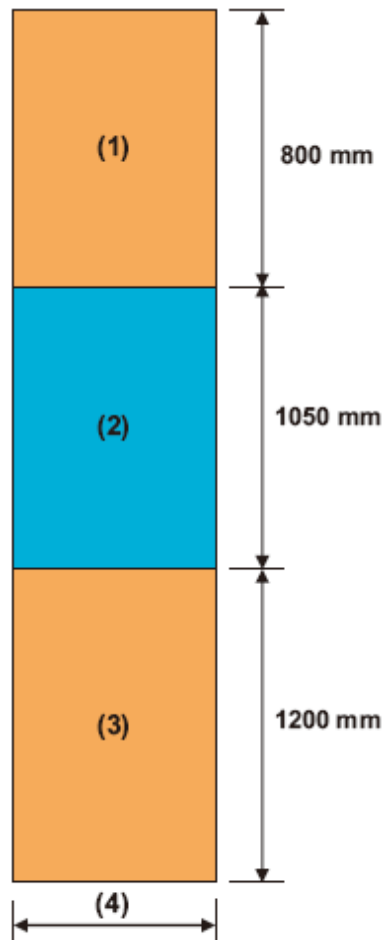

Number	Description		
(1)	Rear side maintenance area		
(2)	Rack		
(3)	Front side maintenance area		
(4)	Rack width	Model 2724/2737/2742, PCRM1 724S/742S/724A/742A	700 mm
		Model 2616/2624/2642, PCRM1 616S/624S/642S	600 mm

1.5 Flow of Cooling Air and Exhaust Air of Installation

Here, the flow of the cooling air and the exhaust of each device are explained.

Note

Flow of cooling air and exhaust air should be considered while studying the installation of a device. If device is installed without considering them, it may get affected by inhaling the exhaust air from the other device. Especially, the device detecting the intake air temperature may raise alarm indicating abnormality.

1.5.1 Flow of Cooling Air and Exhaust Air (Main Cabinet)

FIGURE 1.14 Flow of Cooling Air and Exhaust Air (Main Cabinet)

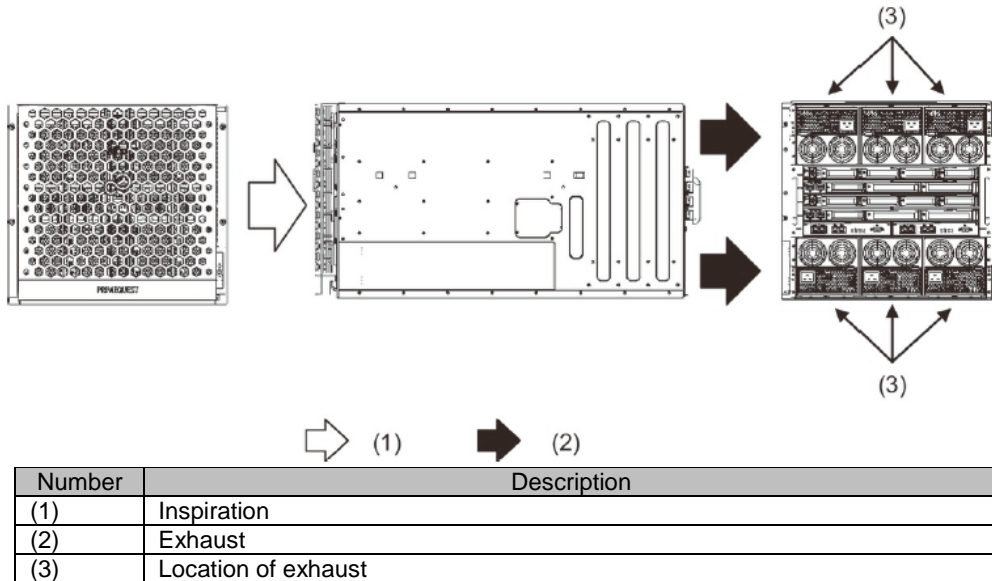

1.5.2 Flow of Cooling Air and Exhaust (PCI_Box)

FIGURE 1.15 Flow of Cooling Air and Exhaust (PCI_Box)

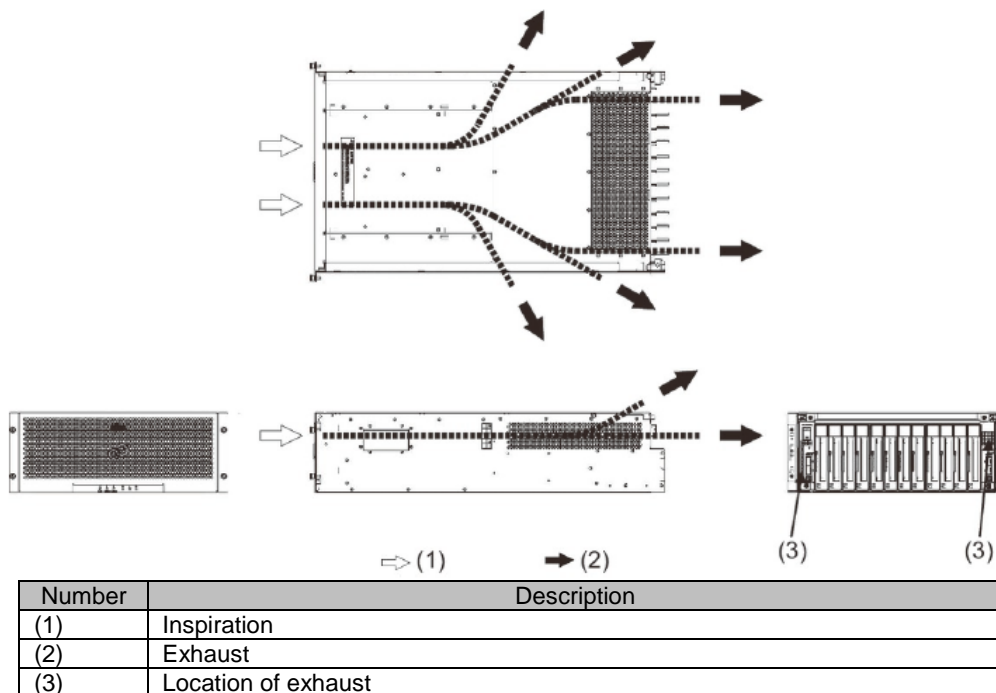

1.6 Installation Environment

This section describes the installation environment of the base cabinet and PCI_Box.

1.6.1 Dust

Suspended Particles

Suspended particles in a computer room should not exceed $0.15\text{mg}/\text{m}^3$. A computer is designed in such a way that it withstands the suspended particles. This value is permissible in an ordinary office. However, this value can be maintained in the ordinary computer room if there is less outdoor air infiltration having suspended particles like dust and if there is no smoke of cigarettes.

Dust Removal

The suspended particles like dust are collected in the filter of an air conditioner. The dust should be removed from the computer room by cleaning floor surfaces and underfloor periodically. Cleaning is necessary in the following cases.

- When the computer room is ready, and before bringing in the computers
- At the time of repairing the computer room
- At the time of shifting the computers and re-arranging the devices

1.6.2 Corrosive Gas

Corrosive gas and salty wind cause corrosion, malfunctioning, and damage of the device, and reduce life of the device remarkably.

Corrosive gas should be removed by providing suitable air cleaning equipment. In addition, positive clear air pressure in the room prevents an entering of the corrosive gas from the outside. The chemical factory area, thermal water/ volcanic zone etc. are considered as a source of corrosive gas.

TABLE 1.6 Permissible Level of Corrosive Gas

Name of gas	Permissible level
Hydrogen sulfide (H_2S)	7.1ppb or less
Sulfur dioxide (Sulfur oxide)(SO_2)	37ppb or less
Hydrogen chloride (HCL)	6.6ppb or less
Chlorine (Cl_2)	3.4ppb or less
Hydrogen fluoride (HF)	3.6ppb or less
Nitrogen dioxide (Nitrogen oxides)(NO_2)	52ppb or less
Ammonia(NH_3)	420ppb or less
Ozone(O_3)	5ppb or less
Fluid vapor	$0.2\text{mg}/\text{m}^3$ or less

1.6.3 Sea Water (Salt Damage)

A large number of sea-salt particles are suspended in air by the salty wind near the sea-coast. If the sea-salt particles remain in the computer, moisture and chemically condensed substances cause insulation failure, and corrosion degradation of the components. Therefore, the computer should be installed at a place which is far from the sea-coast.

Installation standards to prevent damage due to sea salt particles are shown below.

Standards: The computer should be installed at a place which is at least 0.5km away from the sea-coast (Excluding the case having air-conditioner which prevents an entering of air from outside)

1.7 Safety Measures

For details on safety measures, see "Chapter 8 Safety Measures" of "*SPARC M10 System/ SPARC Enterprise/PRIMEQUEST Common Installation Planning Manual*" (C120-H007EN).

CHAPTER 2 Connected Information

This section describes the connection summary of cable and cable used in PRIMEQUEST 2000 series.

2.1 Connection summary

This section shows the Device connection summary of PRIMEQUEST 2000 series.

FIGURE 2.1 Summary of Device Connection

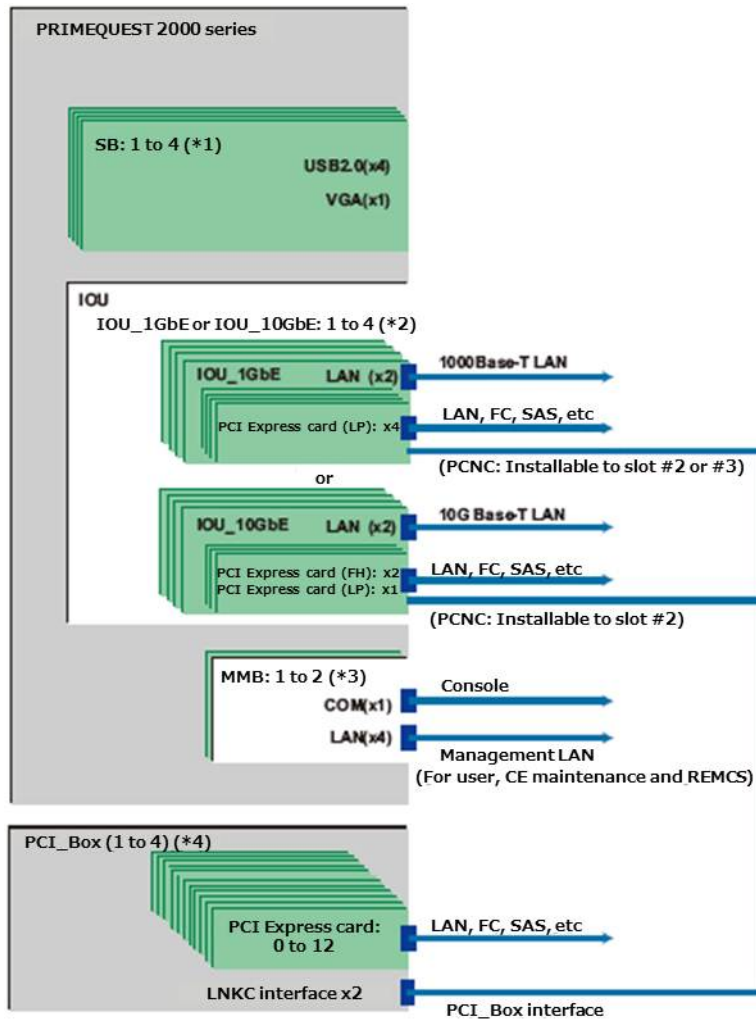

TABLE 2.1 Notes for Device connection

Number	Configured part	Description	
*1	SB	PRIMEQUEST 2400E	Maximum 2 units can be mounted
		PRIMEQUEST 2800E/2800B	Maximum 4 units can be mounted
*2	IOU	PRIMEQUEST 2400E/2800E/2800B	Maximum 4 units of IOU_1GbE or IOU_10GbE can be mounted.
*3	MMB	PRIMEQUEST 2400E/2800E	Maximum 2 units can be mounted
		PRIMEQUEST 2800B	Maximum 1 unit can be mounted
*4	PCI_Box	PRIMEQUEST 2400E/2800E	Maximum 4 units can be mounted
		PRIMEQUEST 2800B	No PCI_Box can be mounted.

2.2 Connection of signal cable

This section describes the notes for connection of signal cable, cable list and cable procure.

2.2.1 Basic interface and peripheral

For details of basic interface of PRIMEQUEST 2000 series and cable connection of peripheral, see “PRIMEQUEST 2000 series system mounting”

2.2.2 Details of external interface connection

Mounting position of external interface connecting part of PRIMEQUEST 2000 series is shown in the section below. When calculating the length of the connection cable, you should take account into the mounting position.

External interface connection (PRIMEQUEST 2400E in base cabinet)

External interface connection figure of PRIMEQUEST 2400E in base cabinet is shown in the section below. The figure below is uncovered front surface (face). The front cover must be attached in normal operation.

FIGURE 2.2 External interface connection figure of (PRIMEQUEST 2400E (Front surface))

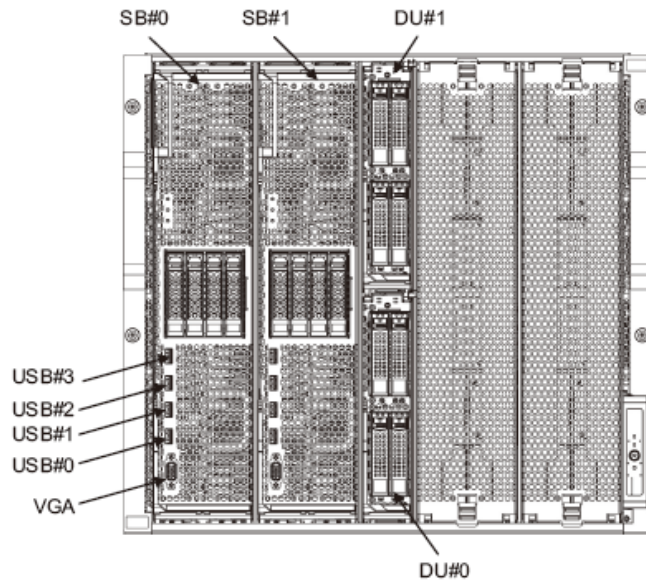
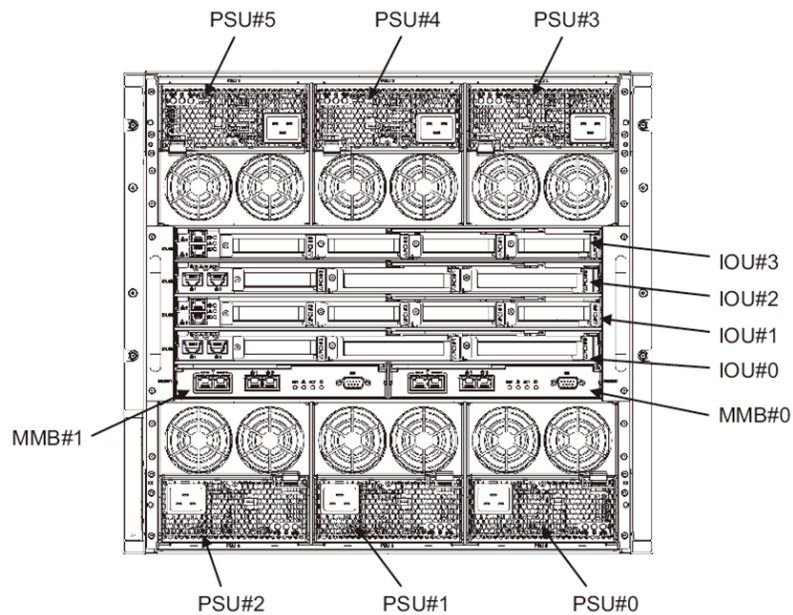

FIGURE 2.3 External interface connection figure of (PRIMEQUEST 2400E (Back surface))



External interface connection (PRIMEQUEST 2800E in base cabinet)

External interface connection figure of PRIMEQUEST 2800E in base cabinet is shown in the section below. This figure is uncovered front surface (face). The front cover must be attached in normal operation.

FIGURE 2.4 External interface connection figure of (PRIMEQUEST 2800E (Front surface))

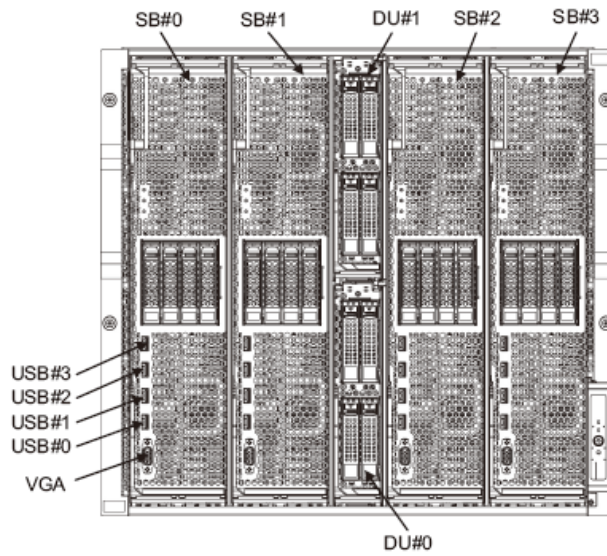
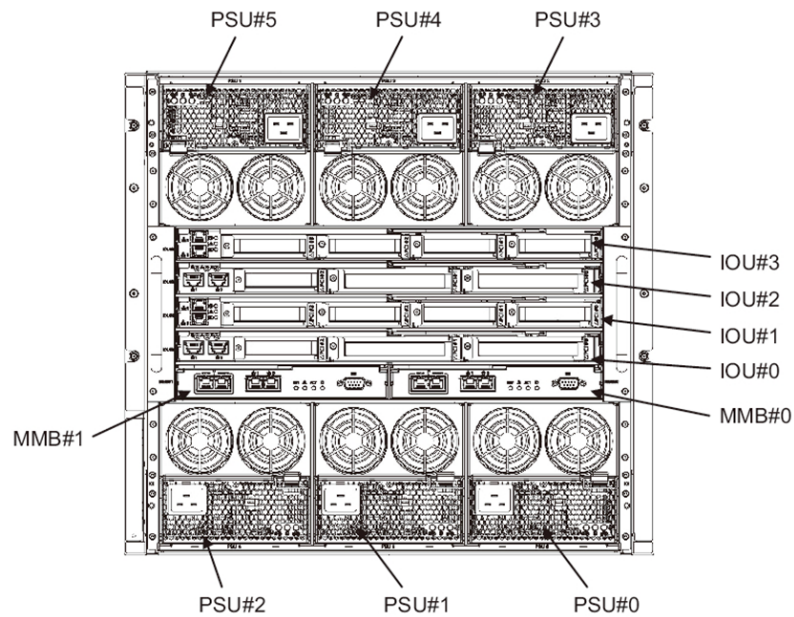

FIGURE 2.5 External interface connection figure of (PRIMEQUEST 2800E (Back surface))



External interface connection (PRIMEQUEST 2800B in base cabinet)

External interface connection figure of PRIMEQUEST 2800B in base cabinet is shown in the section below.
This figure is uncovered front surface (face).
The front cover must be attached in normal operation.

FIGURE 2.6 External interface connection figure of (PRIMEQUEST 2800B (Front surface))

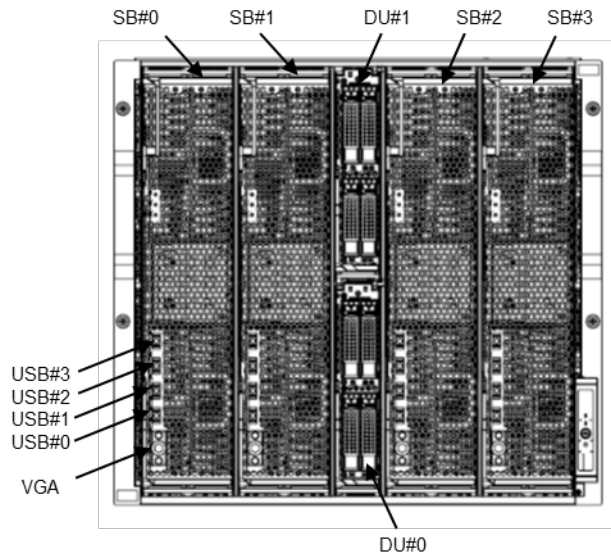
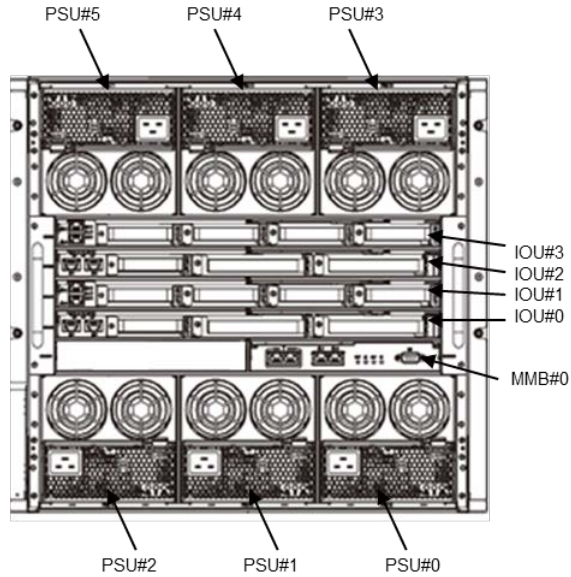
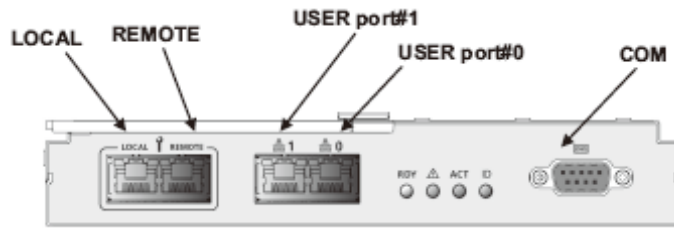

FIGURE 2.7 External interface connection figure of (PRIMEQUEST 2800B (Back surface))



Details of external interface (MMB)

FIGURE 2.8 Details of external interface (MMB)



Details of external interface (IOU_1GbE/IOU_10GbE)

FIGURE 2.9 Details of external interface (IOU_1GbE)

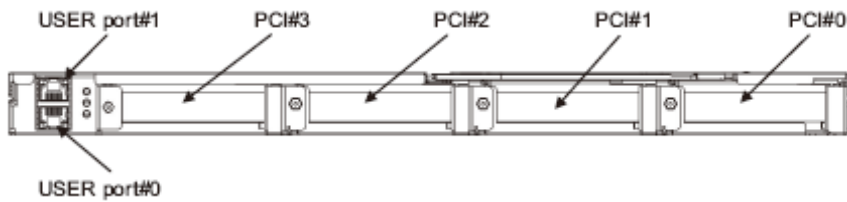
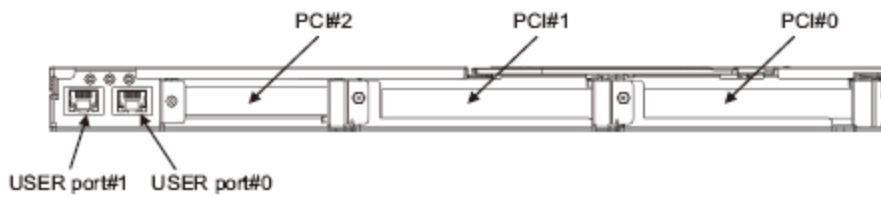
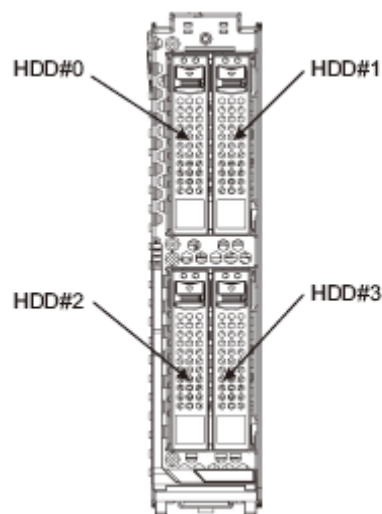

FIGURE 2.10 Details of external interface (IOU_10GbE)



Details of external interface (DU)

FIGURE 2.11 Details of external interface (DU)



Details of external interface (PCI_Box)

FIGURE 2.12 Details of external interface (PCI_Box)

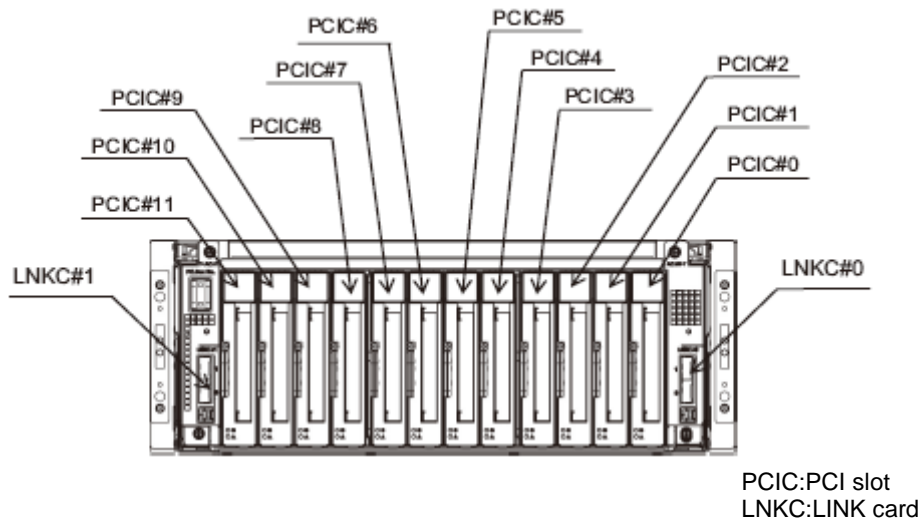

2.3 Power cable connection

Input power system of PRIMEQUEST 2000series and PCI_Box is described in this section.

2.3.1 Power Supply Cable Connection (PRIMEQUEST 2400E)

Input power system diagram of PRIMEQUEST 2400E is as shown below.

100 V Standard Power Feed Configuration (Single power feed, no Redundant Power Feed)

It is necessary to arrange three PSUs, three FANUs and three power supply cables (100 V NEMA 5-15P) for 100V standard power feed configuration (single power feed, no redundant power feed).

FIGURE 2.13 100V Standard Power Feed Configuration (Single power feed, no Redundant Power Feed)

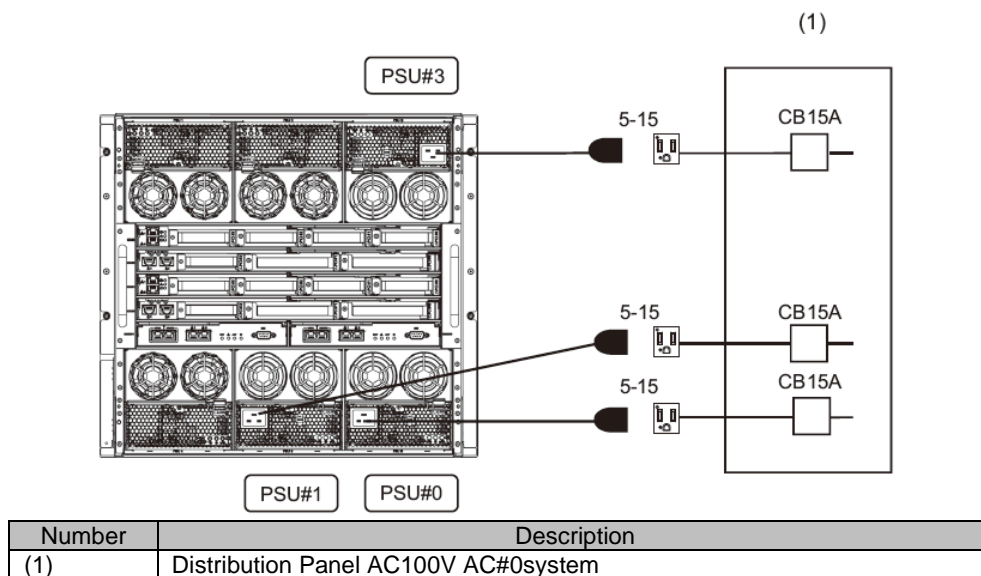

100 V Redundant Power Feed Configuration (Single power feed, Redundant Power Feed)

It is necessary to arrange four PSUs, two FANUs and four power supply cables (100 V NEMA 5-15P) for 100V redundant power feed configuration (single power feed, redundant power feed).

FIGURE 2.14 100V Redundant Power Feed Configuration (Single power feed, Redundant Power Feed)

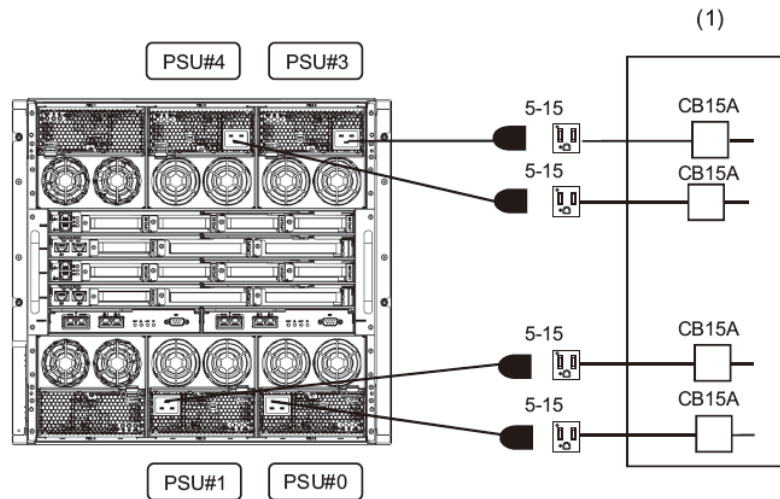

Number	Description
(1)	Distribution Panel AC100V AC#0system

Standard Configuration of 200 V (single power feed, no redundant power feed) with Power Distribution Box Connection

It is necessary to arrange two PSUs, four FANUs, two power cables (200 V IEC60320 C20) and two power distribution boxes (200 V IEC60320 C19x3type) for standard configuration of 200 V (single power feed, no redundant power supply).

When the power distribution box is used, it is necessary to secure the breaker characteristic of distribution panel. See “2.6 Cutoff Characteristics of Distribution Panel (At the time of connecting power distribution box).”

FIGURE 2.15 Standard Configuration of 200 V (single power feed, no redundant power feed) with Power Distribution Box Connection

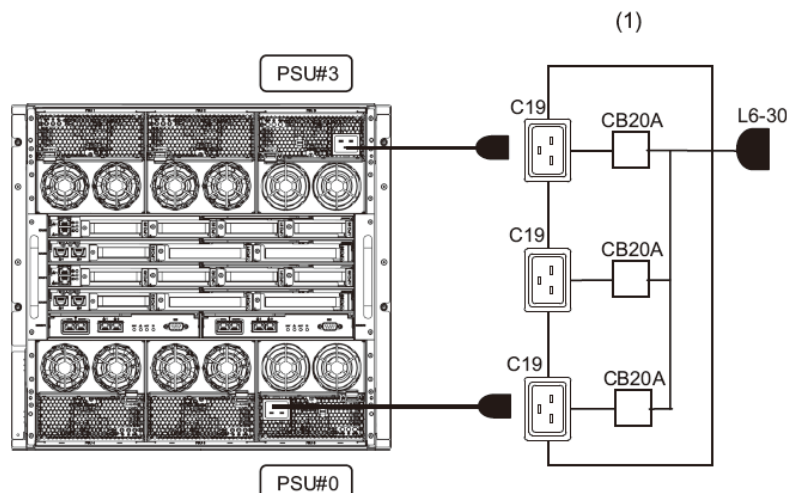

Number	Description
(1)	Power distribution box (200V C 19 × 3 type)

200 V Redundant Power Feed Configuration (with single power feed, redundant power feed) with Power Distribution Box Connection

It is necessary to arrange three PSUs, three FANUs, three Power cables (200 V IEC60320 C20) and two power distribution box (200 V IEC60320 C19×3type) for of 200 V Redundant Power Feed Configuration (single power feed, redundant power feed).

When the power distribution box is used, it is necessary to secure the breaker characteristic of distribution panel. See “2.6 Cutoff Characteristics of Distribution Panel (At the time of connecting power distribution box).”

FIGURE 2.16 200 V Redundant Power Feed Configuration (single power feed, redundant power feed) with Power Distribution Box Connection

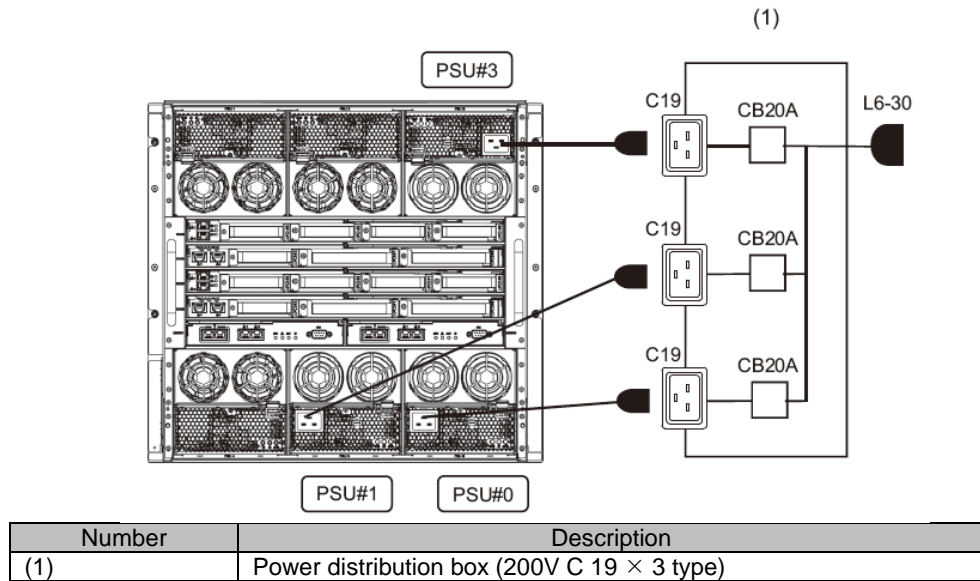

200V Dual Power Feed Configuration with Power Distribution Box Connection

It is necessary to arrange four PSUs, two FANUs, four power cables (200 V IEC60320 C20) and two power distribution box (200 V IEC60320 C19×3type) for 200 V dual power feed configuration for Japan and Overseas.

When the power distribution box is used, it is necessary to secure the breaker characteristic of distribution panel. See “2.6 Cutoff Characteristics of Distribution Panel (At the time of connecting power distribution box).”

FIGURE 2.17 200 V Dual Power Feed Configuration with Power Distribution Box Connection

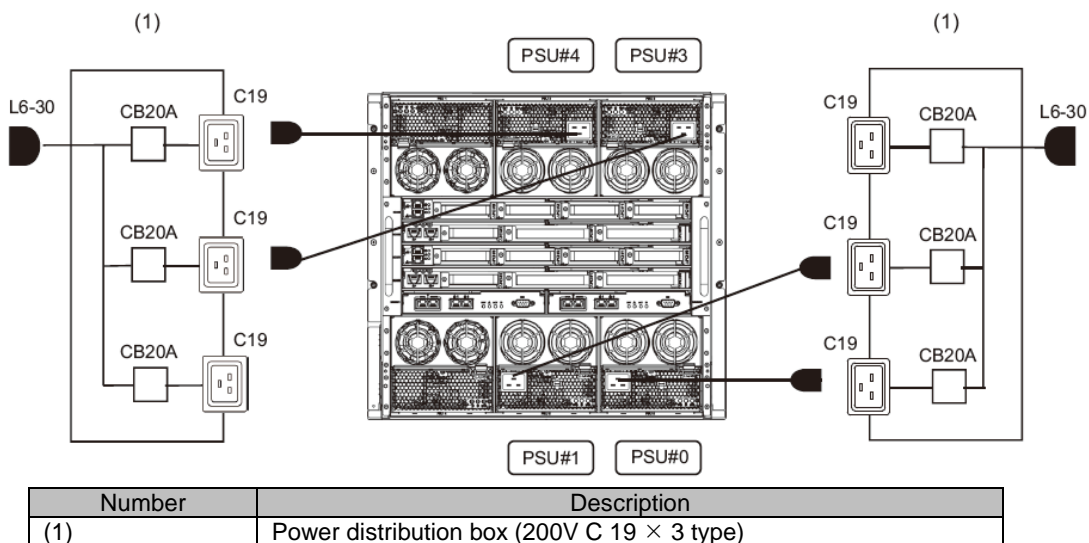

2.3.2 Power Cables Connections (PRIMEQUEST 2800E/2800B)

This section shows the figure of input power of PRIMEQUEST 2800E/2800B.

Standard Configuration of 200 V (Single power feed and no Redundant Power Feed) with Power Distribution Box Connection

It is necessary to arrange three PSUs, three FANUs, three power cables (200 V IEC60320 C20) and two power distribution box (200 V IEC60320 C19×3type) for 200 V standard configuration.

When the power distribution box is used, it is necessary to secure the breaker characteristic of distribution panel. See “2.6 Cutoff Characteristics of Distribution Panel (At the time of connecting power distribution box).”

FIGURE 2.18 200V Standard Configuration (single power feed and no redundant power feed) with Power Distribution Box Connection

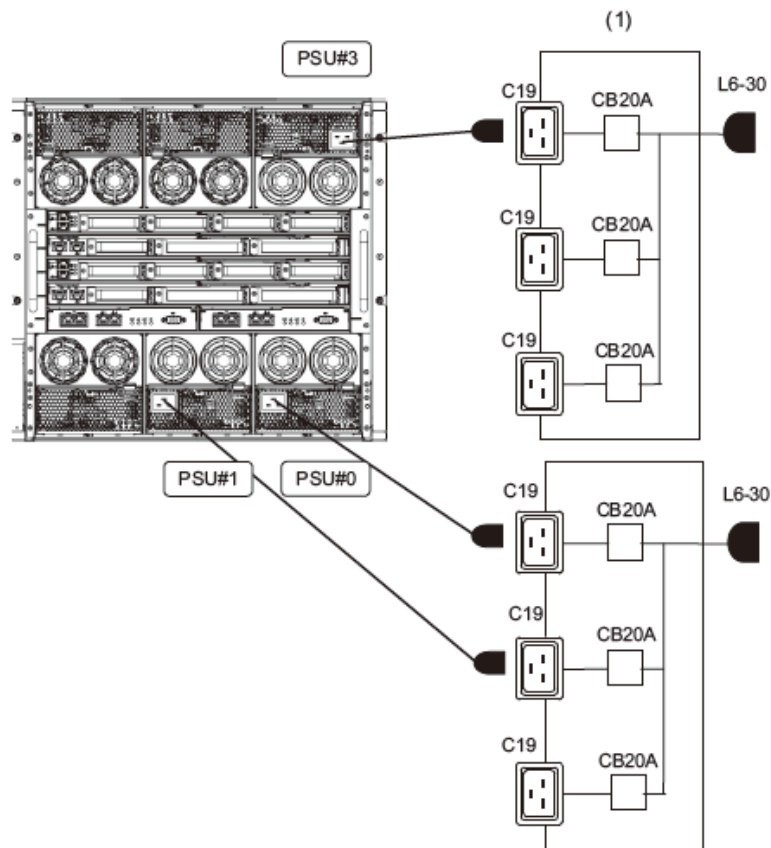

Number	Description
(1)	Power distribution box (200V C 19 × 3 type)

200 V Redundant Power Feed Configuration (single power feed, redundant power feed) with Power Distribution Box Connection

It is necessary to arrange four PSUs, two FANUs, four Power cables (200 V IEC60320 C20) and two power distribution boxes (200 V IEC60320 C19×3type) for 200 V Redundant Power Feed configuration (with single power feed, redundant power feed).

When the power distribution box is used, it is necessary to secure the breaker characteristic of distribution panel. See “2.6 Cutoff Characteristics of Distribution Panel (At the time of connecting power distribution box).”

FIGURE 2.19 200 V Redundant Power Feed Configuration (single power feed, redundant power feed) with Power Distribution Box Connection

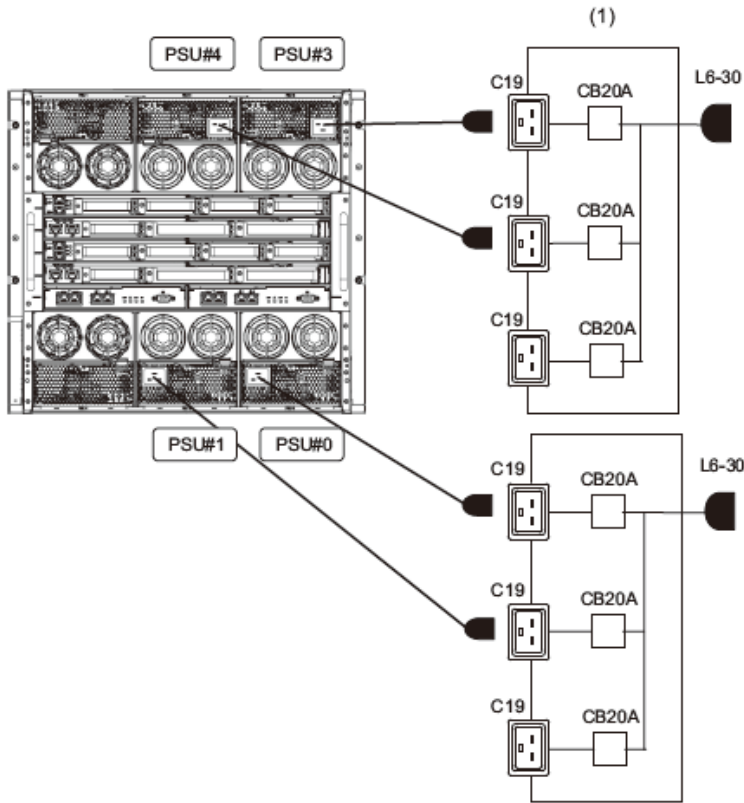

Number	Description
(1)	Power distribution box (200V C 19 × 3 type)

200 V Dual Power Feed Configuration with Power Distribution Box Connection

It is necessary to arrange six PSUs, six power cables (200 V IEC60320 C20) and four power distribution boxes (200 V IEC60320 C19×3type) for 200 V dual power feed configuration. When the power distribution box is used, it is necessary to secure the breaker characteristic of distribution panel. See “2.6 Cutoff Characteristics of Distribution Panel (At the time of connecting power distribution box).”

FIGURE 2.20 200 V Dual Power Feed Configuration with Power Distribution Box Connection

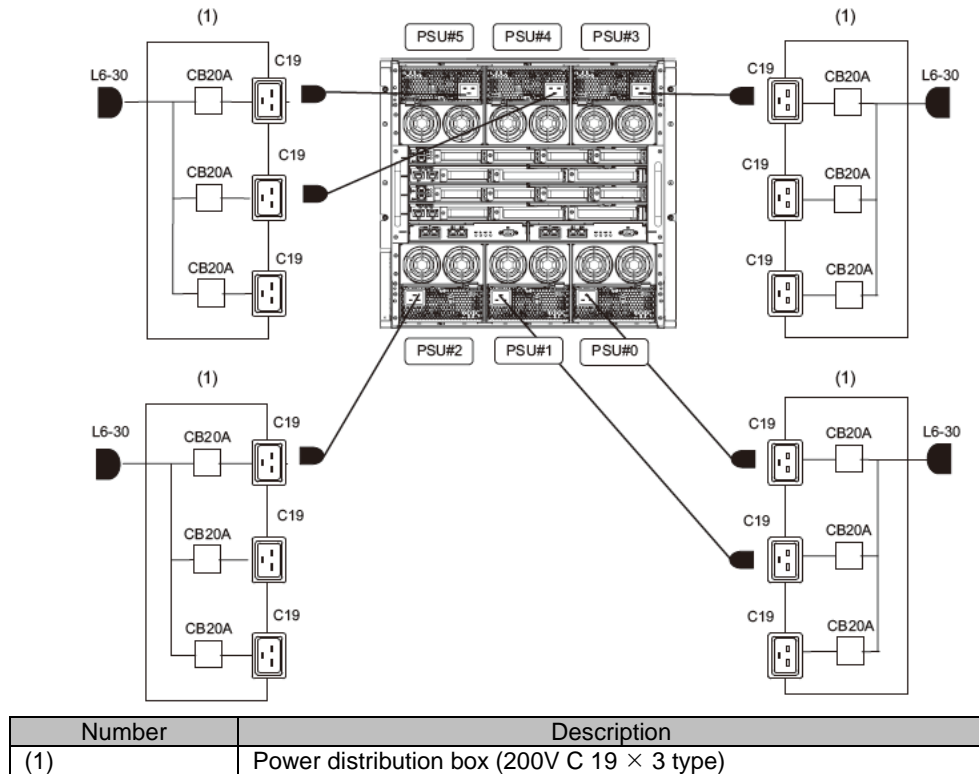

2.3.3 Power Cable Connections (PCI_Box)

This section shows the figure of input power of PCI_Box.

Remarks

While configuring redundant power feed and dual power feed in this device, configure the same power feed to PCI_Box.

100 V Configuration (single power feed, no redundant power feed)

It is necessary to arrange PSU and power cable (100 V NEMA 5-15P) for 100 V configuration (Single power feed, no redundant power feed).

FIGURE 2.21 100 V Configuration (Single power feed, no Redundant power feed)

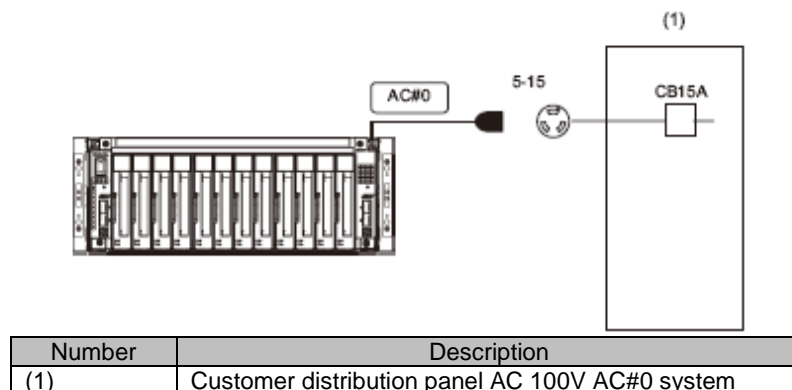

100 V Redundant Power Feed Configuration (single power feed, redundant power feed)

It is necessary to arrange two PSUs and two power cables (100 V NEMA 5-15P) for 100 V redundant power feed configuration (single power feed, redundant power feed).

FIGURE 2.22 100 V Redundant power feed configuration (Single power feed, redundant power feed)

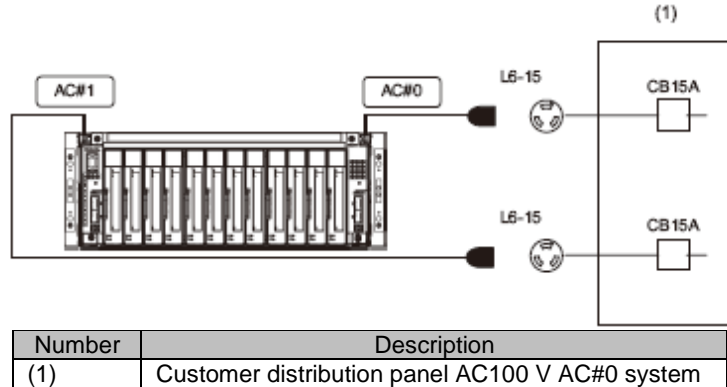

200 V Standard configuration (single power feed, no redundant power feed) with power distribution box connection

It is necessary to arrange PSU, power cable (200 V IEC 60320 C14) and power distribution box (200 V IEC60320 C13×4 types) for 200 V Standard configuration (single power feed, no redundant power feed).

FIGURE 2.23 200V Standard configuration (single power feed, no redundant power feed) power distribution box connection

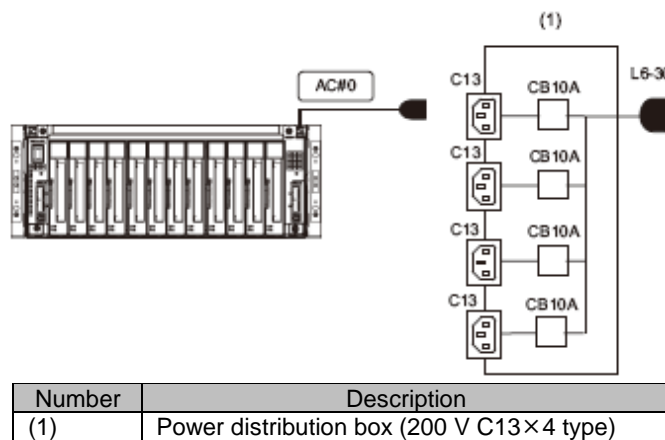

200 V Redundant power feed configuration (single power feed, redundant power feed) power distribution box connection

It is necessary to arrange two PSUs, two power cables (200 V IEC60320 C14) and power distribution box (200 V IEC60320 C13x4 type) for 200 V redundant power feed configuration (single power feed, redundant power supply).

FIGURE 2.24 200 V Redundant Power Feed Configuration (Single power feed, Redundant Power Feed) Power Distribution Box Connection

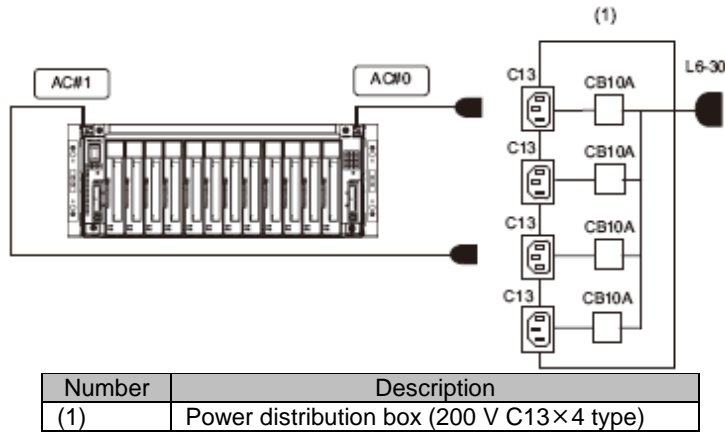

200 V Dual Power Feed Configuration with Power Distribution Box Connection

It is necessary to arrange two PSUs, two power cables (200 V IEC60320 C14) and two power distribution boxes (200 V IEC60320 C13x4 type) for 200 V dual power feed configuration.

FIGURE 2.25 200 V Dual Power Feed Configuration with Power Distribution Box Connection

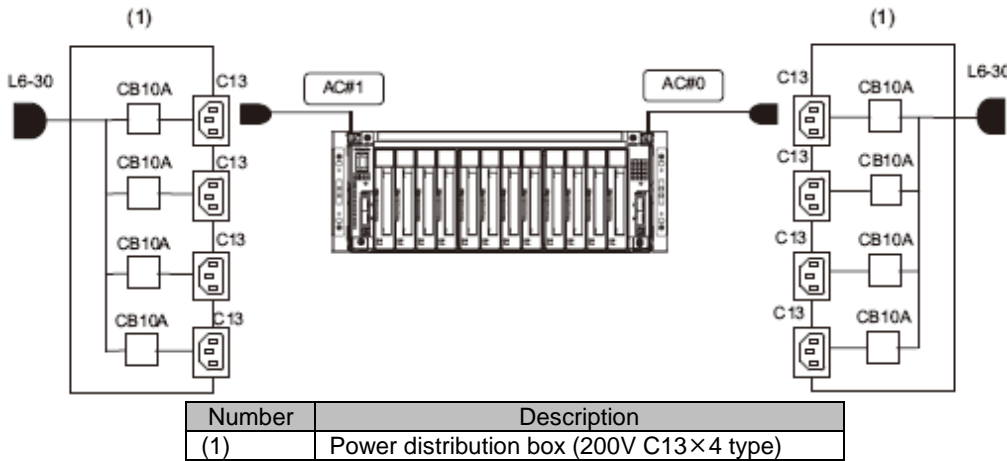

2.4 Connection Specifications of Input Power

This section describes the connection specifications of Input power of the base cabinet or PCI_Box of PRIMEQUEST 2000 series.

2.4.1 Input Power Connection Specifications (Base Cabinet)

Following table shows the input power connection specifications of the main unit.

TABLE 2.2 Power Cable Specifications (Base Cabinet)

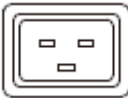
Destination	Plug format	Remarks	
100 V	Parallel 2-pole plug with earthing-contact "NEMA standard 5-15P"	Connection at wall-mount power distribution	
		Recipient power distribution format 	Power distribution "NEMA standard 5-15R" for parallel 2-pole plug with earthing - contact (125V 15A)
200 V	IEC60320-C20 type	Connection at power distribution box	
		Recipient outlet format 	IEC60320-C19type



Remarks

- Power cable supplied with the device and power cord supplied with the option part, are used for the power cable which is connected to the device. However, the supplied power cable is not used for the other products.
- Power distribution box which is suitable to recipient power distribution format is used

2.4.2 Input Power Supply Connection Specifications (PCI_Box)

Following table shows the input power supply connection specifications of PCI_Box.

TABLE 2.3 Power Cable Specification (PCI_Box)

Destination	Plug format	Remarks	
100V	Parallel 2-pole plug with earthing-contact "NEMA standard 5-15P"	Connection at wall-mount power distribution	
		Connection at power distribution box 	Power distribution "NEMA standard 5-15R" for parallel 2-pole plug with earthing- contact (125V 15A)
200V	IEC60320-C14 type	Connection at power distribution box	
		Recipient outlet format 	IEC60320-C13 type



Remarks

- Power cable supplied with the device and power cord supplied with the option part, are used for the power cable which is connected to the device. However, the supplied power cable is not used for the other products.
- Power distribution box which is suitable to recipient power distribution format is used

2.4.3 Power Distribution Box and Distribution Panel

Following table shows the power supply cable specifications of power distribution box and distribution panel.

TABLE 2.4 Power Supply Cable Specifications of Power Distribution Box and Distribution Panel

Destination	Plug format	Remarks	
200V for countries other than Japan	NEMAL6-30P	Recipient power distribution format 	NEMA L6-30R (30A-220V)
200V for Brazil	IEC60309-32A	Recipient power distribution format 	IEC60309-32A (32A-250V)

Remarks

Power cable supplied with the device and power cord supplied with the option part, are not used for the power cable which is connected to the device. However, the supplied power cable is not used for the other products.

2.5 Free Access Underfloor Connection of Power Cable

If the height of underfloor is less than 300mm (11.8 in.), the power distribution is set to sideways.

FIGURE 2.26 When Underfloor Height is less than 300mm (11.8 in)

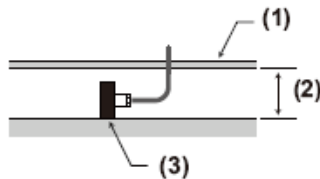

Number	Description
(1)	Free access floor
(2)	Less than 300mm (11.8 in)
(3)	Recipient power distribution

The connector format and cable bend radius of power cable are considered at the time of connecting the power cable of power distribution box (or base cabinet, PCI_Box) under the free access floor. It is recommended that the under floor height is 300 mm (11.8 in) or more. The recipient power distribution should be arranged near the device.

FIGURE 2.27 When the under floor height is 300 mm (11.8 in) or more.

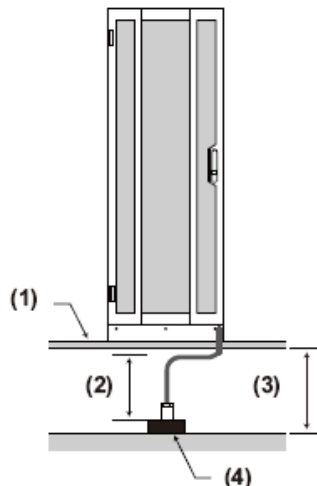

Number	Description
(1)	Free access floor
(2)	200 mm (9.8 in)
(3)	300 mm (11.8 in) or more
(4)	Recipient power distribution

Remarks

The above figure shows an example of 19-inch rack made by Fujitsu Limited mounted with the device.

2.6 Cutoff Characteristics of Distribution Panel (At the time of connecting power distribution box)

At the time of connecting the distribution panel through power distribution box, protection should be coordinated so that the breaker of the device (or power distribution box) trips before the breaker of the distribution panel trips. Such protection should be maintained. Therefore, the distribution panel should have the characteristic conditions shown in "TABLE 2.5 Characteristic Condition of Distribution Panel Breaker". It is necessary to use Distribution panel Breaker suitable to these conditions.

TABLE 2.5 Characteristic Condition of Distribution Panel Breaker

Power input	Device Name	Breaker capacity of Distribution panel Breaker	
		For Japan/general overseas/North America	For Europe
AC200 - 240 V	Power distribution box	30A	32A

Cutoff characteristic is Long-time delay type and the cutoff characteristic equivalent to D (IEC898or IN0641 part II) shown in "FIGURE 2.28 Characteristics of Breaker of Distribution Panel" or cutoff characteristics slower than these characteristics is used.

FIGURE 2.28 Characteristics of Breaker of Distribution Panel

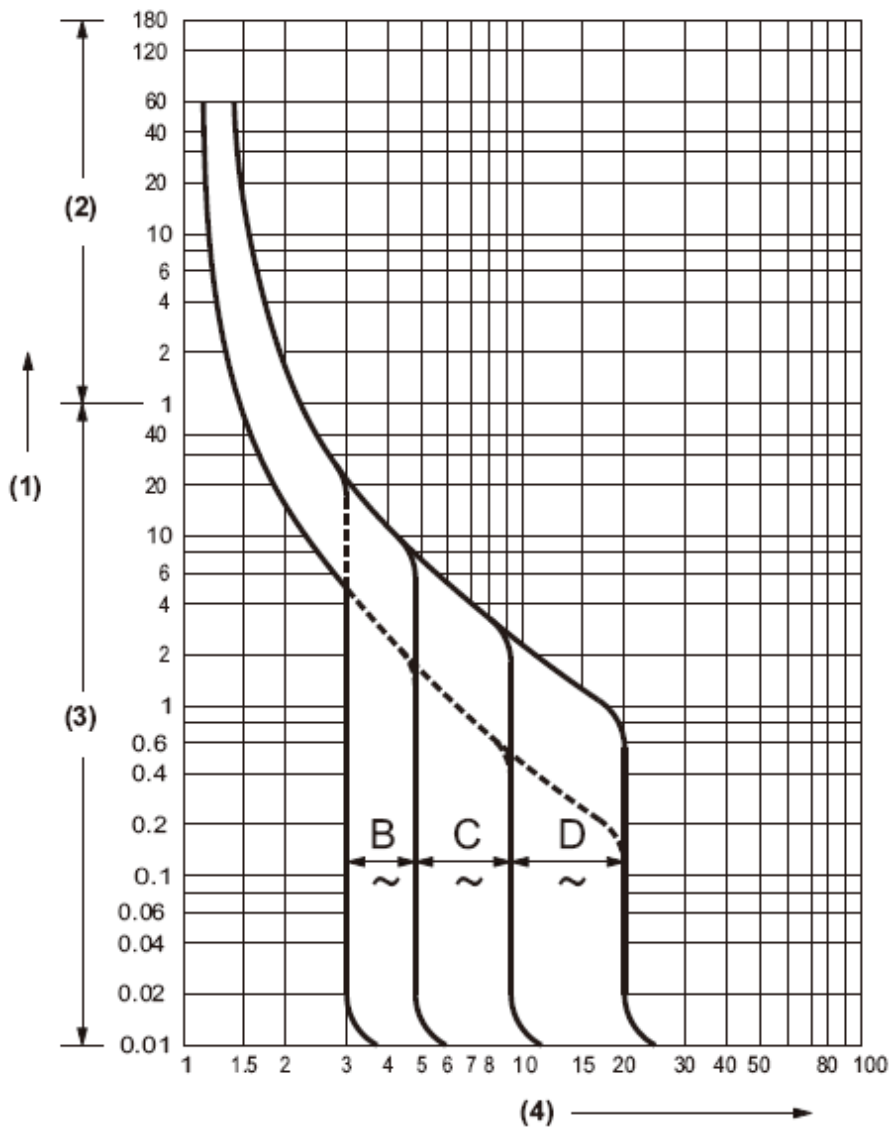

Number	Description
(1)	Operating time
(2)	Minutes
(3)	Seconds
(4)	Electric current (Amplification of rated current)

CHAPTER 3 Notes on Carrying In and Installing the Product

This chapter provides notes on carrying in and installing the PRIMEQUEST 2000 series server.

3.1 Elevator Load Conditions

The rack with the device mounted is wider than the average computer. Therefore, to use an elevator to carry in the rack, the rack may need the side boards or doors removed before loading on the elevator. When using an elevator to carry in the rack, see the elevator load conditions in "TABLE 3.1 Elevator load conditions" and confirm that you are properly loading the rack on the elevator.

TABLE 3.1 Elevator load conditions

Elevator code	Load capacity [kg]	Width (*1)	Depth (*1)	Height (*1)	Width (*2)	Height (*2)	Rack Models 2742/2737/2724/ 2642/2624/2616 Models 1740/1640/1624
P-6-C0	450	1400	850	2300	800	2100	Cannot be loaded
P-9-C0	600	1400	1100	2300	800	2100	Cannot be loaded
P-11-C0	750	1400	1350	2300	800	2100	Can be loaded
P-13-C0	900	1600	1350	2300	900	2100	Can be loaded
P-15-C0	1000	1600 1800	1500 1300	2300	900 1000	2100	Can be loaded
P-17-C0	1150	1800 2000	1500 1350	2300	1000 1100	2100	Can be loaded
P-20-C0	1350	1800 2000	1700 1500	2300	1000 1100	2100	Can be loaded
P-24-C0	1600	2000 2150	1750 1600	2300	1100	2100	Can be loaded

*1 Interior dimensions of the cab [mm]

*2 Door opening dimensions [mm]

3.2 Earthquake Preparedness Measures

The purpose of the earthquake preparedness measures is to prevent the computer from falling and breaking, and to ensure operator safety as well as quick system recovery. To prevent damage to the computer system from an earthquake, Fujitsu provides an earthquake countermeasure called "fixed construction." (A fixed construction prevents the device from falling by fixing it in place.)

The necessity of a fixed construction is determined from the following factors:

- Magnitude of floor vibrations at the installation site
- Whether the floor is a raised floor
- Device structure

Before choosing an earthquake countermeasure and performing the actual work for earthquake preparedness, consult with Fujitsu's engineering works department.

Appendix A Racks

This appendix provides various information on the mounting racks for the PRIMEQUEST 2000 series and PCI_Box.

A.1 Rack Mounting

The PRIMEQUEST 2000 series (including peripheral devices) has been developed and its operation guaranteed with the basic assumption that it is mounted in a Fujitsu rack. For safe use of a unit mounted in a Fujitsu rack, contact the distributor where you purchased your product, or your sales representative.

When mounting the PRIMEQUEST products in a rack manufactured by another company, customers need to confirm on their own responsibility that the rack meets the PRIMEQUEST product specifications and requirements.

See [A.2.2 Requirements for mounting in a rack manufactured by another company](#).

A.2 Rack Mounting Requirements

This section describes rack mounting requirements.

A.2.1 Requirements for mounting in a Fujitsu 19-inch rack

This section explains the requirements for mounting in a Fujitsu 19-inch rack. For safe use of the PRIMEQUEST 2000 series server mounted in a Fujitsu 19-inch rack, observe the mounting requirements described below.

Recommended racks for mounting

The following table lists the recommended racks for mounting the PRIMEQUEST 2000 series server and PCI_Box.

TABLE A.1 Recommended racks for mounting

Fujitsu 19-inch rack	Depth (mm)	Open area ratio
Model 2742	1,050	80%
Model 2737	1,050	80%
Model 2724	1,050	80%
Model 2642	1,050	80%
Model 2624	1,050	80%
Model 2616	1,050	75%
PCR M1 742S	1,050	80%
PCR M1 724S	1,050	80%
PCR M1 642S	1,050	75%
PCR M1 624S	1,050	75%
PCR M1 616S	1,050	75%
PCR M1 742A	1,050	80%
PCR M1 724A	1,050	80%

TABLE A.2 PRIMEQUEST 2000 series external dimensions

Model	Height	Width	Depth
PRIMEQUEST 2000 series	438 mm (10U)	445 mm	782 mm

Note

The Fujitsu 19-inch rack comes with a blank panel covering the front of each empty space that has no mounted device.

If warm exhaust air from the device circulates to the front of the rack and reenters the device, it may cause a temperature alarm and lead to a device failure.

Be sure to use the blank panel to cover the front of an empty space that has no mounted device.

Rack mounting requirements

The following table lists the requirements for mounting in one rack.

Model	Number of mountable units	Mounting area
PRIMEQUEST 2000 series	3	The bottom of the mounted device must not be below 1U. (*1) The top of the mounted device must not be above 1,066 mm from floor. (*2).
PCI_Box	No mounting requirements	

(*1) For the models 2742/2737/2724/2642/2624/2616 and PCR M1 742S/724S/642S/624S/616S/742A/724A, the bottom of the mounted device must not be below 2U.

(*2) For the models 2742/2737/2724/2642/2624/2616 and PCR M1 742S/724S/642S/624S/616S/742A/724A, the top of the mounted device is 22U (1,020 mm).

For details, contact the distributor where you purchased your product, or your sales representative.

FIGURE A.1 Example of rack mounting

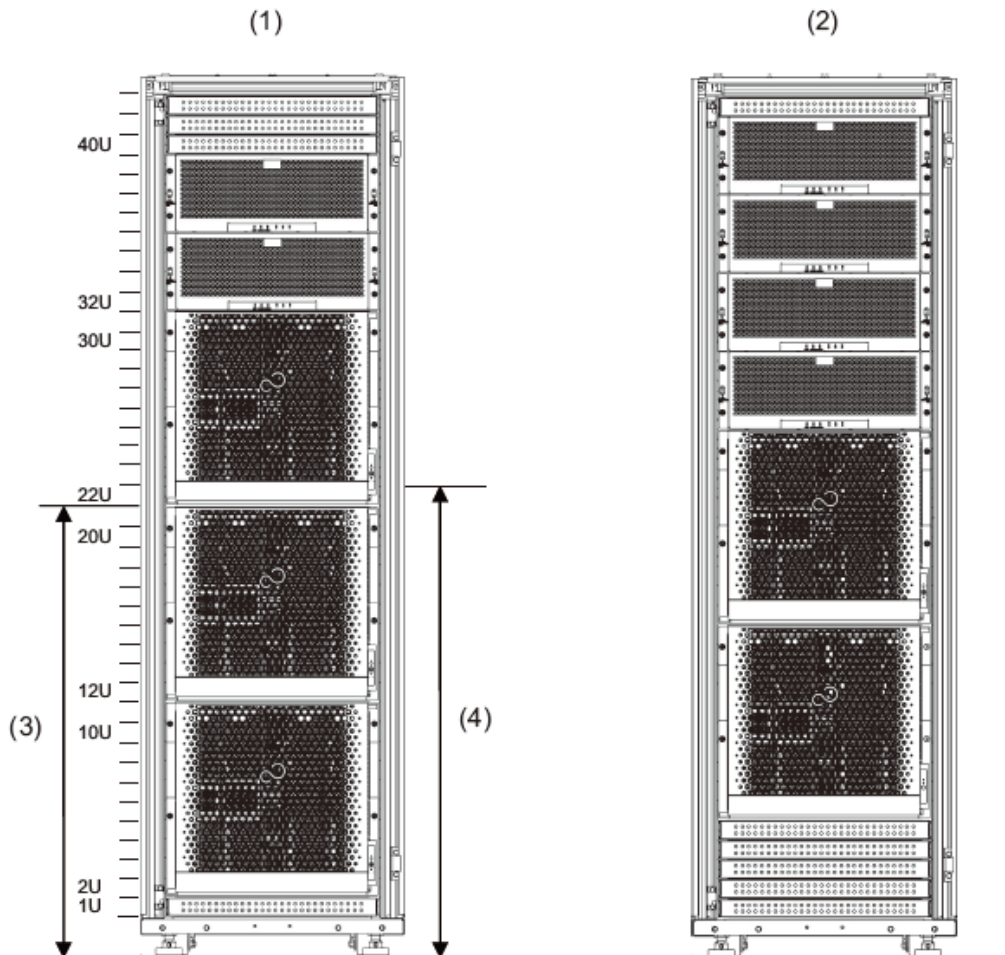

Number	Description
(1)	Example 1 of rack mounting for model 2642
(2)	Example 2 of rack mounting for model 2642
(3)	1,022 mm
(4)	1,060 mm

A.2.2 Requirements for mounting in a third party's rack

When mounting the PRIMEQUEST products in a rack manufactured by another company, customers need to confirm on their own responsibility that the rack meets the PRIMEQUEST product specifications and requirements.

Note

Fujitsu does not guarantee there will be no problems arising from the mounting of the PRIMEQUEST 2000 series server (including peripheral devices) in a rack manufactured by another company.

Examples: Cooling problem due to an insufficient supply of cooling air because of the rack structure, and insufficient earthquake-resistance because the rack manufactured by another company is not strong enough. If mounting in a rack manufactured by another company cannot be avoided, confirm that the rack satisfies all of the following structural requirements.

TABLE A.3 Structural condition of rack

Number of Check	Term	Condition	Reference
Length of rack			
Check1	Allowable spacing between posts	685 to 790mm (26.7 to 31.1 in.)	FIGURE A.2 Length of rack
Check2	Length between front post and front cover	860mm(33.9 in.) or more	FIGURE A.2 Length of rack
Check3	Length between front post and front cover	60mm(2.4 in.) or more	FIGURE A.2 Length of rack
Width of rack			
Check4	distance between the left and right posts (common to the front and rear posts)	450mm(17.7 in.) or more	FIGURE A.3 Width of rack FIGURE A.4 Format of rack posts
Check5	Distance between holes on the left and right device mounting posts (common to the front and rear posts):	465mm(18.3 in) or more (EIA standard)	FIGURE A.3 Width of rack FIGURE A.4 Format of rack posts
Check6	Bracket installation space	There must not be interference thing (post for reinforcement or option) in the shaded portion of figure.	FIGURE A.3 Width of rack
Format of rack			
Check7	Pitch of hole	EIA standard, universal pitch	FIGURE A.4 Format of rack posts
Check8	Format and size of hole	Length of each side of a square hole: 9x9(0.35 in.) to 10x10 mm (0.39 in.)	FIGURE A.4 Format of rack posts
Check9	Cable takeout port	The cable can be taken out of the bottom or rear .	FIGURE A.2 Length of rack
Check10	Loading Carrying Capacity of rack	Total weight must be less than loading Carrying Capacity of rack. Note Loading Carrying Capacity of rack may change when anti-earthquake measures are given.	-
Check11	Open area ratio of rack	Open area ratio of rack of front cover and rear cover must be more than 60%.	-
Check12	Measure to prevent the rack from toppling	Measure to prevent the rack from toppling must be performed.	-

FIGURE A.2 Length of rack

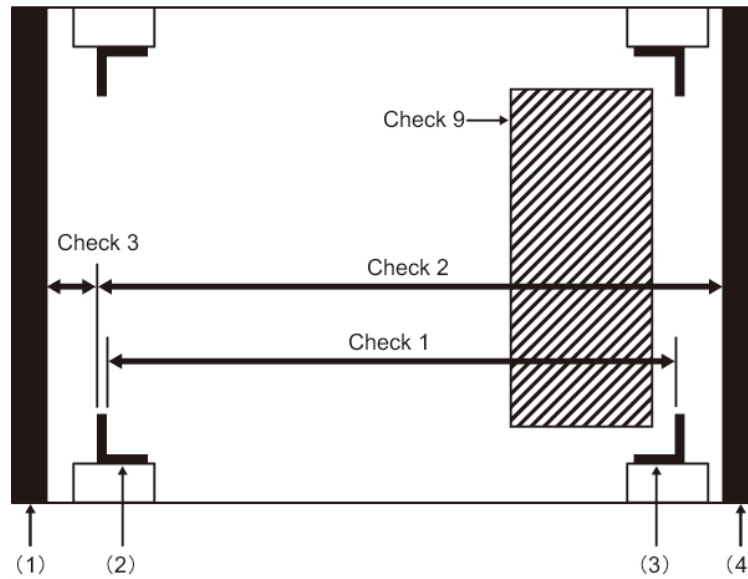

Number	Description
(1)	Front cover
(2)	Front post
(3)	Rear post
(4)	Rear cover

Width of rack

FIGURE A.3 Width of rack

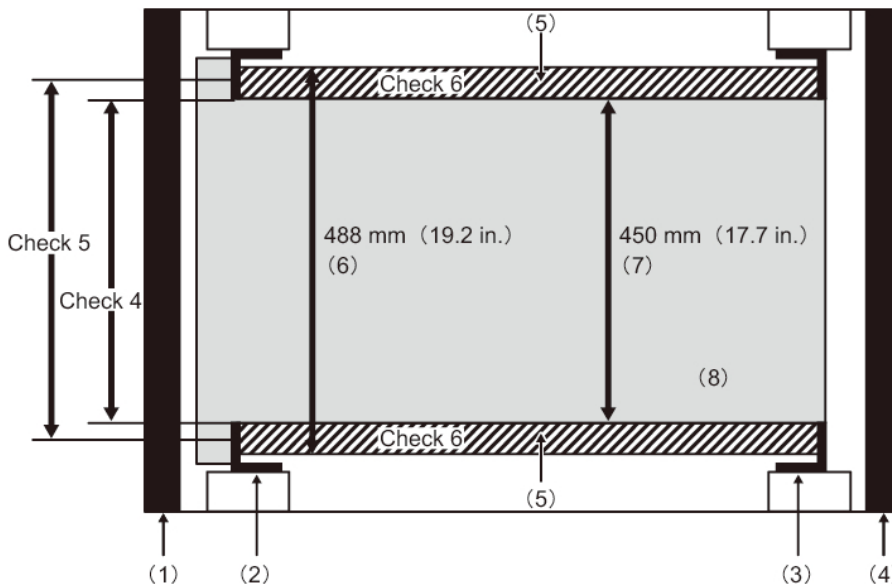

Number	Description
(1)	Front cover
(2)	Front post
(3)	Rear post
(4)	Rear cover
(5)	Bracket installation area
(6)	Width of Bracket installation
(7)	Width of chassis of PRIMEQUEST
(8)	Chassis of PRIMEQUEST

Format of rack posts

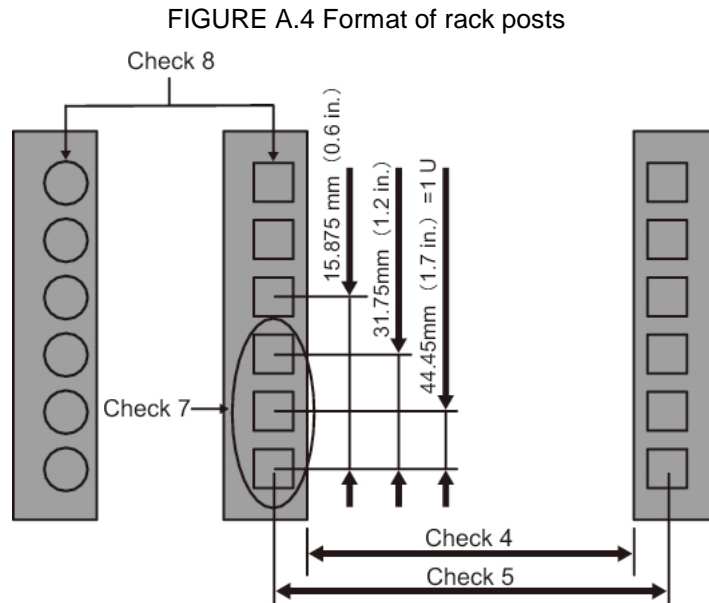

Other conditions

Besides structural conditions, the following conditions must also be considered.

- Cooling of devices mounted in the rack
Install the rack such that the temperature inside the rack satisfies the temperature conditions in “[1.3 Installation Specifications](#)”.
Especially, cover the front of empty spaces in the rack and take other such necessary measures to prevent exhaust air from devices from recirculating to the air intake.
- Securing the maintenance work area (service area)
Secure the service area required for the maintenance work performed by a Fujitsu certified service engineer.
Referring to the Fujitsu rack service areas in [1.4 Installation Area](#) and to the installation manual of the rack used, determine the service areas.

FUJITSU

Free Manuals Download Website

<http://myh66.com>

<http://usermanuals.us>

<http://www.somanuals.com>

<http://www.4manuals.cc>

<http://www.manual-lib.com>

<http://www.404manual.com>

<http://www.luxmanual.com>

<http://aubethermostatmanual.com>

Golf course search by state

<http://golfingnear.com>

Email search by domain

<http://emailbydomain.com>

Auto manuals search

<http://auto.somanuals.com>

TV manuals search

<http://tv.somanuals.com>