

# FURUNO

Publication No. OM-E2213-0J

## OPERATOR'S MANUAL

ECHO-SOUNDER

MODEL FG-11/200 MARK-3

**FURUNO ELECTRIC CO., LTD.**

NISHINOMIYA, JAPAN

July, 1978

7807500J  
PRINTED IN JAPAN

---

# CONTENTS

---

SPECIFICATIONS .....	2
Chapter 1. PRINCIPLE .....	3
Chapter 2. INSTALLATION.....	4
Chapter 3. OPERATING INSTRUCTION .....	7
Chapter 4. MAINTENANCE .....	11
Cleaning of Recorder Unit .....	11
Adjustment of Zero Line .....	11
How to renew the recording stylus .....	12
Replacement of Recording Paper .....	12
Replacement of Batteries (Dry cells) .....	14
Replacement of Transducer .....	14
Chapter 5. TROUBLE SHOOTING .....	15
SCHEMATIC DIAGRAM .....	17

# SPECIFICATIONS OF FG MARK-3 SERIES

## DEPTH RANGES

TYPE	DEPTH RANGES	SOUNDING RATE (PPM)	PAPER ADVANCE (mm/min.)
FG-11-A MARK-3	0- 40- 80-120-160 FA (0- 75-150-225-300 M)	150	10
FG-11-B MARK-3	0- 80-160-240-320 FA (0-150-300-450-600 M)	75	5
FG-200-A MARK-3	0- 12- 24- 36- 48 FA (0- 22- 44- 66- 88 M or, 0- 72-144-216-288 FT)	511	17
FG-200-B MARK-3	0- 20- 40- 60- 80 FA (0- 40- 80-120-160 M or, 0-120-240-360-480 FT)	300	10

## RECORDING PAPER

Dry Electro-sensitive Paper (P-10)  
100mm(4") x 15 Meters  
Effective Width 90mm

## INDICATION

Neon Flashing and Graphical, or Neon Flashing only

## POWER SUPPLY

DC 12V external batteries or built-in 8 pieces of dry cells (continuously 10 hours).  
Power Consumption: 2W approx.  
Built-in power supply adaptor available for operation from main input of DC 24V

## DIMENSIONS AND WEIGHT

8" x 12" x 5<sup>5</sup>/<sub>8</sub>", 10 lbs.  
(204 x 298 x 147 mm, 4.8kg)

## COMPLETE SET

Indicator 1 unit  
Transducer 1 pc.  
Spare Parts 1 set.

## TRANSDUCER

	FG-11 M-3	FG-200 M 3
Material	Barium Titanate Vibrator	
Cable Length	10m	
Type	50B-6G	200B-5
Frequency	50KHz	200KHz
Beam width (3dB)	28°	10°

## STANDARD SPARE PARTS

Recording paper (P-10) 4 pcs.  
Recording stylus with holder 1 pc.  
Recording stylus 5 pcs.  
Fuse 1A 1 pc.  
Pilot lamp 1 pc.

## CIRCUITRY

Fully silicon transistorized  
White Line Facilities  
Output Power 10 Watts  
Pulselength 1.5 millisecc. (FG-11 M-3)  
1.0 millisecc. (FG-200M-3)

# CHAPTER 1. PRINCIPLE

An echo-sounder uses ultrasonic waves to determine the depth to targets, such as schools of fish and the seabed. The delay time between the transmitted pulse and reception of its echo serves to determine the depth to the target. For instance, if the delay time is one second, the depth will be found to be 750m (2,500 feet). Since the echo received is not strong enough to make recordings by itself, it is magnified through the amplifier circuits in order to produce an electrical mark on the paper.

When the main switch is turned on, the magnet located on the driving arm is revolved by the driving motor and each reed switch on the disc is closed to trigger the transmitter circuit through the monostable multivibrator. There are four reed switches selected by the range switch. The transmitter circuit is active while each reed switch is ON and the ultrasonic pulses are emitted into the water. Closing of the selected reed switch makes the monostable multivibrator operate, and RF energy is generated. This RF energy after amplification, is fed to the transducer, and is converted into ultrasonic pulses. A trap circuit is inserted in the receiver input circuit. This circuit disconnects the amplifier circuit during transmission of pulses and connects it during reception of echo signals.

The ultrasonic pulses are emitted in a specific direction determined by the beam width of the transducer.

The pulses are reflected by the underwater object and the echoes are received by the same transducer. The signals received are changed into electric energy and are then magnified by the amplifier and recorded on the paper.

The white line circuit facilitates the detection of schools of fish close to the seabed. The white line circuit consists of the white line amplifier, detector and pulse amplifier. The signal taken from RF amplifier output is amplified by the white line amplifier and is then detected. The pulse amplifier magnifies only those signals larger than the pre-set level. Therefore when a strong signal, such as from the seabed, is applied the white line output is obtained and fed back to the I.F. amplifier with reverse phase. The amplification of the IF amplifier is reduced and the seabed contour is shown as a thin, black line; underneath this line is an un-recorded area, and then the bottom trail. Any fish near or on the bottom echo will appear above the thin black line which distinguishes the fish from the bottom.

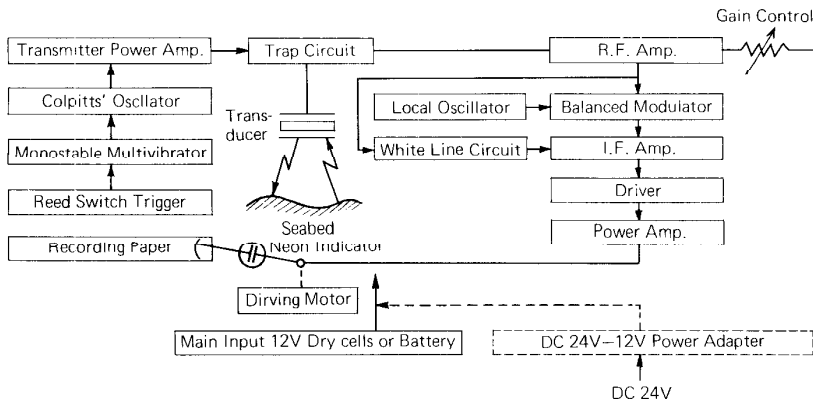

Fig. 1-1 Block Diagram for FG-11/200 MARK-3

## CHAPTER 2. INSTALLATION

### Recorder Unit

The recorder unit can be fixed in any place convenient for operation. Fix the mounting bracket on a table with 2 woodscrews or bolts and nuts. The recorder unit must be connected to the transducer and power supply.

### Power Supply

The recorder can be operated from,  
a) built-in 8 "size-D" dry cell batteries  
b) external 12VDC battery (Remove dry cells from the recorder unit.)  
c) DC24V if a power adaptor is fitted in the recorder.

### Transducer

The transducer is usually installed on the hull bottom after cutting a small hole in the hull plate. (Refer to Fig. 2-2 and 2-3). For portable operation, the transducer may be clamped on the ship's sideboard as

shown in Fig. 2-4. In FRP boat where cutting a hole is not preferable, the transducer may be fitted inside the hull (see Fig. 2-5). In this case, sounding capacity is sacrificed.

### Precautions for transducer installation:

- 1) Select a place as far from engine and generator as possible.
- 2) Install the transducer within 900mm (3ft) from the keel.
- 3) In a small ship, the mid-ship position is usually a good place for the transducer.
- 4) To minimize effect from aerated water, a proper projection is required, however, within line of the keel's lowest point.
- 5) When tightening the through-hull pipe, too much pressure may damage the transducer cable. Screw in the lock nut and cap nut by hand then screw in the cap nut about two turns with a spanner. Apply jute, paint or putty on threads of the pipe before tightening the nuts.

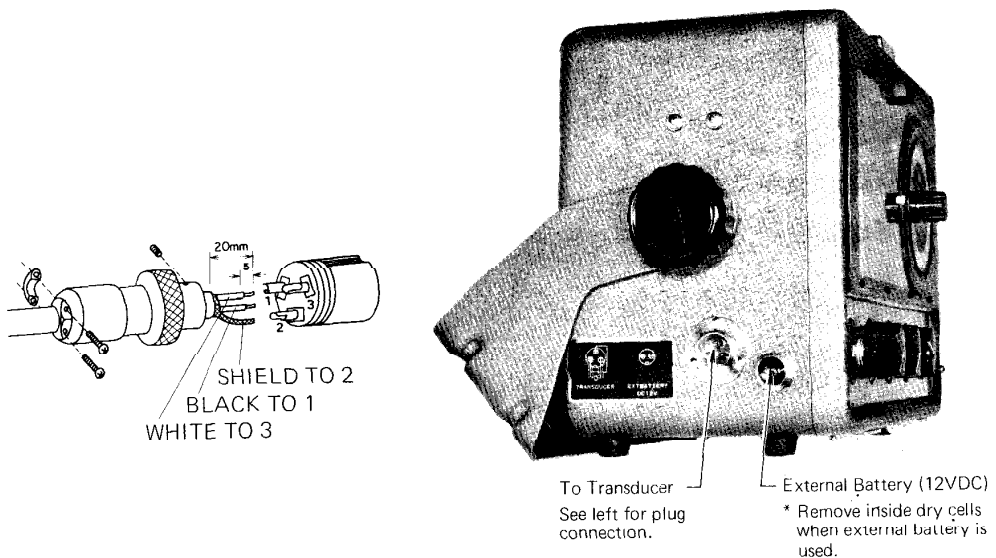

Fig. 2-1

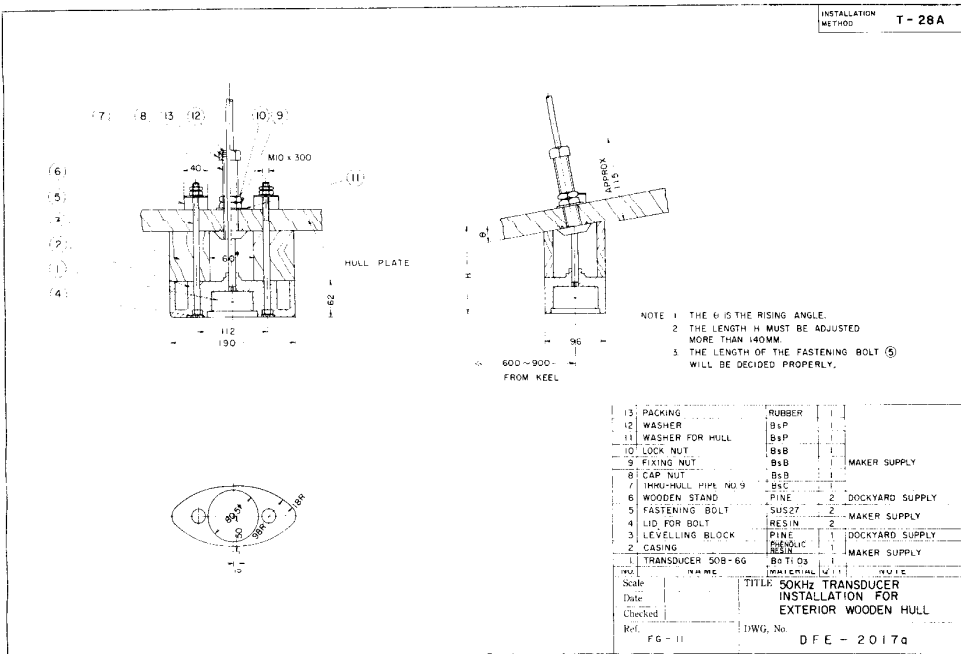

Fig. 2-2

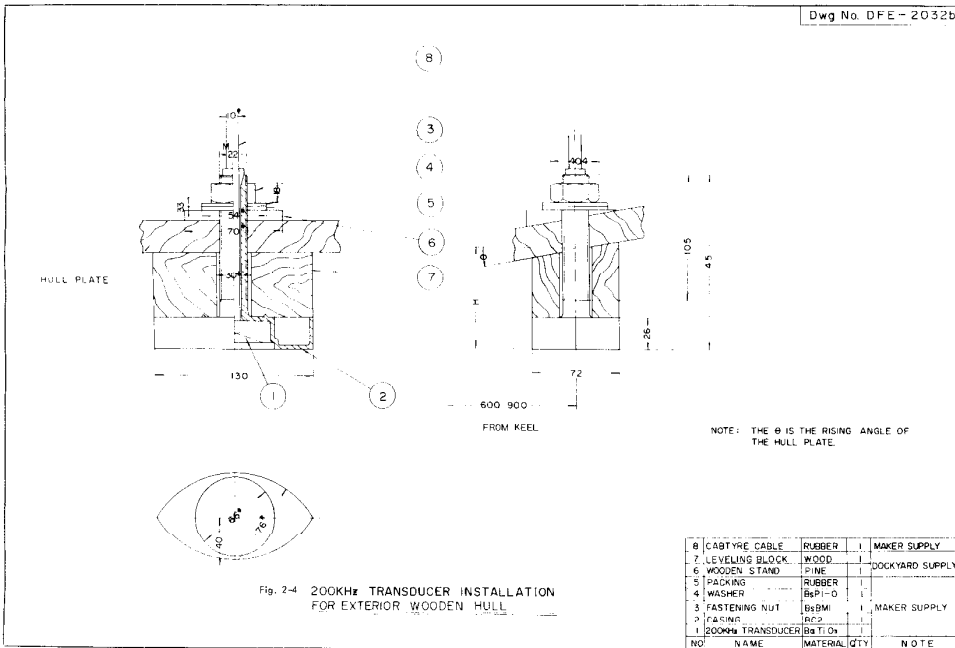

Fig. 2-3

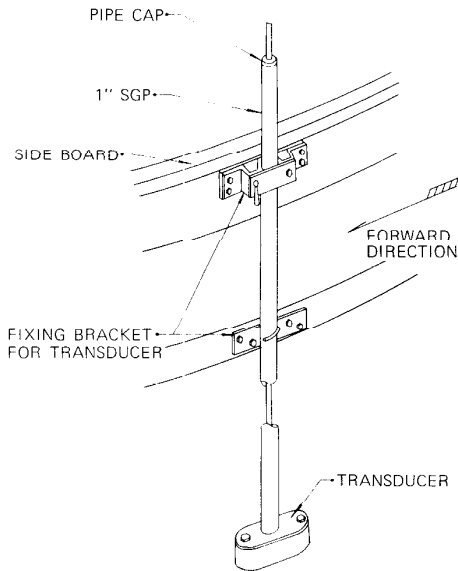

Fig. 2-4 Transducer Side Board Installation

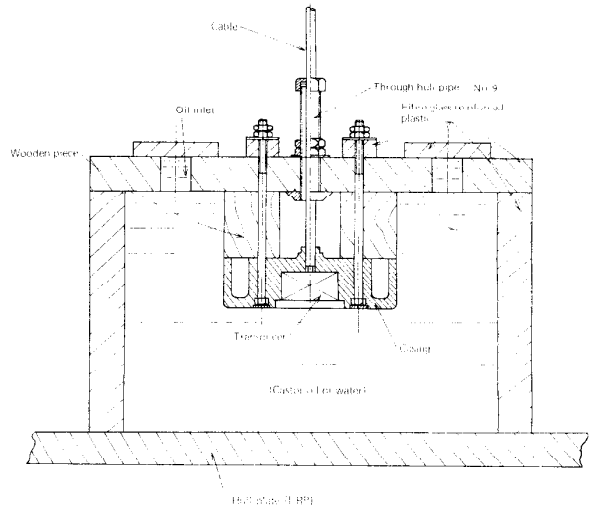

Fig. 2-5 FRP Transducer Tank (Interior Installation)

### DC24V—12V Power Adaptor

For operation from external DC24V supply, the DC24V—12V power adaptor is available to provide regulated DC 12V to the equipment from mains of DC22V to 28V.

#### How to install the Adaptor

- 1) Take the battery case out of the cabinet; then disconnect the orange and white lead wires from the case.
- 2) Remove the red and white lead wires from the power cable connector.
- 3) Connect the orange lead wire to point (O) and the white lead wire to point (U).
- 4) Fix the adaptor with two screws at the place where the battery case had been set.
- 5) Connect the red and white wires of adaptor to (+) and (-) terminals on the power cable connector individually.

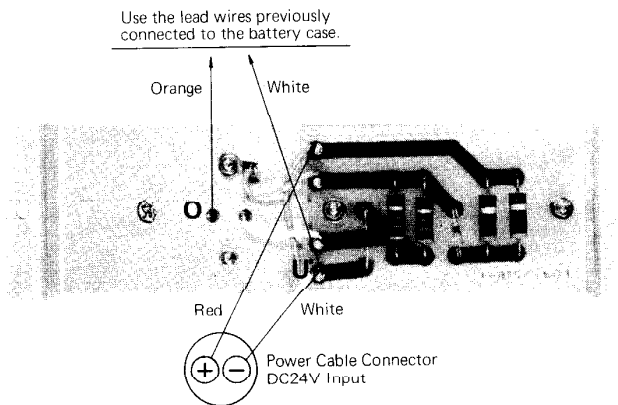

Fig. 2-6 Power Adaptor

## CHAPTER 3. OPERATING INSTRUCTIONS

All the controls used in normal operation are arranged on the front panel as shown in Fig. 3-1.

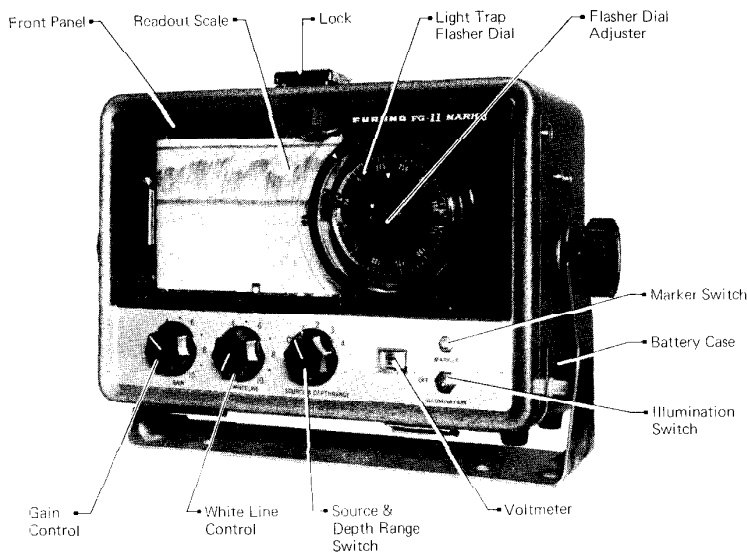

Fig. 3-1 Front View of FG-11/200 Mark-3

### 1) Source and depth range switch

Turn the switch clockwise from "off" to the desired position. There are 4

depth ranges with respect to each model and subtype as below:

FG-11	1	2	3	4	
Type A:	0- 40	40- 80	80-120	120-160	fathoms
	0- 75	75-150	150-225	225-300	meters
Type B:	0- 80	80-160	160-240	240-320	fathoms
	0-150	150-300	300-450	450-600	meters

FG-200	1	2	3	4	
Type A:	0- 12	12- 24	24- 36	36- 48	fathoms
	0- 22	22- 44	44- 66	66- 88	meters
	0- 72	72-144	144-216	216-288	feet
Type B:	0- 20	20- 40	40- 60	60- 80	fathoms
	0- 40	40- 80	80-120	120-160	meters
	0-120	120-240	240-360	360-480	feet



## 2) Gain control

Adjust the Gain Control to obtain a clear-cut recording on the paper. The sensitivity of the amplifier is varied by turning this knob. Decrease the sensitivity slightly if much surface noise appears.

## 3) White line control

The echo trace of the seabed can be discriminated by a thin, black line over a white belt so that fish close to it, or in contact with it, may be clearly identified.

## 4) Voltmeter

This meter indicates the supply voltage. Dry cells should be replaced when the meter reads in the red.

## 5) Marker switch

When the switch is depressed, a dense black line appears on the recording paper. Use this function when you want to check the contact condition of the recording stylus or to make a reference marking.

## 6) Illumination switch

If illumination is necessary, turn the switch "on". In order to conserve the dry cells leave this switch in the "off" position until needed.

## 7) Flasher Dial adjuster

The neon tube flashes when the transmitting pulse is emitted and the echo is received. Turn the flasher dial adjuster so that the range number in use appears in the small window on the circular dial.

## 8) Independent neon flashing indication with recorder mechanism stopped

When no graphical indication is required, neon flashing can be independently carried out by swinging the plastic front panel forward and sliding the recorder stop lever below the recording plate inside the unit to the left. The recording paper will stop running. Lift the stylus off the paper by turning the stylus lever as shown below:

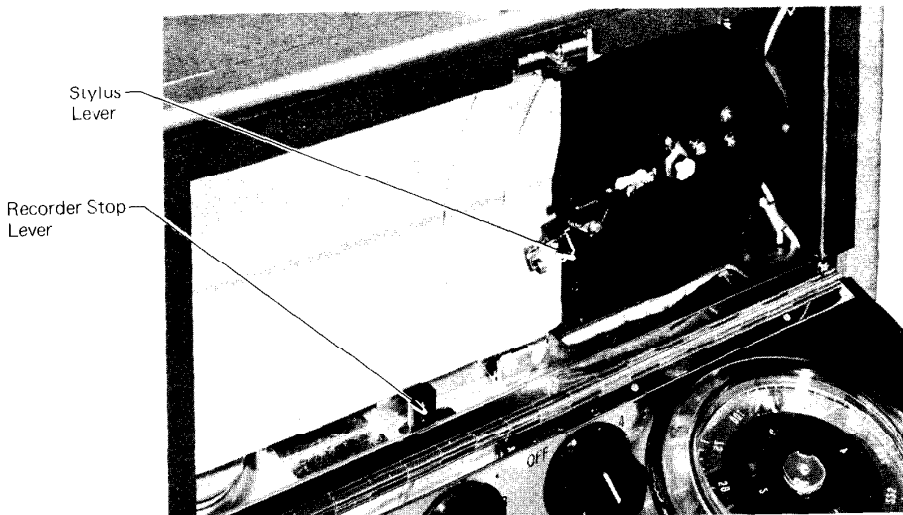

Fig. 3-2 Recorder, with the front panel opened

## Observation of Recordings

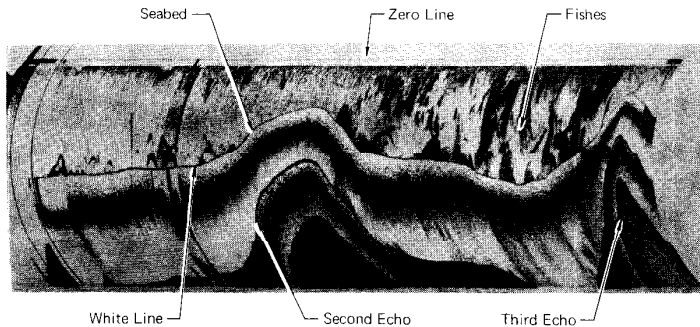

Fig. 3-3 Typical Recording

### 1) Zero line

The zero line appears at the upper edge of the recording paper when the depth range switch is set to range "1", and it does not appear when the range switch is at the other settings. The line shows the position of the radiation surface of the transducer. Adjustment of this line (zero set) is explained in chapter 4-2.

### 2) Echoes from Schools of Fish

The fish echo is usually weaker than the echo of the seabed, and the size of the school of fish is ascertained from the density of the recording. The Gain Control must be adjusted carefully in order to discriminate between fish and noise.

### 3) Indication of seabed

The strongest echo is received from the seabed. Under the shallow depth sounding,

the second or third echo may appear at recurring intervals.

The intensity of the seabed echo can be used to determine the type of bottom. The harder the bottom, the wider the bottom trace.

### 4) White Line Recordings

White line operation is used to discriminate between the seabed and schools of fish close to the seabed. Generally the echo from the seabed is very strong compared with echoes from fish. The white line circuit is operated by the difference in signal levels. Schools of fish close to the seabed can be easily observed by proper setting of the white line control (Fig. 3-4a).

The hard seabed provides a wider area of receiver blocking by the white line circuit as in Fig. 3-4b (Part A and B).

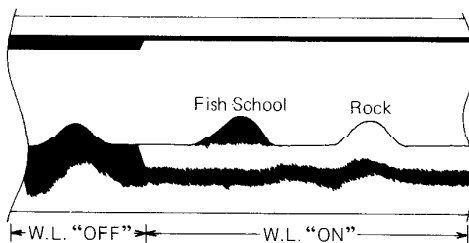

Fig. 3-4a

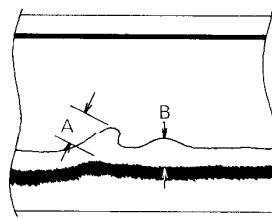

Fig. 3-4b

### 5) Surface noise

Noise appearing near the surface is caused by the wake of another boat or aeration. Similar noise sometimes appears when a plankton layer or water temperature difference (thermocline) exists.

### 6) Induction and interference

Noise caused by the induction from other electric circuits or interference from other echo sounders may sometimes appear on the recording paper. These interferences are recorded on the paper as shown in Fig. 3-5 and can be reduced by decreasing the amplifier gain.

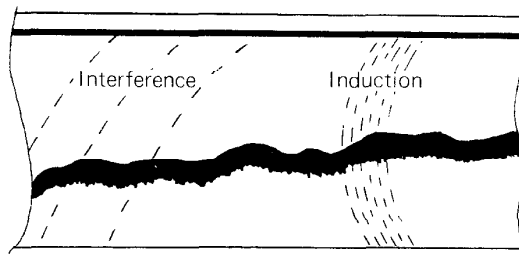

Fig. 3-5

### 7) Effect of rolling and pitching

If the vessel rolls and pitches on rough sea, the normal sea trace becomes a zigzag, sawtooth recording.

### 8) Effect by sidelobes

When the shape of the seabed is steep, a ghost image is caused by the sidelobe of the beam but this should not cause confusion as it is lighter than the actual seabed trace (Fig. 3-6a).

The effect of the sidelobes also appears on a flat seabed as in Fig. 3-6b.

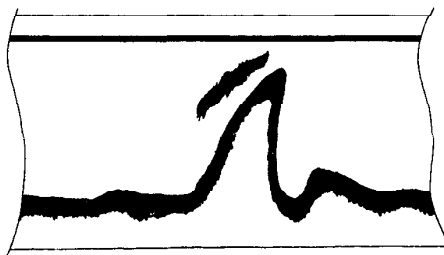

Fig. 3-6a

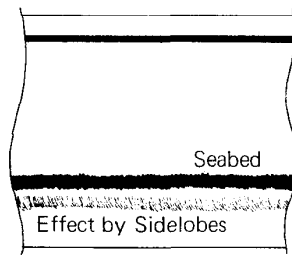

Fig. 3-6b

## CHAPTER 4. MAINTENANCE

### 4-1. Cleaning of Recorder Unit

As dry electrosensitive paper is used in this set, some carbon powder will pile up in the inner mechanism. The interior should be cleaned every week to avoid carbon build up and possible malfunction. The recorder can be cleaned with the plastic front panel swung forward. The front panel is secured by a ball catch which will release when the finger grip is pulled.

### 4-2. Adjustment of Zero Line

If the position of zero line recorded on the paper shifts from "0" reading of scale, as shown in Fig. 4-1, it can be reset by the zero line adjuster. Loosen the lock-screw and move the zero line adjuster right or left so that the zero line coincides with the "0" point of scale. (See Fig. 4-2). As the stylus wears down it will lose contact with the paper. Proper operation can be restored by pulling the wire thru the tube so that contact is maintained.

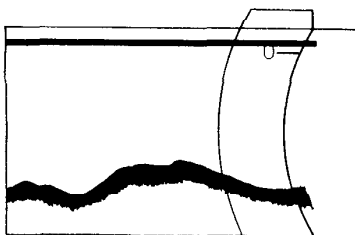

(a) Zero line positioned above "0" of scale  
Fig.4-1a

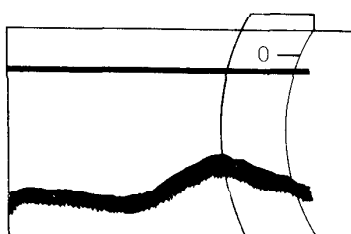

(b) Zero line positioned below "0" of scale  
Fig.4-1b

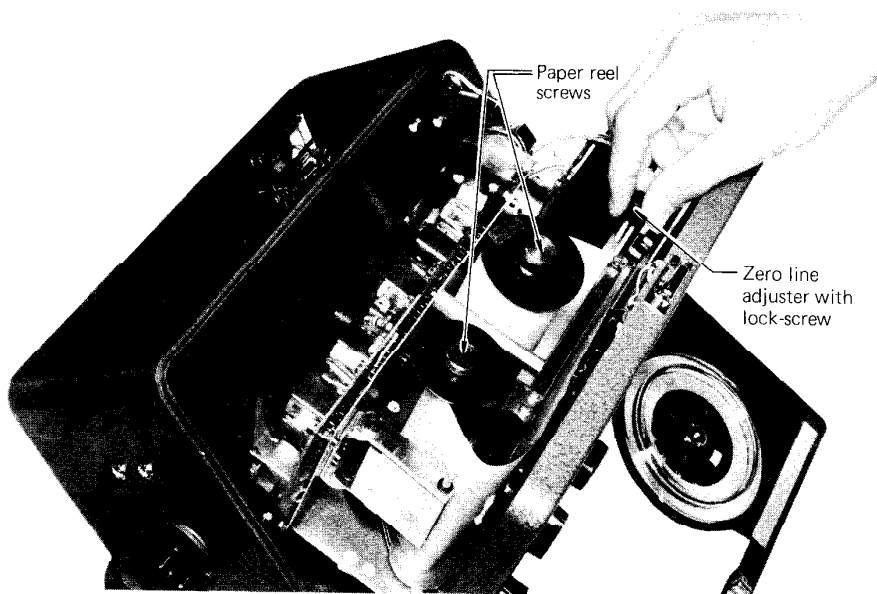

Fig. 4-2

#### 4-3. How to renew the recording stylus.

Fig. 4-3 shows the location of the recording stylus. The coiled stylus is fed to the paper through a small tube. When the stylus has

worn and become shortened, correct it by withdrawing its end (about 10 mm). If the stylus is worn out, replace the whole stylus.

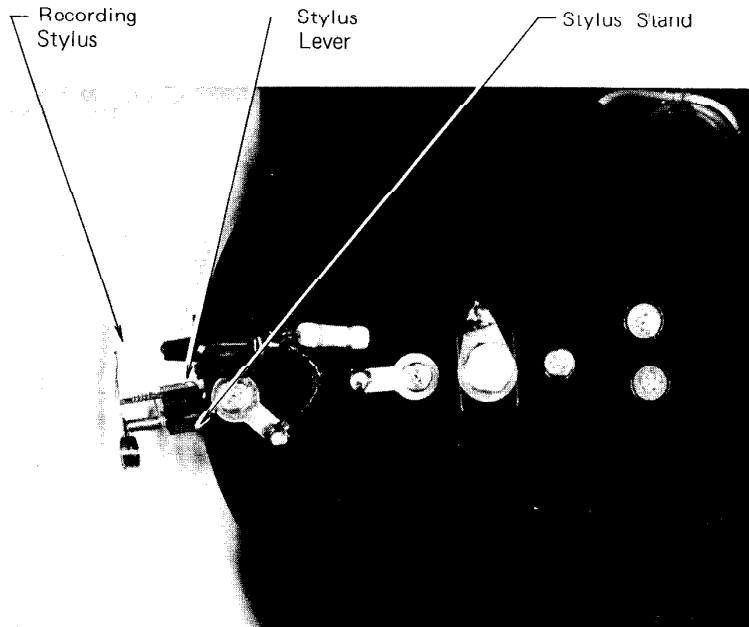

Fig. 4-3

#### 4-4. Replacement of Recording Paper.

**This is performed as follows:**

- 1) Release the recorder unit lock and pull the panel towards you.
- 2) Turn the rotating disc anti-clockwise by hand until the stylus is clear of the paper.
- 3) Rotate the paper winding knob clockwise to completely roll the paper out of the machine. See Fig. 4-4.
- 4) Loosen the two screws which hold the spools.
- 5) Set the new paper roll over the holder and pull out the paper as shown in Fig. 4-5.
- 6) Insert end of the paper into the slot of the paper take-up reel and wind the paper two or three turns.
- 7) Set the paper take-up reel over the holder.
- 8) Reset the tension roller.
- 9) Reset the reel holding screws tightly and lock the recorder unit.

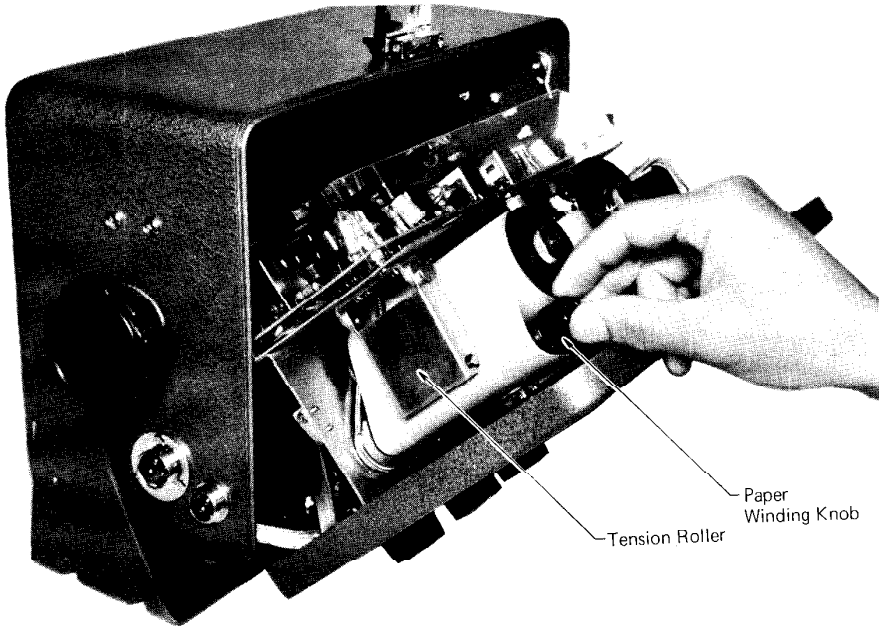

Fig. 4-4

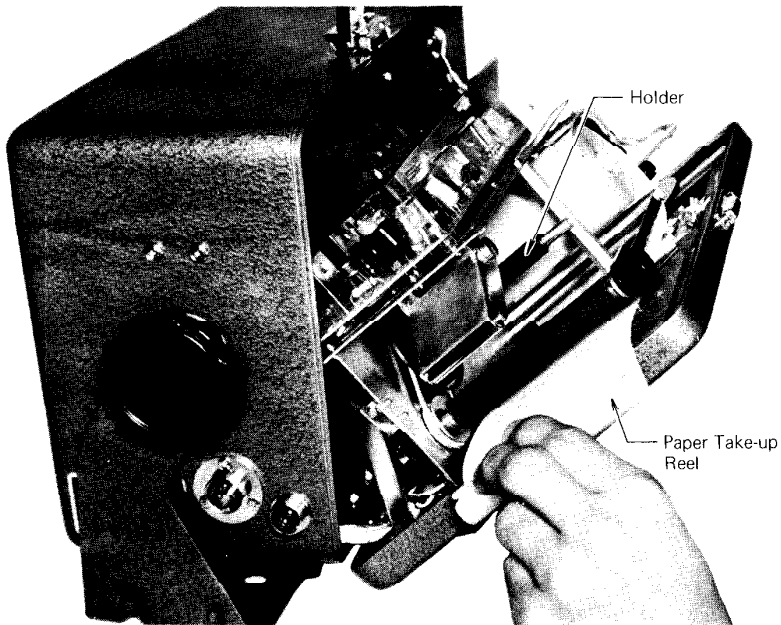

Fig. 4-5

#### 4-5. Replacement of Batteries (Dry cells)

Batteries will normally have to be replaced after about ten hours' operation. After opening the cover of the battery case located on the right side, pull out the used

batteries. The eight new batteries should be inserted into the battery case, taking care of polarity.

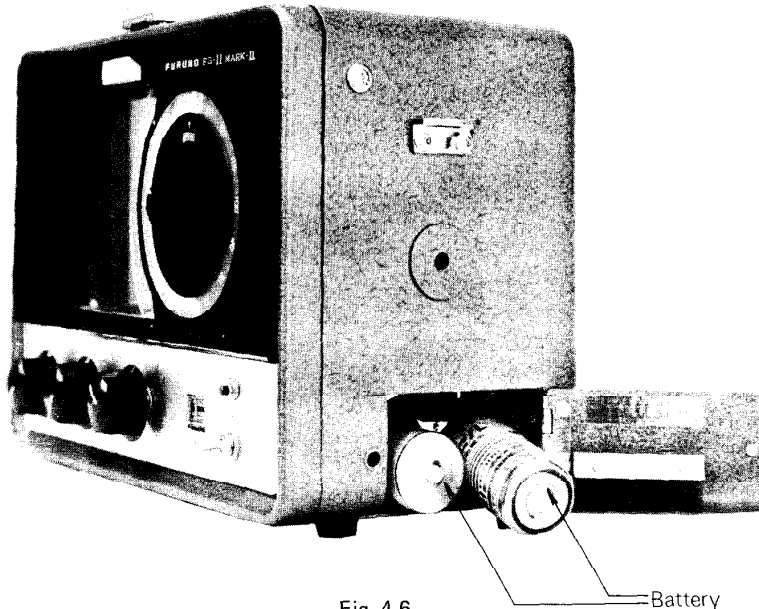

Fig. 4-6

#### 4-6. Replacement of Transducer

The model FG-200 MARK-3 operates with a transducer of nominal frequency of 200KHz.

The transducer is made of barium titanate, and it is hard to get all the transducers exactly defined to 200KHz. There is a slight variation in working frequency from transducer to transducer.

The shipped echo-sounder is properly combined with the transducer and no adjustment is required during the initial installation.

Upon combining a new transducer, adjustment is needed in the recorder unit on the following transformers:

T108A	Local oscillator transformer
T201E	Oscillator transformer
T203E	T/R transformer

Adjustment is made by properly turning the core of respective transformers. When scope and test instruments are available, refer to the Service Manual, Publication No. SM-3055.

If the testing instruments are not available, take an approximate tuning. To increase the working frequency of the transformers, turn the core anticlockwise, observing the recording condition. To decrease the working frequency, turn the core clockwise. In both cases, the adjustment will and should be within one full turn of the core.

## CHAPTER 5. TROUBLE SHOOTING

Trouble	Cause	Remedy
<b>Not working at all</b>	<ol style="list-style-type: none"> <li>1) Wrong battery polarity</li> <li>2) Defective battery</li> <li>3) Fuse blown out</li> </ol>	<ol style="list-style-type: none"> <li>1) Check whether the power cable is connected correctly.</li> <li>2) Check the source voltage. If sudden voltage drop appears when the source switch is turned on, the batteries are defective. Replace them with new ones.</li> <li>3) If a fuse is burnt out on account of over-current there may be some defect in the set. Check the transistor Tr105, polarity of battery and other wiring before the fuse is renewed.</li> </ol>
<b>No recording</b>	<ol style="list-style-type: none"> <li>1) Bad recording stylus. neon flash normal</li> <li>2) Bad contact between the carbon brush and the collector boss.</li> <li>3) Bad amplifier</li> </ol>	<ol style="list-style-type: none"> <li>1) Press the Marker Switch and check the contact condition of the recording stylus. If the stylus is worn away, pull it out.</li> <li>2) Clean the carbon brush and the collector boss completely.</li> <li>3) Repair or replace printed board.</li> </ol>
<b>Pilot lamp lit but motor not rotating</b>	<ol style="list-style-type: none"> <li>1) Low supply voltage</li> <li>2) Defective motor or associated circuit</li> </ol>	<ol style="list-style-type: none"> <li>1) Check to see whether the rated supply voltage is applied.</li> <li>2) If the number of revolutions decreases and the power consumption increases. replace the motor.</li> </ol>
<b>Irregular zero line</b>	<ol style="list-style-type: none"> <li>1) Check reed switch and oscillation circuit</li> </ol>	<ol style="list-style-type: none"> <li>1) Replace if defective.</li> <li>2) If the oscillation circuit is faulty, no zero line appears. Repair or replace the printed circuit board.</li> </ol>
<b>Noise</b>	<ol style="list-style-type: none"> <li>1) Noise caused by other electric machine in the boat</li> <li>2) Bad transducer</li> <li>3) Bad installation or wiring</li> </ol> <p style="margin-left: 20px;">During normal operation, little noise appears with a maximum gain.</p>	<ol style="list-style-type: none"> <li>1) Noise coming from other electric machines is mainly caused by rotating machines such as generators or motors. Identify the noisy motor by switching the motors off one at a time. Take necessary steps to suppress noise from this motor.</li> </ol>



Trouble	Cause	Remedy
Noise (continued)		2) Noise caused by a bad transducer will appear when its cable becomes defective after lengthy use. In this case, a decrease of sensitivity will be encountered. 3) Press transducer cable away from electrical wiring to reduce chance of mutual induction.
Poor sensitivity	1) Frequency deviation of the amplifier or the oscillator circuit 2) Low supply voltage 3) Bad transducer 4) Broken transformers T101 through T109.	1) If the center frequency of amplifier deviates, readjust it and check to see if the rated gain is obtained. Adjustment of transmission frequency is accomplished by observing the Lissajous' figure. Connect the transducer taps. (2) and (3), to the vertical input of an oscilloscope and a standard signal generator to the horizontal of same. Adjust T201E/G and T202A/B so that the circular waveform is obtained on the C.R.T. 2) Check the supply voltage to see whether it is within allowance (10.5–15V). 3) Replace the transducer. 4) Check the transformers, and replace them if necessary.
Readout Error	1) Incorrect gear/motor 2) Incorrect scale and/or flasher dial	1) Check the sounding rate, referring to the specifications. Replace the gearbox or readout scales if necessary. 2) Replace the scale and dial.

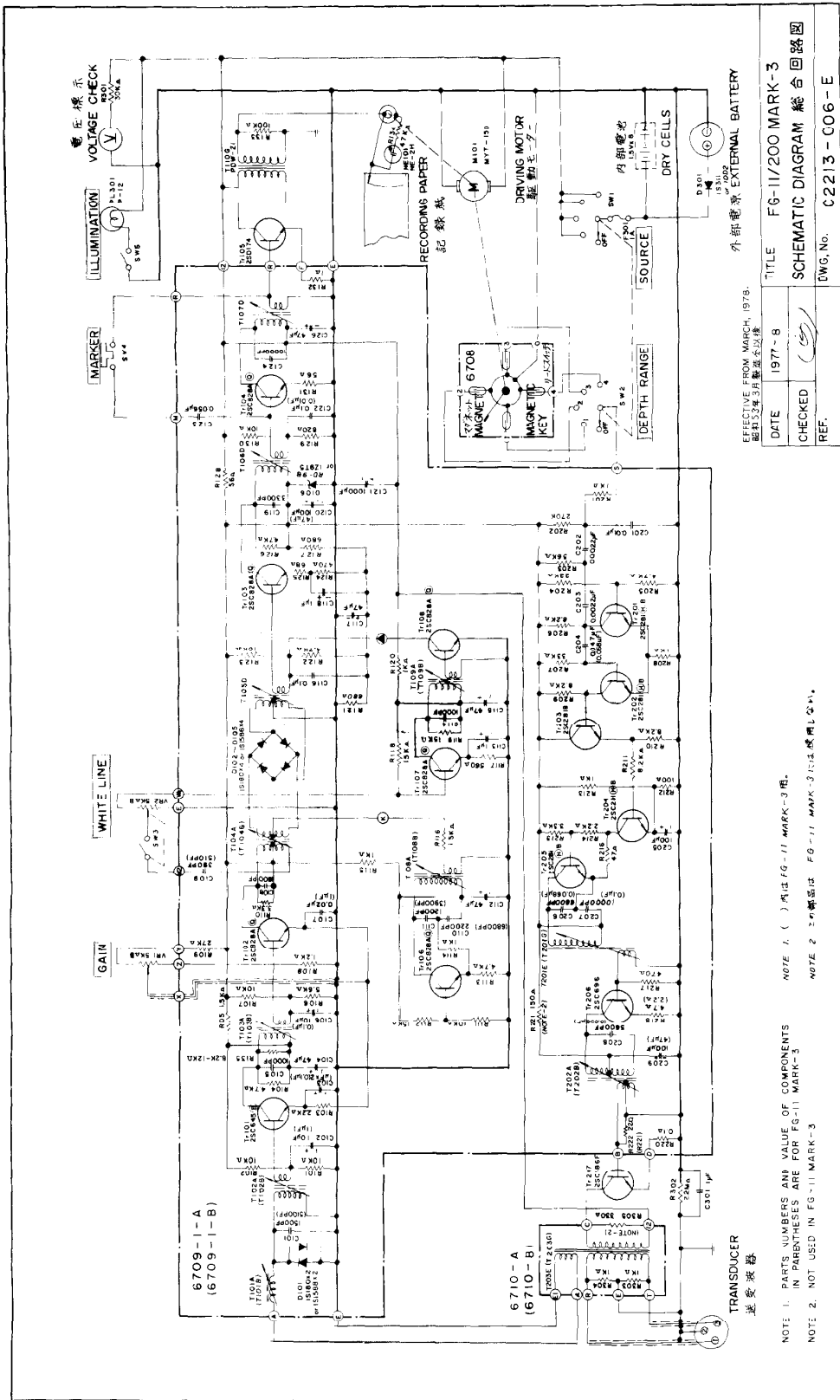

EFFECTIVE FROM MARCH, 1978.  
 昭和52年3月製造品以後

TITLE	FG-11/200 MARK-3
DATE	1977-8
CHECKED	<i>[Signature]</i>
REF.	
DWG. No.	C2213-C06-E

NOTE 1. PARTS NUMBERS AND VALUE OF COMPONENTS IN PARENTHESES ARE FOR FG-11 MARK-3

NOTE 2. 一部の部品は FG-11 MARK-3 に適用し得ない。

FURUNO ELECTRIC CO., LTD.

## Free Manuals Download Website

<http://myh66.com>

<http://usermanuals.us>

<http://www.somanuals.com>

<http://www.4manuals.cc>

<http://www.manual-lib.com>

<http://www.404manual.com>

<http://www.luxmanual.com>

<http://aubethermostatmanual.com>

Golf course search by state

<http://golfingnear.com>

Email search by domain

<http://emailbydomain.com>

Auto manuals search

<http://auto.somanuals.com>

TV manuals search

<http://tv.somanuals.com>