

# **FURUNO**

# **OPERATOR'S MANUAL**

**VIDEO SOUNDER**

---

**MODEL FMV-605**

---



**FURUNO ELECTRIC CO., LTD.**  
**NISHINOMIYA, JAPAN**

**©FURUNO ELECTRIC CO., LTD.**

9-52, Ashihara-cho,  
Nishinomiya, Japan 662

Telephone: 0798-65-2111  
Telefax: 0798-65-4200

-Your Local Agent/Dealer

All rights reserved. Printed in Japan

FIRST EDITION : AUG 1991  
E : FEB. 2, 1993

(HAUS)

PUB. No. OME-23360  
FMV-605



# A Word To Furuno FMV-605 Owners:

Congratulations on your choice of the FURUNO FMV-605 Video Sounder! We are confident that you will enjoy many years of operation with this fine piece of equipment.

For over 40 years Furuno Electric Company has enjoyed an enviable reputation for quality and reliability throughout the world. This dedication to excellence is furthered by our extensive global network of agents and dealers.

The FMV-605 Video Sounder is just one of the many Furuno developments in the field of echosounding. The compact, lightweight but rugged unit is easy to install and operate and is suitable for both fresh and salt water applications.

This unit is designed and constructed to give the user many years of trouble-free operation. However, to obtain optimum performance from this unit, you should carefully read and follow the recommended procedures for installation, operation and maintenance. No machine can perform to the utmost of its ability unless it is installed and maintained properly.

We would appreciate feedback from you, the end-user, about whether we are achieving our purposes.

Thank you for considering and purchasing Furuno equipment.

## FEATURES

The FMV-605 is a single-frequency video sounder which has a large variety of functions, all contained in a splash-proof rugged plastic case that is compact to fit small size boats.

- Thought of user-friendly design have brought a simple operation.
- A wide variety of presentation modes (incl. bottom-lock expansion, marker zoom and unique bottom zoom display), using potent 150W transceiver (50 or 200kHz frequency), and NAV data display are available.
- 4-intensity presentation (including background), on a 6" diagonal CRT, gives you detailed information on fish density and the nature of the bottom.
- AUTO function permits unattended range and gain setting operations. The range scale changes automatically so that the bottom is displayed on the lower half of the screen, selecting the gain suitable for the range.

- Digital display of navigational data and water temperatures in addition to water depth ensures finding of best fishing ground and safe navigation.
- Alarm may be activated. The operator is alerted when bottom echoes or fish echoes enter into the preset alarm zone.
- Five pulselengths from 0.2 to 2.0 msec. for excellent short range and deep range performance.

# Table of Contents

<b>A Word To Furuno FMV-605 Owners:</b> .....	<b>i</b>
<b>FEATURES</b> .....	<b>i</b>
<b>SPECIFICATIONS</b> .....	<b>1</b>
<b>PRINCIPLE OF OPERATION</b> .....	<b>6</b>
<b>1. INSTALLATION</b> .....	<b>7</b>
<b>1.1 TRANSDUCER INSTALLATION</b> .....	<b>7</b>
Overview .....	7
Location .....	7
Through-Hull Mount .....	8
Overview .....	8
Mounting Procedure .....	8
Inside-Hull Mount .....	10
Mounting Location .....	10
Mounting Procedure .....	10
Transducer Preparation and Painting .....	11
<b>1.2 DISPLAY UNIT INSTALLATION</b> .....	<b>12</b>
Mounting .....	12
Mounting Location .....	12
Mounting Display Unit using Bracket .....	13
Mounting Display Unit using Optional Flush Mount Kit .....	13
Installation of Rubber Vibration Isolator .....	14
Cable Connections .....	14
Transducer Cable Connection .....	14
Power Cable Connection .....	14
Connection to Position Fixing Equipment .....	14
Grounding .....	16
<b>2. OPERATION</b> .....	<b>17</b>
<b>2.1 BASIC OPERATION</b> .....	<b>17</b>
Power ON/OFF .....	18
Brilliance Control .....	18
Presentation Mode Selection .....	18
Marker Zoom (M/Z) Presentation .....	18
Bottom-Lock Expansion Presentation .....	19
Bottom Zoom Presentation .....	20
Navigation Data Presentation .....	20
Range Selection .....	21
Introduction .....	21
Basic Range Selection .....	21
Range Shifting .....	21
Gain Control Setting .....	22

AUTO Mode .....	22
Picture Advance Speed Selection: .....	23
Overview .....	23
Guideline .....	24
Signal Threshold Selection (SIG LEV Key) .....	24
Selecting Echo Brightness Gradation (HUE Key) .....	24
<b>2.2 ADVANCED OPERATION .....</b>	<b>26</b>
Selecting Display Data (SHIFT Key) .....	26
Using Alarm Function .....	26
Introduction .....	26
Procedure .....	26
Compensating Water Temperature Indication .....	27
Compensating Ship's Speed Indication .....	28
<b>2.3 INDICATOR .....</b>	<b>29</b>
Echo Sounder Picture .....	29
Normal Mode .....	29
Normal + Bottom Lock (B/L) Expansion Mode .....	29
Normal + Marker Zoom (M/Z) Mode .....	30
Utilizing Water Temperature Indication .....	31
Reading Water Temperature Graph .....	31
<b>3. INTERPRETING THE DISPLAY .....</b>	<b>33</b>
Frequency .....	33
Detecting Area .....	33
Zero Line .....	34
Fish School Echoes .....	35
Bottom Echo .....	35
Surface Noise/Aeration .....	36
<b>4. MAINTENANCE .....</b>	<b>37</b>
General .....	37
Fuse Replacement .....	37
Cleaning And Lubrication .....	37
Maintenance Of The Transducer .....	38
<b>5. Troubleshooting .....</b>	<b>39</b>
Basic Troubleshooting .....	39
Transducer Check .....	41
Speed/temperature Sensor Check .....	41
<b>6. HOW TO CHANGE AND ADJUST INTERNAL SETTINGS .....</b>	<b>43</b>
Change Of Specifications .....	43
<b>7. INSTALLATION OF OPTIONAL DEVICES .....</b>	<b>44</b>
Transom Mount of Transducer .....	44
Introduction .....	44
Procedure .....	44
Mounting transom Type Transducer using Kick-up Bracket (OP02-29) .....	45
Mounting Transom Type Sensor (ST-01PTB) .....	46
Mounting Temperature Sensor .....	47

Mounting Temperature Sensor .....	47
Transom Type (T-02MTB) .....	47
Thru-hull Type (T-02MSB, T-03MSB) .....	47
Mounting Procedure .....	48
Mounting Display Unit using Optional Flush Mount Kit .....	49
Attaching Magnifying Lens to Viewing Hood .....	51
<b>ELECTRICAL PARTS LIST.....</b>	<b>52</b>
<b>SCHEMATIC DIAGRAMS.....</b>	<b>S-1</b>

# SPECIFICATIONS

**1. Display** 6" diagonal CRT

**2. Echo Presentation** 4 different brightness.

LEVEL	STRONGEST		NO SIGNAL	
	3	2	1	0
Hue 0	BRIGHT	MEDIUM	DARK	BLACK
Hue 1	BRIGHT	MEDIUM	MEDIUM	BLACK
Bright Echo Mode	DARK	BRIGHT	MEDIUM	BLACK

**3. Basic Range**

Range No.	1	2	3	4	5	6	7	8
Meters	5	10	20	40	80	150	250	300
Feet	15	30	60	120	250	500	1000	1500
Fathoms	2.5	5	10	20	40	80	120	160

**4. Range Shift**

Display start depth can be shifted in 1M (FT, FA) steps up to 300M (1500FT, 160FA). The range shift function is disabled while the AUTO mode is selected.

**5. Bottom Lock Expansion Range**

Meters	Feet	Fathoms
3	10	10

**6. Auto Mode**

Automatically switches depth range and sensitivity depending on the depth of the water.

**7. Presentation Mode**

MODE	DISPLAY
NORM	Normal
B/L	Normal + Bottom-Lock Expansion (1/2 + 1/2)
B/Z	Normal + Bottom Zoom (1/2 + 1/2)
M/Z	Normal + Marker Zoom
NAV	Digital display of water depth, water temperature, ship's speed, L/L data

**8. Picture Advance Speed**

Setting	0	1	2	3
Lines/TX	Freeze	1/2	1/1	2/1



**9. Transmit Frequency/  
Output Power**

50 or 200kHz, 150Wrms

**10. Pulselength**

Range	Pulselength(ms)
0 -40m	0.2
41 - 80m	0.4
81 - 140m	0.6
141 - 200m	0.8
201 - 300m	1.6
301 - 600m	2.0

**11. Interference Rejector**

Rejects unwanted signals by comparing last and present echoes in strength

**12. Alarm**

Alarm sounds when echo stronger than yellow level comes into the alarm depth zone.

**13. Input/Output Data  
(NMEA #0183 Format)**

The FMV-605 permits data communication with navigational equipment and temperature indicator which have I/O port for NMEA0183.

Input:	Ship's position (L/L), Ship's speed (Sentence: RMA, RMB, RMC) Water temperature (Sentence: MTW)
Output:	Depth (Sentence: DBT)

**14. Environmental  
Condition**

Temperature: 0 - 50°C (Splash proof structure)

**15. Power Supply**

12Vdc or 24Vdc (24V PWR board should be incorporated), less than 25W.

**COMPLETE SET**

No.	Name	Type	Code No.	Qty
1	Display Unit	MV-605	See note.	1
2	Transducer	520-5PSC (Thru-hull, plastic)	000-015-109	1
3	Installation Materials	CP02-02700	000-014-799	1 set
4	Accessories	FP02-03400	000-014-800	1 set
5	Spare Parts	SP02-02100	000-024-730	1 set
6	Documents	Operator's Manual		1 set

**■ Note:**

Display unit code number changes with frequency (50kHz or 200kHz), power supply (12V or 24V), depth unit (meter, foot or fathom), temperature unit (°C or °F) and speed unit (knot or meter).

## INSTALLATION MATERIALS

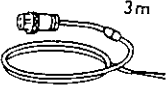
No.	Name	Type	Code No.	Qty	Fig.
1	Power Cable Assy	22S0023	000-109-516	1	1
1					

## ACCESSORIES

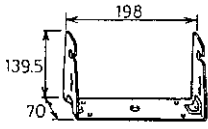
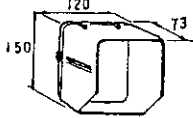
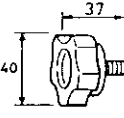
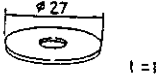
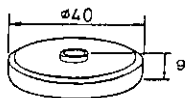
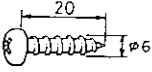
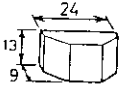
No.	Name	Type	Code No.	Qty	Fig.
1	Hanger Assy	22-017-1071-0	100-151-750	1	1
2	Viewing Hood	FP02-03410	001-378-780	1	2
3	Knob Bolt	KG-B2, M8x20	000-801-738	2	3
4	Knob Washer	05-012-0125	591-201-251	2	4
5	Rubber Washer	22-012-1302	100-101-130	2	5
6	Tapping Screw	6x20, SUS302	000-800-414	4	6
7	Rubber Vibration Isolator	22-017-1072-0	100-151-760	2	7
1					
2					
3					
4					
5					
6					
7					

## SPARE PARTS

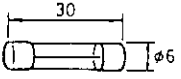
No.	Name	Type	Code No.	Qty	Fig.
1	Fuse	FGBO-A 3A AC125V	000-549-063	2	1
1					

## OPTION

No.	Name	Type	Code No.	Remarks
1	Transducer (Dual frequency transducer)	520-5PWC	000-115-414	Plastic
		520-MSC	000-115-416	Bronze
		520ST-PWA	000-015-417	with temp/spd sensor
		520ST-MSA	000-115-418	with temp/spd sensor
2	Speed/Temperature Sensor	ST-01PTB	000-019-503	
		ST-01PSB	000-019-504	Plastic
		ST-01MSB	000-019-505	Bronze
3	Temperature Sensor	T-02MTB	000-040-026	Transom mount
		T-02MSB	000-040-044	Plastic
		T-03MSB	000-040-027	Bronze
5	ST Sensor Bracket	OP02-30	001-358-850	For ST-01PTB
6	Kick-up Bracket	OP02-29	001-358-840	For 520-5PWC, 520ST-PWA
7	NMEA Cable	CP02-02320	001-358-810	
8	Flush Mount Kit	OP02-60	001-351-980	
9	Magnifying Lens	ES2	100-164-830	
10	Adhesive	OP02-31	000-013-634	For inside-hull mount
11	Rectifier	PR-62, 100VAC	000-013-484	
		PR-62, 110VAC	000-013-485	
		PR-62, 220VAC	000-013-486	
		PR-62, 230VAC	000-013-487	

## SYSTEM CONFIGURATION

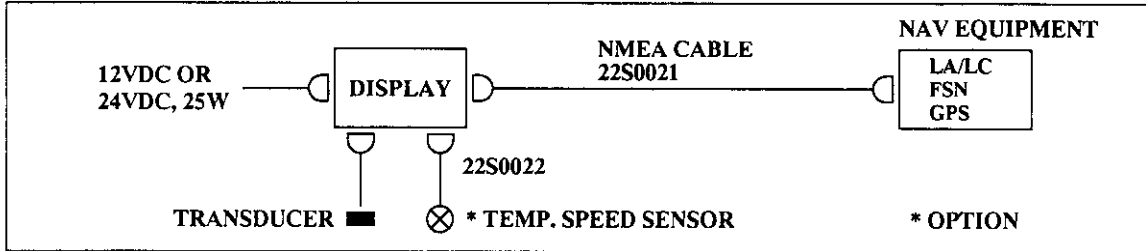

## TRANSDUCER MOUNTING METHOD

TRANSOM MOUNT	①	②	③
Transducer	520-5PWC/520ST-PWA		
Bracket (Option)	none		Kick-up Bracket 0P02-29
HULL BOTTOM MOUNT	④	⑤	
Transducer	520-5PSC or 520-5MSC	520-5PSC, 520-5MSB or 520ST-MSA	

## SPEED/TEMPERATURE MOUNTING METHOD

TRANSOM MOUNT	Ⓐ	Ⓑ	Ⓒ
	Sensor (Option)	ST-01PTB	
Bracket (Option)	Sensor Bracket 0P02-30	none	
HULL BOTTOM MOUNT	Ⓓ		
Sensor (Option)	ST-01PSB or ST-01MSB		

# PRINCIPLE OF OPERATION

The FMV-605 Video Sounder determines the distance between its transducer and underwater objects such as fish, lake bottom or seabed and displays the results on a 6" color screen. It does this by utilizing the fact that an ultrasonic wave transmitted through water travels at a nearly constant speed of 4800 feet (1500m) per second. When a sound wave strikes an underwater object such as fish or sea bottom, part of the sound wave is reflected back toward the source. Thus by calculating the time difference between the transmission of a sound wave and the reception of the reflected sound wave, the depth to the object can be determined. In a sense an echo sounder can be thought of as being an extremely sophisticated and quick timer, since it is capable of resolving time differences shorter than one thousandth of a second.

The entire process begins in the display unit. Transmitter power is sent to the transducer as a short pulse of electrical energy. The electrical signal produced by the transmitter is converted into an ultrasonic signal by the transducer and transmitted into the water. Any reflected signals from intervening objects (such as a fish school) are received by the transducer and converted back into an electrical signal. It is then amplified in the amplifier section, and finally, displayed on the screen.

The picture displayed by the FMV-605 is made up of a series of vertical scan lines, one for each transmission. Each line represents a "snapshot" of what has occurred beneath the boat. The series of snapshots are accumulated side by side across the screen, and the resulting contours of the bottom and fish between the bottom and surface are displayed. The amount of history of objects that have passed beneath the boat over a series of transmission varies from less than a minute to a few minutes, depending on how you adjust the unit. For further details, see page 23, Picture Advance Speed Selection.

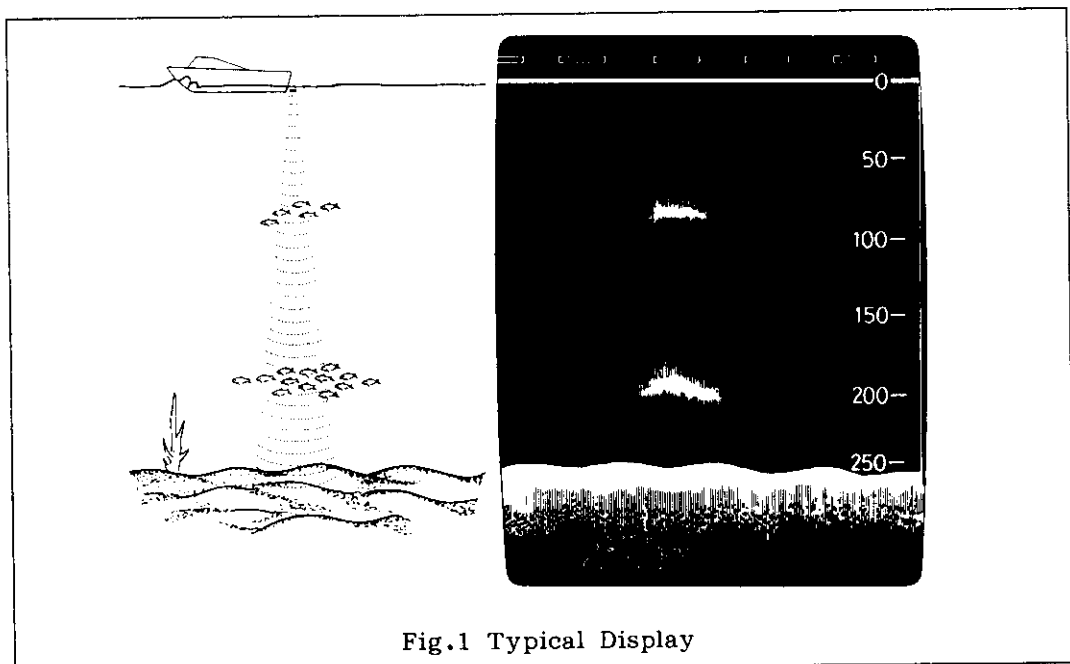

Fig.1 Typical Display

# 1. INSTALLATION

## 1.1 TRANSDUCER INSTALLATION

### Overview

The FMV-605 is available with either a transom mount, inside-hull mount or through-hull mount transducer. This section shows installation procedure for the through-hull and inside-hull mounts which can be performed with the standard supply transducer 520-5PSC and optional transducer 520-5MSC. For the transom mount installation, refer to "Installation of Optional Device" on page 44.

### Location

The performance of this video sounder is directly related to the mounting location of the transducer, especially for high-speed cruising. The installation should be planned in advance, keeping the standard cable length (8m) and the following factors in mind.

- Air bubbles and turbulence caused by movement of the boat seriously degrade the sounding capability of the transducer. The transducer should, therefore, be located in a position where water flow is the smoothest. Noise from the propellers also adversely affects performance of and the transducer should not be mounted nearby. The rifting strakes are notorious for creating acoustic noise, and these must be avoided by keeping the transducer inboard of them.

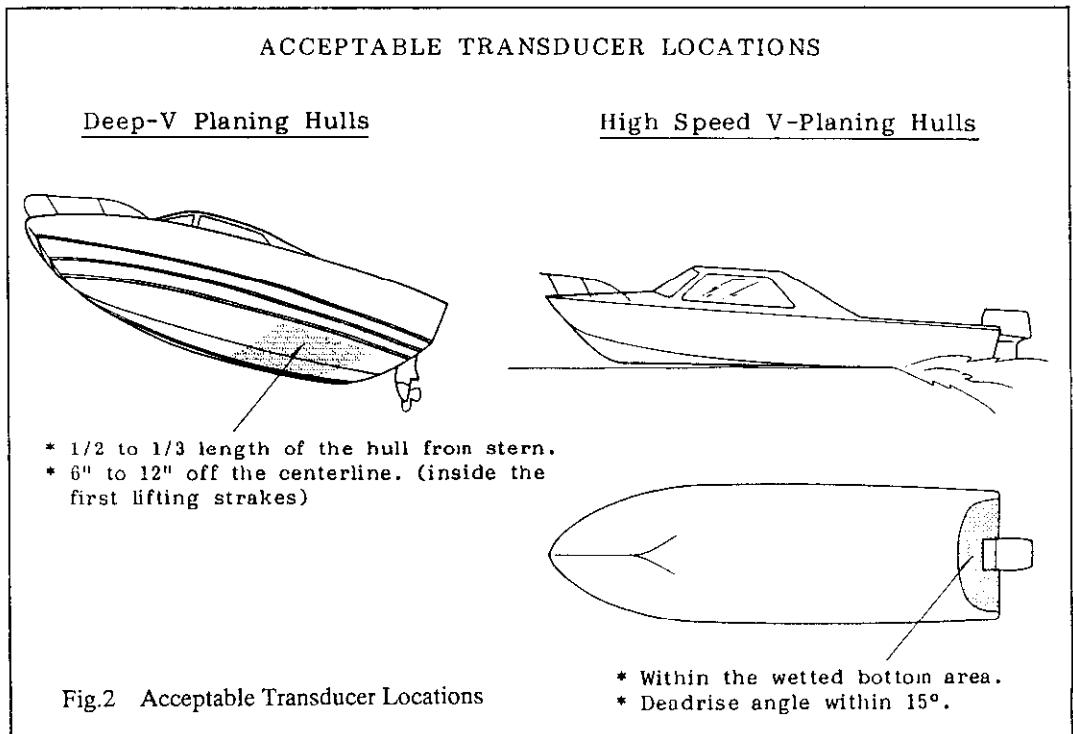

- The transducer must always remain submerged, even when the boat is rolling, pitching or up on a plane at high speed.
- For displacement hulls, using inside-hull and through-hull installations, a practical choice would be somewhere between 1/3 and 1/2 of the boat's length from the stern. For planing hulls, a practical location is generally rather far astern, so that the transducer is always in the water regardless of the planing attitude.

## Through-Hull Mount

### Overview

This type of mounting provides the best performance of all, since the transducer protrudes from the hull and the effect of air bubbles and turbulence near the hull skin is reduced. To determine the transducer location, keep in mind the general considerations described on page 7. Also when the boat has a keel, the transducer should be at least 30cm (1 foot) away from it. Typical through-hull mountings are illustrated in Fig.3.

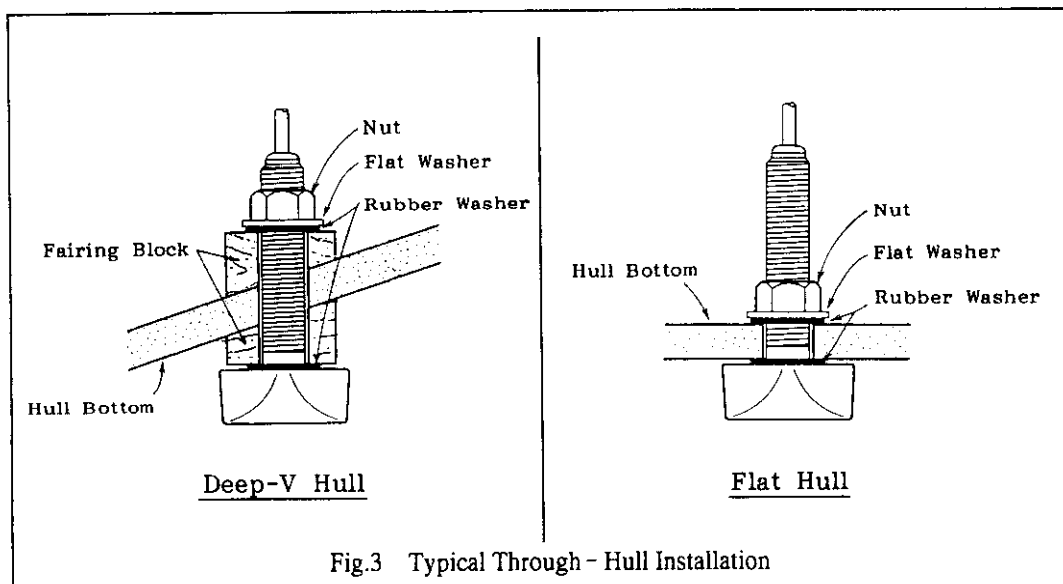

### Mounting Procedure

1. With the boat hauled out of the water, mark the location selected for mounting the transducer on the bottom of the hull.
2. If the hull is not level within 15 degrees in any direction, Fairing blocks made out of teak should be used between the transducer and hull, both inside and outside, to keep the transducer face parallel with the water line. Fabricate the fairing block as shown in Figure 4 and make the entire surface as smooth as possible to provide an undisturbed flow of water around the transducer. The fairing block should be smaller than the transducer itself to provide a channel to divert turbulent water around the sides of the transducer rather than over its face.

3. Drill a hole just large enough to pass the threaded stuffing tube of the transducer through the hull, making sure it is drilled vertically.
4. Apply a sufficient amount of high quality caulking compound to the top surface of the transducer, around the threads of the stuffing tube and inside the mounting hole (and fairing blocks if used) to ensure watertight mounting.
5. Mount the transducer and fairing blocks and tighten the locking nuts. Be sure that the transducer is properly oriented and its working face is parallel to the waterline. Do not over-stress the stuffing tube and locking nuts through excessive tightening, since the wood block will swell when the boat is placed in the water. It is suggested that the nut be tightened lightly at installation and retightened several days after the boat has been launched.

**■ CAUTION**

*The tightening torque should not exceed 400kg-cm. Excessive stress will cause damage to the threads of the plastic stuffing tube.*

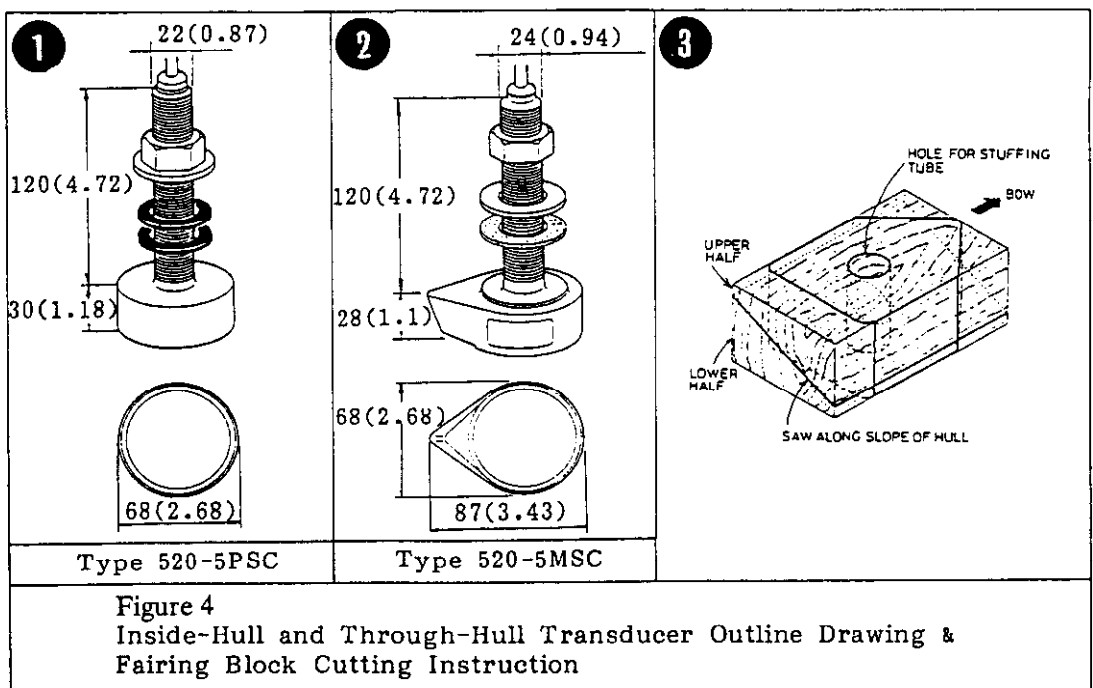



# Inside-Hull Mount

## Introduction

While this is by no means an optimum mounting scheme for deep-water sounding, this type of mounting can sometimes be used on fiberglass boats. A transducer can be likened to an antenna used with a TV set. Mounting an antenna inside your attic is like mounting an echo sounder transducer inside the hull. Both will work well enough, but are hardly optimum for either TV or echo sounder operation.

## Mounting Location

In addition to the general considerations described on page 7, it is important to ensure that the transducer be placed in an area that has a single-hull thickness and is void of air or flotation materials other than solid fiberglass between the transducer face and the water. Also, the transducer face should not be placed over hull struts or ribs which generally run under the hull. Further, a location where the rising angle of the hull exceeds  $15^\circ$  should be avoided to minimize the effect of the boat's rolling.

It is advisable that the mounting location be finalized through a little trial and error after all other installation works have been completed. Temporarily put some silicone grease (not the type that sets up after drying!) inside the hull. Push the transducer down to squeeze out any air bubbles. Turn on your unit. Run the boat at various speeds and move the transducer to different locations to select the position where the best picture is obtained. Once a good location is found, you may permanently mount the transducer.

The inside-hull mounting is accomplished as follows. See figure 4 for outline drawing.

## Mounting Procedure

1. Lightly roughen the transducer face with fine #10 sandpaper and degrease it with a solvent (thinner or alcohol). Also, roughen and degrease the inside of the hull where the transducer is to be mounted.

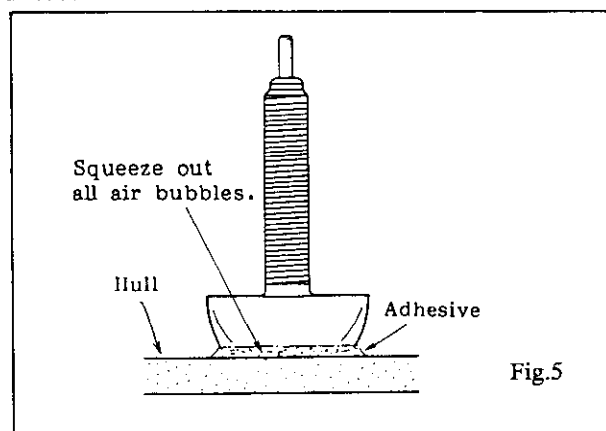

2. Allow both to dry completely, then coat the transducer face and hull with the adhesive supplied. In a cold environment, you should warm the adhesive to approximately 40°C before usage to soften it.
3. Press the transducer firmly down on the hull and gently twist it back and forth to remove any air which may be trapped in the adhesive. Allow sufficient time for the adhesive to dry.

**■ IMPORTANT**

**When the inside-hull mounting is used, jumper wire JP10 on the MIN board should be cut off. See page 43. This will increase the receiver gain to offset loss of signal in the fiberglass hull.**

## **Transducer Preparation and Painting**

Just prior to putting your boat into the water, the face of the transducer should be thoroughly wiped with a detergent liquid soap. This will lessen the time necessary for the transducer to establish good contact with the water. Eliminating this will lengthen the time required for complete "saturation" and will reduce the performance of the unit.

To maintain the sensitivity of the transducer, do not coat the face with heavy pigmented antifouling paints, i.e. , cuprous oxide types. Use only a light, thin coat of a vinyl based antifouling paint, like International Paint's TRI-LUX No.67 or No.68.

## 1.2 DISPLAY UNIT INSTALLATION

### Mounting

#### Mounting Location

The display unit is carefully constructed to be able to withstand the humidity and corrosive atmosphere common in the marine environment, but it is not designed to be used outside, directly exposed to that environment. Salt water splash will most assuredly cause damage to the sensitive components inside. Keep these and the following factors in mind when planning the installation of the display unit.

#### ■ CAUTION

*Furuno will assume no responsibility for the damage caused by exposure to either fresh or salt water.*

- The display unit consumes very little power, so there is no need of forced air ventilation. However it is necessary to provide at least some circulation of cooling air by allowing sufficient space around the unit.
- The display unit must be mounted inside an enclosed cabinet, completely shielded from salt water spray, and from fresh water spray if the boat is usually hosed down after a day's outing. Most small center console boats are equipped with such an enclosed cabinet behind the wheel, and most have clear doors so that equipment may be seen behind them.
- Consideration should be made to provide space for access to the mounting hardware on the side and connectors behind the display unit. Also allow at least a foot or so of service loop in the cables to allow the unit to be pulled forward for servicing or internal adjustment.

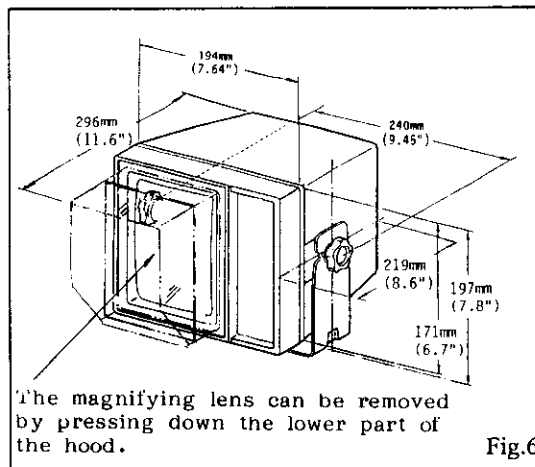

- Even though the picture is quite legible even in direct sunlight, it is recommended to keep the display unit out of direct sunlight or at least shaded because of heat that can build up inside the cabinet.
- The display unit can be mounted on either a table-top, bulkhead or overhead. Make sure that the selected location is strong enough to support the unit under the conditions of continued vibration or shock which will be normally encountered on the boat. If necessary, appropriate reinforcement measures should be taken in the mounting area.
- The display unit should be mounted apart from equipment(s) emitting heat. Also, do not put thing(s) on the toe of the unit.

## Mounting Display Unit using Bracket

The display unit can be mounted as follows on a table-top, bulkhead or overhead by using the bracket supplied as standard.

1. Mark the screw locations by using the bracket as a template.
2. Drill four pilot holes for the bracket.
3. Install the bracket by using the screws supplied.
4. Fit knobs, rubber washers and knob washers to the display unit,
5. Install the display unit in the bracket. Tighten the knobs securely.

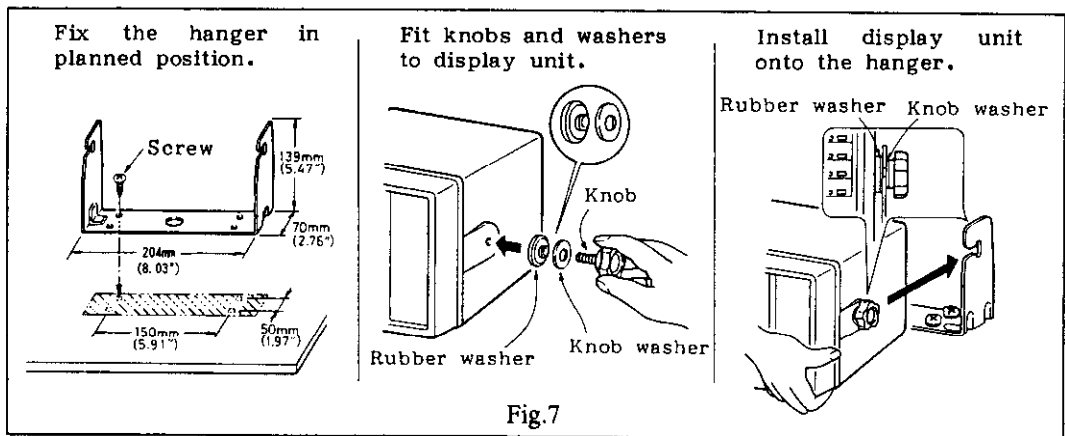

Fig.7

## Mounting Display Unit using Optional Flush Mount Kit

Many owners will undoubtedly use the FMV-605 on small boats, many with center consoles and wish to mount flush with console panels. It is recommended that the optional flush mount kit OP02-60 be used for this purpose. Detailed installation procedure is shown on page 49.

## Installation of Rubber Vibration Isolator

The rubber vibration isolators stabilize the display unit against ship's vibration. When a strong vibration is expected, attach it to the bracket as follows.

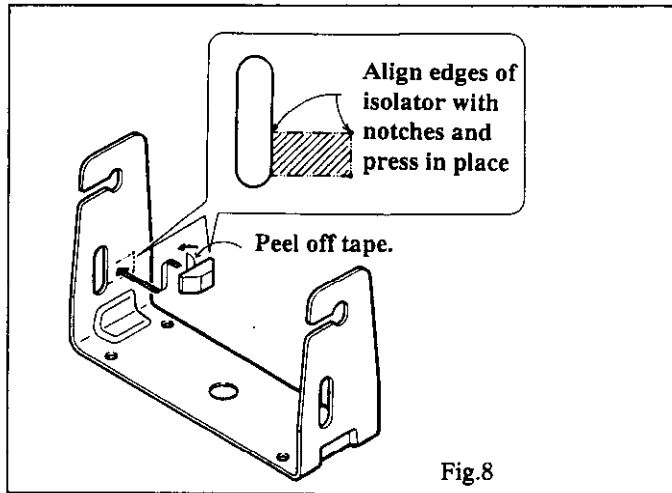

## Cable Connections

Cable connections to the FMV-605 display unit are made at the connectors located at the rear of the unit. Fig.9 shows the wiring instructions.

### Transducer Cable Connection

In order to minimize the chance of picking up electrical interference, avoid where possible routing the transducer cable near other on-board electrical equipment. Also avoid running the cable in parallel with power cables.

### Power Cable Connection

The FMV-605 is designed to operate normally at a voltage between 11 and 16Vdc for 12V set or between 20 and 32Vdc for 24V set. The power should be directly taken from the distribution board or breaker panel.

Connect the red lead of the cable to the positive (+) terminal of the battery and the black lead to the negative (-) terminal.

### ■ CAUTION

*Reversing the polarity will result in blowing the fuse and may very well damage internal components*

### Connection to Position Fixing Equipment

To connect the FMV-605 with the position fixing equipment, the NMEA cable assembly is optionally required. The contents of the assembly are as follows.

No.	Name	Type	Qty
1	NMEA Cable	22S0021	5m
2	Connector	SRCN16-10P	1
3	Rubber Bush	02-073-2001-0	1

The FMV-605 can accept NMEA #0183 format data with sentences RMB, RMB, RMC and DBT. Connect the yellow and green leads of the cable to the signal and return lines of the position fixing equipment respectively.

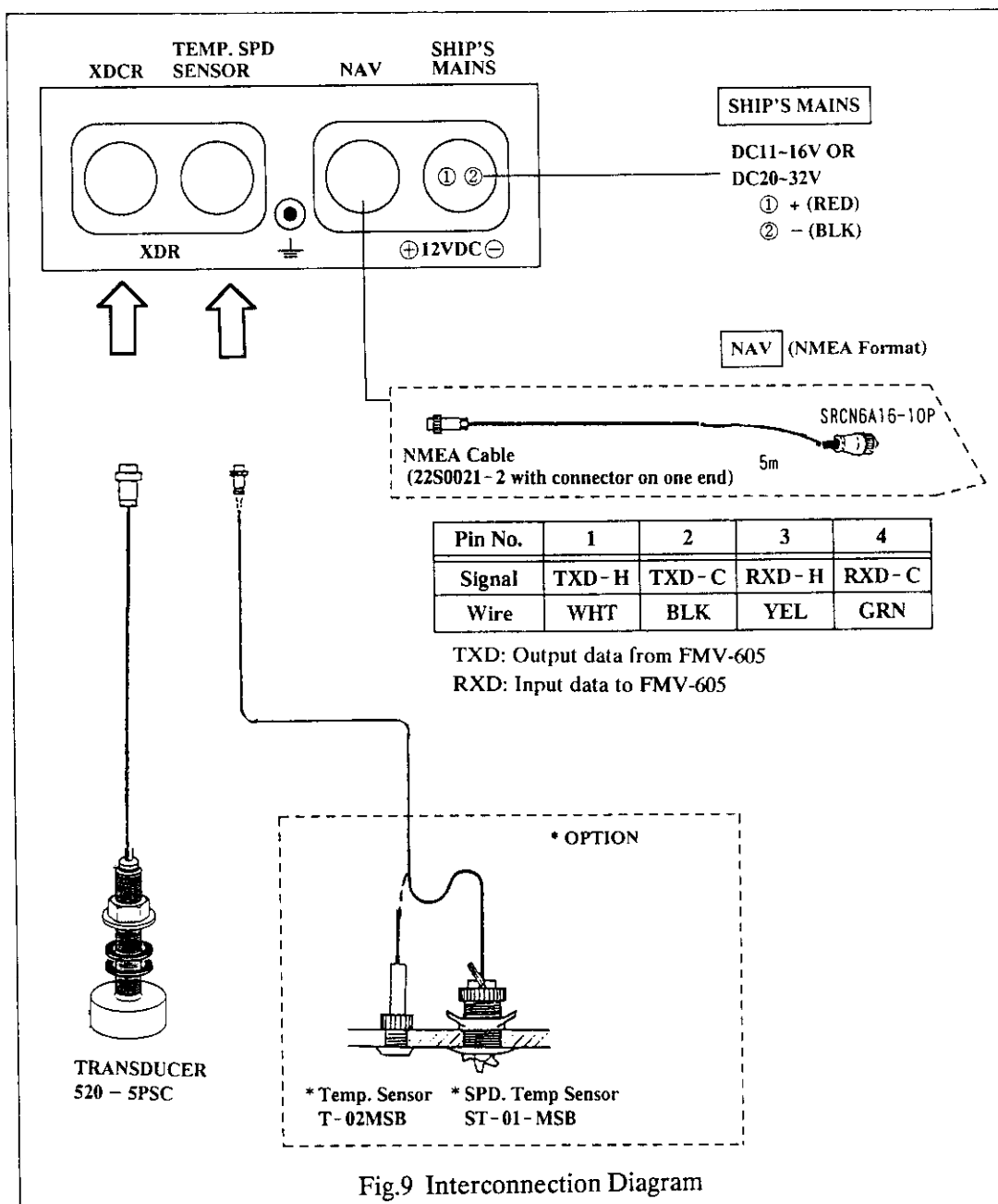

Fig.9 Interconnection Diagram

## **Grounding**

The FMV-605 is designed to operate normally without grounding the display unit, provided that the cable routing precautions stated before are taken. However in some cases, interference may show up at high gain settings, and it may become necessary to ground the unit to the boat's grounding bus to eliminate the problem. In such cases, run a heavy duty ground wire from the grounding terminal on the rear bottom of the display unit to the nearest grounding point on the boat.

On a fiberglass boat, it is best to install a ground plate that measures about 20 cm by 30 cm (0.8 feet by 1.0 feet) on the outside of the hull bottom to provide a ground point. If this is not practical, the engine block can be used.

## 2. OPERATION

### 2.1 BASIC OPERATION

#### Introduction

The equipment is so designed that even a first time user can quickly become acquainted with the operating procedure. Pressing of each touchpad key is acknowledged by a beep sound, and keying sequence is smartly organized and acknowledged by alphanumeric/symbolic indicators on the screen.

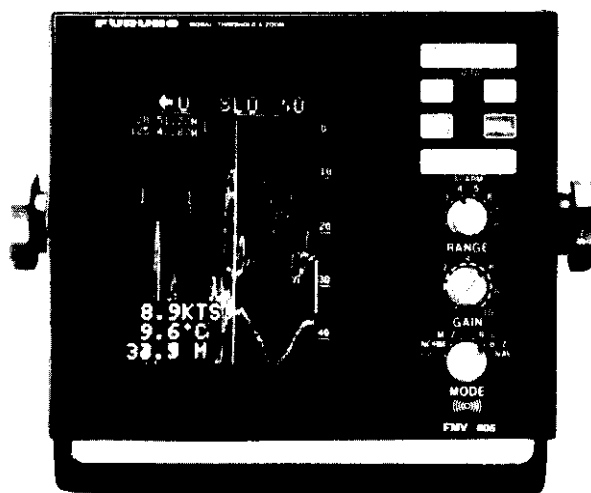

KEY/KNOB	FUNCTION
SHIFT	Sets the display start depth of the picture.
ADVNC	Selects the picture advance speed.
HUE	Determines the background color of the picture.
SIG LEV	Eliminates low intensity echoes in four steps up to yellow color echoes.
BRILL	Adjusts picture brilliance.
MARKER	Moves the zoom/alarm activation bar up to your desired position. (The width of the bar is prefixed according to the range in use.) Turns on/off the alarm when the two keys are pressed simultaneously.
RANGE	Sets the basic range of the picture.
GAIN	Adjusts picture sensitivity.
MODE	Turns on/off the unit and sets presentation mode. NORM: Normal picture M/Z: Normal + Marker Zoom pictures B/L: Normal + Bottom-lock Expansion pictures B/Z: Normal + Bottom Zoom pictures NAV: Navigation data display



## Power ON/OFF

Power is supplied to the unit by turning **MODE** switch clockwise until a click sound is heard. Note that there is a 6-10 sec. delay prior to display of the picture while the CRT warms up. Every time the equipment starts with the previous settings before turning off. To turn off the unit, turn **MODE** switch fully counterclockwise to "OFF" position.

## Brilliance Control

Press **BRILL** key to adjust the picture brilliance. It can be adjusted in three steps. To extend the life of the CRT, do not unduly increase the brightness of the screen.

## Presentation Mode Selection

Five presentation modes are available and you may select one of them with **MODE** switch.

MODE	FUNCTION
NORM	displays normal picture on full screen.
M/Z	displays normal picture on the right half and marker zoom picture on the left half of the screen.
B/L	displays normal picture on the upper 2/3 and bottom-lock expansion picture on the lower 1/3 of the screen.
B/Z	displays normal picture on the right half and bottom zoom picture on the left half of the screen.
NAV	displays navigation data such as ship's position (L/L), ship's speed, water temperature on full screen.

### Marker Zoom (M/Z) Presentation

This mode expands anywhere of the normal picture to full vertical size of the screen on the left half window of the screen. You may specify the portion to be expanded with **ALARM** [-] or [+] key. The white vertical bar on the right of the normal picture indicates the portion to be expanded. The length of the bar normally changes

with range setting in use but fixed at 20ft (5m, 4fa) long when the GAIN control is set to "AUTO".

■ **NOTE:**

- The marker zoom does not work on ranges "1" and "2".

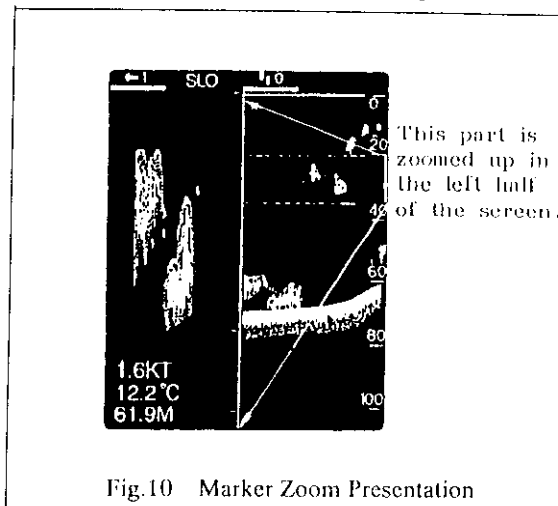

Fig.10 Marker Zoom Presentation

**Bottom-Lock Expansion Presentation**

Selecting the "B/L" mode provides a compressed normal picture on the upper 2/3 of the screen and a 10ft (3m, 2fa) wide layer in contact with the seabed is expanded onto the rest of the screen with the seabed contour aligned. The range of expansion can be easily recognized on the normal picture because it is marked with a bright line as illustrated below. This mode of presentation offers an excellent bottom fish discrimination which is indispensable for bottom trawling.

For the bottom lock expansion presentation, the seabed contour must be steadily and distinctly plotted with the BRIGHT intensity. Adjust the Gain for the best seabed presentation. Too high a setting in shallow water may cause heavy surface noise that reaches the seabed, causing erratic bottom lock operation.

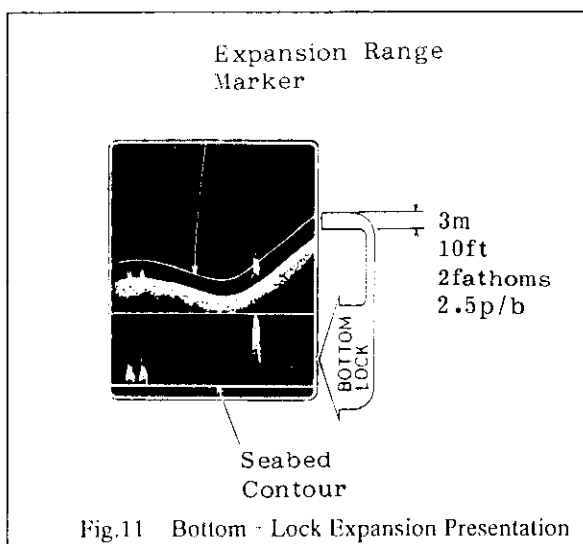
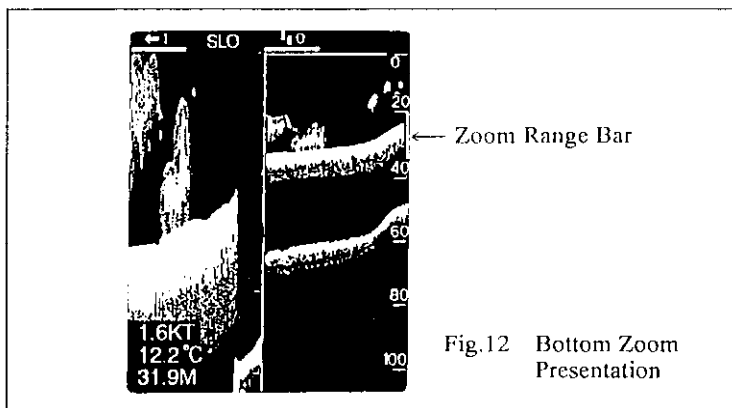

Fig.11 Bottom Lock Expansion Presentation

## Bottom Zoom (B/Z) Presentation

This mode expands bottom and bottom fish echoes 4 to 6 times to full vertical size of the screen. The zone expanded is indicated by a white vertical bar on the right of the normal picture display. The length of the bar normally changes with the range setting in use.

The zone automatically moves so that the bottom echoes are located on the lower half screen. It jumps up when the bottom echoes come to the center of the bottom zoom display and jumps down when they reach the lower edge of the display.



This mode may be advantageous for observing hardness of the bottom closely in addition to bottom fish. Many fishermen find the place where bottom fish are likely to be, from the shape of bottom profile and length of tail of bottom echoes. Some fish may live on soft sandy bottom which is displayed with short tails and some fish on hard bottom displayed with long echo tails. In addition, as you become acquainted with this mode, you may find a small school of bottom fish which may be overlooked even on the bottom-lock expansion picture

## Navigation Data (NAV) Presentation

On this NAV screen, the navigation data are digitally displayed on the entire screen as shown below. Note however that, to display water temperature, ship's speed and ship's position, the optional sensor device or the position fixing equipment should be connected.

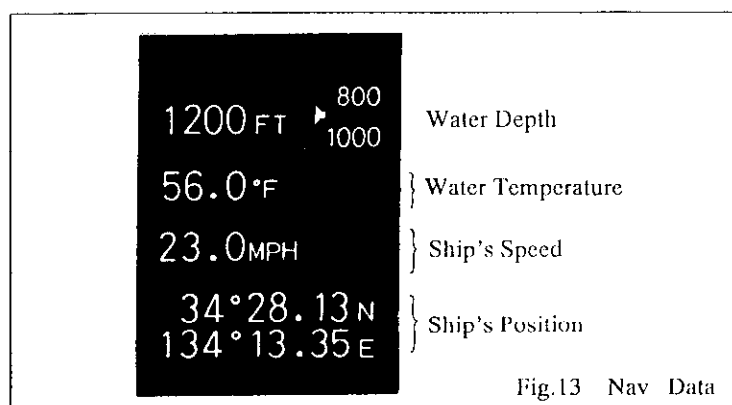

# Normal Picture Range Selection

## Introduction

The Basic Range and Range Shifting function used together give the operator the means to select the depth he can observe directly under the boat. The Basic Range can be thought of as providing a "window" into the water column. The start of this window is determined by the setting of the Shift Range selection. For example, if you select Basic Range "5", you will have a 250 foot deep viewing area, which may be moved anywhere in the water column by using the Range Shifting function. To continue our example, if the shift range is set to 50 feet, the top of the range window would be at 50 feet, and the bottom of the range window would be at 250 plus 50 feet or 300 feet.

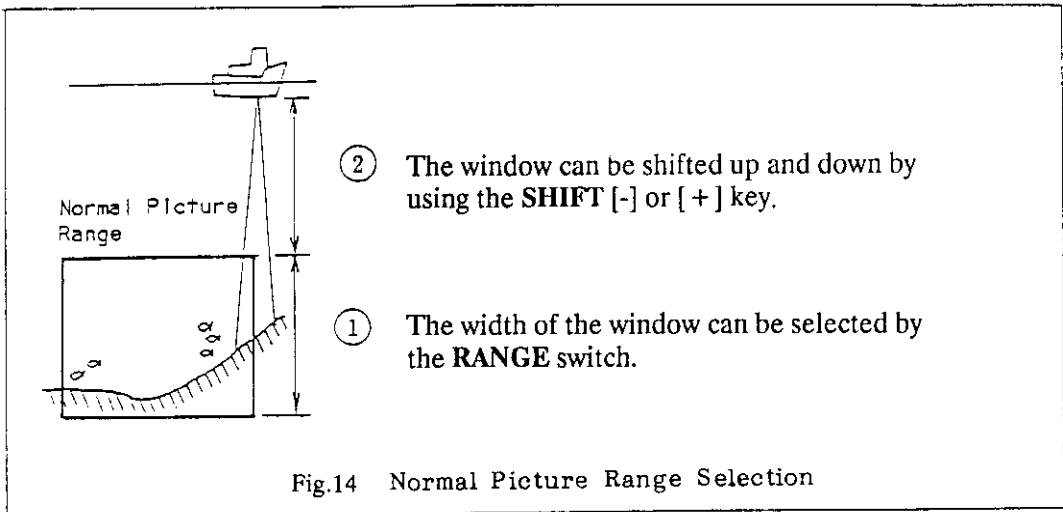

## Basic Range Selection

The Basic Range is selected with **RANGE** switch from 8 ranges shown in the table.

Range No.	1	2	3	4	5	6	7	8
Meters (M)	5	10	20	40	80	150	250	300
Feet (FT)	15	30	60	120	250	500	1000	1500
Fathoms (FA)	2.5	5	10	20	40	80	120	160

## Range Shifting

The basic range (window) selected may be shifted up and down by pressing **SHIFT** [-] or [+] key. The amount of range shifting, e.g., the depth at the upper limit of the window, is digitally indicated at the top right corner of the screen with the "■" symbol. Step of range shifting with the [-] or [+] key differs with respect to the key touch, i.e., one press for 1 foot step and keep pressing for 10 foot step.

■ **NOTE**

When the *GAIN* control is set to *AUTO*, the manual range setting mentioned above is not operative.

## Gain Control Setting

The *GAIN* control adjusts the sensitivity of the receiver. Normally, the gain is set to the point just below where excessive noise appears on the screen. As a general rule of thumb, use a higher gain setting for greater depths and a lower setting for shallower waters.

For example, if you are looking for fish between the surface and the bottom, you may not be concerned at all with seeing the bottom. You would bring up the gain until excessive noise is shown between the surface and bottom and then you would back off just a little. Now fish will show when they are encountered. As another example, if you are interested in seeing fish close to or on the bottom, you would bring up the gain until the bottom is shown in the strongest echo, *BRIGHT* intensity, and then increase the gain a bit further until excessive noise appears on the screen. Again you would back off the gain until the noise just disappears. In both of these cases you are setting up the maximum level of usable gain, assuring you of the greatest possibility for seeing fish.

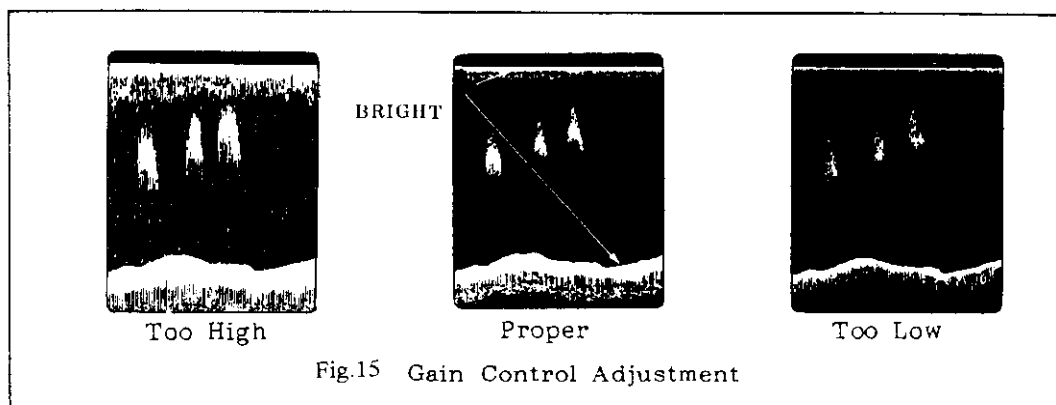

Fig.15 Gain Control Adjustment

## AUTO Mode

In the *AUTO* mode, the gain and the range scale are automatically selected. You may use this function virtually all the times. How it actually works is as follows;

- 1) Range changes automatically to locate the bottom on the lower half of the screen. It jumps to one step shallower range when bottom echoes reach  $\frac{2}{5}$  of the full scale from the top and to one step deeper range when they come to the lower edge of the scale.

2) The gain suitable to the range in use are automatically selected.

■ **NOTE**

- *The AUTO function stops working when bottom echoes becomes weaker than red level. In this case, the manual gain setting should be used.*
- *It also stops working when bottom echoes goes deeper than 300m; the range is fixed at 300m.*

## Picture Advance Speed Selection:

### Overview

Because the picture is built up one scan line at a time, from right to left across the screen, the amount of history displayed on the screen is directly related to the picture advance speed. At the fastest advance speed "3", each transmission results in two scan lines being produced on the screen. With the slowest advance speed "1", you will only see one scan line produced for every two transmissions. This will result in a longer amount of history being shown on the screen.

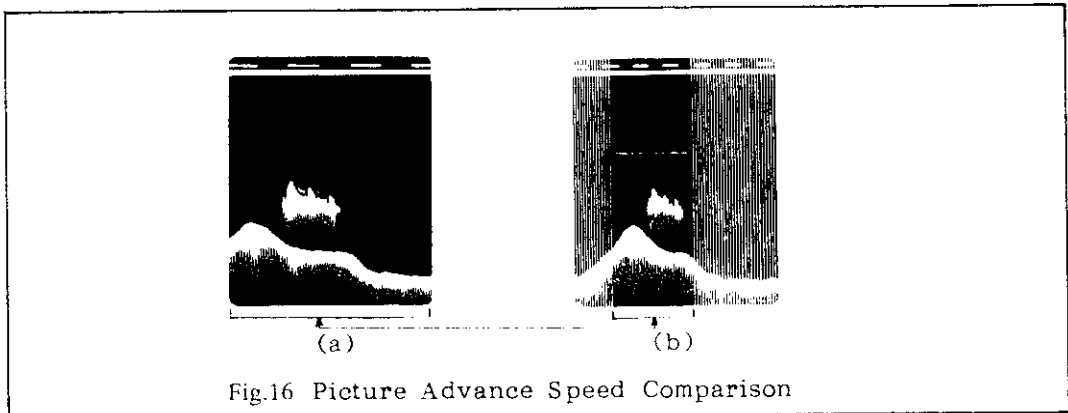

The fractions in the table below correspond to how many transmissions are necessary to construct one scan line. For example, if the Picture Advance Speed is set to "3" (fastest), with a Basic Range setting of "1", and a Shifted Range setting of 0 feet, an echo will remain on the screen for approximately one minute.

If the advance rate is set to "0", the display will remain frozen indefinitely.

Item Indicator	0	1	2	3
Scan Line/Transmissions	Freeze	1/2	1/1	2/1

## Guideline

When selecting an advance speed, keep in mind the following guideline.

- 1) At faster advancement speeds, care should be taken not to misjudge the size of the fish school; a fast advance speed will expand the size of the school horizontally across the screen.
- 2) A slower advance rate however will contract the size of the school across the screen.

## Signal Threshold Selection (SIG LEV Key)

When you wish to display echoes above certain level or wish to eliminate a small noise on the screen, press the **SIG LEV** (signal level) key. Every pressing eliminates the weakest color echoes on the screen up to **MEDIUM** level echoes.

## Selecting Echo Brightness Gradation (HUE Key)

The FMV-605 normally displays echoes in three different brightnesses. However, when it is used in the bright environment, especially at outdoors, the third gradation (**DARK**) echoes may be hardly visible. In that case, press **HUE** key, and the **DARK** echoes change to the **MEDIUM** level brightness.

**Bright Echo Mode** In addition to above, the Bright Echo mode is also selected with **HUE** key. It displays echoes with the brightnesses shown in the table below and is often used for discriminating fish lying just above the bottom. When the fish are close to the bottom, the two traces will merge and the fish trace will be indistinguishable from that of the bottom. The Bright Echo mode can be used in this situation. It is most effective when the bottom is rocky and hard since the difference in echo strength from the bottom compared to fish is large. On mud, seaweed-covered, or sloping bottoms, where the echo differential is less, the benefit in using the Bright Echo feature will be less pronounced.

LEVEL	STRONGEST ←→ NO SIGNAL			
	3	2	1	0
Hue 0 (Normal)	BRIGHT	MEDIUM	DARK	BLACK
Hue 1	BRIGHT	MEDIUM	MEDIUM	BLACK
Bright Echo Mode	DARK	BRIGHT	MEDIUM	BLACK



## 2.2 ADVANCED OPERATION

### Selecting Display Data (SHIFT Key)

Pressing the [-] and [+] of the **SHIFT** key simultaneously provides the numeric data and temperature graph on the echo sounder screen in the following sequence. The numeric data includes ship's L/L position, speed and temperature.

		Every pressing of <b>SHIFT</b> [-] and [+] changes the displayed data as follows.				
Indica- tion	DATA: GR:	ALL ON	ALL OFF	TMP ON	TMP OFF	OFF FF
L/L Data		<input type="radio"/>	<input type="radio"/>			
Speed Data		<input type="radio"/>	<input type="radio"/>			
Temp Data		<input type="radio"/>	<input type="radio"/>	<input type="radio"/>	<input type="radio"/>	
Temp Graph		<input type="radio"/>		<input type="radio"/>		

O: displayed

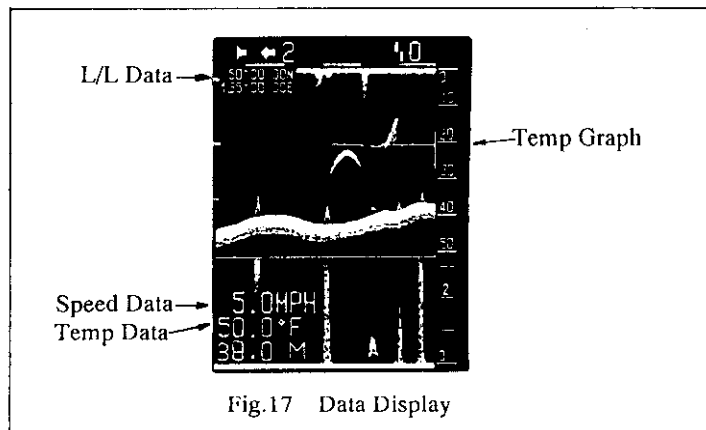

## Using Alarm Function

### Introduction

The alarm function alerts the operator of fish and seabed entered into the specified alarm zone. The alarm sounds and the "▶" symbol on the upper left of the screen is highlighted while releasing the alarm.

### Procedure

To activate the alarm function, press the **MARKER** [+] and [+] simultaneously. The "▶" symbol will appear on the upper left of the screen to indicate that the alarm function is now on.

The alarm zone is indicated by a white vertical bar on the right of the screen. Press the **MARKER** [ + ] or [ - ] to move it to the desired position.

To turn off the alarm function, press the **MARKER** [ + ] and [ - ] simultaneously.

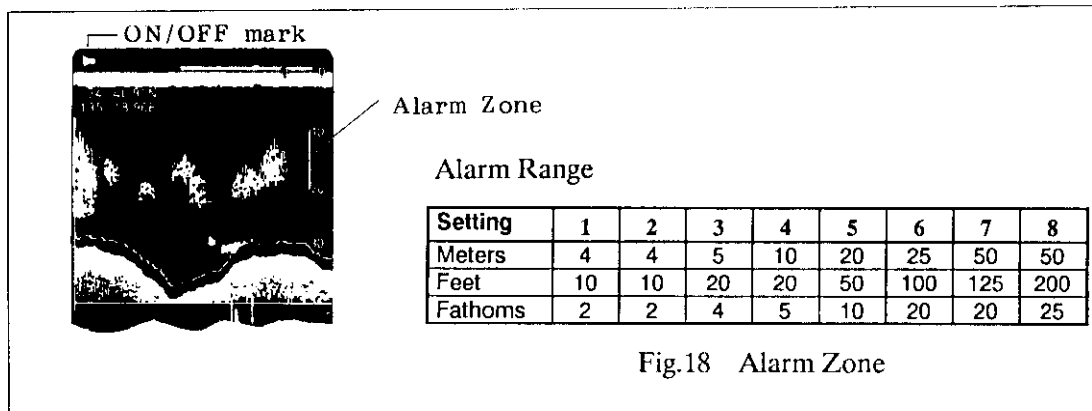

Fig.18 Alarm Zone

#### ■ NOTE

- The alarm zone is fixed at 5m (20 feet, 4 fathoms) long when the **GAIN** control is at **AUTO** position.
- Echo with a weak level can not trigger the alarm: the echo must be plotted with **MEDIUM** or **BRIGHT** intensity.
- An echo which is plotted within 1m from the zero line can not trigger the alarm.
- To move the alarm zone from the normal picture area to the bottom lock expansion picture area or vice versa, keep on pressing the **MARKER** key. The alarm zone marker stops for about one second at the boundary of two areas and then enters into the other area.
- The alarm function is disabled in the **Bottom Zoom (B/Z)** mode.

## Compensating Water Temperature Indication

An error in the water temperature indication can be compensated with the **SHIFT** [ - ] and [ + ] key up to  $\pm 5^{\circ}\text{C}$  (or  $10^{\circ}\text{F}$ ) in  $0.1^{\circ}$  steps.

Set the **MODE** switch to **NAV** and press **SHIFT** [ - ] to decrease the indicated temperature and [ + ] to increase it. The compensation value is displayed on the right of the **NAV** screen, and it disappears after a few seconds when the key is released.

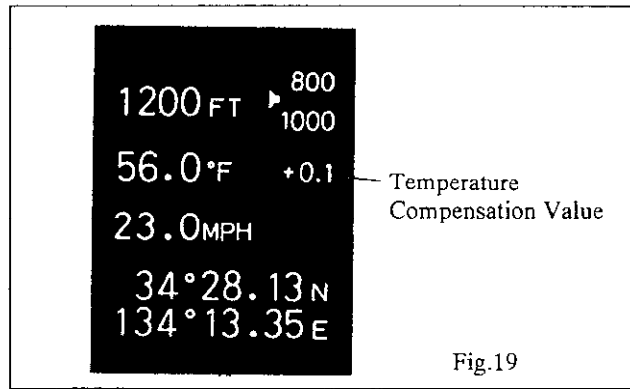

Fig.19

■ **NOTE**

- *The water temperature measured with the temperature sensor can be compensated but that fed from the navigation equipment can not.*

## Compensating Ship's Speed Indication

An error in the ship's speed indication can be compensated with the **ADVNC** and **SIG LEV** keys up to  $\pm 30\%$  in 1% steps.

Set the MODE switch to NAV and press **ADVNC** key to decrease the indicated temperature and **SIG LEV** key to increase it. The compensation value is displayed on the right of the NAV screen, and it disappears after a few seconds when the key is released.

■ **NOTE**

- *The ship's speed measured with the speed sensor can be compensated but that fed from the navigation equipment can not.*

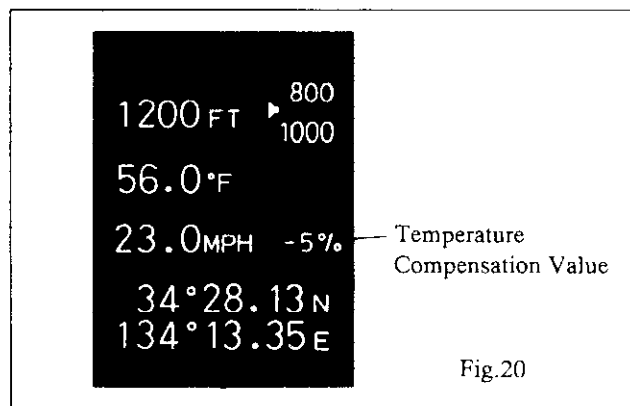
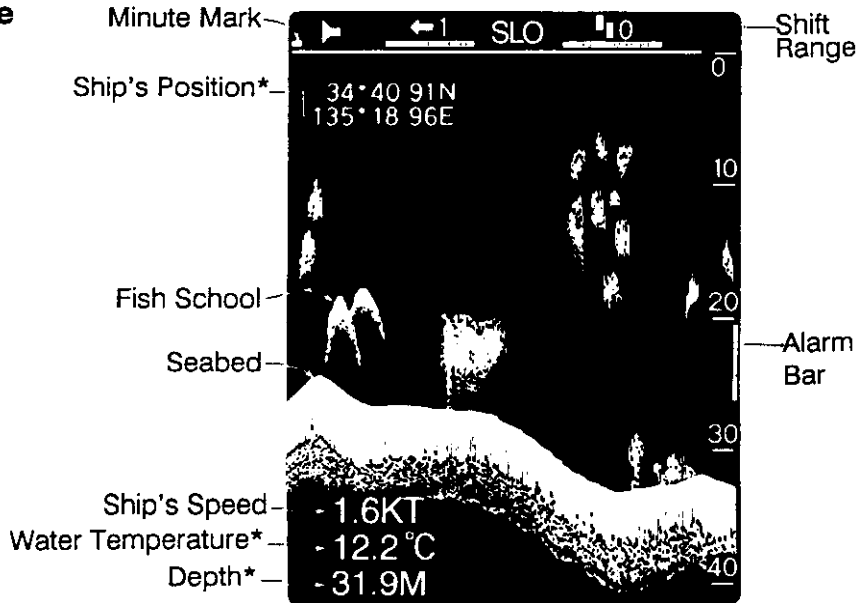

Fig.20

## 2.3 INDICATOR

### Echo Sounder Picture

#### Normal Mode



\* Position fixing equipment or temperature/speed sensor is required.

#### Normal + Bottom Lock (B/L) Expansion Mode

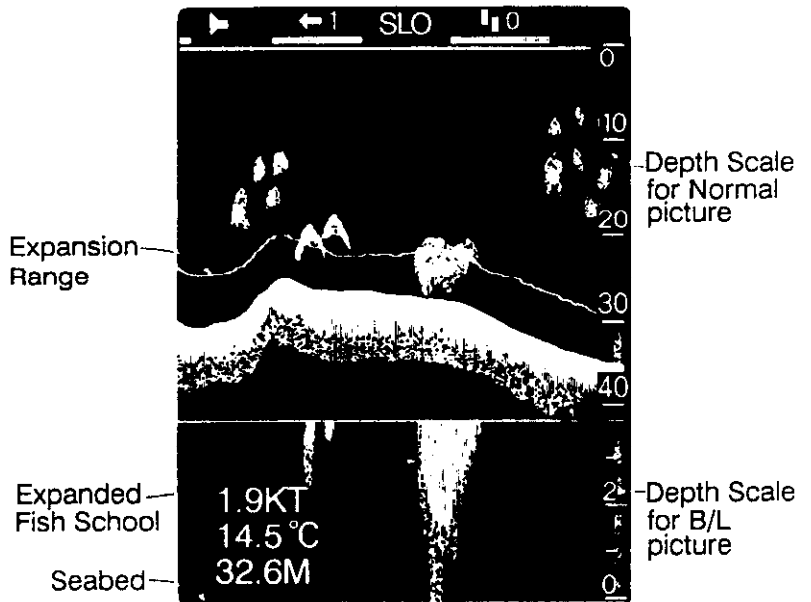

EE910719 - 02U

**Normal + Marker  
Zoom (M/Z) Mode**

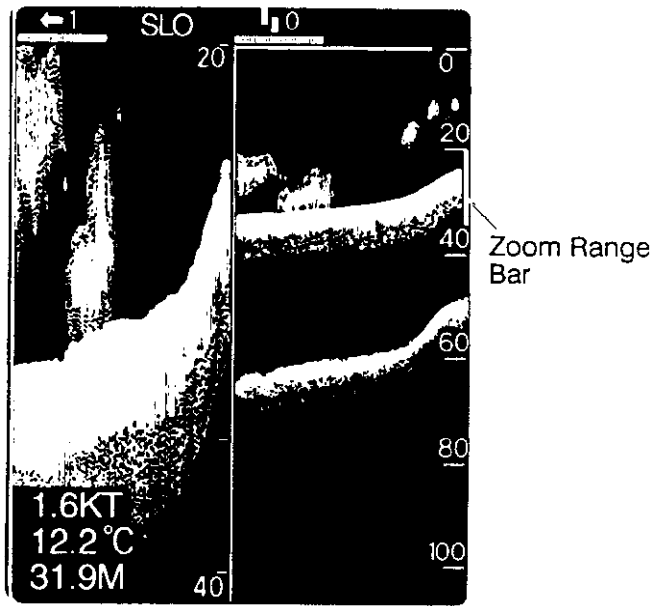

EE910719 - 03U

# Utilizing Water Temperature Indication

All fish species have their respective habitable water temperature ranges as shown below. By reading the water temperature indication, you can know if the water suits the fish you are aiming at. If the temperature is far out of the range, you can hardly expect a good catch.

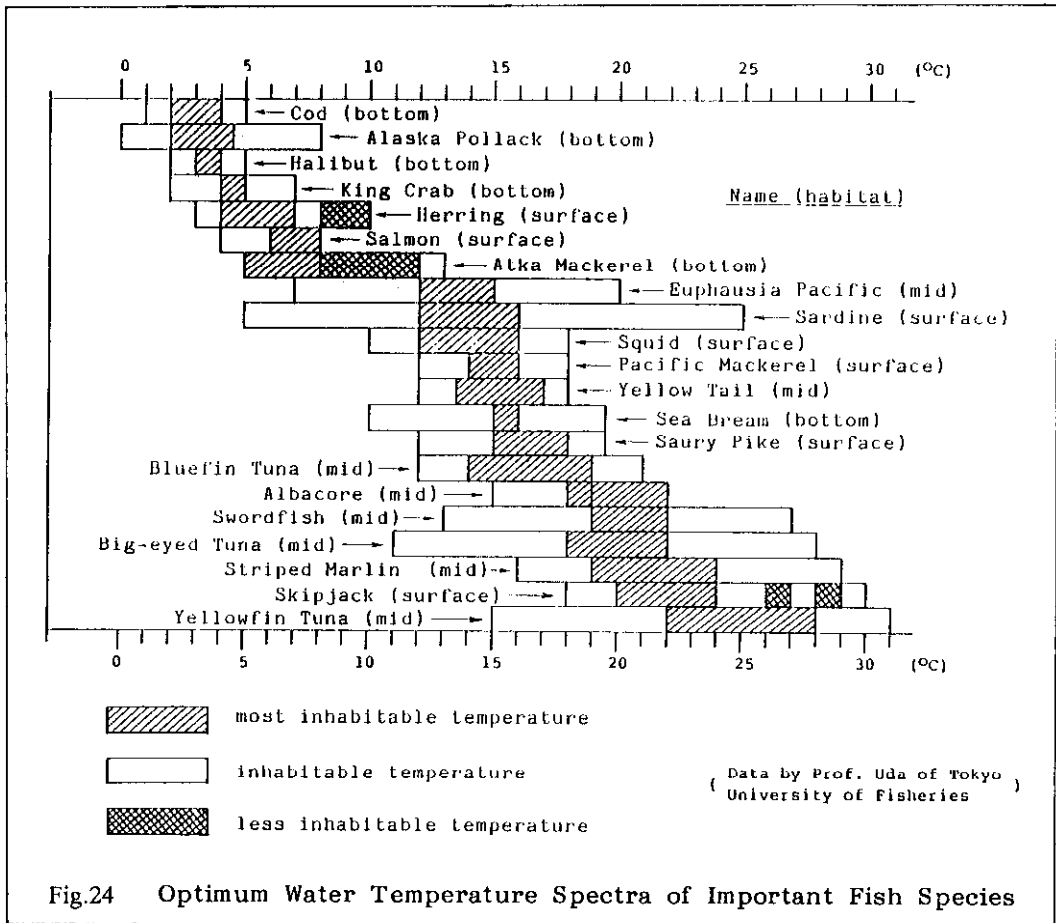

■ **NOTE:**

• For water temperature indication, an optional sensor device is required.

## Reading Water Temperature Graph

When the temperature graph is turned on by the **SHIFT** key (refer to page 26), the temperature graph is plotted on the upper part of the echo sounder picture.

The temperature plotting area is 5°C (10°F) wide and the temperature graph changes as follows.

• When the temperature graph is turned on, it is plotted at the center of the plotting area and afterwards it follows changes.

- If the temperature rises or falls to the limits of the plotting area, i.e., if the temperature changes by 2.5°C (5°F), the graph is shifted to the center of the plotting area.

As you will see from above function, only the change of the temperature can be read from the graph. You may use it to find the current rip\*.

\*It is well known that current rips, caused along sea streams/currents or at their junction, often gather dense fish schools. This rip can be found by watching air bubbles or coloration of sea surface, or by observing DSL (plankton layer) on the echo display. However, it is more reliable and easier to detect it by sudden changes of water temperature on the graphic data Logging mode.

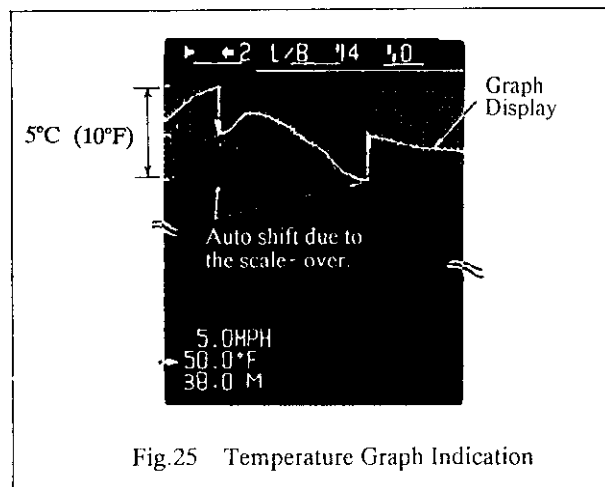

# 3. INTERPRETING THE DISPLAY

As mentioned before both fish echoes and bottom contour echoes are composed of a series of vertical scan lines moving right to left across the screen. It is possible for the same object to be recorded on the display with a variety of shapes depending on the distance to the object, the angle at which the object is struck by the transmitted pulse, echo strength, etc.

## Frequency

With the FMV-605, you have a choice of either 50kHz or 200kHz set. There are advantages and disadvantages to both frequencies and you should select the frequency best suited to your needs.

- High frequency is useful to detect species which do not have air bladders (e.g., sharks) or which are very small and do not readily reflect the echo.
- When the sea is rough, noise heavily covers the surface layer, and sounding is easily interrupted by aerated water which passes below the transducer. It should be noted that a high frequency is less influenced by rough sea when compared with a low frequency. However, in the application where observation of DSL (plankton layer) is first essential, use low frequency since such scattering objects are clearly plotted.
- To watch the seabed condition in the bottom trawling, a low frequency is preferable because the seabed is plotted thickly and changes of the width can be easily noticed. A wide seabed trace indicates a hard seabed and a narrow trace a soft seabed.
- Though a high frequency offers a sharp, clear-cut picture, its use should be limited to shallow water fishing because it is easily attenuated in the water.

## Detecting Area

The detecting area varies depending on the main beamwidth of the transducer, as shown below. Objects out of the main beam but close to the beam will be presented less densely, smaller in size, and at a lower intensity.

Generally, beamwidth depends on transmission frequency; a narrower beamwidth is usually obtained at the higher frequency. For example, the 200 KHz transducer has a "-3 dB" beamwidth of



approximately 10 degrees, whereas the 50 KHz transducer has a beamwidth of approximately 46 degrees.

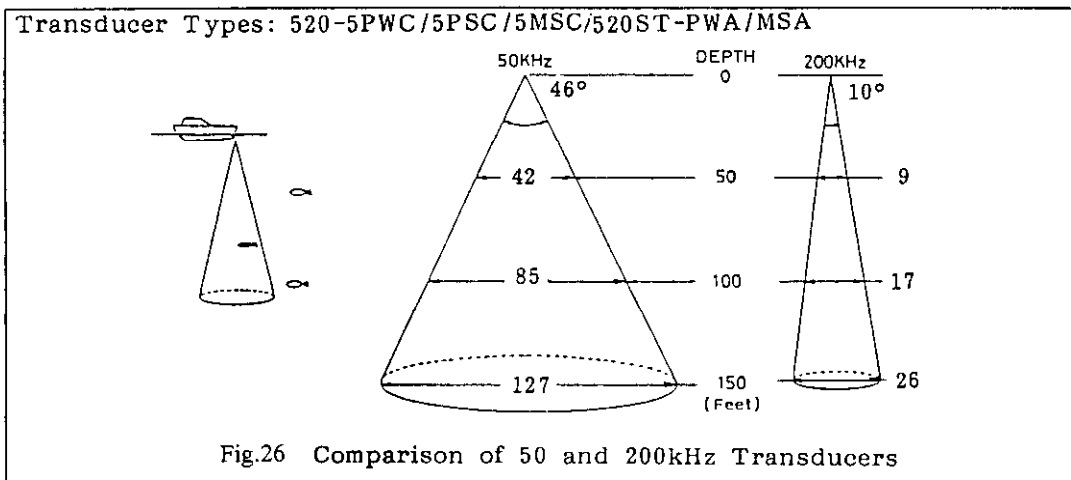

Because the beam width of the 200kHz transducer is narrow, the operator has the advantage of higher resolution. In addition, the effects of cruising noise and air bubbles are greatly reduced, since air bubbles resonate at a frequency between 15 and 100kHz. On the minus side, a narrow beamwidth transducer will display even the smoothest bottom contour in a sawtooth pattern if the boat is moving up and down due to pitching and rolling of the boat. This makes discrimination of fish down close to the bottom difficult.

Because of the limited coverage area, a narrow beamwidth tends to overlook catchable fish at the sides of the boat. (The maximum percent of depth covered on the bottom for the 200kHz transducer is 17% of the depth. For example, if the bottom depth is 300 feet, the diameter of the coverage circle on the bottom would be only 52 feet.)

## Zero Line

The zero line (sometimes referred to as the transmission line) represents the transducer's position, and moves off the screen when a deep phased range is used.

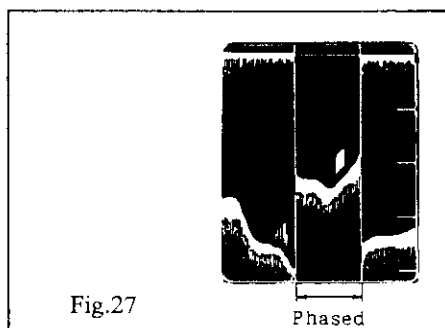

## Fish School Echoes

Fish school echoes will generally be plotted between the zero line and the bottom. Usually the fish school/fish echo is weaker than bottom echo because the reflection property are much smaller than compared to the bottom. The size of the fish school can be ascertained from the density of the display.

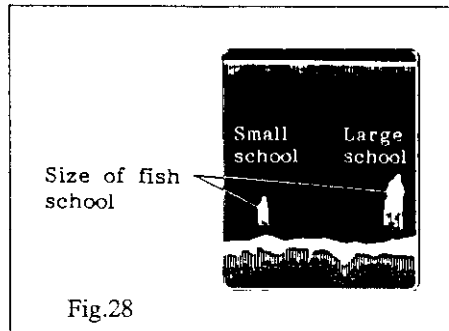

## Bottom Echo

Echoes from the bottom are normally the strongest and are displayed in the reddish brown color but the color and width will vary with bottom composition, water depth, frequency, sensitivity, etc.

In a comparatively shallow depth, a high gain setting and strong bottom echo will cause a second or sometimes a third or a fourth echo to be displayed at the same interval between them below the first echo trace. This is because the echo travels between the bottom and the surface twice or more in shallow depths.

The intensity of the bottom echo can be used to help determine the density of the bottom materials (soft or hard). The harder the bottom, the wider the trace. If the gain is set to show only a single bottom echo on mud, rocky bottom will show a second or third bottom return. The Basic Range chosen should be set to show the first and second bottom echoes when bottom hardness is being determined.

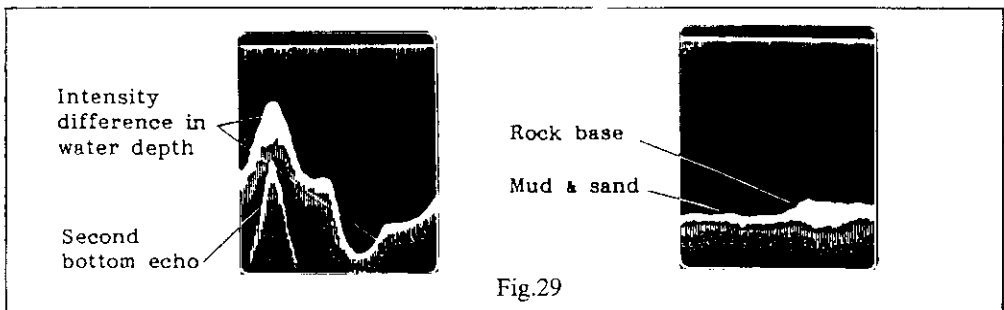

In a rough waters the bottom is recorded in a zig-zag pattern, similar to the teeth of a saw. This is caused by the heavy pitching and rolling of the boat, causing the sounding direction to fluctuate and the distance to the bottom to vary.

## Surface Noise/Aeration

When the waters are rough or the boat passes over a wake, surface noise may appear near the zero line. As surface turbulence is acoustically equivalent to running into a brick wall, the bottom echo will be displayed intermittently. Similar noise sometimes appears when a water temperature difference (thermocline) exists. Different species of fish tend to prefer different temperature zone, so thermocline information may be useful to help identify target fish. 200kHz tends to show shallow thermoclines better than 50kHz.

In rough waters the display is occasionally interrupted due to below-the-ship air bubbles obstructing the sound path. This also occurs when the boat makes a quick turn or reverses movement. Lowering the picture advance speed may reduce the interruption. However, reconsideration of the transducer installation may be necessary if the interruption occurs frequently.

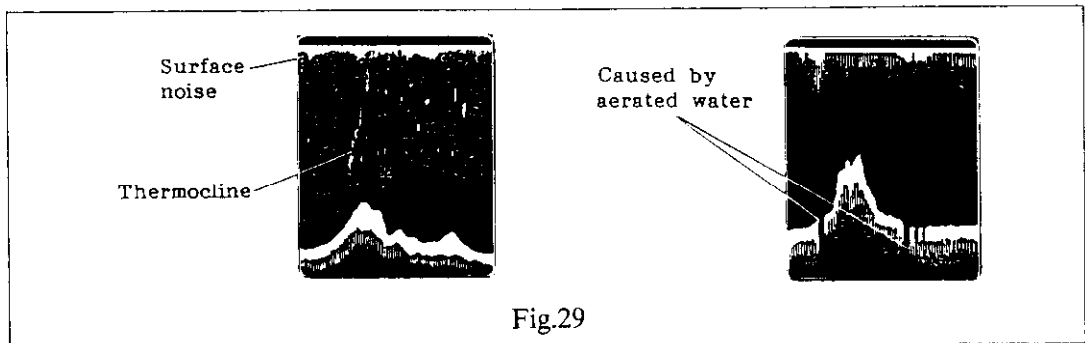

Fig.29

# 4. MAINTENANCE

## General

The equipment will maintain optimum performance for a long period . However, continued performance cannot be expected without periodic inspection and maintenance. Important pints to be checked from time to time are tabulated below.

Check Item	Action
Cable run	If cut, replace it
Power cable plug/transducer cable plug	If loosened, secure it firmly.
Display unit grounding	If corroded, clean it.
Ship's mains voltage	If out of ratings, correct problem.

## Fuse Replacement

To protect the equipment from serious damage, a fuse is provided on the power cable, as illustrated. The fuse protects against over-voltage/reverse polarity of the ship's mains or internal fault of the equipment. If the fuse has blown, first find the cause of the problem before replacing it with a new one. A fuse rated for more than 3A should not be used, since it may cause serious damage to the equipment.

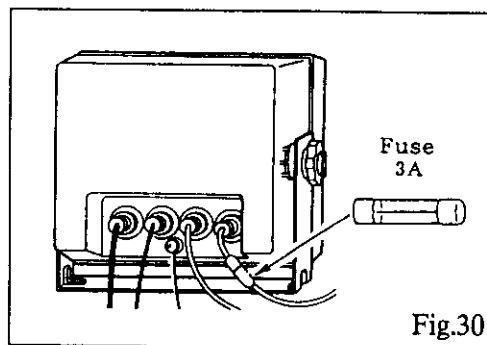

## Cleaning And Lubrication

Keep the equipment clean and dry at all times. Dust or Lose dirt should be wiped off with a soft, dry cloth. To remove heavy dirt, use mild detergent and water on a cotton tipped swab or soft cloth.

#### ■ CAUTION

*Never apply plastic solvent, such as thinner or acetone, for cleaning and lubrication . It may dissolve paint coating/markings on the front panel.*

## Maintenance Of The Transducer

Underwater growth on the transducer face will result in a gradual decrease in the sensitivity. Check the transducer face each time the boat is dry-docked. If any barnacles or seaweed growth is found, remove them very carefully with a piece of wood or sandpaper, taking care not to damage the transducer face.

# 5. TROUBLESHOOTING

If something appears wrong with your unit, check the equipment referring to the "Basic troubleshooting for user. In case the trouble isn't found after performing these checks, and the unit still appears faulty, call your electronics technician for service.

## Basic Troubleshooting

Note that the number listed on each possible cause corresponds to that of the illustration on the next page.

### Neither echo nor fixed range scale

- |                                      |   |
|--------------------------------------|---|
| * Is the battery dead? .....         | 1 |
| * Is the fuse blown? .....           | 2 |
| Supply voltage is normal?            |   |
| Corrosion on battery terminal? ..... | 1 |
| * Poor contact of power cable?.....  | 1 |

### No echo but fixed range scale shows

- |   |   |
|---|---|
| * Is the picture advance rate set to "0"? ..... | 3 |
| * Transducer plug is loose? .....               | 4 |

### Echo appears but no zero line

- |  |   |
|--|---|
| * Is the range shifting operative? ..... | 5 |
|--|---|

### Low sensitivity

- |   |   |
|---|---|
| * Is the gain setting too low? .....  | 6 |
| * Air bubbles or underwater growth (barnacle, seaweed, etc.) attached to the transducer face? ..... | 7 |
| * Highly sedimented water? .....  | 8 |
| * Soft bottom? .....  | 9 |

### No water depth readout

- |   |    |
|---|----|
| * Bottom echo is painted with BRIGHT intensity? ..... | 6  |
| * Bottom is displayed on the screen?.....             | 10 |

### Heavy noise or interference

- |   |    |
|---|----|
| * Is the transducer/cable located too near the engine? .....          | 11 |
| * Is the unit grounded? .....   | 12 |
| * Are other echosounders of the same frequency operating nearby?..... | 13 |

No or unrealistic speed/temperature indication

\* Sensor plug is loose?.....14

No or unrealistic ship's position indication

\* Plug for the position fixing equipment is loose?.....15

\* The position fixing equipment itself is operating normally?.....16

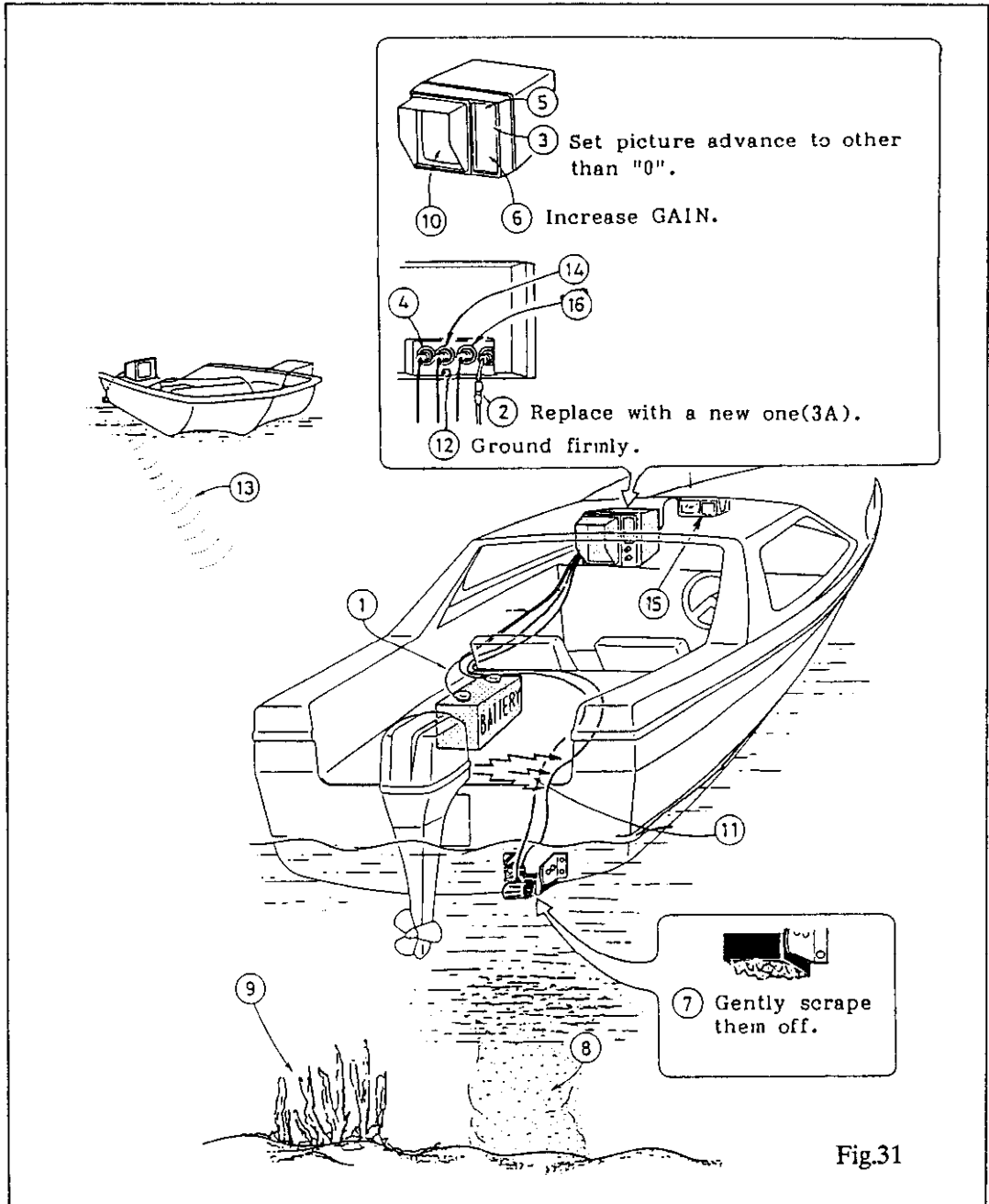

Fig.31

- ⑪ Try to mount a large electrolytic capacitor right at the output terminals of the alternator as close as possible. The capacitor must be rated for the nominal output voltage of the alternator, plus a 50% safety factor and capacity should be about 10,000 microfarads or so. The positive lead of the capacitor is connected to the output terminal of the alternator in parallel with the heavy lead going to the battery bank. The negative terminal of the capacitor should go to a mounting bolt used to secure the alternator to its mounting frame. Be careful to observe polarity of the capacitor. Reverse polarity will destroy the capacitor, and could damage the charging system as well.

Note that do not connect the capacitor to the field terminal of the alternator, as the risk destroying the alternator itself.

## Transducer Check

A simple and reliable check of the transducer is to temporarily substitute a new transducer instead of the existing one to the display unit. If the picture sensitivity is considerably improved through this change, the transducer is considered to be faulty. This method is especially useful for inside-hull or through-hull installation.

The following quick check also helps to judge the performance of the transducer to some extent.

Haul the transducer from the water and turn on the POWER. Put your ear near the transducer face and carefully listen to the transmission sound. If you can hear a clicking sound, the transducer is probably OK. Next, rub the transducer face with your hand and observe whether any noise appears on the screen. The appearance of noise indicates that the transducer is normal. In case of neither sound nor noise, the transducer is likely to be faulty.

## Speed/temperature Sensor Check

The idea of transducer check can apply to this case, too; temporarily substitute a new sensor instead of the existing one to the display unit. If the speed/temperature indications become normal through this exchange, the sensor is considered to be faulty.

Unless a new sensor is available, try the following checks.



First, unplug the sensor connector from the display rear panel. If the speed is indicated "00" and the temperature indicate "\*20" or around, the display unit will be all right.

Next, turn the water wheel with a finger. If the sensor is normal, the speed indication will be 2 to 3 knots when the wheel is turned at a normal speed and will be 7 to 8 knots when turned more quickly. As for the temperature, the reading should change when you touch the thermosensor as shown in Fig.32.

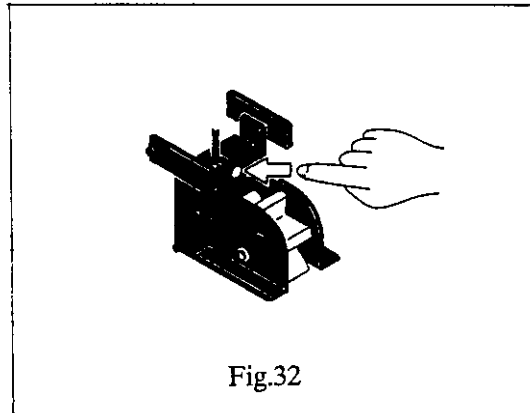

# 6. CHANGING INTERNAL SETTINGS

## Change Of Specifications

Jumper wires are provided on the MIN board to allow custom tailoring of the unit to specific uses, such as fishing method, fishing ground, etc. To change the settings;

- 1) Turn off the POWER.
- 2) Remove the cover.
- 3) Change the jumper wire with a soldering iron as shown below.

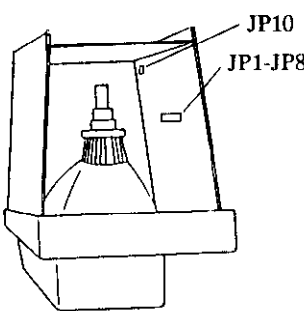

No.	Items	Setting					
		Short			Open		
1	Depth Unit	M	Short	FT	Open	FA	Short
2			Short		Short		Open
3	Temperature Unit	°C			°F		
4	Temperature Sensor (See note 1.)	SENS			NAV		
5	Frequency (See note 2.)	50kHz			200kHz		
6	Speed Unit	MPII	Short	KM	Short	KTS	Open
7			Short		Open		Short
8	Speed Sensor (See note 1.)	SENS			NAV		
10	Gain Preset (See note 3.)	Outside Hull XDCR			Inside Hull XDCR		

Fig.33

### ■ NOTE

- 1) SENS for speed/temperature sensor and NAV for navigation equipment.
- 2) To change frequency, modification of MIN board and replacement of the TX/RX board are also required.
- 3) Opening JP10 increases the receiver gain to offset signal attenuation through the hull.

# 7. INSTALLATION OF OPTIONAL DEVICES

## Transom Mount of Transducer

### Introduction

This type of mounting is very commonly employed, usually on relatively small I/O or outboard boats. Do not attempt this mounting on an inboard boat due to turbulence created by the propeller ahead of the transducer.

### Procedure

1. Attach the transducer to the bracket as shown in Fig.34.
2. To determine a suitable transducer mounting location, run the boat at several speed ranges and observe the water flow at the rear and near the transom. Suitable location is at least 50 cm (18") away from the engine and where the water flow is smooth.
3. On a relatively flat hull, the transducer is mounted flush with the hull-bottom, and there are two choices of installation as shown in Fig.34. Note that the direction of the transducer and its fixing holes on the brackets are different for each method. Although there is less influence from air bubbles with method (2), you must be careful not to damage the transducer when the boat is hauled out of the water/put on a trailer. On a deep "V" hull, the transducer is mounted in the same manner as method (2) for the Hat hull. It should be mounted as near as the bottom edge of the transom, and the transducer face must be paralleled with the seabed, not with the hull bottom.
4. Mark the screw locations by holding the transducer in position on the transom.
5. Drill four pilot holes.
6. Mount the transducer and secure it with four self-tapping screws. A small amount of sealing compound under the head of each screw will preserve the watertight integrity of the transom.
7. Adjust the transducer position so that the transducer faces right the seabed.
8. If necessary, to improve water flow and minimize air bubbles staying on the transducer face, incline the transducer about 5 degrees at the rear. This may require a certain amount of experimentation for line-tuning at high cruising speeds.
9. Fill the gap between the wedge front of the transducer and transom with epoxy material to eliminate any air spaces.

When the transducer with speed/temperature sensor (molded in one unit: 520ST-PWA) is installed, follow the installation method (2) on the next page.

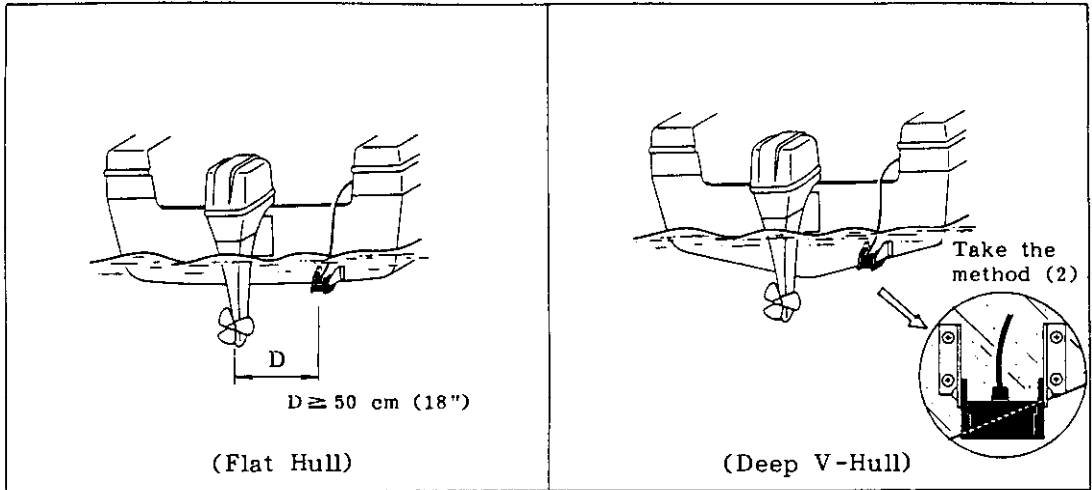

**METHOD (1) ... flush with hull**

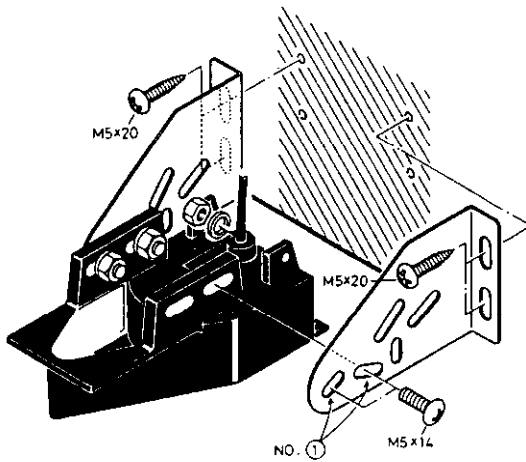

Cover the gap between transducer and hull board with tape. Fill in with epoxy materials and wait until dry. When dry, remove tape.

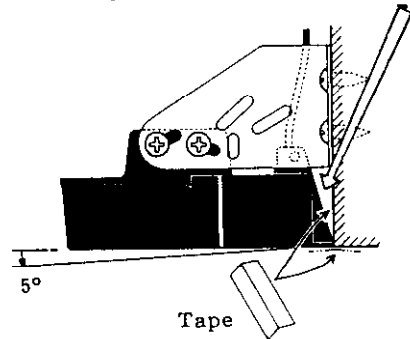

**METHOD (2) ... projected from hull**

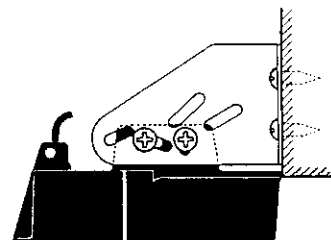
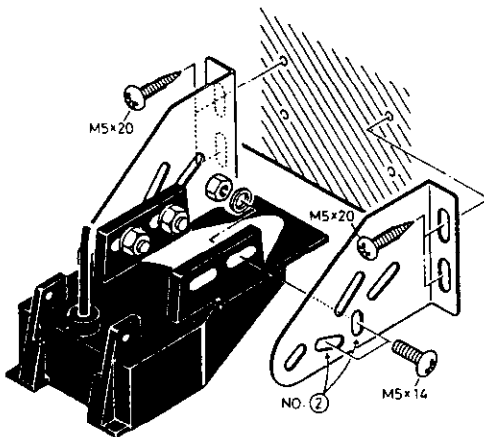
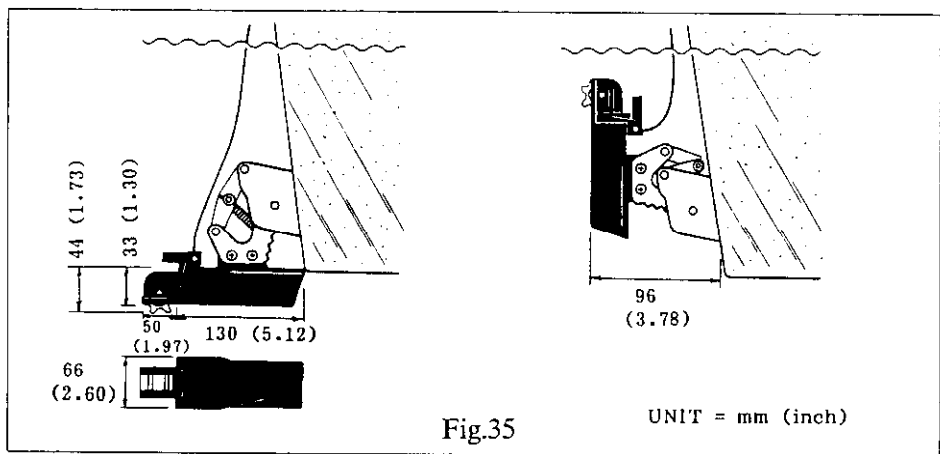

**Fig.34 Installation**

## Mounting Transom Type Transducer using Kick-up Bracket (0P02-29)

When the transducer is mounted extruded from the hull bottom as shown in Fig.34 (page 45), it is subject to damage or loss due to floating objects, such as a log.

To minimize such an accident it is recommended to install the transducer, using the optional Kick-up Bracket as shown below. When an impact by the floating object or extraordinary water pressure is added, the transducer will be kicked up and damage or loss will be avoided. It is also a good idea to flip the transducer up when the boat hauled out of water and put on a trailer.



## Mounting Transom Type Sensor (ST-01PTB)

- 1) When the transom type transducer (520-5PWC) is mounted extruded from the hull bottom as shown in Fig.34 (page 45) or is mounted with the kick-up bracket, the sensor can be directly attached to it as shown below using any installation material.

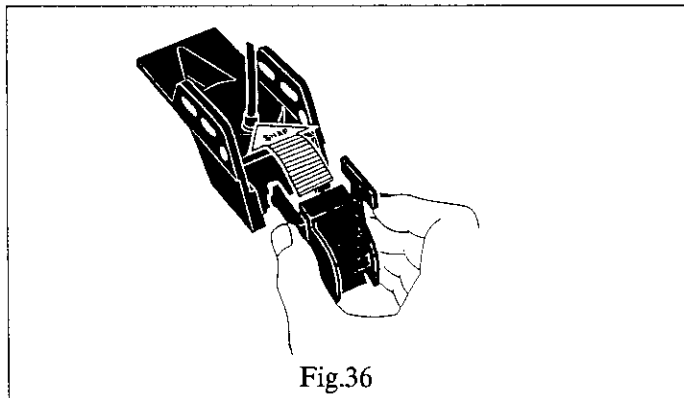

- 2) When the transom type transducer (520-5PWC) is mounted flush with the hull bottom as shown in Fig.34 (page 45), the sensor can not be attached to the transducer because it is mounted with the sensor snapping side directed to the transom. In such a case, the sensor must be installed separately, using the optional sensor Bracket (0P02-30). See below figure.

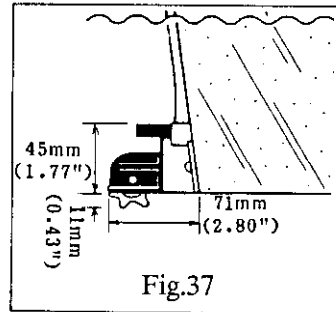

## Mounting Temperature Sensor

### Transom Type (T-02MTB)

#### Mounting Location and Method

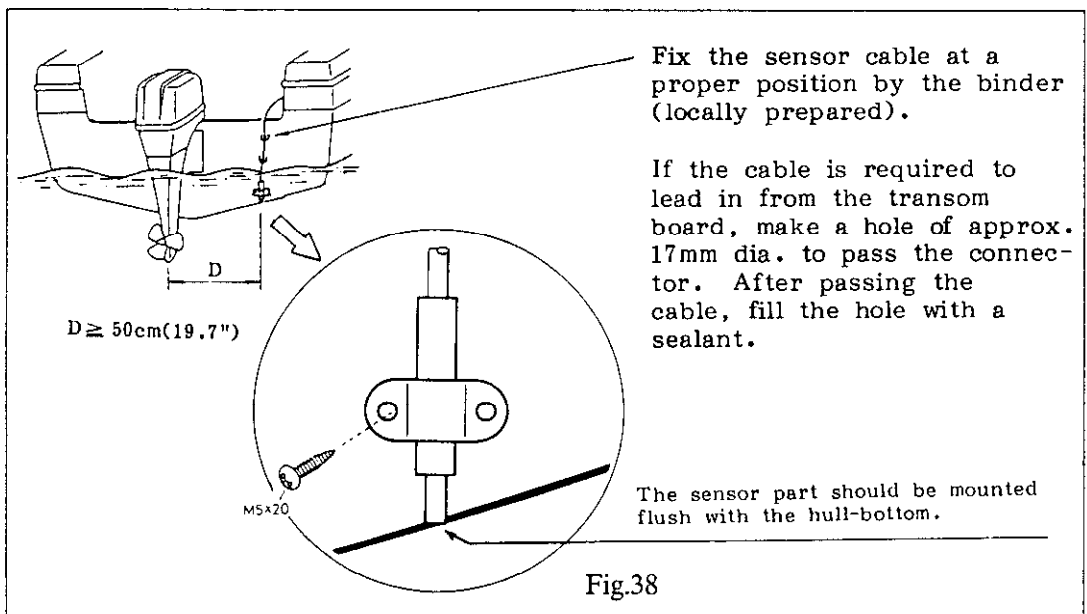

### Thru-hull Type (T-02MSB, T-03MSB)

#### Mounting Location

- Select a mid-boat, flat position. The sensor does not have to be installed perfectly perpendicular. The sensor must not be damaged in dry-docking operation.

- Select a place apart from the equipment generating heat.
- select a place in forward direction viewing from the drain hole for cooling water.
- Select a place free from vibration.

## Mounting Procedure

T-02MSB		T-03MSB	
1)	Dry-dock the boat.	1)	Dry-dock the boat.
2)	Make a hole of approx. 21mm (0.8") dia. on the hull bottom	2)	Make a hole of approx. 25mm (1") dia. on the hull bottom.
3)	Run the sensor cable through the hole.	3)	Apply high-grade sealant to the holder guide flange and pass the holder guide through the hole.

21mm(0.8")

Rubber Packing  
Washer  
Lock Nut

Apply sealant.

Fig.39

Sensor Holder

Lock Nut

Washer  
Rubber Packing

ϕ25mm

Apply sealant.

Holder Guide

Fig.40

4)	Pass the cable through the rubber packing, the washer and the lock nut as shown above.	4)	Fix the holder guide to the hull bottom using the rubber packing, the washer and the lock nut. do not tighten the nut excessively. (600kg-cm max.)
5)	Apply high grade sealant to the sensor flange as shown above.	5)	Insert the sensor holder to the holder guide and tighten by the nut.
6)	Fix the sensor by turning the lock nut. Do not tighten the nut excessively. (600kg-cm max.)	6)	After the launching, check for water leakage around the sensor.
7)	After the launching, check for water leakage around the sensor.	<p><b>Note:</b></p> <p>1) For the boat of more than 25mm hull plate, this sensor is impossible to install.</p> <p>2) When the sensor seems to be deteriorated, the check, cleaning or replacement can be carried out without dry-docking.</p>	

## Mounting Display Unit using Optional Flush Mount Kit

Many owners will undoubtedly use the FMV-605 on small boats, many with center consoles and wish to mount flush with console panels. It is recommended that the optional flush mount kit OP02-60 be used for this purpose.

The mounting by using the flush mount kit is accomplished as follows.

1. Peel off paper from the liners and attach them to the inner surface of side plates of the flush mount chassis.
2. Fix the plastic edging on the back edge of the flush mount chassis.

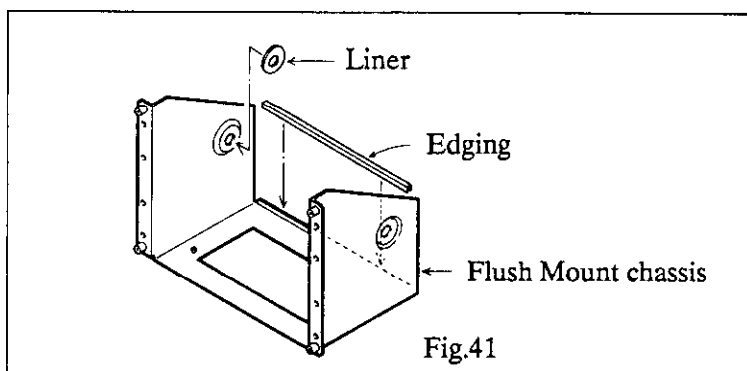



3. Prepare a 219mm by 180mm (8.62" by 7.08") cutout on the console panel and drill eight 6mm (0.24") diameter holes for fixing bolts. When tapping screws are used instead of bolts, drill pilot holes for the tapping screws.

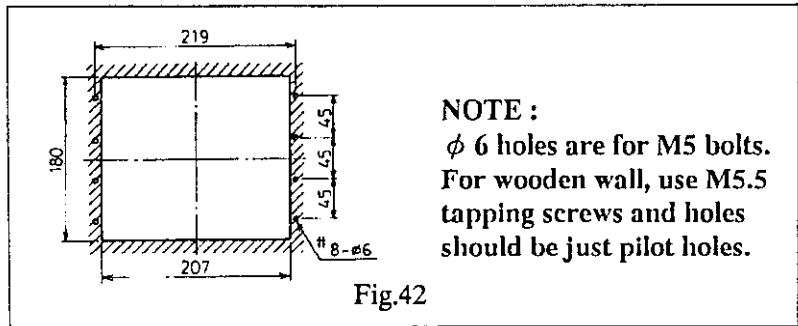

4. Fix the display unit on the flush mount chassis and install them on the console panel.
5. Attach the flush mount plate to the flush mount chassis.

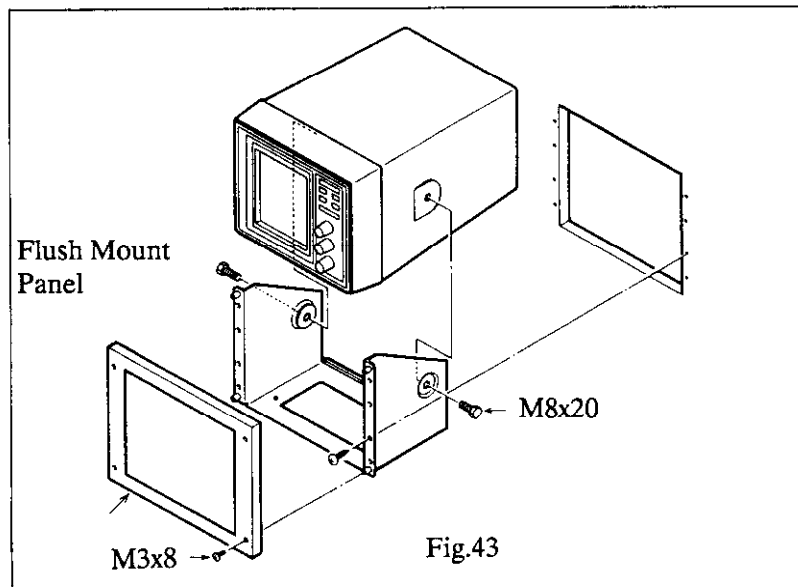

■ **NOTE**

*Align display unit panel to the alignment boss on the flush mount chassis before fixing with bolts.*

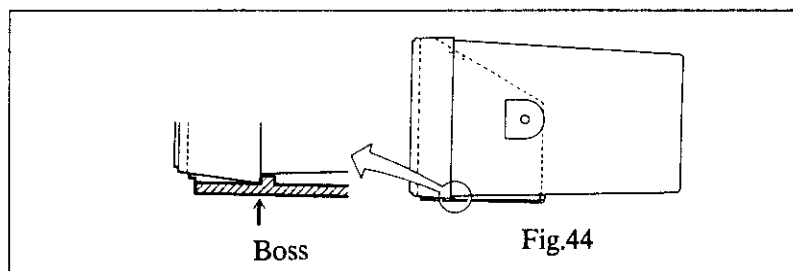

## Attaching Magnifying Lens to Viewing Hood

The optional magnifying lens expands the picture to xx" size. To attach it to the viewing hood follow the procedure below.

1. Peel off the factory-attached sticker from the top of the hood.
2. Fix the caution level to underside of the hood.
3. Set the legs of the lens in holes of the viewing hood.

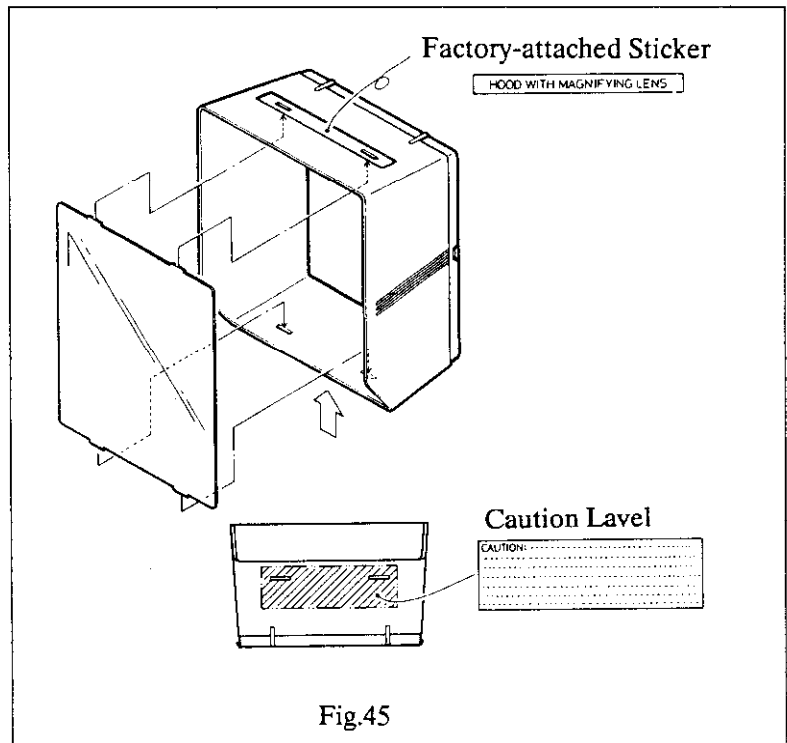

MODEL	FMV 605	
UNIT	DISPLAY UNIT	PAGE
REF. DWG.	C2336-K01-A	BLOCK NO. 1

## ELECTRICAL PARTS LIST

電気部品表

1991- 7

SYMBOL	T Y P E	SPECIFICATIONS	CODE NO.	REMARKS
記 号	型 名	規 格	コード番号	備 考
PRINTED CIRCUIT BOARD		プリント基板		
22P-0036B/0037	PNL	FMV-605	001-378-170	
22P-0039	CRT	FMV605/FCV665	001-378-270	
22P-0056	24V PWR	FMV605/FCV665	001-378-280	
22P-0029/50KC	TX	FMV605/FCV605	001-378-360	
22P-0029/200KC	TX	FMV605/FCV665	001-378-370	
22P-0035	MIN	FMV-605	001-378-400	
22P-0056	24V PWR	FCV-665/FMV-605	001-379-320	
22P-0041B	CON		001-379-420	

- END -

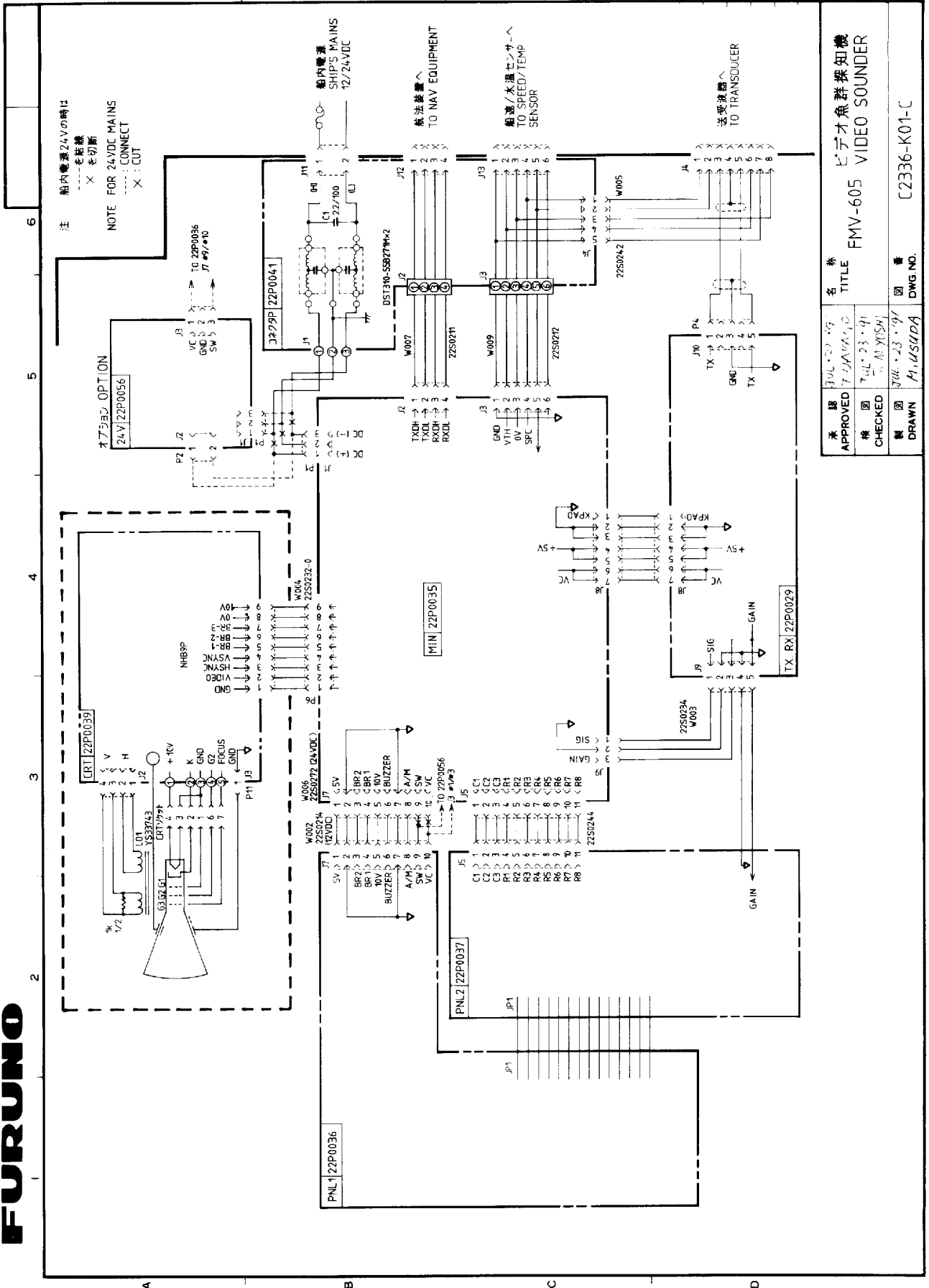

注 船内電源24Vの時  
 --- 名義線  
 X 名切筋

NOTE FOR 24VDC MAINS  
 --- : CONNECT  
 X : CUT

承認 APPROVED	訂正 REVISED	名称 TITLE
検閲 CHECKED	検閲 CHECKED	FMV-605 VIDEO SOUNDER
製図 DRAWN	製図 DRAWN	富士電機株式会社 FUJITSU ELECTRIC CO., LTD.
		図番 DWG. NO.
		C2336-K01-C

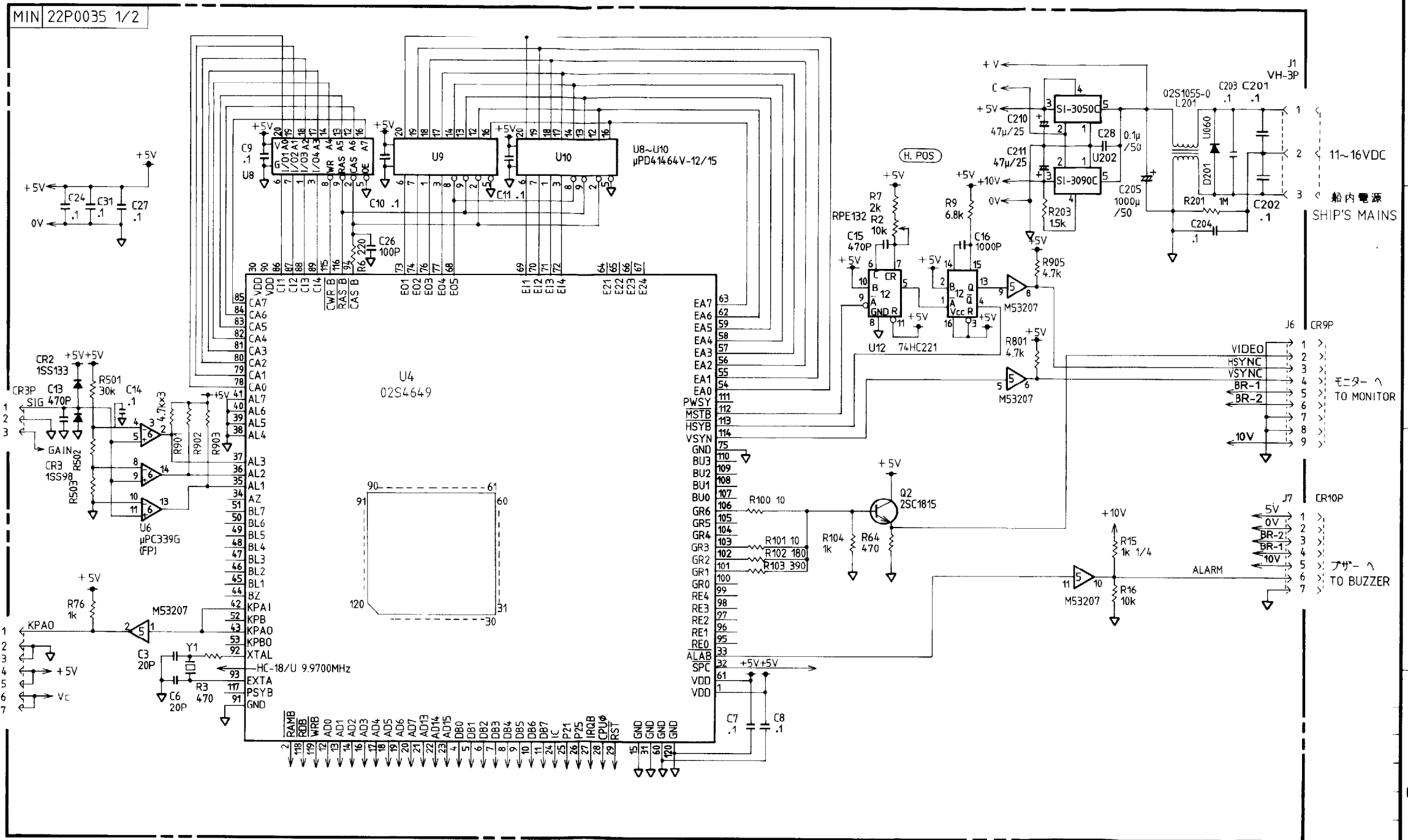

承認 APPROVED	SEP. 20. '91 T. TAKANO	名称 TITLE	22P0035 MIN基板 (1/2)
検図 CHECKED	SEP. 20. '91 T. MIYASHI		
製図 DRAWN	SEP. 20. '91 M. USUDA	図番 DWG. NO.	C2336-K04-C

FILE-605

MIN 22P0035 2/2

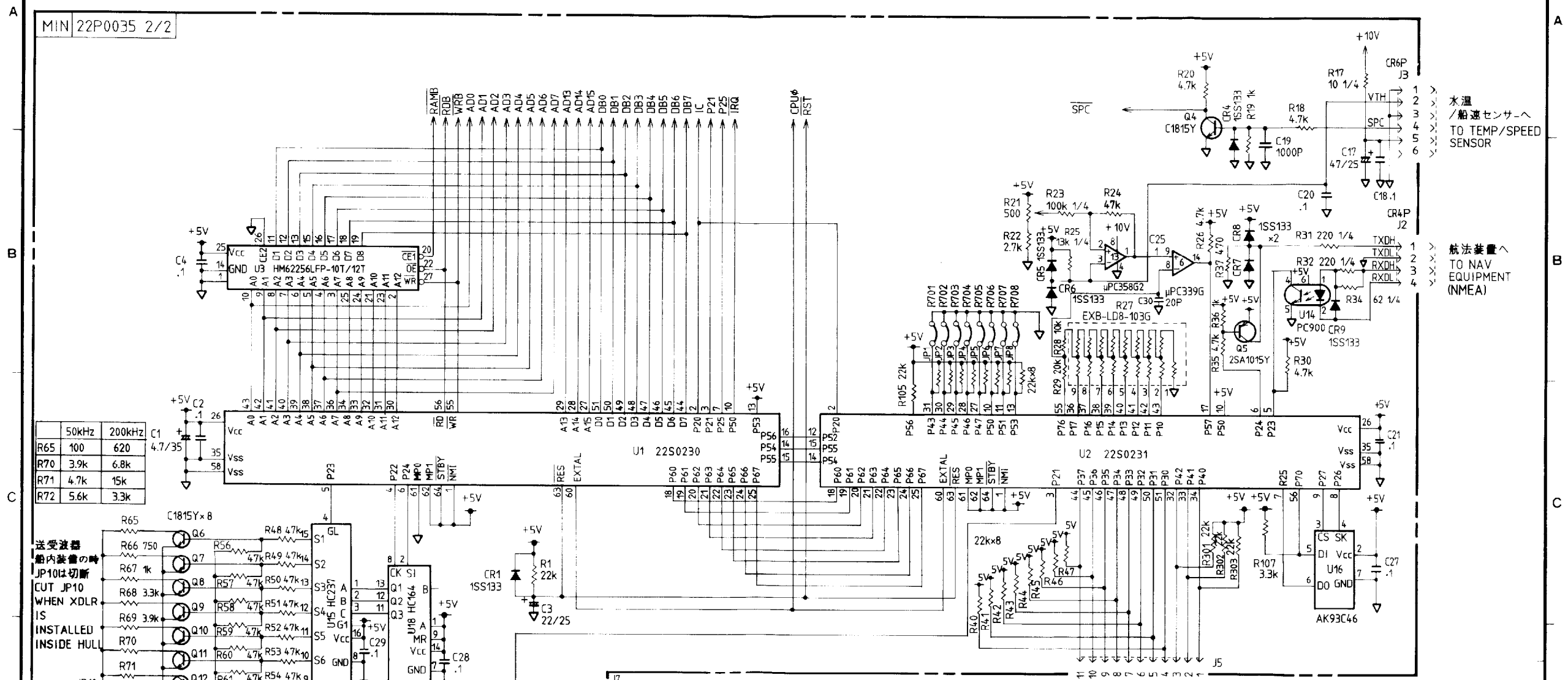

	50kHz	200kHz
R65	100	620
R70	3.9k	6.8k
R71	4.7k	15k
R72	5.6k	3.3k

送受波器  
船内装置の時  
JP10は切断  
CUT JP10  
WHEN XDLR  
IS  
INSTALLED  
INSIDE HULL

水温  
/ 船速センサーへ  
TO TEMP/SPEED  
SENSOR

航法装置へ  
TO NAV  
EQUIPMENT  
(NMEA)

	JP1	JP2	JP6	JP7
M	SHORT	SHORT	MPH	SHORT
FT	OPEN	SHORT	KTS	OPEN
FA	SHORT	OPEN	KM	SHORT
			OPEN	OPEN

	JP3
°C	SHORT
°F	OPEN

TEMP	JP4
IN	SHORT
OUT	OPEN

SPEED	JP8
IN	SHORT
OUT	OPEN

P.GAIN	JP10
NORM	SHORT
UP	OPEN

承認	SEP. 20. '91	名称	
APPROVED	T. KAWA	TITLE	22P0035 MIN基板 (2/2)
検	SEP. 20. '91		
CHECKED	T. MIYASHI		
製	SEP. 20. '91	図番	C2336-K05-C
DRAWN	M. USUDA	DWG. NO.	

FMV-A05

50kHz	200kHz
*1 10k	1.2k
*2 680P	1000P
*3 0.01μ	1000P
*4 3300P	1000P
*5 1800P	4.70P
*6 0.01μ	2200P
*7 0.01μ	0.250827 0.250828
*8 0.250828	0.250831
*9 0.250830	0.250831
*10 0.250829	0.250830

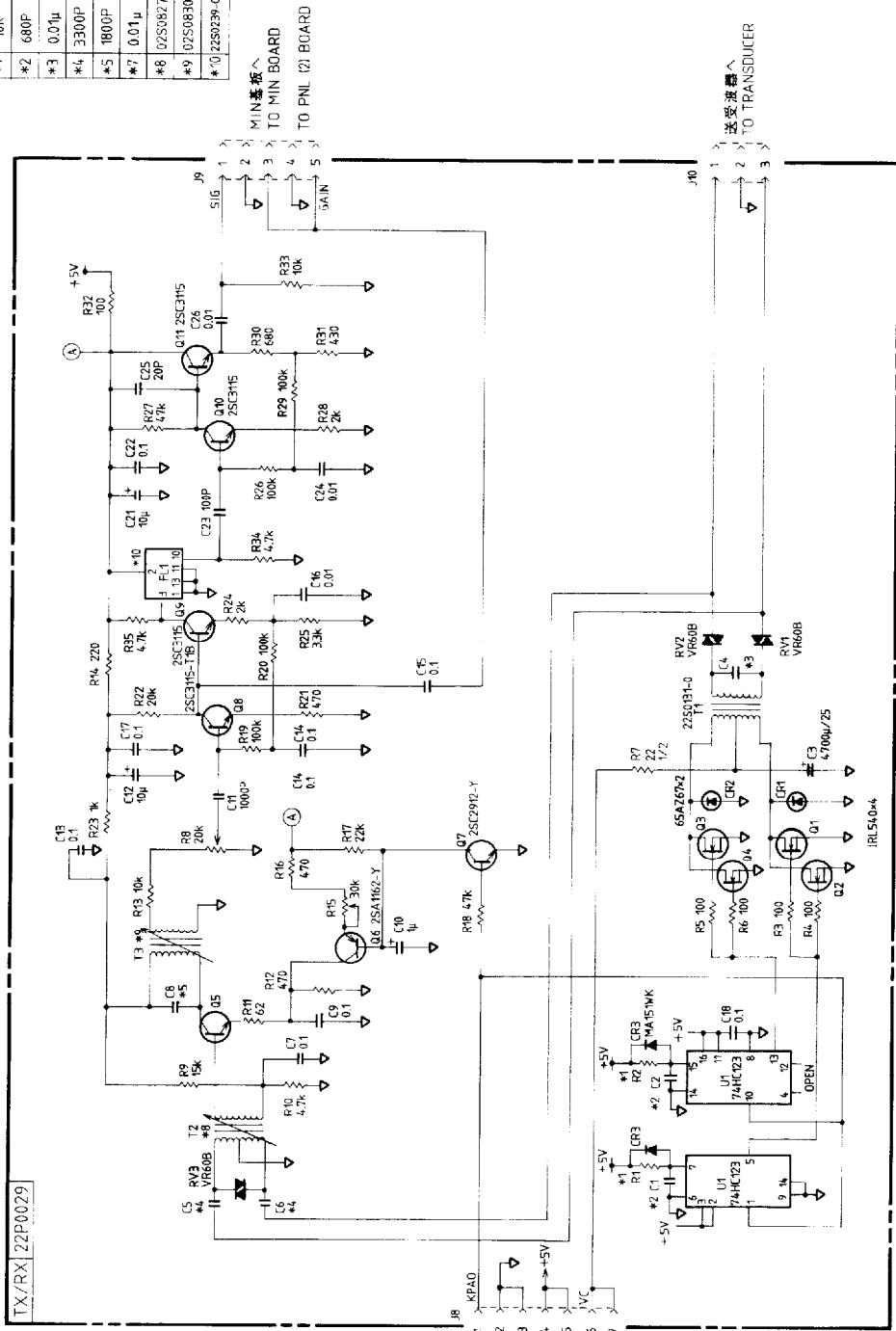

承認	名 称	22P0029
APPROVED	TITLE	TX/RX基板
検 査		TX/RX BOARD
CHECKED		
製 図	図 番	C2335-K02-C
DRAWN	DWG. NO.	

REV. 065

A

B

C

D

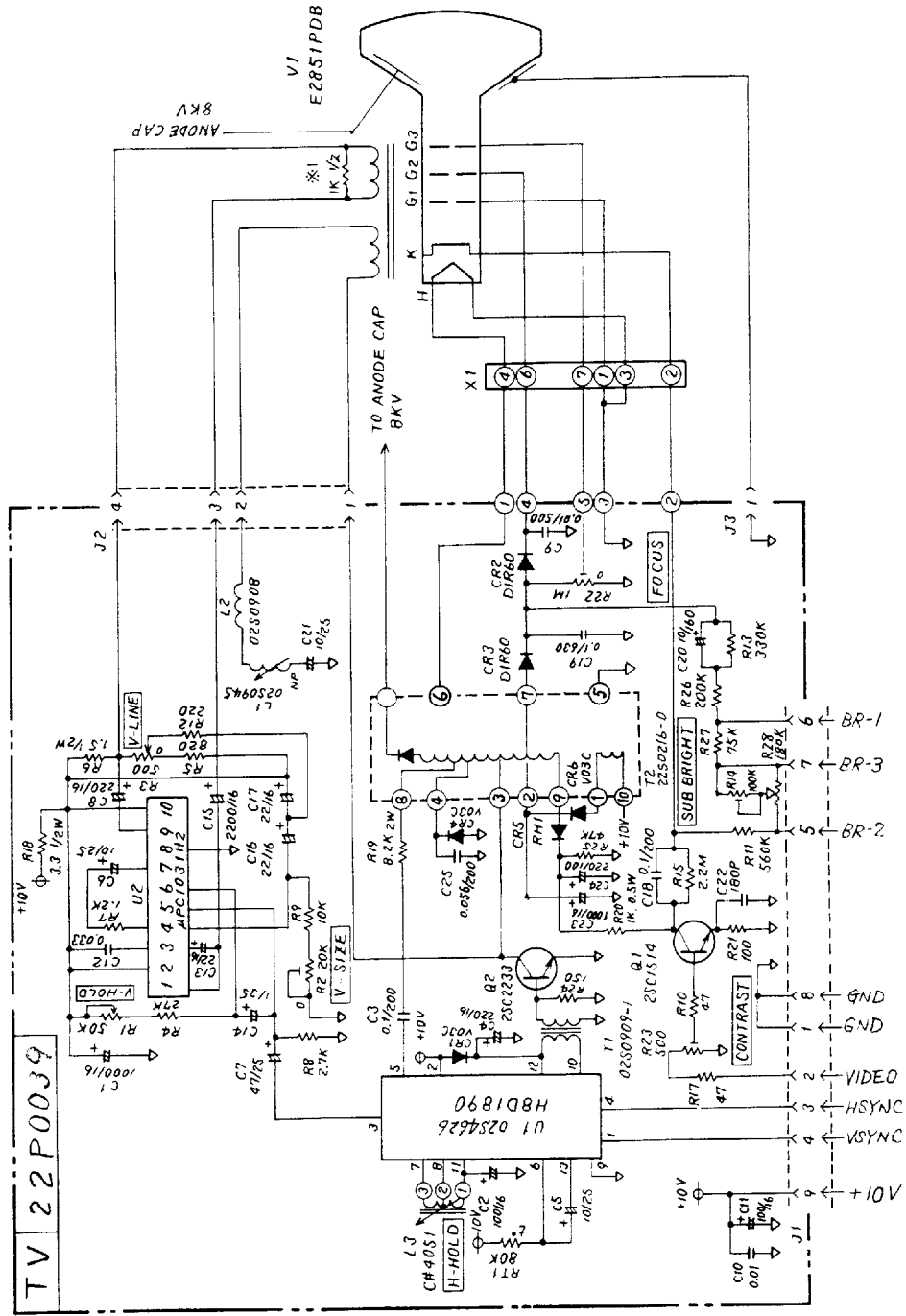

TV 22P0039

FMV-B15

品番 ITEM	品名 NAME	材質 MATERIAL	数量 Q'TY	圖番 DWG. NO.	摘要 REMARKS
------------	------------	----------------	------------	----------------	---------------

承認 APPROVED	△ 8. 8. 81 T. L. A. O. O.	三角法 THIRD ANGLE PROJECTION	名稱 TITLE	モニタ一回路 MONITOR DISPLAY	
檢圖 CHECKED	AUG. 8. 81 M. U. S. H. I.	尺度 SCALE			
製圖 DRAWN	AUG. 8. 81 M. U. S. H. I.	重量 WEIGHT	kg	圖番 DWG. NO.	C 2 3 3 6 - K 0 3 - B



A

B

C

D

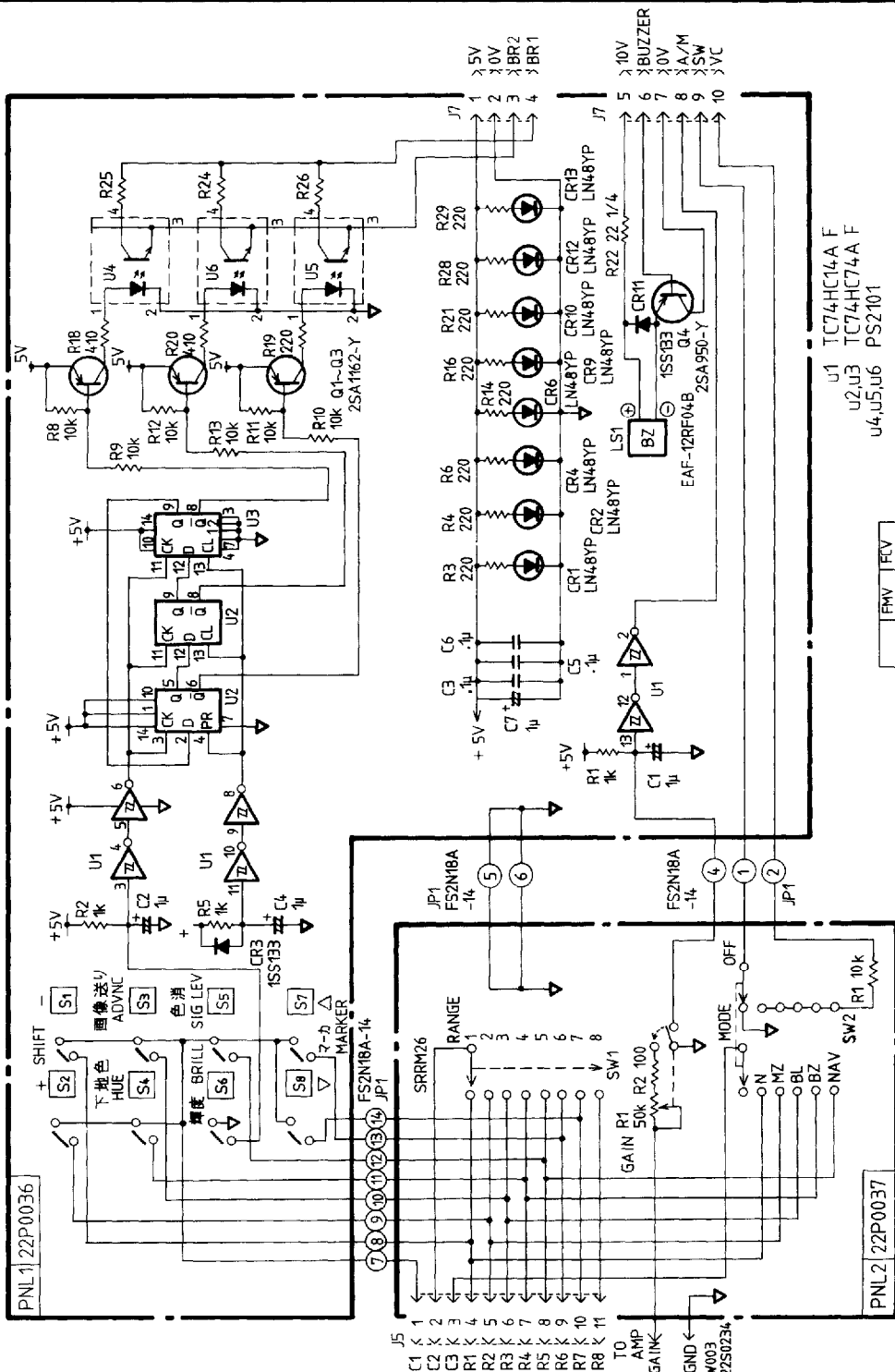

FLV	-665
FMV	-605
R25	10 10
R24	47k 50
R26	390k 620

- U1 TC74HC14A F
- U2,U3 TC74HC74A F
- U4,U5,U6 PS2101

注) 特配なき抵抗はERD16TJ型とする。  
NOTE ALL RESISTORS ARE OF ERD16TJ TYPE UNLESS OTHERWISE NOTED.

承認 APPROVED	品番 ITEM	品名 NAME	材質 MATERIAL	数量 Q'TY	図番 DWG.NO.	摘要 REMARKS
承認 APPROVED	JUL 23 2001	三角法 THIRD ANGLE PROJECTION	名称 TITLE			
検 CHECKED	JUL 23 2001	尺 SCALE	22P0036/22P0037			PNL1/PNL2 基板 PNL1/PNL2 BOARD
製 DRAWN	M. USUDA	重 WEIGHT	kg	図 DWG. NO.		C2335-K04-C

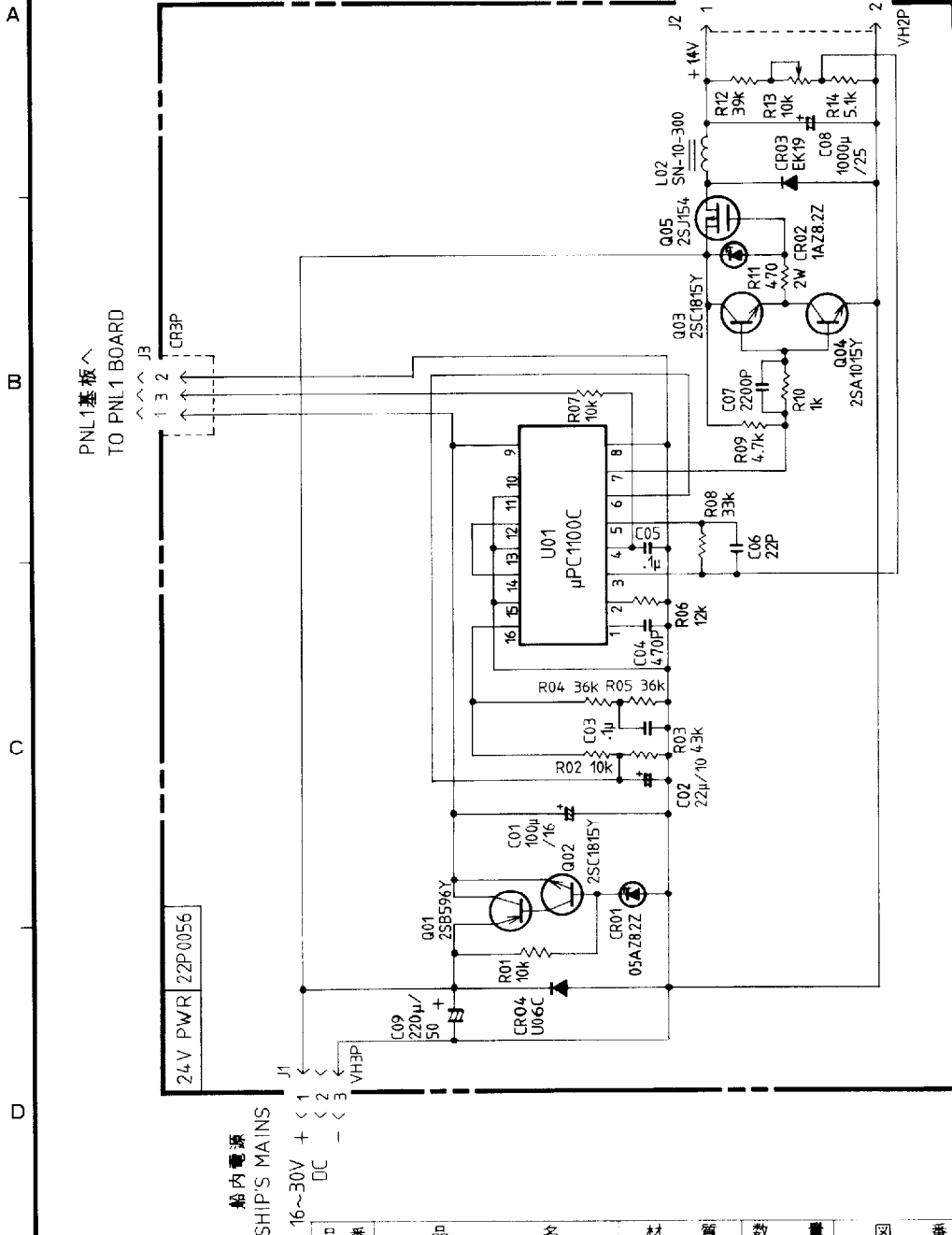

承認 APPROVED	品番 ITEM	品名 NAME	材質 MATERIAL	數量 Q'TY	圖番 DWG.NO.	摘要 REMARKS
承認	22P0056	三角法 THIRD ANGLE PROJECTION				名稱 TITLE 24V PWR基板 22P0056 24V PWR BOARD
檢閱 CHECKED		尺碼 SCALE				
製圖 DRAWN		重量 WEIGHT	kg		圖番 DWG.NO.	C2335-K03-C

## Free Manuals Download Website

<http://myh66.com>

<http://usermanuals.us>

<http://www.somanuals.com>

<http://www.4manuals.cc>

<http://www.manual-lib.com>

<http://www.404manual.com>

<http://www.luxmanual.com>

<http://aubethermostatmanual.com>

Golf course search by state

<http://golfingnear.com>

Email search by domain

<http://emailbydomain.com>

Auto manuals search

<http://auto.somanuals.com>

TV manuals search

<http://tv.somanuals.com>