

No. : OM-E2317-0B

FURUNO

OPERATOR'S MANUAL

COLOR VIDEO SOUNDER

MODEL FCV-522

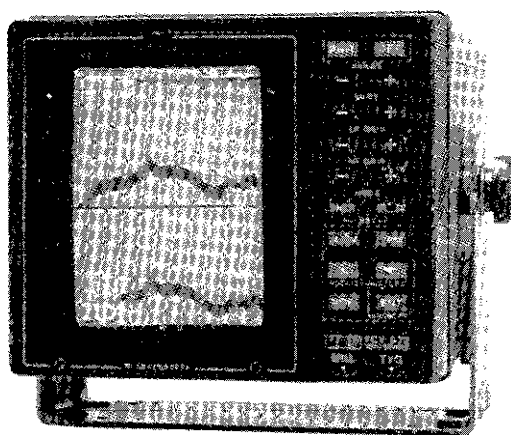

FURUNO ELECTRIC CO., LTD.
NISHINOMIYA, JAPAN

9003100K0 (8907, tami)
PRINTED IN JAPAN

WARNING AGAINST HIGH TENSION

The operation of this equipment involves the use of high voltage, which endangers human life. Although the design of the equipment has been made in due consideration of measures to insure the operator's safety, adequate precaution must be exercised when reaching inside the equipment for the purpose of maintenance and service. Do not change a component or inspect the equipment with the voltage applied. A residual charge may exist in some capacitors with the equipment turned off. Always short all supply lines to the chassis with an insulated screwdriver or a similar tool prior to touching the circuit.

FIRST AID IN CASE OF ELECTRIC SHOCK

When a victim struck by electricity is found, first switch off the equipment via the main switch on the equipment or the ship's distribution board. If this is not possible, protect yourself with dry insulating material (a wooden plate or rod, cloth, your belt, etc.) and pull the victim clear of electricity. If the victim is not breathing himself, apply artificial respiration according to the "Method of Artificial Respiration." Do not give up halfway. Perseverance and continual efforts are important in artificial respiration.

METHOD OF ARTIFICIAL RESPIRATION

Lay the victim on his back. Position yourself beside the victim's head and pinch his nose by your thumb and forefinger to prevent air leakage. Insert the thumb of your other hand between the victim's teeth and lift his chin up. Then, place the arm (the one closing the victim's nose) on the victim's forehead and press the head down so that the victim's head is given a maximum backward tilt with the chin prominent and the neck bent back. Seal the victim's mouth with your mouth and blow therein about half of the deeply inhaled air every time. After exhaling, turn your head to watch for a chest contraction, whilst inhaling deeply in readiness for the next blowing. Repeat the movements faster for the first 1 to 2 minutes and 12 times per minute thereafter.

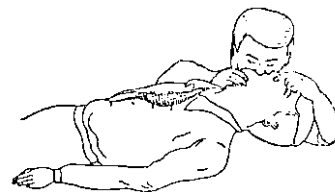
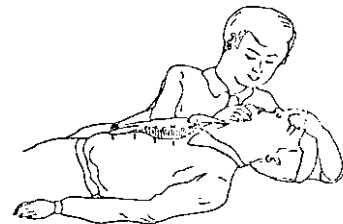

A WORD TO FURUNO FCV-522 OWNERS:

Congratulations on your choice of the FURUNO FCV-522 Color Video Sounder! We are confident that you will enjoy many years of operation with this fine piece of equipment.

For over 40 years Furuno Electric Company has enjoyed an enviable reputation for quality and reliability throughout the world. This dedication to excellence is furthered by our extensive global network of agents and dealers.

The FCV-522 Color Video Sounder is just one of the many Furuno developments in the field of echosounding. The compact, lightweight but rugged unit is easy to install and operate and is suitable for both fresh and salt water applications.

This unit is designed and constructed to give the user many years of trouble-free operation. However, to obtain optimum performance from this unit, you should carefully read and follow the recommended procedures for installation, operation and maintenance. No machine can perform to the utmost of its ability unless it is installed and maintained properly.

We would appreciate feedback from you, the end-user, about whether we are achieving our purposes.

Thank you for considering and purchasing Furuno equipment.

C O N T E N T S

A WORD TO FURUNO FCV-522 OWNERS	1
FEATURES	1
PICTURE MODE	2
KEYS AND CONTROLS	3
BEFORE BEGINING OPERATION	4
FIRST POWER APPLICATION	4
SUCCEEDING POWER APPLICATION	4
POWER OFF	4
DIP SWITCH SETTINGS	4
BASIC OPERATION	5 to 10
POWER ON/OFF	5
BRILLIANCE CONTROL	5
PRESENTATION MODE SELECTION	5
NORMAL PICTURE RANGE SELECTION	7
GAIN CONTROL	8
ADJUSTING TVG (Time Varied Gain)	8
ALARM (Fish Alarm, Bottom Alarm, Water Temperature Alarm)	9
TARGET DEPTH MEASUREMENT BY VRM (Variable Range Marker)	10
PICTURE STORE/RECALL	10
INDICATORS	11 to 13
ES PICTURE	11
GR PICTURE	12
NAV DISPLAY	13
ADVANCED OPERATION	14 to 18
FACTORY SETTINGS	14
GENERAL MENU SETTING PROCEDURE	14
PICTURE ADVANCE SPEED	14
GR PLOTTING SPEED	15
NOISE LIMITER	15
SHIFT MODE	15
THRESHOLD (SIGNAL LEVEL)	16
COLOR SELECTION FOR DAY AND NIGHTTIME OPERATION	16
DATA DISPLAY	16
SCALE DISPLAY	16
BOTTOM ALARM AND FISH ALARM ON/OFF	17
ALARM ZONE	17

WATER TEMPERATURE ALARM	17
WATER TEMPERATURE CALIBRATION	18
SHIP'S SPEED CALIBRATION	18
INTERPRETING THE DISPLAY	19 to 23
COLOR BAR	19
ZERO LINE	19
SEABED	20
BOTTOM PROFILE	20
BOTTOM NATURE	20
FISH SCHOOLS	21
FISH QUANTITY	21
BOTTOM FISH	21
PLANKTON/CURRENT RIP	22
SURFACE NOISE	22
AERATION	22
ZIG-ZAG BOTTOM	23
FALSE IMAGE	23
INTERFERENCE	23
IF SOMETHING SHOULD GO WRONG WITH YOU UNIT	24 to 27
OPERATION CHECK	24
Nothing Appears	24
No Echo Presentation, But Scale Shows	24
No Zero Line	24
Low Sensitivity	24
Multiple Seabed Traces	25
Zigzagged Seabed Trace/Occasional Loss of Echo Plotting	25
No Water Depth Readout/Bottom-lock Inoperative	25
Automatic Bottom Tracking Inoperative	25
Picture Distorted	26
Different Color Picture or Marker	26
Color Impurity in a Particular Area	26
Occasional Disturbance and Random Noise	26
Heavy Noise and Interference	26
SYSTEM DIAGNOSIS	27
INSTALLATION	28 to 35
DISPLAY UNIT	28
TRANSDUCER	30
TRANSOM MOUNT	31

FEATURES

INSIDE-HULL MOUNT	33
Through-Hull Mount	34
Transducer Preparation and Painting	35
FCV-522 CABLING DIAGRAM	36
HOW TO CHANGE INTERNAL SETTINGS	37
SPECIFICATIONS OF FCV-522 SOUNDER	38 to 42
SCHEATIC DIAGRAM	S-1 to S-6
APPENDIX	AP-1 to AP-5
INSTALLATION OF OPTIONAL DEVICES	AP-1
Mounting Transom Type Transducer using Kick-up	
Bracket (OP02-29)	AP-1
Mounting Transom Type Sensor	AP-1
Hooking up Ship's Position Data from Position	
Fixing Equipment	AP-2
Mounting Temperature Sensor	AP-4

The Furuno FCV-522 dual-frequency color video sounder provides a large variety of functions, by means of a state of the art computer technology, all contained in a splash-proof rugged aluminum case that is compact to fit almost any size boat.

- 1) Four modes of pictures(echo sounder, zoom picture, water temperature graph* and navigational data display*), which are concurrently plotted and selectively projected onto the screen.
- 2) 8-color presentation (including background) shows the variations in echo intensity, on an 8" diagonal CRT. Detailed information on fish density and the nature of the bottom are obtainable. For daytime operation, a 6-color presentation mode is available.
- 3) Eight basic ranges, from 0-5m to 0-300m. Unit of measurement may be changed from meters to fathoms, feet or passi/braza.
- 4) Range shifting allows the start of basic range to be set from zero to a maximum of 300 meters, and automatic bottom tracking mode permits unattended range phasing operation.
- 5) Variable range marker measures exact target depth and also sets the range to be zoomed for detailed observation.
- 6) Either a bottom alarm or a fish alarm may be activated. The operator is alerted when bottom echoes or fish echoes between the transducer and the bottom enter into the operator preset alarm zone. Also a water temperature alarm* is available to locate fish habitats.
- 7) Picture record/recall function permits later reference.
- 8) Digital display of ship's position*, own ship's speed*, water temperature* and alarm zone settings in addition to water depth ensures finding of best fishing ground and safe navigation.
- 7) Ship's speed and water temperature can be manually calibrated for coherent deviation caused by the sensor or its mounting condition.
- 8) Four picture advance speeds for various fishing conditions.
- 10) Powerful noise limiter ensures interference-free operation on congested fishing grounds.
- 11) Universal 11-40VDC power supply, drawing less than 45W of power.

* Optional position-fixing equipment and speed/temperature sensor device are required.

PICTURE MODE

This unit is continuously producing the following four modes of pictures internally, and you may display one of the modes on the screen at any time you wish. Each mode is explained later on.

ES PICTURE

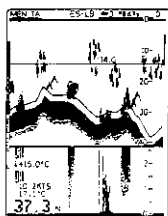

The echo sounder picture is displayed on this mode. Press the [SNDR] key to display the ES picture.

ZOOM PICTURE

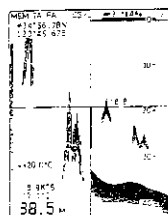

A part of the echo sounder picture can be zoomed up on the left half of the screen and the right half displays a normal echo sounder picture. This mode is useful for detailed observation in midwater fishing. Press the [GR ZM] key to access this mode. "MODE ZM" is temporarily displayed when this mode is selected.

GR PICTURE

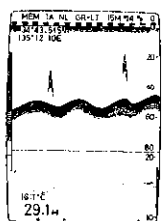

Water temperature is an important factor in locating a desired species of fish, since each species of fish has its own habitable temperature range. This mode displays a water temperature graph and compressed echo sounder display on the upper and lower halves of the screen, respectively. Press the [GR ZM] key to display the GR picture "MODE GR" is temporarily displayed when this mode is selected.

NAV DATA DISPLAY

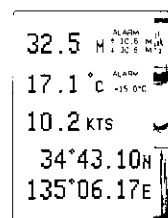

This mode is used to present the navigation data (ship's position, ship's speed, water depth and alarm zones) on the display. Press the [SNDR] and [GR ZM] keys simultaneously to activate the NAV display.

Note that an optional water temperature sensor and position-fixing equipment are required to enable the NAV data display and GR picture.

KEYS AND CONTROLS

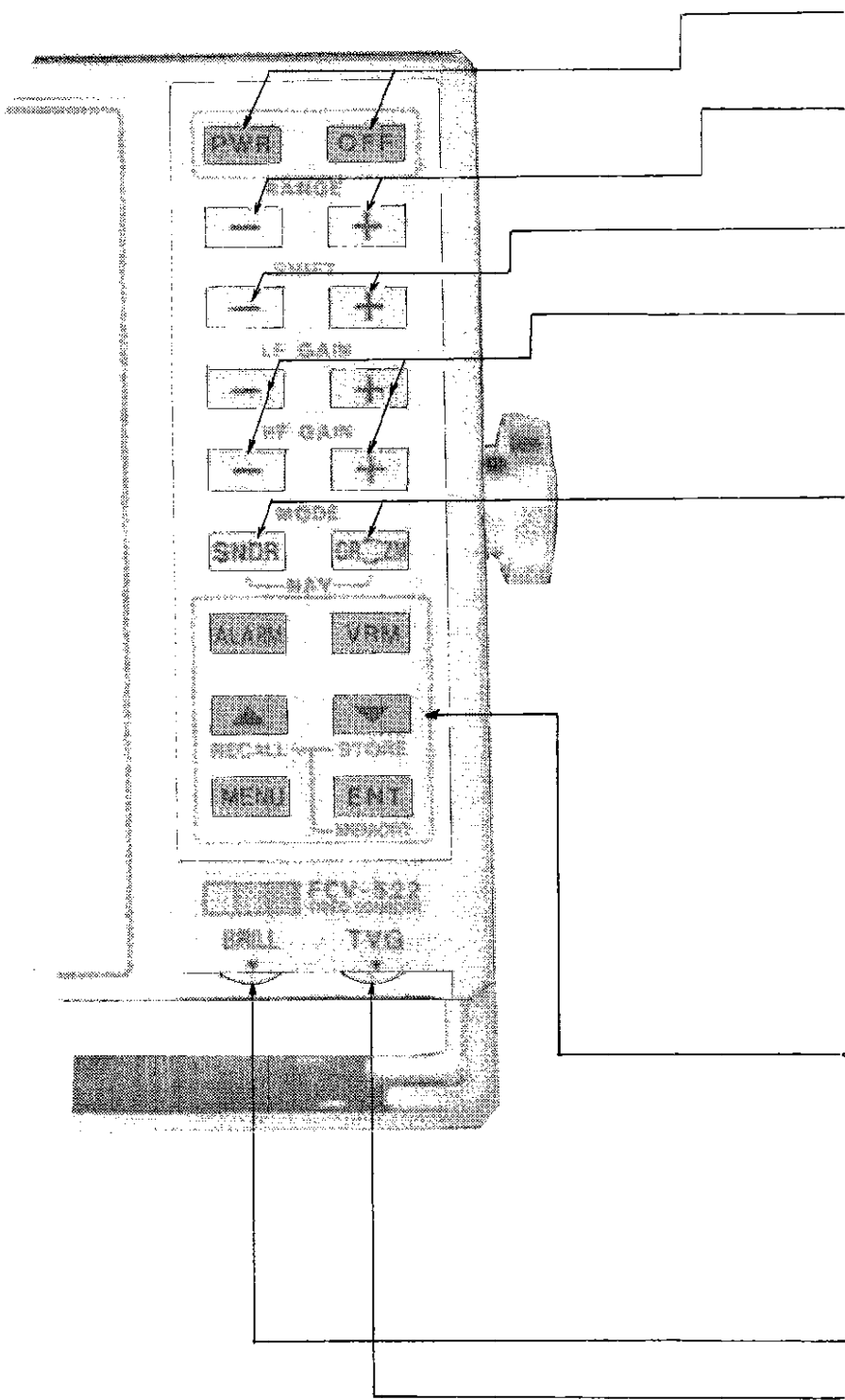

FUNCTION	KEY OPERATION	DESCRIPTION
POWER ON/OFF	PWR PWR OFF	Press the PWR key to turn on the equipment. Press the PWR and OFF keys simultaneously to turn off the equipment.
RANGE	- or + - / + → PWR	Press the - or + key to decrease/increase the basic range. The self-check is performed by turning on the equipment while pressing the - or + key.
SHIFT	- or +	The basic range can be shifted down/up manually with the - or + key. The shifted value is indicated on the screen with "■" symbol.
LF GAIN HF GAIN	- or +	The sensitivity of the receiver can be controlled. Press the - or + key to decrease/increase the gain for LF(50kHz) and HF(200kHz) separately.
MODE	SNDR GR ZM GR ZM SNDR GR ZM NAV	SNDR Picture Page... Echo sounder picture is displayed on this page. The SNDR picture screen is arranged in one of five presentation modes by every pressing of the SNDR key. GR Picture Page Echo sounder picture (LF) is displayed on the upper 2/3 of the screen, and the rest of the screen is utilized to produce the water temperature graph (the optional speed/temperature sensor is required). Since the picture advance speed can be set very low, you may observe long-term transition of underwater conditions and temperature. ZM Picture Page The zoom range is displayed on the left half of the screen and the right half of the screen is utilized for the normal echo sounder picture. Which part of the range is zoomed in is indicated by the white bar displayed at the left edge of the echo sounder picture. (Inoperative on "LB" and "HB" modes.) NAV Picture Page ... Press the SNDR and GR ZM keys simultaneously. The screen is utilized to display the navigational data (water depth, temp., speed, L/L, alarm range) and echo sounder picture (right 1/6). Note: Every time the GR ZM key is pressed, the GR and ZM picture page is replaced.
ALARM	ALARM ALARM + ▲ / ▼	Press the ALARM key to mute the alarm temporarily. To release the mute condition, press the key again. This two-step operation moves the alarm activating bar to your desired position.
VRM	VRM + ▲ / ▼	The VRM marker, which displays depth from the transducer, may be moved up/down with these keys. When the zoom range is selected, the VRM marker shows the display start position.
MEMORY	ENT + ▼ (STORE) ENT + ▲ (RECALL)	The picture on the screen can be stored. Once the memorizing is completed, the preceding picture appears on the screen. The stored picture is recalled on the screen. To redisplay the preceding picture, press the SNDR or GR ZM key.
MENU	MENU	The functions not prepared on the control panel can be set or altered. Press the MENU key and set or alter the function using the ▲ , ▼ and ENT key. To redisplay the preceding picture, press the MENU key again.
BRILL		Adjusts the screen sensitivity.
TVG		Is used to reduce surface noise and provides clear and uniform picture on the screen.

BEFORE BEGINNING OPERATION

This unit is so designed that every user can easily understand its functions soon after it is installed on board the boat. Please note the following basic ideas prior to the first time operation.

FIRST POWER APPLICATION

When first turned on, the unit is started with the following factory settings and displays an echo sounder display. These settings, which are explained on page 14, can be changed on the MENU display according to your operating requirements.

To view the menu display, press the [MENU] key. Press the key again to return to the echo sounder display.

SNDR ADV	: 3	SCALE DSP	: ON
GR ADV	: 15 MIN	B/F ALARM	: OFF
NOISE LIM	: OFF	ALM ZONE	: 1
SHIFT	: MANUAL	TEMP ALM	: OFF
SIG LEVEL	: SL OFF	TEMP LIM	: +15.0°C
HUE	: NIGHT	TEMP ADJ	: +0.0°C
DATA DSP	: ON	SPEED ADJ	: +0%

SUCCEEDING POWER APPLICATIONS

The unit operates with the previous echo sounder settings. This means the last-used RANGE, SHIFTed range, GAIN and Presentation mode are retained by the built-in memory when the power is turned off.

POWER OFF

To avoid unwanted power disconnection, the [PWR] and [OFF] keys must be pressed simultaneously to turn off the unit.

DIP SWITCH SETTINGS

In addition to operation by the front panel keys, controls and menu display settings, a change of factory settings by the DIP switches can be made on the following items. See page 37. The factory settings of the DIP switches are listed below.

Depth Unit	: Foot (for U.S.A.), Meter (for other areas)
Temperature Unit	: °F (for U.S.A.), °C (for other areas)
Temperature Range	: 10°F (for U.S.A.), 5°C (for other areas)
Ship's Speed	: MPH (for U.S.A.), Knots (for other areas)
Preset Brilliance	: Bright
Memory Back-up	: ON
Sensor	: For water temperature sensor (SENS)
Nav Data Format	: NMEA 0183

BASIC OPERATION

This chapter mainly describes the operations required to use the fundamental functions of this color video sounder.

Advanced operation specifically, custom tailoring the unit to meet your specific fishing needs, is done on the MENU display. Thorough knowledge of the basic functions will keep you to use the unit more effectively.

POWER ON/OFF

Press the [PWR] key, and an echo sounder picture appears after the CRT warms up.

Note: The equipment starts with the last-used settings.

To turn off the unit, press the [PWR] and [OFF] keys simultaneously.

BRILLIANCE CONTROL

Turn the BRILLIANCE control clockwise or counterclockwise to increase or decrease the screen brilliance. To extend the life of the CRT, do not increase the brightness of the screen unduly.

PRESENTATION MODE SELECTION

Selecting the presentation mode is very simple, press the [SNDR] key repeatedly until the desired presentation mode indicator is displayed. This key switches the presentation mode in the sequence of "L" for low frequency, "LB" for low frequency + bottom lock, "H" for high frequency, "HB" for high frequency + bottom lock and "LH" for low frequency + high frequency. The selected mode is indicated both permanently, at the top the screen, and momentarily, at the center of the screen.

L → LB → H → HB → LH



"L" or "H"

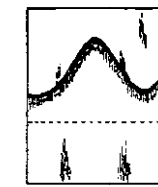

"LB" or "HB"

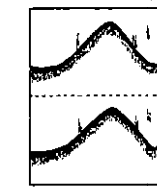

"LH"

Screen Layout

The following are suggested uses for each presentation mode; "L" ("H") for normal fishing in deep (shallow) water, "LB" ("HB") for bottom trawling in deep (shallow) water or "LH" for discrimination of fish species.

Suggestions for selecting a frequency

- 1) High frequency is useful to detect species which do not have air bladders (e.g., sharks) or which are very small and do not readily reflect the echo.
- 2) When the sea is rough, noise (red and reddish colors) heavily covers the surface layer, and sounding is easily interrupted by aerated water which passes below the transducer. It should be noted that a high frequency is less influenced by rough sea when compared with a low frequency. However, in the application where observation of DSL (plankton layer) is paramount, use low frequency because such widely scattered objects are clearly plotted.
- 3) To observe the seabed condition during bottom trawling, a low frequency is preferable because the seabed is plotted thickly and changes of the width can be easily noticed; a wide seabed trace indicates a hard seabed and a narrow trace a soft seabed.
- 4) The "LH" mode offers dual watch of both low and high frequencies. In this mode discrimination of species or fish size is possible through experience. A fish reflects both low and high frequencies, but the proportion of reflection differs from fish to fish. Also, it is widely known that tiny fish reflect high frequencies better than low frequencies.
- 5) Though a high frequency offers a sharp, clear-cut picture, its use should be limited to shallow water fishing because it is easily attenuated in the water.

Bottom Lock Presentation

Selecting the "HB" or "LB" mode provides a compressed normal picture on the upper 2/3 of the screen and a 2.5m (10ft, 1.25fa, 2.0P/B) wide layer in contact with the seabed is expanded onto the rest of the screen with the seabed contour aligned. The range of expansion can be easily recognized on the normal picture because it is marked with a solid line as illustrated right. This mode of presentation is indispensable for bottom trawling.

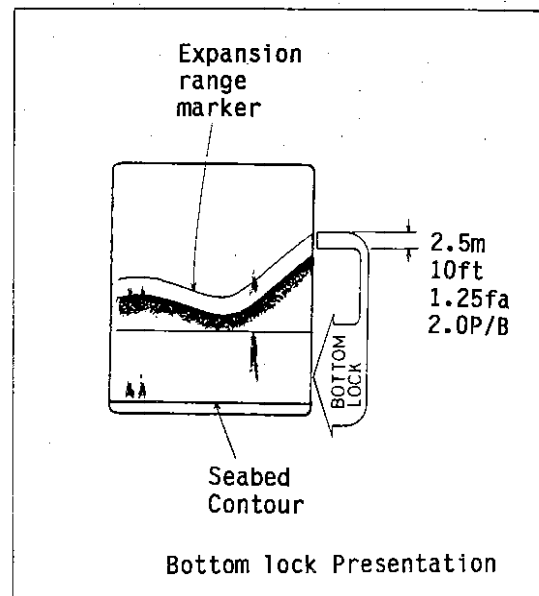

For the bottom-lock presentation, the seabed contour must be steadily and distinctly plotted in red or reddish brown. Adjust the Gain for the best seabed presentation. Too high a setting in shallow water may plot surface noise in reddish color like seabed echo, causing erratic bottom lock operation.

Zoom Display

Pressing the [GR ZM] key once or twice until "GR ZM" is displayed provides a normal picture on the right half of the screen and the zoom display on the left half. "GR-LT" is displayed at the top of the picture. The zoom range bar is indicated on the barrier between the normal and zoom displays. This zoom range bar can be moved up and down by the [▲] and [▼] keys after pressing the [VRM] key. This mode of presentation, which is indispensable for midwater operations, cannot be performed for the presentation modes "LB" and "HB", i.e., bottom lock presentation. The zoom range to each range is tabulated below.

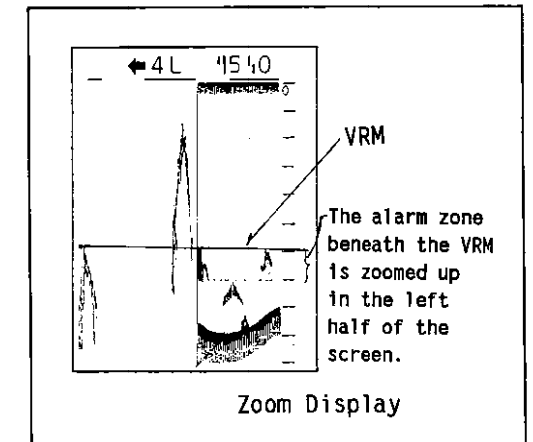

Range	1	2	3	4	5	6	7	8
Meters	4	4	5	10	20	25	50	50
Feet	10	10	20	20	50	100	120	200
Fathoms	2	4	4	5	10	20	20	25
P/B	2	4	4	5	10	20	25	50

P: Passi B: Braza

NORMAL PICTURE RANGE SELECTION

The basic RANGE and range SHIFT [+] and [-] keys allow the operator to select the depth he can observe directly under the boat. The Basic Range can be thought of as providing a "window" into the water column. The start of this window is determined by the setting of the SHIFTED Range selection. For example, if you select Basic Range "5", you will have a 80-meter deep viewing area, which may be moved anywhere in the water column by using the Range Shifting function. To continue our example, if the Shifted Range is set to 15 meters, the top of the range window would be at 15 meters, and the bottom of the range window would be at 80 plus 15 meters.

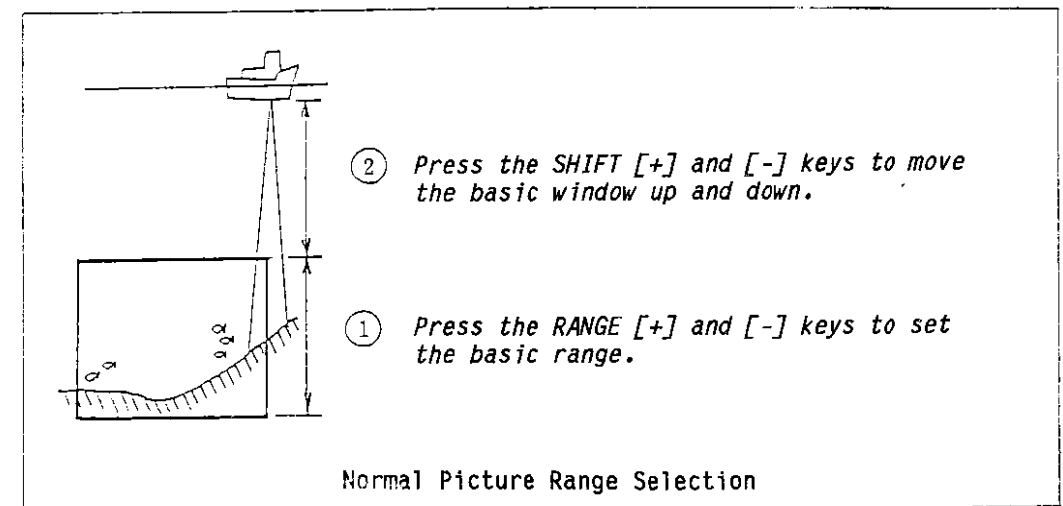

Table of Basic Ranges

Setting	1	2	3	4	5	6	7	8
Meters	5	10	20	40	80	150	200	300
Feet	15	30	60	120	250	500	750	1000
Fathoms	2.5	5	10	20	40	80	120	150
P/B	3	5	10	25	50	100	150	200

P: Passi B: Braza. Unit is changed with internal DIP switches. See page 37.

GAIN CONTROL

Two pairs of GAIN control keys are provided, one for high frequency and one for low frequencies. Each gain control adjusts the sensitivity of the receiver. Normally, the gain is set to the point just below where excessive noise appears on the screen. As a general rule of thumb, use a higher gain setting for greater depths and a lower setting for shallower waters.

(Procedure)

1. Press the GAIN [+] or [-] key, and the present gain setting is displayed at the top left-hand side on the screen. The [+] and [-] keys increase and decrease the gain respectively.
2. If a proper gain cannot be obtained at a short range by the above gain setting, adjust the TVG control together with the GAIN control.



High Gain

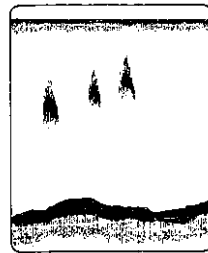

Proper



Too Low

ADJUSTING TVG (Time Varied Gain)

As the range between the transducer and target increases, the amount of power received from the target decreases because it is dissipated on the outward and return journey. To compensate for the propagation loss, the TVG suppresses amplification of echoes at shallow depths and increases amplification as the depth increases.

In addition to compensating propagation loss, the TVG also helps eliminate surface noise which may mask shallow targets. The effective range extends to 50 meters. Set the TVG control between 3 - 5 for normal fishing.

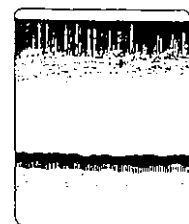

TVG Improper

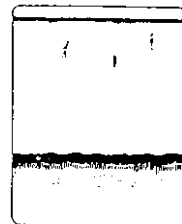

TVG Proper

ALARM (Fish Alarm, Bottom Alarm, Water Temperature Alarm)

This unit is capable of generating three types of alarms: fish alarm, bottom alarm or temperature alarm. These alarms relieve the operator of the need to continuously observe the screen. All alarms are turned on and off on the MENU display (see page 17), and their status can be confirmed by hitting the [ALARM] key.

Fish Alarm/Bottom Alarm

The fish alarm is used to signal that fish are beneath the boat, and bottom conditions are ignored by the alarm. The bottom alarm sounds only when a desired zone between the transducer and the bottom is violated; fish do not trigger the alarm. To set an alarm, first make sure the seabed and fish are properly displayed in red and reddish brown and the desired alarm is turned on at the MENU display. Press the [ALARM] key and move the alarm zone bar, painted in white and located to the left of the scale, to a desired location by operating the arrow keys. (Note that the length of the bar, namely the alarm range, is determined on the MENU display.) When the fish or the seabed which are plotted with more than red and reddish color intensity enter into the specified alarm zone, the audible alarm sounds and a visual alarm, either "FA" (fish alarm) or "BA" (bottom alarm), is displayed in inverse video at the top of the screen. To temporarily disable the audible and visual alarms, press the [ALARM] key.



Alarm Zone

NOTE

- 1) Weak level echoes can not trigger the alarm; the echo must be plotted with more than YELLOW intensity.
- 2) An echo which is plotted within 1m from the zero line can not trigger the alarm.
- 3) When the "LH" (dual frequency) mode is selected, the echo in the low frequency picture serves to trigger the alarm. The high frequency picture is ignored by the alarm.

Water Temperature Alarm

The water temperature alarm function is provided to alert you to changes in water temperature, which can be useful when tracking a desired species of fish. Its function is also set by the MENU display. The audible and visual (TA is displayed in inverse video) alarms can be disabled by pressing the [ALARM] key.

INDICATORS

ES PICTURE

As most of the indicators have been explained in connection with the keying operations, explanation is given to only a few items.

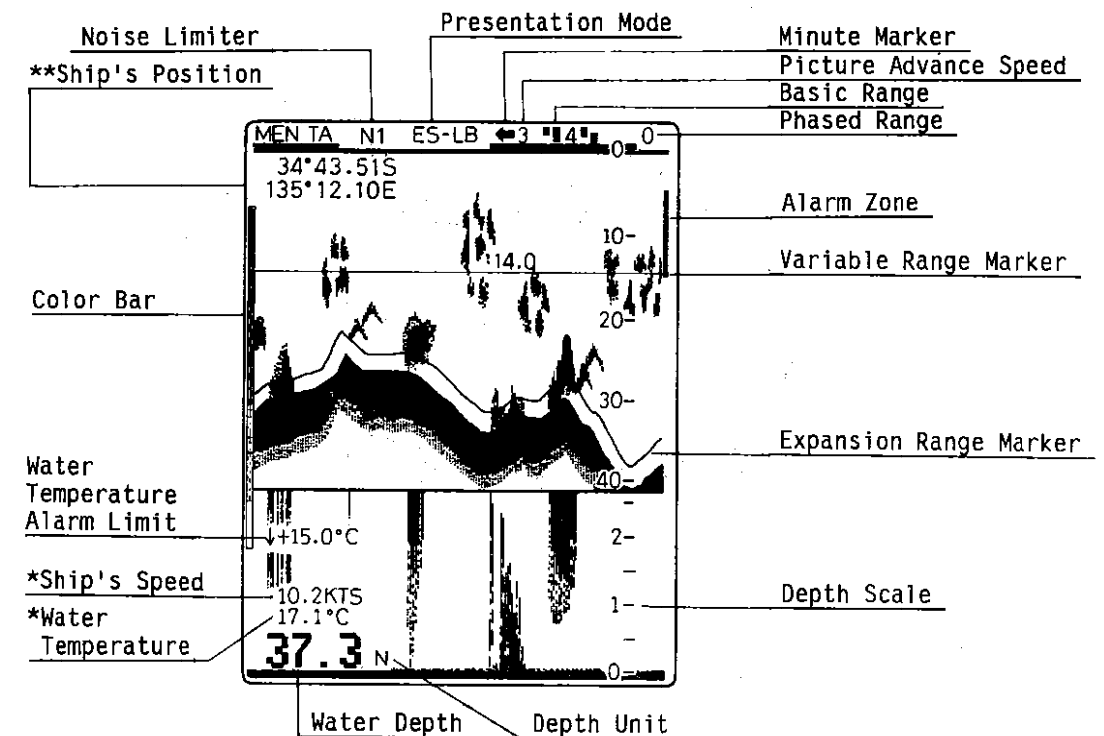

- * Optional speed/temperature sensor required.
- ** Position fixing equipment required. (Readout is not provided while the CYC or SNR lamp of the connected Ioran navigator is on.)
- Color Bar** : Gives reference of color gradation; reddish to bluish color for strongest to weakest echo return.
- Minute Marker**: One complete minute is shown with a 30 sec. horizontal bar and 30 sec. blank space. By observing the number of minute marks on the screen, you can determine the amount of history being displayed on the screen.
- Water Depth** : This indicator shows the depth from the transducer to the seabed. The unit is capable of reading depths beginning from 1m below the transducer. This minimum depth is necessary to prevent locking onto the surface turbulence rather than the bottom. In order to obtain depth readout, the bottom must be displayed on the screen. Correct depth readout is displayed even when the picture advance rate is set to "0."

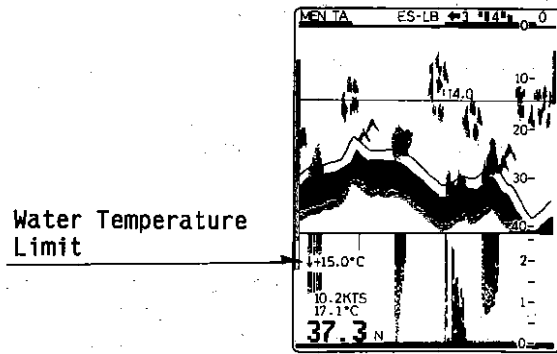

TARGET DEPTH MEASUREMENT BY VRM (Variable Range Marker)

The green horizontal line is the Variable Range Marker. This line is used to locate the target to measure the depth to it. To measure the range to a target, press the [VRM] key, and the indication "VRM" is displayed temporarily. Then press the arrow keys to move the marker to the location desired. The depth of the marker is digitally indicated.

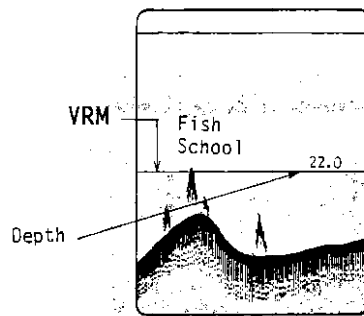

PICTURE STORE/RECALL

This function allows you to store a currently displayed picture for reference, and redisplay it when desired. To store a picture, press the [ENT] key, and the message "MEMORY" is indicated. Next press STORE [▼] key, and the currently displayed picture is stored for reference after displaying "MEMORY" once again. A picture is stored on a first-in, first-out basis; a stored picture will be erased to make room for a new picture each time the above operation is performed. To recall a stored picture, press the [ENT] key and RECALL [▲] keys in order. The recalled picture and the indication "MEM" are displayed. To return to normal operation, press the [SNDR] or [GR ZM] key.

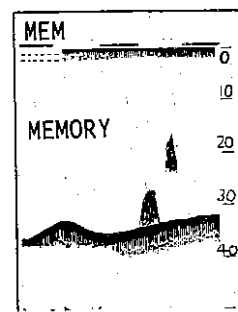

GR(Water Temperature Graph) PICTURE

This picture plots a history of echograms and water temperature graph during the period which is preselected on the MENU display. See page 15. This picture is useful to detect a thermocline caused by a sudden change of water temperature where fish collects and expects a good catch. To display this picture, press the [GR ZM] key once and twice.

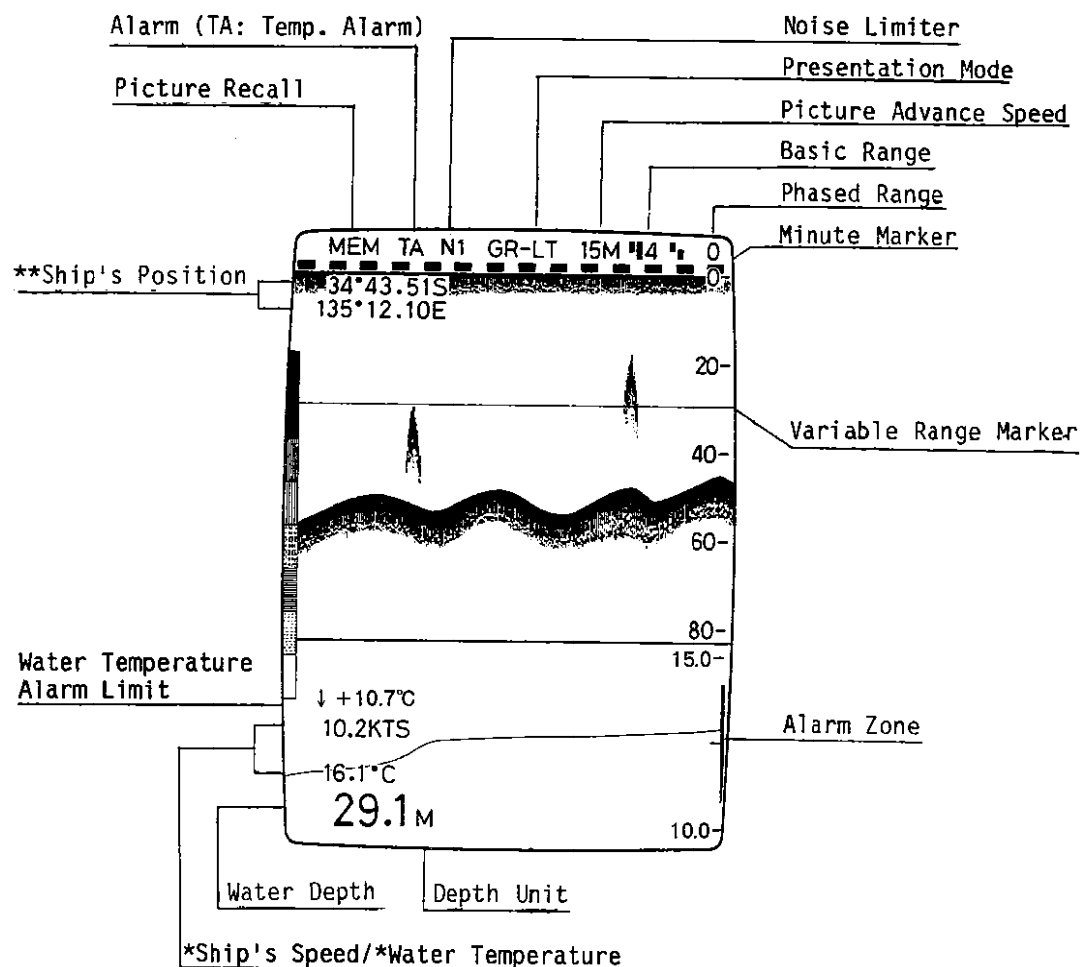

NAV DATA DISPLAY

This display can be referenced at any time to ensure water depth, water temperature, ship's speed, fish/bottom alarm zone and temperature alarm setting. To display this display, press the [SNDR] and [GR ZM] keys simultaneously. To return to the echo sounder picture or the GR picture, press the [SNDR] key or the [GR ZM] key.

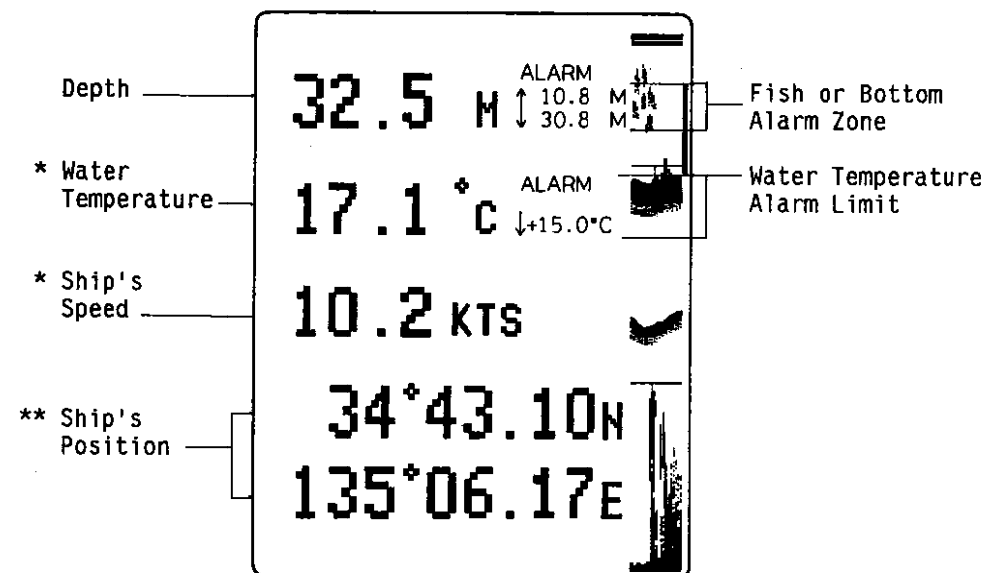

* Optional speed/temperature sensor required.
 ** Position fixing equipment required. (Readout is not provided while the CYC or SNR lamp of the connected loran navigator is on.)

* Optional speed/temperature sensor required.
 ** Position fixing equipment required. (Readout is not provided while the CYC or SNR lamp of the connected loran navigator is on.)

Water Temperature: The display range is from -5° to +35°C(or -10°F - +95°F). The temperature scale automatically changes in 5°C or 10°F steps when the temperature reaches upper/lower limit of the displayed scale.

ADVANCED OPERATION

Basic operation of this unit is normally carried out with the front panel keys and controls. For advanced operation, factory settings can be changed, on the MENU display, to accommodate your specific needs. Frequent alteration however is not recommended since it can result in misinterpretation of the echogram.

FACTORY SETTINGS

The factory settings are shown on page 4. These settings can be changed as explained below. If the unit cannot operate in a wanted state after change of the factory settings, restore the factory settings again.

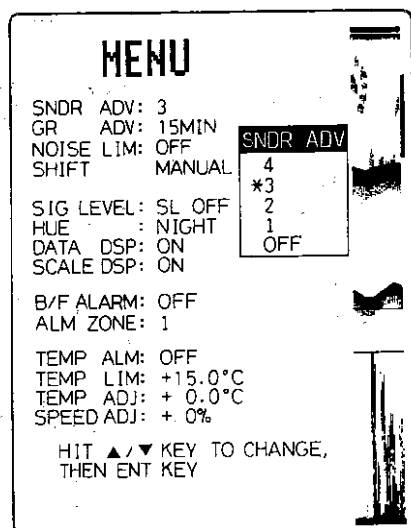

GENERAL MENU SETTING PROCEDURE

All menu items can be changed by the following sequence:

- 1) Press the [MENU] key, and the menu display appears on the screen.
- 2) Select the menu item by pressing the [▲] or [▼] keys followed by the [ENT] key, and the sub menu display appears.
- 3) Select the desired setting by pressing the [▲] or [▼] key followed by the [ENT] key.
- 4) To return to the previous display, press the [MENU] key.

PICTURE ADVANCE SPEED

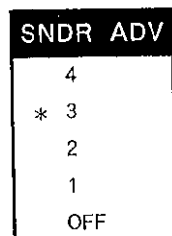

This sub menu is used to set picture advance speed. As the picture is built up one scan line at a time, from right to left across the screen, the amount of the time you can observe the same echo is directly related to the picture advance speed. The "OFF" position freezes the picture advancing and the "4" position allows fastest advance speed. At this position, the size of the fish is expanded horizontally across the screen.

GR PLOTTING SPEED

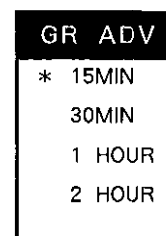

This sub menu sets the period to complete a full GR screen picture; 15 minutes, 30 minutes, 1 hour, 2 hours.

NOISE LIMITER

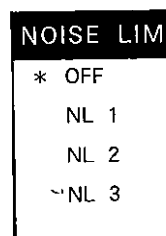

When the interference from other echo sounders operating nearby or other types of electrical interference exist, you may use the noise limiter to eliminate or reduce the interference. The "OFF" position turns off the noise interference function. Position "NL 3" affords the highest degree of noise rejection. The status of the noise limiter, (OFF) N1, N2, N3 or no display, is indicated on the echo sounder picture.

Note: If the noise limiter is left in N3 when no interference exists, weak echoes may be missed or eliminated.

SHIFT MODE

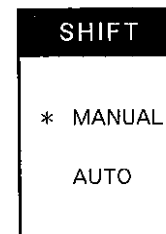

The basic range window can be shifted manually by the front panel SHIFT [+] and [-] keys. This menu allows selection of automatic bottom tracking feature at the "AUTO" position.

Automatic Bottom Tracking

The automatic bottom tracking function shifts the basic range window up and down automatically to track the seabed on the lower half of the screen. The basic range windows jumps up when the seabed trace rises up over the center of the normal picture, and jumps down when it disappears from the lowest limit of the picture. The step of jumping is 1/4 of the basic range in use.

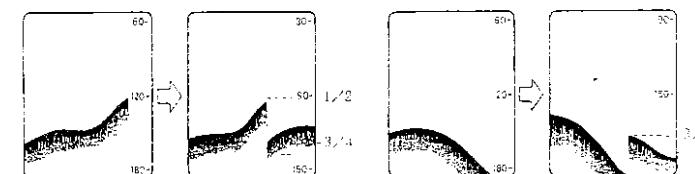

- Note:*
1. The indication "AUTO" appears at the top of the ES picture.
 2. When the seabed return becomes weak, the AUTO function is disabled and the basic range scale keeps on shifting to search for seabed echoes. To continue the AUTO mode, increase the GAIN for stable reception of the seabed.
 3. The manual shifting is disabled during the automatic bottom tracking.

THRESHOLD (SIGNAL LEVEL)

SIG LEVEL
 * SL OFF
 SL 1
 SL 2
 SL 3

The threshold (signal level) sub menu is used for eliminating low intensity echoes in three steps of SL1, SL2 and SL3 over the entire screen. SL1 for blue, SL2 for light green and SL3 for green color echoes.

BOTTOM ALARM AND FISH ALARM ON/OFF

B/F ALARM
 * OFF
 BA
 FA

This unit can generate a fish alarm or bottom alarm, as well as a temperature alarm. This menu allows selection among OFF, BA for bottom alarm and FA for fish alarm.

COLOR SELECTION FOR DAY AND NIGHTTIME OPERATION

HUE
 * NIGHT
 DAY

This color sounder paints targets in 7 or 5 colors in accordance with the echo strength. Select either NIGHT (7-color presentation, background in LIGHT BLUE) or DAY (5-color presentation, background in DEEP BLUE) position to meet your operating environment.

ALARM ZONE

ALM ZONE
 1/3
 1/2
 * 1
 2
 3

This sub menu is used to set the alarm zone range. The alarm zone range is a function of the alarm zone setting and unit value of the range in use. For example, if the alarm zone setting is 2 and the unit value of the range in use is 5m (see the table below), the alarm zone range would be 10m (5m x 2 = 10m), which can be moved anywhere within the range in use.

Unit Value of Alarm Zone

Range	Meters	Feet	Fathoms	P/B
1	1	3.75	0.5	0.5
2	2	5	1	1
3	5	20	2	2
4	10	20	5	5
5	20	50	10	10
6	25	100	20	25
7	50	125	20	25
8	50	200	25	50

DATA DISPLAY

DATA DSP
 OFF
 * ON

This sub menu allows switching the data display of water temperature, ship's speed and ship's position on and off. This function is disabled on the NAV display which shows all navigation data.

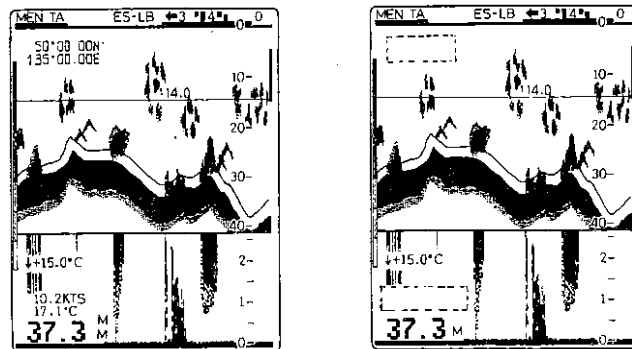

WATER TEMPERATURE ALARM

TEMP ALM
 * OFF
 ↑ UP
 ↓ DOWN

The water temperature alarm can be activated by the TEMP ALM menu and its alarm zone set by the TEMP LIM. UP and DOWN positions set the alarm to be activated for water temperature higher and lower than the value set by the TEMP LIM menu respectively. The TEMP LIM range as indicated on the top line of the TEMP LIM sub menu and the current setting below it. Setting can be changed with the arrow keys.

SCALE DISPLAY

SCALE DSP
 OFF
 * ON

This sub menu switches the display of the depth scale on and off.

TEMP LIM
 -5 : +35
 * +15.0°C

WATER TEMPERATURE CALIBRATION

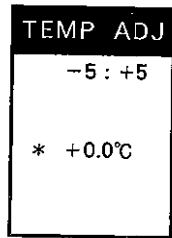

The TEMP ADJ menu allows calibration of water temperature indication between + or - 5°C (or 10°F). This deviation is caused by the characteristics and mounting state of an optional water temperature sensor. Press the [▲] and [▼] keys to change the value.

SHIP'S SPEED CALIBRATION

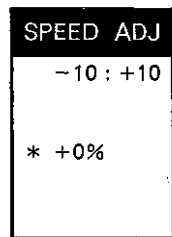

The SPEED ADJ menu allows calibration of ship's speed indication between -10 and +10%. This deviation is caused by the characteristics and mounting state of an optional ship's speed sensor. Press the [▲] and [▼] keys to change the value.

INTERPRETING THE DISPLAY

Using some typical examples, this section describes how to interpret the echogram.

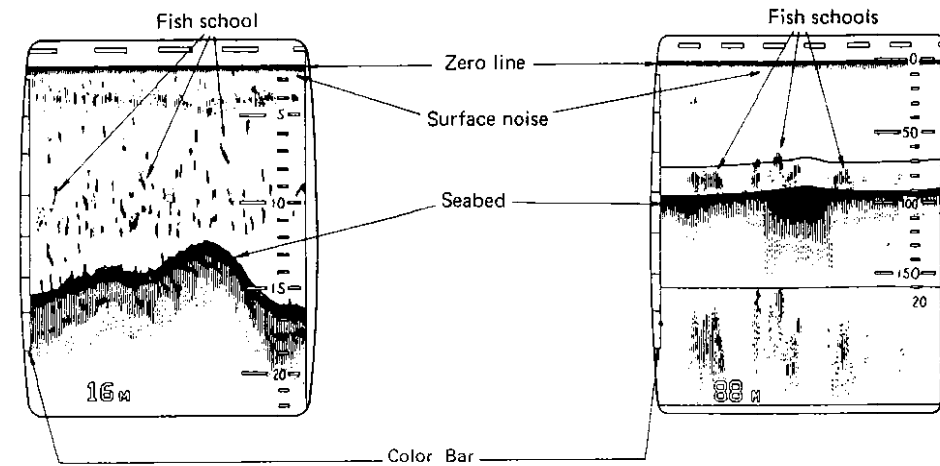

COLOR BAR

The color bar shows the relation between the echo intensity and the echo color on the screen. The top color (reddish brown) is used for the strongest echo and the lower colors for the weaker echoes. It can be used as a reference to estimate fish school density, fish species and hardness of seabed.

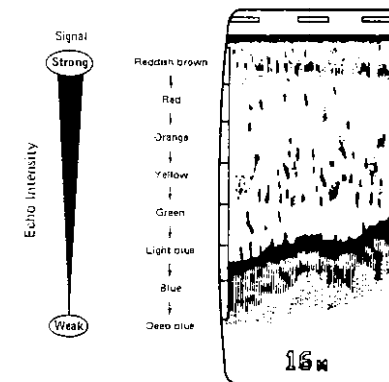

The number of colors can be changed from 8 to 6 with the MENU screen. See page 16.

ZERO LINE

The zero line represents the transducer's position, and moves off the screen when a phased range is used.



SEABED

Seabed echoes are normally strong and displayed in reddish brown or red, but colors and width will vary with bottom material, water depth, frequency, pulselength, and sensitivity.

BOTTOM PROFILE

A hard and rough seabed appears with a longer tail because it reflects more of the ultrasonic pulse. Because of their stronger return, shallow seabed echoes appear wider than deep ones even when all bottom conditions are equal. Also, a longer seabed tail appears on slopes because of the difference in travelling time at both edges of the beam angle.

In the rugged bottom, echoes are reflected on many different planes, overlapping to present a three-dimensional effect.

BOTTOM NATURE

The nature of seabed is known from the intensity and length of the seabed tail. Generally, when observing the seabed nature, lower sounding frequency is used, the pulselength is set to long and the gain setting is kept unchanged.

In the hard and craggy bottom, the seabed appears in reddish brown with a long tail.

In the muddy or sandy bottom, the echoes appear less reddish and with a short tail. However, the bottom with sediment may give a long tail if a low frequency sounding is used.

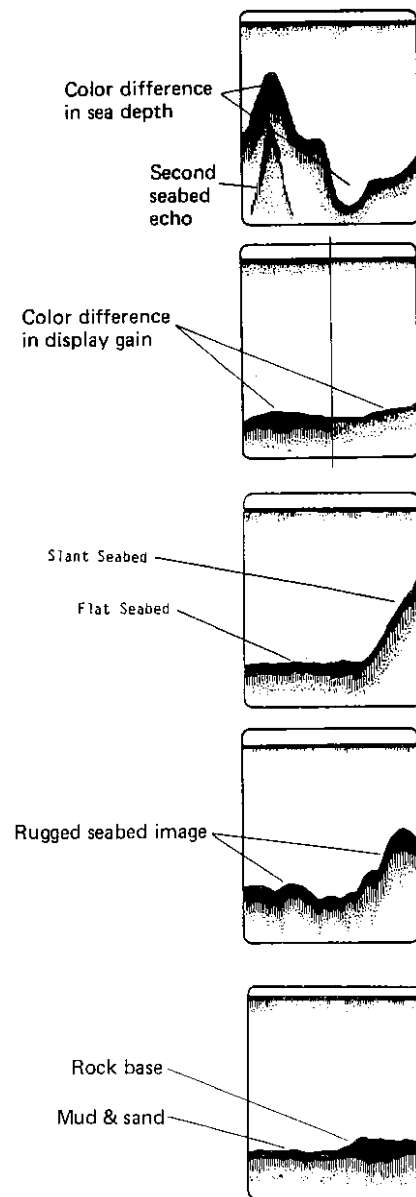

FISH SCHOOLS

FISH QUANTITY

The fish quantity can be estimated to a certain extent from fish echoes on the screen if the following two basic characteristics are kept in mind.

Size of Fish School

Usually the size of fish echoes on the screen is proportional to the actual size of fish school. However if two fish echoes appear at different depths with the same size, the fish school at shallower depth is larger because the ultrasonic beam widens as it propagates and fish school in deep water is displayed larger.

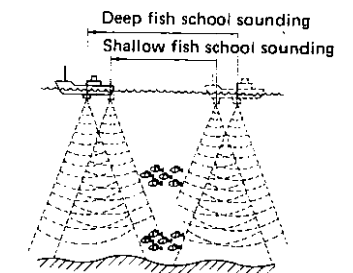
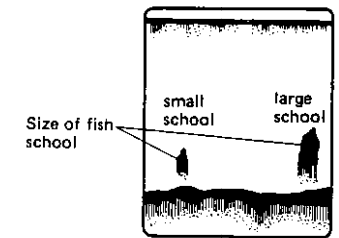

Density of Fish School

If two fish schools appear with the same color at different depths, the one at a deeper water is denser because the ultrasonic wave attenuates as it propagates and the fish school in deep water tends to be displayed in a weaker color.

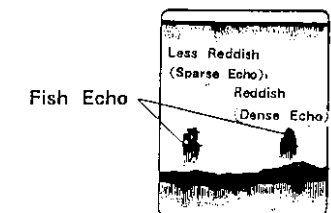

BOTTOM FISH

Bottom fish can be easily distinguished from the seabed because both are displayed in different colors. Thus, a white line is not required as it is with a recording paper echo sounder.

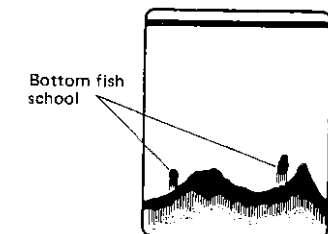

PLANKTON/CURRENT RIP

Plankton

A plankton layer, a likely place to find fish, is displayed in green or blue dots. It usually descends in the day and rises at night.

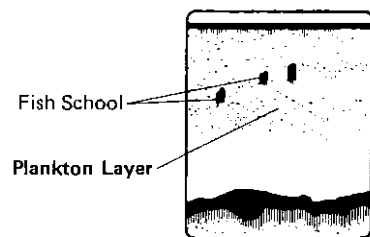

Current Rip

If two ocean currents meet with different speeds, directions and water temperatures, a current rip is developed. Since plankton and air bubbles collect there, it is displayed as shown at right.

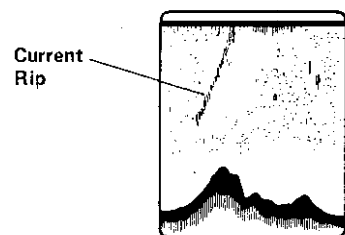

SURFACE NOISE

When the sea is rough or the ship passes over a wake surface noise may appear. Adjust the TVG or SIGNAL LEVEL to clear surface clutter.

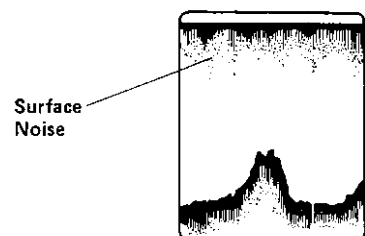

AERATION

When the sea is rough or the ship makes a quick turn, the echogram is occasionally interrupted due to air bubbles blocking propagation of wave. Generally low frequency waves are interrupted more easily than high ones.

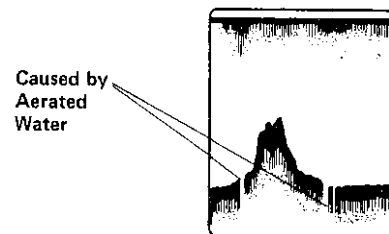

ZIG-ZAG BOTTOM

The bottom contour zig-zags when the ship rolls and pitches heavily because the sounding direction fluctuates and the distance to the seabed varies.

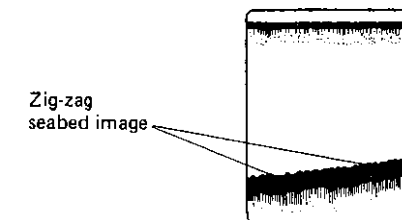

FALSE IMAGE

The following false echoes are detected by the sidelobe of the ultrasonic wave:

- * above seabed contour at steep rising
- * below seabed contour in shallow water

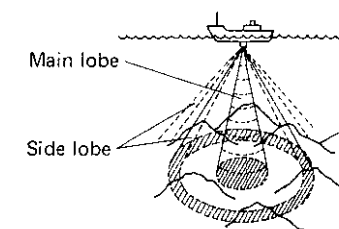
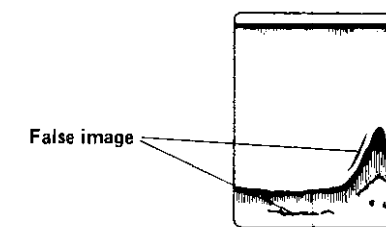

INTERFERENCE

Interference (from ship vibration, engine noise, electric equipment, other echo sounders, sonar etc.) may sometimes appear on the screen. Most interference can be rejected by the Noise Limiter. See page 15. Interference appearing at the same interval or near the transmission keying rate may not be rejected.

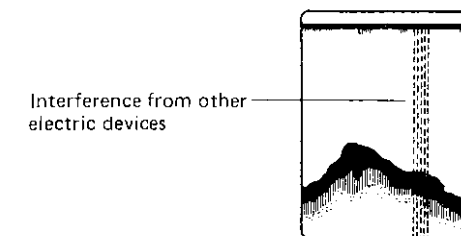
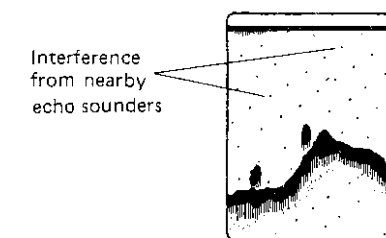

IF SOMETHING SHOULD GO WRONG WITH YOUR UNIT

If the unit does not operate properly, perform the following Operation Check to determine whether your unit is really defective. If the problem cannot be alleviated, proceed to the System Diagnosis section (P.27) to track down the cause of the problem. Should service be required, report the results of the check to the service technician.

OPERATION CHECK

Nothing Appears

- * Check fuse (5A) on the rear panel.
- * If nothing appears (power cannot be applied) after replacing the fuse, request service.

No Echo Presentation, But Scale Shows

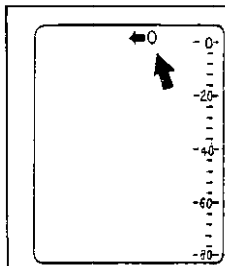

- * Is the PICTURE ADVANCE SPEED set to "0" (freeze)?
- * Is the combined echo sounder properly operating (when the FCV is used as a slave monitor)?

No Zero Line

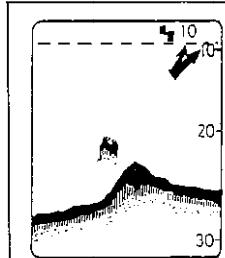

- * Is the PHASED RANGE reading "0"?

Low Sensitivity

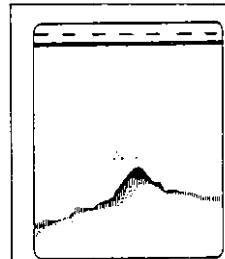

- Are the GAIN and the TVG controls properly set?

Multiple Seabed Traces

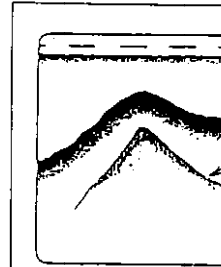

- * Is the water shallow?

Second seabed trace appears in shallow waters due to multiple reflections between the surface and the seabed.

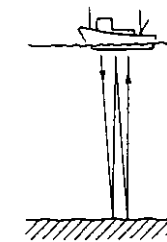

Zigzagged Seabed Trace/Occasional Loss of Echo Plotting

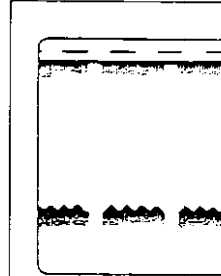

- * Is the sea rough?

Zigzagged seabed trace is plotted when the boat pitches and rolls.

When the boat passes through aerated water, propagation of sound wave is blocked, causing loss of echo plotting. This often occurs when the boat goes astern, or when crossing a wake.

No Water Depth Readout/Bottom-lock Inoperative

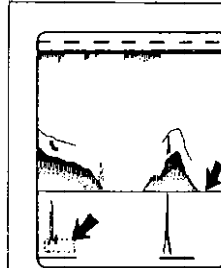

- * Is the seabed echo present within the normal picture range?
- * Is the seabed return strong enough; i.e., red or reddish brown?

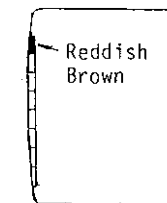

Automatic Bottom Tracking Inoperative

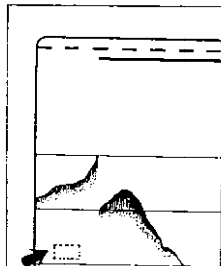

- * Is the seabed return strong enough; reddish brown or red.

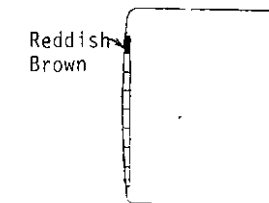

Picture Distorted

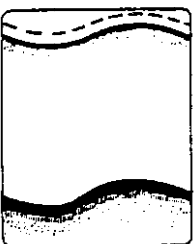

* Is a magnetic field generator (heavy duty transformer, rectifier, etc.) nearby?

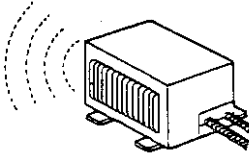

Different Color Picture or Marker



* Is the BRILLIANCE control set properly?
* Confirm that the display color for day or night operation is properly set.

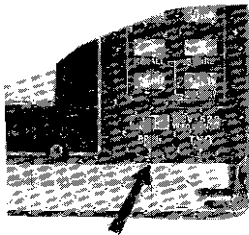

Color Impurity in a Particular Area



* Magnetic field generator nearby?
* Turn the POWER off and on for degaussing. If not completely cleared, call for repair.

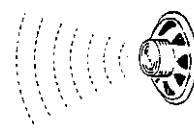

Occasional Disturbance and Random Noise



* Are the connection cables laid near equipment or cables that generate noise? If so, separate them.

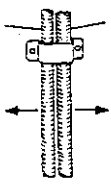

Heavy Noise and Interference

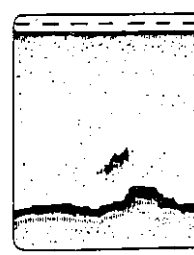

* Is the GAIN set properly?
* Is the equipment properly grounded with a copper wire?
* If this occurs only when vessel is moving, has transducer been faired-in properly?

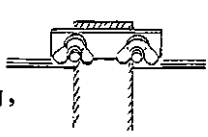

SYSTEM DIAGNOSIS

Your unit is provided with self-check facilities which may be initiated by the following operation:

- (1) Turn off the power pressing the PWR and OFF keys at the same time.
- (2) While pressing and holding the \square or \square key of the RANGE key, press the PWR key.

In a few seconds the self-check program is displayed.

Program Number

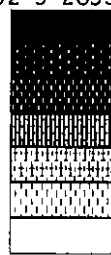
M 02-5-2032-00	* KEY	PANEL SWITCH CHECK
S 02-5-2033-00	0 - \square + 0	While "*" is displayed besides "KEY", the function of each key can be checked. Operate each key while observing the screen. ("ON" \rightarrow 1, "OFF" \rightarrow 0)
	0 - \square + 0	FUNCTION/DEVICE CHECK
	0 - LG + 0	
	0 - HG + 0	Pressing the [ENT] key moves the "*" to the item "PULSE", which indicates the function/device check. In the DRAM check, the entire screen is painted REDDISH BROWN and WHITE four times and finally check result is given. If everything is normal, "OK" is indicated. If something is wrong, "OK" is not displayed.
	0 SNDR GR 0	
	0 ALM VRM 0	
	0 \blacktriangle \blacktriangledown 0	
BUP ON	0 MENU ENT 0	
UNIT M	PULSE OK	
NAV SIG NMEA	CIF OK	
TEMP INT SENS	SPEED	
UNIT TEMP °C	TEMP	
UNIT SPD KTS	EROM OK	
RNG TEMP 5°C	SRAM OK	
	DRAM OK	

Indication of the internal settings.

(See page 37.)

NOTE:

CIF can be checked in the factory only using a special connection cable. In the field, no indication is normal.
The SPEED and TEMP check shows actual ship's speed and water temperature, when a speed/temperature sensor is connected. Nothing is displayed otherwise.

- (3) To terminate the system diagnosis, turn off the power pressing the PWR and OFF keys at the same time.

INSTALLATION

DISPLAY UNIT

Install the display unit at such place,

- . at least one meter away from magnetic field-generating devices.
- . not exposed to direct sunlight and water splash.
- . no electrical noise and interference.
- . away from radiotelephone and its feeder cable.

Allow service/ventilation space indicated below.

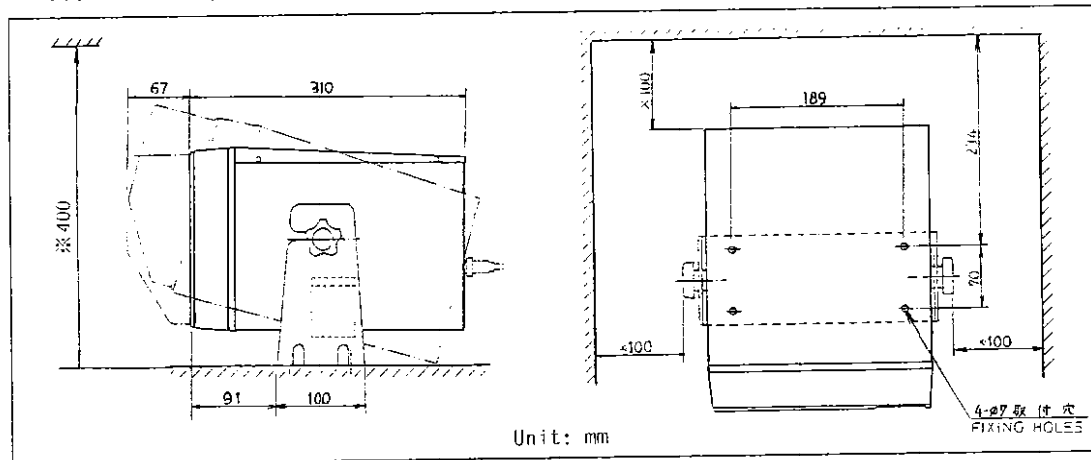

Mounting Procedure

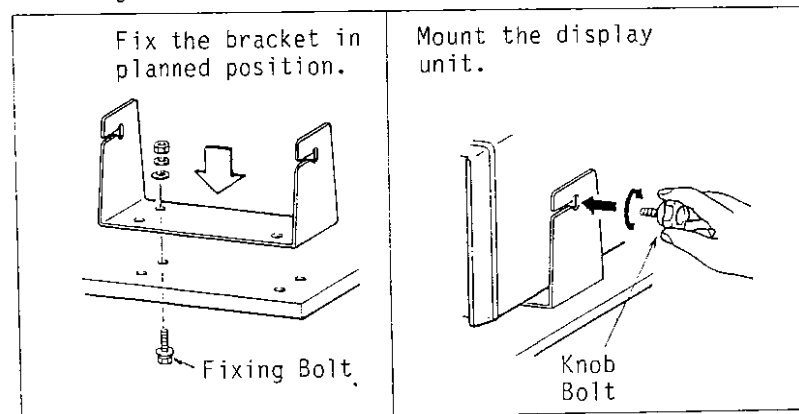

NOTE: OVERHEAD MOUNTING ALLOWED, BUT NO BULKHEAD MOUNTING.

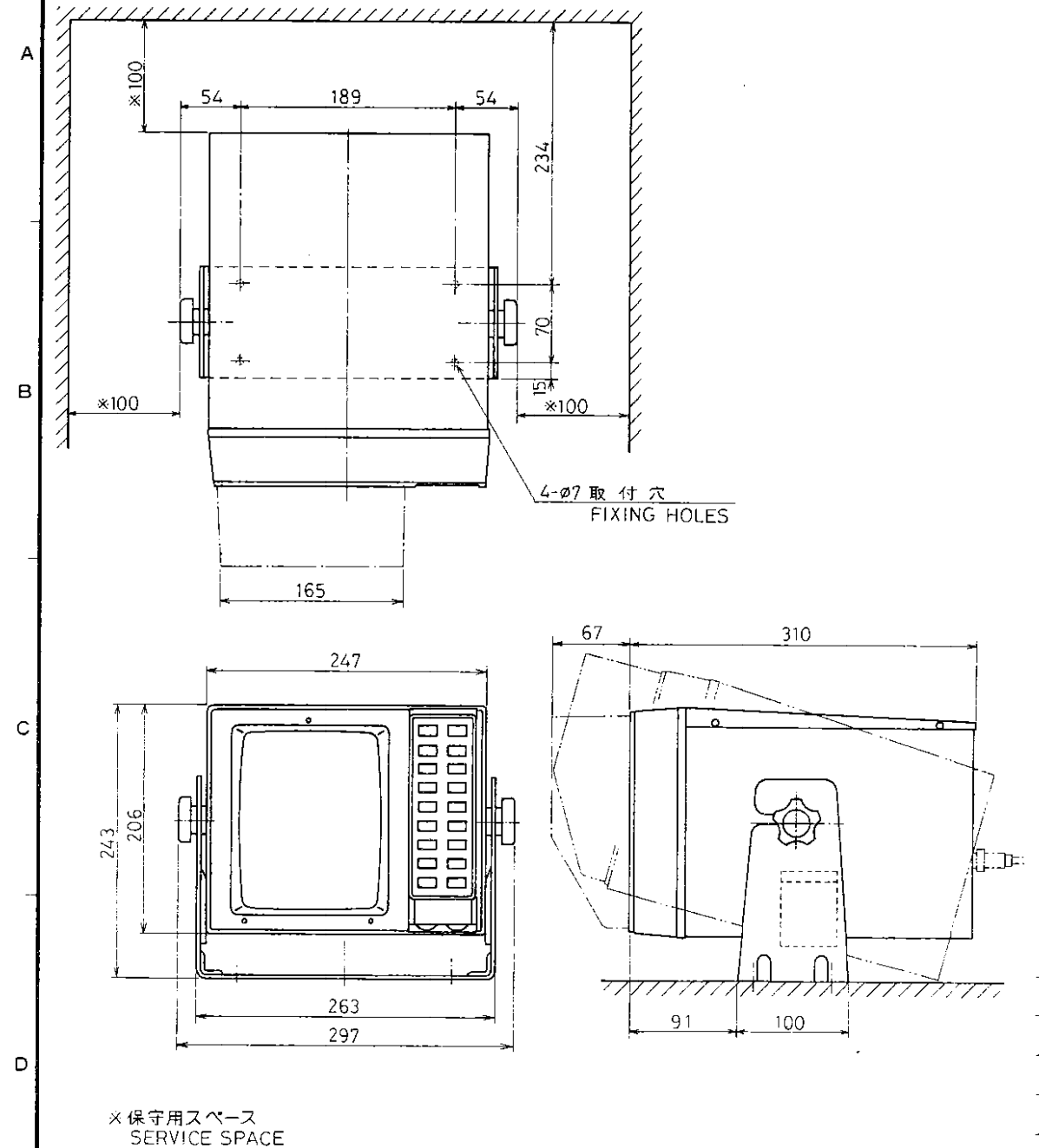

品番 ITEM	品名 NAME	材質 MATERIAL	数量 Q'TY	図番 DWG.NO.	摘要 REMARKS
承認 APPROVED	MAY. 15. 87 T. NAKANO	三角法 THIRD ANGLE PROJECTION			名称 TITLE
検図 CHECKED	MAY. 13. 87 T. KOHJI	尺度 SCALE	1/5		FCV-522 指示器 DISPLAY UNIT
製図 DRAWN	MAY. 13. 87 M. USUDA	重量 WEIGHT	8 kg	図番 DWG.NO.	C2317-008-A

TRANSDUCER

The FCV-522 is available with either a transom mount, inside-hull mount or through-hull mount transducer. This section of the manual shows the installation procedure for each transducer.

The performance of this video sounder is directly related to the mounting location of the transducer, especially for high-speed cruising. The installation should be planned in advance, keeping the standard cable length (8m) and the following factors in mind.

- 1) Air bubbles and turbulence caused by movement of the boat seriously degrade the sounding capability of the transducer. The transducer should, therefore, be located in a position where water flow is the smoothest. Noise from the propellers also adversely affects performance and the transducer should not be mounted nearby. The lifting strakes are notorious for creating acoustic noise, and these must be avoided by keeping the transducer inboard of them.
- 2) The transducer must always remain submerged, even when the boat is rolling, pitching or up on a plane at high speed.

For displacement hulls, using inside-hull and through-hull installations, a practical choice would be somewhere between 1/3 and 1/2 of the boat's length from the stern. For planing hulls, a practical location is generally rather far astern, so that the transducer is always in the water regardless of the planing attitude.

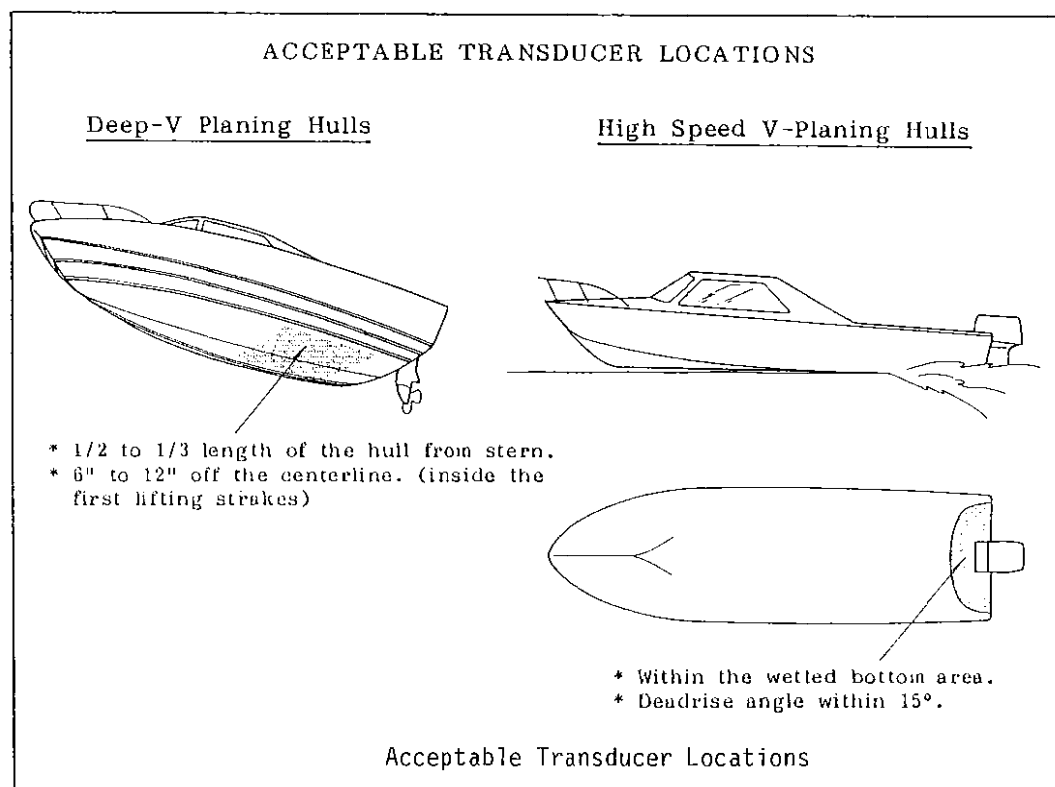

TRANSOM MOUNT

This type of mounting is very commonly employed, usually on relatively small I/O or outboard boats. Do not attempt this mounting on an inboard boat due to turbulence created by the propeller ahead of the transducer.

1. Attach the transducer to the bracket as shown on the next page.
2. To determine a suitable transducer mounting location, run the boat at several speed ranges and observe the water flow at the rear and near the transom. Suitable location is at least 50 cm (18") away from the engine and where the water flow is smooth.
3. On a relatively flat hull, the transducer is mounted flush with the hull-bottom, and there are two choices of installation as shown on the next page. Note that the direction of the transducer and its fixing holes on the brackets are different for each method. Although there is less influence from air bubbles with method (b), you must be careful not to damage the transducer when the boat is hauled out of the water/put on a trailer. On a deep "V" hull, the transducer is mounted in the same manner as method (b) for the flat hull. It should be mounted as near as the bottom edge of the transom, and the transducer face must be parallel with the seabed, not with the hull bottom.

The temperature/speed sensor ST-01PTB can be directly attached to the transducer as shown on page AP-1, provided that the transducer is mounted in method (b). If method (a) is taken, the sensor should be mounted separately.

4. Mark the screw locations by holding the transducer in position on the transom.
5. Drill four pilot holes for the mounting screws.
6. Mount the transducer and secure it with four self-tapping screws. A small amount of sealing compound under the head of each screw will preserve the watertight integrity of the transom.
7. Adjust the transducer position so that the transducer faces right the seabed.
8. If necessary, to improve water flow and minimize air bubbles staying on the transducer face, incline the transducer about 5° at the rear. This may require a certain amount of experimentation for fine-tuning at high cruising speeds.
9. Fill the gap between the wedge front of the transducer and transom with epoxy material to eliminate any air spaces.

When the transducer with a speed/temperature (molded in one unit) is installed, follow the method (2) on the next page.

INSIDE-HULL MOUNT

While this is by no means an optimum mounting scheme for deep-water sounding, this type of mounting can sometimes be used on fiberglass boats. A transducer can be likened to an antenna used with a TV set. Mounting an antenna inside your attic is like mounting an echo sounder transducer inside the hull. Both will work well enough, but are hardly optimum for either TV or echo sounder operation. In addition to the general considerations described on page 30, it is important to ensure that the transducer be placed in an area that has a single-hull thickness and is void of air or flotation materials other than solid fiberglass between the transducer face and the water. Also, the transducer face should not be placed over hull struts or ribs which generally run under the hull. Further, a location where the rising angle of the hull exceeds 15° should be avoided to minimize the effect of the boat's rolling.

It is advisable that the mounting location be finalized through a little trial and error after all other installation works have been completed. Temporarily put some silicone grease (not the type that sets up after drying!) inside the hull. Push the transducer down to squeeze out any air bubbles. Turn on your unit. Run the boat at various speeds and move the transducer to different locations to select the position where the best picture is obtained. Once a good location is found, you may permanently mount the transducer.

The inside-hull mounting is accomplished as follows. See page 35 for outline drawing.

1. Lightly roughen the transducer face with fine #10 sandpaper and degrease it with a solvent (thinner or alcohol). Also, roughen and degrease the inside of the hull where the transducer is to be mounted.
2. Allow both to dry completely, then coat the transducer face and hull with the adhesive supplied. In a cold environment, you should warm the adhesive to approximately 40°C before usage to soften it.
3. Press the transducer firmly down on the hull and gently twist it back and forth to remove any air which may be trapped in the adhesive. Allow sufficient time for the adhesive to dry.

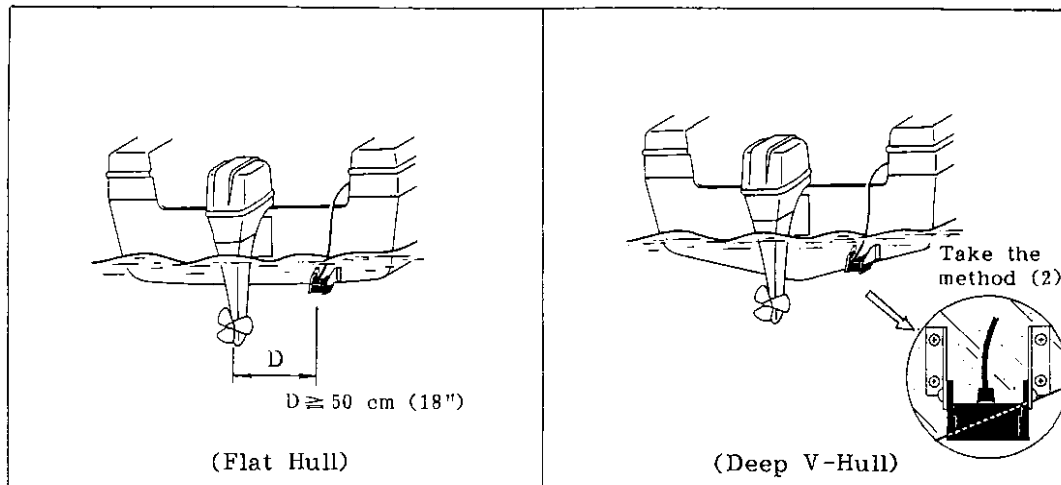
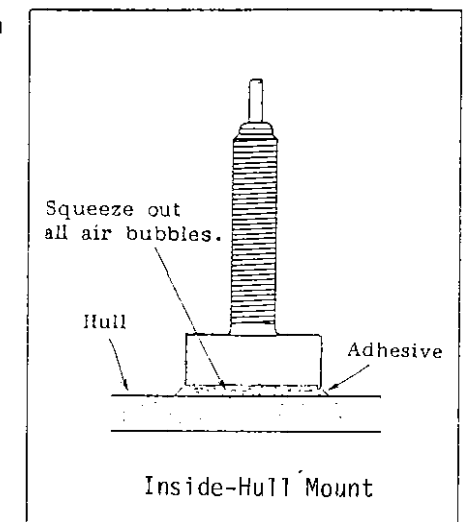

METHOD (1) ... flush with hull

Cover the gap between transducer and hull board with tape. Fill in with epoxy materials and wait until dry. When dry, remove tape.

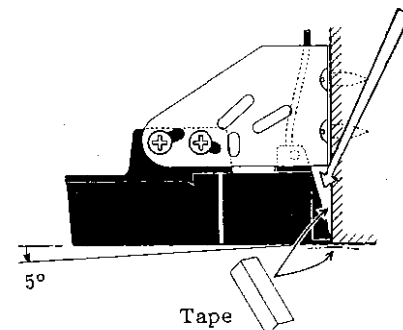
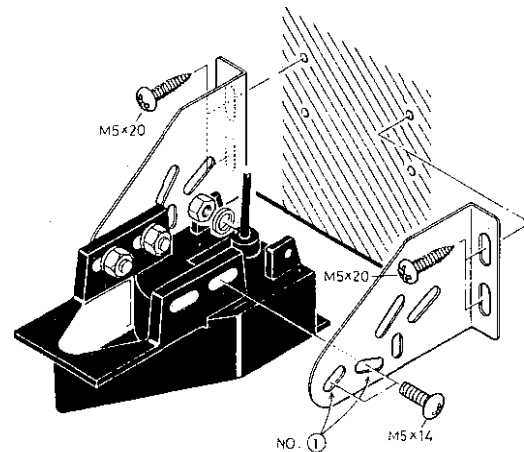

METHOD (2) ... projected from hull

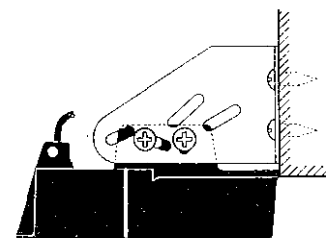
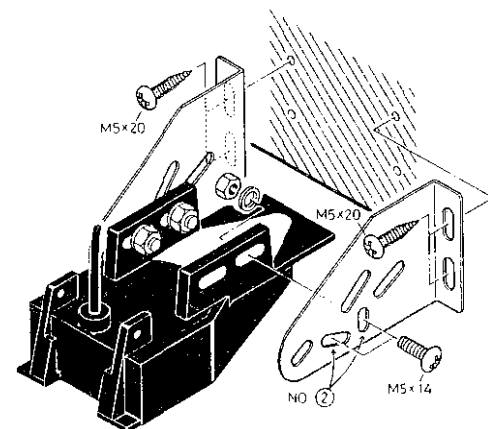

Installation

Through-Hull Mount

This type of mounting provides the best performance of all, since the transducer protrudes from the hull and the effect of air bubbles and turbulence near the hull skin is reduced. To determine the transducer location, keep in mind the general considerations described on page 30. Also, when the boat has a keel, the transducer should be at least 30 cm (1 foot) away from it. Typical through-hull mountings are illustrated below.

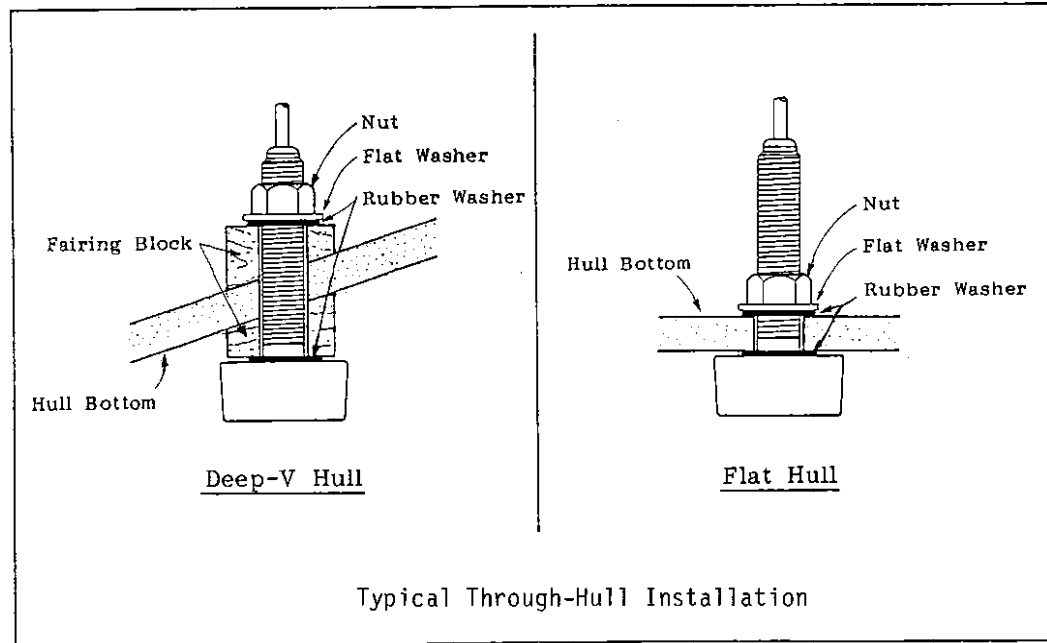

Through-hull mounting is accomplished as follows.

1. With the boat hauled out of the water, mark the location selected for mounting the transducer on the bottom of the hull.
2. If the hull is not level within 15 degrees in any direction, fairing blocks made out of teak should be used between the transducer and hull, both inside and outside, to keep the transducer face parallel with the water line. Fabricate the fairing block as shown on page 35 and make the entire surface as smooth as possible to provide an undisturbed flow of water around the transducer. The fairing block should be smaller than the transducer itself to provide a channel to divert turbulent water around the sides of the transducer rather than over its face.
3. Drill a hole just large enough to pass the threaded stuffing tube of the transducer through the hull, making sure it is drilled vertically.
4. Apply a sufficient amount of high quality caulking compound to the top surface of the transducer, around the threads of the stuffing tube and inside the mounting hole (and fairing blocks if used) to ensure water-tight mounting.
5. Mount the transducer and fairing blocks and tighten the locking nuts. Be sure that the transducer is properly oriented and its working face is parallel to the waterline. Do not over-stress the stuffing tube and

locking nuts through excessive tightening, since the wood block will swell when the boat is placed in the water. It is suggested that the nut be tightened lightly at installation and retightened several days after the boat has been launched.

CAUTION

The tightening torque should not exceed 400kg-cm. Excessive stress will cause damage to the threads of the plastic stuffing tube.

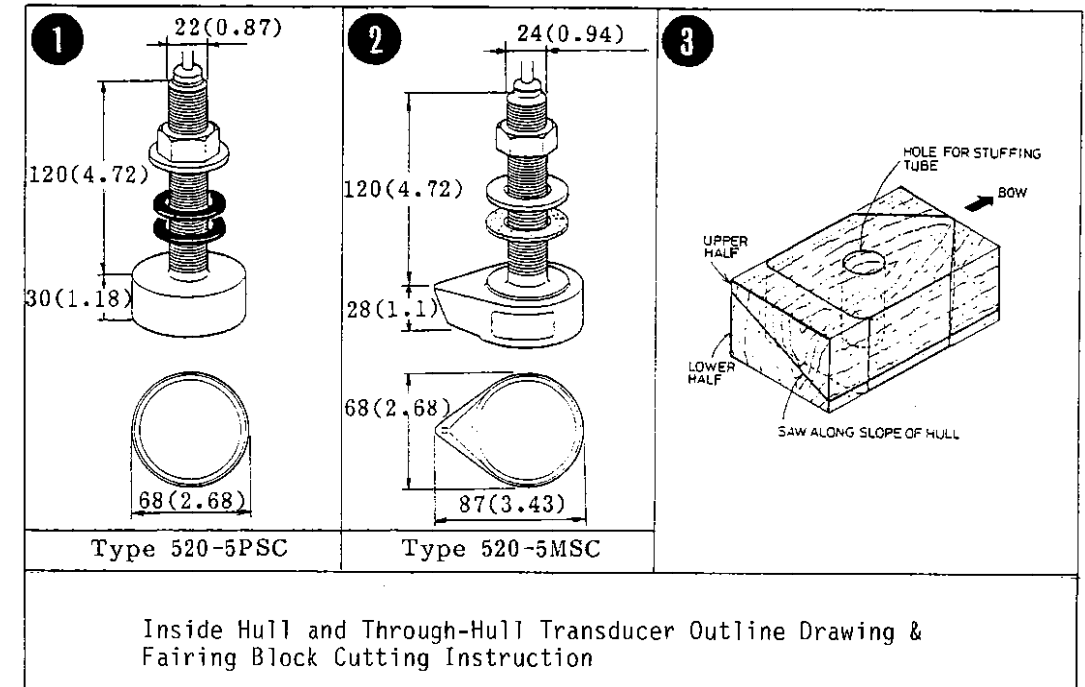

Transducer Preparation and Painting

Just prior to putting your boat into the water, the face of the transducer should be thoroughly wiped with a detergent liquid soap. This will lessen the time necessary for the transducer to establish good contact with the water. Eliminating this will lengthen the time required for complete "saturation" and will reduce the performance of the unit.

To maintain the sensitivity of the transducer, do not coat the face with heavy pigmented antifouling paints, i.e., cuprous oxide types. Use only a light, thin coat of a vinyl based antifouling paint, like International Paint's TRI-LUX No.67 or No.68.

FCV-522 CABLING DIAGRAM

TRANSDUCER + OPTIONAL SENSOR

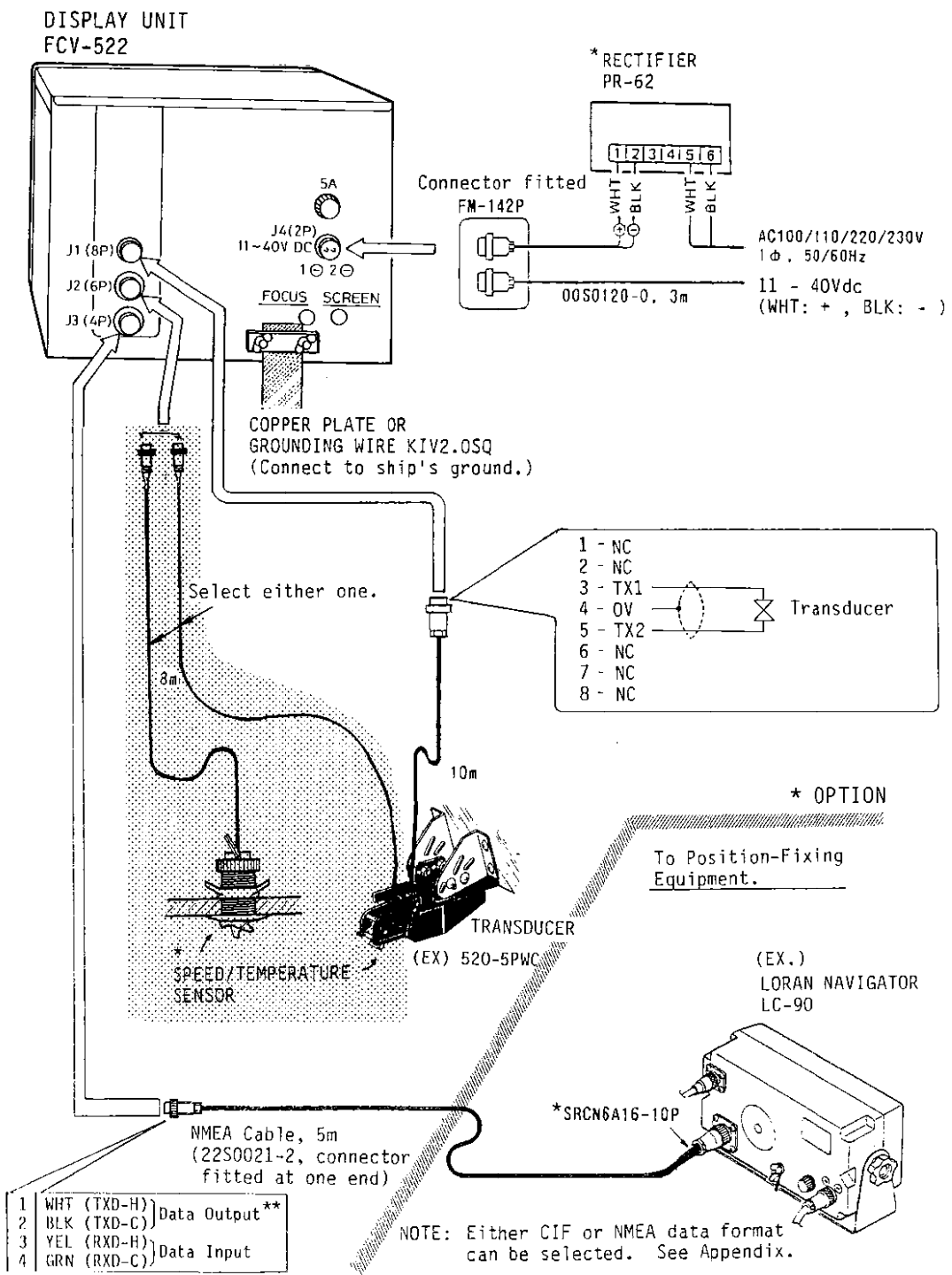

TRANSDUCER WITH SPEED/TEMPERATURE SENSOR

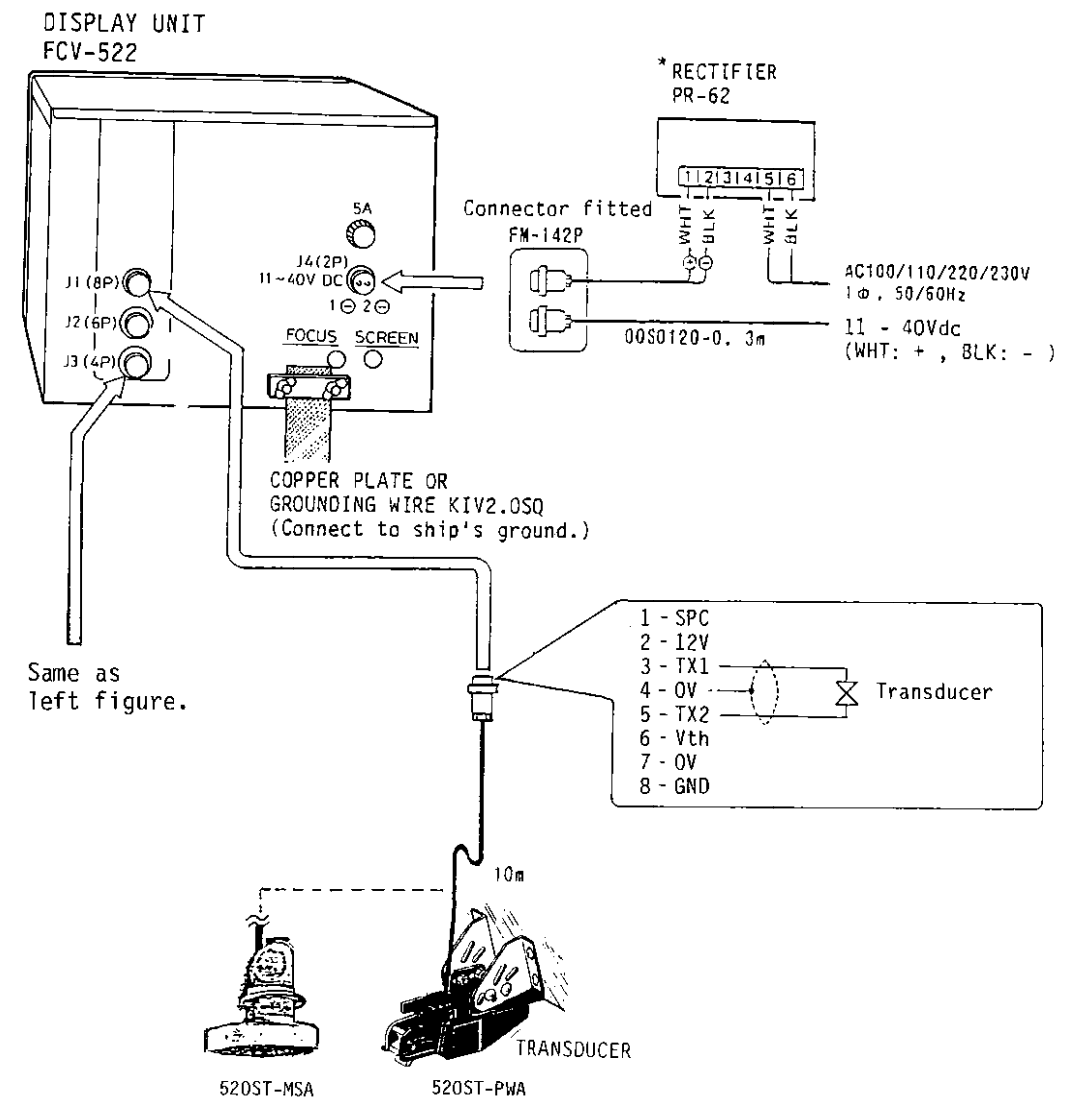

** Do not connect the line if the position-fixing
equipment need not echosounder data.

HOW TO CHANGE INTERNAL SETTINGS

Internal settings should be confirmed and/or changed according to user's preference, combined navigational equipment/optional sensor, etc.

* Procedures

- 1) Turn off the power pressing the PWR and OFF keys at the same time.
- 2) Remove the upper cover of the display unit by loosening the four fixing screws.
- 3) Change the settings of DIP switch S1 and S2 referring to the figure/table below.
- 4) The settings of S1 can be confirmed on the screen by the system diagnosis.

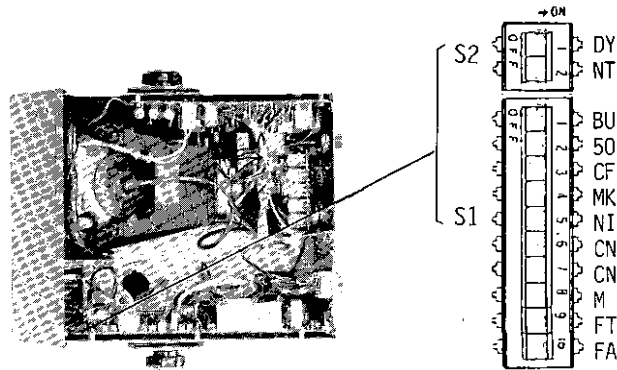

No.	Items	Setting				
		OFF	ON			
1	Memory Back up	OFF	ON			
2	Temperature Range	5°C	10°C			
3	Temperature Unit	°C	°F			
4	Speed Unit	MPH	KTS			
5	Temperature Sensor Select	NAV	SENS			
S1 6	Data Format	CIF	NMEA			
		CIF	NMEA			
8	Depth Unit	M	FT	FA	P/B	Hiro
9		#8 ON	OFF	OFF	ON	OFF
10		#9 OFF	ON	OFF	ON	OFF
		#10 OFF	OFF	ON	OFF	OFF

No.	Item	Setting					
S2 1	Brilliance of Background	OFF	Dark	OFF	Mid.	ON	Bright
		OFF		ON		OFF	

NOTE: 1) Remove the back-up battery when forwarding the 02P6067 (MIN) board for repair.

SPECIFICATIONS OF FCV-522 SOUNDER

1. Basic Range

Setting	1	2	3	4	5	6	7	8
Meters	5	10	20	40	80	150	200	300
Feet	15	30	60	120	250	500	750	1000
Fathoms	2.5	5	10	20	40	80	120	150
P/B	3	5	10	25	50	100	150	200

P: Passi B: Braza

Unit is selected with an internal DIP switch.

2. Shifted Range

	Maximum phased range	
Meters	300	Shifting step: 1 or 10m (ft,fa or p/b)
Feet	1000	
Fathoms	150	In case the depth is greater than 500ft, the shifting step is 10ft only.
P/B	200	

3. Zoom Range

Setting	1	2	3	4	5	6	7	8
Meters	4	4	5	10	20	25	50	50
Feet	10	10	20	20	50	100	120	200
Fathoms	2	4	4	5	10	20	20	25
P/B	2	4	4	5	10	20	25	50

P: Passi B: Braza

4. Bottom-Lock Range

Meters	Feet	Fathoms	P/B
2.5	10	1.25	2.5

5. Automatic Bottom Tracking

The automatic bottom tracking feature automatically phases the range so that the bottom is always displayed on the lower portion of the screen.

6. Display

8" rectangular color CRT. Echoes are displayed in 6 (for daytime use) or 8 (for nighttime use) colors depending on menu display setting.

7. Display Mode

[SNDR] Echo sounder Display

- "L" : Normal (Low Frequency)
- "H" : Normal (High Frequency)
- "LB" : Normal(2/3) + Bottom-Lock Expansion(1/3), (Low Frequency)
- "HB" : Normal(2/3) + Bottom-Lock Expansion(1/3), (High Frequency)
- "LH" : Normal (1/2, Low Frequency) + Normal (1/2, High Frequency)

[ZM] Zoom Display

"ZOOM": Normal (right 1/2) + Zoom (left 1/2)

[GR] Water Temperature Graph Display

"GR" : Normal (2/3) + Water Temperature Graph*(1/3)

[NAV] Navigation Data Display

Water depth, temperature*, ship's speed*, L/L data**, alarm/zoom range and calibration value of water/temperature are digitally displayed on the entire screen.

* ... Speed/temperature sensor is necessary to be connected.

** ... Nav equipment is necessary to be connected.

8. Picture Advance Speed

Setting	0	1	2	3	4
Scan Line/ Transmission	FREEZE	1/6	1/4	1/2	1/1

9. Pulselength and Repetition Rate

Range	Pulse Repetition (pulses/min)	Pulselength (ms)
0 - 20m	425	0.2
21 - 40m	425	0.3
41 - 60m	280	0.4
61 - 80m	280	0.6
81 - 100m	185	0.8
101 - 120m	185	1.0
121 - 140m	185	1.2
141 - 160m	185	1.5
161 - 180m	145	1.8
181 - 200m	145	2.1
201 - 250m	105	2.4
251 - 300m	105	2.8
301 - 320m	105	3.2
321 - 400m	65	3.2
401 - 640m	65	3.6

10. Transmission Frequency

50kHz and 200kHz (Single or alternative transmission)

11. Output Power

150W rms

12. Color Presentation

LEVEL	STRONGEST				NO SIGNAL			
	7	6	5	4	3	2	1	0
NIGHT	REDDISH BROWN	RED	ORANGE	YELLOW	GREEN	LIGHT BLUE	BLUE	DEEP BLUE
DAY	RED		ORANGE	YELLOW	GREEN	LIGHT BLUE		BLUE

13. Alarm

Fish and Bottom Alarms

Alarm sounds when echo or bottom reflection stronger than red and red-dish brown intensity comes into the alarm depth zone.

Water Temperature Alarm

Alarm sounds when water temperature above or below the preselected temperature is detected by an optional water temperature sensor.

14. Data Communications

The FCV-522 permits data communication with Navigational Equipment and Temperature Indicator which have I/O port for NMEA0183 or Furuno CIF format.

<u>Input</u>	1) Latitude, Longitude	<u>Output</u>	1) Depth
	2) Ship's Speed		2) Water Temperature
	3) Water Temperature		3) Ship's Speed(*)

*--- NMEA format only

15. Optional Navigation Devices

Loran Receivers LC-90, LC-900/900(M), Loran Plotters LP-1000, Video Plotters GD-1000/180, Satellite Navigators FSN-70, GPS Navigator GP-300 and Water Temperature Indicator T-1000

16. Power Supply

11-40 VDC universal, less than 45W

16. Environmental Condition

0 - 50°C

[COMPLETE SET]

No.	Name	Type	Code No.	Q'ty
1	Display Unit	CV-522	000-C14-474	1
2	Transducer	520-5PWC *1	000-115-414	1
		520-5PSC *2	000-115-415	
		520-5MSC *3	000-115-416	
		520ST-PWA *4	000-115-417	
		520ST-MSA *5	000-115-418	
3	Installation Materials	CP02-03400	000-024-791	1 set
4	Accessories	FP02-02200	000-024-948	1 set
5	Spare Parts	SP02-02300	000-024-732	1 set
6	Documents	Operator's Manual, Packing List		1 set

*1: Transom
 *2: Thru-hull, plastic
 *3: Thru-hull, metallic
 *4: Transom, w/speed temperature sensor
 *5: Thru-hull, metallic,
 w/speed temperature sensor

[OPTION]

No.	Name	Type	Code No.	Q'ty
1	Speed/Temperature Sensor	ST-01PTB *1	000-019-503	1
		ST-01PSB *2	000-019-504	
	Temperature Sensor	ST-01MSB *3	000-019-505	
	T-02MSB *4	000-040-044		
	T-02MTB *5	000-040-026		
	T-03MSB *6	000-040-027		
2	Suction Cup Mount	OP02-15	000-013-633	
3	ST Sensor Bracket	OP02-30	000-014-414	1
3	Kick-up Bracket	OP02-29	000-014-413	1
4	Loran Connection Kit	CP02-02320	001-358-230	1
5	Adhesive	OP02-31	000-013-634	1
6	Rectifier	PR-62, 100VAC	000-013-484	1
		" , 110VAC	000-013-485	
		" , 220VAC	000-013-486	
		" , 230VAC	000-013-487	

*1: for transom mount *4: metallic, for thru-hull mount
 *2: plastic, for thru-hull mount *5: for transom mount
 *3: metallic, for thru-hull mount *6: for thru-hull mount

[INSTALLATION MATERIALS]

No.	Name	Type	Code No.	Q'ty	Fig.
1	Power Cord Assy.	00S0120-0 *3m*	000-104-058	1	1
2	Grounding Wire	KIV 2.0SQ *2m*	000-554-516	1	2

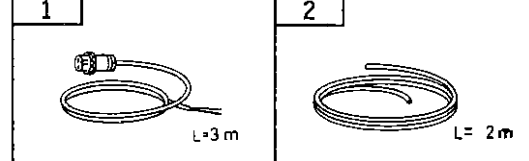

[ACCESSORIES]

No.	Name	Type	Code No.	Q'ty	Fig.
1	Bracket Assy.	FP02-01410	001-373-880	1	1
2	Filter Assy.			1	2
3	Liner	3.1x10x2.0 (C2801P)	000-864-817	1	3
4	Knob Bolt Assy.	FP02-00250	000-800-418	1	4
5	Viewing Hood	02-043-1301-2	204-313-012	1	5
6	Cover	02-074-1431-0	000-801-095	1	6

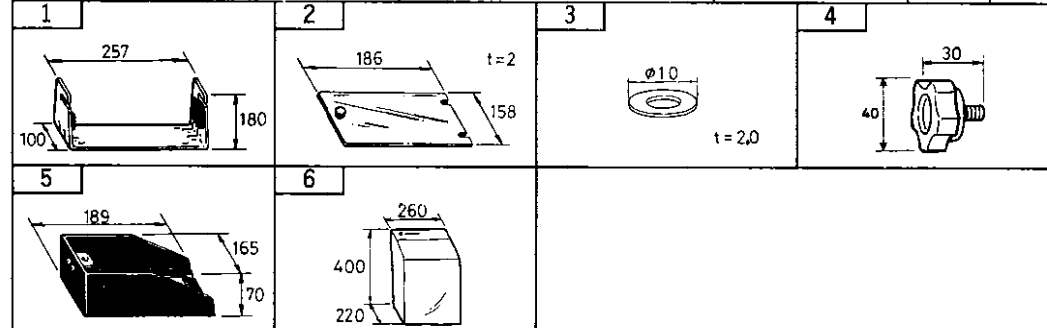

[SPARE PARTS]

No.	Name	Type	Code No.	Q'ty
1	Fuse	FGBO-A 5A AC125V	000-549-064	3

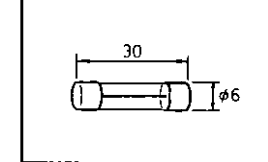

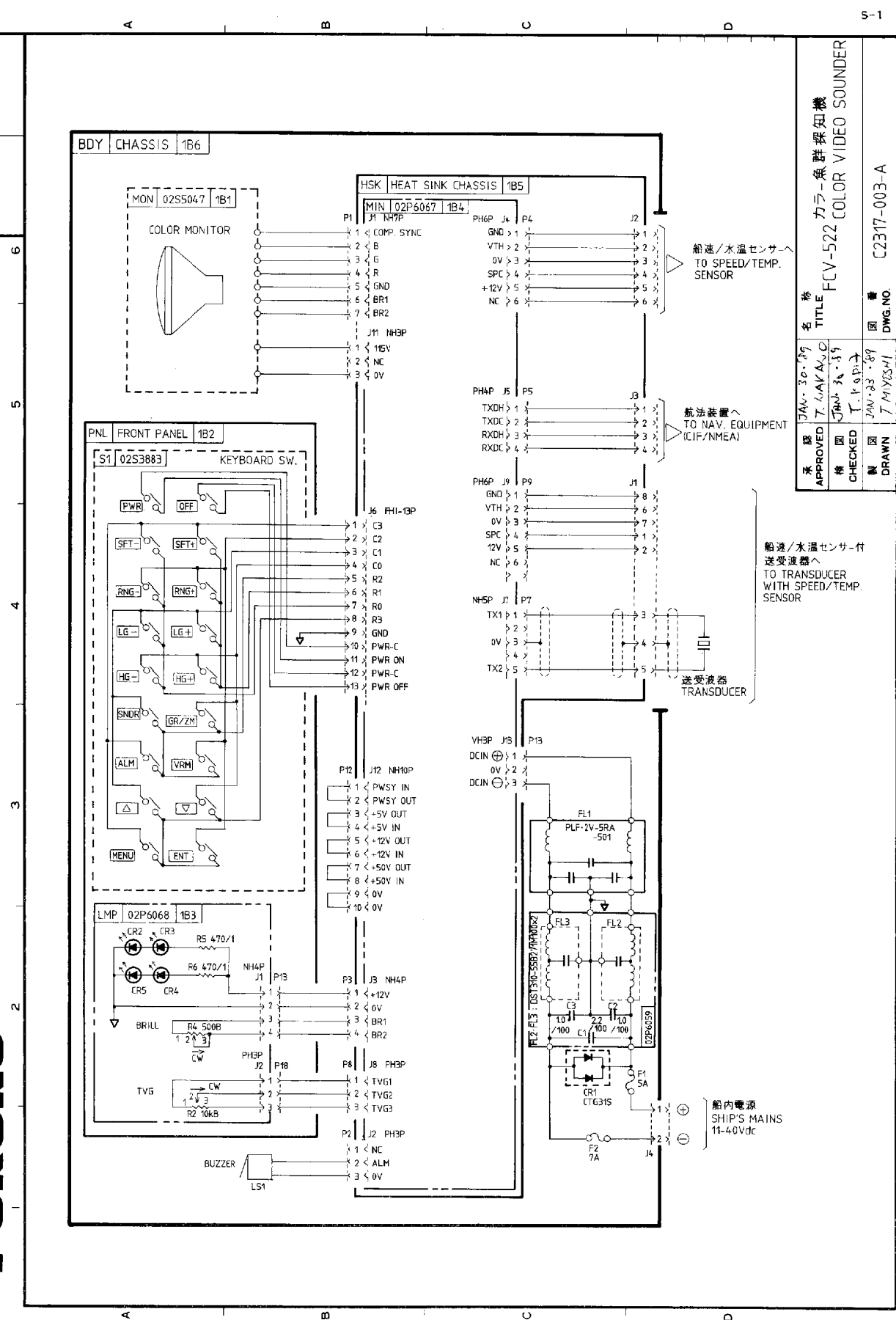

承認	JAN-30-89	名称	カラー-魚群探知機
校閲	T. KAKAJI	図番	C2317-003-A
チェック	T. KODAI	図名	FCV-522 COLOR VIDEO SOUNDER
製図	JAN-23-89	図番	C2317-003-A
描画	T. Miyoshi	図名	FCV-522 COLOR VIDEO SOUNDER

FURUNO ELECTRIC CO., LTD.

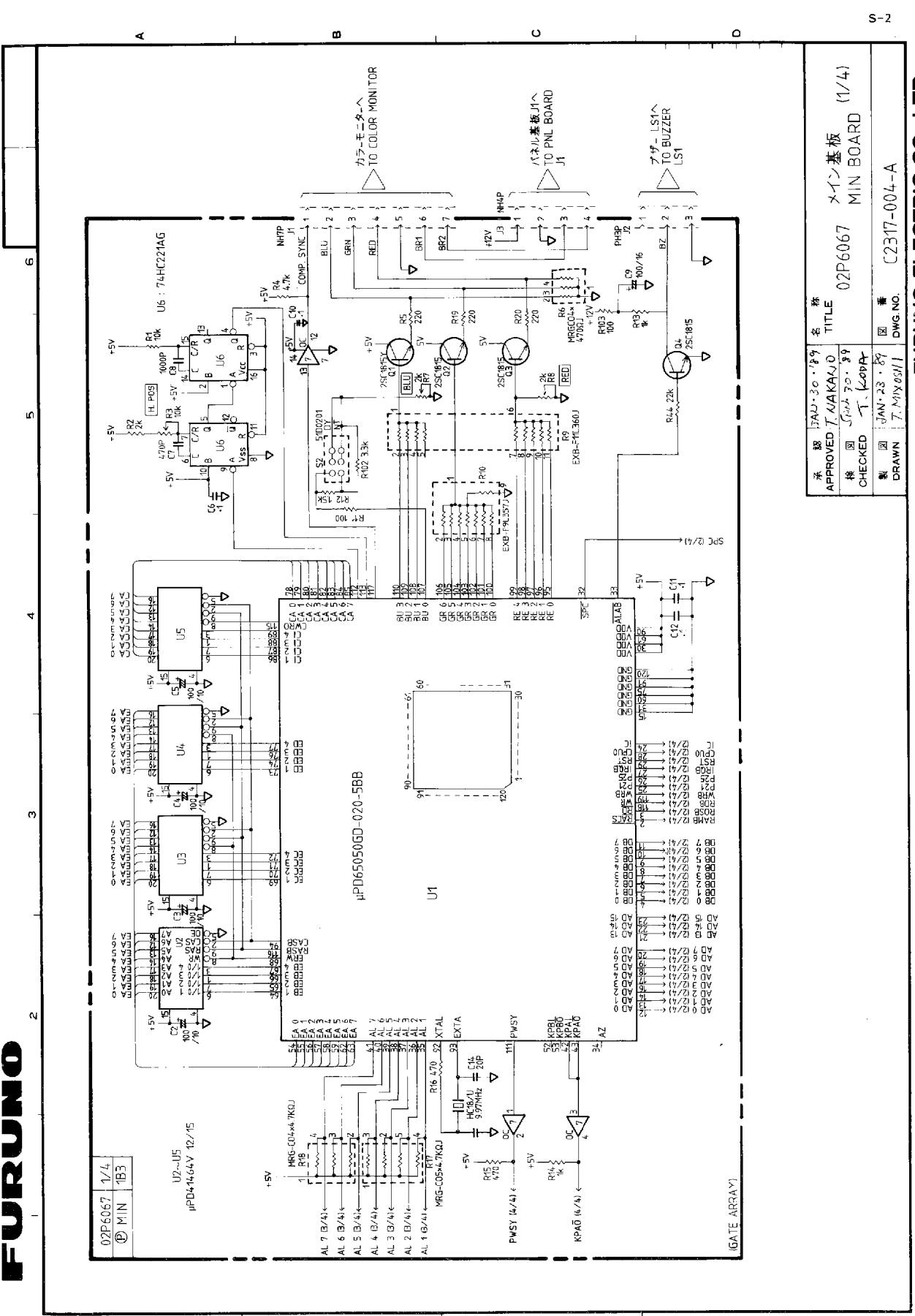

承認	JAN-30-89	名称	メイン基板
校閲	T. KAKAJI	図番	C2317-004-A
チェック	T. KODAI	図名	02P6067 MIN BOARD (1/4)
製図	JAN-23-89	図番	C2317-004-A
描画	T. Miyoshi	図名	02P6067 MIN BOARD (1/4)

FURUNO ELECTRIC CO., LTD.

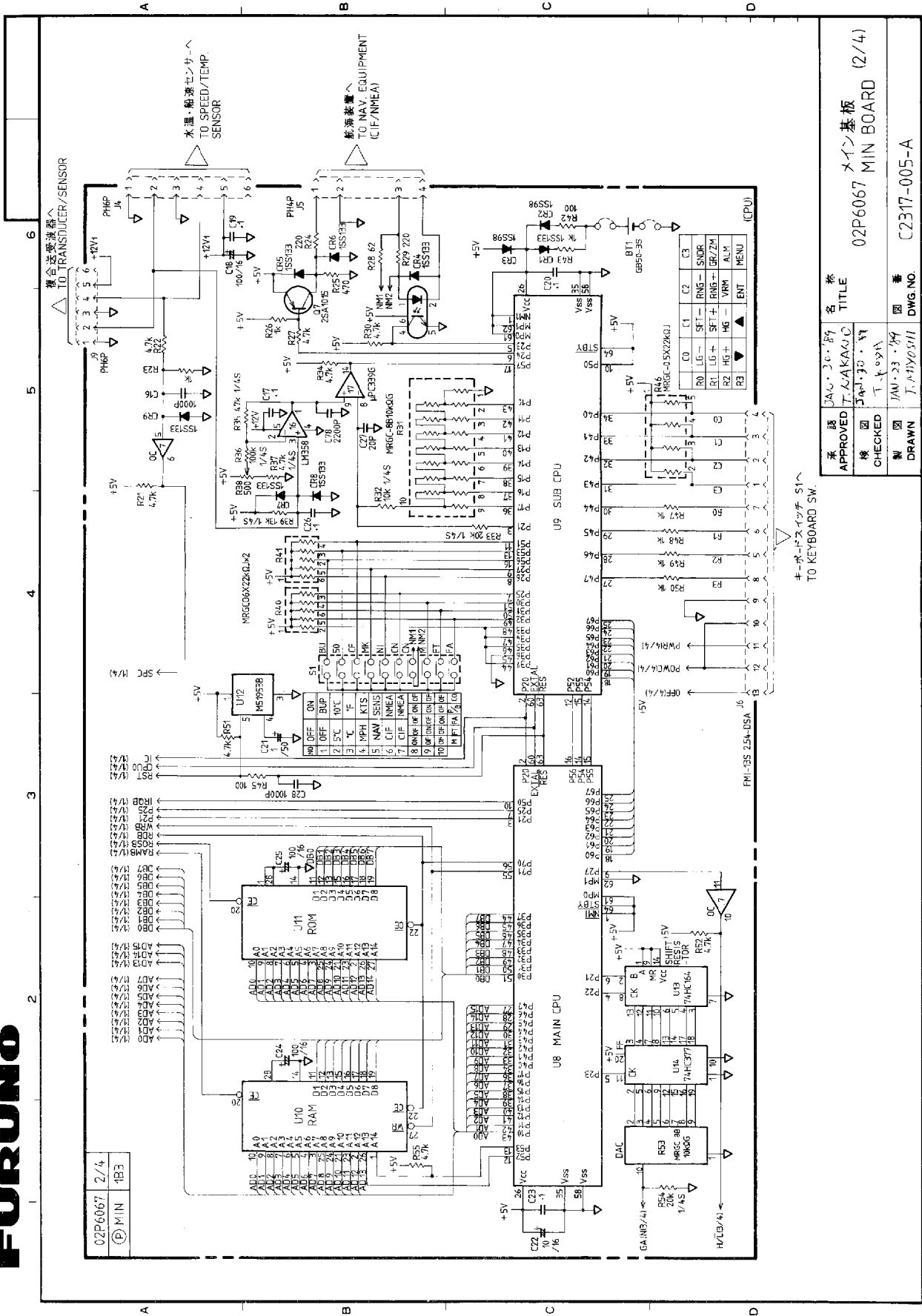

承認 APPROVED	検査 CHECKED	製図 DRAWN	名 称 TITLE
JAU・30・89	TAKAKAO	JAN・23・89	02P6067 メイン基板 (2/4)
検査 CHECKED	TAKAKAO	製図 DRAWN	図 番 DWG. NO.
JAN・23・89	TAKAKAO	JAN・23・89	C2317-005-A

FURUNO ELECTRIC CO., LTD.

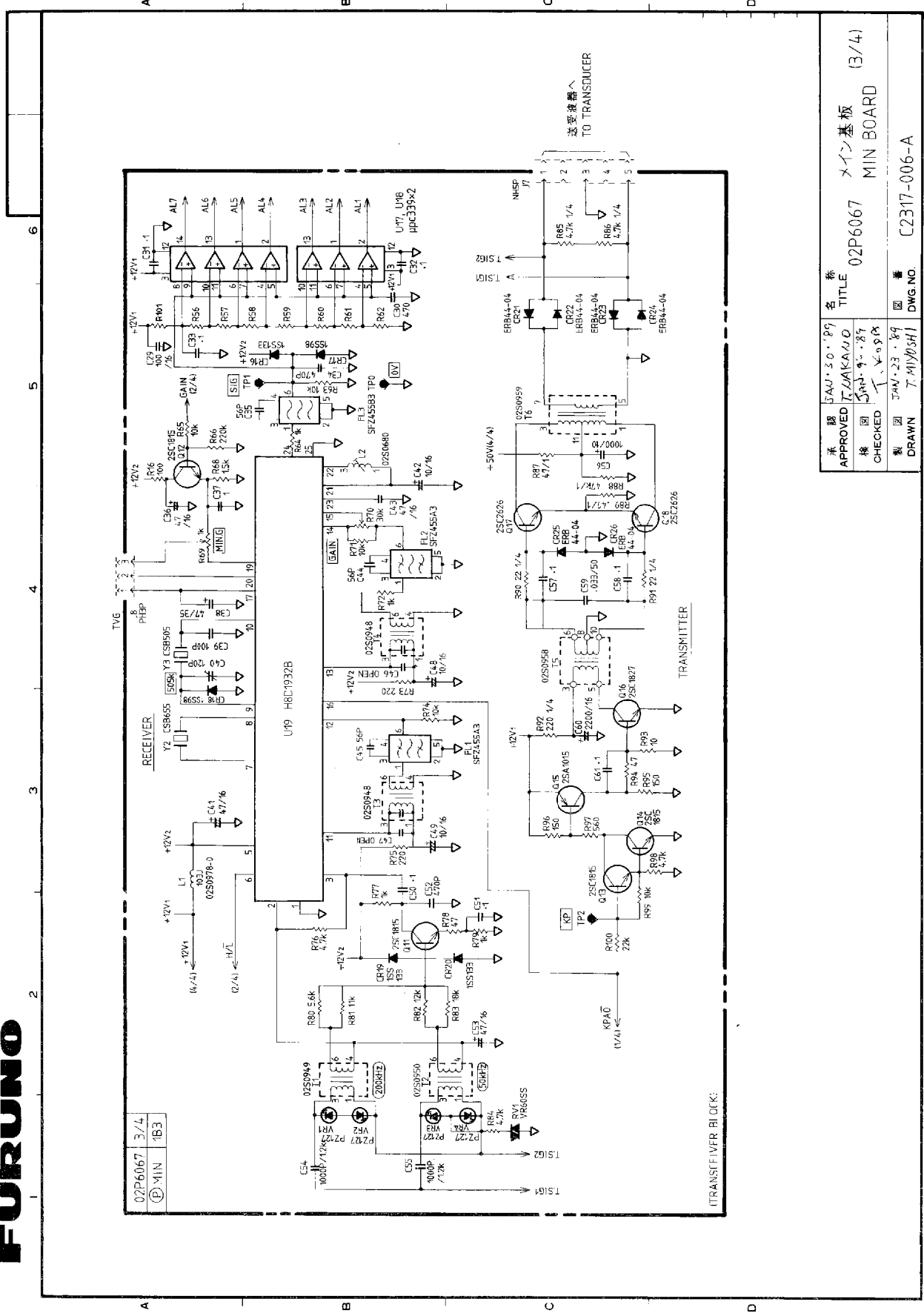

承認 APPROVED	検査 CHECKED	製図 DRAWN	名 称 TITLE
JAU・30・89	TAKAKAO	JAN・23・89	02P6067 メイン基板 (3/4)
検査 CHECKED	TAKAKAO	製図 DRAWN	図 番 DWG. NO.
JAN・23・89	TAKAKAO	JAN・23・89	C2317-006-A

FURUNO ELECTRIC CO., LTD.

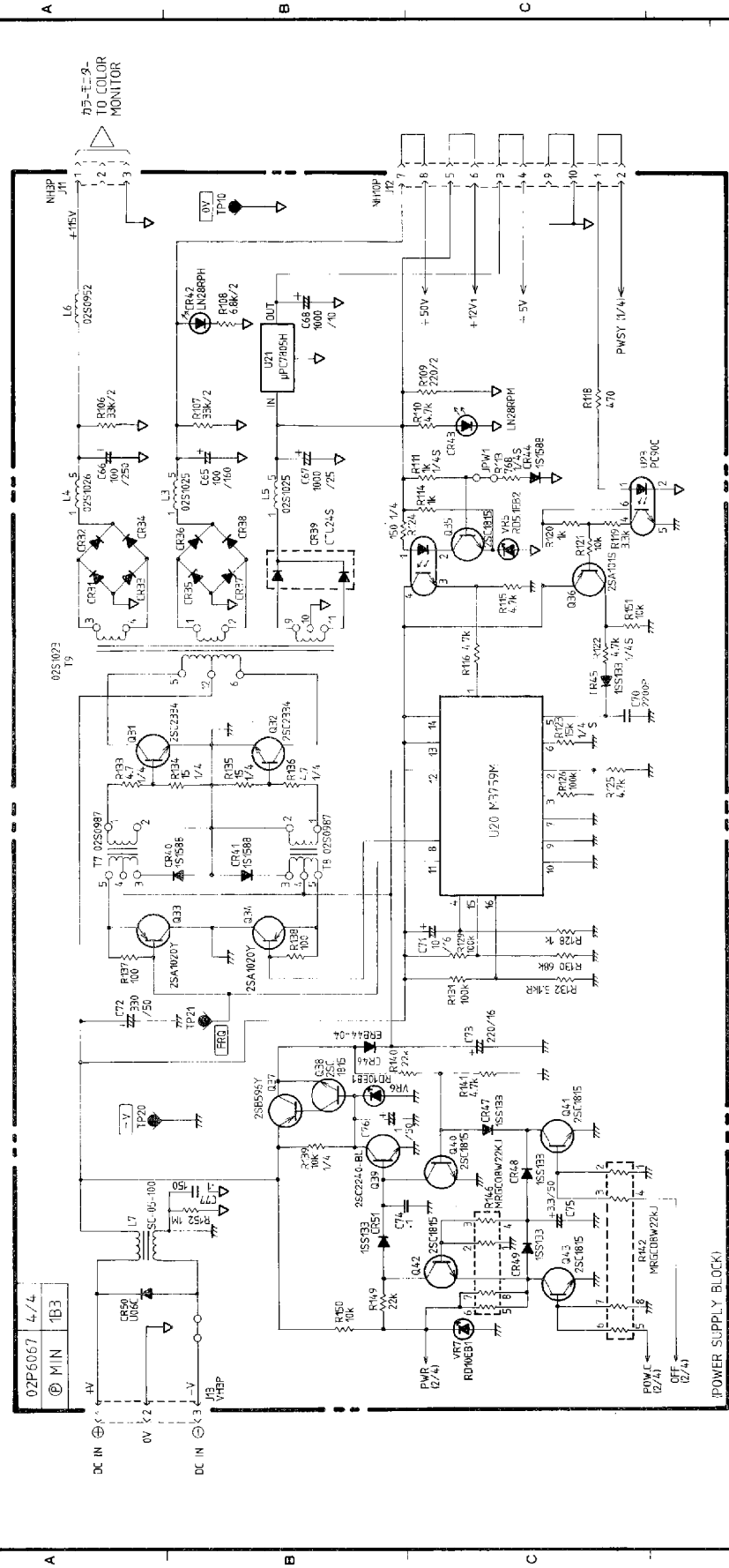

承認	JAN. 30. 89	名称	
APPROVED	T. AKAKI	TITLE	02P6067 メイン基板 (4/4)
検閲	JUN. 10. 89		
CHECKED	T. KODAI		
製図	JAN. 23. 89	図番	C2317-007-A
DRAWN	T. MIYASHI	DWG. NO.	

FURUNO ELECTRIC CO., LTD.

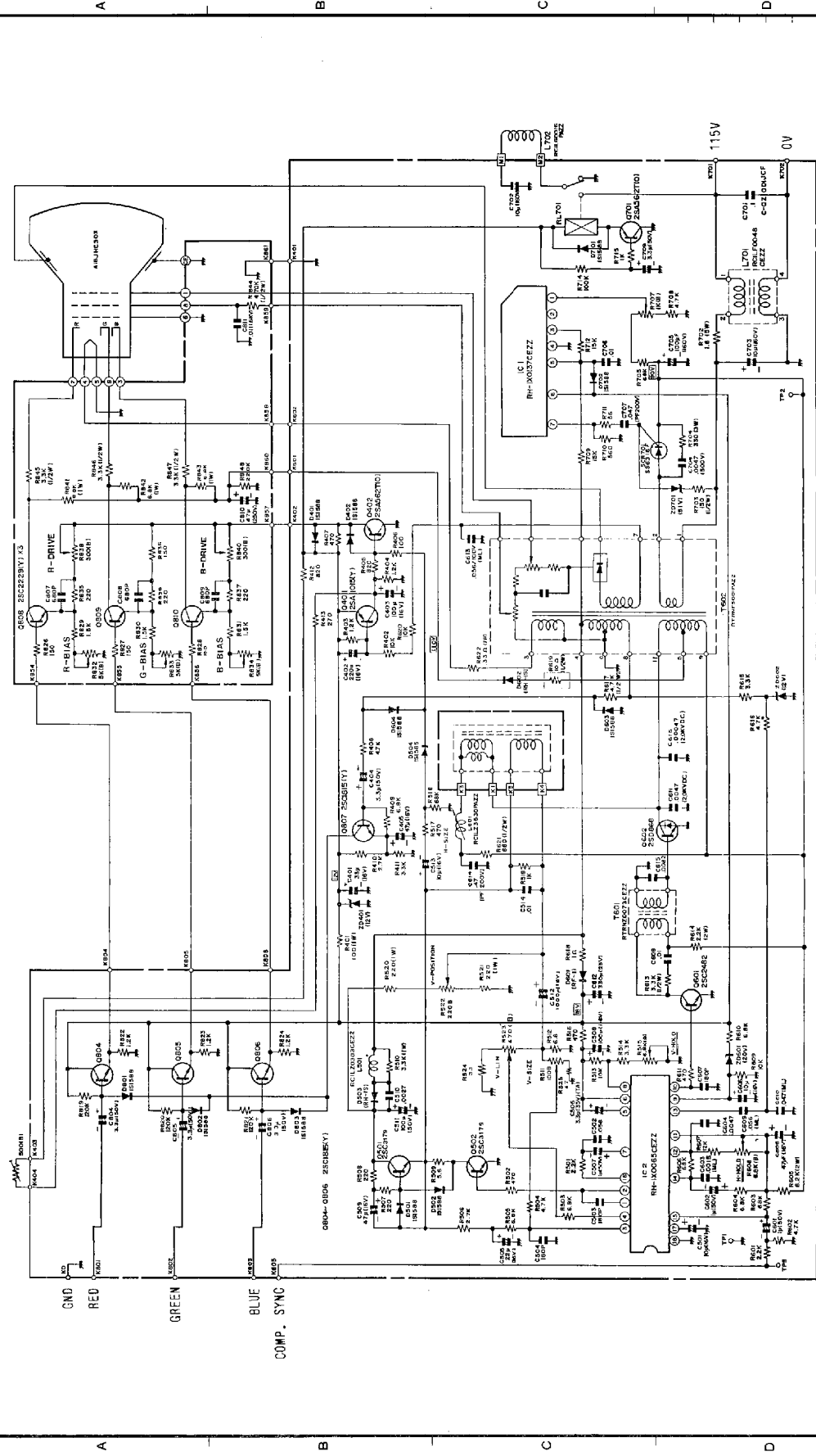

承認	JUN. 10. 89	名称	
APPROVED	T. AKAKI	TITLE	A1QA8DSP15 カラーモニター COLOR MONITOR
検閲	JUN. 10. 89		
CHECKED	T. KODAI		
製図	JAN. 10. 87	図番	C2308-013-B
DRAWN	T. MIYASHI	DWG. NO.	

FURUNO ELECTRIC CO., LTD.

INSTALLATION OF OPTIONAL DEVICES

Mounting Transom Type Transducer using Kick-up Bracket (0P02-29)

When the transducer is mounted extruded from the hull bottom as shown on page 32, Method (2), it is subject to damage or loss due to floating objects, such as a log.

To minimize such an accident it is recommended to install the transducer, using the optional Kick-up Bracket as shown below. When an impact by the floating object or extraordinary water pressure is added, the transducer will be kicked up and damage or loss will be avoided. It is also a good idea to flip the transducer up when the boat is hauled out of water/put on a trailer.

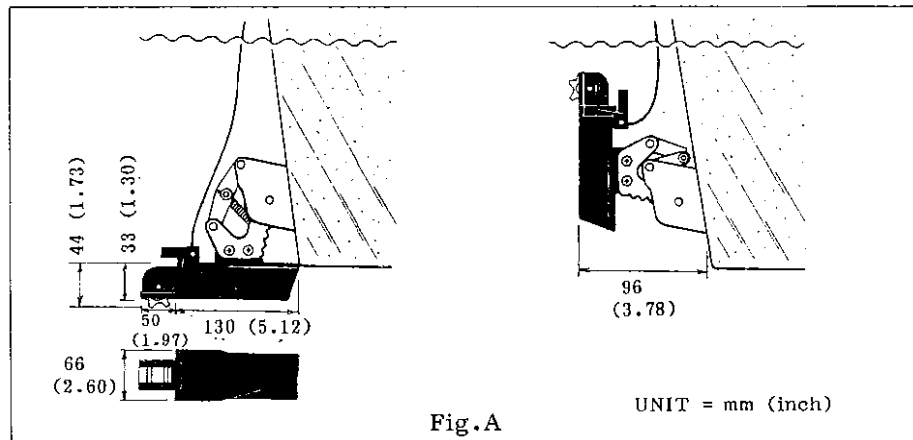

Fig.A

Mounting Transom Type Sensor (ST-01PTB)

(1) When the transom type transducer (520-5PWC) is mounted extruded from the hull bottom as shown on page 32, Method (2) or is mounted with the kick-up bracket, the sensor can be directly attached to it as shown below without using any installation material.

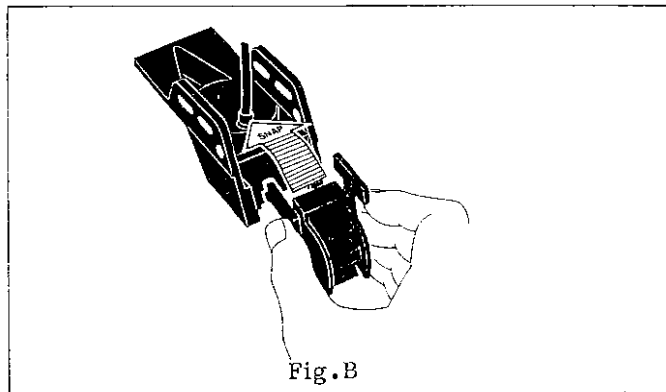

Fig.B

AP-1

(2) When the transom type transducer (520-5PWC) is mounted flush with the hull bottom as shown on page 32, Method (1), the sensor can not be attached to the transducer because it is mounted with the sensor snapping side directed to the transom. In such a case, the sensor must be installed separately, using the optional Sensor Bracket (0P02-30). See the right figure.

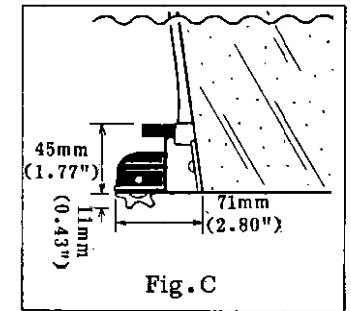

Fig.C

Hooking up Ship's Position Data from Position Fixing Equipment

Furuno Loran Receiver

To interface the Loran receiver with the video sounder, the Loran Connection Kit (Code No. 001-358-230) is optionally required. The contents of the kit are as follows.

1	NMEA Cable	22S0021-3	5 m	Connector fitted at one end.
2	Connector	SRCN6A16-10P	1 pc.	For loran side.
3	Rubber Bush	02-073-2001-0	1 pc.	

[Connection Example: LC-90]

This sounder can accept NMEA #0183 format data, and may be connected to either Port-1 (pin #1 and #2) or Port-2 (pin #5 and #6) of the LC-90. If you wish to connect an autopilot (NMEA #0180) to the LC-90, however, you should connect this sounder to Port-1, leaving Port-2 for the autopilot. Note that only Port-2 can output data of NMEA #0180 format.

According to the output port (Port-1 or Port-2) you selected, solder the yellow and green leads to the plug (Pin #1/2 or Pin #5/6) and connect the both units as illustrated below.

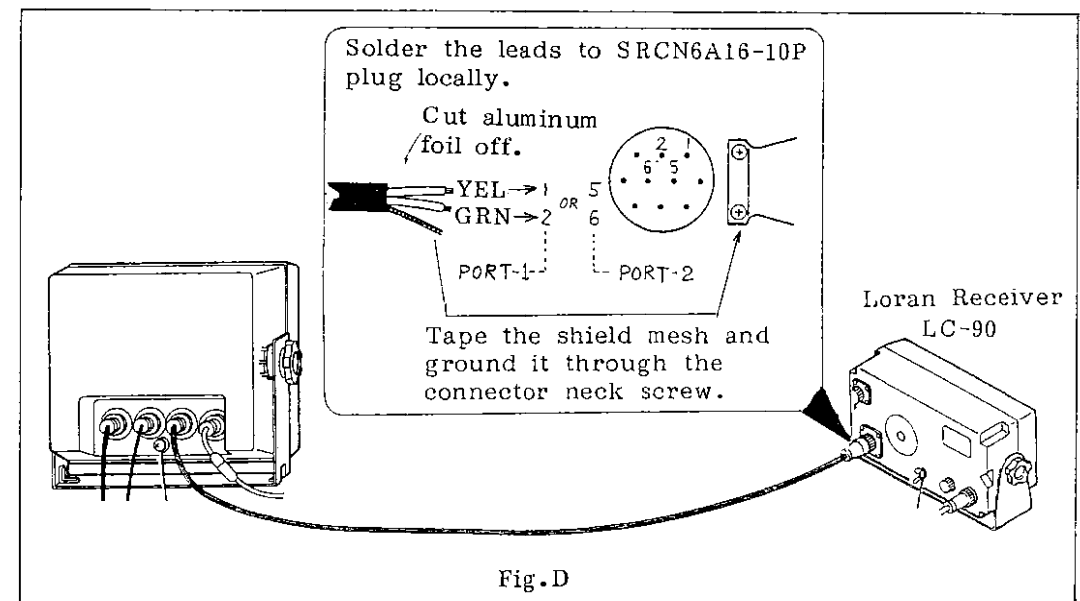

Fig.D

AP-2

After having connected the sounder to the LC-90, change the output format on the LC-90:

- (1) Press **#** and **3** keys in order to select Function 3, and the formats assigned to Port-1 and Port-2 will be presented as shown right.
- (2) Press **▼** key until the cursor moves down to the intended line.
- (3) Press **CLR** key.
- (4) Press **+/-** key several times until "183" is displayed at the right of the port number.
- (5) Press **ENT** key.

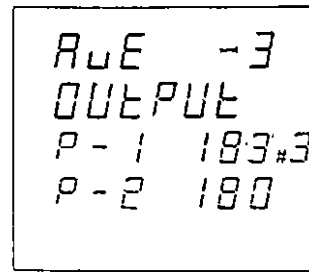

Fig. E

Other Make Position Fixing Equipment with NMEA #0183 Format Output

The Loran Connection Kit is also optionally required. But procure a plug for the accompany position fixing equipment locally. The wiring is similar to the said diagram: connect the yellow and green leads to the SIGNAL and RETURN lines respectively. And ground the shield of the cable with the CHASSIS of the equipment.

MOUNTING TEMPERATURE SENSOR

Transom Type (T-02MTB)

Mounting Location and Method

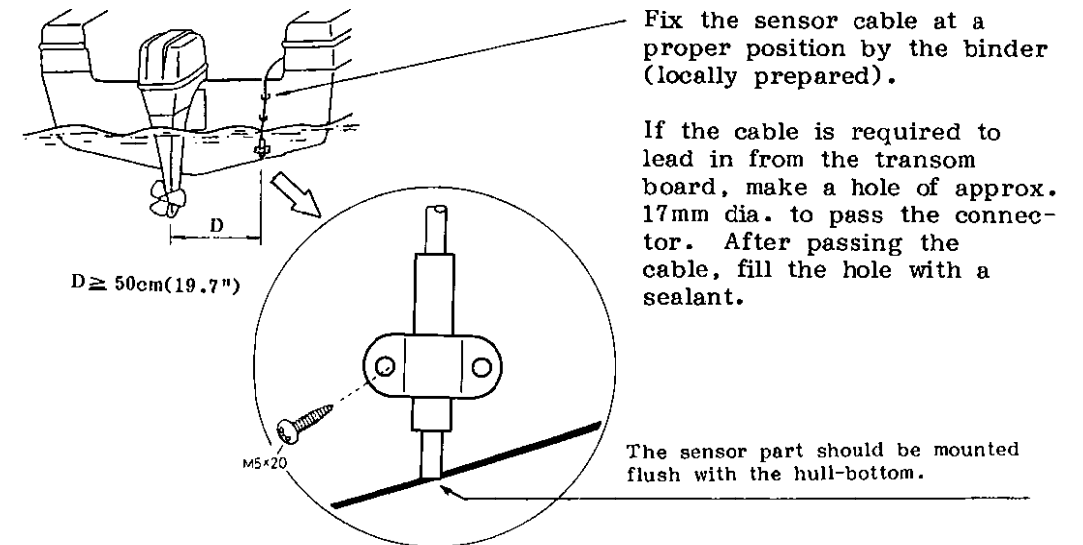

Fix the sensor cable at a proper position by the binder (locally prepared).

If the cable is required to lead in from the transom board, make a hole of approx. 17mm dia. to pass the connector. After passing the cable, fill the hole with a sealant.

The sensor part should be mounted flush with the hull-bottom.

Thru-hull Type (T-02MSB, T-03MSB)

Mounting Location

1. Select a mid-boat, flat position. The sensor does not have to be installed perfectly perpendicular. The sensor must not be damaged in dry-docking operation.
2. Select a place apart from the equipment generating heat.
3. Select a place in the forward direction viewing from the drain hole for cooling water.
4. Select a place free from vibration.

Mounting Procedure

T-02MSB	T-03MSB
<ol style="list-style-type: none"> 1) Dry-dock the boat. 2) Make a hole of approx. 21mm (0.8") dia. on the hull bottom. 3) Run the sensor cable through the hole. 4) Pass the cable through the rubber packing, the washer and the lock nut as shown below. 5) Apply high-grade sealant to the sensor flange as shown below. 6) Fix the sensor by turning the lock nut. Do not tighten the nut excessively. (600kg-cm max.) 7) After the launching, check for water leakage around the sensor. 	<ol style="list-style-type: none"> 1) Dry-dock the boat. 2) Make a hole of approx. 25mm (1") dia. on the hull bottom. 3) Apply high-grade sealant to the holder guide flange and pass the holder guide through the hole. 4) Fix the holder guide to the hull bottom using the rubber packing, the washer and the lock nut. Do not tighten the nut excessively. (600kg-cm max.) 5) Insert the sensor holder to the holder guide and tighten by the nut. 6) After the launching, check for water leakage around the sensor.
<p style="text-align: center;">21mm(0.8")</p> <p style="text-align: center;">Rubber Packing Washer Lock Nut</p> <p style="text-align: center;">Apply sealant.</p>	<p style="text-align: center;">Sensor Holder</p> <p style="text-align: center;">Lock Nut</p> <p style="text-align: center;">Lock Nut Washer Rubber Packing</p> <p style="text-align: center;">ϕ25mm</p> <p style="text-align: center;">Apply sealant.</p> <p style="text-align: center;">Holder Guide</p> <p>Note: 1) For the boat of more than 25mm hull plate, this sensor is impossible to install.</p> <p>2) When the sensor seems to be deteriorated, the check, cleaning or replacement can be carried out without dry-dock.</p>

Free Manuals Download Website

<http://myh66.com>

<http://usermanuals.us>

<http://www.somanuals.com>

<http://www.4manuals.cc>

<http://www.manual-lib.com>

<http://www.404manual.com>

<http://www.luxmanual.com>

<http://aubethermostatmanual.com>

Golf course search by state

<http://golfingnear.com>

Email search by domain

<http://emailbydomain.com>

Auto manuals search

<http://auto.somanuals.com>

TV manuals search

<http://tv.somanuals.com>