

# VG 231 CA

<b>FOR YOUR SAFETY</b>	Page 2
<b>Warnings</b>	Page 3
<b>Preface</b>	Page 4
<b>1. Important notes</b>	Page 5-6
1.1 For your safety	Page 5
1.2 Operating for the first time	Page 5
1.3 About use	Page 6
<b>2. Structure and operating principle</b>	Page 7-8
2.1 Structure	Page 7
2.2 Special accessories	Page 7
2.3 Operating principle	Page 8
<b>3. Operation</b>	Page 9
<b>4. Cleaning and care</b>	Page 10
<b>5. Maintenance</b>	Page 11
5.1 General	Page 11
5.2 Remediying slight malfunctions yourself	Page 11
<b>6. Technical data / Table</b>	Page 12
<b>7. Practical tips</b>	Page 13-14
7.1 Accessories	Page 13
7.2 Cooking in the wok	Page 13
7.3 Recipes	Page 14
<b>8. Assembly instructions</b>	Page 15-20
8.1 Important notes	Page 15
8.2 Gas connection / electrical connection	Page 16
8.3 Nozzle replacement	Page 17-19
8.4 Installing the appliance	Page 20

## FOR YOUR SAFETY

---

**WARNING: If the information in this manual is not followed exactly, a fire or explosion may result causing property damage, personal injury or death.**

**Do not store or use gasoline or other flammable vapors and liquids in the vicinity of this or any other appliance.**

### **WHAT TO DO IF YOU SMELL GAS:**

- **Do not try to light any appliance.**
- **Do not touch any electrical switch; do not use any phone in your building.**
- **Immediately call your gas supplier from a neighbor's phone. Follow the gas supplier's instructions.**
- **If you cannot reach your gas supplier, call the fire department.**

**Installation and service must be performed by a qualified installer, service agency or the gas supplier.**

## Warnings

---

1. Do not allow the flame to extend beyond the edge of the cooking utensil. This instruction is based on safety considerations.
2. Do not forget that the unit becomes hot when in use. Common sense is important. Just because the flame is out, it does not mean parts still cannot be hot.
3. This appliance shall not be used for space heating. This instruction is based on safety considerations.
4. Be sure to disconnect the electrical supply before disassembly of the appliance.
5. Keep the appliance area clear and free from combustible materials, gasoline and other flammable vapors and liquids.
6. Do not obstruct the flow of combustion and ventilation air.
7. Cabinets installed above the gas cooktop must have a minimum distance of 600 mm (24").
8. The gas pressure regulator supplied with the appliance must be installed in line with the gas pipe.
9. The appliance and its individual shutoff valve must be disconnected from the gas supply piping system during any pressure testing of the system at test pressures in excess of 3,5 kPa (1/2 psig). The appliance must be isolated from the gas supply piping system by closing its individual manual shutoff valve during any pressure testing of the gas supply piping system at test pressures equal to or less than 3,5 kPa (1/2 psig).
10. **Important:**  
When using a very large pot, leave a gap of at least 50 mm (2") to avoid damaging any parts in counter top wood, plastic or other non-heat-resistant materials. Never leave oil or hot fat unattended.

**Note:**

To avoid jeopardising the electrical safety of the appliance, it is forbidden to use high-pressure or steam jet cleaning devices.

**Note:**

The name plate is attached to the bottom of the unit and to the inside of the housing.

**Only for installation in USA:**

This installation must conform to local codes or, in absence of local codes, with the National Fuel Gas Code, ANSI Z 223.1-1988.

The installer must leave these instructions with the appliance, and the consumer should retain them for future reference. If an external electrical source is utilized, the appliance must be electrically grounded in accordance with local codes, with the National Electrical Code ANSI/NFPA 70-1993.

**Only for installation in Canada:**

This installation must conform local codes or, in the absence of local codes, with the current CAN/CGA-B 149 Installation Code. The installer must leave these Instructions with the appliance and the Consumer should retain them for future reference.

This appliance when installed, must be electrically grounded in accordance with local codes or, in the absence of local codes, with the current CSA Standard C 22.1-Canadian Electrical Code, Part I.

For mobile Housing and Recreational Vehicle installation must conform with the following:

CAN/CSA Z240 MH

CAN/CSA Z240 RV

Installation Requirement For Gas Burning Appliances And Equipment In Mobile Homes CSA Standard C 22:1 - Canadian Electrical Code Part 1 and /or local Codes.

## Preface

**Cooking with your new gas cooker will be even more fun than before.**

The appliance offers you the following **advantages:**

- Regulation from hot to cold in seconds.
- High safety standard thanks to thermal protection elements for all burners.
- Thanks to the novel installation method implemented, installation is child's play!

To ensure that you will be able to use this appliance in all its diversity, read through the operating and assembly instructions conscientiously **before operating** it for the first time. The instructions contain important notes on use, installation and maintenance of the appliance.

You will find notes on page 5 that you ought to observe **before operating the appliance for the first time.**

The chapters entitled **"Structure and operating principle"** and **"Operation"** tell you all the things your cooker is capable of doing and how to operate the appliance.

The chapter entitled **"Cleaning and care"** will make sure that your appliance will stay operable and beautiful for a long time.

**And now we wish you lots of fun cooking.**



Fig. 1

# 1. Important notes

---

## 1.1 For your safety

You must not operate the appliance if it is damaged.

When connecting electrical appliances in the proximity of the appliance, make sure that connecting leads do not come into contact with hot cooking surfaces!

As the user, you yourself are responsible for maintenance and proper use in the household.

Only ever operate the appliance under supervision. Make sure that the burner parts are correctly fitted.

The appliance must only be operated with a wok, a pot or a pan on a ring.

**Note:**

If you have fitted the appliance cover VD 201-010 (special accessory) on the appliance, it must not be closed until the appliance has cooled down completely. Do not operate the appliance with the cover closed! Heat development may damage the appliance and the cover. Do not use the appliance cover as a surface for placing objects or for keeping things warm.

**Note:**

The appliance must not be combined with hob ventilators (VL 041/051).

**Important:** the appliance heats up during operation. Keep children away

Do not clean the appliance with a steam cleaning apparatus or with water pressure – **risk of short-circuits!**

Isolate the appliance from the mains during every maintenance operation. To do this, remove the mains plug or actuate the corresponding fuse. Close the gas supply.

Repairs must be carried out by authorised specialists, thus ensuring electrical safety. No warranty claims can be lodged for any damage resulting from failure to observe these instructions.

Observe **caution** with oils and fats. They may overheat and burn easily. Foodstuffs that are prepared in fat and oil (e.g. French fries) must only be prepared under constant supervision!

**Technical modifications reserved.**

## 1.2 Operating for the first time

Before operating the appliance for the first time, please pay attention to the following notes:

The appliance must only be connected by an authorised specialist.

Read through these instructions attentively before operating the appliance for the first time.

**Note:**

The rating plate for this appliance is included on a separate sheet. Keep the rating plate in a safe place along with your operating and assembly instructions.

Remove the packaging from the appliance and dispose of it properly.

Keep packaging elements away from children.

Thoroughly clean the appliance and accessories before using them for the first time. This will eliminate any "newness" smells and soiling (see chapter entitled "Cleaning and care").

---

### 1.3 About use

The appliance is intended solely for use in the household and must not be put to any other uses.

Use the appliance to prepare meals only. It must not be used to heat up the room in which it is installed.

Use of a gas cooker generates **heat and humidity** in the room where it is installed. This is why attention must be paid to good kitchen ventilation.

**Ventilation openings** must be kept unobstructed. Prolonged use of the appliance may call for additional ventilation such as opening a window or a door, or stronger air extraction by an extractor hood.

**To guarantee good combustion, the room in which the appliance is installed must have a minimum volume of 10 m<sup>3</sup> and must possess a door that opens outdoors or a window that can be opened.**

**Do not operate** the cooking position without a pot or a pan or a wok placed on it. **Do not heat up any empty pots or pans**; this may result in a build-up of heat. Use pots and pans with thicker bottoms because heat distribution is particularly improved in the low setting. The better the size of pots and pans is adapted to the burner size, the better the heat of the gas flame will be exploited and the more costs will be saved.

It is not permitted to use grilling stones because the resulting build-up of heat may damage the appliance.

Switch the burners to the low setting whenever you remove pots or pans briefly, thus saving gas and reducing pollution.

Whenever the gas hob is fitted under a vapour extractor hood, always cover the rings with pots or pans. Otherwise, parts of the vapour extractor hood may become damaged by the extreme heat development or grease residues in the filter may ignite. Ensure an adequate supply of air when using a vapour extractor operating in the exhaust air mode.

**Note:** the appliance must not be combined with hob ventilators (VL 041/051).

After igniting, keep the control knob pressed for around **5-8 seconds** more. The thermal sensor must be heated for 5-8 seconds before the knob can be released.

**In the event of a power failure**, you can also ignite the unit with matches or any other ignition aid. The thermal protection facility that prevent gas from flowing out in the open position functions without restriction.

Pots with a diameter of less than **100 mm (4")** or more than **320 mm (12 1/2")** should not be used. When using larger pots, pay attention to keeping to a minimum distance of **100 mm (4")** between the cooking vessel and combustible surroundings. A minimum distance of **15 mm (19/32")** must be observed between the control knob and the pot or pan.

**In the event of malfunctions**, contact your specialist dealer or your responsible Gaggenau after-sales service.

**Tip:** when buying pots, pay attention to the fact that the manufacturer frequently specifies the top pot diameter, which is generally larger than the diameter of the base.

Observe the manufacturer's specification! Use cooking utensils that the manufacturer states as being "suitable for gas".

## 2. Structure and operating principle

### 2.1 Structure

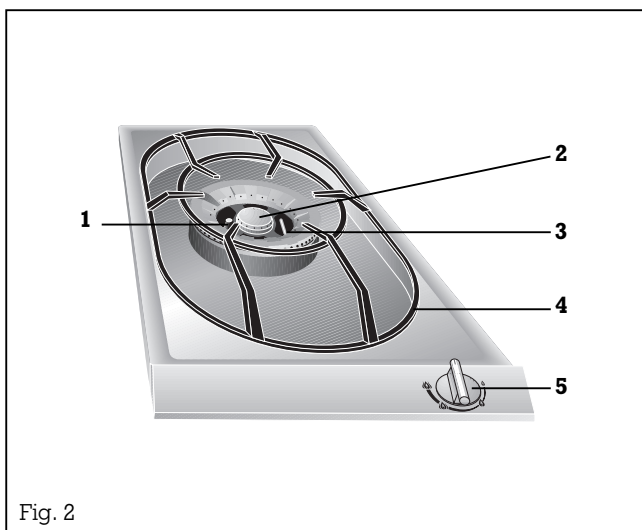

- 1 Spark plug for automatic ignition
- 2 Wok burner 3 000 - 17 000 BTU (0.25 - 5 kW)
- 3 Thermal fuse for flame monitor
- 4 Pot support
- 5 Control knob for the cooking position

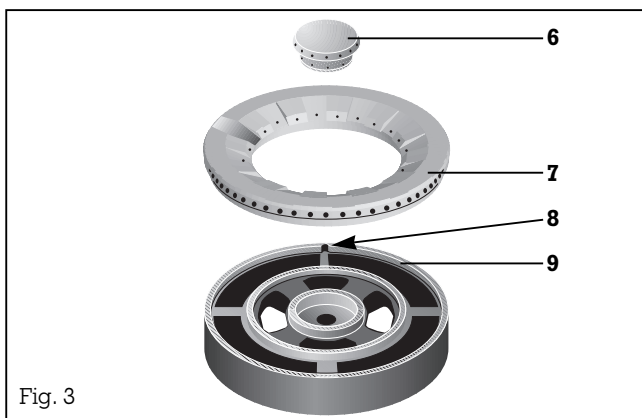

- 6 Burner cover
- 7 Burner ring
- 8 Burner head recess
- 9 Burner head

### 2.2 Special accessories

- You can order the following special accessories:
- **VV 200-000**: connecting trim
  - **VD 201-010**: appliance cover

## 2.3 Operating principle

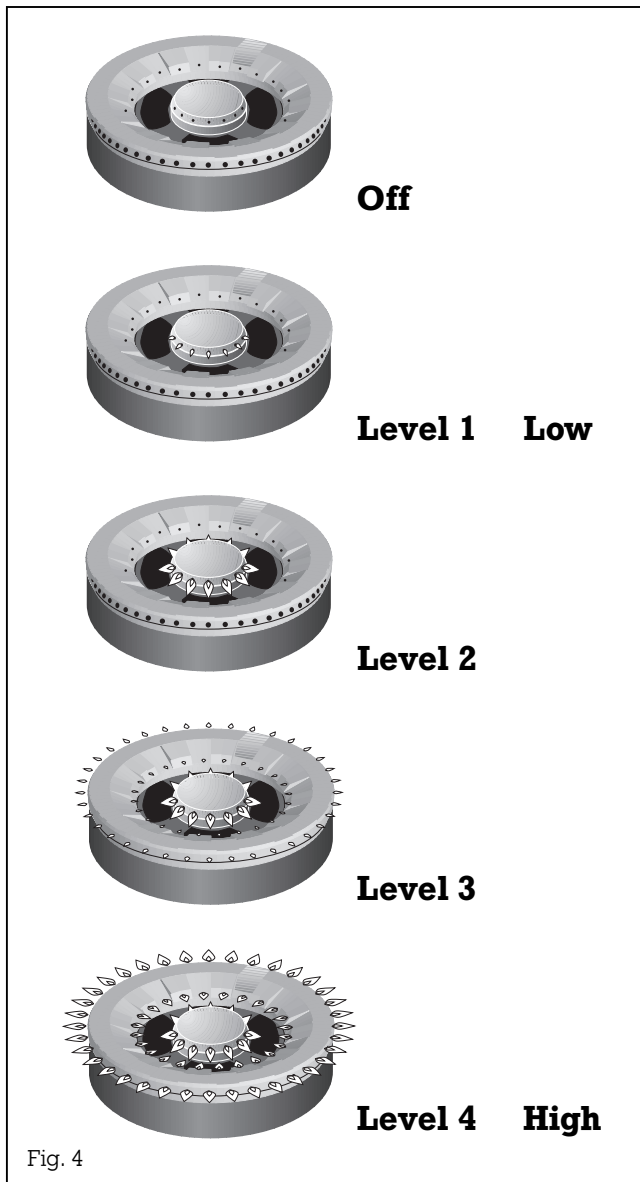

The appliance features one-hand operation. That is to say, the ignition is activated when the control knob is pressed briefly.

After igniting, keep the control knob pressed for around 5-8 seconds more because the heat sensor that opens the gas channel has to warm up first.

The burner has a **thermal protection device** that prevents unburned gas from escaping in the open position.

The **total rated thermal load** amounts to:  
17 000 BTU (5.0 kW) referred to  $H_S^*$  (gross calorific value)

15 300 BTU (4.5 kW) referred to  $H_i$  (calorific value)  
The specified rated load is defined by installation of the fixed nozzles.

The gas hob is converted to a **different gas type** by nozzle replacement (full and low-burning nozzles) (see nozzle table).

The **symbols on the control** panel mean:

- 0 Off
- 🔥 Outer flame ring off  
Low position of inner flame ring
- 🔥 Outer flame ring off  
High position of inner flame ring
- 🔥 Low position of outer flame ring  
High position of inner flame ring
- 🔥 High position of outer and inner flame rings

The flame is infinitely variable between high and low-setting.

### Maintenance Instructions

- Keep appliance area clean and free from combustible materials, gasoline and other inflammable vapors and liquids.
- Do not obstruct the flow of combustion and ventilation air.
- Visually check burner flames with this pictorial representation (see figure 4).



### 3. Operation

**The cooking positions must only be ignited when all burner parts are fitted. Otherwise, malfunctions may occur on the ignition unit.**

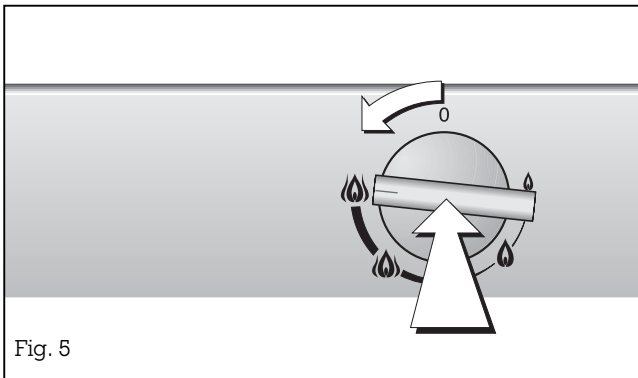

**Switching on (Fig. 5):**

- Place a pot or a pan on the corresponding cooking position.
- Press in the control knob fully and keep it pressed. This activates the ignition.
- Turn the control knob to the left to the "high" position.

If the flame should not ignite within **2 to 4 seconds**, turn the control knob further to the left to the "low" position and then back to the "high" position after ignition. It is often faster to ignite in the low position because the various gases have a differing ignition response.

Once the flame is burning, keep the control knob pressed for another **5-8 seconds**. The thermal sensor must be heated for 5-8 seconds before the knob can be released.

Repeat the operation if the flame should go out again.

The flame size can be set continuously between full and low by slowly turning the control knob.

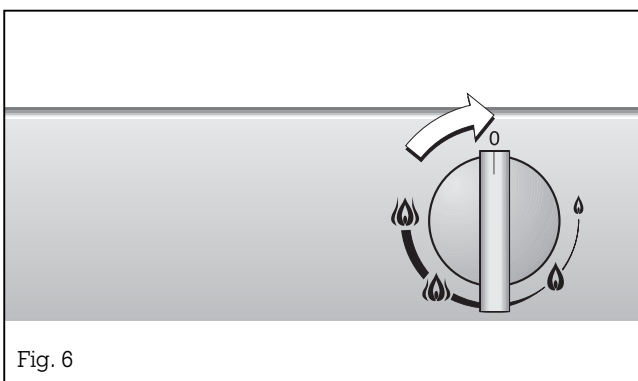

**Switching off (Fig. 6):**

Fully turn the control knob to the left to the 0 position on the left.

## 4. Cleaning and care

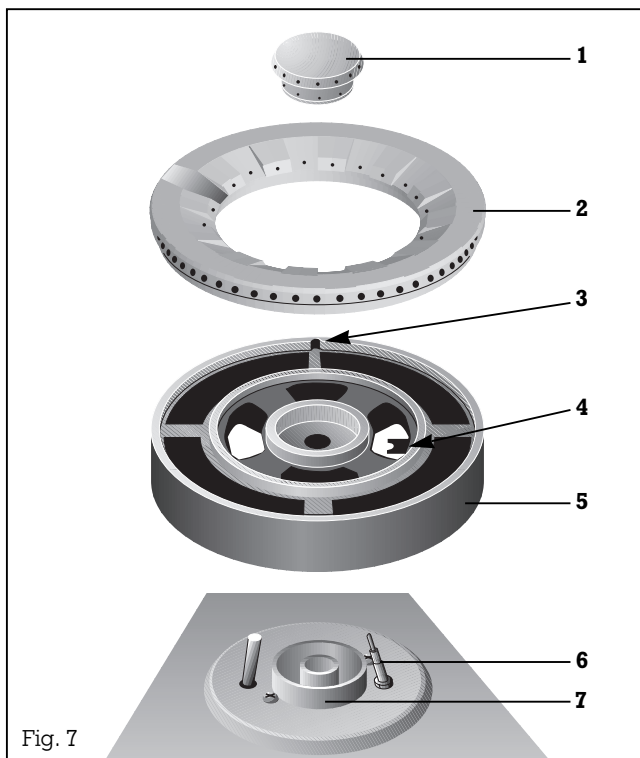

**Wipe off spilt food** immediately, thus ensuring that it cannot burn in on the hob.

**Caution!** The burner gets very hot during operation!

**Never use** abrasive or caustic cleaning agents.

Keep the **air inlet openings** on the rear of the panel unblocked and clean.

You should only clean the **control panel** and the **control knobs** with detergent and a soft cloth.

To ensure perfect functioning, keep the **thermal sensor** and the **spark plug** clean.

Please thoroughly clean the appliance **before operating it for the first time and after every use.**

- **Wait until the appliance has cooled down.**
- Remove the **pot grid.**
- Remove the **burner cover** and the **burner ring.**
- Clean the **hob, the burner covers and the pot grid** with commercially available cleaning agents (not in a dishwasher!), e.g. with warm soap solution and a dishwashing brush.
- Whenever required, clean the **burner head** with a moist cloth.
- Soak **burnt-in remainders** in a little water and detergent. This loosens even the most stubborn of soiling. Do not use any abrasive agents and abrasive sponges.
- As the result of heat development, slight discoloration can appear on the stainless steel surface. **Do not attempt to scrape away such discoloration.** This damages the surface. Distribute stainless steel care agents uniformly and thinly on the hob (not on the control panel!). This will ensure an even surface and will keep your hob in a good condition for a long period of time.

When assembling the appliance (Fig. 7), make sure that the burner head (5) is placed on the burner base (7) in such a way that the twist protector (4) is held in place by the thermal element (6). Place the burner ring (2) on the burner head (5) from above. The locking lug on the underside of the burner ring must fit in the recess (3). Place the burner cover (1) in the centre of the burner head. Fit the pot support.

### **Caution:**

Never use high-pressure or steam jet units to clean your appliance because otherwise the electrical safety of the appliance will no longer be guaranteed.

## 5. Maintenance

### 5.1 General

**The appliance must be disconnected from the power supply during all repair work.**

In the event of **malfunctions**, check whether the gas and electricity supply is in proper working order, i.e. the gas valve is open and the plug has been plugged into the socket.

If the power supply is functioning correctly, but your appliance still does not work, please contact your Gaggenau **dealer** who will provide you with the address and telephone number of your nearest manufacturer's authorized service agent or contact **Gaggenau USA on (800) 828-9165**. Specify the appliance type (see rating plate).

**Repairs** may only be carried out by **authorised technicians**, in order to guarantee the safety of the appliance.

Unauthorised tampering with the appliance will invalidate any warranty claims.  
Only ever use original spare parts.

### 5.2 Remediating slight malfunctions yourself

Fault	Remedy
The burner does not ignite after several attempts.	Check whether ... ... the burner is correctly assembled. ... the gas shut-off facility is open. ... the burner is clean and dry. ... the domestic fuse has tripped. If necessary, inform after-sales service.
The gas flame goes off after ignition.	Check whether ... ... the burner cover and the burner ring are correctly fitted. ... the flame has been extinguished by a strong draught in the room.
The cooking ring burner's electrical igniter is no longer functioning.	Check whether there are food remainders between the ignition electrode and the burner cover. Carefully remove these.
The flame tips are yellow and not blue.	Check whether the burner is dry and clean.

## 6. Technical data / Table

### Technical data (gas)

#### Burners: super strong burner

Level 1 low flame	< 850 BTU (0.25 kW)
Level 2 full inner flame	< 1 700 BTU (0.50 kW)
Level 3 small outer flame	
plus level 2 full inner flame	3 500 BTU (1.50 kW)
Level 4 full flame	17 000 BTU (5.00 kW)

### Technical data (electrical)

<b>Rated consumption</b>	0.8 W
<b>Voltage</b>	AC 120 V
<b>Frequency</b>	60 Hz

**Technical modifications reserved.**

### Gas connection:

R 1/2" union nut for R 1/2" bracket to DIN 1999,  
conical-cylindrical

### Technical data, gas

<b>Countries</b>	US CA	US CA
<b>Gas family</b>	Natural gas	Propane gas
<b>Gas type</b>	N	X
<b>Pressure</b>	6" W.C. (1.5 kPa)	10" W.C. (2.5 kPa)
<b>Outer burner, full</b>	<b>170 B</b>	<b>1.10</b>
<b>Outer burner Bypass</b>	<b>0.79</b>	<b>0.57</b>
<b>Inner burner, full</b>	<b>Nr. 44</b>	<b>Nr. 3</b>
<b>Inner burner Bypass</b>	<b>0.44</b>	<b>0.31</b>
<b>Air gap adj / outer [mm]</b>	<b>2</b>	<b>0</b>
<b>Air gap adj / inner</b>	<b>1/2 open</b>	<b>open</b>
<b>Σ Power</b>	17 000 BTU (5 kW)	17 000 BTU (5 kW)
<b>Σ Consumption</b>	0.48 m <sup>3</sup> /h	364 g/h

## 7. Practical tips

---

### 7.1 The wok and accessories

(not included in the scope of delivery)

- The "original wok" is the ideal wok for your gas cooker.
- The wok looks like a hollow hemisphere with a long handle or wooden handle. It has a rounded base and slanted sides. The thin steel passes the heat swiftly to the inside, but soon cools down again as soon as the flame is set to a lower setting. Therefore, ingredients cannot overcook.
- The diameter is between 35 - 40 cm / 14 - 15<sup>3</sup>/<sub>4</sub>" for 4 persons.
- Woks may consist of various materials. Cast-iron woks are more stable and keep the heat longer.
- They have a round, high cover. Therefore, they are also capable of steaming and stewing.
- The semicircular grid is hooked in on the edge of the wok. On it, you can steam ingredients, you can allow deep fried foods to drip or you can keep browned foods warm.
- Use the chan (rounded spatula) or the wooden pan reversing implement.
- Use a ladle to remove foods.
- Use the strainer to lift deep fried foods from the fat or large pieces out of a sauce.
- You can use bamboo baskets for steaming.

### 7.2 Cooking in the wok

You can fry, steam, deep fry, stew and cook normally.

Stir frying is the special cooking method for the wok. Ingredients cut into small pieces are cooked as briefly as possible under strong heat and constant stirring. In the large, round pan everything can be stirred and turned faster and with greater ease than in a conventional frying pan. Thanks to stirring, ingredients do not burn onto the pan. Surplus oil drains off towards the middle. In next to no time, you obtain delicious roasted foods, the pores in meat close and fish becomes nice and juicy. Vegetables stay crispy, and aromas and healthy vitamins are retained.

Important: the cooking time is so short that all ingredients should be ready for cooking before you begin. The correct sequence is also important. First place the ingredients with the longest cooking time in the wok. For example, these are hard-fibred vegetables such as carrots. Soft vegetables such as mushrooms or sprouts are added later.

#### Proceed as follows:

- Pour sufficient oil into the wok to coat the surface. We advise you to use peanut or or soya oil.
- Heat up the oil to just before the smoking point; only then begin with stir frying.
- Cut the food into pieces of equal size, but not too small, thus making sure they will not burn.
- If you are cooking larger quantities, work with portions as otherwise not all of the food will reach the hot base of the wok.
- Meals that are ready can be kept warm on a minimal flame. Clean the wok after every use and rub its inside with oil. This will prevent rusting.

---

## 7.3 Recipes

### Beef in oyster sauce

#### Ingredients for 4 persons

500 g fillet of beef  
1/2 teaspoon of black pepper (freshly ground)  
2 tablespoons of dark soya sauce  
1 tablespoon of wheat flour  
5 dried Tongku mushrooms  
300 g of oyster mushrooms  
2 spring onions, 1 fresh red chili  
4 cloves of garlic  
1 thumb-sized piece of fresh ginger  
3 tablespoons of oyster sauce, 1 tablespoon of fish sauce  
1 teaspoon of sugar, 4 tablespoons of rice wine

- Rinse the meat in cold water, dab it dry, remove tendons and skin, and cut it into approximately 1 cm cubes. Mix with pepper, soya sauce and flour and then marinate the mixture, covered up, for about one hour in the fridge.
- In the meantime, wash the Tongku mushrooms. Soak them in hot water for about 20 minutes.
- Clean the oyster mushrooms. Rinse them briefly in running water and cut them into large pieces.
- Wash the spring onions and cut them in half alongsides. Cut the spring onions into approximately 3 cm long pieces. Wash the chili and cut it in half alongside, remove the base of the stalk, remove the pips and cut it into strips.
- Wash your hands thoroughly!
- Peel the garlic and ginger and chop it up finely.
- Carefully squeeze out the Tongku mushrooms and quarter them.
- Heat oil in the wok. First sear the meat in portions, stirring it at the same time. Briefly roast the garlic and ginger and add the meat cubes. Reduce the heat. Add the Tongku and oyster mushrooms, spring onions, oyster and fish sauce and the sugar and allow to cook for about 2 minutes in medium heat.
- Add the chili strips and allow them to heat up. Stir in the rice wine. Garnish the meal with the chili strips.

### Chicken in basil and tomato sauce

#### Ingredients for 4 persons

100 g of shallots  
500 g of fillet of chicken breast  
750 g of tomatoes  
1 large bunch of basil  
2 tablespoons of oil  
200 g of crème fraîche  
salt  
freshly ground black pepper

- Peel the shallots and cut them into cubes. Rinse the fillets of chicken breast in cold running water and cut them uniformly into cubes.
- Score the tomatoes and place them briefly in boiling water or steam. Lift them out and skin them, then chop them into coarse cubes.
- If necessary, rinse the basil and shake it well to dry it, and then place a few leaves aside for garnishing. Cut or chop the others.
- Heat up the oil in the wok. While constantly stirring, sear the chicken meat in portions and remove it from the wok. Briefly roast the shallots until they are glassy. Add the meat.
- Add the chopped tomatoes and the crème fraîche to the wok. Stir all ingredients and spice them with the finely cut basil, salt and pepper. While stirring, simmer for a few minutes.
- Season the sauce with salt and pepper and serve the dish garnished with basil leaves.

Tip: if necessary, add to wine to the sauce to improve taste.

## 8. Assembly instructions

---

### 8.1 Important notes

Please observe the **safety notes** and the **important notes** (Chapter 1).

**The installing technician** is responsible for perfect functioning of the appliance at its installation location. He must explain the operating principle to the user with reference to the operating instructions and must show how to switch of the electricity and gas whenever required.

#### **Caution:**

Before connecting the appliance, please check whether the **local connection conditions** such as the gas type, gas pressure and mains voltage and the appliance settings are correct. Refer to the adhesive label on the gas connection or the **rating plate** for the necessary information. This gas hob conforms to the categories that are specified on the rating plate. The rating plate can be found on the appliance and additionally on the enclosed addendum sheet. By replacing nozzles, it is possible to set the appliance to any gas listed on the rating plate. If the data should not agree, the appliance must be set to the required gas type and the available pressure.

As this gas hob is not intended for connection to an exhaust gas system, pay attention to the applicable installation conditions.

#### **Note on ventilation:**

**To ensure good combustion, the room in which this appliance is installed must have a minimum volume of 10 m<sup>3</sup> and a door that opens out to outdoors or a window that can be opened.**

**Note: the appliance must not be combined with hob ventilators.**

**The appliance** may be installed in kitchen combinations made of wood or similar combustible materials without taking additional measures. The rear wall must consist of non-combustible material.

A minimum distance of **150 mm (6")** from heat-sensitive items of furnishing or contact surfaces (cupboard side panel) must be observed.

The hob conforms to appliance class 3 and must be installed in the worktop as shown in the installation sketch.

The distance between the suspended cupboard and the worktop must be at least **600 mm (24")**.

Attention must be paid to the manufacturer's specified safety clearance when a vapour extractor is installed.

Wall trims must be heat-resistant, and the minimum distance between the hob and the wall trim is at least **30 mm (1<sup>3</sup>/<sub>16</sub>")**.

After unpacking, check the appliance for any transportation damage and report this immediately to the transportation company.

**Technical modifications reserved.**

## 8.2 Connecting the appliance

### 8.2.1 Gas connection

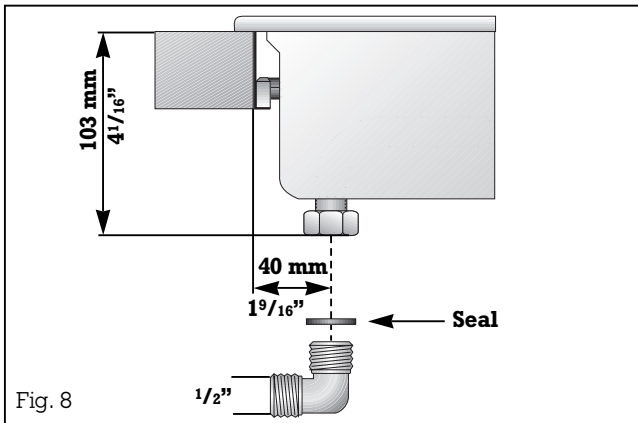

### 8.2.2 Electrical connection

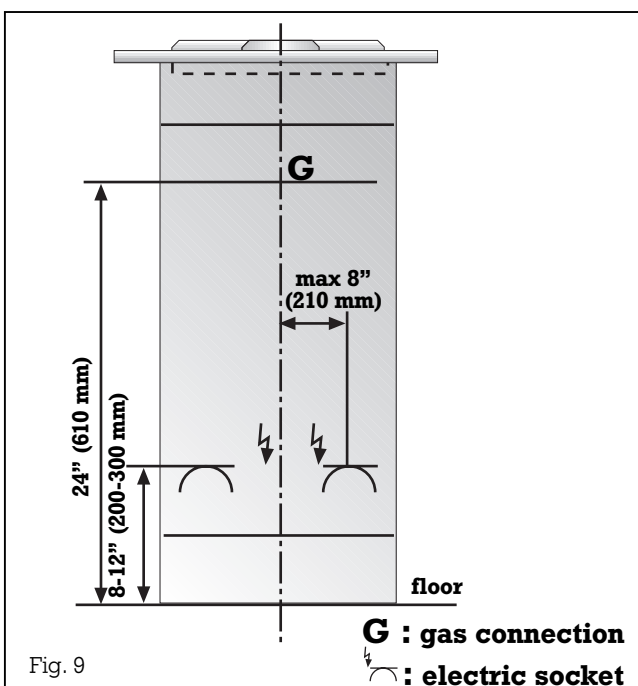

### Gas connection

The gas connection must be in a location that permits access to the shut-off valve and which, if applicable, is visible after opening the door of the furniture item.

By means of the included R 1/2" connection bracket (on the appliance end) with the affiliated washer, the appliance must be connected to a fixed connecting line or a gas safety hose to DIN 3383 Part 1 that corresponds to the type concerned. An ambient temperature of 70 °K must not be exceeded if the gas safety consists only partly of metal. The permissible ambient temperature for a gas safety hose that consists completely of metal is 115 °K.

If a flexible line is used, it must be laid in such a way that it cannot come into contact with moving parts of the kitchen element (e.g. drawer).

### Electrical connection

Electrical connection (AC 110-127 V) is established by means of a connecting cable with an earthing contact plug connected to an earthed socket, which must also be accessible after installation of the gas hob.

If, after installation of the gas hob, not all poles can be isolated from the mains by removing the plug, an isolating device with a contact gap of at least 3 mm must be permanently installed. When establishing connections, make sure that the connecting lead cannot come into contact with hot parts of the gas hob or other hot parts.

### Warning:

This appliance is equipped with a three prong grounding plug for your protection against shock hazard and should be plugged directly into a properly grounded receptacle. Do not cut or remove the grounding prong from this plug.



## 8.3 Nozzle replacement

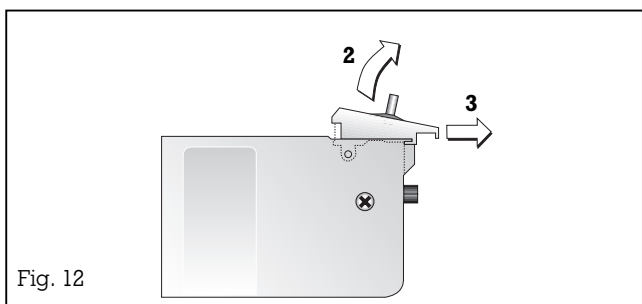
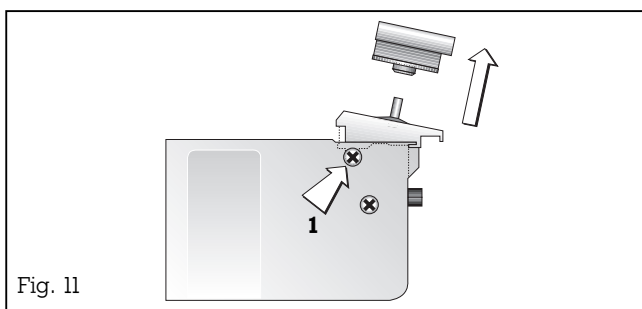
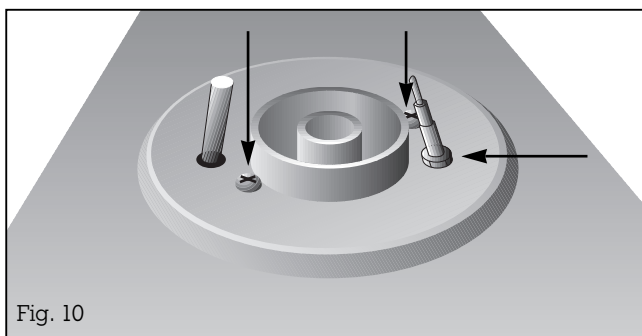

### Changing over to a different gas type

Only **authorised specialists** are permitted to change over to a different gas type. The nozzles needed for the gas type to be set are available as a conversion kit. Please specify the appliance type and the required gas type.

#### - **Disconnect the appliance from the power supply.**

- Remove the pot support, the burner ring, the burner cover and the burner head.
- If the appliance is connected rigidly to a gas main, it must be disconnected from the gas network. If it is connected via a gas safety hose, the appliance only needs to be pushed out of its mount from below and taken out of the worktop.
- Undo the securing nut (SW 11) of the thermocouple and the two securing screws that become visible under the detached burner head (Fig. 10).
- Remove the hob.
- Pull off the control knob. After undoing the securing screws **(1)** on the left and right (Fig. 11), you can remove the control panel by lifting **(2)** and pushing **(3)** it out of the latch (Fig. 12).

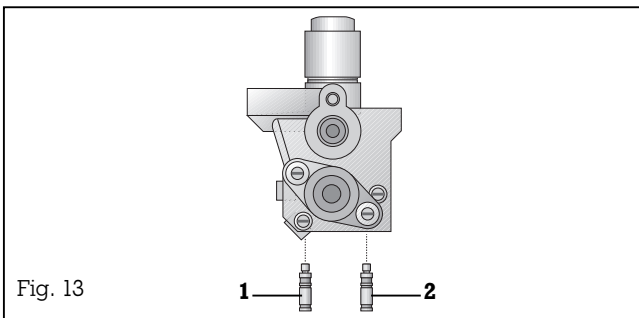

Fig. 13

### Replacing the low setting nozzles (Fig. 13)

The low setting nozzles for the inner (2) and outer (1) burners are located in the gas valve. They must be replaced according to the new gas type and as specified in the low setting nozzle table. Screw in the nozzles fully and check that they are tight (metallic seal).

If it should be necessary to correct the low-setting nozzles (1) and (2) as the result of deviating gas types and pressure, the flow rate can be increased by turning to the left.

See table on Page 12 for details of nozzle settings.

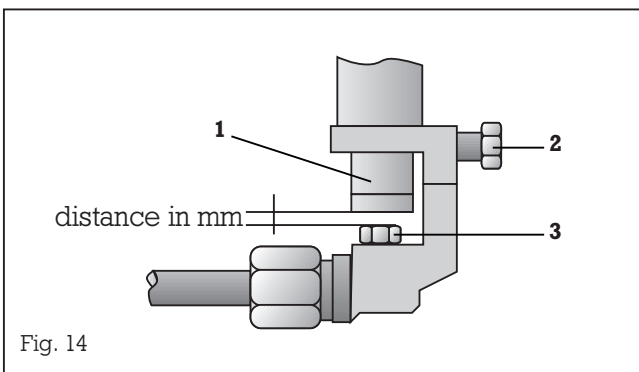

Fig. 14

### Replacing the main nozzles

#### Main nozzle replacement for the outer burner (Fig. 14)

Replace the main nozzle 3 (SW 10) for the high setting according to the new gas type and as specified in the nozzle table. Beforehand, loosen the screw 2 and push away the air regulation sleeve 1 and fix it in place with the screw 2. Check the absence of gas leaks on the installed main nozzle. According to the new gas type, stick the included adhesive label over the data specified on the gas connection.

Adjust the air gap according to the table entitled "Air gap adjustment" for the outer burner.

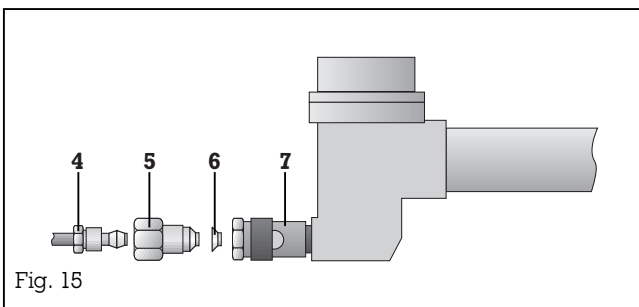
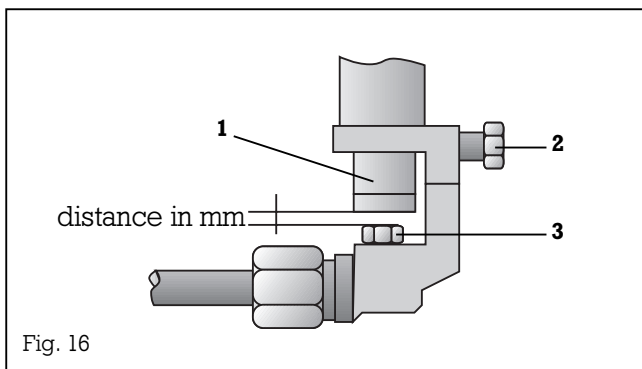

Fig. 15

#### Main nozzle replacement for the inner burner (Fig. 15)

Remove the supply line by undoing the union nut 4 (SW 8). Unscrew the injector screw 5 (SW 12) and, using a small screwdriver, remove the nozzle 6 from the injector 7. Install the nozzle according to the new gas type (see data in the nozzle table). To do this, fit the nozzle 6 on the front of the injector screw 5 and screw both of them into the injector. Plug in the supply line and screw it in. Check for the absence of leaks. Adjust the air gap as detailed in the table entitled "Air gap for inner burner".

**Caution:** the flame must neither go off nor flash back when you change over swiftly from the high to the low setting.



### First air regulation

First air regulation may be necessary to always achieve a stable and low-noise flame in the event of deviating gas types and pressures.

#### First air regulation for outer burner (Fig. 16)

After undoing the screw **2** (7 mm), move the air regulation sleeve **1** in the direction of the nozzle **3** or away from the nozzle up to a maximum distance of 12 mm until the flames burn stably and with low noise. Yellow tips must not be visible in the flames. The flame must not go off when you switch swiftly from the high to the low setting. Firmly screw in the screw **2** again.

See table on Page 12 for details of nozzle settings.

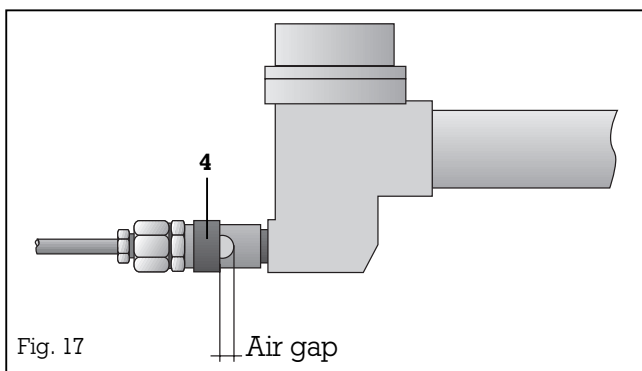

#### First air regulation for outer burner (Fig. 17)

The throttle spring **4** is generally positioned on the hexagon shaft. If required, shift the throttle spring. For exact details, refer to the table entitled "Air gap for inner burner". **The air gap must never be entirely sealed off.**

## 8.4 Installing the appliance

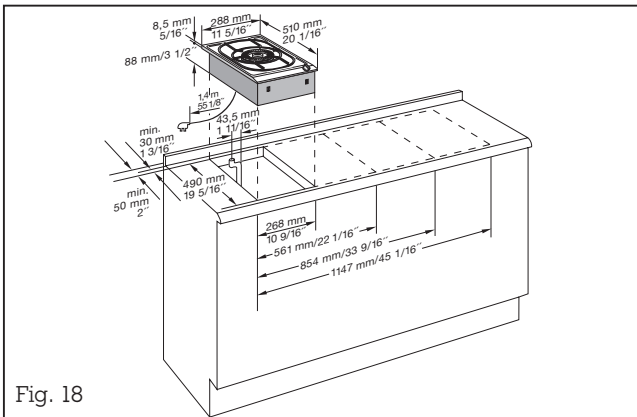

Fig. 18

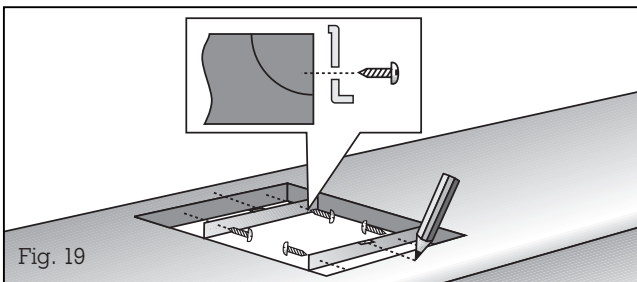

Fig. 19

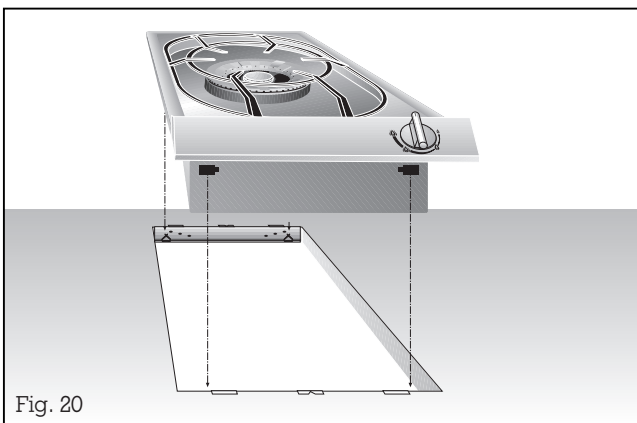

Fig. 20

– **Produce the recess for one or several Vario appliance(s) in your worktop.** Proceed as indicated on the installation sketch and the dimension table. The dimension table contains details of the space requirement for the trim between the appliances.

**Important:** the angle between the cut surface and the worktop must amount to 90° (Fig. 18).

– **Mark the centre of the recess exactly.** Secure the securing rails on the front and rear edges of the recess. Make sure that the lugs of the securing rails lie on the worktop and that the centre marking of the securing rails is precisely flush with the centre marking on the worktop (Fig. 19).

Secure the cover on the appliance **before installation.** See assembly instructions VD 201-010.

– **Lower the appliance into the worktop.** Make sure that the engaging lugs on the appliance lie exactly on the clamping springs. Press the appliance firmly into the worktop. The engaging lugs on the appliance “snap” into the clamping springs (Fig. 20).

**Note:** When installing the appliance in granite or marble worktops, have the holes produced by a specialist or stick on the securing rails with a temperature-resistant 2-component adhesive (metal on stone).

**Note:**

Several appliances can also be installed in individual recesses, as long as a minimum clearance of 40 mm (1<sup>9</sup>/<sub>16</sub>”) is kept to between the appliances.

Operating and assembly instructions

# VG 231 CA

Gas cooker



**GAGGENAU**

## Free Manuals Download Website

<http://myh66.com>

<http://usermanuals.us>

<http://www.somanuals.com>

<http://www.4manuals.cc>

<http://www.manual-lib.com>

<http://www.404manual.com>

<http://www.luxmanual.com>

<http://aubethermostatmanual.com>

Golf course search by state

<http://golfingnear.com>

Email search by domain

<http://emailbydomain.com>

Auto manuals search

<http://auto.somanuals.com>

TV manuals search

<http://tv.somanuals.com>