

Apollo[®]
Model SL30 NAV/COMM
Installation Manual

August 2003
560-0404-03a



© 2003 Garmin AT, Inc. All rights reserved.
Printed in the USA

No part of this document may be transmitted, reproduced, or copied in any form or by any means without the prior written consent of Garmin AT, Inc. Due to Garmin AT's commitment to constantly improve the quality and performance of our products, information contained in this document is subject to change without notice.

Garmin AT, Inc. and Apollo are registered trademarks of Garmin AT, Inc.

Garmin AT, Inc.
PO Box 13549
Salem, OR 97309

2345 Turner Rd. SE
Salem, OR 97302
USA

Phone 503.581.8101
800.525.6726
In Canada 800.654.3415
Fax: 503.364.2138

HISTORY OF REVISIONS

Revision	Date	Description
--	11/16/99	Initial release (EN6278).
01	2/10/00	Added interface wiring diagrams, refined post installation checkout procedures.
02	8/2/01	New mounting tubes, dual SL30's, DST info to Apollo GX (EN 6949). SW Version 1.2
03	2/21/02	Added helicopter environmental qualification information.
03a	8/26/03	Changed logo and added JTSSO information.

IMPORTANT NOTE

“The conditions and tests required for TSO approval of this article are minimum performance standards. It is the responsibility of those desiring to install this article on or within a specific type or class of aircraft to determine that the aircraft operating conditions are within TSO standards. The article may be installed only if further evaluation by the applicant documents an acceptable installation and is approved by the Administrator.” Follow installation recommendations as noted in AC20-67B, *Airborne VHF Communications Equipment Installations*.

Source: FAA TSO-C34e, TSO-C36e, TSO-C37d, TSO-C38d, TSO-C40c, TSO-C66c, and TSO-C128.

ORDERING INFORMATION

To receive additional copies of this publication, order part # **560-0404-03a**, *Apollo SL30 NAV/ COMM Installation Manual*.

REFERENCE PUBLICATIONS

Following are other publications referenced in this guide.
Apollo SL30 NAV/ COMM Operation Manual, order part # **560-0403-xx**.

NOTES

TABLE OF CONTENTS

SECTION 1 - INTRODUCTION	1
ABOUT THIS MANUAL	1
APOLLO SL30 DESCRIPTION	1
FEATURES	2
GENERAL FEATURES	2
NAVIGATION RADIO FEATURES	2
COMM RADIO FEATURES	3
PHYSICAL SPECIFICATIONS	3
NAV RADIO PERFORMANCE SPECIFICATIONS	3
COMM RADIO PERFORMANCE SPECIFICATIONS	3
SYSTEM INTERFACES	4
NAVIGATION RECEIVER	4
COMM TRANSCEIVER	4
SERIAL INTERFACE	4
REGULATORY COMPLIANCE	4
UNPACKING THE EQUIPMENT	5
PACKAGE CONTENTS	5
OTHER REQUIRED MATERIALS	6
SPECIAL TOOLS REQUIRED	6
LICENSE REQUIREMENTS	7
SECTION 2 - INSTALLATION.....	9
PRE-INSTALLATION INFORMATION	9
INSTALLATION OVERVIEW	9
INSTALLATION CONSIDERATIONS	9
MOUNTING CONSIDERATIONS	9
MINIMUM SYSTEM CONFIGURATION	9
EQUIPMENT MOUNTING	10
MOUNTING TUBE INSTALLATION	10
UNIT INSERTION	12
UNIT REMOVAL	12
ELECTRICAL CONNECTIONS	14
POWER	14
AVIONICS OUTPUTS	14
SERIAL INTERFACE	14
SPEAKER AND HEADPHONE OUTPUTS	14
MICROPHONE INPUTS	15
TRANSMIT KEY INPUT	15
INTERCOM SELECTOR SWITCH	15
REMOTE FLIP/FLOP INPUT	15
ANTENNA INSTALLATION AND CONNECTIONS	15
COMM AND NAV ANTENNAS	15
USE OF SPLITTER AND COMBINER	16
EQUIPMENT INTERFACE	17
LIMITATIONS ON USING A COMPOSITE SIGNAL	33
LIMITATIONS ON DISTANCE, SPEED, AND TIME INFORMATION	33
POST INSTALLATION CHECKOUT	33
MOUNTING / WIRING CHECK	33

SETUP AND CHECKOUT.....	33
FINAL SYSTEM CHECK	37
INSTRUCTIONS FOR CONTINUED AIRWORTHINESS	40
SECTION 3 - SPECIFICATIONS.....	41
ELECTRICAL	41
PHYSICAL	41
ENVIRONMENTAL	41
AVIONICS OUTPUTS	42
NAV RECEIVER PERFORMANCE	43
VOR	43
LOCALIZER.....	43
GLIDESLOPE	44
OBS RESOLVER	44
COMPOSITE OUTPUT.....	44
COMM RECEIVER PERFORMANCE	45
COMM TRANSMITTER PERFORMANCE.....	45
INTERCOM PERFORMANCE	46
CONTROL INPUTS.....	46
ANTENNA REQUIREMENTS.....	46
COMM ANTENNA.....	46
NAV ANTENNA.....	46
SERIAL INTERFACE	47
REAR CONNECTOR PINOUT	47
SECTION 4 - LIMITATIONS	49
INSTALLATION	49
COMPUTATION RATES	49
OPERATIONAL.....	49
APPENDIX A - TROUBLESHOOTING	51
CONTACTING THE FACTORY FOR ASSISTANCE.....	52
APPENDIX B - PERIODIC MAINTENANCE	53
VOR CHECKS	53
EQUIPMENT CALIBRATION.....	53
REFERENCE OSCILLATOR (COMM ONLY).....	53
CLEANING THE FRONT PANEL.....	53
APPENDIX C - ENVIRONMENTAL QUALIFICATIONS.....	55
APPENDIX D - ACCESSORIES	57
FROM GARMIN AT, INC.	57
APPENDIX E - SERIAL INTERFACE SPECIFICATIONS	59
INPUT COMMANDS.....	59
OUTPUT MESSAGES	59
DATA FORMAT.....	60
DEFAULT MESSAGE OUTPUT	60
MESSAGE FORMATS.....	60

MESSAGE DEFINITIONS	61
INPUT MESSAGES	61
REMOTE VOR LIST	62
REMOTE LOCALIZER LIST	64
REQUEST DATA OUTPUT	66
SET ACTIVE VOR/LOC FREQUENCY AND RECEIVER FUNCTION	67
SET STANDBY VOR/LOC FREQUENCY AND RECEIVER FUNCTION	67
SET STANDBY COMM FREQUENCY AND TRANSCEIVER FUNCTION	68
SET ACTIVE COMM FREQUENCY AND TRANSCEIVER FUNCTION	68
SET NAV AUDIO MODE	69
SET OMNI-BEARING SELECT (OBS) VALUE	69
DME SENSOR INPUT	70
OUTPUT MESSAGES	70
RESET STATUS	70
CDI, GSI, AND RELATED FLAGS	71
DECODED OBS SETTING	72
RADIAL FROM ACTIVE VOR	72
RADIAL FROM STANDBY VOR	72
DECODED STATION IDENTIFIER	73
COMMUNICATIONS ERROR	73
NAV RECEIVER STATUS	74
NAV AUDIO MODE	74
NAV MICROCONTROLLER SOFTWARE VERSION	75
NAV DSP SOFTWARE VERSION	75
ADC DATA OUTPUT	75
COMM TRANSCEIVER STATUS	76
COMM SOFTWARE VERSION	76

LIST OF TABLES

TABLE 1 - PACKAGE CONTENTS.....	5
TABLE 2 - COMM INTERFACE CONNECTOR PINOUT	47
TABLE 3 - REAR PANEL CONNECTOR PINOUT	48
TABLE 4 - TROUBLESHOOTING GUIDE	51
TABLE 5 - DATA OUTPUT REQUESTS	66

LIST OF ILLUSTRATIONS

FIGURE 1 - SL30 FRONT PANEL	2
FIGURE 2 - FULL STACK MOUNTING TUBE SPACING.....	11
FIGURE 3 - CAM LOCK POSITIONING.....	12
FIGURE 4 - MOUNTING FRAME ASSEMBLY	13
FIGURE 5 - CABLE ROUTING	13
FIGURE 6 - REAR COAX CONNECTOR ASSEMBLY	16
FIGURE 7 - SL30 COMM WIRING DIAGRAM.....	18
FIGURE 8 - SL30 COMM TYPICAL AUDIO PANEL CONNECTIONS	19
FIGURE 9 - SL30 NAV POWER AND AUDIO CONNECTIONS	20
FIGURE 10 - SL30 TO APOLLO GX50/60 CONNECTIONS	20
FIGURE 11 - SL30 - GX50/60 - MX20 CONNECTIONS	21
FIGURE 12 - SL30 NAV TO MID-CONT MD200-306/307.....	22
FIGURE 13 - SL30 NAV TO MID-CONT MD200-302/303 CONNECTIONS	23
FIGURE 14 - SL30 NAV AND ACU TO MID-CONT MD200-306/307	24
FIGURE 15 - SL30 NAV TO STEC IND-351A CONNECTIONS	25
FIGURE 16 - SL30 NAV TO BENDIX/KING KN72/203/204/208/208A/209/209A WIRING	26
FIGURE 17 - SL30 NAV TO BENDIX/KING KI202/206/525A/KPI552 WIRING.....	27
FIGURE 18 - SL30 NAV TO SANDEL DISCRETE CONNECTIONS.....	28
FIGURE 19 - SL30 NAV TO SANDEL SN3308 CONVERTER CONNECTIONS	29
FIGURE 20 - SL30 TO SPERRY RD 550A AND RD650 WIRING	30
FIGURE 21 - SL30 TO COLLINS 331A-6P, 331A-9G, AND PN-101 WIRING	31
FIGURE 22 - SL30 TO CENTURY NSD 360A AND NSD 1000 WIRING.....	32
FIGURE 23 - UNIT DIMENSIONS.....	42

SECTION 1 - INTRODUCTION

ABOUT THIS MANUAL

This manual describes the installation of the Apollo SL30 Nav/Comm units. It is intended for use by persons certified by the Federal Aviation Administration (FAA) to install aircraft navigation devices. It includes installation and checkout procedures for the SL30 unit to standards described in FAA advisory circulars AC 20-67B (for Comm).

Section 1 Provides an **introduction** to the Apollo SL30 unit. TSO certification information is also included in this section.

Section 2 Includes **installation** and checkout procedures.

Section 3 Includes complete **specifications**.

Section 4 Includes **limitations** for the equipment and installation.

Appendix A Includes **troubleshooting** information.

Appendix B Includes **periodic maintenance** requirements.

Appendix C Includes the **environmental qualification form**.

Appendix D Includes information on **accessories**.

Appendix E Includes **serial data specifications**.

APOLLO SL30 DESCRIPTION

The Apollo SL30 includes a 760-channel VHF Comm transceiver and 200-channel VOR/LOC/GS navigation receiver with DME display.

The Apollo SL30 is a member of the Apollo slimline series which includes the SL10/15 Audio Selector Panels, SL40 Comm, SL50 GPS, SL60 GPS/Comm, and SL70 Transponder.

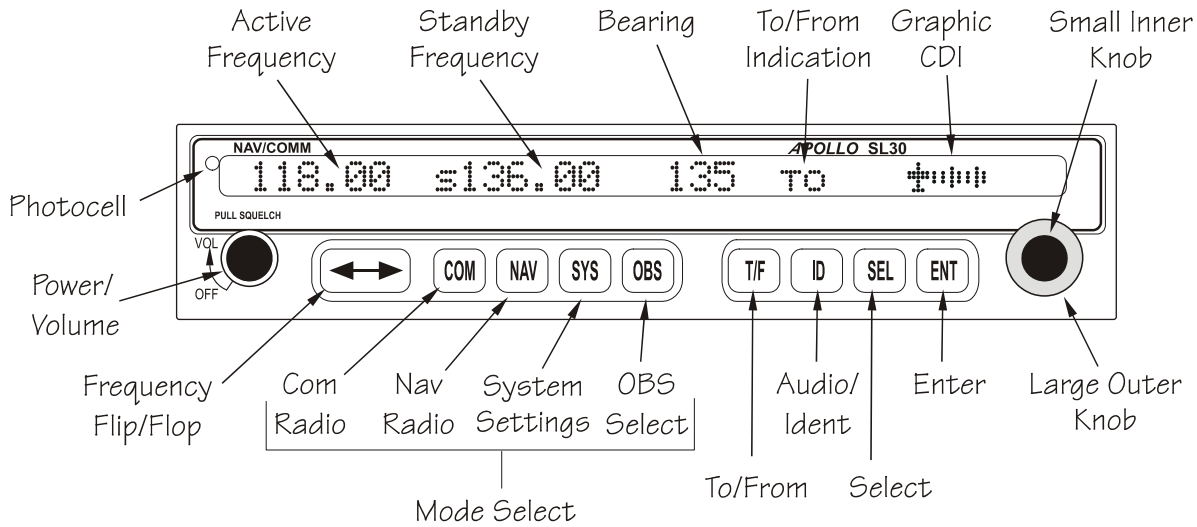

Figure 1 - SL30 Front Panel

FEATURES

GENERAL FEATURES

- 32 character high-intensity alphanumeric LED display
- Sunlight readable full alphanumeric display
- Automatic display intensity
- Back-lit buttons
- 200 channel memory (stored alphabetically)
- Remote frequency flip-flop input pin

NAVIGATION RADIO FEATURES

- 200 channel Nav with solid state DSP technology
- VOR/Localizer and Glideslope receivers
- Built-in VOR/Localizer converter
- Frequency range:

VOR	108.00 – 117.95 MHz
Localizer	108.00 – 111.95 MHz
Glideslope	328.60 – 335.40 MHz
- Digitally decoded OBS setting
- Manual selection of back course approach
- Automatic display of station ID by decoding Morse code
- Interfaces to most CDI (w/resolver), HSI, and autopilot systems
- VOR receiver displays To or From radial of the active channel
- VOR monitor displays From radial of the standby channel
- Back course annunciator output
- LOC enable annunciator output

- Internal RF diplexor
- Active and standby flip/flop frequencies
- DME tuning and data display

COMM RADIO FEATURES

- 760 communications channels
- Frequency range 118 to 136.975 MHz
- Active and standby flip/flop frequencies
- Volume control
- Tunes to National Weather Service broadcasts
- Transmit status indicator
- Frequency monitor function (listens to standby while monitoring active)
- Emergency channel menu
- Squelch test function
- Stuck Mic time-out
- 12 watt audio amplifier
- Includes two-place VOX intercom

PHYSICAL SPECIFICATIONS

- 1.3"(H) x 6.25" (W) x 10.5" (D)
- Weight 2.25 lbs. (unit only)
- Depth 11.452 inches (29.09cm) behind panel, including mounting frame and connectors

NAV RADIO PERFORMANCE SPECIFICATIONS

- Input voltage range 10 to 40 VDC
- Operating temperature range -20°C to $+55^{\circ}\text{C}$
- Certified TSO C34e/JTSO C34e (Glideslope receive)
- Certified TSO C36e/JTSO C36e (ILS Localizer receive)
- Certified TSO C40c/JTSO 2C40c (VOR receive)
- Certified TSO C66c/JTSO 2C66b (DME display)

COMM RADIO PERFORMANCE SPECIFICATIONS

- Input voltage range 10 to 40 VDC
- Operating temperature range -20°C to $+55^{\circ}\text{C}$
- Transmit power 8 watts (Carrier Power)
- Certified TSO C37d/JTSO 2C37e (Comm transmitting)
- Certified TSO C38d/JTSO 2C38e (Comm receiving)
- Certified TSO C128/JTSO 2C128 (stuck mic)

SYSTEM INTERFACES

NAVIGATION RECEIVER

The SL30 can be installed in several configurations based upon individual requirements. This includes with or without an external course deviation indicator. The CDI may be discrete, serial, or composite.

COMM TRANSCEIVER

For standalone installations, the Comm requires connections to:

- a standard Comm antenna
- a microphone (or microphones)
- a speaker or headphone
- power input

These items may be installed dedicated to the SL30 Comm, or by connection to an audio panel. The system can be configured to mix the NAV audio with the Comm audio if no external audio panel is used.

SERIAL INTERFACE

- DME – Distance Measure Equipment
- SL/GX – GPS products
- MX – Multi-Function Display

REGULATORY COMPLIANCE

The Apollo SL30 is designed and tested to meet the following TSOs/JTSOs:

- FAA TSO-C37d/JTSO 2C37e for Comm transmit
- FAA TSO-C38d/JTSO 2C38e for Comm receive
- FAA TSO-C128/JTSO 2C128 for unintentional transmission (stuck mic)
- FAA TSO-C34e/JTSO C34e for ILS Glideslope receive
- FAA TSO-C36e/JTSO C36e for ILS Localizer receive
- FAA TSO-C40c/JTSO 2C40c for VOR receive
- FAA TSO-C66c/JTSO 2C66b for DME display

The Apollo SL30 complies with the FCC requirements specified in:

CFR 47, Part 87, Aviation Services, Subpart D, Technical Requirements

The Apollo SL30 complies with the FCC requirements specified in:

CFR 47, Part 15, Radio Frequency Devices, Subpart B, Unintentional Radiators

The Apollo SL30 software is designed and tested to RTCA/DO-178B, level C and ED-12B, level C.

Note: Unauthorized changes or modifications to the SL30 may void the compliance to required regulatory agencies and authorization for continued equipment usage.

UNPACKING THE EQUIPMENT

Carefully unpack the equipment. Visually inspect the package contents for any evidence of shipping damage. Retain all shipping containers and packaging material in case reshipment is necessary.

PACKAGE CONTENTS

As shipped from the Garmin AT factory, the Apollo SL30 package includes most items necessary for installation other than supplies normally available at the installation shop, such as wire and cable ties, and required input and output equipment. The standard items included in the package are listed in Table 1.

Table 1 - Package Contents		
Part #	Description	Qty
430-6040-3xx	SL30 NAV/COMM	1
Install kits	Part number: 424-2006-300	
162-1575	15-pin d-sub connector shell	1
162-1577	37-pin d-sub connector shell	1
162-1008	Right angle coax plug	2
202-0001	Cable tie	2
204-0037	Edge grommet	6"
204-2100	Shoulder bushing	4
221-0400	4-40 x 1/4 SS pan head Phillips machine screw with lock washer	8
224-0404	4-40 x 1/4 SS flat head Phillips machine screw	4
245-0027	Crimp contact for d-sub, 20 to 24 awg wire	50
310-5181-xx or 310-5197-xx	Mounting frame NOTE: Only 310-5197-xx is qualified for helicopter use.	1
310-5192-xx	Connector mounting plate	1
998-0048	3/32 hex driver	1
Manual kits	Part number: 564-0064-300	-4xx
560-0403-xx	SL30 User's Manual	1
560-0404-xx	SL30 Installation Manual	1
561-0262-xx	SL30 Quick Reference Guide	1
Accessories		
115-0007	NAV signal splitter/combiner	Optional
S712-0007-012	Internal 3 amp slow blow fuse	Optional

Note: Package contents may vary depending on how the unit is ordered.

OTHER REQUIRED MATERIALS

The SL30 is intended for use with standard aviation accessories. External devices required for various installations are listed below. Depending upon the installation, this will include items such as:

- back course annunciator
- a CDI or HSI
- a Comm antenna
- NAV antenna
- NAV antenna splitter (if dual SL30)
- a microphone(s)
- a speaker or headphone
- audio panel

SPECIAL TOOLS REQUIRED

Crimp Tool

A crimp tool meeting MIL specification M22520/1-01 and a positioner/locator are required to ensure consistent, reliable crimp contact connections for the rear 15-pin and 37-pin connectors. These tools are available from:

For pin P/N 245-0022

Astro Tool Corp.
21615 SW TV Highway
Beaverton, OR 97006

Phone (503) 642-9853
Fax (503) 591-7766

Crimp tool:

Astro Tool part #615708

Positioner:

Astro Tool part #616356

For pin P/N 245-0027

ITT Cannon
1851 E. Deere Ave.
Santa Ana, CA 92705-6500

Phone (714) 261-5300
Fax (714) 575-8324

Insertion tool:

ITT part # 274-7006-000 (Desc. CIET-20HD)

Regular duty Crimp tool:

ITT part #995-0001-585 (Desc. M22520/1-01)

Regular duty Locator tool:

ITT part #995-0001-244 (Desc. TH25)

Heavy duty Crimp tool:

ITT part #995-0001-584 (Desc. M22520/2-01)

Heavy duty Locator tool:

ITT part #995-0001-604 (Desc. M22520/2-08)

LICENSE REQUIREMENTS

An aircraft radio station license may be required for operation of the SL30 Comm transmitter once installed in the aircraft. An application must be submitted on FCC Form 404, Form 605 or later revised application, which may be obtained from the FCC in Washington, DC, or any of its field offices. Procedures for applications are in CFR 47, Part 87, Aviation Services, Subpart B, Applications and Licenses.

NOTES

SECTION 2 - INSTALLATION

This section describes the installation of the SL30 including mounting, wiring, and connections. A post installation check-out procedure is included at the end of this section.

PRE-INSTALLATION INFORMATION

Always follow good avionics installation practices per FAA Advisory Circulars (AC) 43.13-1B, 43.13-2A, and AC 20-67B, or later FAA approved revisions of these documents.

Follow the installation procedure in this section as it is presented for a successful installation. Read the entire section before beginning the procedure. Perform the post installation check-out before closing the work area in case problems occur.

INSTALLATION OVERVIEW

A successful installation should start with careful planning including determination of mounting location for the SL30, antenna mounting, connections to microphones, speakers, and headphones, cable routing, and other required modifications. Once the mounting location has been determined, prepare the mounting frame for installation. It may be easier to complete the wiring harness and attach the connectors to the mounting frame before installing the mounting frame.

INSTALLATION CONSIDERATIONS

MOUNTING CONSIDERATIONS

The SL30 is designed to mount in the avionics stack in the aircraft instrument panel within easy view and reach of the pilot. The standard package includes a mounting frame for ease of mounting, connections, and service of the unit. Allow an additional one-inch clearance to the rear of the mounting frame for connectors and cables.

For typical installations, the SL30 does not require external cooling. When mounting the unit, leave a clearance of 1/8 to 1/4 inch between avionics to allow for air circulation.

MINIMUM SYSTEM CONFIGURATION

VFR Installation

VFR installation need only include an SL30 with power, audio, and antenna connections. Without an external CDI, no glideslope information is obtainable. However, the unit will maintain full VOR and Localizer functionality including an internal CDI display.

IFR VOR/LOC Installation

IFR installation requires:

- SL30
- External CDI/HSI indicator that meets the following criteria:
 1. The course deviation indicator shall have an input impedance of 1 k ohm \pm 10% and a deflection sensitivity of 150 mV \pm 10% for full scale deflection.
 2. The valid flag shall have an input impedance of 1 k ohms \pm 10%.

3. The valid flag sensitivity shall be $125 \text{ mV} \pm 10\%$ for the flag to leave the stop and $260 \text{ mV} \pm 10\%$ maximum for flag to be fully concealed.
4. The To/From flag shall have an input impedance of $200 \text{ ohms} \pm 10\%$ and a sensitivity of $\pm 40 \text{ mV} \pm 15\%$ at 25°C with flag fully in view.
5. The OBS resolver should be compatible with a standard 6-wire OBS interface:
 - HReference output high
 - C.....Reference output low
 - DS1 COS input high
 - E.....S3 COS input low
 - FS4 SIN input high
 - GS2 SIN input low

Any electrical zero crossing will work because the SL30 will calibrate out any errors.

Glideslope Installation

Glideslope installation requires:

- SL30
- External non-numeric glideslope indicator that meets the following criteria:
 1. The glideslope deviation shall have an input impedance of $1 \text{ k ohm} \pm 10\%$ with a deflection sensitivity of $150 \text{ mV} \pm 10\%$ for full scale deflection.
 2. The glideslope valid flag shall have an input impedance of $1 \text{ k ohm} \pm 10\%$.
 3. The glideslope valid flag sensitivity shall be $125 \text{ mV} \pm 10\%$ for the flag to leave the stop, and $260 \text{ mV} \pm 10\%$ maximum for flag to be fully concealed.

Helicopter Requirements

The SL30 is qualified for helicopter installation with certain mount tube and SL configurations (see Section 4 – Limitations).

EQUIPMENT MOUNTING

Once the cable assemblies have been made, attach the 15- and 37-pin d-sub and coaxial cable connectors to the rear connector mounting plate and the mounting frame as illustrated in Figure 4 and Figure 5. Route the wiring bundle as appropriate. The rear connector plate should be attached to the mounting frame before installing the frame in the instrument panel. The rear connector plate can be used to tie down the cable assemblies. Use the supplied edge guard to protect the cable from sharp edges. Connect the shield grounds directly to the connector mounting plate.

Once the cable assemblies are complete and the connectors are attached to the mounting frame, install the mounting frame assembly in the instrument panel as illustrated in Figure 2. Be sure to use low-profile head screws in the side of the mounting frame so the unit will slide in and out freely. Attach the front of the mounting frame to the instrument panel. Use support brackets to attach the rear of the frame to the aircraft.

MOUNTING TUBE INSTALLATION

Care must be taken when installing the mounting tube to ensure you can properly insert and secure the unit. There must be a minimum vertical spacing of 0.040 inches between units to prevent interference with the cam locking mechanisms. Mounting tubes with clearance

dimples help maintain the proper clearance. The mounting tube must be installed with the clearance dimples pointing up.

The mounting tube should be flush to the instrument panel and allow sufficient clearance for the back of the bezel of the unit to mount flush to the mounting tube. Sufficient clearance must exist in the instrument panel opening to allow ease of insertion and removal of the unit. **If the back of the unit bezel does not mount flush to the mounting tube, the connector may not engage fully.**

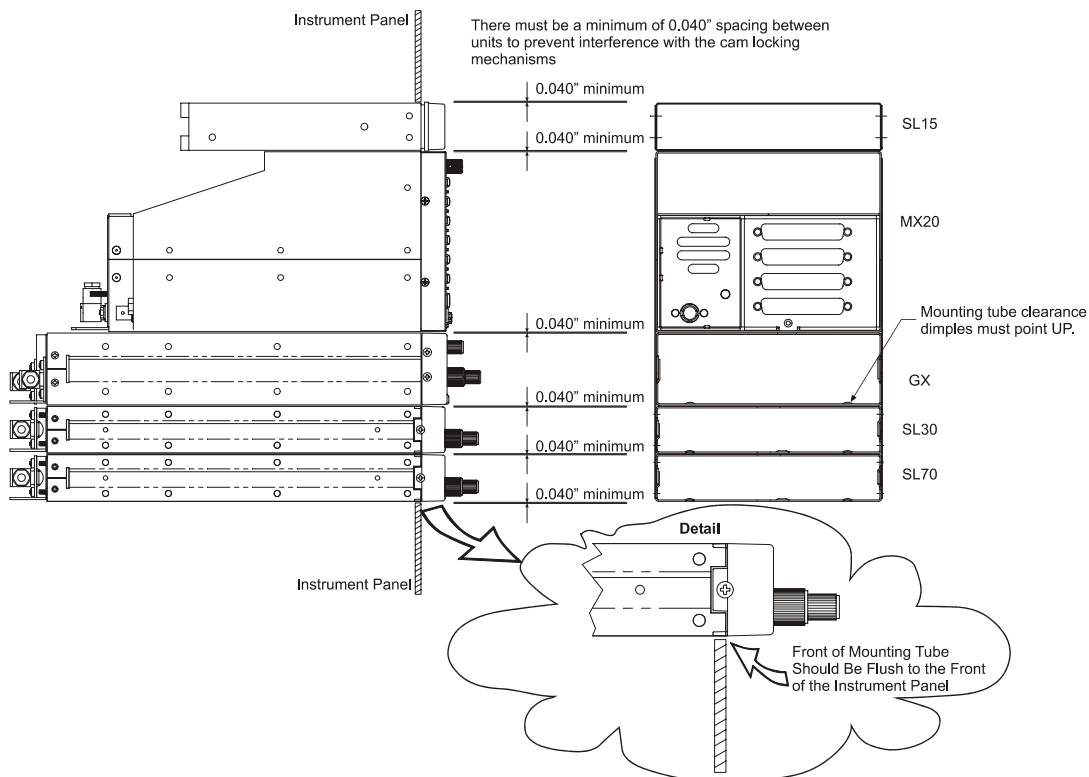

Figure 2 - Full Stack Mounting Tube Spacing

Secure the mounting tube to the instrument panel structure. Mounting screw heads must not protrude into the mounting tube. Be sure to use the appropriate screws so the unit will slide in and out freely. The screws attaching the mounting tube to the instrument panel structure must not interfere with the insertion of the unit. Failure to prevent interference will result in damage to the unit or prevent its insertion. Take care that the mounting tube is not distorted when it is attached to the instrument panel and structural supports. Shims may be necessary to properly install the mounting tube. If the mounting tube is distorted out of square, the unit may either bind when being inserted or the cam lock may not engage.

UNIT INSERTION

Position the cam lock as shown below. The front lobe of the cam should be vertical. The cam lock mechanism should be fully unscrewed (turned counter-clockwise). Slide the unit into the frame. Turn (clockwise) and carefully **hand-tighten** (4 in-lb max.) the cam lock mechanism using **only** the 3/32" hex driver provided in the installation package. Using a larger tool than the one provided makes it easy to exceed the allowable torque on the cam lock resulting in damage to the unit. The unit will be pulled into the frame securing the unit and the connectors when fully engaged. **Do NOT overtighten.** The back of the bezel must be flush to the mounting tube. If the cam lock is hard to turn or the unit does not seat fully, the unit is probably binding and the mounting tube should be checked.

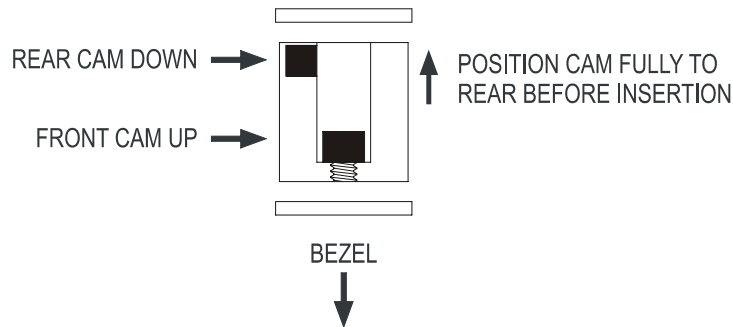

Figure 3 - Cam Lock Positioning

UNIT REMOVAL

To remove the unit from the mounting frame, turn the screw counter-clockwise with the hex driver to unscrew the cam lock mechanism. The unit will begin to pull away from the mounting tube. Turn the screw until slight resistance is felt and then pull the unit from the frame. **Do not exert excessive turning force at the end of the cam lock travel or the unit may be damaged.** With the cam lock fully disengaged, pull the unit straight out holding onto the sides of the bezel. It is not recommended that you pull the unit out by the rotary knobs. No special extraction tools are required, if the mounting tube is properly installed.

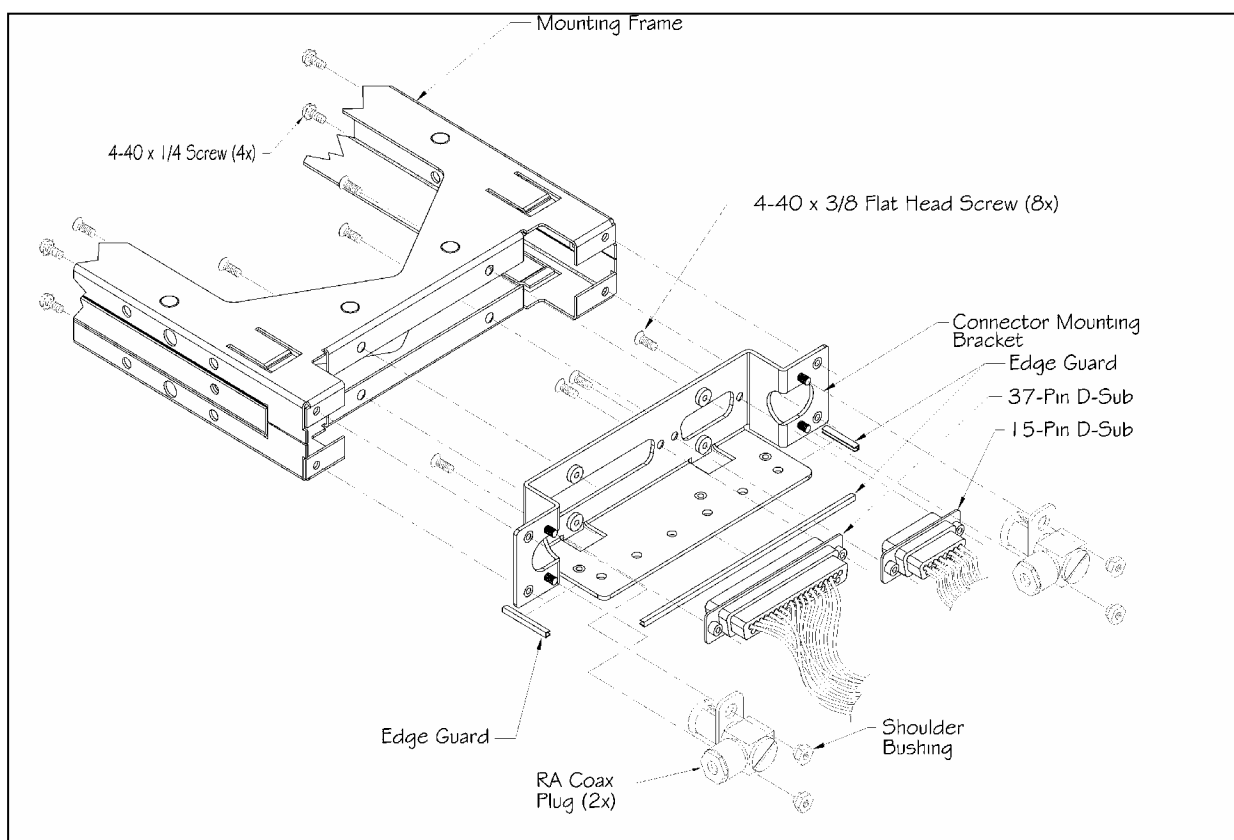

Figure 4 - Mounting Frame Assembly

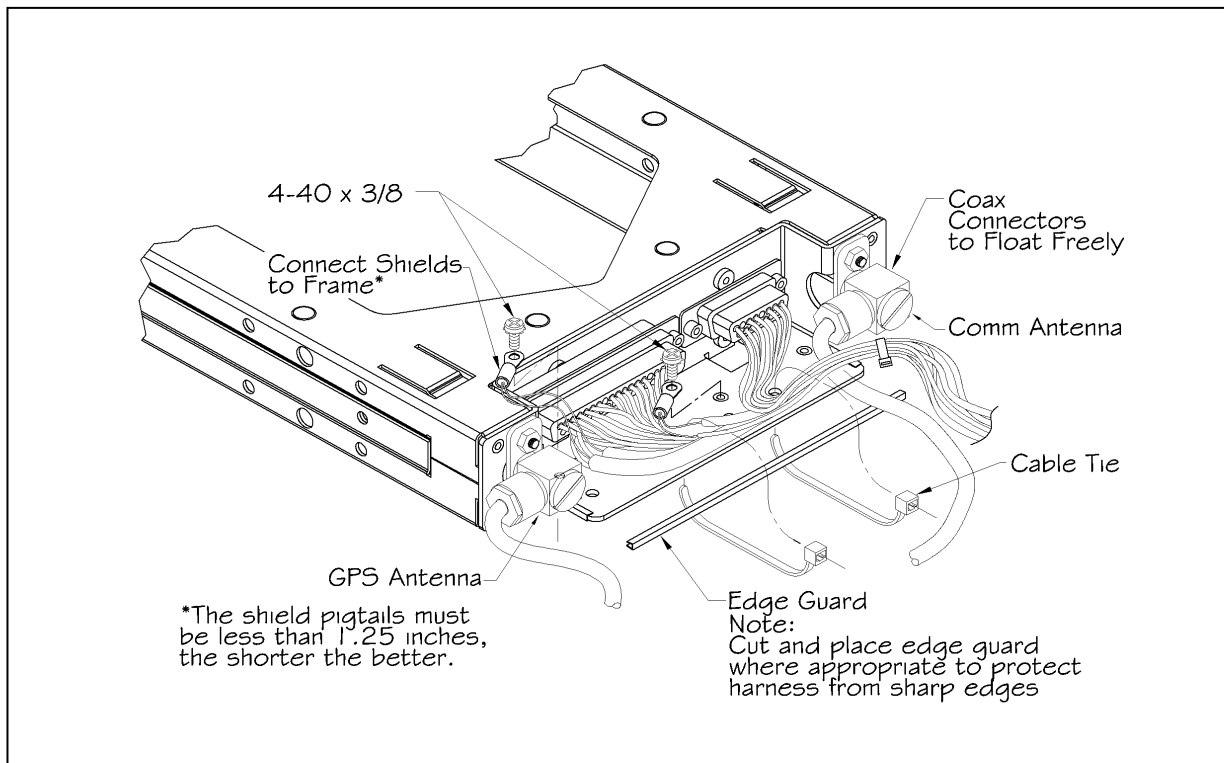

Figure 5 - Cable Routing

ELECTRICAL CONNECTIONS

The SL30 installation kit includes 15- and 37-pin d-sub shells and crimp contacts. The crimp contacts are specified for 20 to 24 awg wire. Make the crimp connections with a crimp tool as specified on page 6. All wires should be 20 to 24 AWG unless otherwise specified. Wiring diagrams are included in this section.

POWER

The SL30 requires two power connections, one for the Nav side of the unit, the other for the Comm. Make the power connections to the unit using 20 awg wire.

The Comm power input is internally fused at 7 amps. A separate 5 amp circuit breaker or fuse should be installed for downline overload or short circuit protection.

The NAV internal fuse is 3 amps. A separate 2 amp circuit breaker or fuse should be installed for downline overload or short circuit protection.

***Note:** Circuits should be protected in accordance with guidelines in AC 43.13-1B, chapter 11, section 4.*

Warning

When connecting power to the unit, reversing the polarity of the connection will blow the internal fuse. The internal fuse requires replacement at the factory or factory authorized repair center.

AVIONICS OUTPUTS

The SL30 includes a complete avionics interface for resolvers, CDI/HSI indicators, autopilot, and back course annunciator. These outputs are to be connected as appropriate for the particular installation. The CDI/HSI outputs may be connected to a dedicated CDI or HSI or to a shared indicator using an appropriate switching relay, such as an Apollo ACU. The avionics outputs available are listed in the Avionics Outputs specification on page 42. Connect the annunciator outputs as necessary.

SERIAL INTERFACE

The SL30 includes an RS-232 serial port for making optional connections. The serial port can be used for connecting to:

- Resolvers, indicators, or electronic flight instruments that accept serial data
- GX series units for Comm/NAV frequency transfers from the database
- MX20 to display VOR data on a map and database interface
- RMI/DME control box allows DME tuning, DME display, and OBI output

When making connections to the SL30, use a three conductor shielded cable. Make RxD, TxD, and signal ground connections to the 37-pin connector. Connect the shield(s) to the rear of the mounting frame on the connector plate. The shield leads must be < 1.25 inches.

Complete serial interface specifications are included in Appendix E – Serial Interface Specifications.

SPEAKER AND HEADPHONE OUTPUTS

Connect the speaker and headphones to the output pins on the rear connector.

MICROPHONE INPUTS

Microphone input connections should be made using a twisted pair shielded cable. Attach the signal ground to the mic ground pin on the rear connector and connect the shield to the rear connector plate.

TRANSMIT KEY INPUT

The TxKey input on the rear connector must be pulled low to ground to enable the transmitter. This input should be connected to a microphone or yoke mounted momentary push button switch.

INTERCOM SELECTOR SWITCH

The SL30 includes a voice activated intercom function that can be enabled by an external control switch. This is an optional connection.

When making connection for the intercom selection, connect the intercom selection input to a remote mounted normally open switch (an alternate action switch can be used). Connect the other terminal of the switch to ground. The intercom function is enabled when the input is pulled low to ground.

REMOTE FLIP/FLOP INPUT

The SL30 includes a remote flip/flop input. This is an optional input that can be connected to a remote mounted (such as on the yoke) momentary push button switch which pulls the input low to ground. The remote flip/flop input will only toggle the Comm frequencies when Comm frequencies are displayed and will only toggle NAV frequencies when NAV frequencies are displayed.

ANTENNA INSTALLATION AND CONNECTIONS

COMM AND NAV ANTENNAS

The SL30 requires a standard 50 Ω vertically polarized Comm antenna and a horizontally polarized NAV/VOR/Localizer/Glideslope antenna. Follow the antenna manufacturer's installation instructions for mounting the antennas. The Comm antenna should be a standard Comm antenna that operates on Comm frequencies between 118.00 and 137.000 MHz. The NAV antenna should be a VOR/Localizer/Glideslope NAV antenna that receives VOR frequencies between 108 and 117.95 MHz, and localizer frequencies between 108 and 112 MHz and glideslope information between 328.6 and 335.4 MHz.

The NAV and Comm antennas should also be mounted as far apart as practical from the ELT antenna, preferably one on top and the other on the bottom of the aircraft fuselage. Some ELTs have exhibited re-radiation problems generating harmonics that may interfere with GPS signals. This can happen when the Comm (SL40 or any other Comm) is transmitting on certain frequencies such as 121.15 or 121.175 MHz, which may cause the ELT output circuit to oscillate from the signal coming in on the ELT antenna coax.

The antenna coax cable should be made of RG-142B or a comparable quality 50 Ω coax. Assembly instructions for the rear coax connector are included in Figure 6.

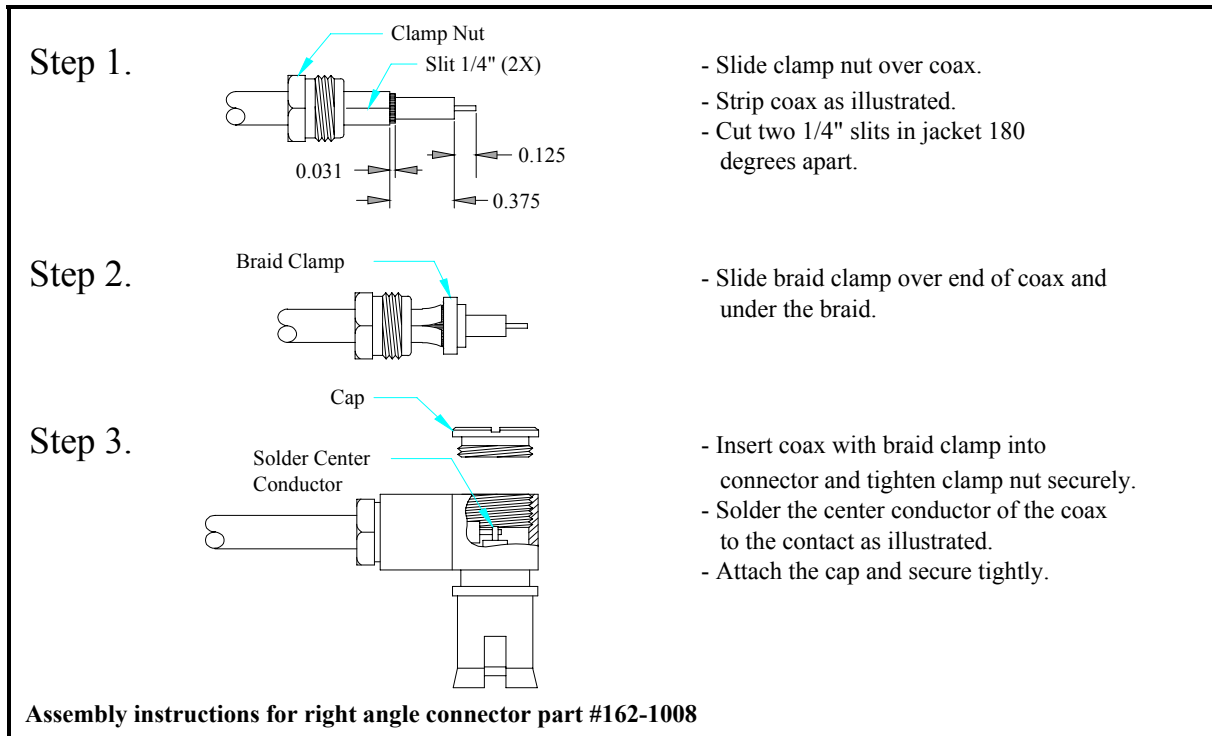

Figure 6 - Rear Coax Connector Assembly

USE OF SPLITTER AND COMBINER

The SL30 is the smallest, most advanced NAV/Comm unit on the market. Its size dictates room for only one Comm antenna input and one NAV antenna input. It incorporates an internal diplexor circuit. This means that the input VHF signal must not strip the glideslope (330 MHz) signal from the NAV (108 MHz) signal. **Do not install an external diplexor.**

It is recommended that a single VOR/Localizer/Glideslope antenna be used for the installation. Most VOR/LOC-only antennas will still provide an adequate glideslope signal for the Apollo SL30 to operate normally. In rare cases, it may be necessary to combine antenna signals. When the signals are combined, the systems overall performance may be slightly degraded, but the glideslope signal may increase to an acceptable level.

Dual Antennas

If separate VOR and glideslope antennas are used on the aircraft, a splitter/combiner must be used.

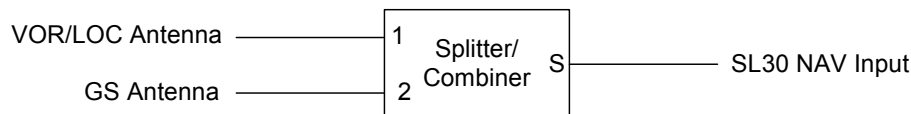

Dual SL30s

If dual SL30s are installed in the aircraft, a splitter must be used.

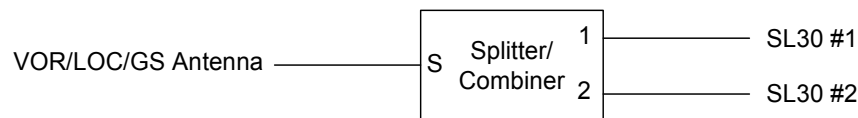

Dual Antennas and Dual SL30s

If dual SL30s and separate VOR and glideslope antennas are installed in the aircraft, a combiner and a splitter must be used.

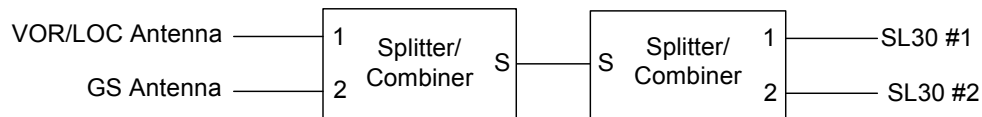

Installations should use an appropriate splitter/combiner, such as the Mini-Circuits ZFSC-2-1B BNC, available as an option under the Garmin AT part number 115-0007. This unit has been fully environmentally qualified for use with single and dual SL30 installations.

EQUIPMENT INTERFACE

Figure 12 through Figure 22 illustrate typical equipment configurations. SL30 installation is not limited only to equipment shown. The installer must ensure each article interfaced to the SL30 meets the interface specification listed in this manual.

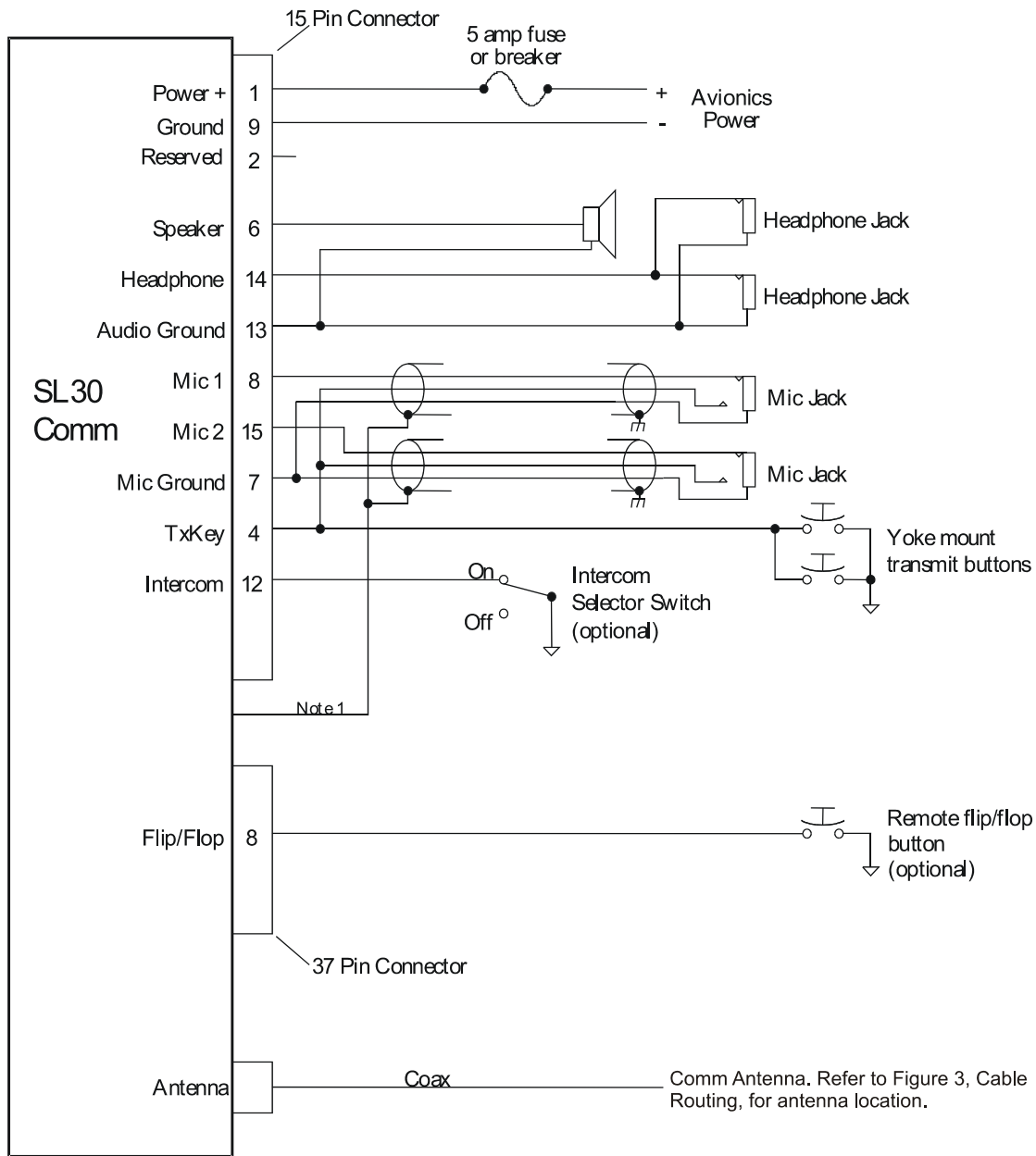

- Notes: 1. Connect cable shields to the rear of the mounting frame, with pigtails < 1.25 inches.
 2. Use shielded cable for the microphone connections.
 3. Connect shields to ground at both ends of cables.

Figure 7 - SL30 Comm Wiring Diagram

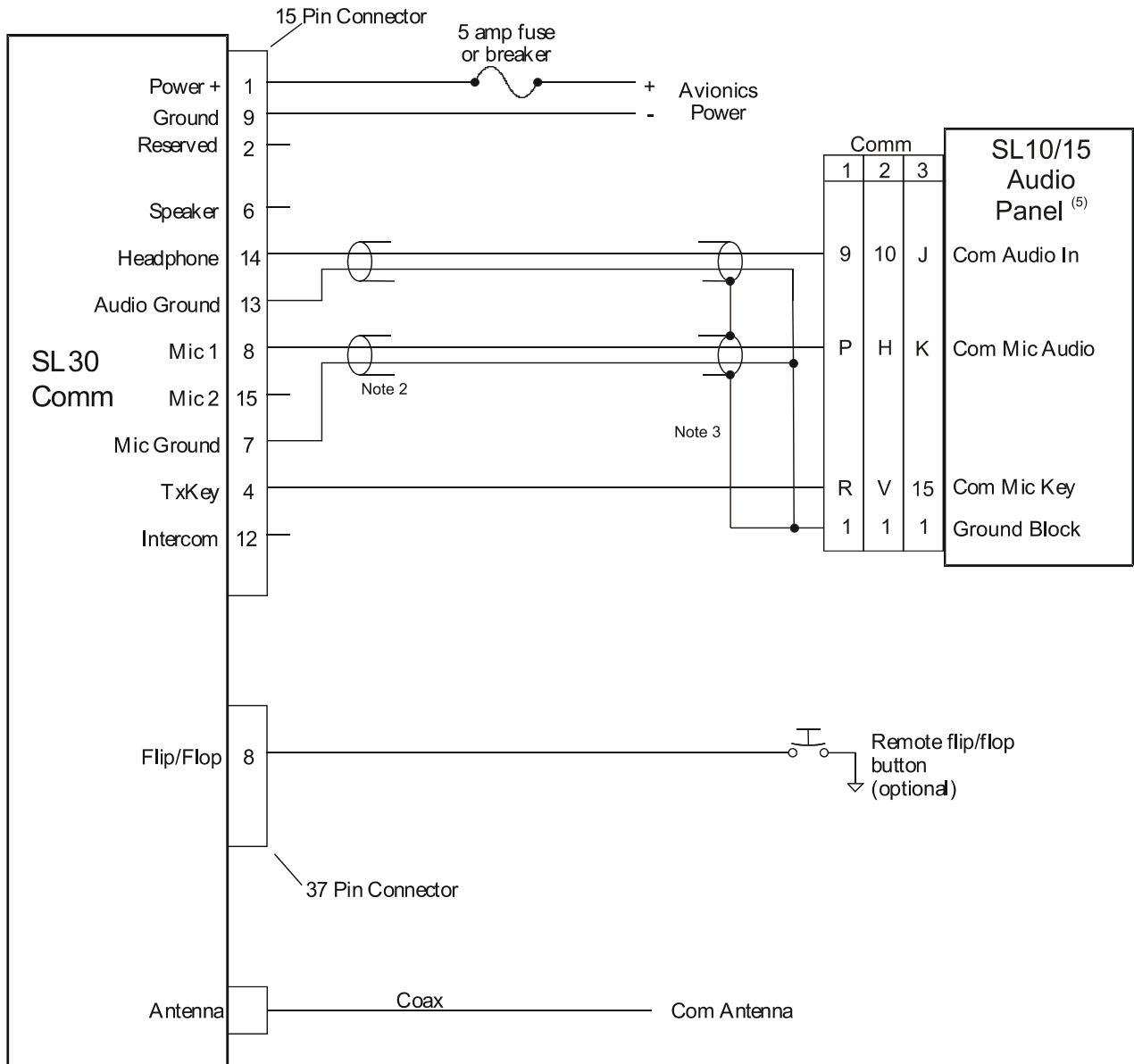

- Notes: 1. Use shielded cable for the microphone connections and audio.
 2. Mic and audio shields may be left floating at the SL30.
 3. Connect shields to the designated ground block on the SL10/15.
 4. Other equivalent parts may be interfaced to the SL30. See appropriate installation manuals for that equipment.

Figure 8 - SL30 Comm Typical Audio Panel Connections

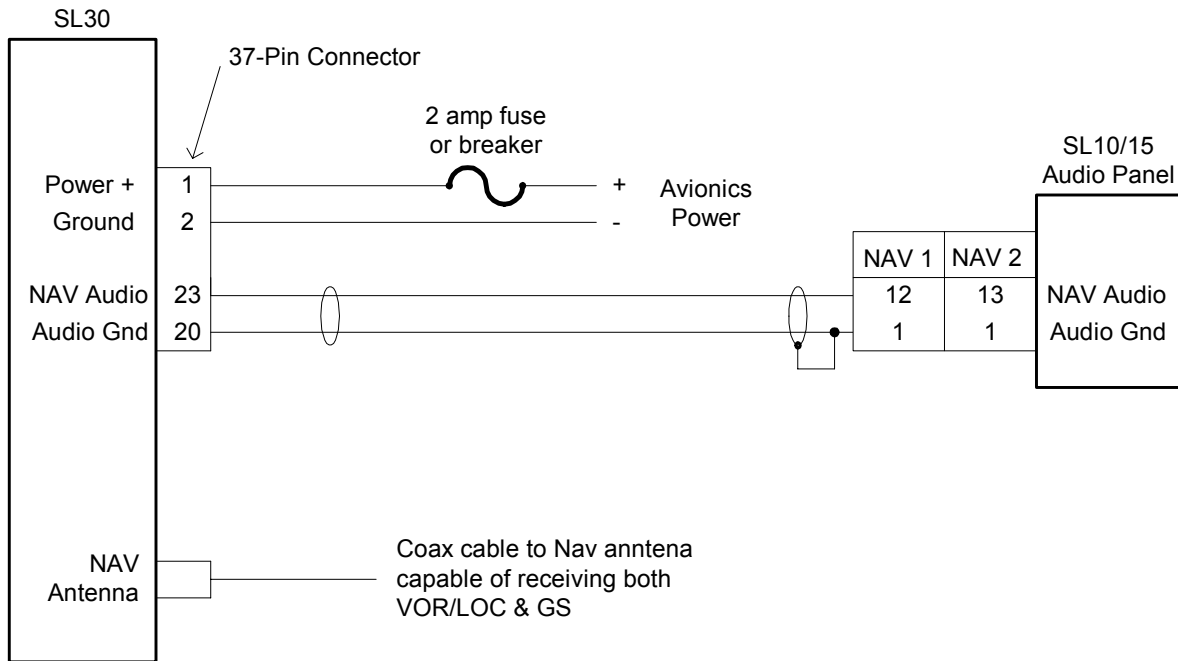

- NOTES:
1. Nav Audio may be left floating at the SL30.
 2. Connect shields to designated ground block at the SL10/15.
 3. Avionics power leads should use 20 awg wire. All others are specified at 22-24 awg.
 4. For NAV antenna location, refer to Figure 3, Cable Routing.

Figure 9 - SL30 NAV Power and Audio Connections

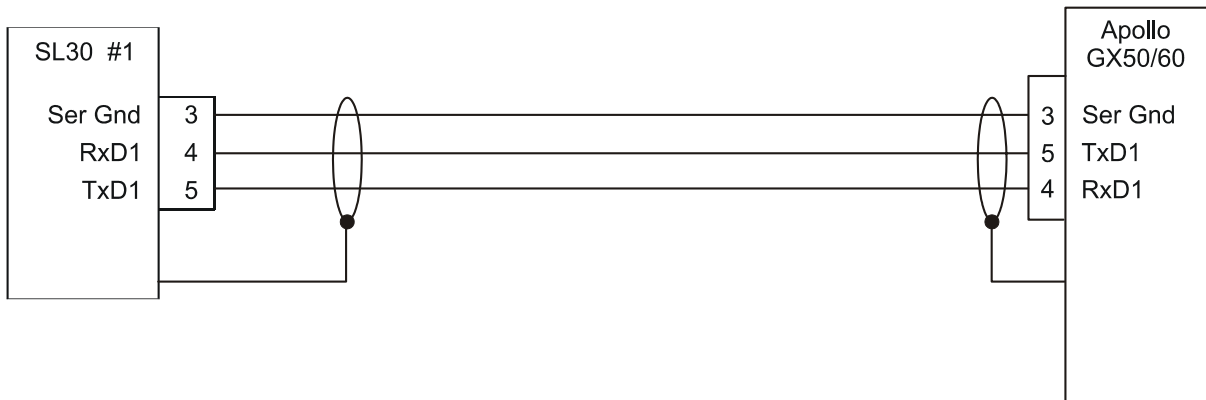

- NOTES:
1. Connect cable shields to the mounting frame: pigtails < 1.25 inches
 2. Connect shields chassis ground at both ends of each shielded cable.

Figure 10 – SL30 to Apollo GX50/60 Connections

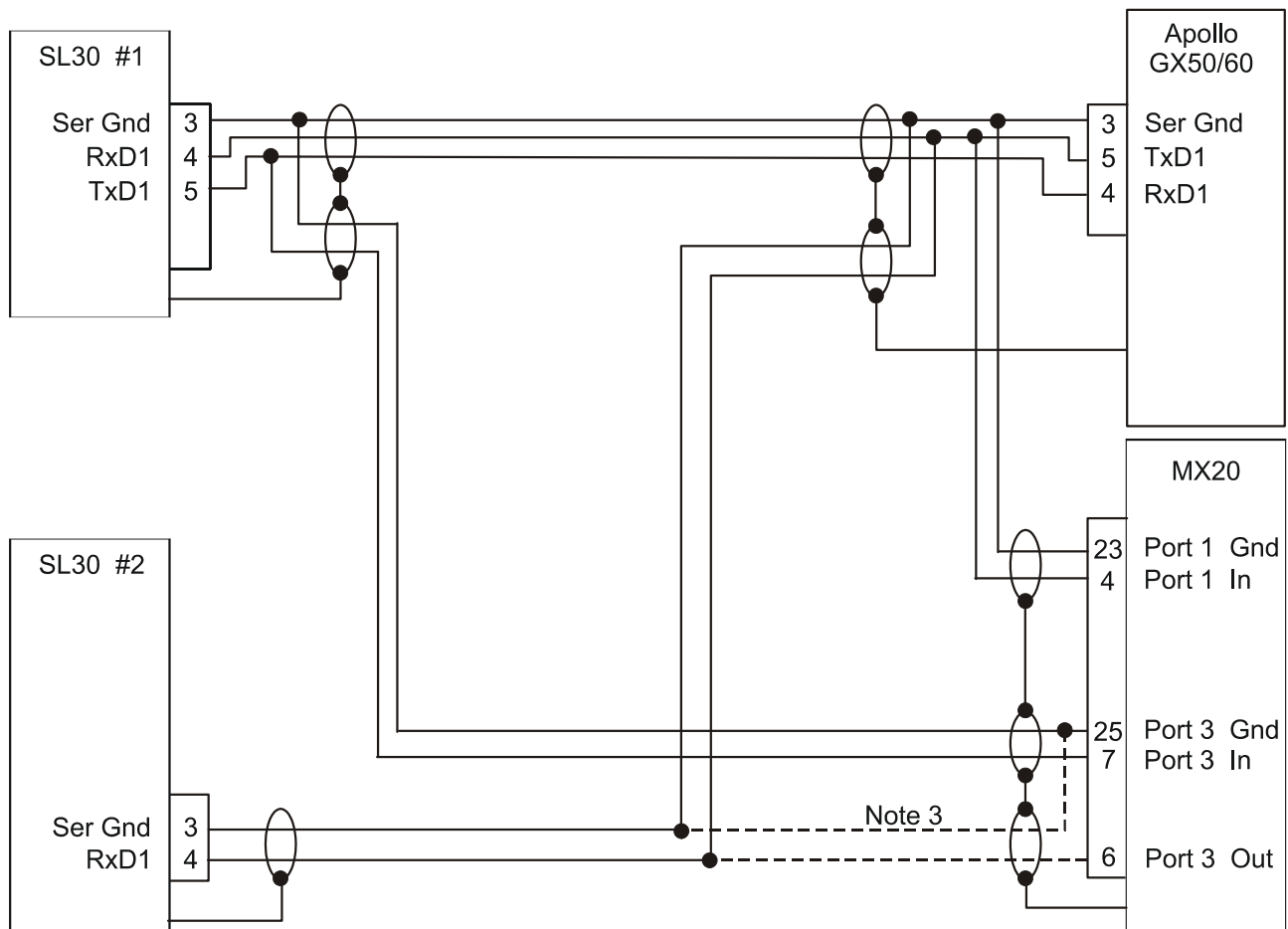

- NOTES:
1. Connect cable shields to the mounting frame: pigtails < 1.25 inches
 2. Connect shields chassis ground at both ends of each shielded cable.
 3. SL30 #2 may be connected to MX20 Port 3 Out to reduce the fan out of the GX.

Figure 11 - SL30 - GX50/60 - MX20 Connections

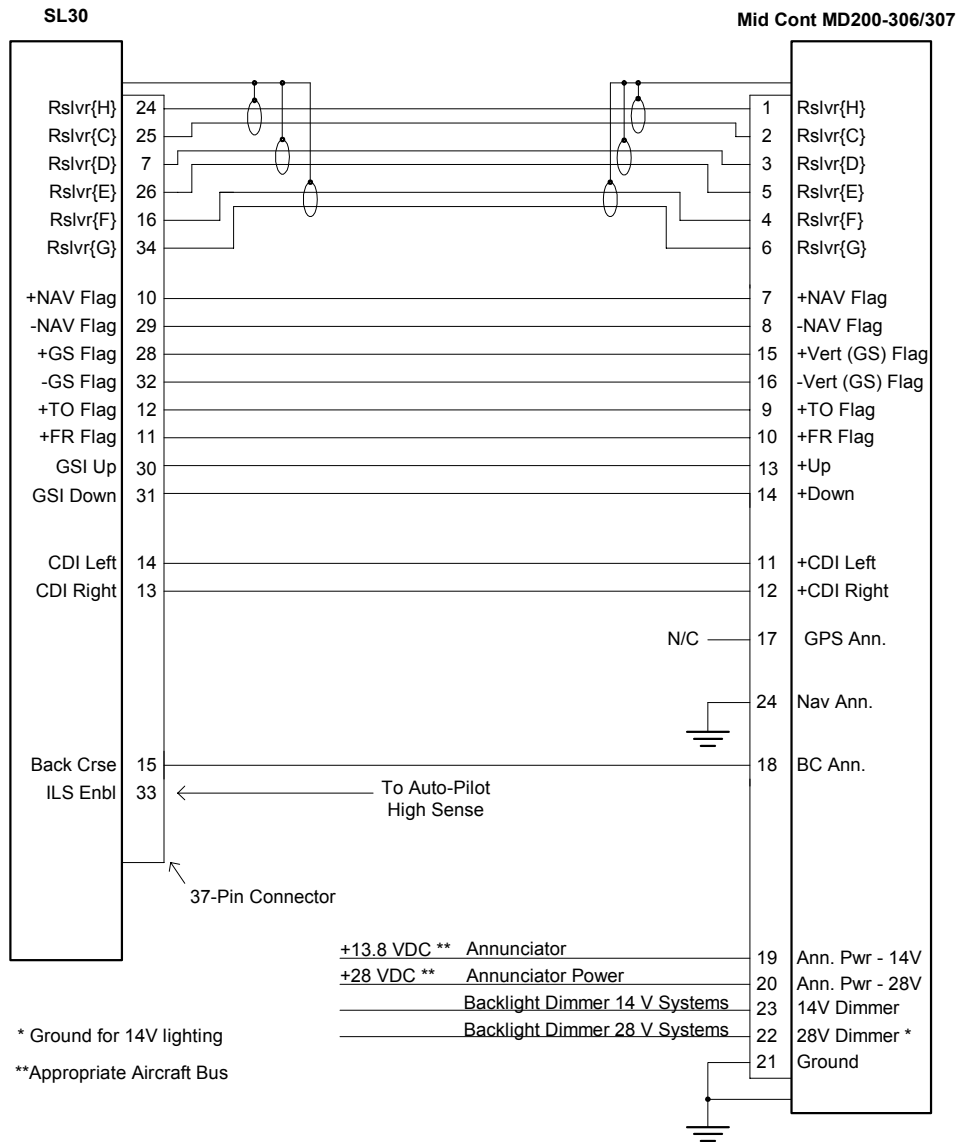

- NOTES:
1. Use shielded cable for resolver signals
 2. Connect cable shields to the mounting frame: pigtails < 1.25 inches
 3. Connect shields chassis ground at both ends of each shielded cable
 4. Reference the ACU installation manual if installing NAV/GPS source selector

Figure 12 - SL30 NAV to Mid-Cont MD200-306/307

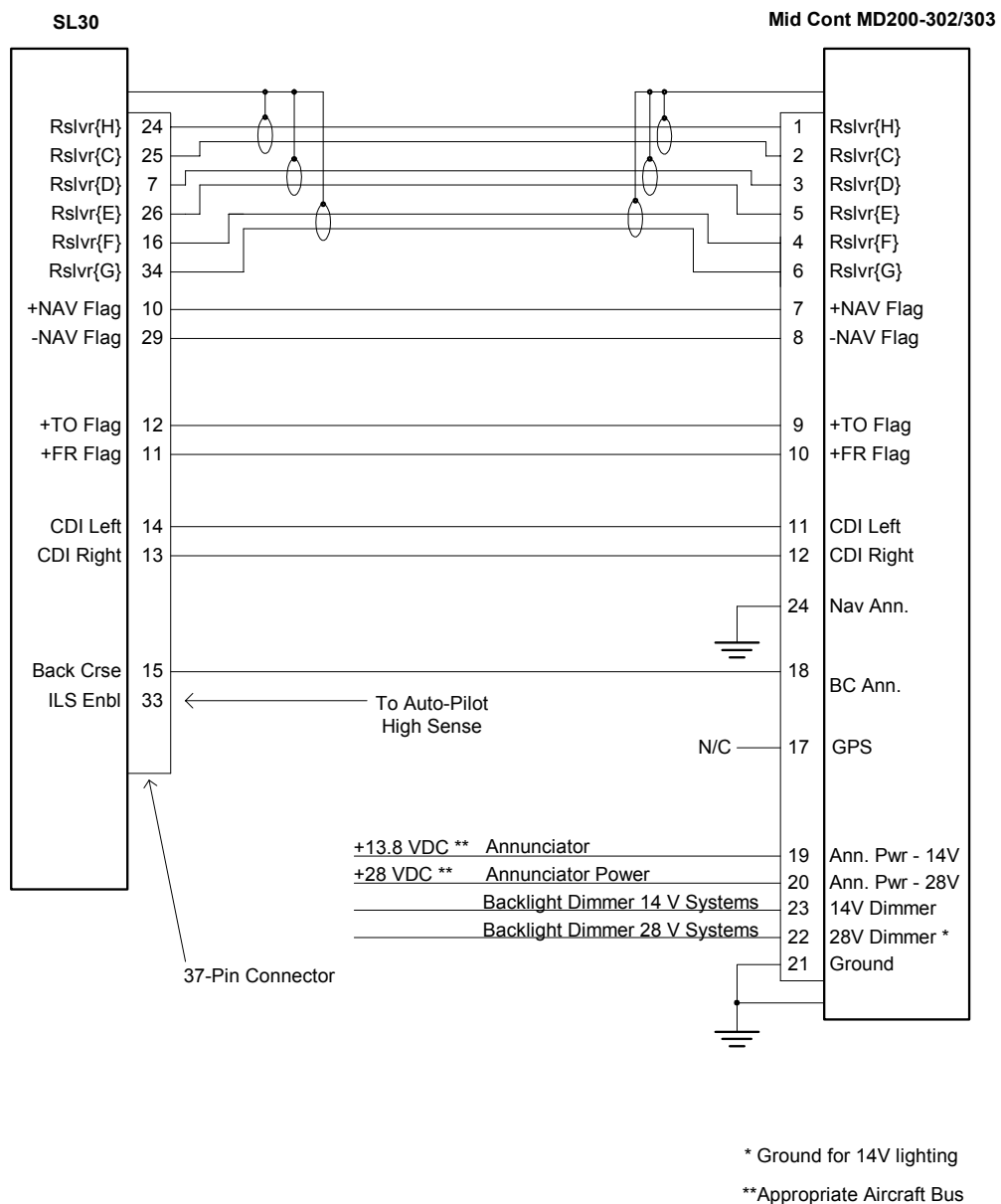

- NOTES:
1. Use shielded cable for resolver signals
 2. Connect cable shields to the mounting frame: pigtails < 1.25 inches
 3. Connect shields chassis ground at both ends of each shielded cable
 4. Reference the ACU installation manual if installing NAV/GPS source selector

Figure 13 - SL30 NAV to Mid-Cont MD200-302/303 Connections

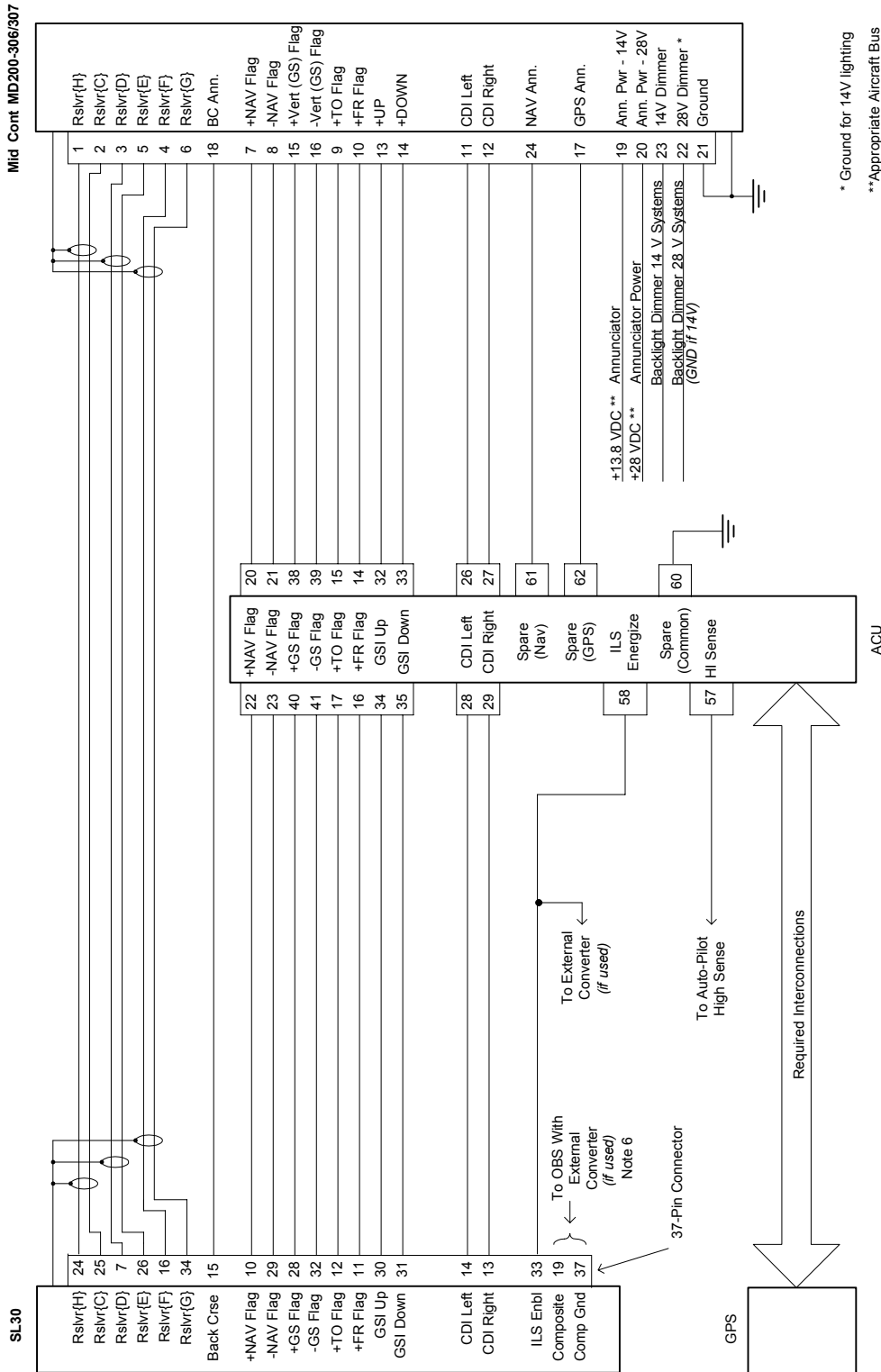

* Ground for 14V lighting
 **Appropriate Aircraft Bus

- NOTES:
1. Use shielded cable for Resolver signals
 2. Connect cable shields to the mounting frame: pigtailed < 1.25 inches
 3. Connect shields chassis ground at both ends of each shielded cable
 4. Reference the ACU installation manual if installing NAV/GPS source selector
 5. ILS and spare annunciator relays are only available in the Mod A ACU.
 6. Refer to Limitations on Using a Composite Signal paragraph in this chapter

Figure 14 - SL30 NAV and ACU to Mid-Cont MD200-306/307

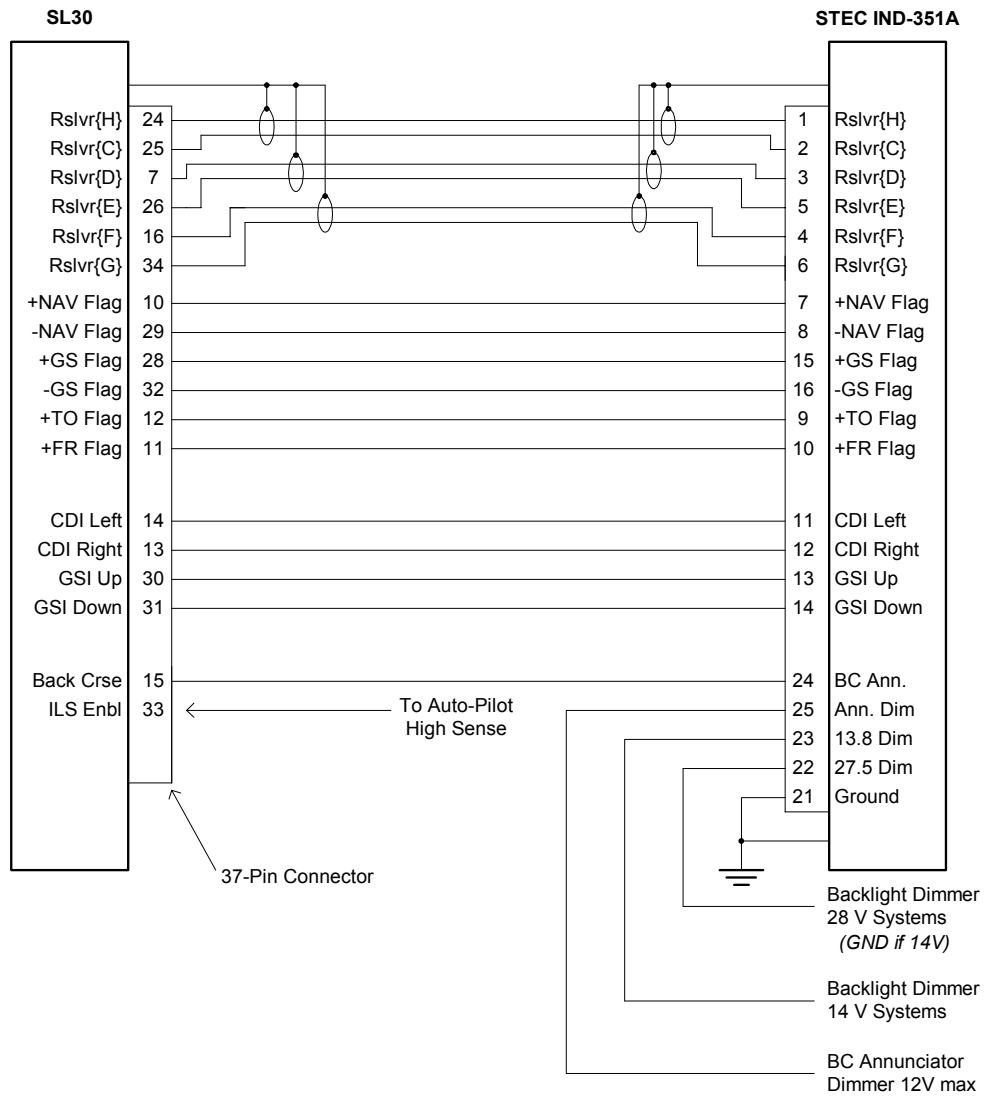

- NOTES:
1. Use shielded cable for Resolver signals
 2. Connect cable shields to the mounting frame: pigtails < 1.25 inches
 3. Connect shields chassis ground at both ends of each shielded cable
 4. Reference the ACU installation manual if installing NAV/GPS source selector.
 5. Installer should verify that the STEC IND-351A contains the proper annunciator, i.e., BC backcourse.

Figure 15 - SL30 NAV to STEC IND-351A Connections

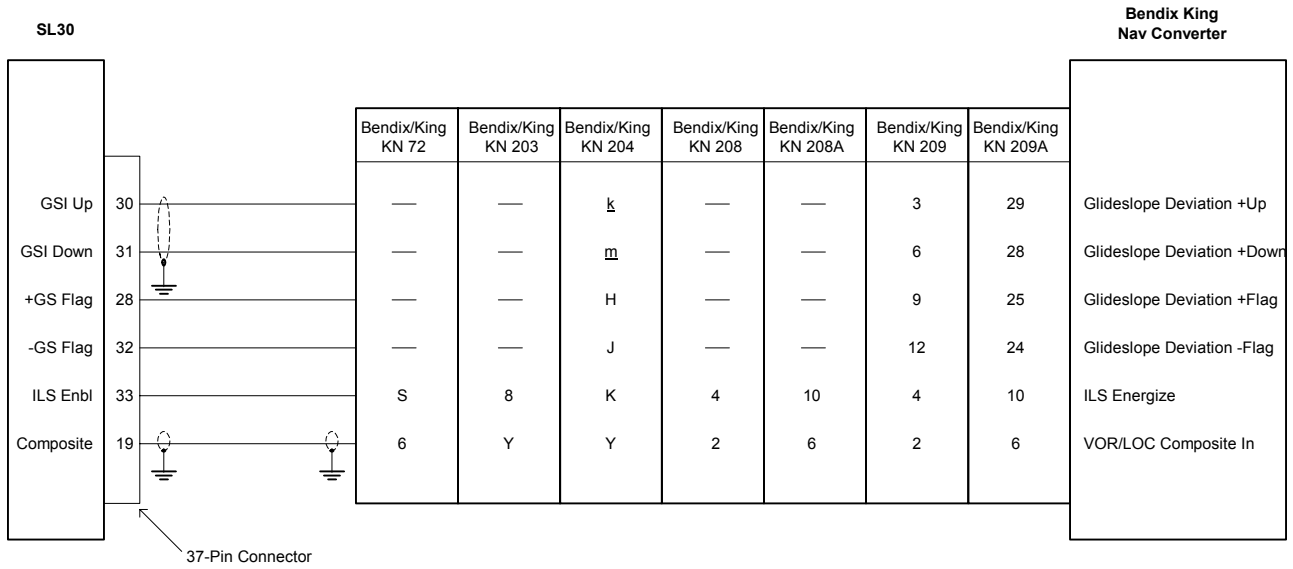

- NOTES: 1. Connect shield grounds to aircraft chassis with as short a conductor as practical.
 2. Refer to Limitations on Using Composite Signal paragraph in this chapter.
 3. Not all indicator connections are shown, only those interfacing to the SL30. Consult the appropriate installation manuals for complete wiring instructions.

Figure 16 - SL30 NAV to Bendix/King KN72/203/204/208/208A/209/209A Wiring

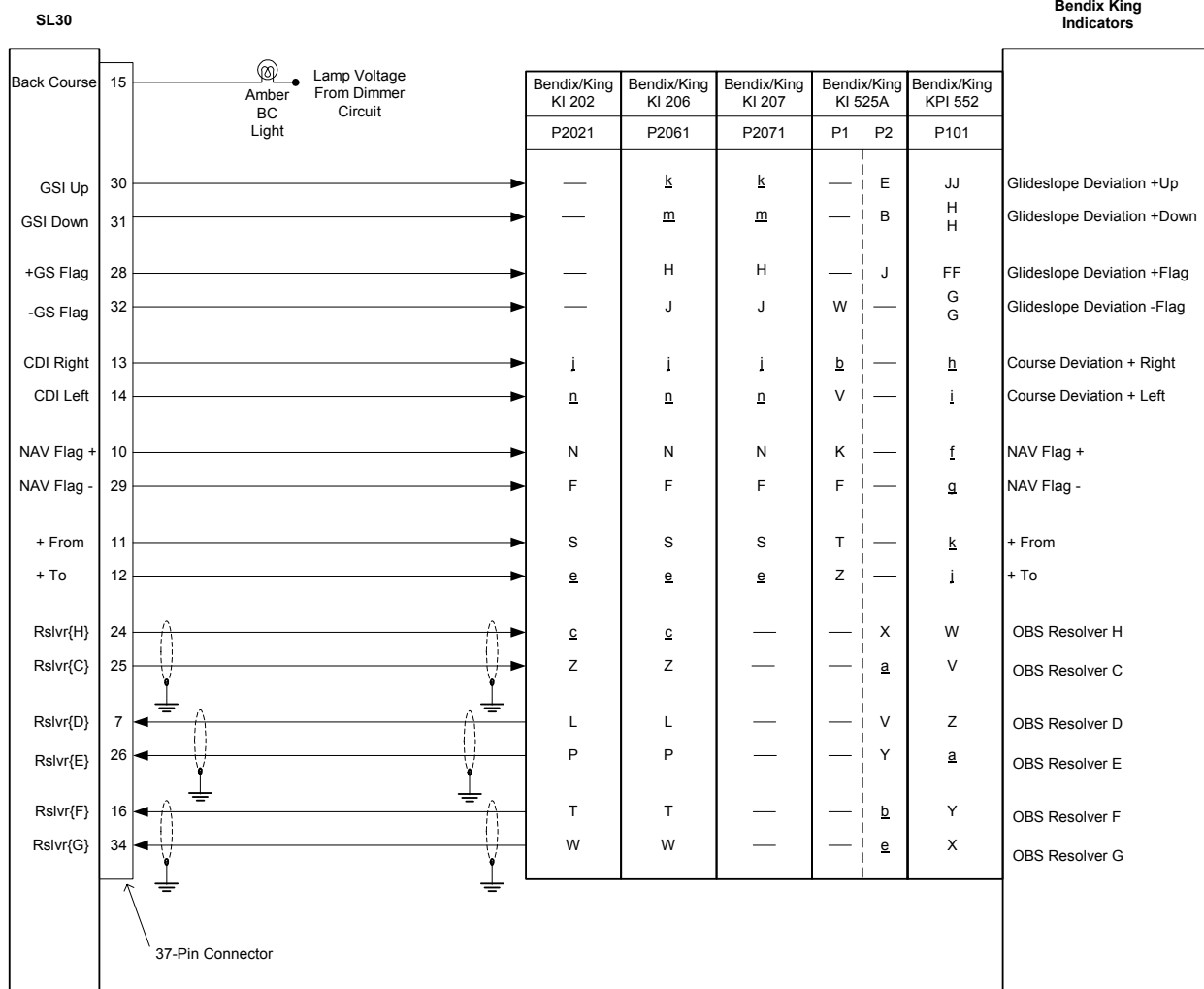

- NOTES:
1. Connect shield grounds to aircraft chassis with as short a conductor as practical.
 2. Not all indicator connections are shown, only those interfacing to the SL30. Consult the appropriate installation manuals for complete wiring instructions.

Figure 17 - SL30 NAV to Bendix/King KI202/206/525A/KPI552 Wiring

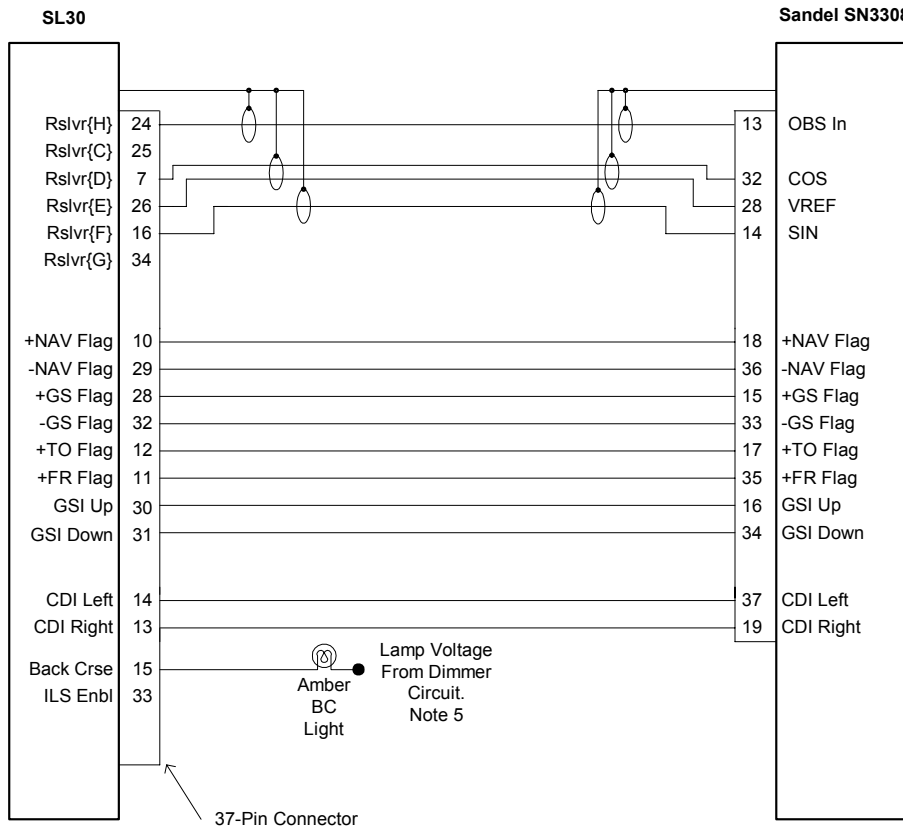

- NOTES:
1. Use shielded cable for resolver signals.
 2. Connect cable shields to the mounting frame; pigtails < 1.25 inches.
 3. Connect shields chassis ground at both ends of each shielded cable.
 4. Reference Sandel installation manual for switching NAV signals with GPS.
 5. BC annunciator may be implemented in future software revisions of the SN3308. Refer to Sandel installation manual.
 6. Not all indicator connections are shown, only those interfacing to the SL30. Consult the appropriate installation manuals for complete wiring instructions.

Figure 18 - SL30 NAV to Sandel Discrete Connections

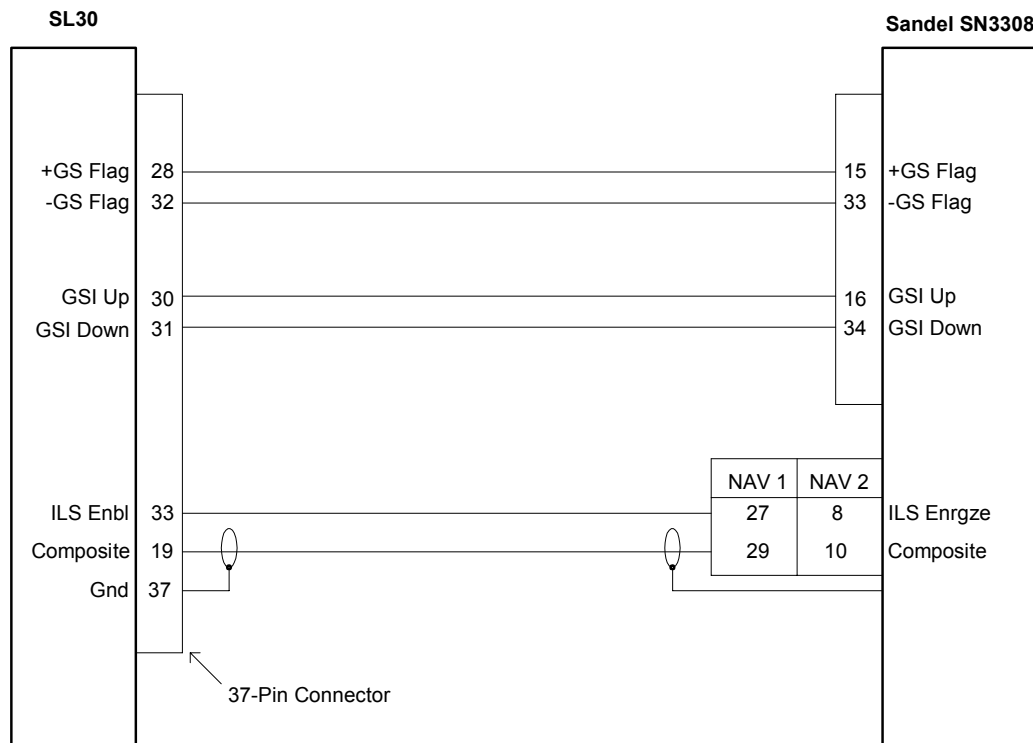

- NOTES:
1. Use shielded cable for resolver signals.
 2. Connect cable shields to the mounting frame: pigtails < 1.25 inches.
 3. Connect shields chassis ground at both ends of each shielded cable.
 4. Refer to Limitations on Using a Composite Signal paragraph in this chapter.
 5. Not all indicator connections are shown, only those interfacing to the SL30. Consult the appropriate installation manuals for complete wiring instructions.

Figure 19 - SL30 NAV to Sandel SN3308 Converter Connections

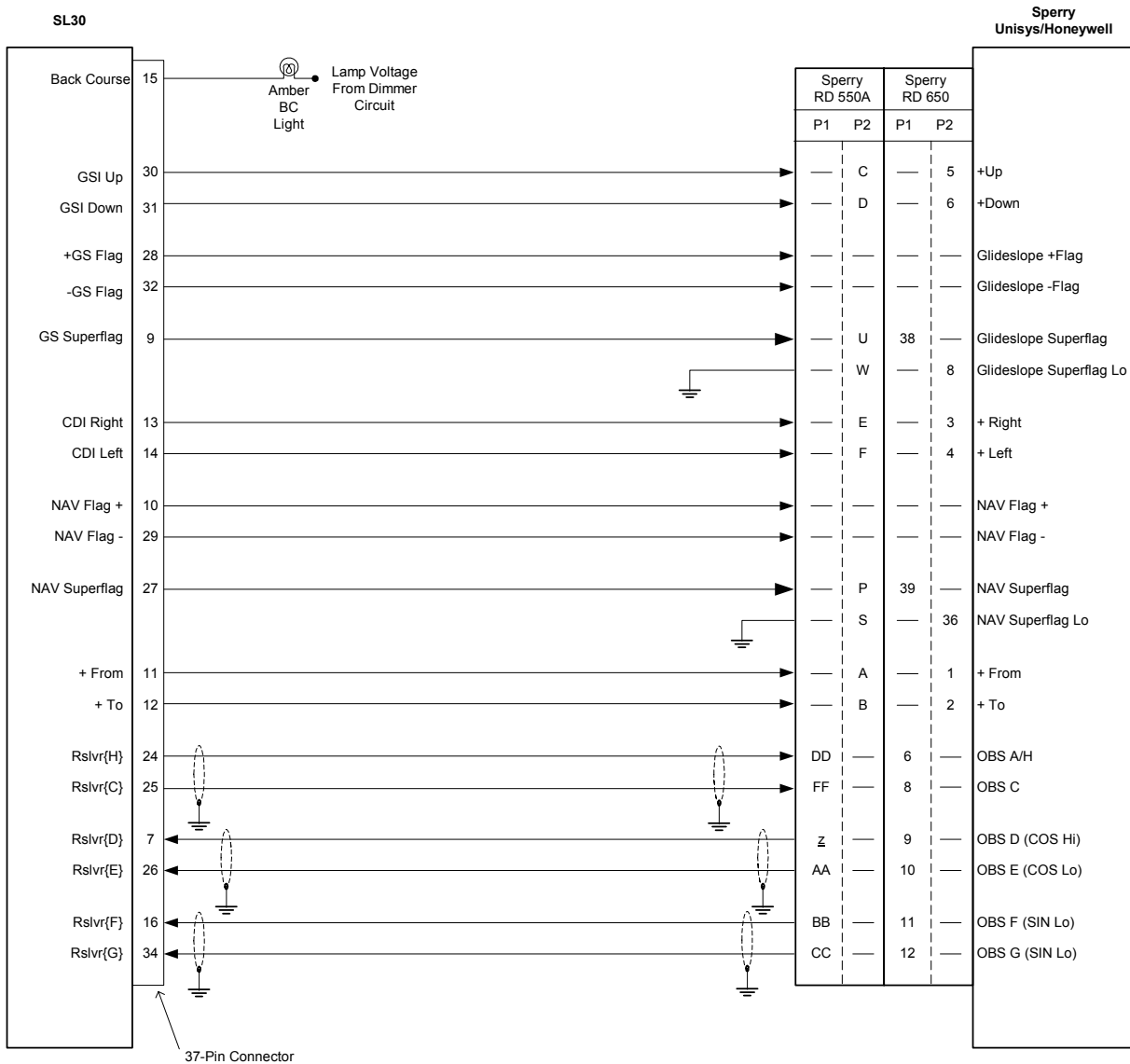

- NOTES:
1. Connect shield grounds to aircraft chassis with as short a conductor as practical.
 2. Not all indicator connections are shown, only those interfacing to the SL30. Consult the appropriate installation manuals for complete wiring instructions.

Figure 20 - SL30 to Sperry RD 550A and RD650 Wiring

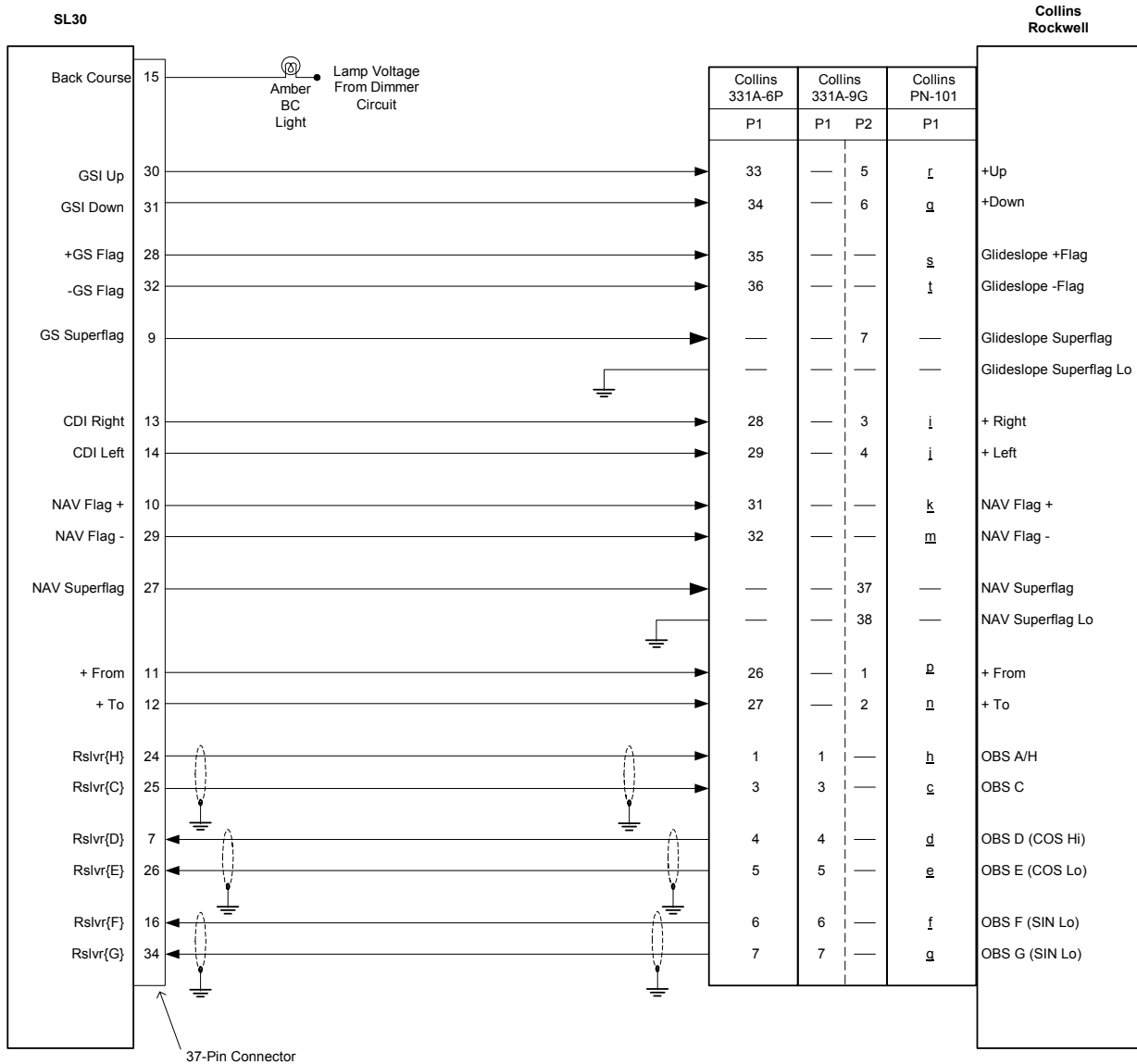

- NOTES: 1. Connect shield grounds to aircraft chassis with as short a conductor as practical.
 2. Not all indicator connections are shown, only those interfacing to the SL30. Consult the appropriate installation manuals for complete wiring instructions.

Figure 21 - SL30 to Collins 331A-6P, 331A-9G, and PN-101 Wiring

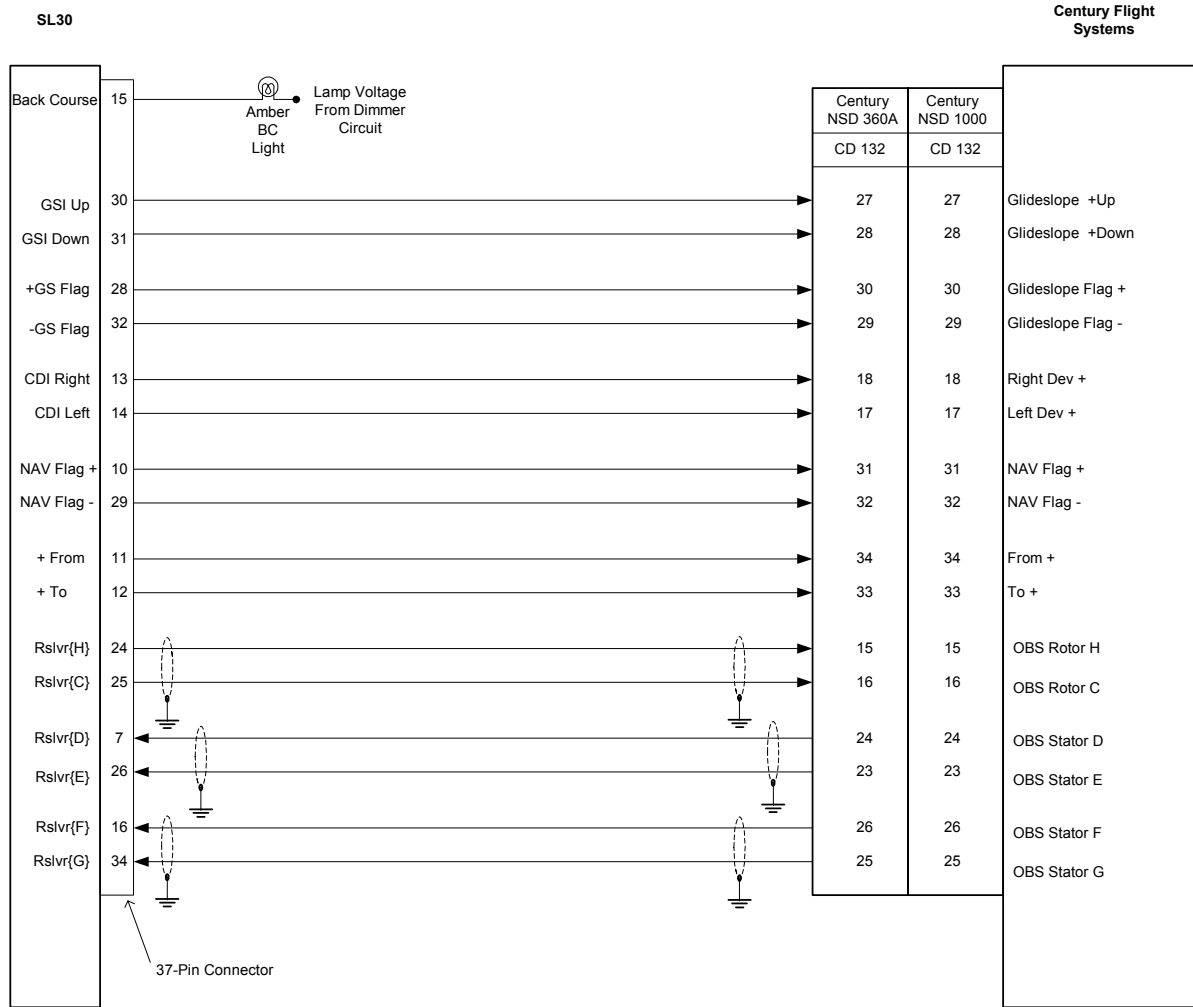

- NOTES:
1. Connect shield grounds to aircraft chassis with as short a conductor as practical.
 2. Not all indicator connections are shown, only those interfacing to the SL30. Consult the appropriate installation manuals for complete wiring instructions.

Figure 22 - SL30 to Century NSD 360A and NSD 1000 Wiring

LIMITATIONS ON USING A COMPOSITE SIGNAL

If an external converter is driven from the composite output in conjunction with a full function CDI/HSI with resolver, the indicator head type, when selected from the Setup Mode during the post installation checkout, should be RESOLVER. In this installation, the composite output will be disabled whenever the VOR monitor mode is active or back course localizer mode is enabled. This will cause the external converter to flag. If the CONVERTER option is selected from the Setup Mode as the indicator head type, neither of these two options is available to the pilot and the composite output should always be valid. The CONVERTER setup option should be used if an external converter is the only indicator interfaced to the SL30.

LIMITATIONS ON DISTANCE, SPEED, AND TIME INFORMATION

When Nav tuning is provided to the Apollo GX, the GX will output Distance, Speed, and Time (DST) information on the MapCom output. It is the installer's responsibility to ensure that this information is displayed in an acceptable fashion. For instance, in an installation where two Apollo SL30's are integrated in the system, it is not appropriate to display DST information on the SL30 that is not providing the tuning information. Apollo SL30 SW version 1.2, or later, provides the means for disabling the display of DST information.

POST INSTALLATION CHECKOUT

Once the unit is installed, complete the checkout procedure to verify proper operation. Refer to the User's Guide for operating instructions.

The steps that are not applicable to a particular installation may be skipped. A checkout log sheet is included on page 39 to fill out during the checkout procedure. Make a photocopy of the log sheet for ease of use if desired.

MOUNTING / WIRING CHECK

Verify that all cables are properly secured and shields are connected to the rear of the mounting frame. Check the movement of the aircraft controls to verify that there is no interference.

SETUP AND CHECKOUT

The SL30 has a built-in I/O test mode to simplify system setup and checkout. To operate the SL30 in the Setup Mode, hold down the ⇔ and SYS buttons while switching on the power. You must continue to hold the buttons in until a complete power up is done and SELECT CDI is displayed. To return to normal operation, switch the power off, and then back on.

In the Setup Mode, turn the large knob to view each function. In general, press the SEL button to activate selection, turn the small knob to view each option, and then press ENT to save the displayed value. Pressing SEL again will exit the option without saving any changes.

NAV Setup and Checkout

Indicator Head Type

Set up the SL30 for the indicator head type that it is connected to by using the Setup Mode as follows.

1. Rotate the large knob to the SELECT INDICATOR HEAD TYPE display.
2. Press SEL. The type will flash.
3. Turn the small knob to select desired option: NONE, RESOLVER, CONVERTER, or SERIAL. Selecting the RESOLVER option requires calibration, which is available by turning the large knob CW to the next display. The options are defined as follows:
 - NONE: No external resolver is supported. OBS mode allows the user to edit the OBS with concentric knobs. Serial OBS update messages are supported in this mode, but the unit will not flag if updates are discontinued or are not periodic.
 - RESOLVER: Auto-decodes resolver setting via six-wire resolver interface. Uses internal DSP to compute course information.
 - CONVERTER: Disables all internal OBS functions. Disables VOR monitor and BC selection. It allows use of conventional external converter via the composite output pin.
 - SERIAL: For use with serial Electronic Flight Instruments (EFIS) conforming to Garmin AT SL30 serial data specification. See Appendix E – Serial Interface Specifications. If serial OBS data is not received at a minimum 1 Hz rate, the NAV unit will flag.
Note: No serial test messages are sent in the Setup Mode while testing CDI and GSI flags.
4. Press ENT to accept and save the selected option.

Calibrating the Resolver Indicator Head Type

After selecting RESOLVER as the indicator head, it is necessary to calibrate the interface between the SL30 and the resolver. The SL30 cannot drive multiple resolvers at the same time. It is not recommended that external resolvers be switched through a relay or other means because the resolver must be calibrated to the radio as described in this procedure. If multiple resolvers are desired in the installation, the primary unit must be installed and calibrated as described here. The secondary unit should use the composite output.

1. After selecting RESOLVER as the indicator head type, turn the large knob to the PRESS SEL TO CALIBRATE RESOLVER display.
2. Press SEL.
3. Follow the directions on the SL30 display.
Note: The accuracy of the system is dependent on this calibration. Do not rush this step.
4. At the end of the setup, press ENT to store the results.
5. Cycle the power switch (enter the normal mode).
6. Tune a VOR station (any VOR frequency).
7. Press OBS button.
8. Verify that the OBS decodes properly from 0 to 360 degrees.

If the SL0 will not accept the calibration or advances to the next prompt when the ENT key is pressed, there may be a problem with the resolver interface.

Control Test

In the Setup Mode, turn the large knob to reach the CONTROL TEST page. This function tests the operation of the front panel controls on the SL30.

1. Press each button. The function name for each control will appear on the display after the button is pressed.
2. Turn the small knob. The numeric values on the right side of the display will change.

Display Test

In the Setup Mode, turn the large knob to reach the PRESS SEL TO TEST DISPLAY page.

1. Press SEL.
2. A series of display tests will be performed to test each LED. Observe the display for any missing LEDs.
3. When the test is completed, the display will return to normal mode.

Flags Test

The Flags test in Setup Mode sends an active signal for each selected flag so you can test the interface to the connected devices directly from the front panel while you are on the ground. The Flag tests include LOC (Localizer), BC (Back Course), FR (From), TO (TO), NAV (NAV), and GS (Glideslope). When a selection is in large text, an active signal is sent from the SL30.

1. In the Setup Mode, turn the large knob to the FLAGS TEST page.
2. Press SEL. The Localizer (LOC) selection will flash.
3. Turn the small knob to change the selection to large text. Check the attached indicator for the appropriate flag. Turn the small knob one click in either direction to change the selection back to small text.
4. Turn the large knob to the next flag type and turn the small knob to change it to large text. You can only select FR or TO as active, not both at the same time.
5. Ensure the flags are reset to all small text when you are finished testing.

CDI Test

This function tests for CDI function and allows for calibration between the SL30 and the attached CDI.

1. In the Setup Mode, turn the large knob to reach the CDI TEST page.
2. Press SEL to activate selection. The value will flash.
3. Rotate the small knob to change the value. The values "0-6" may be used to center the CDI needle.
4. Turn the small knob left or right to center the needle.
5. Press ENT when the needle is centered.
6. Turning the small knob left or right past a value of "6" will test the deflection of the CDI needle.

GSI Test

This function tests for GSI function and allows for calibration between the SL30 and the attached GSI.

1. In the Setup Mode, turn the large knob to reach the GSI TEST page.
2. Press SEL to activate selection. The value will flash.

3. Rotate the small knob to change the value. The values "0-6" may be used to center the GSI needle.
4. Turn the small knob left or right to center the needle.
5. Press ENT when the needle is centered.
6. Turning the small knob left or right past a value of "6" will test the deflection of the GSI needle.

DST Disable

The installer may need to disable the DST function when the unit is the second unit of a dual installation.

1. In the Setup Mode, turn the large knob to the ENABLE DST DATA DISPLAY page.
2. Press SEL. The selection will flash.
3. Turn the small knob to choose Yes or No.
4. Press ENT after making your selection.

VHF NAV Checkout

On the Ground

Check the VOR reception with ground equipment, operating VOT or VOR, and verify audio and Morse code ID functions (if possible). Tune a Localizer frequency and verify the CDI needle and NAV flag, and GSI needle GS flag.

Some VOR test equipment may not be compatible with the digital signal processing of the Apollo SL30 and will give erroneous results. Examples of equipment known to function properly are: IFR Nav 750 and Collins 479S-6.

Comm Setup and Checkout

Com RF Squelch

This value is used by the Comm function to control its squelch level. It is usually not necessary to adjust this value from its factory setting.

1. In the Setup Mode, turn the large knob to reach the COM RF SQUELCH page.
2. Press SEL to activate selection. The value will flash.
3. Rotate the small knob to change the level number. The range of the number is 25 to 100.

Note: *The larger the number the stronger the signal must be in order for the radio to break squelch. The factory default value is 56.*

4. Press ENT to save the value and exit the Setup Mode.

Microphone 1 and 2 Gain

Set the microphone gain for microphones 1 and 2 for values from 0 to 255.

1. In the Setup Mode, rotate the large knob to select MICROPHONE 1 (or 2) GAIN.
2. Press SEL to activate selection. The Mic 1 value will flash.
3. Turn the small knob to change the value.
4. Turn the large knob to the Mic 2 value. Turn the small knob to change the value.
5. Press ENT to accept and save the settings.

Note: *A value of 128 will work well for most headset units.*

Enable weather frequencies

This function determines whether the weather frequencies in common use in North America are displayed, or not.

1. In the Setup Mode, rotate the large knob to select **ENABLE WEATHER FREQUENCIES**.
2. Press **SEL** to activate selection. The Yes or No value will flash.
3. Turn the small knob to change the value.
4. Press **ENT** to accept and save the settings.

VHF Comm Checkout

Receiver / Transmitter Operation

Tune the unit to a local frequency and verify the receiver output produces a clear and understandable audio output. Verify the transmitter functions properly by contacting another station and getting a report of reliable communications. Check the remote flip/flop.

Antenna Check

The antenna V_{SWR} can be checked using an inline wattmeter in the antenna coax using frequencies near both ends of the band. The V_{SWR} should be $< 2:1$, and is not to exceed $3:1$. A V_{SWR} of $2:1$ will cause a drop in output power of approximately 12%, and $3:1$ causes approximately a 26% drop.

Sidetone Level Adjustment

The sidetone volume was preset at the factory to a typical audio level. The level can be adjusted using one of the built-in system functions. To adjust the sidetone level:

1. Press **SYS**, rotate the large knob to the **COM RADIO INFO:** page, and press **ENT**.
2. Rotate the large knob to the **SIDETONE LEVEL:** page.
3. Rotate the small knob to adjust the sidetone level. The sidetone level is displayed in a range of 1 to 100, and variable. The sidetone level can be adjusted during transmit.

Transmit Mic Selection

The Transmit Microphone page controls which microphone is permitted to transmit. Choose Mic 1, 2, or both. To select the Transmit Mic control:

1. Press the **SYS** button and rotate the large knob to **TRANSMIT MIC** page.
2. Rotate the small knob to select **MIC1**, **MIC2**, or **MIC1+MIC2**.
3. Select an appropriate frequency, key the transmitter, and talk into the microphones to check for the intended operation.

FINAL SYSTEM CHECK

The SL30 functions should be complete at this time. The final check includes verifying VOR and ILS operation. Start with the unit turned on and operating in the normal mode. Refer to the user's manual for operating instructions.

RS-232 Serial Interface Checks

The interfaces to other equipment, such as the GX series GPS, should be checked as follows:

1. Operate the SL30 and GX unit in normal mode.
2. Press the **Direct To** button on the GPS unit and select an airport. Press **ENT**.
3. Operate the SL30 in Comm mode. Press **SEL**.

4. Verify that the remote frequencies of the airport selected via the GPS unit are displayed on the SL30.

The interface to a DST data source (such as an Apollo GX or DB30) should be checked as follows:

1. Operate the SL30 in NAV mode and ensure the DME is operating with a valid signal.
2. Press the SEL button to bring up the NAV frequency recall lists.
3. Turn the large knob one click to the left (counterclockwise) to show the DST display prompt. If you do not see the Show DST Display, either the feature is disabled, or you are not receiving the data through the serial port.
4. Press ENT to replace the current NAV display with DST data. Verify that DST data is passed to the SL30.

To check the serial data output connections, verify the data from the SL30 can be displayed on the other units, such as the MX series multi-function display or the Apollo GX Nav Frequency display. For serial interface checks to a serial CDI consult the CDI installation checkout procedures.

Comm Flight Test Check

A flight test is recommended as a final installation verification. The performance may be verified by contacting a ground station at a range of at least 50nm while maintaining an appropriate altitude and over all normal flight attitudes. Performance should be checked using low, high, and mid band frequencies.

Check the VOR

1. Tune a local VOR station within 50 miles.
2. Verify the audio ident/voice quality.
3. Verify the Morse code decoder IDs the station (95% probability).
4. Fly to and from the station.
5. Verify NAV flag, TO/FR flag, and CDI are operational.
6. Record accuracy in System Log (see manual).

Check the ILS

1. Tune an ILS at the local airport.
2. Verify the audio ident/voice quality.
3. Verify the Morse code decoder IDs the station (95% probability).
4. Fly the approach.
5. Verify NAV flag, GS flag, and CDI and GSI are operational.
6. Verify BC annunciator.

APOLLO SL30 POST-INSTALLATION CHECKOUT LOG	Date: ___/___/___
	By: _____
CONFIGURATION INFORMATION:	
SL30 NAV/COMM 430-6040-3 ___ Mod ___ Serial # _____	
TEST MODE CHECKOUT AND SETUP:	
Avionics Outputs:	
<input type="checkbox"/> Resolver <input type="checkbox"/> Converter <input type="checkbox"/> Serial <input type="checkbox"/> None <input type="checkbox"/> Calibration (if Resolver) <input type="checkbox"/> Control Test <input type="checkbox"/> Display Test <input type="checkbox"/> NAV Valid flag <input type="checkbox"/> GS Valid flag <input type="checkbox"/> TO/FROM flag (OFF, TO, FROM) <input type="checkbox"/> External annunciator (BC) <input type="checkbox"/> CDI (left, mid, right) <input type="checkbox"/> GS (up, mid, down) <input type="checkbox"/> Enable Weather Freq Yes ___ No ___ <input type="checkbox"/> Enable DST Display Yes ___ No ___	
VHF NAV CHECKOUT:	
VOR reception with ground equipment <input type="checkbox"/> Audio and Morse code ID functions <input type="checkbox"/> Verify CDI NAV and GSI GS flags	
VHF COMM CHECKOUT:	
<input type="checkbox"/> Receiver / Transmitter operation <input type="checkbox"/> Sidetone level set / checked <input type="checkbox"/> Antenna check <input type="checkbox"/> Transmit Mic selection <input type="checkbox"/> Remote flip/flop input	
FINAL SYSTEM CHECK:	
<input type="checkbox"/> RS-232 inputs/outputs checked (Optional) <input type="checkbox"/> Comm Operation <input type="checkbox"/> VOR Check <input type="checkbox"/> Station ID <input type="checkbox"/> TO/FR <input type="checkbox"/> ILS Check <input type="checkbox"/> Left/Right (CDI) <input type="checkbox"/> Station ID <input type="checkbox"/> Valid Flag (NAV) <input type="checkbox"/> Valid Flags (NAV/GS) <input type="checkbox"/> Radial (To/From) <input type="checkbox"/> Left/Right (CDI) _____ Bearing Error <input type="checkbox"/> Up/Down (GSI) <input type="checkbox"/> Remote Flip/Flop input <input type="checkbox"/> BC Function (Annunciator)	
COMMENTS:	

INSTRUCTIONS FOR CONTINUED AIRWORTHINESS

Modification of an aircraft for the installation of the SL30 obligates the aircraft operator to include the maintenance information provided by this section in the operator's Aircraft Maintenance Manual and the operator's Aircraft Scheduled Maintenance Program.

1. Maintenance manual information (system description, operation, location, removal, testing, etc.) is contained within this document and any information should be copied to, and/or included with, the operator's airplane Maintenance Manual.
2. Line Replaceable Unit (LRU) part numbers and other necessary part numbers contained in the installation data package should be placed into the aircraft operator's airplane Illustrated Parts Catalog (IPC).
3. The specific wiring diagram information, along with the supplemental information described in the Installation Manual, pertaining to the installation of this unit, should be placed into the aircraft operator's airplane Wiring Diagram Manuals.
4. Scheduled Maintenance Program tasks to be added to the operator's maintenance program are found in Appendix B – Periodic Maintenance, of this installation manual.

SECTION 3 - SPECIFICATIONS

This section includes detailed electrical, physical, environmental and performance specifications for the Apollo SL30.

Note: Performance specifications are measured at ambient temperatures unless otherwise noted.

ELECTRICAL

Input voltage.....	10 VDC to 36 VDC, reverse polarity protected
Input current (VHF navigation input)	325 mA typical, 500 mA max at 13.75 VDC 170 mA typical, 350 mA max at 27.5 VDC
Input current (Comm input)	270 mA typical, 2 A max at 13.75 VDC, receive 130 mA typical, 900 mA max at 27.5 VDC, receive 2.1 A typical, 3.2 A max at 13.75 VDC, transmit 1.0 A typical, 1.4 A max at 27.5 VDC, transmit Note: receive max at full receive audio, transmit max at 90% modulation at 1000 Hz.
Input power (Comm input).....	3.7 watts typical, receive 28 watts typical, transmit
Internal fuses	Nav input: 3 amp fast blow, socketed on board Comm input : 7 amp fast blow, soldered in board
Memory backup.....	Internal flash memory

PHYSICAL

Height.....	1.30 inches (3.30 cm)
Width.....	6.25 inches (15.88 cm)
Depth.....	11.452 inches (29.09 cm) behind panel, including mounting frame and connectors
Weight (without mounting frame).....	2.25 lb. (1.02 kg)

ENVIRONMENTAL

The Apollo SL30 is designed and tested to meet appropriate categories of RTCA/DO-160C and RTCA/DO-160D. The Environmental Qualification Form is included in Appendix C.

Operating temperature.....	-20°C to +55°C
Storage temperature.....	-55°C to +85°C
Temperature variation	2°C per minute
Humidity.....	95% at 65°C for 48 hours
Maximum altitude	25,000 feet
Cooling.....	Not required

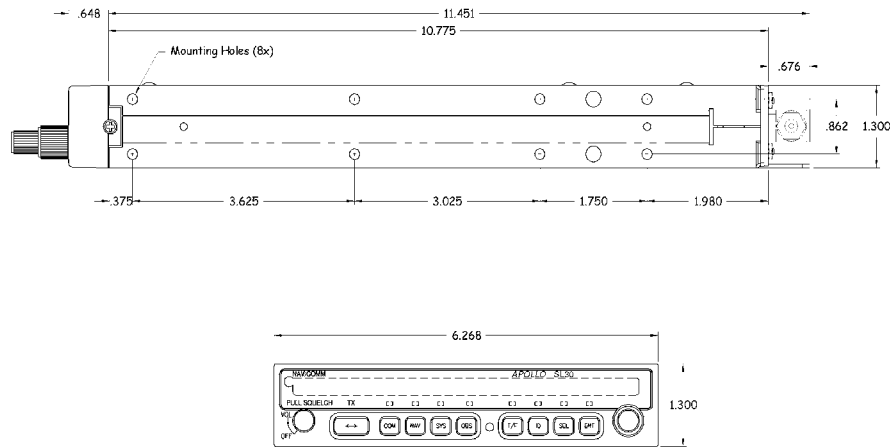

Figure 23 - Unit Dimensions

AVIONICS OUTPUTS

CDI L/R deviation	± 150 mV full scale, will drive up to 200-ohm load
TO/OFF/FROM flag	± 250 mV, TO/FROM indication, will drive up to 200-ohm load
Nav valid flag	+300 mV for valid indication, will drive up to 200-ohm load
Nav superflag	Vin - 2 volts minimum for valid, source capability of 400 mA
GSI U/D deviation	± 150 mV full scale, will drive up to 200-ohm load
GS valid flag	+300 mV for valid indication, will drive up to 200-ohm load
GS superflag	Vin - 2 volts minimum for valid, source capability of 400 mA
Annunciators	Open collector outputs capable of sinking up to 400 mA for turning on annunciator lamps <ul style="list-style-type: none"> • BC • Localizer
Power Control	Open collector output capable of sinking up to 50 mA. Active when unit is powered up.

NAV RECEIVER PERFORMANCE

VOR

TSO/JTSO compliance.....	TSO-C40c (DO-196)/JTSO 2C40c
Applicable documents	RTCA DO-196
Operational class	N/A
Accuracy category.....	B { -46°C to + 55°C }
Frequency range	108.00 to 117.95 MHz in 50 kHz increments
Frequency tolerance	0.0008%
Cross modulation products.....	At least 60 dB down
Receiver sensitivity	108 MHz –115 dBm typical 117 MHz –117 dBm typical
Course accuracy	RTCA DO-196 two sigma limit: 3° SL30 performance: less than 0.5° typical
Audio output.....	With a 1 kHz tone 30% modulation at least 100 mW output into 500 ohm loads
Ident/voice.....	With 100 mV input, 30% modulation at 1020 Hz, the ident/voice tone ratio shall not be less than 15 dB
Audio response.....	Less than 6 dB variation from 350 Hz to 2500 Hz

LOCALIZER

TSO compliance.....	TSO-C36e (DO-195)/JTSO C36e
Applicable documents	RTCA DO-195
Operational class	A { manual landing systems }
Accuracy category.....	B { -46°C to + 55°C }
Frequency range	108.00 to 111.95 MHz
Frequency tolerance	0.0008%
Cross modulation products.....	At least 60 dB down
Receiver sensitivity	-115 dBm typical
Centering error	RTCA DO-195 two sigma limit: 6.6% of full scale SL30 performance: less than 1.0% typical (1.5 mV)
Audio output.....	With a 1 kHz tone 30% modulation at least 100 mW output into 500 ohm loads
Ident/voice.....	With 100 mV input, 30% modulation at 1020 Hz, the ident/voice tone ratio shall not be less than 15 dB

Audio response Less than 6 dB variation from 350 Hz to 2500 Hz

GLIDESLOPE

TSO compliance..... TSO-C34e (DO-192)/JTSO C34e
Applicable documents..... RTCA DO-192
Operational class..... N/A
Accuracy category B { -46°C to + 55°C }
Frequency range..... 329.150 to 335.00 MHz
Frequency tolerance 0.0008%
Cross modulation products At least 60 dB down
Receiver sensitivity..... -95 dBm typical
Centering error RTCA DO-195 two sigma limit: 6.7% of full scale
SL30 performance: less than 2.0% typical (3.0 mV)

OBS RESOLVER

TSO compliance..... TSO-C40c (DO-196)/JTSO 2C40c
Applicable documents..... RTCA DO-196
Operational class..... N/A
Accuracy category B { -46°C to + 55°C }
Output signal..... 300 Hz ± 2 Hz (rounded square wave)
Output voltage (automatically
adjusted during calibration)..... 5 Vpp to 10 Vpp
Input voltage max (calibrated)..... 5 Vpp (when OBS is set to maximum)
Resolver voltage gain (loss)..... 1:1 maximum, 2:1 minimum
Output loading at max voltage..... 100 ohms impedance
Accuracy/Resolution..... 0.25° rounded to 1° steps

COMPOSITE OUTPUT

VOR Mode

Band pass frequency 0 Hz to 15 kHz
Variation over frequency range Less than 2 dB
Output signal voltage 0.500 V_{RMS}
Output loading 1,000 ohms (max)

LOC Mode

Band pass frequency 0 Hz to 15 kHz
Variation over frequency range Less than 2 dB

Output signal voltage	0.390 V _{RMS} (0.275 V _{RMS} @ 90 Hz, 0.275 V _{RMS} @ 150 Hz)
Output loading.....	1,000 ohms (max)
ILS energize signal.....	Sinks up to 400 mA (max)

COMM RECEIVER PERFORMANCE

Class	D
Frequency range	118.000 to 136.975 MHz, 760 channels
Sensitivity.....	1 μV (2 μV hard) for 6 dB S+N/N with 30% modulation at 1000 Hz
Selectivity.....	< 6dB variation at ± 7 kHz, > 60 dB at ± 22 kHz
Speaker audio output level.....	12 watts into 4 Ω, 8 watts into 8 Ω
Headphone audio output level.....	280 mW into 100 Ω, 120 mW into 500 Ω
Distortion.....	< 5% at rated output at 1000 Hz
AGC characteristics.....	< 3db variation in audio output from 5 μV to 100 mV input, 15% to 90% modulation
Squelch control.....	Automatic squelch with manual override

COMM TRANSMITTER PERFORMANCE

Class	4
Output power.....	8 watts minimum carrier at >12 VDC input, 6 watts minimum at 10 VDC input (transmit is locked out below 9 volts input)
Frequency range	118.000 to 136.975 MHz, 760 channels
Frequency tolerance	±15 ppm from -20°C to +70°C
Microphone input	Two inputs, standard carbon or dynamic mic with integrated preamp providing minimum 70 mv rms into 1000 Ω load
Modulation capability	85% with 100 mv to 1000 mv rms microphone input at 1000 Hz
Audio frequency distortion.....	< 10% at 85% modulation at 350 to 2500 Hz
Audio frequency response.....	< 4 dB variation with 350 to 2500 Hz, 85% modulation
Carrier noise level	> 35 dB down
Sidetone output.....	up to 280 mW into 100 Ω, 120 mW into 500 Ω
Duty cycle	100%

Stuck mic time-out.....35-second time-out, reverts to receive

INTERCOM PERFORMANCE

Microphone input.....Two inputs, standard carbon or dynamic mic with integrated preamp providing minimum 70 mv rms into 1000 Ω load

Headphone audio output level280 mW into 100 Ω , 120 mW into 500 Ω

AGC characteristicsoutput varies < 3 dB with input of 100 mv rms to 1000 mv rms

CONTROL INPUTS

Transmit keyInput pulled low to ground to enable the transmitter

Intercom select.....Input pulled low to ground to enable the intercom function

Flip/Flop.....Remote Comm flip/flop input, connect to a momentary button to ground for remote flip/flop operation.

ANTENNA REQUIREMENTS

COMM ANTENNA

The Apollo SL30 requires a VHF Comm antenna meeting the following specifications:

- Standard 50 Ω vertically polarized antenna with a VSWR < 2.5:1.

NAV ANTENNA

The Apollo SL30 requires a VHF NAV antenna meeting the following specifications:

- Standard 50 Ω horizontally polarized antenna with a VSWR < 3:1
- Capable of receiving VOR/LOC/GS (Recommend Comant Industries P/N CI 157P)
- 108.00 – 117.95 MHz (VOR/LOC)
- 328.60 – 335.4 MHz (GS)

Note: Multiple NAV antennas may be used with an RF signal splitter/combiner, part number 115-0007, at the radio. Refer to page 16.

SERIAL INTERFACE

RS-232..... Defined in Appendix E - Serial Interface Specifications

REAR CONNECTOR PINOUT

The SL30 includes two rear panel connectors, a 15-pin for the Comm interface connections and a 37-pin for the rear panel connections. The pinout for the connectors is listed in the following tables.

Table 2 - Comm Interface Connector Pinout			
Pin #	I/O	Connection	Function
1	I	Power +	Main DC power input
2	I	Reserved	Do not connect
3	O	Reserved	Do not connect
4	I	TxKey	Transmit enable key, pulled low to transmit
5	--	NC	Do not connect
6	O	Speaker	Speaker terminal output
7	I	Mic ground	Microphone input ground connection
8	I	Mic 1	Microphone input #1
9	I	Power ground	Main power ground input
10	I	Reserved	Do not connect
11	O	Reserved	Do not connect
12	I	Intercom select	Intercom function select, pulled low to turn on the intercom function
13	O	Audio ground	Speaker and headphone ground connection
14	O	Headphone	Headphone terminal output
15	I	Mic 2	Microphone input #2

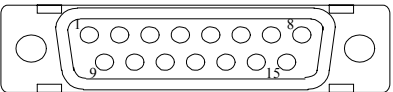

Viewed from rear of unit

Table 3 - Rear Panel Connector Pinout

Pin #	I/O	Connection	Function
1	I	Power +	Main DC power input
2	I	Power ground	Main power ground input
3	O	Serial ground	RS-232 signal ground
4	I	RxD1	RS-232 channel 1 serial data input
5	O	TxD1	RS-232 channel 1 serial data output
6	I	Test Input	Reserved for manufacturers test
7	I	OBS_D {S1}	Resolver input pin from Channel D (COS)
8	I	Flip/Flop	Remote NAV/Comm frequency flip/flop input
9	O	GSI superflag	GSI high level valid flag output
10	O	Nav + valid	Nav low level valid flag output
11	O	+ FROM	+ From flag output
12	O	+ TO	+ To flag output
13	O	CDI + Right	CDI + Right output
14	O	CDI + Left	CDI + Left output
15	O	Back course	Active low output when reverse sensing is engaged
16	O	OBS_F {S4}	Resolver input pin from Channel F (SIN)
17	--	Reserved	Do not connect
18	--	Reserved	Do not connect
19	O	Composite Output	VOR/LOC composite signal
20	O	Audio ground	Audio signal ground pin
21	O	Reserved	Do not connect
22	O	Reserved	Do not connect
23	O	NAV Audio Output	Low level audio output
24	O	OBS_H {R HI}	Resolver output pin to channel H
25	O	OBS_C {R LO}	Resolver return signals C
26	I	OBS_E {S3}	Resolver return signals E
27	O	Nav superflag	Nav high level superflag output
28	O	GSI + valid	GSI low level valid flag output
29	O	NAV - valid	Signal ground for NAV valid flag
30	O	GSI + Up	GSI +Up output
31	O	GSI + Down	GSI +Down output
32	O	GSI - Valid	Signal ground for GS valid flag
33	O	ILS energize	Active low output when a localizer frequency is tuned
34	O	OBS_G {S2}	Resolver return signals G
35	--	Reserved	Do not connect
36	O	Power control	Power control output sinks up to 50 mA when unit is on
37	O	Ground (comp)	VOR/LOC composite ground return

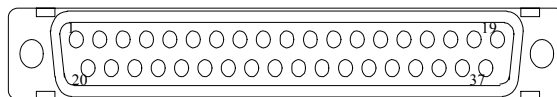

Viewed from rear of unit

SECTION 4 - LIMITATIONS

INSTALLATION

For minimum equipment and connections required for VFR or IFR installations, refer to the Minimum System Configuration section on page 9.

Installations of the SL30 Nav/Comm functions are to be made in accordance with AC 20-67B, TSO-C37d, TSO-C38d, TSO-C128, TSO-C34e, TSO-C36e, TSO-C40c, TSO-C66c, FAR Part 21-Subpart O, FAR Part 21-Subpart K, or other appropriate FAA approved (or JAA approved) guidelines.

When Nav tuning is provided to an Apollo GX, the GX will output Distance, Speed, and Time (DST) information on the MapCom output. It is the installer's responsibility to ensure that this information is displayed in an acceptable fashion on the Apollo SL30. For instance, in an installation where two Apollo SL30's are integrated in the system, it is not appropriate to display DST information on the SL30 that is not providing the tuning information. Apollo SL30 SW version 1.2, or later, provides the means for disabling the display of DST information.

Note: *It is recommended that aircraft be equipped with at least two NAV receivers and two Comm transceivers for IFR use. If this practice is followed, the loss of NAV function, Comm function or both will not result in the loss of either of the NAV or Comm functions at the aircraft level. This will support a System Safety Assessment of minor for IFR operations. Refer to AC 23.1309-1C.*

The SL30 is qualified for helicopter installation only when the correct mounting hardware and SL configurations are used. Mount Tube P/N 310-5197-00 and Connector Mounting Plate P/N 310-5192-01 (or later FAA-approved revisions) are required for helicopter installations and recommended for all installations. SL30 P/N 430-6040-303 (or later FAA-approved revision) or SL30 units upgraded with Mod V should be used in helicopter installations.

COMPUTATION RATES

The tuned active frequency is computed 10 times per second. If the VOR monitor function is activated, 20% of each second is allocated to the monitored frequency, slightly decreasing the active to frequency computation rate. It is important to note that the monitored frequency is only updated once per second. When interfacing the monitored channel to an EFIS or RMI, it should only be used as a crossing radial. While the monitored frequency is suitable for en route course navigation, it may not be suitable for primary course navigation on an approach due to its one-second update rate.

OPERATIONAL

An aircraft radio station license may be required with the SL30 for transmitting.

NOTES

APPENDIX A - TROUBLESHOOTING

This appendix provides information to assist troubleshooting if problems occur after completing the installation. Use Table 4 to assist in troubleshooting.

Table 4 - Troubleshooting Guide		
Problem	Cause	Solution
The SL30 does not power on.	The unit is not getting power.	Check power connections, breakers, and main avionics switch.
No NAV audio	Output disabled or set to a low level.	Check System page; NAV Options; NAV Audio Level.
NAV audio in Comm	Mixed with Comm feature.	Check System page; NAV Options; Mix NAV Audio With Com.
The SL30 does not transmit.	The TxKey input is not being pulled low. A weather channel is selected. No power to the Comm. The input voltage is too low.	Check the TxKey (mic key) input, pulled low for transmit. Select a different frequency, the unit will not transmit on a weather channel. Make sure power input is connected to the Comm 15 pin connector. Increase input supply voltage to > 9 volts DC.
The sidetone level is too low or too high.	Wrong type of headsets, or level needs adjustment.	See the Sidetone Level Adjustment on page 37.
The intercom doesn't function.	Control input not connected. Active frequency signal present. No voice activation, or have to talk too loud.	The intercom select input must be pulled to ground to turn on the intercom function. Change the active frequency. The active frequency has priority. Change the intercom level threshold using the setup function described in the user's manual.
Unit won't communicate via RS-232	Improper setup on the remote device. Device not compatible, or improper connection.	Consult the configuration of the other device. Verify SL30 Rx is connected to remote device Tx and SL30 Tx is connected to remote device Rx.
Resolver won't calibrate.	Incompatible resolver or improper connection.	Check the resolver specifications and wiring.
Unit won't communicate via RS-232	Improper setup on remote device, device not compatible, or improper connection.	Consult configuration of other device. Verify Rx is connected to Tx and Tx is connected to Rx of the device.

CONTACTING THE FACTORY FOR ASSISTANCE

If the Apollo SL30 unit fails to operate despite troubleshooting efforts, contact the Garmin AT factory for assistance.

Garmin AT, Inc.
2345 Turner Rd. SE
Salem, Oregon 97302
USA

Phone 503.581.8101 or 800.525.6726

Be prepared with the following information about the installation:

- Installation configuration (accessories, antenna, ...)
- Model number, part number with mod levels, and serial number
- Software versions
- Description of problem
- Efforts made to isolate the problem
- other installed avionics

APPENDIX B - PERIODIC MAINTENANCE

The SL30 unit is designed to not require any regular general maintenance except as included in this section.

VOR CHECKS

Even though the SL30 is designed to utilize the most state-of-the-art DSP technology and maintain a very high accuracy and repeatability record, it still must undergo the VOR accuracy checks required for IFR flight. Refer to CFR 14 paragraph 91.171. Every 30 days verify the limits of the permissible indicated bearing error.

The last VOR check information may be entered into the SL30 via the system mode VOR CHECK. See the operator's manual for details.

EQUIPMENT CALIBRATION

The SL30 design requires very few adjustments or calibration to be made. In fact, there are **no** internal manual adjustments.

REFERENCE OSCILLATOR (COMM ONLY)

The reference oscillator frequency should be checked approximately every 3 to 5 years to ensure the units transmit frequency is within allowable tolerance.

The oscillator frequency can be checked by connecting the transmitter output through an appropriate load to a calibrated frequency counter. The transmit frequency should be within 15ppm of the selected channel frequency. Contact the Garmin AT factory for instructions on adjusting the frequency if required.

CLEANING THE FRONT PANEL

The front bezel, keypad, and display can be cleaned with a soft cotton cloth dampened with clean water. **DO NOT** use any chemical cleaning agents. Care should be taken to avoid scratching the surface of the display.

NOTES

APPENDIX C - ENVIRONMENTAL QUALIFICATIONS

The Apollo SL30 Comm module has been tested to the following environmental categories per procedures defined in RTCA/DO-160C.

Environmental Qualification Form		
Model: Part No: TSO No:	SL30 Comm portion 430-6040-3XX TSO-C37d, TSO-C38d, & TSO-C128	Manufacturer: Garmin AT, Inc. 2345 Turner Road SE Salem, Oregon 97302
Conditions	DO-106C Section	Description of Conducted Tests
Temperature and Altitude	4.0	Equipment tested to Category C1
In-flight Loss of Cooling	4.5.4	No cooling required
Altitude	4.6.3	Equipment tested to 35,000 feet
Temperature Variation	5.0	Equipment tested to Category C, 2°C/min
Humidity	6.0	Equipment tested to Category A, standard humidity environment
Operational Shocks and Crash Safety	7	Equipment tested for both operational and crash safety shocks. (Equipment operated normally after the crash safety shocks.)
Vibration	8.0	Equipment tested without shock mounts to Categories B, M, and N (tested to Robust Helicopter Vibration per DO-160D)
Explosion Proofness	9.0	Equipment identified as Category X, no test required
Waterproofness	10.0	Equipment identified as Category X, no test required
Fluids Susceptibility	11.0	Equipment identified as Category X, no test required
Sand and Dust	12.0	Equipment identified as Category X, no test required
Fungus Resistance	13.0	Equipment identified as Category X, no test required
Salt Spray	14.0	Equipment identified as Category X, no test required
Magnetic Effect	15.0	Equipment is Class Z
Power Input	16.0	Equipment tested to Categories A & B
Voltage Spike	17.0	Equipment tested to Category A
Audio Frequency Conducted Susceptibility - Power Inputs	18.0	Equipment tested to Categories A & B
Induced Signal Susceptibility	19.0	Equipment tested to Category Z
Radio Frequency Susceptibility (Radiated and Conducted)	20	Equipment tested to Category V for conducted, Category U for radiated
Emission of Radio Frequency Energy	21	Equipment tested to Category Z
Lightning Induced Transient Susceptibility	22.0	Equipment tested to Categories A3 and B2
Lightning Direct Effects	23.0	Equipment identified as Category X, no test required
Icing	24.0	Equipment identified as Category X, no test required
Remarks:		

The Apollo SL30 Nav module has been tested to the following environmental categories per procedures defined in RTCA/DO-160D.

Environmental Qualification Form		
Model: Part No: TSO No:	SL30 NAV portion 430-6040-3XX TSO-C34e, TSO-C36e, TSO-C40c, & TSO-C66c	Manufacturer: Garmin AT, Inc. 2345 Turner Road SE Salem, Oregon 97302
Conditions	DO-160D Section	Description of Conducted Tests
Temperature and Altitude	4.0	Equipment tested to Category B1 with Operating temp: -20°C to +55°C Short time hi temp: to +70°C Ground survival temp: -55°C to +85°C
In-flight Loss of Cooling	4.5.4	No cooling required
Altitude	4.6.1	Equipment tested to 25,000 feet
Temperature Variation	5.0	Equipment tested to Category C, 2°C/min
Humidity	6.0	Equipment tested to Category A, standard humidity environment
Operational Shocks and Crash Safety	7	Equipment tested for both operational and crash safety shocks to Category B. (Equipment operated normally after the crash safety shocks.)
Vibration	8.0	Standard vibration category S (curves M and B) Robust Helicopter Vibration Category U (curves F and F1)
Explosion Proofness	9.0	Equipment identified as Category X, no test required
Waterproofness	10.0	Equipment identified as Category X, no test required
Fluids Susceptibility	11.0	Equipment identified as Category X, no test required
Sand and Dust	12.0	Equipment identified as Category X, no test required
Fungus Resistance	13.0	Equipment identified as Category X, no test required
Salt Spray	14.0	Equipment identified as Category X, no test required
Magnetic Effect	15.0	Equipment is Class Z, <0.3 meters
Power Input	16.0	Equipment tested to Categories A & B
Voltage Spike	17.0	Equipment tested to Category A
Audio Frequency Conducted Susceptibility - Power Inputs	18.0	Equipment tested to Categories A & B
Induced Signal Susceptibility	19.0	Equipment tested to Category Z
Radio Frequency Susceptibility (Radiated and Conducted)	20	Equipment tested to Category V
Emission of Radio Frequency Energy	21	Equipment tested to Category M
Lightning Induced Transient Susceptibility	22.0	Equipment tested to - Categories A3 and B2
Lightning Direct Effects	23.0	Equipment identified as Category X, no test required
Icing	24.0	Equipment identified as Category X, no test required
Electrostatic Discharge (ESD)	25.0	Equipment tested to Category A
Remarks:		

APPENDIX D - ACCESSORIES

This appendix includes information on accessory items available for the Apollo SL30. Refer to the information that is provided with those items for complete specifications and installation instructions.

FROM GARMIN AT, INC.

Splitter/Combiner

Garmin AT Part #:..... 115-0007
Manufacturer Mini-Circuits
Manufacturer Part #: ZFSC-2-1B BNC

The splitter/combiner is used when dual antennas and/or dual SL30s are installed in the aircraft. Refer to page 16.

Internal Fuse

Garmin AT Part #:..... S172-0007-012
Description 3 amp slow blow fuse

NOTES

APPENDIX E - SERIAL INTERFACE SPECIFICATIONS

This appendix includes the interface specifications for the RS-232 serial port. The RS-232 port can be used to input active and standby frequencies, and is used to input frequencies from a remote source, such as the SL50/60 and 2001 GPS. The interface format conforms to NMEA 0183 message format specifications.

INPUT COMMANDS

The following input command messages are supported:

- Input airport identifier associated with remote Comm frequency list
- Input Comm frequency data from a remote source
- Input VOR frequency data from a remote source
- End of VOR frequency list from a remote source
- Start of Localizer frequency list from a remote source
- Input Localizer frequency data from a remote source
- Request data output
- Set active VOR/LOC frequency data from a remote source
- Set standby VOR/LOC frequency data from a remote source
- Set standby COMM frequency data from remote source
- Set NAV audio mode
- Active COMM frequency
- Set Omni-Bearing Select (OBS) value from remote source
- DME sensor input

OUTPUT MESSAGES

SL30 output messages include:

- Reset status
- CDI, GSI, and flags
- Decoded OBS setting
- Radial from active VOR
- Radial from standby VOR
- Decoded station identifier
- Communications error
- NAV Receiver status
- NAV audio mode
- NAV microcontroller software version
- NAV DSP software version
- Comm transceiver status
- Comm software version
- ADC Data Output

DATA FORMAT

The data format for the serial communication is:

- Baud rate 9600
- Data bits 8
- Stop bits 1
- Parity none

DEFAULT MESSAGE OUTPUT

At system start when the SL30 is configured to operate in normal mode, the following messages will be configured for output at the specified rates:

- CDI, VDI, and Flags at 10Hz (high rate).
- Decoded OBS Setting at 10Hz (high rate).
- Radial from Active VOR at 10Hz (high rate).
- Radial from Standby VOR at 1Hz (low rate).
- Decoded Station Identifier at 1Hz (low rate).
- NAV Receiver Status at 1Hz (low rate).
- Comm Transceiver Status at 1Hz (low rate).

These default rates can be changed by using the Request Data Output message.

MESSAGE FORMATS

All messages will conform to the NMEA 0183 proprietary message format as follows. All characters will be standard ASCII characters. No binary data characters will be used.

“\$”	Start of message character, ASCII “\$” (024h).
“P”	Proprietary message identifier.
“MRR”	II Morrow company identifier.
c.....	Message class identifier. Used to identify a message as either a COMM or a VHF NAV message. Those message types which are also supported by the SL40 VHF Comm Radio Serial Interface will use the “C” identifier to allow the SL30 to accept COMM radio commands from existing products. All other messages will use the “V” identifier to indicate that they relate to a VHF NAV receiver.
nn	Message identifier, two-digit number in ASCII characters.
d.....d	Message data characters defined for each message.
chksum	Message checksum, including message identifier through data characters. The two-digit checksum is generated by adding all values of valid characters together, ignoring carry (if any). This value is converted into two encoded hex ¹ characters (30h-3Fh).

¹ Encoded hex: each character consists of 4 bits of data placed in the low order nibble +30h. For example, the 8-bit value 5Fh would be encoded as two characters with values of 35h and 3Fh, which map to the ASCII characters “5” and “?”, respectively.

<CR> ASCII carriage return (0Dh).
 <LF> ASCII line feed (0Ah).

The maximum message length, including the start of message character (“\$”) and the end of message <CR><LF> sequence, is 25 bytes.

This message format is the same as is used in the SL40 VHF Comm Radio. The SL30 will be able to accept all messages intended for an SL40 without generating a serial communications error. It will ignore all of those messages, the only exception being those messages used to input Comm frequency lists from a remote source.

MESSAGE DEFINITIONS

INPUT MESSAGES

Remote COMM Frequency Lists

The following two commands work together in allowing remotely connected devices to provide COMM frequency lists associated with an airport to the SL30. The host device should first send the Remote Airport Identifier Name command (message identifier 04), followed by a sequence of Remote Frequency Input commands (message identifier 05). The list type field is used to tie the two commands together. The SL30 will receive up to 10 Comm frequency lists, each containing up to twenty entries.

Remote Airport Identifier Name

This input command provides the airport identifier name that is used to identify to the user which airport facility that the list of frequencies is associated with.

Message format:

“C” Message Class. This is a COMM message.
 “04” Message Identifier.
 t..... List type: (ASCII) “0”, “1”, ..., “9”
 aaaa..... Airport Identifier of the frequency list. Note that if the airport identifier is 3 characters, then the 4th character will be filled with a space. Airport Identifiers are restricted to using ASCII characters 0-9 and A-Z.

Example message:

\$PMRRC041SLE<SP><checksum><CR><LF>

Airport Identifier to be associated with list #1, Airport Identifier to display is “SLE “.

Remote Airport Frequency Input

This message is used to input COMM frequency data used for the remote recall function.

The data included is a character defining the list type, a character defining the frequency type (tower, ground, ATIS, ...) and 2 characters defining the frequency. The SL30 module will accept the first 10 frequencies received through the serial port for each airport.

Message format:

- “C” Message Class. This is a COMM message.
- “05” Message Identifier.
- t List type: (ASCII) “0”, “1”, ..., “9”
- f Frequency type: 0-Fh; use encoded hex² (30h-3Fh).
 - 0 = Tower Frequency (TWR)
 - 1 = Ground (GND)
 - 2 = Automatic Terminal Information Service or ATIS (ATS)
 - 3 = Air Traffic Frequency (ATF)
 - 4 = Approach (APP)
 - 5 = Arrival (ARR)
 - 6 = Automatic Weather Observing Station (AWS)
 - 7 = Clearance/Delivery (CLR)
 - 8 = Common Traffic Advisory Frequency (CTF)
 - 9 = Departure (DEP)
 - : = Flight Service Station (FSS)
 - ; = Remote Flight Service Station (RFS)
 - < = Unicom (UNI)
 - = = Mandatory Frequency (MF)
 - > = No type specified
 - ? = undefined
- mk Frequency: m = MHz, where m = desired MHz frequency – 30h, with the desired frequency ranging from 118 to 136, or 46h to 48h; k = kHz, where k = (desired kHz offset / 25 kHz) + 30H, with the desired frequency range of 000 to 975 kHz in 25 kHz, or 30h to 57h.

Example message:

\$PMRRC0511IT<chksum><CR><LF>

Additional frequency list “1”, ground frequency type, 121.900 MHz.

REMOTE VOR LIST

The following two commands work together in allowing remotely connected devices to provide a list of VOR frequencies to the SL30. The remote device will send a sequence of Remote VOR Input commands (message identifier 20). When all of the VOR Input commands have been sent, the remote device should send a Remote VOR List Trailer command (message identifier 21) to terminate the list. The transmitted list will not be considered complete by the SL30 until it receives the trailer message. The unit will maintain a single remote VOR list, so each list received will replace any previous list. There may be up to twenty entries in the remote VOR list. Any entries past twenty will be ignored.

Remote VOR Input

This input is used to input VOR frequency data used for the remote recall function.

² Encoded hex: each character consists of a 4-bit data placed in the low order nibble +30h. For example, the 8-bit value 5Fh would be encoded as two characters with values of 35h and 3Fh, which map to the ASCII characters “5” and “?”, respectively.

The data consists of five characters for the VOR station identifier followed by two characters defining the VOR frequency.

Message format:

- “V” Message Class. This is a VHF NAV message.
- “20” Message Identifier.
- vvvv VOR station identifier. Note that if the station identifier is less than four characters, then the trailing characters will be filled with spaces. Station Identifiers are restricted to using ASCII characters 0-9 and A-Z.
- mk Frequency: m = MHz, where m = desired MHz frequency – 30h, with the desired frequency ranging from 108 to 117, or 3Ch to 45h; k = kHz, where k = (desired kHz offset / 25 kHz) + 30h, with desired frequency range of 000 to 975 kHz in 50 kHz steps, or the even numbers from 30h to 56h. Note that the field will be checked to ensure that it is in range and a valid VOR frequency. Frequencies used for localizers, which are in the range of 108.10 to 111.95 MHz, will not be accepted in this message type.

Example message:

\$PMRRV20UBG<Sp>E@<chksm><CR><LF>

VOR station identifier is “UBG ”, VOR frequency is 117.400 MHz.

Remote VOR List Trailer

This input command marks the end of a VOR list sent by a remote device.

Message format:

- “V” Message Class. This is a VHF NAV message.
- “21” Message Identifier

Example message:

\$PMRRV21<chksm><CR><LF>

Indicates the start of a remote VOR list.

REMOTE LOCALIZER LIST

The following two commands work together in allowing remotely connected devices to provide a list of localizer frequencies associated with an airport to the SL30. The remote device should first send the Remote Localizer List Header command (message identifier 22), followed by a sequence of Remote Localizer Input commands (message identifier 23). The SL30 maintains a single remote localizer list, so each new list received will replace any previous list. Subsequent receptions of localizer lists for the same airport are ignored. There may be up to twenty entries in the remote Localizer list. Any entries past twenty will be ignored.

Remote Localizer List Header

This input command marks the beginning of a Localizer list sent by a remote device. It specifies the five character airport identifier associated with the localizer frequencies in the list.

Message format:

- “V” Message Class. This is a VHF NAV message.
 “22” Message Identifier.
 aaaa..... Airport identifier. Note that if the airport identifier is less than four characters, then the trailing characters will be filled with spaces. Airport Identifiers are restricted to using ASCII characters 0-9 and A-Z.

Example message:

```
$PMRRV22SLE<Sp><chksum><CR><LF>
```

Indicates the start of a remote localizer list associated with the airport “SLE ”.

Remote Localizer Input

This input is used to input Localizer frequency data used for the remote recall function.

The data consists of three characters to identify the runway associated with the localizer, followed by two characters defining the frequency.

Message format:

- “V” Message Class. This is a VHF NAV message.
 “23” Message Identifier.
 iiii Station or Runway identifier. This field will provide an identifier for the localizer which can be either the actual station identifier or a string indicating the runway associated with the localizer. The station identifier can be up to four characters long. A runway identifier will typically be two numbers that indicate the runway direction followed by the character “R”, “C”, or “L” to differentiate between parallel runways (right, center, and left). Note that if either type of identifier is less than four characters, then the trailing characters will be filled in with spaces. Identifiers are restricted to using ASCII characters 0-9 and A-Z.
 mk..... Frequency: m = MHz, where m = MHz frequency – 30h, with the desired frequency ranging from 108 to 111 MHz, or 3Ch to 3Fh; k = (desired kHz offset / 25 kHz) + 30h, where the desired frequency ranges from 000 to 950 kHz, or the even numbers from 30h to 56h. Note that the field will be checked to ensure that it is in range and a valid localizer frequency. Frequencies used for VORs, which can also be found in the range of 108.10 to 111.95 MHz, will not be accepted in this message type.

Example message:

```
$PMRRV2331<Sp><Sp>><chksm><CR><LF>
```

Identifier is “31 ”, indicating a runway, and the localizer frequency is 110.300 MHz.

REQUEST DATA OUTPUT

This input is used to request an output message to be sent by the SL30.

Message format:

- “V” Message class. This is a VHF NAV message.
- “24” Message identifier.
- ii Output identifier of requested message, two ASCII characters.
- dd Message data, two encoded hex³ characters (30h-3Fh), used for specific output request. Set to “00” if not needed. These characters are used for such items as selecting a specific EEPROM address to output.
- a Request type: (ASCII) “0” = output once; “L” = output repeatedly at low speed (1 Hz); “H” = output repeatedly at high speed (10 Hz).

Table 5 - Data Output Requests

ii	Output	Dd	Data Description	a
“20”	Reset Status	“00”		“0”
“21”	CDI, GSI, and Flags	“00”		“0”, “L”, “H”
“22”	Decoded OBS Setting	“00”		“0”, “L”, “H”
“23”	Radial from Active VOR	“00”		“0”, “L”, “H”
“24”	Radial from Standby VOR	“00”		“0”, “L”
“25”	Decoded Station Identifier	“00”		“0”, “L”
“28”	Receiver Status	“00”		“0”
“29”	NAV Audio Mode	“00”		“0”
“30”	NAV Microcontroller Software Version	“00”		“0”
“31”	NAV DSP Software Version	“00”		“0”
“32”	ADC Data Output	cc	ADC channel: “00” to “08”	“0”
“35”	Comm Transceiver Status	“00”		“0”
“36”	Comm Software Version	“00”		“0”

Example messages:

```
$PMRRV242100L<chksm><CR><LF>
```

Request periodic output of CDI, GSI, and related flags at low (1 Hz) rate.

```
$PMRRV2432050<chksm><CR><LF>
```

Request a single output of ADC data from channel 5.

³ Encoded hex: each character consists of 4 bits of data placed in the low order nibble +30h. For example, the 8-bit value 5Fh would be encoded as two characters with values of 35h and 3Fh, which map to the ASCII characters “5” and “F”, respectively.

SET ACTIVE VOR/LOC FREQUENCY AND RECEIVER FUNCTION

This message is used to set the active VOR or Localizer frequency as well as the receiver operating function. The SL30 can detect if the supplied frequency corresponds to a VOR or a Localizer channel, so this command will work for both types of NAV aids.

Message format:

“V” Message class. This is a VHF NAV message.
 “27” Message identifier.
 mk..... Active VOR/LOC frequency:
 m = desired frequency in MHz in hexadecimal, where m = desired frequency - 30h, with desired frequency in range of 108 to 117 MHz.
 k = desired frequency in kHz, where k = (desired frequency / 25 kHz) + 30h, with desired frequency in range of 000 to 950 kHz in 50 kHz steps, or the even numbers from 30h to 56h.
 a..... Receiver function: N = normal; M = monitor; 0 = unchanged.

Example message:

```
SPMRRV27E4N<chksm><CR><LF>
```

This example command would set the active VOR frequency to 117.100 MHz. This can be interpreted by noting that the ASCII ‘E’ corresponds with 45h, +30h = 75h, converted to decimal equals 117 for the MHz portion of the command. The kHz portion converts ASCII ‘4’ to 34h, - 30h = 4h, x25 kHz steps = 100 kHz. This command would also set the receiver function to normal, leaving the standby channel inactive.

Note: The SL30 will check input frequencies for validity. An RS-232 serial error message output will be generated if the frequency is invalid.

SET STANDBY VOR/LOC FREQUENCY AND RECEIVER FUNCTION

This message is used to set the standby VOR or Localizer frequency as well as the receiver operating function. The SL30 can detect if the supplied frequency corresponds to a VOR or a Localizer channel, so this command will work for both types of NAV aids.

Message format:

“V” Message class. This is a VHF NAV message.
 “28” Message identifier.
 mk..... Standby VOR/LOC frequency:
 m = desired frequency in MHz in hexadecimal, where m = desired frequency - 30h, with desired frequency in range of 108 to 117 MHz.
 k = desired frequency in kHz, where k = (desired frequency / 25 kHz) + 30h, with desired frequency in range of 000 to 975 kHz in 50 kHz steps, or the even numbers from 30h to 56h.
 a..... Receiver function: N = normal; M = monitor; 0 = unchanged.

Example message:

\$PMRRV28?PM<chksm><CR><LF>

This example command would set the standby VOR frequency to 111.800 MHz. This is interpreted by noting that the ASCII '?' corresponds with 3Fh, +30h = 7Bh, converted to decimal equals 111 for the MHz portion. The kHz portion converts ASCII 'P' to 50h, -30h yields 20h, x25 kHz steps = 800 kHz. This command would also set the receiver function to monitor, so the receiver would time-multiplex the active and standby VOR channels to track both stations.

Note: The SL30 will check input frequencies for validity. An RS-232 serial error message output will be generated if the frequency is invalid.

SET STANDBY COMM FREQUENCY AND TRANSCEIVER FUNCTION

This message is used to set the standby COMM frequency.

Message format:

"V" Message class. This is a VHF NAV message.
"29" Message identifier.
mk Standby COMM frequency:
 m = desired frequency in MHz in hexadecimal, where m = desired frequency - 30h, with desired frequency in range of 118 to 136 MHz, or 162 MHz.
 k = desired frequency in kHz, where k = (desired frequency / 25 kHz) + 30h, with desired frequency in range of 000 to 975 kHz in 25 kHz steps.
a..... Transceiver function: N = normal, M = monitor, 0 = unchanged.

Example message:

\$PMRRV29G4M<chksm><CR><LF>

This example command would set the standby VOR frequency to 119.100 MHz. This is interpreted by noting that the ASCII 'G' corresponds with 47h, +30h = 77h, converted to decimal equals 119 for the MHz portion. The kHz portion converts ASCII '4' to 34h, -30h yields 4h, x25 kHz steps = 100 kHz.

Note: The SL30 will check input frequencies for validity. An RS-232 serial error message output will be generated if the frequency is invalid.

SET ACTIVE COMM FREQUENCY AND TRANSCEIVER FUNCTION

This message is used to set the Active COMM frequency as well as the COMM transceiver function.

This message is only available in normal mode.

Message format:

"V" Message class. This is a VHF NAV message.

“42” Message identifier.
 mk..... Active COMM frequency:
 m = desired frequency in MHz in hexadecimal, where m = desired
 frequency - 30h, with desired frequency in range of 118 to 136MHz, or
 162MHz.
 k = desired frequency in kHz, where k = (desired frequency / 25kHz) +
 30h, with desired frequency in range of 000 to 975kHz in 25kHz steps.
 a..... Transceiver function: N = normal, M = monitor, 0 = unchanged.

Example message:

```
$PMRRV42G4N<chksm><CR><LF>
```

This example command would set the active VOR frequency to 119.100MHz and place the COMM radio in Normal receive mode. This is interpreted by noting that the ASCII ‘G’ corresponds with 47h, +30h = 77h, converted to decimal equals 119 for the MHz portion. The KHz portion converts ASCII ‘4’ to 34h, -30h yields 4h, x25KHz steps = 100 kHz.

Note: The SL30 will check input frequencies for validity. An RS-232 serial error message output will be generated if the frequency is invalid.

Note: The SL30 will ignore this message while transmitting on the active COMM frequency.

SET NAV AUDIO MODE

This message is used to change the current NAV audio mode. There are three possible settings for this mode. The first is “OFF”, which suppresses all of the NAV audio. The second is “IDENT”, which will suppress the voice portion of the NAV audio signal and emphasize the Morse Code station identifier. The third choice is “VOICE”, which will emphasize voice signal and suppress the Morse Code station identifier.

Message format:

“V” Message class. This is a VHF NAV message.
 “31” Message identifier.
 a..... NAV audio mode. “0” = OFF, “I” = IDENT, “V” = VOICE

Example message:

```
$PMRRV31I<chksm><CR><LF>
```

Set the current NAV Audio mode to IDENT.

SET OMNI-BEARING SELECT (OBS) VALUE

This message is used to set the OBS value used by the SL30 as the selected radial for computing the course deviation from a VOR. This message will have no effect unless the SL30 is configured to use the internal OBS source, or a serial OBS source.

Message format:

- “V”Message class. This is a VHF NAV message.
- “34”Message identifier.
- vvvOBS Value in degrees, ranging from “000” to “359”.

Example message:

\$PMRRV34310<chksm><CR><LF>

Set the OBS value to 310 degrees.

DME SENSOR INPUT

This message is used to input the range, ground speed, and ETA decoded from an external DME sensor.

Message format:

- “V”Message class. This is a VHF NAV message.
- “41”Message identifier.
- rrrrRange from DME station in 1/10th of a nautical mile units. The first two digits are the 10s and 1s place of the range, and the last digit is the 1/10ths place. This field may range in value from 0.0 NM (“0000”) to 999.9 NM (“9999”). If the distance from the DME station is greater than 999.9NM, the value should be encoded as “----”.
- sss.....Ground speed with respect to DME station in knots. This field may range in value from 0 knots (“000”) to 999 knots (“999”). If the ground speed with respect to the DME station is greater than 999 knots, the value should be encoded as “---”.
- hmmTime to station in hours and minutes. This field may range in value from 0 hours and 0 minutes (“000”) to 9 hours and 59 minutes (“959”). If the time to the station is greater than 9 hours and 59 minutes, the value should be encoded as “---”.

Example message:

\$PMRRV410983055147<chksm><CR><LF>

Range from DME station is 98.3 NM, ground speed with respect to station is 55 knots, and the estimated time to the station is 1 hour and 47 minutes.

OUTPUT MESSAGES

RESET STATUS

This message is sent to indicate to the host that the SL30 is running and ready to accept data on the serial port. It will be sent once upon startup and when requested by the host.

Message format:

- “V”Message class. This is a VHF NAV message.
- “20”Message identifier.

Example message:

```
$PMRRV20<chksm><CR><LF>
```

SL30 is running and ready to accept serial input.

CDI, GSI, AND RELATED FLAGS

This message outputs the current values of the CDI, GSI, and their related flags. After power up this message will be output at a 10 Hz rate.

Message format:

“V” Message class. This is a VHF NAV message.
 “21” Message identifier.
 cc CDI deflection. An eight-bit value indicating the amount of deflection of the CDI needle, represented as two encoded hex⁴ digits. The CDI deflection is a twos complement signed integer in the range of –100 to 100. –100 indicates full left deflection, 0 indicates no deflection, and 100 indicates full right deflection.
 gg GSI deflection. An eight-bit value indicating the amount of deflection of the GSI needle, represented as two encoded hex⁴ digits. The CDI deflection is a twos complement signed integer in the range of –100 to 100. –100 indicates full deflection upwards, 0 indicates no deflection, and 100 indicates full deflection downwards.
 ff Flags. Eight bits for HNAV and VNAV related flags, represented as two encoded hex digits.

Bit 1 (lsb)	Back Course enable (1 = enabled)
Bit 2	Localizer detect (1 = using localizer)
Bit 3	FROM flag (1 = From) ⁵
Bit 4	TO flag (1 = To)
Bit 5	GSI superflag (1 = valid)
Bit 6	GSI valid (1 = valid)
Bit 7	NAV superflag (1 = valid)
Bit 8 (msb)	NAV valid (1 = valid)

Example message:

```
$PMRRV21817??:<chksm><CR><LF>
```

This message indicates a full left CDI deflection (-127), a full up GSI deflection (127), both the GSI and NAV flags/superflags are valid, TO flag set, FROM flag not set, using a localizer, with no back course enable.

⁴ Encoded hex: each character consists of 4 bits of data placed in the low order nibble +30h. For example, the 8-bit value 5Fh would be encoded as two characters with values of 35h and 3Fh, which map to the ASCII characters “5” and “?”, respectively.

⁵ The TO and FROM flag can not both be 1, indicating that they are both valid. They can both be zero, indicating that neither is valid. This situation will occur whenever the receiver determines that it is within the “cone of confusion” directly over a VOR, or when no signal is being received.

DECODED OBS SETTING

This message outputs the current OBS setting, which may be read from an external resolver or from user input to the front panel. After power up this message will be sent at a 10 Hz rate.

Message format:

“V” Message class. This is a VHF NAV message.
“22” Message identifier.
v Valid flag. “0” = OBS invalid/not present, “V” = OBS setting is valid.
ddd Three digit OBS setting, in degrees. Values are in the range of “000” to “359”.

Example message:

```
$PMRRV22V170<chksm><CR><LF>
```

A valid OBS setting of 170 degrees.

RADIAL FROM ACTIVE VOR

This message outputs the current bearing from the active VOR station. This message will be output even when a localizer is being tracked by the NAV receiver. In this case, the bearing will be marked as invalid. After power up this message will be sent at a 10 Hz rate.

Message format:

“V” Message class. This is a VHF NAV message.
“23” Message identifier.
v Valid flag. “0” = bearing not valid, “V” = bearing is valid.
dddf Bearing to a resolution of 1/10th of a degree. ddd = three digit bearing in degrees, ranging from “000” to “359”. f = 1/10th of a degree.

Example message:

```
$PMRRV23V1654<chksm><CR><LF>
```

A valid bearing of 165.4 degrees FROM the active VOR station.

RADIAL FROM STANDBY VOR

This message outputs the current bearing from the standby VOR station. This message will only contain valid data when the standby frequency is a VOR and the unit is in monitor mode. This message will be output even if valid data cannot be provided. In this case, the bearing will be marked as invalid. After power up this message will be sent at a 1 Hz rate.

Message format:

“V” Message class. This is a VHF NAV message.
“24” Message identifier.

- v..... Valid flag. "0" = bearing not valid, "V" = bearing is valid.
- dddf Bearing to a resolution of 1/10th of a degree. ddd = three digit bearing in degrees, ranging from "000" to "359". f = 1/10th of a degree.

Example message:

\$PMRRV24V1654<chksm><CR><LF>

A valid bearing of 165.4 degrees FROM the standby VOR station.

DECODED STATION IDENTIFIER

This message outputs the decoded station identifier received on the NAV voice channel. This message will be output even if the station identifier has not been decoded yet. In this case, the message will be flagged as invalid. Note that the validity of this message does not depend on the current NAV audio mode. The decoding is done automatically regardless of this setting. After power up this message will be sent at a 1 Hz rate.

Message format:

- "V" Message class. This is a VHF NAV message.
- "25" Message identifier.
- v..... Valid flag. "0" = identifier is not valid, "V" = decoded station identifier is valid.
- iiii Decoded station identifier, five characters long. If the decoded identifier is less than five characters in length, then the trailing characters will be filled in with spaces. Identifiers are restricted to using ASCII character 0-9 and A-Z.

Example message:

\$PMRRV25VISLE<Sp><chksm><CR><LF>

The decoded station identifier is valid and is "ISLE".

COMMUNICATIONS ERROR

This message is used to indicate a communication error.

Message format:

- "V" Message class. This is a VHF NAV message.
- "27" Message identifier.
- e..... Error code: (ASCII)
 - "0" = input message checksum error.
 - "1" = unknown message.
 - "2" = error or mismatch in message data.

Example message:

\$PMRRV271<chksm><CR><LF>

Received an unknown message.

NAV RECEIVER STATUS

This message is used to output the current status of the NAV receiver. It will be output upon request or whenever the status changes.

Message format:

“V” Message class. This is a VHF NAV message.
“28” Message identifier.
mk Active NAV frequency: m = MHz, where m + 30h = desired MHz
frequency in the range of 108 to 117 MHz.
k = desired frequency in kHz, where k = (desired frequency / 25 kHz) +
30h, with desired frequency in range of 000 to 975 kHz in 50 kHz steps.
mk Standby NAV frequency: m = MHz, where m + 30h = desired MHz
frequency in the range of 108 to 117 MHz.
k = desired frequency in kHz, where k = (desired frequency / 25 kHz) +
30h, with desired frequency in range of 000 to 975 kHz in 50 kHz steps.
s Status: “N” = Normal mode, “M” = Monitor mode

Example message:

\$PMRRV28E4?PM<chksm><CR><LF>

Active NAV frequency is 117.100 MHz, Standby NAV frequency is 111.800 MHz, receiver is in monitor mode.

NAV AUDIO MODE

This message is used to output the current NAV audio mode. There are three possible settings for this mode. The first is “OFF”, which suppresses all of the NAV audio. The second is “IDENT”, which will suppress the voice portion of the NAV audio signal and emphasize the Morse Code station identifier. The third choice is “VOICE”, which will emphasize voice signal and suppress the Morse Code station identifier.

Message format:

“V” Message class. This is a VHF NAV message.
“29” Message identifier.
a NAV audio mode. “0” = OFF, “I” = IDENT, “V” = VOICE

Example message:

\$PMRRV29I<chksm><CR><LF>

The current NAV Audio mode is “IDENT”.

NAV MICROCONTROLLER SOFTWARE VERSION

This message is used to output the version string for the NAV microcontroller software.

Message format:

“V” Message class. This is a VHF NAV message.
 “30” Message identifier.
 vvvv Software version in ASCII
 e Engineering version flag:
 “R” = Released version.
 “E” = Engineering version.

Example message:

```
$PMRRV300103E<chksm><CR><LF>
```

NAV Microcontroller software is version 1.03. It is an engineering version.

NAV DSP SOFTWARE VERSION

This message is used to output the version string for the NAV DSP software.

Message format:

“V” Message class. This is a VHF NAV message.
 “31” Message identifier.
 vvvv Software version in ASCII
 e Engineering version flag:
 “R” = Released version.
 “E” = Engineering version.

Example message:

```
$PMRRV310101R<chksm><CR><LF>
```

NAV DSP software is version 1.01. It is a released version.

ADC DATA OUTPUT

This message outputs the current value of one of the ADC (Analog to Digital Converter) channels read by the NAV Microcontroller.

This message is only available in normal mode.

Message format:

“V” Message class. This is a VHF NAV message.
 “32” Message identifier.
 c ADC channel: “0” to ”8”
 0 = Input voltage level, in units of 125 mV.
 1 = 3.3V reference, in units of 15 mV, value ranges from 0 to 255.
 2 = 5V reference, in units of 25 mV, value ranges from 0 to 255.

- 3 = 12V reference, in units of 50 mV, value ranges from 0 to 255.
- 4 = 28V reference, in units of 125 mV, value ranges from 0 to 255.
- 5 = Volume potentiometer, value ranges from 0 to 255.
- 6 = Photocell, value ranges from 0 to 255.
- 7 = Display thermistor, value ranges from 0 to 255.
- 8 = Crystal thermistor, value ranges from 0 to 255.

vv Value. A two digit encoded hex number representing the latest value read from the specified ADC channel.

Example message:

\$PMRRV32637<chksm><CR><LF>

The latest value read from the Photocell (channel 6) is 0x37.

COMM TRANSCEIVER STATUS

This message outputs the result of a specific system test.

Message format:

- “V” Message class. This is a VHF NAV message.
- “35” Message identifier.
- mk Active frequency: m = MHz, where m = desired MHz frequency - 30h, ranging from 118 to 136 MHz, 162 (i.e., 76h to 88h, A2h); k = (kHz offset / 25 kHz) + 30h, ranging from 000 to 975 kHz in 25 kHz steps.
- mk Standby frequency: m = MHz, where m = desired MHz frequency - 30h, ranging from 118 to 136 MHz, 162 (i.e., 76h to 88h, A2h); k = (kHz offset / 25 kHz) + 30h, ranging from 000 to 975 kHz in 25 kHz steps.
- a..... Transceiver status:
 - R = Normal receive
 - M = Monitor receive
 - T = Transmit enabled
 - S = Stuck mic
 - F = Comm failure
- s..... Squelch test setting: (ASCII) 0 = automatic; 1 = test

Example message:

\$PMRRV35G4LFR0<chksm><CR><LF>

Active frequency is 119.100 MHz, the standby frequency is 124.550 MHz, receive function, squelch is automatic.

COMM SOFTWARE VERSION

This message is used to output the version string for the VHF Comm receiver software.

Message format:

“V” Message class. This is a VHF NAV message.
“36” Message identifier.
vvvv Software version in ASCII

Example message:

\$PMRRV300103<chksm><CR><LF>

Comm software is version 1.03.

NOTES



Free Manuals Download Website

<http://myh66.com>

<http://usermanuals.us>

<http://www.somanuals.com>

<http://www.4manuals.cc>

<http://www.manual-lib.com>

<http://www.404manual.com>

<http://www.luxmanual.com>

<http://aubethermostatmanual.com>

Golf course search by state

<http://golfingnear.com>

Email search by domain

<http://emailbydomain.com>

Auto manuals search

<http://auto.somanuals.com>

TV manuals search

<http://tv.somanuals.com>