

GTX 23

Transponder

Installation Manual



© 2014

Garmin Ltd. or its subsidiaries
All Rights Reserved

Except as expressly provided herein, no part of this manual may be reproduced, copied, transmitted, disseminated, downloaded or stored in any storage medium, for any purpose without the express prior written consent of Garmin. Garmin hereby grants permission to download a single copy of this manual and of any revision to this manual onto a hard drive or other electronic storage medium to be viewed and to print one copy of this manual or of any revision hereto, provided that such electronic or printed copy of this manual or revision must contain the complete text of this copyright notice and provided further that any unauthorized commercial distribution of this manual or any revision hereto is strictly prohibited.

Garmin International, Inc.
1200 E. 151st Street
Olathe, KS 66062 USA
Telephone: 913.397.8200
Aviation Panel-Mount Technical Support Line (Toll Free) 1.888.606.5482
www.garmin.com

Garmin (Europe) Ltd.
Liberty House, Hounslow Business Park
Southampton, Hampshire SO40 9LR U.K.
+44/ (0) 23 8052 4000

Garmin AT, Inc.
2345 Turner Rd., SE
Salem, OR 97302 USA
Telephone: 503.581.8101

RECORD OF REVISIONS

Revision	Revision Date	Description
A	08/31/2011	Initial release
B	09/11/2012	Updated for SW v7.01
C	06/06/14	Updated mounting rack info

INFORMATION SUBJECT TO EXPORT CONTROL LAWS

This document may contain information which is subject to the Export Administration Regulations ("EAR") issued by the United States Department of Commerce (15 CFR, Chapter VII, Subchapter C) and which may not be exported, released, or disclosed to foreign nationals inside or outside of the United States without first obtaining an export license. The preceding statement is required to be included on any and all reproductions in whole or in part of this manual.

DEFINITIONS OF WARNINGS, CAUTIONS, AND NOTES



WARNING

Warnings are used to bring to the installer's immediate attention that not only damage to the equipment but personal injury may occur if the instruction is disregarded.



CAUTION

Cautions are used to alert the individual that damage to equipment may result if the procedural step is not followed to the letter.



NOTE

Notes are used to expand and explain the preceding step and provide further understanding of the reason for the particular operation.



WARNING

This product, its packaging, and its components contain chemicals known to the State of California to cause cancer, birth defects, or reproductive harm. This Notice is being provided in accordance with California's Proposition 65. If you have any questions or would like additional information, please refer to our web site at www.garmin.com/prop65.



WARNING

Perchlorate Material – special handling may apply. See www.dtsc.ca.gov/hazardouswaste/perchlorate.

CURRENT REVISION DESCRIPTION

Revision	Page Number(s)	Section Number	Description of Change
C	1-5	1.7	Added modular rack info to physical characteristics table
	1-8	1.9.2	Updated TSO/ETSO Deviations Table 1-6
	1-9	1.10	Updated operating instructions info
	2-1	2.2	Added new unit w/system rack part number
	2-1	2.2.1	Added modular rack to equipment available table
	2-2	2.2.2	Added modular rack mounting hardware info
	2-5, 2-6	2.6 , 2.6.1 , & 2.6.2	Updated mounting requirements info, added modular rack info and added Figure 2-3
	A-1	Appdx A	Made corrections to static load testing info
	C-2	Appdx C	Corrected pin number on P1001, Figure C-2
	D-1–D-4	Appdx D	Made corrections to Figures A-1 & A-2, added Figures A-3 & A-4

Aviation Limited Warranty

All Garmin avionics products are warranted to be free from defects in materials or workmanship for: two years from the date of purchase for new Remote-Mount and Panel-Mount products; one year from the date of purchase for new portable products and any purchased newly-overhauled products; six months for newly-overhauled products exchanged through a Garmin Authorized Service Center; and 90 days for factory repaired or newly-overhauled products exchanged at Garmin in lieu of repair. Within the applicable period, Garmin will, at its sole option, repair or replace any components that fail in normal use. Such repairs or replacement will be made at no charge to the customer for parts or labor, provided that the customer shall be responsible for any transportation cost. This warranty does not apply to: (i) cosmetic damage, such as scratches, nicks and dents; (ii) consumable parts, such as batteries, unless product damage has occurred due to a defect in materials or workmanship; (iii) damage caused by accident, abuse, misuse, water, flood, fire, or other acts of nature or external causes; (iv) damage caused by service performed by anyone who is not an authorized service provider of Garmin; or (v) damage to a product that has been modified or altered without the written permission of Garmin. In addition, Garmin reserves the right to refuse warranty claims against products or services that are obtained and/or used in contravention of the laws of any country.

THE WARRANTIES AND REMEDIES CONTAINED HEREIN ARE EXCLUSIVE AND IN LIEU OF ALL OTHER WARRANTIES, WHETHER EXPRESS, IMPLIED OR STATUTORY, INCLUDING ANY LIABILITY ARISING UNDER ANY WARRANTY OF MERCHANTABILITY OR FITNESS FOR A PARTICULAR PURPOSE, STATUTORY OR OTHERWISE. THIS WARRANTY GIVES YOU SPECIFIC LEGAL RIGHTS, WHICH MAY VARY FROM STATE TO STATE.

IN NO EVENT SHALL GARMIN BE LIABLE FOR ANY INCIDENTAL, SPECIAL, INDIRECT OR CONSEQUENTIAL DAMAGES, WHETHER RESULTING FROM THE USE, MISUSE OR INABILITY TO USE THE PRODUCT OR FROM DEFECTS IN THE PRODUCT. SOME STATES DO NOT ALLOW THE EXCLUSION OF INCIDENTAL OR CONSEQUENTIAL DAMAGES, SO THE ABOVE LIMITATIONS MAY NOT APPLY TO YOU.

Garmin retains the exclusive right to repair or replace (with a new or newly-overhauled replacement product) the product or software or offer a full refund of the purchase price at its sole discretion. SUCH REMEDY SHALL BE YOUR SOLE AND EXCLUSIVE REMEDY FOR ANY BREACH OF WARRANTY.

Online Auction Purchases: Products purchased through online auctions are not eligible for warranty coverage. Online auction confirmations are not accepted for warranty verification. To obtain warranty service, an original or copy of the sales receipt from the original retailer is required. Garmin will not replace missing components from any package purchased through an online auction.

International Purchases: A separate warranty may be provided by international distributors for devices purchased outside the United States depending on the country. If applicable, this warranty is provided by the local in-country distributor and this distributor provides local service for your device. Distributor warranties are only valid in the area of intended distribution. Devices purchased in the United States or Canada must be returned to the Garmin service center in the United Kingdom, the United States, Canada, or Taiwan for service.

Garmin International, Inc.
1200 East 151st Street
Olathe, Kansas 66062, U.S.A.
Phone: 913/397.8200
FAX: 913/397.0836

Garmin (Europe) Ltd.
Liberty House, Hounslow Business Park
Southampton, Hampshire, SO40 9LR, U.K.
Phone: 44/ (0) 23 8052 4000
FAX: 44/ (0) 23 8052 4004
Aviation Support: 44 (0) 87 0850 1243

TABLE OF CONTENTS

PARAGRAPH	PAGE
Section 1 GENERAL DESCRIPTION	1-1
1.1 Introduction.....	1-1
1.2 Equipment Description	1-1
1.3 ADS-B Capabilities	1-2
1.4 TIS System Capabilities.....	1-3
1.5 Mutual Suppression Pulses	1-4
1.6 Interface Summary.....	1-4
1.7 Technical Specifications	1-5
1.8 License Requirements.....	1-6
1.9 Certification	1-6
1.10 Operating Instructions.....	1-9
1.11 Reference Documents	1-9
Section 2 INSTALLATION OVERVIEW.....	2-1
2.1 Introduction.....	2-1
2.2 Installation Materials	2-1
2.3 Installation Considerations	2-3
2.4 Cabling and Wiring.....	2-4
2.5 Cooling Air	2-5
2.6 GTX 23 Mounting Requirements	2-5
Section 3 INSTALLATION PROCEDURE.....	3-1
3.1 Unpacking Unit.....	3-1
3.2 Wiring Harness Installation	3-1
3.3 Electrical Connections	3-1
3.4 Backshell Assembly.....	3-2
3.5 Weight and Balance	3-2
3.6 Electrical Load Analysis.....	3-2
3.7 Final Installation	3-3
3.8 Post Installation Configuration and Checkout	3-3
3.9 Continued Airworthiness	3-4
Section 4 SYSTEM INTERCONNECTS.....	4-1
4.1 Pin Function List.....	4-1
4.2 Discrete Functions	4-3
4.3 Serial Data Electrical Characteristics	4-5
4.4 RS-232 Input/Output, Software Update Connections.....	4-6
Appendix A CONSTRUCTION AND VALIDATION OF STRUCTURES A-1	
A.1 Static Test Loading	A-1
A.2 Determining Static Load Capability	A-1

Appendix B SHIELD BLOCK INSTALLATION INSTRUCTIONS	B-1
B.1 Shield Block Installation Parts	B-1
B.2 Shield Termination Technique – Method A.1 (Standard).....	B-3
B.3 Shield Termination Technique - Method A.2 (Daisy Chain).....	B-7
B.4 Shield Termination – Method B.1 (Quick Term).....	B-7
B.5 Shield Termination-Method B.2 (Daisy Chain-Quick Term)	B-9
B.6 Daisy Chain between Methods A and B	B-10
B.7 Splicing Signal Wires.....	B-10
 Appendix C INTERCONNECT DRAWINGS (Example Only).....	C-1
 Appendix D OUTLINE AND INSTALLATION DRAWINGS.....	D-1

LIST OF FIGURES

FIGURE	PAGE
Section 1 GENERAL DESCRIPTION	1-1
Section 2 INSTALLATION OVERVIEW.....	2-1
Figure 2-1. Antenna Installation Considerations	2-3
Figure 2-2. GTX 23 Stand-Alone Rack (115-00629-00).....	2-6
Figure 2-3. GTX 23 Modular Rack (115-00438-00)	2-6
Figure 2-4. GTX 23 Stand-Alone Rack, Suggested Mounting Locations	2-7
Section 3 INSTALLATION PROCEDURE	3-1
Section 4 SYSTEM INTERCONNECTS.....	4-1
Figure 4-1. J2301 Connector	4-1
Figure 4-2. GTX 23 Software Update Connections	4-6
Appendix A CONSTRUCTION AND VALIDATION OF STRUCTURES A-1	
Figure A-1. Upward static Load Test	A-2
Figure A-2. Forward Static Load Test	A-2
Appendix B SHIELD BLOCK INSTALLATION INSTRUCTIONS.....	B-1
Figure B-1 Shield Block Installation (78 pin example).....	B-2
Figure B-2 Method A.1 for Shield Termination	B-3
Figure B-3 Insulation/Contact Clearance	B-5
Figure B-4 Method A.2 (Daisy Chain) for Shield Termination	B-7
Figure B-5 Method B.1 (Quick Term) for Shield Termination	B-8
Figure B-6 Method B.2 (Daisy Chain-Quick Term) for Shield Termination	B-9
Figure B-7 Daisy Chain between Methods A and B	B-10
Figure B-8 D-Sub Spliced Signal Wire illustration	B-11
Appendix C INTERCONNECT DRAWINGS (Example Only)	C-1
Figure C-1 Core Interconnect Examples	C-1
Figure C-2 ADS-B Interconnect Examples	C-2
Figure C-3 TIS Display Options Example.....	C-3
Appendix D OUTLINE AND INSTALLATION DRAWINGS	D-1
Figure D-1 GTX 23 in Standalone Rack, Outline Drawing	D-1
Figure D-2 GTX 23 Connector/Standalone Rack Assembly Drawing	D-2
Figure D-3 GTX 23 in Modular Rack, Outline Drawing	D-3
Figure D-4 GTX 23 Connector/Modular Rack Assembly Drawing.....	D-4

LIST OF TABLES

TABLE	PAGE
Section 1 GENERAL DESCRIPTION	1-1
Table 1-1 ADS-B Versions	1-2
Table 1-2 Physical Characteristics	1-5
Table 1-3 General Specifications	1-5
Table 1-4 Power Requirements	1-6
Table 1-5 TSO/ETSO/RTCA/ICAO Compliance	1-7
Table 1-6 TSO/ETSO Deviations	1-8
Table 1-7 Reference Documents	1-9
Section 2 INSTALLATION OVERVIEW	2-1
Table 2-1 Installation Materials	2-1
Table 2-2 Equipment Available	2-1
Table 2-3 Cable Specifications	2-4
Section 3 INSTALLATION PROCEDURE	3-1
Table 3-1 Pin Contact Part Numbers (High Density)	3-1
Table 3-3 Unit Power Loads	3-2
Table 3-2 Recommended Crimp Tools (High Density)	3-2
Section 4 SYSTEM INTERCONNECTS	4-1
Table 4-1 P2301 Pin Assignments	4-1
Table 4-2 Aircraft Power	4-3
Table 4-3 Discrete Outputs	4-3
Table 4-4 Discrete Inputs	4-4
Table 4-5 RS-232 Input/Output	4-5
Table 4-6 ARINC 429 Input/Output	4-5
Appendix A CONSTRUCTION AND VALIDATION OF STRUCTURES A-1	
Table A-1 Static Test Load	A-1
Appendix B SHIELD BLOCK INSTALLATION INSTRUCTIONS	B-1
Table B-1 Parts Supplied for a Shield Block Installation (011-01012-01)	B-1
Table B-2 Parts Not Supplied for a Shield Block Installation (Figure B-1)	B-1
Table B-3 Shielded Cable Preparations for Garmin Connectors	B-3
Table B-4 Shielded Cable Preparations – (Quick Term)	B-9
Appendix C INTERCONNECT DRAWINGS (Example Only)	C-1
Appendix D OUTLINE AND INSTALLATION DRAWINGS	D-1

1 GENERAL DESCRIPTION

1.1 Introduction

This manual is intended to provide mechanical and electrical information for use in the planning and design of an installation of the GTX 23 into an aircraft. This manual is not a substitute for an approved airframe-specific maintenance manual, installation design drawing, or complete installation data package. Attempting to install equipment by reference to this manual alone and without first planning or designing an installation specific to your aircraft may compromise your safety and is not recommended. The content of this manual assumes use by competent and qualified avionics engineering personnel and/or avionics installation specialists using standard aviation maintenance practices in accordance with Title 14 of the Code of Federal Regulations and other relevant accepted practices. This manual is not intended for use by individuals who do not possess the competencies and abilities set forth above.



NOTE

Garmin recommends installation of the GTX 23 by a Garmin-authorized installer. To the extent allowable by law, Garmin will not be liable for damages resulting from improper or negligent installation of the GTX 23. For questions, please contact Garmin Aviation Product Support at 1-888-606-5482.

1.2 Equipment Description

The Garmin GTX 23 remote-mounted Mode S Transponder is a radio transmitter and receiver that operates on radar frequencies. It receives ground radar and TCAS interrogations at 1030 MHz, and it transmits a coded response of pulses at 1090 MHz. The GTX 23 replies to Mode A, Mode C, and Mode S interrogations. Mode A replies consist of framing pulses and any one of 4,096 codes, which differ in the position and number of pulses transmitted. Mode C replies include framing pulses and encoded pressure altitude. Mode S replies can contain various information such as the Mode A code, Mode C altitude, ICAO address, and Elementary Surveillance and Enhanced Surveillance data described below.

Features of the GTX 23 include support for ADS-B, TIS-A, mutual suppression, IDENT functionality, SI codes, elementary surveillance (ELS), and enhanced surveillance (EHS). ADS-B, TIS-A, and mutual suppression are discussed in following sections. IDENT functionality activates a Special Position Identification (SPI) pulse for 18 seconds in Mode A replies. This helps the air traffic controller confirm your position on their radar screen. SI codes, ELS, and EHS better facilitate meeting various requirements for operation in European airspace. SI codes uniquely identify ground radar with overlapping coverage. Supporting SI codes enables reduction in ground infrastructure complexity. ICAO Annex 10, Volume IV, Amendment 77, paragraph 2.1.5.1.7.1 mandated SI code support. Elementary and Enhanced Surveillance provide additional aircraft parameters to ground radar systems (for ELS, see JAA TGL 13 rev 1 dated June 01, 2003; for EHS, see AMC 20-13, which supersedes JAA NPA 20-12a). Elementary Surveillance provides a detailed transponder capability report and aircraft identification data (e.g. Flight ID or radio call sign). Additionally, TCAS II compatible transponders supporting ELS can provide resolution advisory data if the aircraft is equipped with TCAS II. (ELS is Mode S BDS registers (1,0), (2,0), and (3,0).) Enhanced Surveillance provides selected vertical intention, track and turn reporting, and heading and speed reporting. (EHS is Mode S BDS registers (4,0), (5,0), and (6,0).)

1.3 ADS-B Capabilities

The GTX 23 provides the capabilities of Automatic Dependent Surveillance-Broadcast (ADS-B) technology, which improves situational awareness and flight safety. With ADS-B capabilities, position, velocity, and heading information are automatically transmitted to other aircraft and ground stations. The current air traffic control system depends on a transponder request for pertinent aircraft information. ADS-B provides automatic transmission of aircraft information without a request.



NOTE

RS-232 ADS-B Out from a Garmin 4XX/5XX WAAS, GTN 6XX/7XX with GPS software version 3.20 or later, or a GPS WAAS source that supports ARINC 743A output is required to support ADS-B transmissions.

1.3.1 ADS-B Versions

There are three distinct ADS-B versions recognized by regulatory authorities. As shown in the table below, the Garmin GTX 23 w/ES currently supports ADS-B Out 1090MHz Extended Squitter capability meeting 'Version 1' or 'Version 2' ADS-B system requirements depending on software version (Table 1-1).

Table 1-1 ADS-B Versions

ADS-B Version	GTX 23 w/ES Compliant	Supported SW Version	Regulatory Standard/Minimum Performance Specification
Version 1 (applies to 006-B1417-00 Rev. A (v6.20))	Yes	6.00 - 6.20	Equipment designed to TSO-166a / RTCA DO-260A
Version 2* (applies to All 006-B1417-00 Rev. () except 006-B1417-00 Rev. A (v6.20))	Yes	7.01 and later	Equipment designed to TSO-166b / RTCA DO-260B

*Version required by 2020 ADS-B Out mandate defined in 14 CFR 91.225

1.3.1.1 Installation Approval of Version 1 ADS-B Systems

GTX 23 w/ES transponders running software versions v6.00 through v6.20 support Version 1 ADS-B Out functionality. According to AIR-130 Policy Memo ‘Approval for ADS-B Out Systems’, dated August 30, 2010, the FAA has suspended field approvals of Version 2 ADS-B Out equipment. At the time of this publication, there is currently no FAA policy addressing field approvals of Version 0 or Version 1 systems. GTX 23 w/ES transponders with Version 1 ADS-B remain eligible for field approval.

There are three options for installers wanting to install GTX 23 w/ES transponders with software versions 6.00 through 6.20:

1. Installers may elect to disable the ADS-B Extended Squitter function, as described in [Section 3.8](#).
2. Installers may utilize a Supplemental Type Certificate (STC) for the GTX 330 with the Version 1 ADS-B Extended Squitter activated.
3. Installers may obtain a field approval with the Version 1 ADS-B Extended Squitter activated. EASA AMC 20-24 compliance matrix provided in Appendix B may be used to assist installers in showing compliance to the AMC requirements. This data together with Form 337 may be used for approval by the appropriate FSDO inspector.

1.3.1.2 Installation Approval of Version 2 ADS-B Systems

GTX 23 w/ES transponders running software versions v7.01 and later support Version 2 ADS-B Out functionality. According to AIR-130 Policy Memo ‘Approval for ADS-B Out Systems’, dated August 30, 2010, a Supplemental Type Certificate (STC) is required for the approval of Version 2 ADS-B Out equipment.

There are two options for installers wanting to install GTX 23 w/ES transponders running software versions v7.01 and later:

1. Installers may elect to disable the ADS-B Extended Squitter function, as described in [Section 3.8](#).
2. Installers must utilize a Supplemental Type Certificate (STC) for the GTX 23 with the Version 2 ADS-B Extended Squitter activated.



NOTE

It is the installer’s responsibility to ensure the ADS-B Out system is compliant with AC 20-165 and to ensure compatibility between the GTX 23 and the ADS-B Out position source equipment. See Garmin ADS-B Out Compatible Equipment (190-01533-00) for compatible equipment shown to be eligible for 14 CFR 91.227-compliant installations in accordance with AC 20-165

1.4 TIS System Capabilities

Traffic Information Service (TIS) provides a graphic display of traffic advisory information in the cockpit for non-TCAS equipped aircraft.

TIS is a ground-based service providing relative location of all transponder equipped aircraft within a specified service volume. The TIS ground sensor uses real time track reports to generate traffic notification.

Traffic display is available to aircraft equipped with a Mode S data link such as the Garmin GTX 23 transponder. Traffic can then be displayed on a Garmin GDU Primary Flight Display, or GNS 400W/500W-series unit.

Surveillance data includes all transponder equipped aircraft within the coverage volume. Aircraft without an operating transponder are invisible to TIS. TIS displays traffic within seven nautical miles from 3000 feet below to 3500 feet above the requesting aircraft.

1.5 Mutual Suppression Pulses

Other equipment on board the aircraft may transmit in the same frequency band as the transponder. DME, TCAS, or another transponder are examples of equipment that operate in the same frequency band. Mutual suppression is a synchronous pulse that is sent to the other equipment to suppress transmission of a competing transmitter for the duration of the transmission. The transponder transmission is suppressed by an external source, and other equipment on board that transmit in the same frequency band are suppressed by the GTX 23 transponder. This feature is designed to limit mutual interference.

1.6 Interface Summary

The GTX 23 provides the following interface connections via the rear connector. See Section 4 and Appendix C for connection details.

- External IDENT input
- External STBY input (useful for dual transponder installations)
- External mutual suppression pulse input/output
- Aircraft power input (14/28 Vdc)
- RS-232 input #1 connection for altitude and unit control data
- RS-232 output #1 connection for TIS and unit status
- RS-232 input #2 connection for GPS data for ADS-B
- Supports Comm-A and Comm-B protocol
- ARINC 429 outputs for TIS data

The GTX 23 supports the following list of Comm-B Definition Subfield (BDS) registers:

- BDS (0,0) Air Initiated Comm-B (AICB)
- BDS (1,0) Data Link Capability Report
- BDS (1,7) Common Usage Ground Initiated Comm-B (GICB) Capability Report
- BDS (1,8) Mode S Specific Services GICB Capability Report
- BDS (1,9) Mode S Specific Services GICB Capability Report
- BDS (1,D) Mode S Specific Services Protocols (MSP) Capability Report
- BDS (2,0) Aircraft Identification
- BDS (4,0) Selected Vertical Intention
- BDS (5,0) Track and Turn Report
- BDS (6,0) Heading and Speed Report
- BDS (0,6) Extended Squitter surface Position
- BDS (0,5) Extended Squitter Airborne Position
- BDS (0,8) Extended Squitter Aircraft Identification and Category
- BDS (0,9) Extended Squitter Airborne Velocity – Subtypes 1 and 3
- BDS (0,A) Extended Squitter Event Driven Data
- BDS (6,1) Emergency/Priority Status
- BDS (6,5) Aircraft operational Status

1.7 Technical Specifications

1.7.1 Physical Characteristics

Table 1-2 Physical Characteristics

Characteristic	Specification
Modular Rack Width	1.72 inches [44 mm]
Modular Rack Height	6.30 inches [160 mm]
Modular Rack Weight	0.4 lbs [0.18 kg]
Stand-Alone Rack Width	1.78 Inches (45 mm)
Stand-Alone Rack Height	6.92 Inches (176 mm)
Stand-Alone Rack Weight	0.9 lbs. (0.41 kg)
Depth Including Connectors (measured from front face of unit to rear of connector backshells)	11.05 Inches (281 mm)
Depth Including Connectors and Shield Blocks (measured from front face of unit to rear of shield blocks)	11.44 inches (291 mm)
Connector Weight (including backshell)	0.4 lbs (0.18 kg)
GTX 23 Unit Weight	3.1 lbs. (1.41 kg)

1.7.2 General Specifications

Table 1-3 General Specifications

Characteristic	Specification
Regulatory Compliance; GTX 23 w/ES	RTCA DO-160D, RTCA DO-181C, RTCA DO-260B, EuroCAE ED-102A, EuroCAE ED-73A, EuroCAE ED-73B
Unit Software	RTCA DO-178B Level C
Complex Electronic Hardware	RTCA/DO-254 Level C
FCC Authorization	Emission Designator 12M0M1D
Temperature Range	-45°C to +70°C (continuous operation)
Altitude	55,000 Feet
Transmitter Frequency	1090 MHz \pm 1 MHz
Transmitter Power	125 Watts minimum, 250 Watts nominal
Receiver Frequency	1030 MHz
Receiver Sensitivity	-74 dBm nominal for 90% replies
Mode A Capability	4096 Identification Codes
Mode C Capability	100 Foot Increments from -1000 to 62,700 feet. 25 Foot Increments from -1000 to 50,175 feet with suitable serial data altitude.
Mode S Capability	4096 Identification Codes, Altitude
External Suppression Input	Low \leq 0.5 V; High \geq 8 V

Table 1-3 General Specifications

Characteristic	Specification
External Suppression Output	Output: minimum is +18V (for 300 ohm load) and maximum of +23V (for 2000 ohm load)
Audio Output	4.04 Vrms to 7.85 Vrms into a 500 ohm load

1.7.3 Power Requirements

Table 1-4 Power Requirements

Characteristic	Specification
Input Voltage	14/28 Vdc See the Environmental Qualification Form for details on surge ratings and minimum/maximum operating voltages.
Power Input	22 Watts Typical, 45 Watts Maximum
Maximum Full TSO Reply Rate; Mode C, 1200 PRF, Code 7777	1.6 A @ 28 Vdc, 3.1 A @14 Vdc
Maximum Quiescent	0.85 A @ 28 Vdc, 1.1A @ 14 Vdc

1.8 License Requirements

The Telecommunications Act of 1996, effective February 8, 1996, provides the FCC discretion to eliminate radio station license requirements for aircraft and ships. The GTX 23 installation must comply with current transmitter licensing requirements. To find out the specific details on whether a particular installation is exempt from licensing, please visit the FCC web site <http://wireless.fcc.gov/aviation>.

If an aircraft license is required, make application for a license on FCC form 404, Application for Aircraft Radio Station License. The FCC also has a fax-on-demand service to provide forms by fax. The GTX 23 owner accepts all responsibility for obtaining the proper licensing before using the GTX 23.



CAUTION

The UHF transmitter in this equipment is guaranteed to meet federal communications commission acceptance over the operating temperature range. Modifications not expressly approved by Garmin could invalidate the license and make it unlawful to operate the equipment.

1.9 Certification

The conditions and tests required for TSO approval of this article are minimum performance standards. It is the responsibility of those installing this article either on or within a specific type or class of aircraft to determine that the aircraft installation conditions are within the TSO standards. The article may be installed only if performed under 14 CFR Part 43 or the applicable airworthiness requirements.

It is the installer's responsibility to ensure the ADS-B Out system is compliant with AC 20-165 and to ensure compatibility between the GTX 23 and the ADS-B Out position source equipment. See Garmin ADS-B Out Compatible Equipment (190-01533-00) for compatible equipment shown to be eligible for 14 CFR 91.227-compliant installations in accordance with AC 20-165.

1.9.1 GTX 23 TSO/ETSO/RTCA/ICAO Compliance

Table 1-5 TSO/ETSO/RTCA/ICAO Compliance

Function	Performance Standard (TSO/ETSO/RTCA/EUROCAE)	Category	Applicable LRU SW Part Numbers
Air Traffic Control Radar Beacon System/Mode Select (ATCRBS/MODE S) Airborne Equipment	TSO-C112	Class 2A	All 006-B1417-00
Traffic Information Service (TIS)	RTCA DO-239	-	
Air Traffic Control Radar Beacon System/Mode Select (ATCRBS/MODE S) Airborne Equipment	ETSO-2C112b	2C112b Class 1 Level 2es	
Extended Squitter Automatic Dependent Surveillance – Broadcast (ADS-B) and Traffic Information Services – Broadcast (TIS-B)	TSO-C166a (See Note 2) ETSO-C166a (See Note 2)	B0 (non-diversity) B1 (diversity)	006-B1417-00 Rev. A (v6.20)
	TSO-C166b (see Note 3)	B1S (non-diversity) B1 (diversity)	All 006-B1417-00 Rev. () except 006-B1417-00 Rev. A (v6.20)
Enhanced Surveillance	ICAO Annex 10, Amendment 77 Tables: 2-64, 2-80, 2-96 (See Note 1)	-	All 006-B1417-00
RTCA DO-178B Compliance	DO-178B	Level C	
RTCA DO-254 Compliance	DO-254	Level C	

Note 1: Complies with ICAO Annex 10, Amendment 77 Tables: 2-64, 2-80, 2-96 functionality only when the Enhanced Surveillance function is enabled during configuration ([Section 3.8.1](#)).

Note 2: Complies with TSO-166a/ETSO-166a functionality only when the ADS-B function is enabled during configuration ([Section 3.8.1](#)).

Note 3: Complies with TSO-C166b functionality only when the Extended Squitter function is enabled during configuraton ([Section 3.8.1](#)).

1.9.2 TSO/ETSO Deviations

Table 1-6 TSO/ETSO Deviations

TSO/ETSO	Deviation
TSO-C112	1. Garmin was granted a deviation from TSO-C112 to use RTCA DO-178B instead of RTCA DO-178A.
	2. Garmin was granted a deviation from TSO-C112 to use RTCA DO-160D instead of RTCA DO-160B.
	3. Garmin was granted a deviation from TSO-C112 to use RTCA DO-181C instead of RTCA DO-181.
	4. Garmin was granted a deviation from DO-160D, section 20.3.d.
	5. Garmin was granted a deviation from DO-181C section 2.2.16.2.6.2 to not provide Mode-S Extended Squitter for an ADS-B system (for non-ES transponders only).
ETSO-2C112b	1. Garmin was granted a deviation from DO-160D, section 20.3.d.
	2. Garmin was granted a deviation from ED-73B, section 1.4.2.2 to mark the equipment's functional level on the chassis in a location not visible when the transponder is mounted in the aircraft.
TSO-C166a	1. Garmin was granted a deviation from TSO-C166a to use RTCA DO-160D instead of RTCA DO-160E.
	2. Garmin was granted a deviation from TSO-C166a to place relevant TSO marking information within the installation manual, rather than on the equipment.
ETSO-C166a	1. Garmin was granted a deviation from ETSO-C166a to use RTCA/DO-160D instead of RTCA/DO-160E as the standard for Environmental Conditions and Test Procedures for Airborne Equipment.
	2. Garmin was granted a deviation from ETSO-C166a, section 4.1 and 4.2 to reference the installation manual for the equipment's ETSO compliance and class for this ETSO.
TSO-C166b	1. Garmin was granted a deviation from TSO-C166b to meet the transponder function requirements of RTCA DO-181C instead of RTCA DO-181D.
	2. Garmin was granted a deviation from TSO-C166b section 4.b to not mark the TSO number on the unit.
	3. Garmin was granted a deviation from TSO-C166b section 4.c to reference the installation manual for granted TSO deviations.
	4. Garmin was granted a deviation from TSO-C166b section 4.e to reference the installation manual for equipment class.

1.10 Operating Instructions

The GTX 23 is a remote-mount LRU with no user controls or indicators. All user interface is accomplished through a compatible display device. Although different displays will handle the transponder interface differently, all will typically have the following user inputs:

Mode Selection:

1. Standby Mode: In Standby Mode, the GTX 23 will not reply to interrogations.
2. ON Mode: In ON mode, the GTX 23 will generate Mode A and Mode S replies, but Mode C altitude reporting is inhibited.
3. Altitude Mode: In Altitude Mode, Mode C altitude reporting is enabled.

Code Selection:

1. Entering a Code: A total of 4096 discrete identification codes can be entered.
2. VFR Code: Selecting VFR changes the Code to the pre-programmed VFR code.

Ident Function:

Selecting the Ident function sends an ID indication to ATC for 18 seconds. This ID indication distinguishes your transponder from all others on the air traffic controller's radar screen.



NOTE

For detailed operating instructions, refer to the pilot's guide for the equipment that provides the GTX 23 user interface. The G3X Pilot's guide (190-01115-00) provides information for operating a GTX 23 in a G3X system.

1.11 Reference Documents

The following publications are sources of additional information for installing the GTX 23. Before installing the unit, the technician should read all relevant referenced materials along with this manual.

Table 1-7 Reference Documents

Part Number	Document
190-01115-01	G3X Installation Manual

2 INSTALLATION OVERVIEW

2.1 Introduction

This section provides hardware equipment information for installing the GTX 23 Mode S transponder, related hardware, and optional accessories. Installation of the GTX 23 should follow the data detailed in this manual. Cabling is fabricated by the installing agency to fit each particular aircraft. The guidance of FAA advisory circulars AC 43.13-1B and AC 43.13-2B, where applicable, may be found useful for making retro-fit installations that comply with FAA regulations.

Refer to Appendix D for rack drawings and dimensions.

2.2 Installation Materials

The GTX 23 is available as a single unit under the following part numbers:

Table 2-1 Installation Materials

Item	Catalog Part Number
GTX 23 w/ES, Unit Only, (011-02803-02)	010-01014-02
GTX 23 w/ES and Install Kit, (011-02803-02)	010-01014-03
GTX 23 w/ES, Standard, w/System Rack	010-01014-04

2.2.1 Equipment Available

Each of the following accessories is provided separately for the GTX 23 unit. The rack and the remainder of the accessories are required for installation.

Table 2-2 Equipment Available

Item	Garmin Catalog Part Number
Garmin Transponder Antenna kit**	010-10160-00
Connector Kit, GTX 23	011-01012-01
Back-plate Assembly, GTX 23, BNC*	011-00582-00
Back-plate Assembly, GTX 23, TNC*	011-00582-04
GTX 23 Modular Install Rack	115-00438-00
Or	
GTX 23 Stand-Alone Install Rack	115-00629-00

*Only one Backplate Assembly required, installer's choice of BNC or TNC connector.

**Note: A transponder antenna approved to TSO C66() or C74() that has been installed to meet the requirements of this manual may be used with the GTX 23.

2.2.2 Additional Equipment Required

The following installation accessories are required but not provided:

- Cables – The installer will supply all system cables including circuit breakers. Cable requirements and fabrication is detailed in Section 3 of this manual.
- Hardware – #6-32 x 100° Flathead SS Screw [(MS24693, AN507R or other approved fastener) (4 ea.)] for horizontal mounting of the remote stand-alone rack.
- Hardware – #8-32 Panhead Machine Screw [(MS35206, AN526 or other approved fastener) (4 ea.)] for vertical mounting of the remote stand-alone rack.
- Hardware – #6-32 x 100° Flathead SS Screw [(MS24693, AN507R or other approved fastener) (8 ea.)] for mounting of the remote modular rack.

2.3 Installation Considerations

2.3.1 Preservation of Previous Systems

It is the installer's responsibility to preserve the essential characteristic of the aircraft being modified with this equipment to be in accordance with the aircraft manufacturer's original design. This includes the preservation of multiple power buses, which reduces the probability of interrupting power to essential instruments and avionics.

2.3.2 Antenna Location Considerations

The antenna should be installed in accordance with AC 43.12-2A Chapter 3.

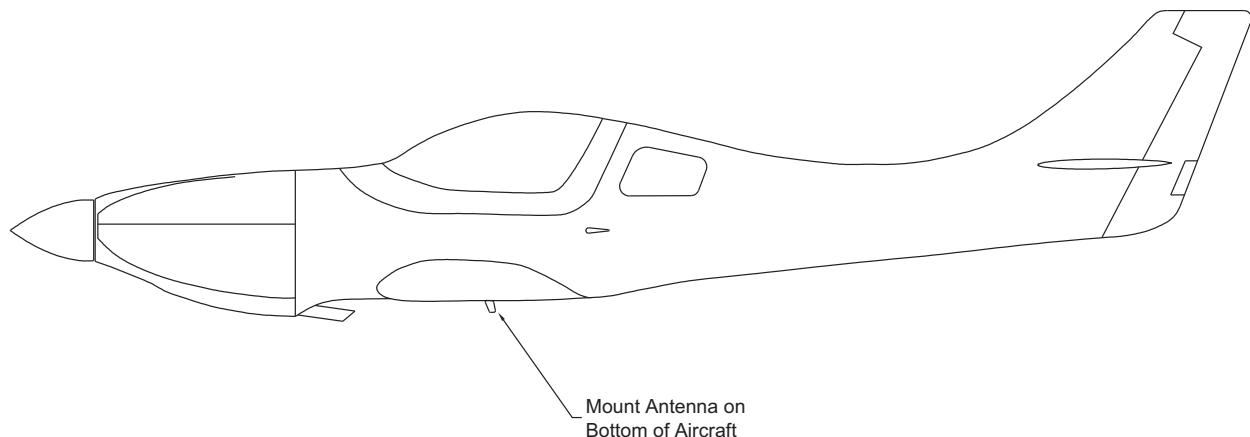

Figure 2-1. Antenna Installation Considerations

- a. The antenna (Garmin P/N 010-10160-00 or equivalent) should be mounted away from major protrusions, such as engine(s), propeller(s), and antenna masts. It should also be as far as practical from landing gear doors, access doors, or other openings that could shadow (block) the signal between the transponder antenna and ATC radar on TCAS.
- b. The antenna should be mounted vertically on the bottom of the aircraft (Figure 2-1).
- c. Antenna Separation: DME and TCAS receive signals in the same frequency range that aviation transponders transmit at, so their antennas should be separated from the transponder antenna by as much as feasible. Six feet of separation is a guideline. Radar altimeters (should one be installed on an aircraft with a GTX 23) also have some potential to receive interference from a transponder (the transponders' fourth harmonic), so it is good practice to separate transponder and radar altimeter antennas by as much as practical also. Avoid mounting the antenna within three feet of the ADF sense antenna or any other communication antenna.
- d. To prevent RF interference, the antenna must be physically mounted a minimum distance of three feet from the GTX 23.



NOTE

If the antenna is being installed on a composite aircraft, sufficient ground plane material must be added. Conductive wire mesh, radials, or thin aluminum sheets embedded in the composite material provide the proper ground plane allowing the antenna gain pattern to be maximized for optimum transponder performance.

2.4 Cabling and Wiring

Refer to the interconnect examples in Appendix C for wire gauge guidance.

Ensure that routing of the wiring does not come in contact with sources of heat, RF or EMI interference. Check that there is ample space for the cabling and mating connectors. Avoid sharp bends in cabling and routing near aircraft control cables. It is also good practice to avoid routing cables near sharp edges because aircraft vibration might wear away the insulation on the wires, which will leave them exposed to moisture and potentially create arcing or intermittent short circuits.

The GTX 23 back-plate assembly utilizes a BNC-type (bayonet connection) coaxial connector.

The maximum attenuation at 1090 MHz between the unit and the antenna must not exceed 1.5 dB. This loss specification includes connector loss; for example, through a bulkhead connector. The following table lists examples of recommended antenna cable. One can determine the length of cable needed to connect the transponder to the antenna, and then use the table to look up a recommended cable manufacturer and part number that will meet the 1.5 dB loss spec. The table assumes a loss figure of 0.2 dB per connector. Note that any 50 Ω , double shielded coaxial cable assembly that meets airworthiness requirements and the 1.5 dB maximum loss figure (including connectors) may be used.

Table 2-3 Cable Specifications

Max. Length (feet – [m])	Insertion loss (dB/100ft)	Carlisle IT Type	MIL-C-17 Type	RG Type
6' 1.3" [1.86m]	18.0		M17/128- RG400	RG-400
7' 7.3" [2.32m]	14.45	3C142B		
9' 2.0" [2.79m]	12.00		M17/112- RG304	RG-304
12' 6.0" [3.81m]	8.80	311601	M17/127- RG393	RG-393
15' 5.4" [4.71m]	7.12	311501		
19' 9.4" [6.03m]	5.56	311201		
30' 3.6" [9.24m]	3.63	310801		
Supplier Information		Vendor: Carlisle Interconnect Technologies 100 Tensolite Drive St. Augustine, FL 32092 Tel: 800-458-9960 904-829-3447 Fax: 904-829-3447 www.carlisleit.com	See current issue of Qualified Products List QPL-17.	RG types are obsolete and are shown for reference only; replaced by M17 type numbers.

2.4.1 Cable Routing Considerations

After the cable assemblies are made and wiring installed to the rack back plate, route wiring bundle as appropriate. Use cable ties to secure the cable assemblies and coax to provide strain relief for the cable assemblies. When routing cables, observe the following precautions:

- All cable routing should be kept as short and as direct as practical.
- Avoid sharp bends to prevent insulation from being breached.
- Avoid routing close to sharp edges to prevent insulation from being breached due to vibration or handling the cable.
- Avoid routing cables near power sources (e.g., 400 Hz generators, trim motors, etc.) or near power for fluorescent lighting.
- Avoid routing antenna cables near DME, TCAS, radar altimeter, and ADF antenna cables (allow at least a 12-inch separation).

2.5 Cooling Air

Cooling air is generally not required. However, if the unit is located in a confined space or near a source of heat, cooling air is recommended for maximizing the life of the GTX 23. A 5/8 inch air fitting is provided on the rear of the backplate for the purpose of admitting cooling air. If a form of forced air cooling is installed, make certain that rainwater or condensation cannot enter and be sprayed on the equipment.

2.6 GTX 23 Mounting Requirements

The GTX 23 mounting surface must be capable of providing structural support and electrical bond to the aircraft to minimize radiated EMI and provide protection from High-Intensity Radiation Fields (HIRF). The GTX 23 can be mounted using either a modular rack or a stand-alone rack. Ensure that the GTX 23 chassis has a ground path to the airframe by having at least one rack mounting screw in contact with the airframe.

The racks can be installed in a variety of locations, such as the electronics bay, under a seat or on an avionics shelf behind the rear baggage area. Refer to Figure 2-4 for suggested locations. The racks should be mounted to a surface known to have sufficient structural integrity to withstand additional inertia forces imposed by the GTX 23 unit, rack, and connectors (see Section 1.7.1 for weight information). If it is necessary to build a shelf or bracket to mount the GTX 23 racks, or it is not certain that the chosen location is of sufficient structural integrity, refer to Appendix A for validation of rack mounting structures and determining static load capability. Leave sufficient clearance between the GTX 23 and any obstruction. Consider installing the rack in accordance with AC 43.13-2B Chapter 2 “Communication, Navigation, and Emergency Locator Transmitter System Installations”.

2.6.1 Stand-alone Rack Considerations

Figures 2-2, D-1, and D-2 show the GTX 23 remote-mounted stand-alone rack. Figure D-1 gives the stand-alone rack dimensions for the GTX 23. The rack can be mounted vertically using four 8-32 pan head screws (MS35206, AN526 or other approved fastener). It can also be mounted horizontally using four 6-32 100° counter-sunk flathead screws (MS24693, AN507R or other approved fastener). If more water-resistance is desired, the rack should be installed in the upright vertical orientation only, otherwise, the rack may be mounted in either vertical or horizontal orientation.

2.6.2 Modular Rack Considerations

Figures 2-3, D-3, and D-4 show the GTX 23 remote-mounted modular rack. Figure D-3 gives the modular rack dimensions for the GTX 23. The modular rack can be mounted in any orientation and must be secured to the airframe using a minimum of eight 6-32 100° counter-sunk flathead screws (MS24693, AN507R or other approved fastener), two per position as indicated in Figure D-4.

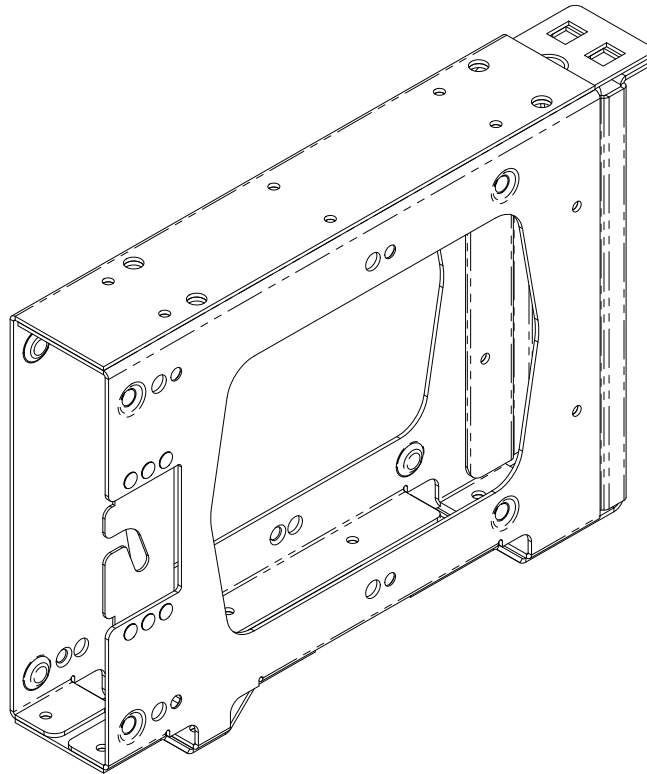

Figure 2-2. GTX 23 Stand-Alone Rack (115-00629-00)

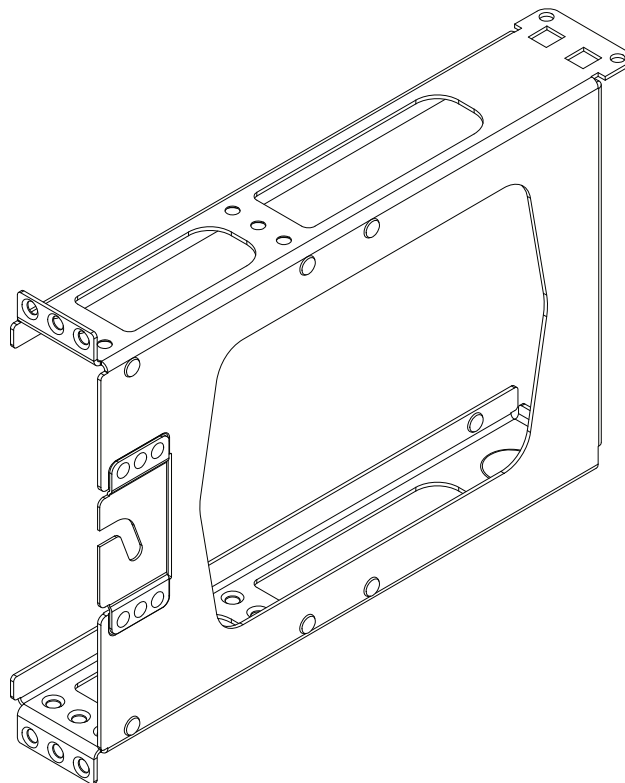

Figure 2-3. GTX 23 Modular Rack (115-00438-00)

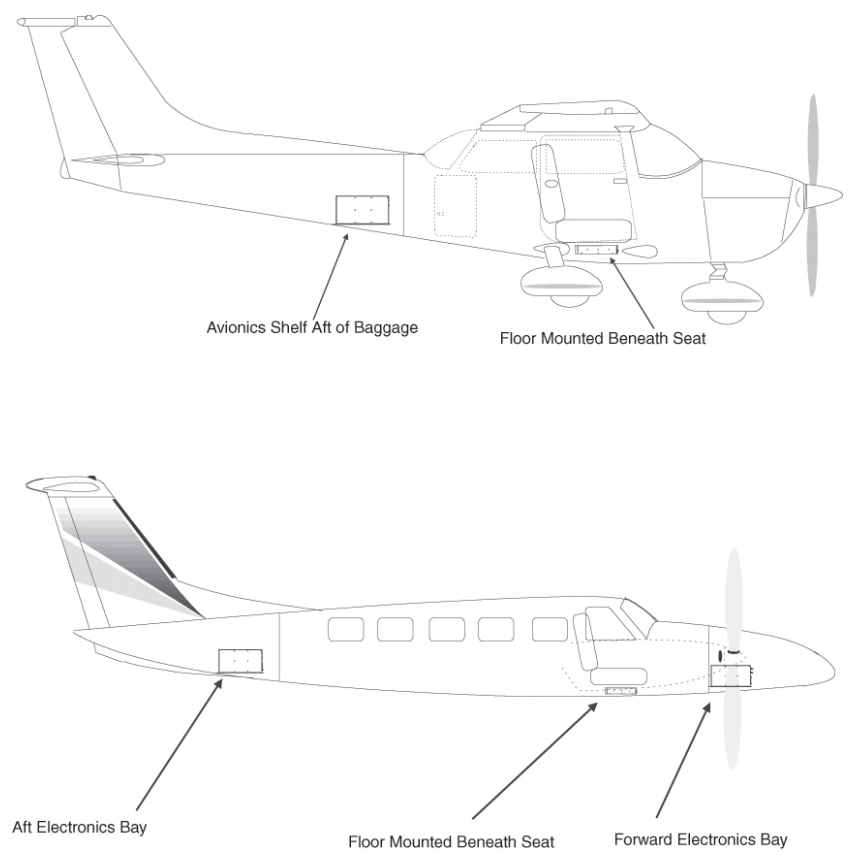

Figure 2-4. GTX 23 Stand-Alone Rack, Suggested Mounting Locations

3 INSTALLATION PROCEDURE

3.1 Unpacking Unit

Carefully unpack the equipment and make a visual inspection of the unit for evidence of damage incurred during shipment. If the unit is damaged, notify the carrier and file a claim. To justify a claim, save the original shipping container and all packing materials. Do not return the unit to Garmin until the carrier has authorized the claim.

Retain the original shipping containers for storage. If the original containers are not available, a separate cardboard container should be prepared that is large enough to accommodate sufficient packing material to prevent movement.

3.2 Wiring Harness Installation

Allow adequate space for installation of cables and connectors. The installer shall supply and fabricate all cables. All electrical connections to the GTX 23 are made through one 62-pin D-subminiature connector. Section 4 defines the electrical characteristics of all input and output signals. Required connectors and associated hardware are supplied with the connector kit.

See Appendix C for examples of interconnect wiring diagrams.



CAUTION

Check wiring connections for errors before inserting the GTX 23 into the rack. Incorrect wiring could cause internal component damage.

3.3 Electrical Connections

All electrical connections, except for the antenna and shield ground, are made through a single 62 pin D-subminiature connector (see Figure 4-1). Table 4-1 lists the electrical connections of all input and output signals. See Appendix C for interconnect wiring diagrams and cable requirements for each signal. Required connector and associated hardware are supplied in the connector kit (P/N 011-01012-01).



CAUTION

Check wiring connections for errors before inserting the GTX 23 into the rack. Incorrect wiring could cause internal component damage.

Table 3-1 Pin Contact Part Numbers (High Density)

Manufacturer*	62 pin connector (P2301)	
	18-20 AWG (Power Only)	22-28 AWG
Garmin P/N	336-00044-00	336-00021-00
Military P/N	N/A	M39029/58-360

*Non-Garmin part numbers shown are not maintained by Garmin and consequently are subject to change without notice.

Table 3-2 Recommended Crimp Tools (High Density)

Manufacturer (note 1)	Hand Crimp- ing Tool	18-20 AWG		22-28 AWG	
		Positioner	Insertion/ Extraction Tool (note 2)	Positioner	Insertion/ Extraction Tool
Military P/N	M22520/2-01	N/A	M81969/1-04	M22520/2-09	M81969/1-04
Positronic	9507-0	9502-11	M81969/1-04	9502-4	M81969/1-04
AMP	601966-1	N/A	91067-1	601966-6	91067-1
Daniels	AFM8	K774	M81969/1-04	K42	M81969/1-04
Astro	615717	N/A	M81969/1-04	615725	M81969/1-04

1) Non-Garmin part numbers shown are not maintained by Garmin and consequently are subject to change without notice.

2) Extracting the #18 or #20 contact requires that the expanded wire barrel be cut off from the contact. It may also be necessary to push the pin out from the face of the connector when using an extractor due to the absence of the wire. A new contact must be used when reassembling the connector.

3.4 Backshell Assembly

The GTX 23 connector kit includes one Garmin backshell assembly. Garmin's backshells give the installer the ability to quickly and easily terminate shield grounds at the backshell housing.

Refer to Appendix B for Shield Block Installation Instructions.

3.5 Weight and Balance

Weight and balance computation is required after the installation of the GTX 23. Follow the guidelines as established in AC 43.13-1B, Chapter 10, Section 2. Make appropriate entries in the equipment list indicating items added, removed or relocated along with the date accomplished. Include your name and certificate number in the aircraft records. Section 1.7.1 identifies the weight of the new GTX 23 equipment and the drawings in Appendix D shows the center of gravity.

3.6 Electrical Load Analysis

An electrical load analysis should be completed on each aircraft prior to installation in accordance with AC43.13-1B, Chapter 11. Use the following values for computation:

Table 3-3 Unit Power Loads

GTX 23 Input	14 Vdc		28 Vdc	
	Typical	Max.	Typical	Max.
GTX 23 Main Power	1.6 A	3.1 A	0.85 A	1.6 A

3.7 Final Installation

For final installation and assembly, refer to the outline and installation drawings shown in Appendix D of this manual.

- a. Assemble the connector backshell as described in Appendix B.
- b. Attach the connector to the rear plate using the screws provided in the connector kit.
- c. Mount the unit rack to a mounting location that considers the mounting requirements in Section 2.6.
- d. Assemble the rear plate into the GTX 23 unit rack using screws provided with the rear plate.
- e. Insert the GTX 23 into the rack, noting proper orientation as shown on the installation drawing in Appendix D.



CAUTION

Do not use excessive force when inserting the GTX 23 into the rack. This may cause damage to occur to the connectors, unit, and/or unit rack. If heavy resistance is felt during installation, stop! Remove the GTX 23 and identify the source of resistance.

- f. Lock the GTX 23 in place using the lever-locking handle. Fasten the handle to the GTX 23 body using the provided Phillips screw.



CAUTION

Start the handle screw into the hole carefully, to avoid cross-threading. Do not apply torque in excess of 14 in-lbs to the handle screw. The application of torque exceeding 14 in-lbs to the screw will damage the LRU case and/or retaining hardware.

3.8 Post Installation Configuration and Checkout



NOTE

The GTX 23 Mode S Transponder will not provide valid outputs until the aircraft post installation configuration procedures are completed.

3.8.1 Configuration

Since the GTX 23 is remote mount, it is installed with other equipment that provides a user interface. For information on configuring the GTX 23, please see the installation manual for the equipment that provides the user interface for the GTX 23. The G3X install manual (190-01115-01) is an example of a manual that provides information for how to configure a GTX 23 in a G3X system.

3.8.2 Interference Check

Turn on and verify operation of all avionics equipment except GTX 23. Then power the GTX 23 on, and verify there is no interference with any other equipment in the aircraft. The operation/performance checks should be made with all other avionics turned on. Verify that there is no interference during any mode of transponder operation.

3.8.3 Performance (Ramp) Test



CAUTION

If the unit is removed from the aircraft and operated, always connect J2302 to an antenna or a 50 Ω , 5-Watt load. The GTX 23 transmits Mode S acquisition squitters about once per second whether interrogations are received or not. The unit may become damaged if J2302 is not connected to a 50 Ω , 5-Watt load when the unit squitters,

Installations require verification of proper operation of the transponder by testing as specified in Appendix F of 14 CFR, Part 43, to AC 43-6B, and/or other appropriate regulations. The test is typically done as a ramp test using a transponder ramp test set, such as the TIC TR-220, IFR ATC-601 or other suitable Mode S transponder test set. The ramp test includes checks as follows:

Reference Part 43 Appendix F:

- a. Reply Frequency
- b. Suppression
- c. Receiver Sensitivity
- d. Reply RF Output Power
- e. Mode S Diversity Channel Isolation (if applicable)
- f. Mode S Address
- g. Mode S Formats
- h. Mode S All-Call
- i. ATCRBS –Only All Call
- j. Squitter

Reference AC 43-6B and 14 CFR Part 43, Appendix E (c):

- a. Altitude Reporting

3.9 Continued Airworthiness

Installations are required to test according to Title 14 CFR §§ 91.411 and 91.413 as well as Part 43 Appendix F. Otherwise, maintenance of the GTX 23 is 'on condition' only.

4 SYSTEM INTERCONNECTS

4.1 Pin Function List

4.1.1 P2301

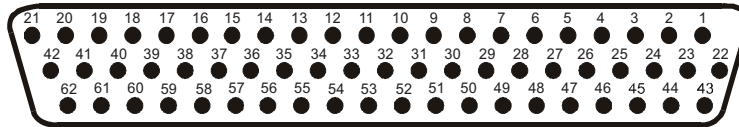

Figure 4-1. J2301 Connector

Table 4-1 P2301 Pin Assignments

Pin	Pin Name	I/O
1	NOT USED	--
2	NOT USED	--
3	NOT USED	--
4	NOT USED	--
5	NOT USED	--
6	NOT USED	--
7	NOT USED	--
8	NOT USED	--
9	NOT USED	--
10	NOT USED	--
11	NOT USED	--
12	EXTERNAL IDENT SELECT*	In
13	EXTERNAL STANDBY SELECT*	In
14	NOT USED	--
15	NOT USED	--
16	NOT USED	--
17	NOT USED	--
18	NOT USED	--
19	NOT USED	--
20	NOT USED	--
21	AIRCRAFT POWER 1	In
22	RS-232 IN 1	In
23	RS-232 OUT 1	Out
24	RS-232 IN 2	In
25	RS-232 OUT 2	Out
26	NOT USED	--
27	NOT USED	--
28	ARINC 429 OUT 2 B	Out
29	NOT USED	--
30	ARINC 429 OUT 2 A	Out

*Denotes active low (ground to activate)

Table 4-1 P2301 Pin Assignments

Pin	Pin Name	I/O
31	MUTUAL SUPPRESSION I/O	I/O
32	NOT USED	--
33	NOT USED	--
34	ARINC 429 OUT 1 B	Out
35	NOT USED	--
36	NOT USED	--
37	ARINC 429 OUT 1 A	Out
38	NOT USED	--
39	POWER GROUND	--
40	NOT USED	--
41	NOT USED	--
42	AIRCRAFT POWER 1	In
43	RS-232 GROUND	--
44	NOT USED	--
45	NOT USED	In
46	TIS CONNECT SELECT*	In
47	NOT USED	--
48	NOT USED	--
49	NOT USED	--
50	RS-232 GROUND 2	--
51	NOT USED	--
52	NOT USED	--
53	NOT USED	--
54	NOT USED	--
55	NOT USED	--
56	AIRCRAFT POWER 2	In
57	NOT USED	--
58	POWER GROUND	--
59	NOT USED	--
60	AIRCRAFT POWER 2	In
61	NOT USED	--
62	NOT USED	--

*Denotes active low (ground to activate)

4.1.2 Aircraft Power

Power input requirements are listed in the following tables. The power input pins accept 14/28 Vdc. Refer to Figure C-1 and C-2 for power interconnections.

Table 4-2 Aircraft Power

Pin Name	Connector	Pin	I/O
AIRCRAFT POWER 1	P2301	21	In
AIRCRAFT POWER 1	P2301	42	In
AIRCRAFT POWER 2	P2301	56	In
AIRCRAFT POWER 2	P2301	60	In
POWER GROUND	P2301	39	--
POWER GROUND	P2301	58	--

4.2 Discrete Functions

4.2.1 Discrete Outputs

External suppression should be connected if a DME or TCAS is installed in the aircraft avionics system. The GTX 23 suppression I/O pulses may not be compatible with all models of DME or TCAS. Known incompatible DME units include the Bendix/King KN 62, KN 64 and KNS 80. These models have an output-only suppression port and can be damaged by the GTX 23 mutual suppression output. In this case, do not connect the GTX 23's suppression pin to the incompatible unit's suppression pin; however, do connect the GTX 23's suppression pin to any other compatible unit's suppression pin.

Table 4-3 Discrete Outputs

Pin Name	Connector	Pin	I/O
EXTERNAL SUPPRESSION I/O (TXP/DME)	P2301	31	I/O

4.2.2 Discrete Inputs

Sink current is internally limited to 200 uA max for a grounded input

EXTERNAL IDENT SELECT (remote IDENT) is a momentary input. When grounded, it activates the IDENT pulse for 18 seconds in Mode A replies.

EXTERNAL STANDBY SELECT (remote STANDBY) is not a momentary input. When EXTERNAL STANDBY SELECT is grounded, the GTX 23 operates in standby mode. In this mode, the transponder will not squitter or reply to interrogations.

TIS CONNECT SELECT is a momentary input. When grounded, it toggles whether TIS is in standby or operating.

Table 4-4 Discrete Inputs

Pin Name	Connector	Pin	I/O
EXTERNAL IDENT SELECT*	P2301	12	In
EXTERNAL STANDBY SELECT*	P2301	13	In
TIS CONNECT SELECT	P2301	46	In

*Inactive State: $10 \leq V_{in} \leq 33V_{dc}$ or $R_{in} \geq 100k\Omega$, Active State: $V_{in} \leq 1.9V_{dc}$ with $\geq 75 \mu A$ sink current, or $R_{in} \leq 375\Omega$

4.3 Serial Data Electrical Characteristics

4.3.1 RS-232 Input/Output

RS-232 input #1 is used to receive pressure altitude control commands. RS-232 output #1 provides unit status and TIS data. RS-232 #1 input and output are also used for software upgrades.

For installations that enable ADS-B, RS-232 input #2 should be connected to a GNS 400W/500W-series WAAS enabled unit or a GTN 6XX/7XX series unit. This connection provides the GTX 23 with GPS data for ADS-B. The RS-232 output #2 is unused on the GTX 23.

The RS-232 outputs conform to EIA Standard RS-232C with an output voltage swing of at least ± 5 V when driving a standard RS-232 load. Refer to figures in Appendix C for the RS-232 serial data interconnect.

Table 4-5 RS-232 Input/Output

Pin Name	Connector	Pin	I/O
RS-232 OUT 1	P2301	23	Out
RS-232 GROUND 1	P2301	43	--
RS-232 IN 1	P2301	22	In
RS-232 OUT 2	P2301	25	Out
RS-232 IN 2	P2301	24	In
RS-232 GROUND 2	P2301	50	--

4.3.2 ARINC 429 Input/Output

The ARINC 429 outputs conform to ARINC 429 electrical specifications when loaded with up to five standard ARINC 429 receivers.

Table 4-6 ARINC 429 Input/Output

Pin Name	Connector	Pin	I/O
ARINC 429 OUT 1A	P2301	37	Out
ARINC 429 OUT 1B	P2301	34	Out
ARINC 429 OUT 2A	P2301	30	Out
ARINC 429 OUT 2B	P2301	28	Out
SIGNAL GROUND	P2301	51	--
SIGNAL GROUND	P2301	58	--

4.4 RS-232 Input/Output, Software Update Connections

GTX 23 software is updated using the RS-232 #1 interface. When wiring the RS-232 #1 interface to the rest of the system, it may be useful to splice in a pigtail connector that could be plugged into a laptop computer. Also when wiring, consider that the GTX 23 must be turned on (during software update) and the other avionic equipment attached to the RS-232 #1 interface (e.g. GSU or GDU) must be turned off. Instead of turning the other avionic equipment off, a relay can be installed that disconnects the avionic equipment and connects the laptop to the GTX 23. This connector may be useful for updating software to comply with new ADS-B regulation.

The connector can be mounted anywhere convenient for access, such as under the instrument panel, on a remote avionics shelf next to the unit, or in the instrument panel itself. Label the connector “For Software Update”. Do not include the Test Mode Select switch in the aircraft. See Figure 4-2 for software update connections.



CAUTION

If the unit is removed from the aircraft and operated, always connect J2302 to an antenna or a 50 Ω, 5-Watt load (Figure 4-2). The GTX 23 transmits Mode S acquisition squitter replies about once per second whether interrogations are received or not. The unit may become damaged if J2302 is not connected to a 50 Ω, 5-Watt load when the unit transmits.

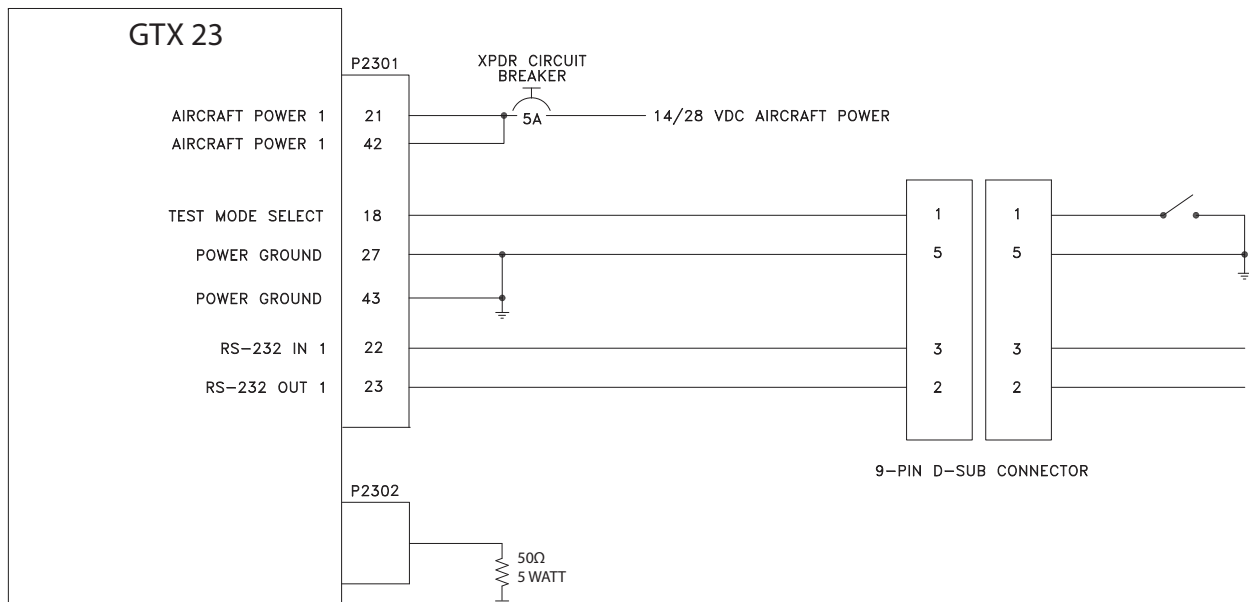

Figure 4-2. GTX 23 Software Update Connections

APPENDIX A CONSTRUCTION AND VALIDATION OF STRUCTURES

A.1 Static Test Loading

This appendix includes information necessary for testing load-carrying capabilities of equipment mounting structures, such as shelves, mounting plates and mounting brackets, used to mount the GTX 23 remote mounting racks.

Baggage compartments and cabins or cockpit floors are good mounting platforms providing the floor attachments meet the strength requirements. If support racks, brackets or shelves need to be fabricated, consider fabricating and attaching them to the aircraft structure in accordance with the methods outlined in AC 43.13-2B Chapter 2. After the structure is installed, consider testing it as outlined in AC 43.13-2B Chapter 1 to verify that it is capable of supporting the required loads.

The GTX 23 installation must be capable of withstanding the Ultimate Load Factors listed in Table A-1 for at least 3 seconds in each direction specified without damage or permanent deformation. Note that these required loads differ somewhat from those normally required for equipment installations.

Since the combined weight of the GTX 23 and its equipment mounting rack and connector is 4.3 lbs, the static loads which must be applied (Load Factor x 4.3 lbs.) will be as follows:

Table A-1 Static Test Load

Direction of Force	Load Factor	Static Test Load (Load Factor x GTX 23 weight)
DOWNWARD	6.6 G	(6.6 x 4.3) = 28.4 lbs
UPWARD	6.0 G	(6.0 x 4.3) = 25.8 lbs
SIDEWARD	4.5 G	(4.5 x 4.3) = 19.4 lbs
FORWARD	18.0 G	(18.0 x 4.3) = 77.4 lbs

A.2 Determining Static Load Capability

A recommended method of determining the static load capability is as follows:

1. Mark and drill the holes where the GTX 23 equipment rack will be mounted.
2. Install four 8-32 machine screws (MS35206, AN526 or other approved fastener) in the four holes which will be used to mount the GTX 23 equipment rack using washers, nuts and nutplates to mount the equipment rack to the mounting surface. Note that some means of locking fastener must be used, e.g. either lock nuts or steel nuts with lock washers.
3. For testing downward loading, place shot bags or other suitable weights totaling 28.4 pounds within the footprint outlined by the four screw holes (assuming the mounting surface is horizontal) or use a calibrated force gauge at the location of the center of gravity when the unit is mounted.
4. Verify there is no damage or permanent deformation of the structure after 3 seconds.
5. Fasten a 36 inch loop of suitable material such as fishing line, braided wire, or other similar material having a breaking strength of at least 100 lbs., diagonally between two of the screws. Then fasten another loop diagonally between the other two screws, adjusting the length of the loop so it exactly matches the first.
6. Hook a calibrated force gauge through both loops and apply a sustained pull for at least 3 seconds in each of the other three directions (upward, sideward and forward) at the above calculated forces (i.e. 25.8 lb. upward, 19.4 lb. sideward and 77.4 lb. forward).

7. Examine the support structure carefully. If there has been damage or permanent deformation, the structure is not suitable and must be replaced with one that is strong enough to withstand the test loads. Examine all aircraft stringers, bulkheads and skin surfaces, which may have direct or indirect contact with the fabricated shelf. If it is determined that no damage or permanent deformation has occurred, the structure is of sufficient strength and the GTX 23 equipment rack may be permanently mounted on it.

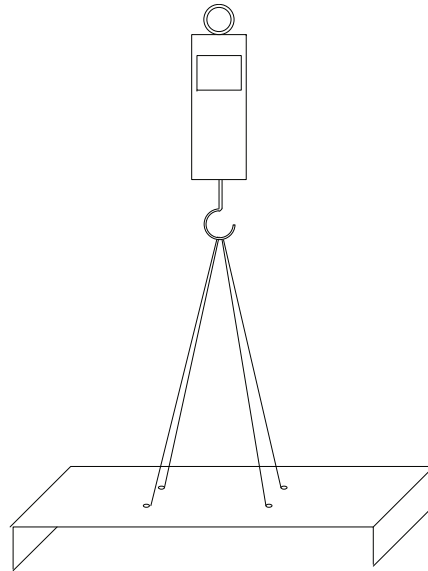

Figure A-1. Upward static Load Test

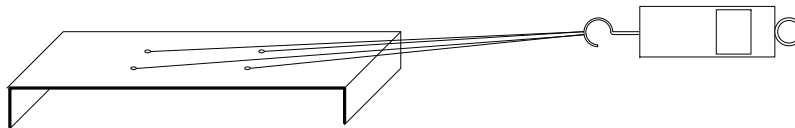

Figure A-2. Forward Static Load Test

APPENDIX B SHIELD BLOCK INSTALLATION INSTRUCTIONS

B.1 Shield Block Installation Parts



CAUTION

Disclaimer: This instruction manual assumes skill and knowledge of aircraft harness fabrication techniques. DO NOT PERFORM THIS INSTALLATION IF YOU ARE UNQUALIFIED.

Tables B-1 & B-2 list parts needed to install a Shield Block in a D-Sub connector. The Item Numbers listed in Tables B-1 & B-2 coincide with the Item Numbers in Figure B-1.

Table B-1 Parts Supplied for a Shield Block Installation (011-01012-01)

Item Number	Description	GPN or MIL spec
1	Cast Backshell Housing	125-00084-00
2	Shield Block	117-00147-01
3	Screw, 4-40x.250, FLHP 100, SS/P, Nylon	211-63234-08
8	Contacts	336-00021-00
14	Clamp	115-00499-03
15	Screw, 4-40x.375, PHP, SS/P, w/Nylon	211-60234-10
16	Backshell Cover	115-00500-03
17	Screw, 4-40x.187, FLHP100, SS/P, w/Nylon	211-63234-06
18	Connector, Hi Density D-Sub, 62 pin	330-00185-62

Table B-2 Parts Not Supplied for a Shield Block Installation (Figure B-1)

Item Number	Description	GPN or MIL spec
4	Multiple Conductor Shielded Cable (2-conductor shown in Figure B-1)	Refer to Installation Wiring Diagrams
5	Drain Wire Shield Termination, Solder Sleeve (method optional)	Parts used depend on method chosen
6	Braid, Flat (19-20 AWG equivalent, tinned plated copper strands 36 AWG, Circular Mil Area 1000 -1300)	Parts used depend on method chosen
7	Floating Shield Termination (method optional)	Parts used depend on method chosen
9	Ring terminal, #8, insulated, 18-22 AWG	MS25036-149
	Ring terminal, #8, insulated, 14-16 AWG	MS25036-153
	Ring terminal, #8, insulated, 10-12 AWG	MS25036-156
10	Screw, PHP, 8-32x.312", Stainless	MS51957-42
	Screw, PHP, 8-32x.312", Cad Plated Steel	MS35206-242
11	Split Washer, #8, (.045" compressed thickness) Stainless	MS35338-137
	Split Washer, #8, (.045" compressed thickness) Cad-plated steel	MS35338-42
12	Flat Washer, Stainless, #8, .032" thick, .174"ID, .375" OD	NAS1149CN832R
	Flat washer, Cad-plated Steel, #8, .032" thick, .174"ID, .375" OD	NAS1149FN832P
13	Silicon Fusion Tape	-



NOTE

In Figure B-1, "AR" denotes quantity "As Required" for the particular installation.

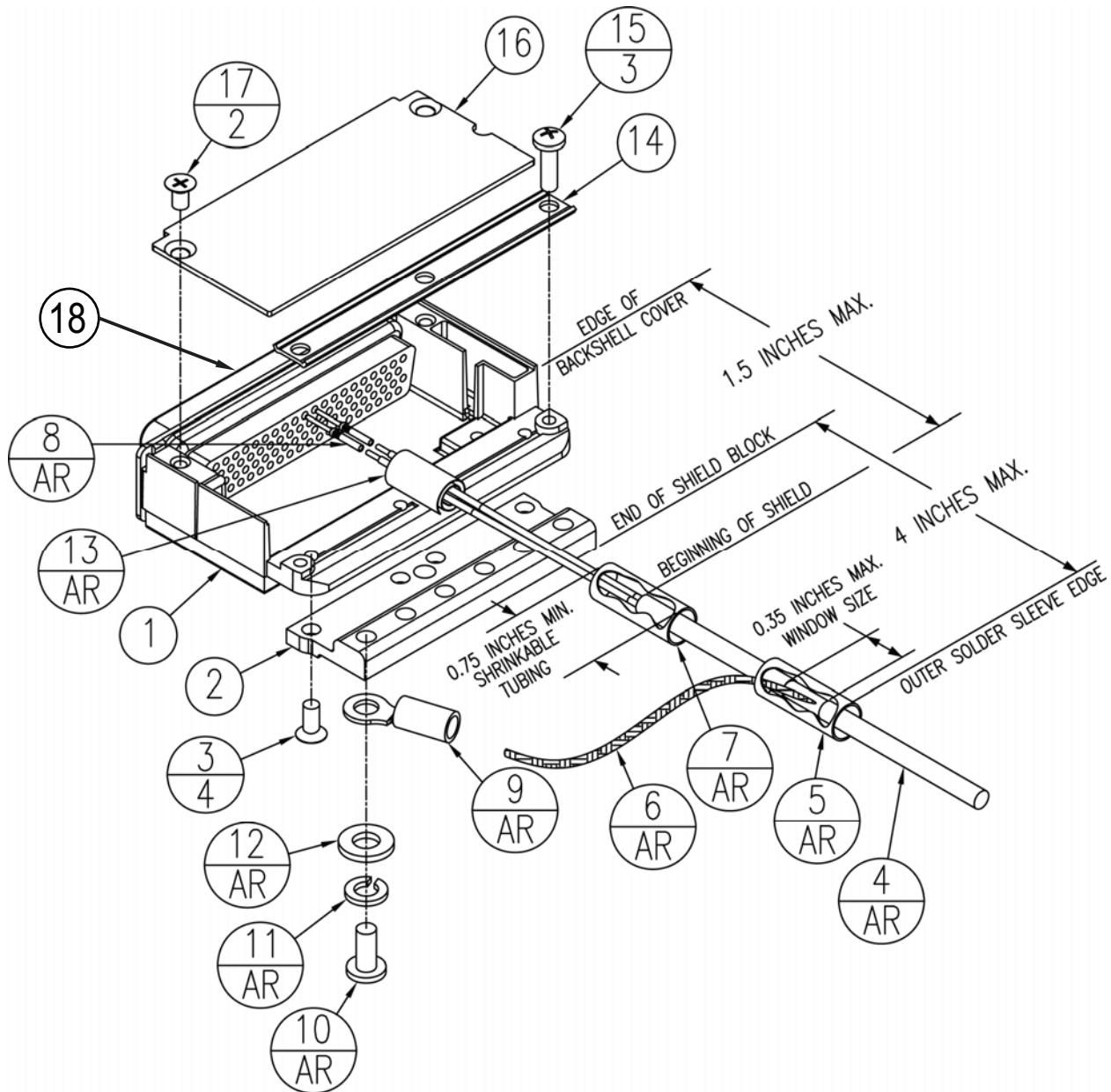

Figure B-1 Shield Block Installation (78 pin example)

B.2 Shield Termination Technique – Method A.1 (Standard)



NOTE

For the following steps please refer to Figure B-1.

1. Attach the Shield Block(s) (Item 2) to the backshell (Item 1) by inserting the flathead screws (Item 3) through the holes on the Shield Block and threading into the tapped holes on the backshell (Item 1) (see Figure B-1).

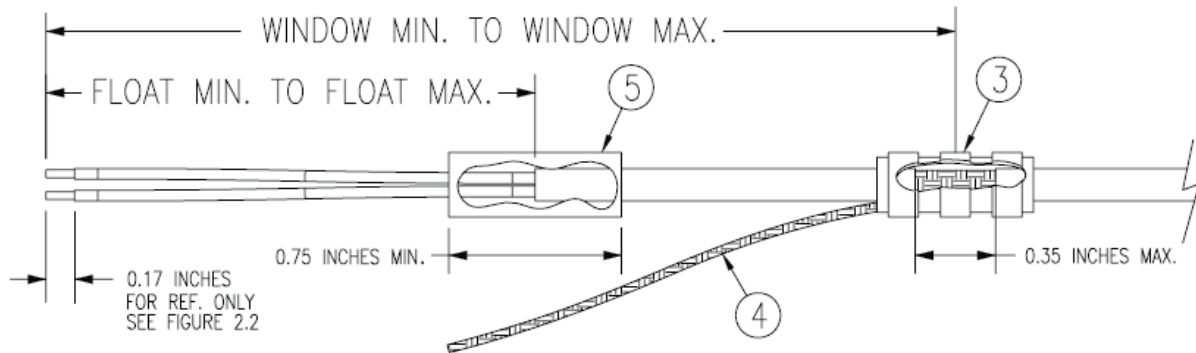

Figure B-2 Method A.1 for Shield Termination

Table B-3 Shielded Cable Preparations for Garmin Connectors

Backshell Size	Number of Pins Std/HD	Float Min (inches)	Float Max (inches)	Ideal Float (inches)	Window Min (inches)	Window Max (inches)	Ideal Window (inches)
1	9/15	1.25	2.25	1.75	2.75	5.25	4.25
2	15/26	1.5	2.5	2.0	3.0	5.5	4.5
3	25/44	1.5	2.5	2.0	3.0	5.5	4.5
4	37/62	1.5	2.5	2.0	3.0	5.5	4.5
5	50/78	1.5	2.5	2.0	3.0	5.5	4.5

2. At one end of a shielded cable (Item 4) measure a distance between “Window Min” to “Window Max” (Table B-6) and cut a window (max size 0.35”) in the jacket to expose the shield (Figure B-2). Use caution when cutting the jacket to avoid damaging the individual braids of the shield. When dealing with a densely populated connector with many cables, it may prove beneficial to stagger the windows throughout the “Window Min” to “Window Max” range. If staggering is not needed the “Ideal Window” length is recommended.

Suggested tools to accomplish the window cut:

- Coaxial Cable Stripper
- Thermal Stripper
- Sharp Razor Blade

3. Connect a Flat Braid (Item 6) to the shield exposed through the window of the prepared cable assembly (Item 4) from step 2. The Flat Braid should go out the front of the termination towards the connector. It is not permitted to exit the rear of the termination and loop back towards the connector (Figure B-2). Make this connection using an approved shield termination technique.



NOTE

FAA AC 43.13-1B Chapter 11, Section 8 (Wiring Installation Inspection Requirements) may be a helpful reference for termination techniques.

Preferred Method:

Slide a solder sleeve (Item 5) onto the prepared cable assembly (Item 4) and connect the Flat Braid (Item 6) to the shield using a heat gun approved for use with solder sleeves. It may prove beneficial to use a solder sleeve with a pre-installed Flat Braid versus having to cut a length of Flat Braid to be used. The chosen size of solder sleeve must accommodate both the number of conductors present in the cable and the Flat Braid (Item 6) to be attached.

Solder Sleeves with pre-installed Flat Braid

A preferred solder sleeve would be the Raychem S03 Series with the thermochromic temperature indicator (S03-02-R-9035-100, S03-03-R-9035-100, S03-04-R-9035-100). These solder sleeves come with a pre-installed braid and effectively take the place of Items 3 and 4. For detailed instructions on product use, reference Raychem installation procedure RCPS 100-70.

Raychem recommended heating tools:

- HL1802E
- AA-400 Super Heater
- CV-1981
- MiniRay
- IR-1759

Individual solder sleeves and Flat Braid

Solder Sleeves:

Reference the following MIL-Specs for solder sleeves.
(M83519/1-1, M83519/1-2, M83519/1-3, M83519/1-4, M83519/1-5)

Flat Braid:

If the preferred Raychem sleeves are not being used, the individual flat braid selected should conform to ASTM B33 for tinned copper and be made up of 36 AWG strands to form an approximately 19-20 AWG equivalent flat braid. A circular mil area range of 1000 to 1300 is required. The number of individual strands in each braid bundle is not specified (e.g. QQB575F36T062).



NOTE

Flat Braid as opposed to insulated wire is specified in order to allow continuing air worthiness by allowing for visual inspection of the conductor.

Secondary Method:

Solder a Flat Braid (Item 6) to the shield exposed through the window of the prepared cable assembly (Item 4). Ensure a solid electrical connection through the use of acceptable soldering practices. Use care to avoid applying excessive heat that burns through the insulation of the center conductors and shorts the shield to the signal wire. Slide a minimum 0.75 inches of Teflon heat shrinkable tubing (Item 5) onto the prepared wire assembly and shrink using a heat gun. The chosen size of heat shrinkage tubing must accommodate both the number of conductors present in the cable and the Flat Braid (Item 6) to be attached.

Teflon Heat Shrinkable Tubing:

Reference the following MIL-Spec for Teflon heat shrinkable tubing (M23053/5-X-Y).

- At the same end of the shielded cable (Item 4) and ahead of the previous shield termination, strip back “Float Min” to “Float Max” (Table B-2) length of jacket and shield to expose the insulated center conductors (Figure B-2). The “Ideal Float” length may be best to build optimally.

Preferred Method:

The jacket and shield should be cut off at the same point so no shield is exposed. Slide 0.75 inches minimum of Teflon heat shrinkable tubing (Item 7) onto the cable and use a heat gun to shrink the tubing. The chosen size of heat shrinkage tubing must accommodate the number of conductors present in the cable.

Secondary Method:

Leave a max 0.35 inches of shield extending past the jacket. Fold this 0.35 inches of shield back over the jacket. Slide a solder sleeve (Item 7) over the end of the cable and use a heat gun approved for solder sleeves to secure the connection. The chosen size of solder sleeve must accommodate the number of conductors present in the cable.

- Strip back approximately 0.17 inches of insulation from each wire of the shielded cable (Item 4) and crimp a contact (Item 8) to each conductor. It is the responsibility of the installer to determine the proper length of insulation to be removed. Wire must be visible in the inspection hole after crimping and the insulation must be 1/64 – 1/32 inches from the end of the contact as shown in Figure B-3.

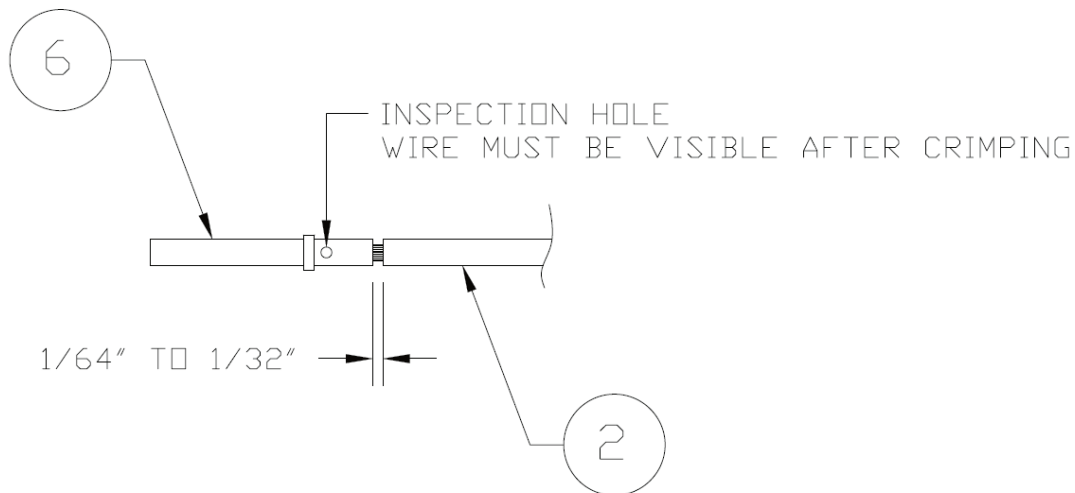

Figure B-3 Insulation/Contact Clearance

6. Insert newly crimped pins and wires into the appropriate connector housing location as specified by the installation wiring diagrams.
7. Cut the Flat Braid (Item 6) to a length that, with the addition of a ring terminal, will reach one of the tapped holes of the Shield Block (Item 2) (Figure B-1). An appropriate amount of excess length without looping should be given to the Flat Braid (Item 6) to allow it to freely move with the wire bundle.

**NOTE**

Position the window splice to accommodate a Flat Braid (Item 6) length of no more than 4 inches.

8. Guidelines for terminating the newly cutoff Flat Braid(s) (Item 6) with insulated ring terminals (Item 9):
 - Each tapped hole on the Jackscrew Backshell (Item 1) may accommodate only two ring terminals (Item 7).
 - It is preferred that only two Flat Braid(s) (Item 6) be terminated per ring terminal. Two Flat Braids per ring terminal will necessitate the use of a Ring terminal, #8, insulated, 14-16 AWG (MS25036-153).
 - If only a single Flat Braid is left or if only a single Flat Braid is needed for this connector a Ring terminal, #8, insulated, 18-22 AWG (MS25036-149) can accommodate this single Flat Braid.
 - If more braids exist for this connector than two per ring terminal, it is permissible to terminate three braids per ring terminal. This will necessitate the use of a Ring terminal, #8, insulated, 10-12 AWG (MS25036-156).
9. Repeat steps 2 through 8 as needed for the remaining shielded cables.
10. Terminate the ring terminals to the Jackscrew Backshell (Item 2) by placing items on the Pan Head Screw (Item 10) in the following order: Split Washer (Item 11), Flat Washer (Item 12) first Ring Terminal, second Ring Terminal (if needed) before finally inserting the screw into the tapped holes on the Jackscrew Backshell. Do not violate the guidelines presented in Step 8 regarding ring terminals.
11. It is recommended to wrap the cable bundle with Silicone Fusion Tape (Item 13) (GPN: 249-00114-00 or a similar version) at the point where the backshell clamp and cast housing will contact the cable bundle.

**NOTE**

Choosing to use this tape is the discretion of the installer.

12. Place the smooth side of the backshell clamp (Item 14) across the cable bundle and secure using the three screws (Item 15). Warning: Placing the grooved side of the clamp across the cable bundle may risk damage to wires.
13. Attach the cover (Item 16) to the backshell (Item 1) using the two screws (Item 17).

B.3 Shield Termination Technique - Method A.2 (Daisy Chain)

In rare situations where more braids need to be terminated for a connector than three per ring terminal it is allowable to daisy chain a maximum of two shields together before coming to the ring terminal (Figure B-4). All other restrictions and instructions for the shield termination technique set forth for Method A.1 are still applicable.



NOTE

The maximum length of the combined braids should be approximately 4 inches.

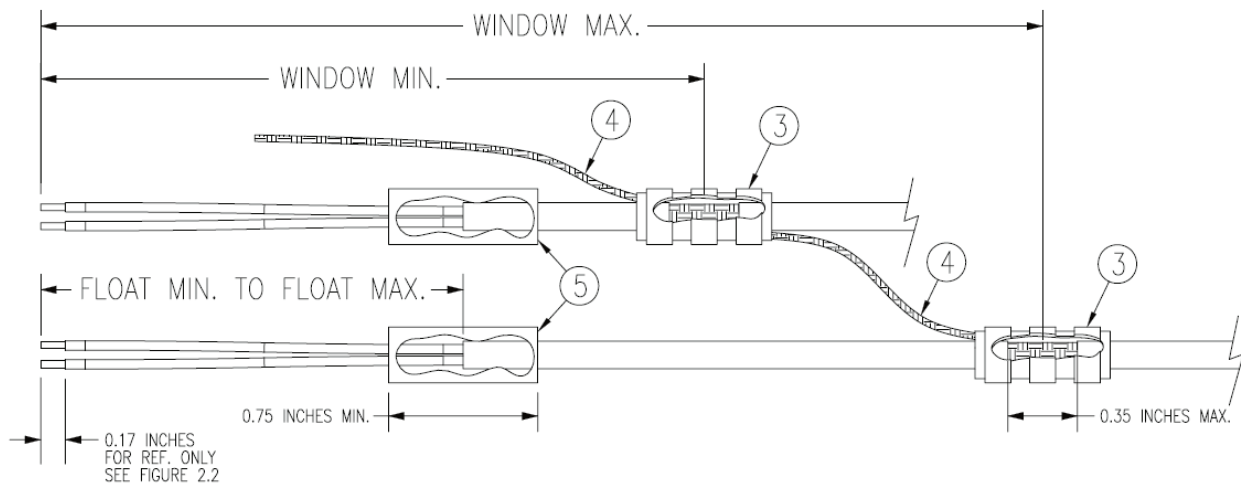

Figure B-4 Method A.2 (Daisy Chain) for Shield Termination

B.4 Shield Termination – Method B.1 (Quick Term)

If desired, the drain wire termination (Item 5) and the floating shield termination (Item 7) can be effectively combined into a “Quick Term”. This method eliminates the float in the cable insulation and moves the placement of the window which was described by the dimensions “Window Min” and “Window Max” from Method A.1. This technique is depicted in Figure B-5.



NOTE

The original purpose for separating the shield drain termination (Item 5) from the float termination (Item 7) in Method A.1 was to allow for a variety of lengths for the drain wires so that the shield drain terminations (Item 5) would not all “bunch up” in the harness and to eliminate loops in the drain wires. If Method B.1 is chosen, as described in this section, care must be taken to insure that all drain shield terminations can still be inspected. With connectors which require a large number of shield terminations it may be best to use Method A.1. This will allow the drain shield terminations (Item 5) a larger area to be dispersed across.

Using this method, the instructions from Section B.2 (Method A.1) are followed except that:

1. Step 2 is eliminated
2. Steps 3 and 4 are replaced by the following:

At the end of the shielded cable (Item 4), strip “Quick Term Min” to “Quick Term Max” (Table B-4) length of the jacket to expose the shield. Next trim the shield so that at most 0.35 inches remains extending beyond the insulating jacket. Fold this remaining shield back over the jacket.

Connect a Flat Braid (Item 6) to the folded back shield of the prepared cable assembly. The flat braid should go out the front of the termination towards the connector. It is not permitted to exit the rear of the termination and loop back towards the connector (Figure B-5). Make this connection using an approved shield termination technique.



NOTE

FAA AC 43.13-1B Chapter 11, Section 8 (Wiring Installation Inspection Requirements) may be a helpful reference for termination techniques.

Preferred Method:

Slide a solder sleeve (Item 5) onto the prepared cable assembly (Item 4) and connect the Flat Braid (Item 6) to the shield using a heat gun approved for use with solder sleeves. It may prove beneficial to use a solder sleeve with a pre-installed Flat Braid versus having to cut a length of Flat Braid to be used. The chosen size of solder sleeve must accommodate both the number of conductors present in the cable and the Flat Braid (Item 6) to be attached.



NOTE

Reference Section B.2 for recommended solder sleeves and flat braid. The same recommendations are applicable to this technique.

Secondary Method:

Solder a Flat Braid (Item 6) to the folded back shield on the prepared cable assembly (Item 4). Ensure a solid electrical connection through the use of acceptable soldering practices. Use care to avoid applying excessive heat that burns through the insulation of the center conductors and shorts the shield to the signal wire. Slide a minimum of 0.75 inches of Teflon heat shrinkable tubing (Item 5) onto the prepared wire assembly and shrink using a heat gun. The chosen size of heat shrinkage tubing must accommodate both the number of conductors present in the cable as well as the Flat Braid (Item 6) to be attached.

Teflon Heat Shrinkable Tubing:

Reference the following MIL-Spec for general Teflon heat shrinkable tubing (M23053/5-X-Y)

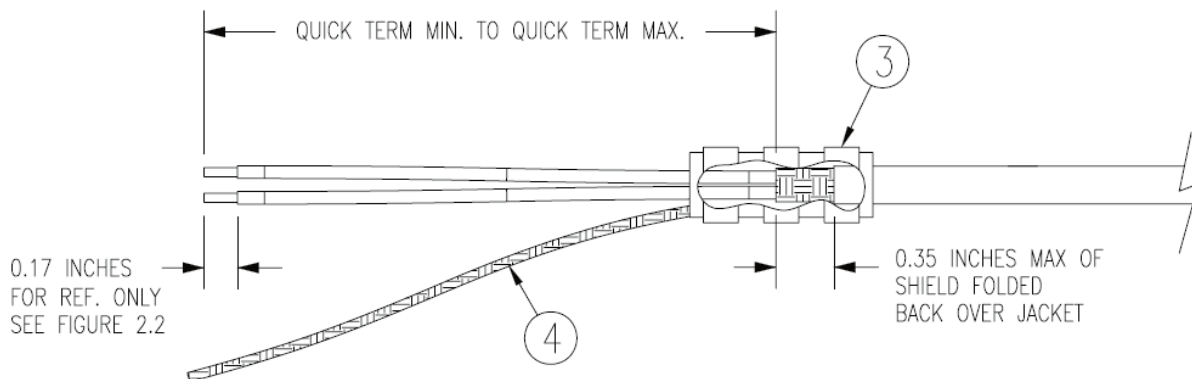

Figure B-5 Method B.1 (Quick Term) for Shield Termination

Table B-4 Shielded Cable Preparations – (Quick Term)

Backshell Size	Number of Pins Std/HD	Quick Term Min (inches)	Quick Term Max (inches)	Quick Term Float (inches)
1	9/15	1.25	2.25	1.75
2	15/26	1.5	2.5	2.0
3	25/44	1.5	2.5	2.0
4	37/62	1.5	2.5	2.0
5	50/78	1.5	2.5	2.0

B.5 Shield Termination-Method B.2 (Daisy Chain-Quick Term)

In rare situations where more braids need to be terminated for a connector than three per ring terminal it is allowable to daisy chain a maximum of two shields together before coming to the ring terminal (Figure B-6). All other restrictions and instructions for the shield termination technique set forth for Method A.1 are still applicable.



NOTE

The maximum length of the combined braids should be approximately 4 inches.

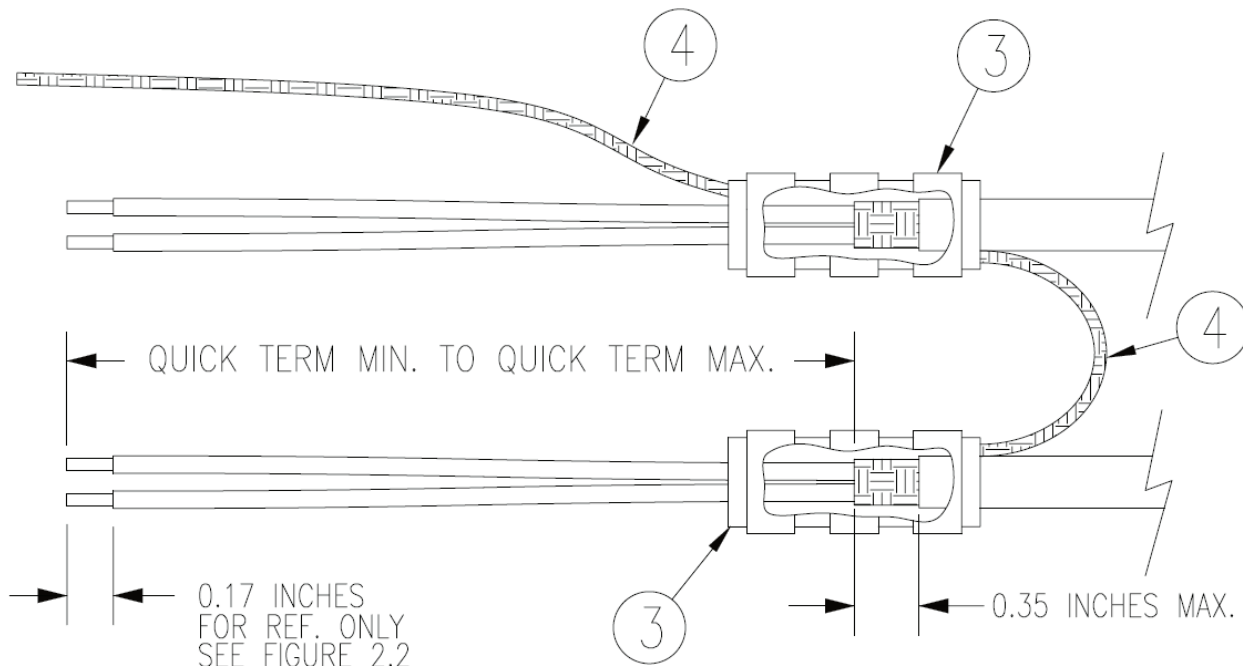

Figure B-6 Method B.2 (Daisy Chain-Quick Term) for Shield Termination

B.6 Daisy Chain between Methods A and B

In rare situations where more braids need to be terminated for a connector than three per ring terminal and a mixture of Methods A and B have been used, it is allowable to daisy chain a maximum of two shields together from a Method A termination to a Method B (Figure B-7). All other restrictions and instructions for the shield termination technique set forth for Method A and B are still applicable.



NOTE

The maximum length of the combined braids should be approximately 4 inches.

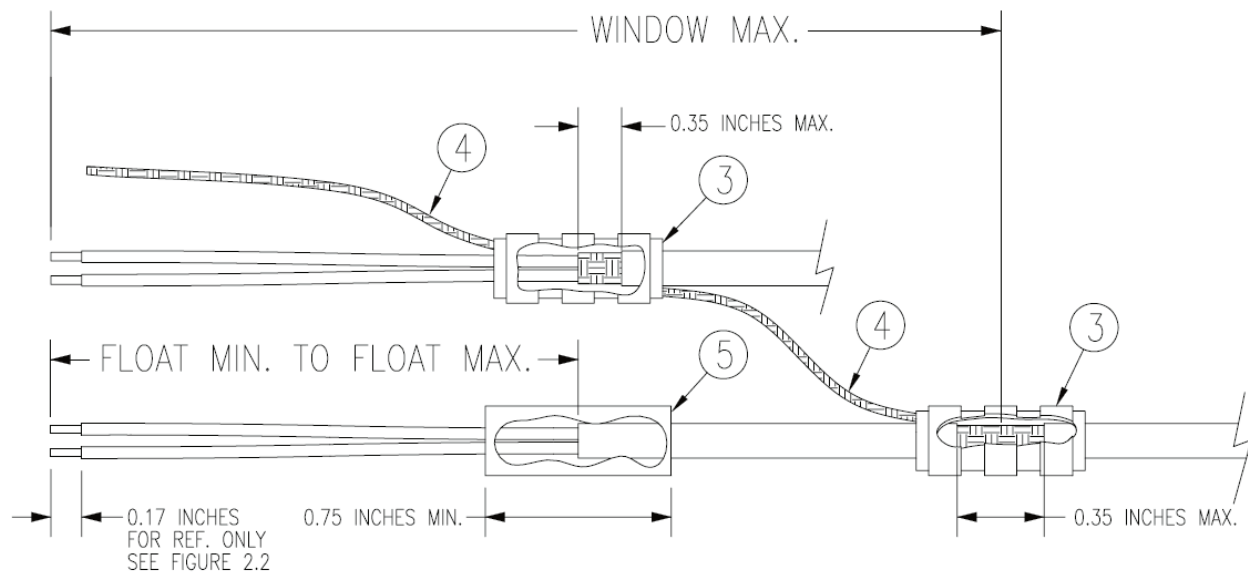

Figure B-7 Daisy Chain between Methods A and B

B.7 Splicing Signal Wires



NOTE

Figure B-8 illustrates that a splice must be made within a 3 inch window from outside the edge of clamp to the end of the 3 inch max mark.



WARNING

Keep the splice out of the backshell for pin extraction, and outside of the strain relief to avoid preloading.

Figure B-8 shows a two wire splice, but a maximum of three wires can be spliced. If a third wire is spliced, it is located out front of splice along with signal wire going to pin.

Splice part numbers:

- Raychem D-436-36/37/38
- MIL Spec MIL-S-81824/1

This technique may be used with shield termination methods: A.1, A.2, B.1, and B.2.

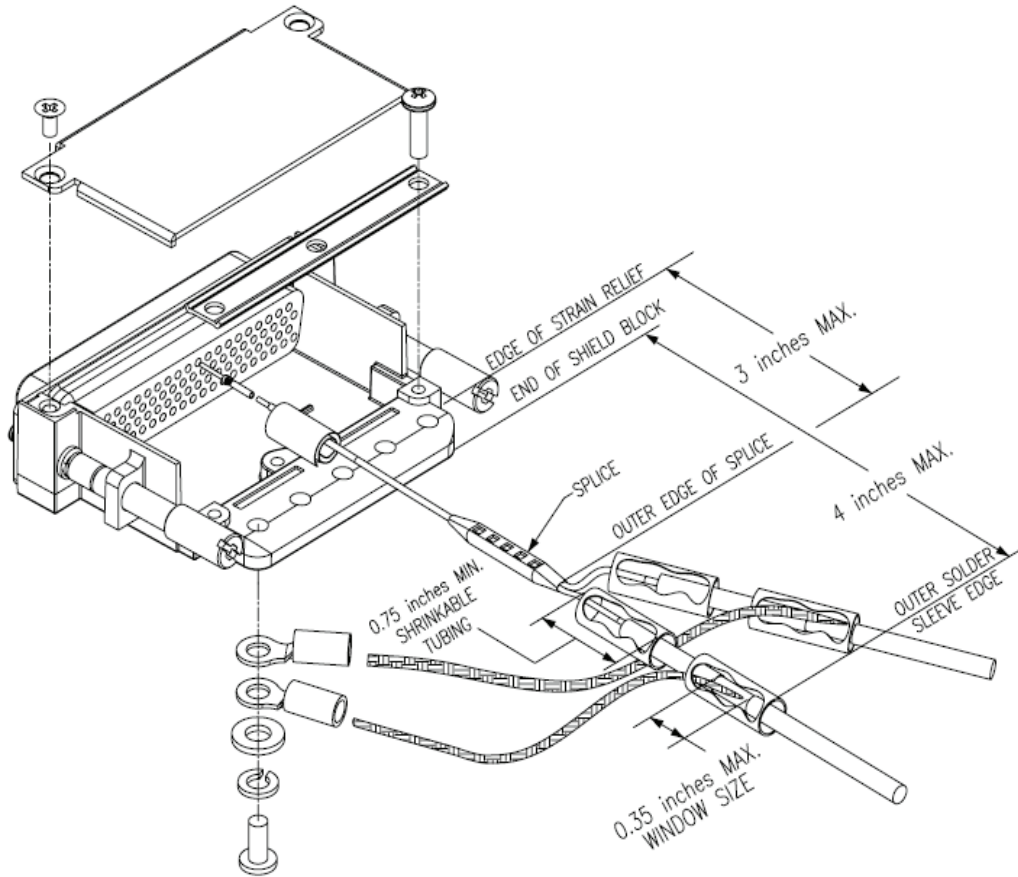
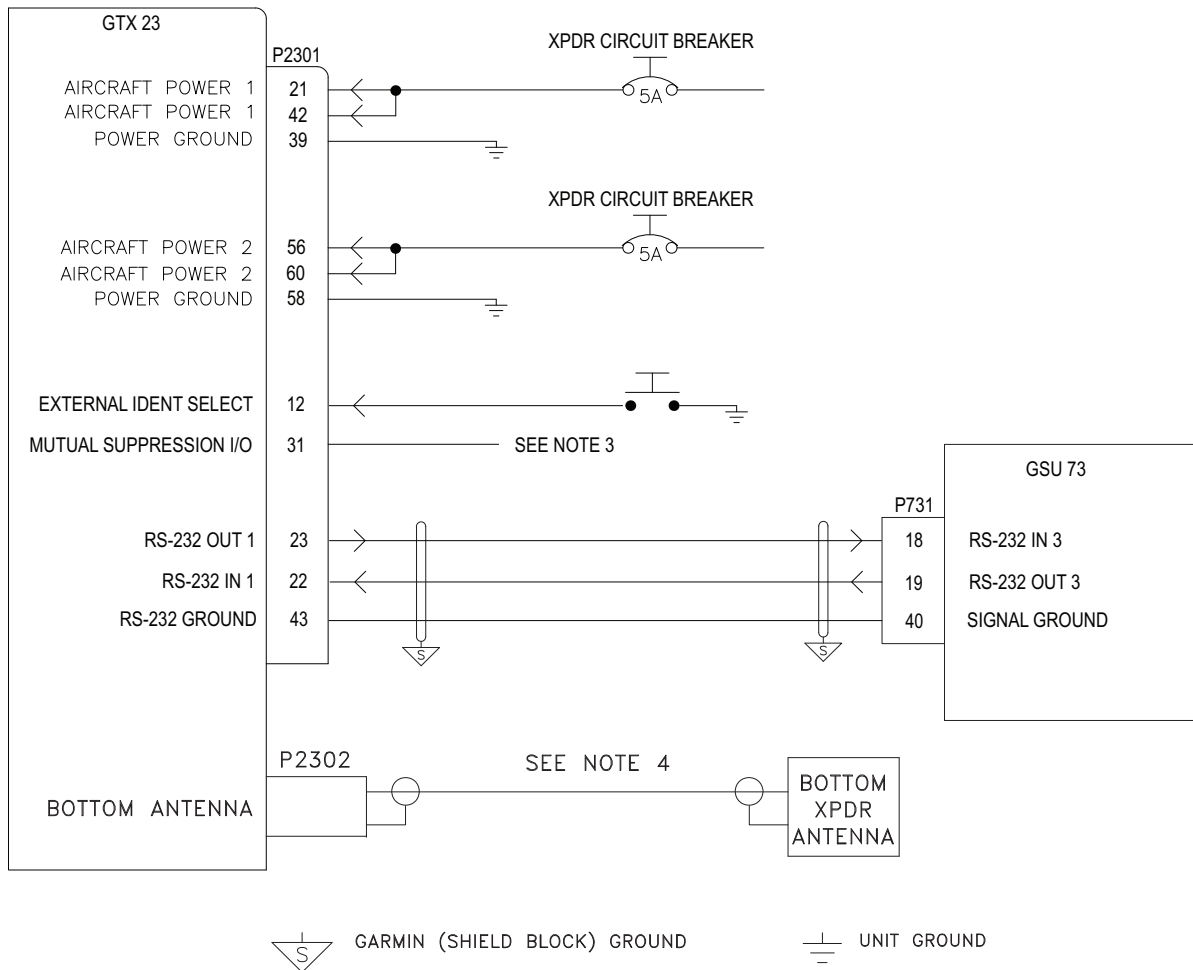

Figure B-8 D-Sub Spliced Signal Wire illustration

APPENDIX C INTERCONNECT DRAWINGS (Example Only)



NOTES:

1. USE 22 AWG WIRE FOR AIRCRAFT POWER AND AIRCRAFT GROUND. ALL OTHER WIRES 24 AWG OR LARGER UNLESS OTHERWISE NOTED.
2. FOR 14 Vdc INSTALLATIONS, THE USE OF TWO AIRCRAFT POWER AND TWO AIRCRAFT GROUND CONTACTS IN THE CONNECTOR IS RECOMMENDED FOR EACH POWER BUS CONNECTION. 28 Vdc INSTALLATIONS ONLY REQUIRE ONE AIRCRAFT POWER AND ONE AIRCRAFT GROUND CONTACT IN THE CONNECTOR FOR EACH POWER BUS CONNECTION.
3. EXTERNAL SUPPRESSION (P2301-31) SENDS AND ACCEPTS POSITIVE-GOING SUPPRESSION PULSES TO/FROM OTHER EQUIPMENT THAT TRANSMITS OR RECEIVES IN THE L-BAND. EXAMPLES OF THIS EQUIPMENT INCLUDE ANOTHER TRANSPONDER, A DME, AND A TCAS. SUPPRESSION PULSES MAY NOT BE COMPATIBLE WITH ALL MODELS OF EQUIPMENT. KNOWN INCOMPATIBILITIES INCLUDE THE BENDIX/KING KN 62, KN 64, AND KNS 80.
4. ROUTE THE ANTENNA CABLE AS FAR AS PRACTICAL FROM ANY HARNESS BUNDLE. IN NO CASE SHOULD THE ANTENNA CABLE BE PLACED INTO A HARNESS BUNDLE. MAXIMUM COAXIAL CABLE LOSS IS 1.5 DB AT 1090 MHZ.

Figure C-1 Core Interconnect Examples

APPENDIX C INTERCONNECT DRAWINGS (EXAMPLE ONLY)

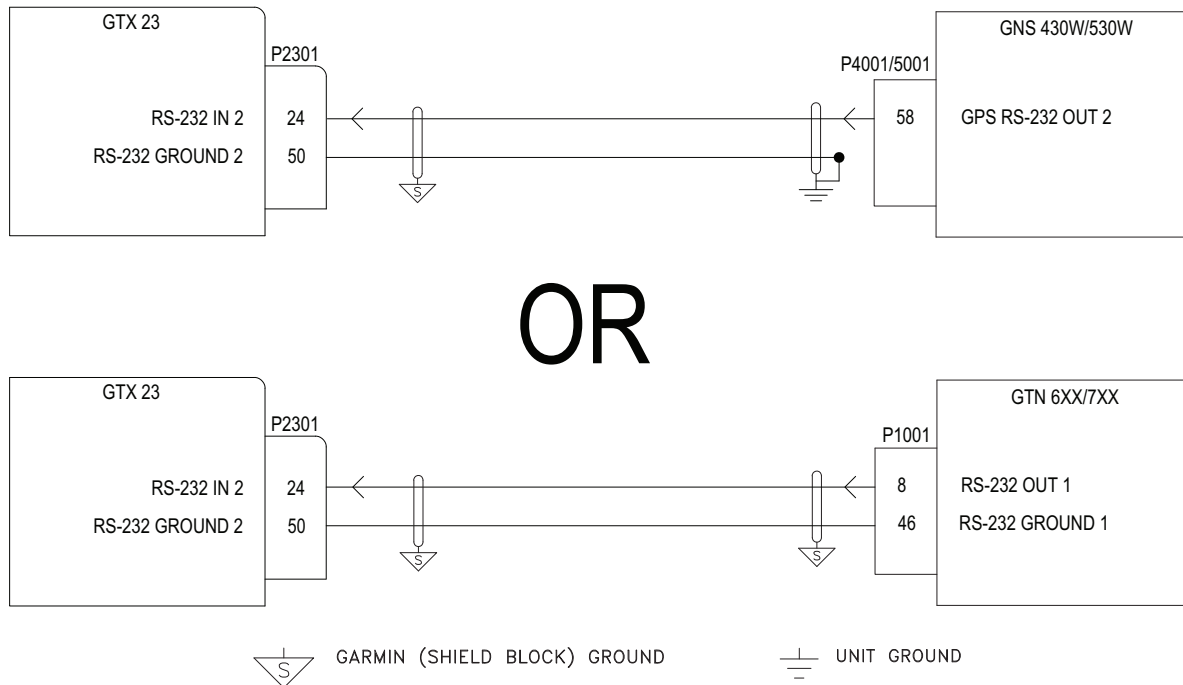

NOTES:

1. IF THE INSTALLATION DOES NOT INTEND TO TRANSMIT ADS-B INFORMATION, THEN NONE OF THE CONNECTIONS ON THIS PAGE ARE NECESSARY. IF THE INSTALLATION DOES INTEND TO TRANSMIT ADS-B INFORMATION, THEN EITHER A GNS 4XXW/5XXW-SERIES UNIT OR A GTN 6XX/7XX SERIES UNIT MUST BE USED TO SOURCE TSOA GPS DATA FOR ADS-B.
2. IF A GNS OR GTN IS USED TO SOURCE TSOA GPS DATA FOR ADS-B, THE GNS OR GTN MUST BE CONFIGURED FOR THIS SETUP. PLEASE SEE FOLLOWING CONFIGURATION GUIDANCE.
3. ALL WIRES 24 AWG OR LARGER UNLESS OTHERWISE NOTED.
4. THE GTX23 REQUIRES THAT RS-232 INPUT #2 BE USED FOR TSOA GPS DATA, BUT ANY UNUSED RS-232 OUTPUT ON THE GNS OR GTN MAY BE USED.

ADS-B Setup

In order to be ADS-B compliant, the GTX 23 must receive TSOA GPS data from a GTN 6XX/7XX or GNS 4XXW/5XXW-series unit. If a GNS is used, it must have main software 3.20 or later.

Directions for setting up a GTN to provide GPS data:

- Following directions in the GTN installation manual, go to the RS-232 configuration page. Configure the RS-232 output connected to the GTX to the “ADS-B” format. Configure the corresponding RS-232 input, which is not connected to the GTX23, to “Off.”

Directions for setting up a GNS 4XXW/5XXW-series unit to provide GPS data:

- Following directions in the GNS installation manual, go to the RS-232 configuration page. Configure the RS-232 output connected to the GTX to the “ADS-B OUT” format.

Figure C-2 ADS-B Interconnect Examples

APPENDIX C Interconnect Drawings (Example Only)

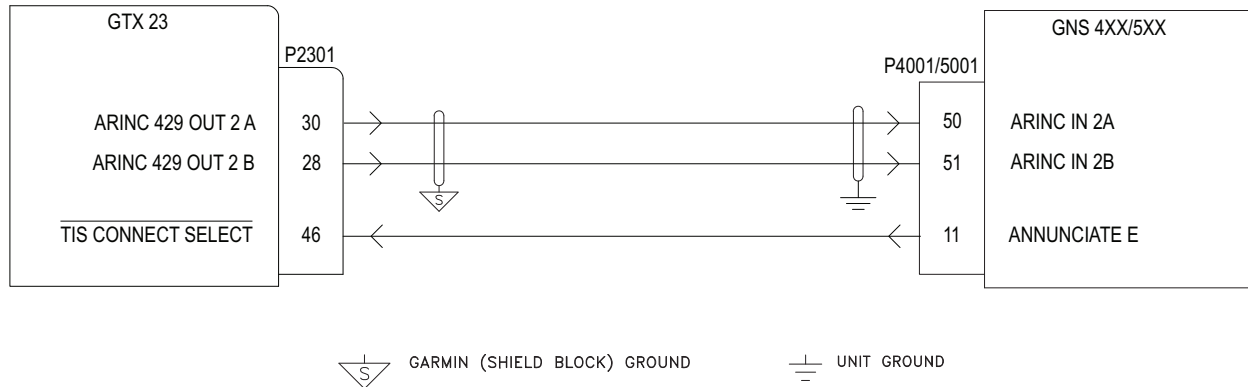

NOTES:

1. THE CONNECTIONS ON THIS PAGE ARE OPTIONAL. THE GDU 37X WILL DISPLAY TIS DATA. THESE CONNECTIONS ENABLE TIS TO BE DISPLAYED ON A GNS 4XXW/5XXW-SERIES UNIT.
2. IF TIS WILL BE DISPLAYED ON A GNS, THE GNS MUST BE CONFIGURED FOR THIS SETUP. PLEASE SEE THE FOLLOWING CONFIGURATION GUIDANCE.
3. ALL WIRES 24 AWG OR LARGER UNLESS OTHERWISE NOTED.
4. THE GTX 23 REQUIRES THAT ARINC 429 OUTPUT #2 BE USED FOR TIS, BUT ANY UNUSED ARINC 429 INPUT ON THE GNS MAY BE USED.
5. WHEN TIS IS USED ON A GNS, DO NOT CONNECT ANOTHER TRAFFIC SYSTEM TO THE SAME GNS SERIES UNIT.
6. THE SINGLE WIRE CONNECTED TO THE TIS CONNECT SELECT INPUT OF THE GTX 23 IS OPTIONAL. THE GNS CAN COMMAND THE GTX TO PUT TIS IN STANDBY MODE. THIS WIRE IS NECESSARY TO PUT TIS INTO AND BRING IT OUT OF STANDBY MODE.

TIS Setup

The GDU 37X will display TIS traffic data from the GTX 23, but one also has the option of displaying TIS traffic data on a GNS 4XXW/5XXW-series unit.

Directions for setting up a GNS 4XXW/5XXW-series unit to display TIS data:

- Following directions in the GNS installation manual, go to the ARINC 429 configuration page. Configure the ARINC input connected to the GTX to:
 - o Speed=High
 - o Format=Garmin GTX 330

Figure C-3 TIS Display Options Example

APPENDIX D OUTLINE AND INSTALLATION DRAWINGS

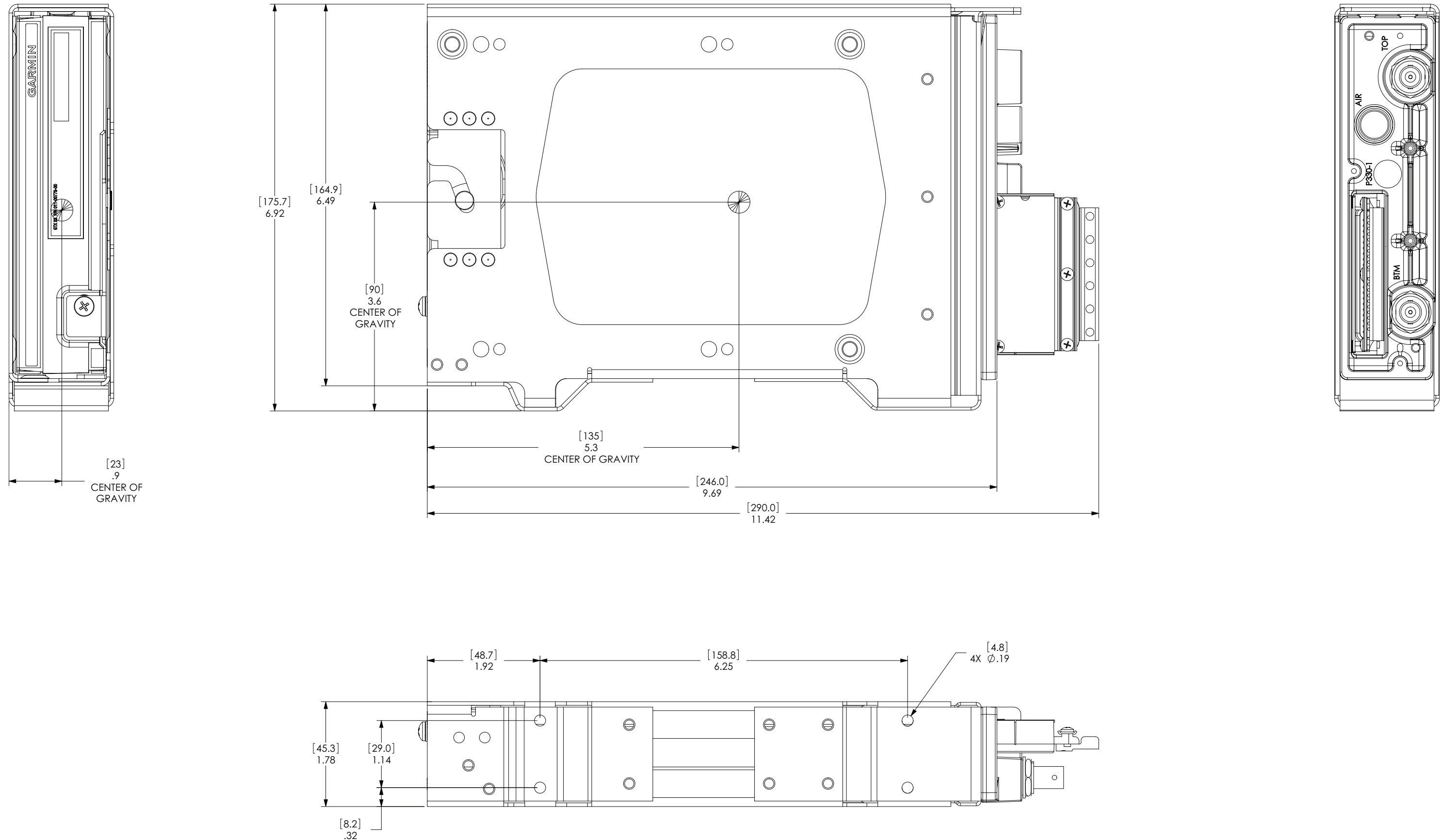

Figure D-1 GTX 23 in Standalone Rack, Outline Drawing

APPENDIX D OUTLINE AND INSTALLATION DRAWINGS

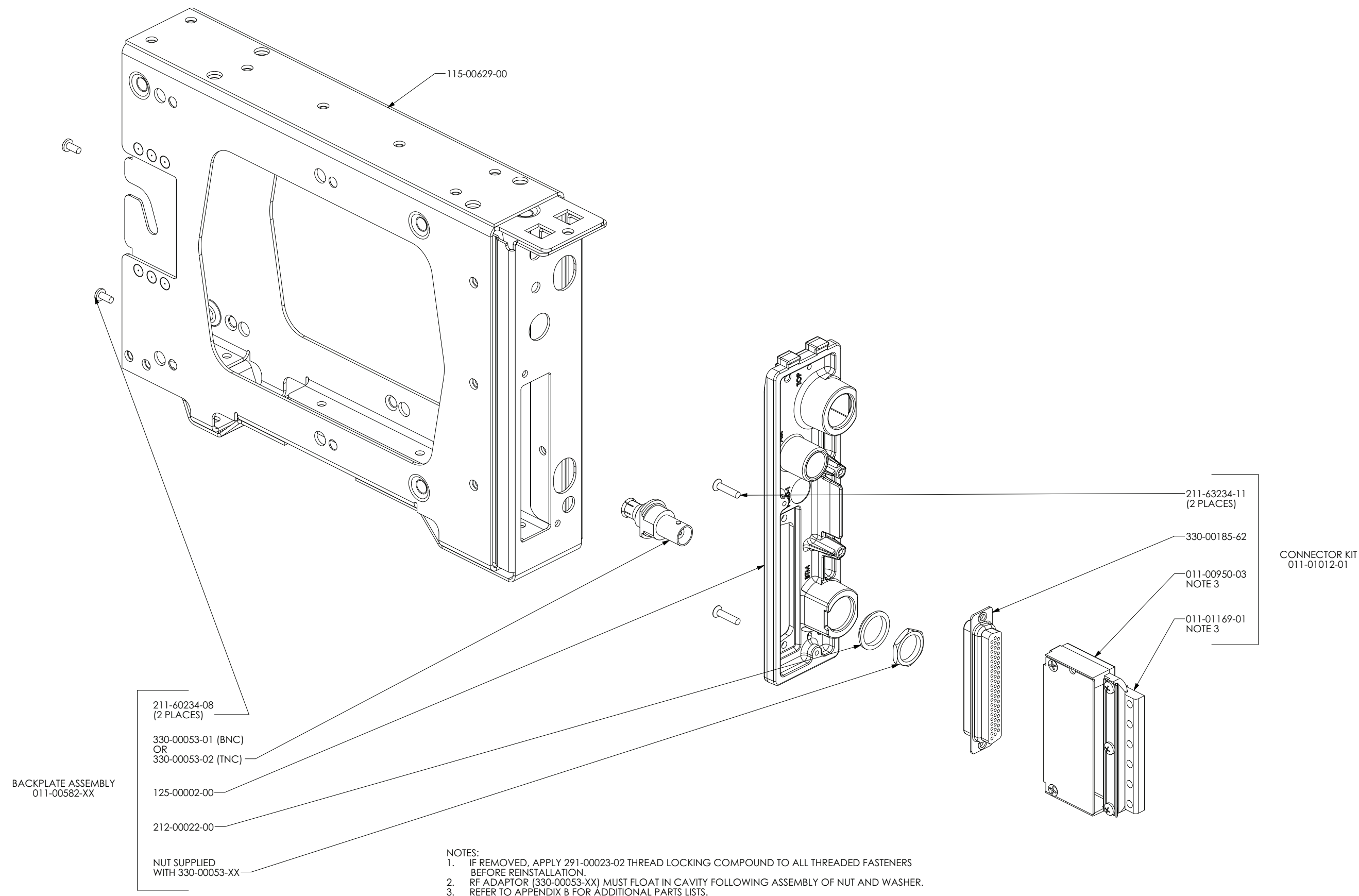

Figure D-2 GTX 23 Connector/Standalone Rack Assembly Drawing

APPENDIX D OUTLINE AND INSTALLATION DRAWINGS

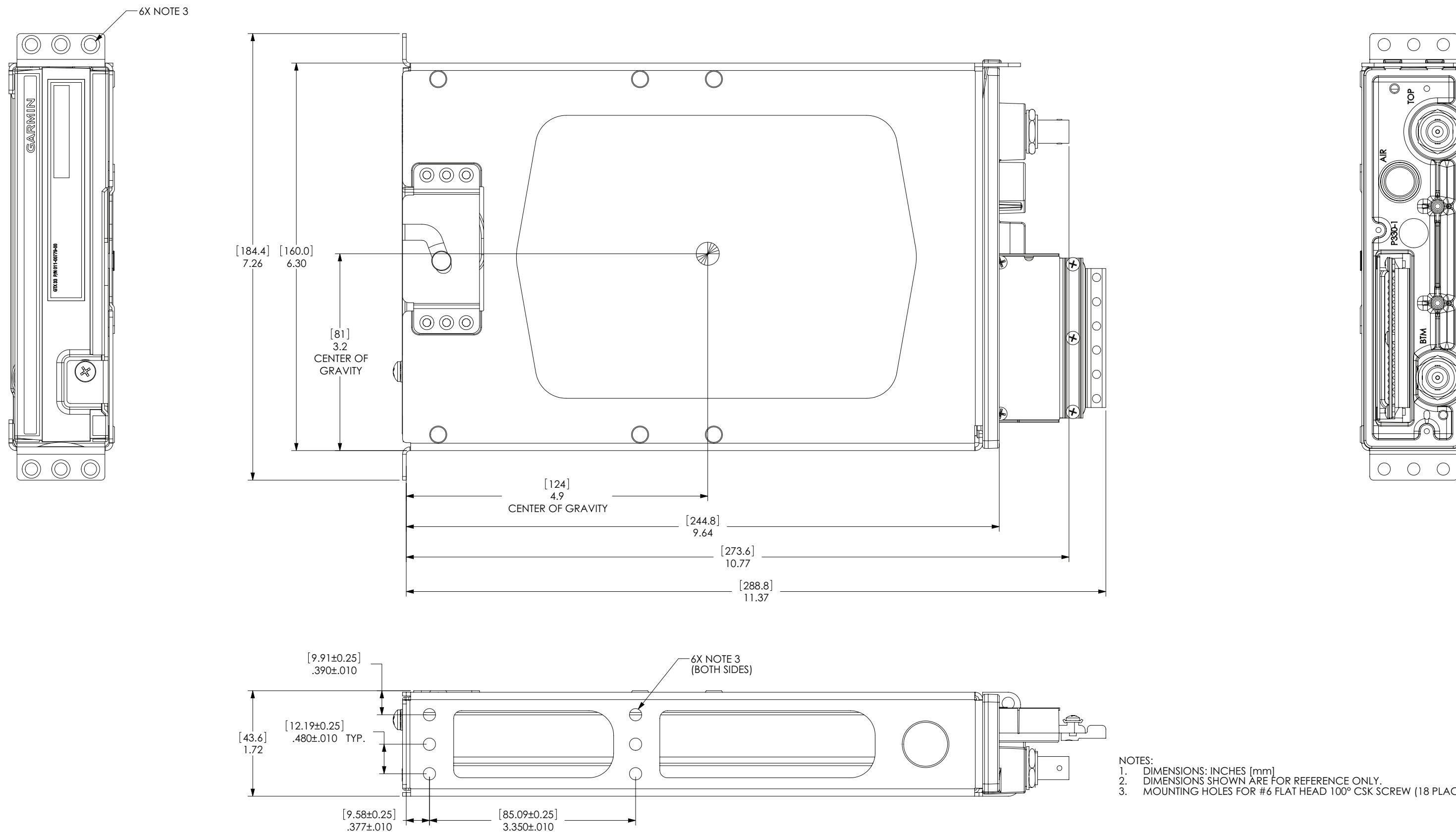

Figure D-3 GTX 23 in Modular Rack, Outline Drawing

APPENDIX D OUTLINE AND INSTALLATION DRAWINGS

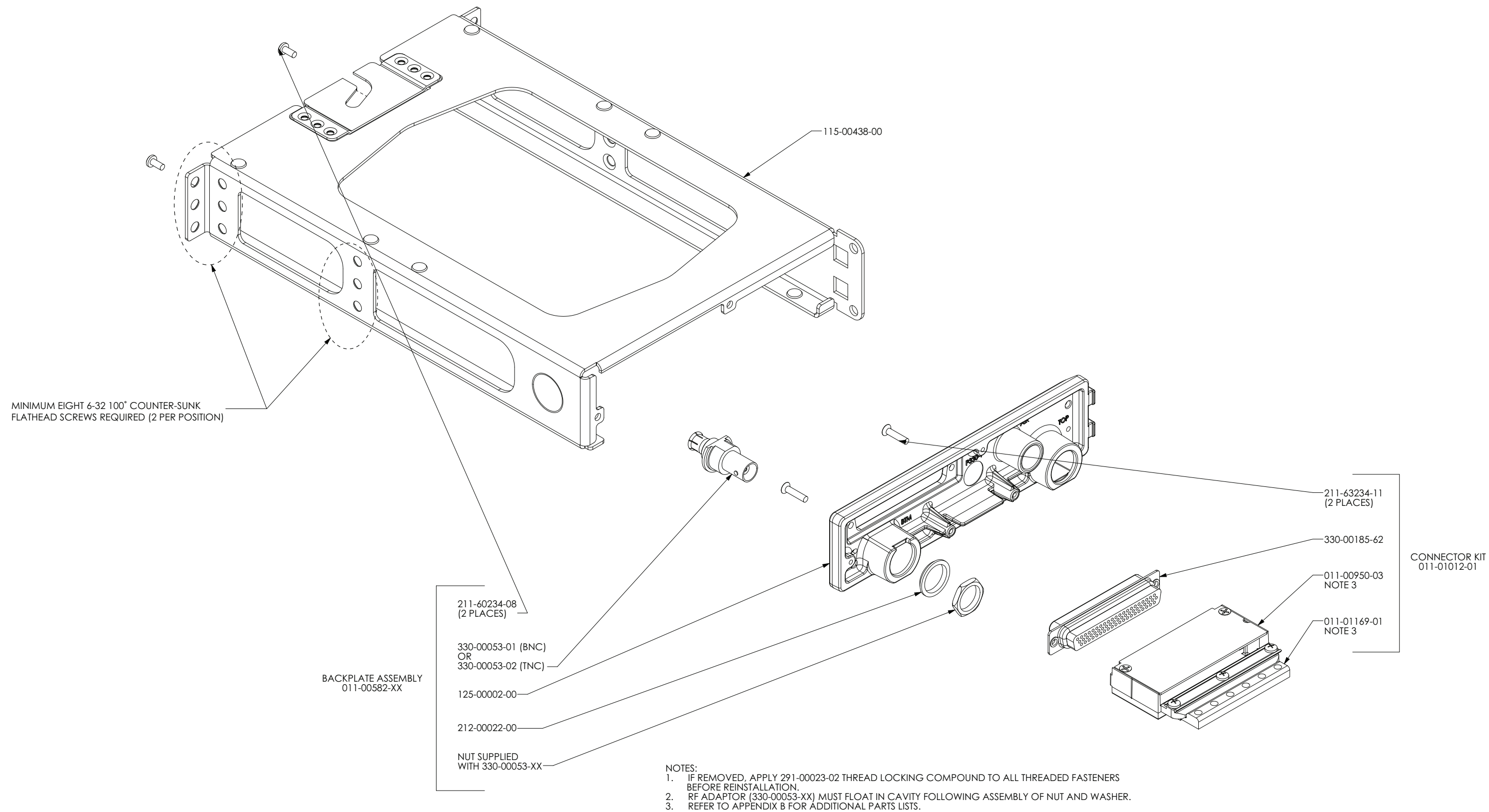

Figure D-4 GTX 23 Connector/Modular Rack Assembly Drawing

Free Manuals Download Website

<http://myh66.com>

<http://usermanuals.us>

<http://www.somanuals.com>

<http://www.4manuals.cc>

<http://www.manual-lib.com>

<http://www.404manual.com>

<http://www.luxmanual.com>

<http://aubethermostatmanual.com>

Golf course search by state

<http://golfingnear.com>

Email search by domain

<http://emailbydomain.com>

Auto manuals search

<http://auto.somanuals.com>

TV manuals search

<http://tv.somanuals.com>