

G1000[®] **Integrated Flight Deck** **Cockpit Reference Guide**



Columbia
350/400

Copyright © 2006 Garmin Ltd. or its subsidiaries. All rights reserved.

This manual reflects the operation of System Software version 0530.01 or later for the Columbia 400 and System Software version 0545.00 or later for the Columbia 350. Some differences in operation may be observed when comparing the information in this manual to earlier or later software versions.

Garmin International, Inc., 1200 East 151st Street, Olathe, Kansas 66062, U.S.A.
Tel: 913/397.8200 Fax: 913/397.8282

Garmin AT, Inc., 2345 Turner Road SE, Salem, OR 97302, U.S.A.
Tel: 503/391.3411 Fax 503/364.2138

Garmin (Europe) Ltd., Unit 5, The Quadrangle, Abbey Park Industrial Estate, Romsey, Hampshire S051 9DL, U.K.
Tel: 44/0870.8501241 Fax: 44/0870.8501251

Garmin Corporation, No. 68, Jangshu 2nd Road, Shijr, Taipei County, Taiwan
Tel: 886/02.2642.9199 Fax: 886/02.2642.9099

Web Site Address: www.garmin.com

Except as expressly provided herein, no part of this manual may be reproduced, copied, transmitted, disseminated, downloaded or stored in any storage medium, for any purpose without the express written permission of Garmin. Garmin hereby grants permission to download a single copy of this manual and of any revision to this manual onto a hard drive or other electronic storage medium to be viewed for personal use, provided that such electronic or printed copy of this manual or revision must contain the complete text of this copyright notice and provided further that any unauthorized commercial distribution of this manual or any revision hereto is strictly prohibited.

Garmin® and G1000® are registered trademarks of Garmin Ltd. or its subsidiaries. These trademarks may not be used without the express permission of Garmin.

NavData® is a registered trademark of Jeppesen, Inc.; Stormscope® is a registered trademarks of L-3 Communications; and XM® is a registered trademark of XM Satellite Radio, Inc.; Ryan® is a registered trademark of Avidyne Corporation.



WARNING: Navigation and terrain separation must NOT be predicated upon the use of the terrain function. The G1000 Terrain Proximity feature is NOT intended to be used as a primary reference for terrain avoidance and does not relieve the pilot from the responsibility of being aware of surroundings during flight. The Terrain Proximity feature is only to be used as an aid for terrain avoidance and is not certified for use in applications requiring a certified terrain awareness system. Terrain data is obtained from third party sources. Garmin is not able to independently verify the accuracy of the terrain data.



WARNING: The displayed minimum safe altitudes (MSAs) are only advisory in nature and should not be relied upon as the sole source of obstacle and terrain avoidance information. Always refer to current aeronautical charts for appropriate minimum clearance altitudes.



WARNING: The altitude calculated by G1000 GPS receivers is geometric height above Mean Sea Level and could vary significantly from the altitude displayed by pressure altimeters, such as the GDC 74A Air Data Computer, or other altimeters in aircraft. GPS altitude should never be used for vertical navigation. Always use pressure altitude displayed by the G1000 PFD or other pressure altimeters in aircraft.



WARNING: The Jeppesen database used in the G1000 system must be updated regularly in order to ensure that its information remains current. Updates are released every 28 days. A database information packet is included in the G1000 package. Pilots using an outdated database do so entirely at their own risk.



WARNING: The basemap (land and water data) must not be used for navigation, but rather only for non-navigational situational awareness. Any basemap indication should be compared with other navigation sources.



WARNING: Traffic information shown on the G1000 Multi Function Display is provided as an aid in visually acquiring traffic. Pilots must maneuver the aircraft based only upon ATC guidance or positive visual acquisition of conflicting traffic.



WARNING: Use of the Stormscope is not intended for hazardous weather penetration (thunderstorm penetration). Stormscope information, as displayed on the G1000 MFD, is to be used only for weather avoidance, not penetration.



WARNING: GDL 69 Weather should not be used for hazardous weather penetration. Weather information provided by the GDL 69 is approved only for weather avoidance, not penetration.



WARNING: NEXRAD weather data is to be used for long-range planning purposes only. Due to inherent delays in data transmission and the relative age of the data, NEXRAD weather data should not be used for short-range weather avoidance.



WARNING: The Garmin G1000, as installed in the Columbia 350/400 aircraft, has a very high degree of functional integrity. However, the pilot must recognize that providing monitoring and/or self-test capability for all conceivable system failures is not practical. Although unlikely, it may be possible for erroneous operation to occur without a fault indication shown by the G1000. It is thus the responsibility of the pilot to detect such an occurrence by means of cross-checking with all redundant or correlated information available in the cockpit.



WARNING: For safety reasons, G1000 operational procedures must be learned on the ground.



WARNING: The United States government operates the Global Positioning System and is solely responsible for its accuracy and maintenance. The GPS system is subject to changes which could affect the accuracy and performance of all GPS equipment. Portions of the Garmin G1000 utilize GPS as a precision electronic NAVigation AID (NAVAID). Therefore, as with all NAVAIDs, information presented by the G1000 can be misused or misinterpreted and, therefore, become unsafe.



WARNING: To reduce the risk of unsafe operation, carefully review and understand all aspects of the G1000 Pilot's Guide documentation and the Columbia 350/400 Pilot's Operating Handbook. Thoroughly practice basic operation prior to actual use. During flight operations, carefully compare indications from the G1000 to all available navigation sources, including the information from other NAVAIDs, visual sightings, charts, etc. For safety purposes, always resolve any discrepancies before continuing navigation.



WARNING: The illustrations in this guide are only examples. Never use the G1000 to attempt to penetrate a thunderstorm. Both the FAA Advisory Circular, Subject: Thunderstorms, and the Airman's Information Manual (AIM) recommend avoiding "by at least 20 miles any thunderstorm identified as severe or giving an intense radar echo."



CAUTION: The GDU 1040 PFD and GDU 1042 MFD displays use a lens coated with a special anti-reflective coating that is very sensitive to skin oils, waxes, and abrasive cleaners. **CLEANERS CONTAINING AMMONIA WILL HARM THE ANTI-REFLECTIVE COATING.** It is very important to clean the lens using a clean, lint-free cloth and an eyeglass lens cleaner that is specified as safe for anti-reflective coatings.



CAUTION: The Garmin G1000 does not contain any user-serviceable parts. Repairs should only be made by an authorized Garmin service center. Unauthorized repairs or modifications could void both the warranty and the pilot's authority to operate this device under FAA/FCC regulations.



NOTE: When using Stormscope, there are several atmospheric phenomena in addition to nearby thunderstorms that can cause isolated discharge points in the strike display mode. However, clusters of two or more discharge points in the strike display mode do indicate thunderstorm activity if these points reappear after the screen has been cleared.



NOTE: All visual depictions contained within this document, including screen images of the G1000 panel and displays, are subject to change and may not reflect the most current G1000 system. Depictions of equipment may differ slightly from the actual equipment.



NOTE: This device complies with part 15 of the FCC Rules. Operation is subject to the following two conditions: (1) this device may not cause harmful interference, and (2) this device must accept any interference received, including interference that may cause undesired operation.



NOTE: This product, its packaging, and its components contain chemicals known to the State of California to cause cancer, birth defects, or reproductive harm. This notice is being provided in accordance with California's Proposition 65. If you have any questions or would like additional information, please refer to our web site at www.garmin.com/prop65.

Part Number	Change Summary
190-00567-00	Production release.

Revision	Date of Revision	Affected Pages	Description
A	3/06	i-Index-4	Production release
B	6/06	i-Index-4	Added Columbia 350 parameters, TAWS changes, and Stormscope.

Blank Page

SECTION 1: SYSTEM OVERVIEW	1-1	Engine Leaning for the Columbia 400.....	3-5
1.1 PFD/MFD Controls	1-2	<i>Leaning for Best Power</i>	3-5
1.2 GCU 476 Controls	1-4	<i>Leaning for Best Economy</i>	3-5
1.3 PFD Softkeys	1-6	3.3 Fuel Calculations	3-6
1.4 MFD Softkeys	1-9	SECTION 4: NAV/COM AND TRANSPONDER	4-1
1.5 MFD Page Groups	1-10	4.1 Radio Status Indications	4-3
1.6 Backlighting	1-10	4.2 Volume	4-3
1.7 Database Updates	1-11	4.3 Automatic Squelch	4-3
Aviation Database Update.....	1-11	4.4 Quickly Activating 121.500 MHz	4-3
Terrain and Obstacle Database Updates.....	1-11	4.5 Frequency Auto-tuning	4-3
SECTION 2: FLIGHT INSTRUMENTS	2-1	Auto-tuning on the PFD.....	4-3
2.1 Airspeed Indicator	2-3	Auto-tuning on the MFD.....	4-3
Speed Indication.....	2-3	4.6 Transponder	4-4
Speed Ranges.....	2-3	Mode Selection.....	4-4
Airspeed Trend Vector.....	2-3	<i>Ground Mode (Automatic)</i>	4-4
Vspeed References.....	2-3	<i>Reply Status</i>	4-4
2.2 Attitude Indicator	2-3	<i>Code Selection</i>	4-4
2.3 Altimeter	2-4	SECTION 5: AUDIO PANEL	5-1
Altitude Select Bug.....	2-4	5.1 COM Radio Selection	5-2
Altitude Trend Vector.....	2-4	5.2 Split COM Function	5-2
Barometric Setting Box.....	2-4	5.3 Marker Beacon Receiver	5-2
Altitude Alerting.....	2-4	5.4 Nav Radio Audio Selection	5-3
Barometric Minimum Descent Altitude.....	2-4	5.5 Intercom System (ICS) Isolation	5-3
2.4 Vertical Deviation/Glideslope Indicator	2-5	5.6 Intercom Squelch Control	5-4
2.5 Marker Beacon Annunciations	2-5	5.7 Digital Clearance Recorder and Player	5-4
2.6 Vertical Speed Indicator	2-5	SECTION 6: AUTOMATIC FLIGHT CONTROL	6-1
2.7 Horizontal Situation Indicator (HSI)	2-6	6.1 Mode Annunciations	6-1
Arc HSI.....	2-6	6.2 Overspeed Protection	6-2
Turn Rate Indicator and Heading Trend Vector.....	2-6	6.3 AP Engagement/Disengagement	6-2
Course Pointer.....	2-7	Automatic Disengagement.....	6-3
Course Deviation Indicator (CDI).....	2-7	Manual Disengagement.....	6-3
Bearing Pointers and Information Windows.....	2-7	Control Wheel Steering.....	6-3
Navigation Source.....	2-8	6.4 Loss of Data	6-3
SECTION 3: ENGINE INDICATION SYSTEM (EIS)	3-1	6.5 Pitch Axis Modes	6-3
3.1 EIS Display	3-2	Pitch Hold Mode (PIT).....	6-4
Oxygen System (Optional).....	3-2	Altitude Hold Mode (ALT).....	6-5
Trim.....	3-2	Vertical Speed Mode (VS).....	6-6
Carbon Monoxide Detection.....	3-2	Flight Level Change Mode (FLC).....	6-7
3.2 Engine Leaning Assist Display	3-3	Go-Around Mode (GA).....	6-8
Engine Leaning for the Columbia 350.....	3-3	Glideslope (GS).....	6-8
<i>Leaning for Best Power</i>	3-3		
<i>Leaning for Best Economy</i>	3-4		

TABLE OF CONTENTS

6.6 Roll Axis Modes	6-9	7.8 Nearest Airports	7-5
Roll Hold Mode (ROL).....	6-9	Nearest Airport Information on the MFD.....	7-5
Heading Select Mode (HDG).....	6-10	<i>Select the Nearest Airports Page</i>	7-5
Navigation Mode (GPS, VOR, LOC, or BC).....	6-11	<i>Access Information on a Specific Airport</i>	7-6
<i>Navigation Mode Armed</i>	6-11	<i>Access Runway Information for the Selected</i>	
Approach Mode (GPS, VAPP or LOC).....	6-12	<i>Airport</i>	7-6
Go Around (GA).....	6-12	<i>Quickly Tune the COM Transceiver to a Nearby</i>	
6.7 Example Procedures Using AFCS	6-13	<i>Airport Frequency</i>	7-6
Departure.....	6-14	Nearest Airports Information on the PFD.....	7-6
Intercepting a VOR Radial.....	6-15	<i>View Information on a Specific Airport in the List</i>	7-6
Flying a GPS Flight Plan.....	6-16	<i>Load an Airport COM Frequency into the</i>	
Flight Level Change (Descent).....	6-17	<i>Active COM</i>	7-6
ILS Approach.....	6-18	7.9 Nearest Intersections	7-7
Go-Around / Missed Approach.....	6-19	Select the Nearest Intersections Page.....	7-7
		<i>View Information on the Nearest Intersection</i>	7-7
SECTION 7: NAVIGATION	7-1	7.10 Nearest NDB	7-7
7.1 Navigation Map Page	7-1	Select the Nearest NDB Page.....	7-7
Select the MAP Page Group.....	7-1	<i>Access Information on a Specific NDB</i>	7-7
7.2 Direct-to Navigation	7-1	7.11 Nearest VOR	7-8
Direct-to Navigation from the MFD.....	7-1	Select the Nearest VOR Page.....	7-8
<i>Enter a Direct-to Destination</i>	7-1	<i>View Information on the Nearest VOR</i>	7-8
<i>Select a Direct-to Destination to a Flight Plan</i>		<i>Select and Load a VOR Frequency</i>	7-8
<i>Waypoint or Nearest Airport</i>	7-1	7.12 Nearest User Waypoint	7-8
<i>Re-center the CDI to the Destination Waypoint</i>	7-2	Select the Nearest User Waypoint Page.....	7-8
<i>Manually Define the Direct-to Course</i>	7-2	<i>Select a Nearest User Waypoint</i>	7-8
<i>Canceling Direct-to Navigation</i>	7-2	7.13 Nearest Frequencies	7-9
Direct-to Navigation from the PFD.....	7-2	Select the Nearest Frequencies Page.....	7-9
<i>Cancelling Direct-to Navigation</i>	7-2	<i>Select and Load the Nearest ARTCC, FSS, or</i>	
7.3 Airport Information	7-3	<i>Weather Frequency</i>	7-9
Select the Airport Information Page.....	7-3	7.14 Nearest Airspaces	7-9
<i>Enter a Waypoint Facility Name or City Location</i>	7-3	Select the Nearest Airspaces Page.....	7-9
<i>Access Runway Information</i>	7-3	<i>Airspace Alerts Box</i>	7-9
<i>Access Frequency Information</i>	7-3	<i>View Additional Details for a Listed Airspace</i>	7-10
7.4 Intersection Information	7-4	<i>View and Quickly Load the Frequency for a</i>	
Select the Intersection Information Page.....	7-4	<i>Controlling Agency</i>	7-10
<i>Access Information on an Intersection</i>	7-4	SECTION 8: FLIGHT PLANNING	8-1
7.5 NDB Information	7-4	8.1 User Defined Waypoints	8-1
Select the NDB Information Page.....	7-4	Select the User WPT Information Page.....	8-1
<i>View Information on a Specific NDB</i>	7-4	<i>Create a New User Waypoint</i>	8-1
7.6 VOR Information	7-5	<i>Modify a User Waypoint</i>	8-1
Select the VOR Information Page.....	7-5	<i>Delete a User Waypoint</i>	8-1
<i>Access Information on a VOR</i>	7-5	Create User Waypoints from the Navigation	
7.7 User Waypoint Information Page	7-5	Map Page.....	8-2

8.2 Viewing the Active Flight Plan	8-2	Displaying Weather on the Weather Data Link Page ...	10-4
8.3 Activate a Stored Flight Plan	8-2	<i>NEXRAD Limitations</i>	10-4
8.4 Activate a Flight Plan Leg	8-3	Map Panning Information – Weather Data Link Page ..	10-5
8.5 Stop Navigating a Flight Plan	8-3	Weather Products and Symbols	10-5
8.6 Invert Active Flight Plan	8-3	Weather Product Age	10-6
8.7 Create a New Flight Plan	8-4	10.4 Traffic Information Service (TIS)	10-7
Create a New Flight Plan Using the MFD	8-4	Displaying Traffic on the Traffic Map Page	10-7
Create a New Flight Plan Using the PFD	8-4	Displaying Traffic on the Navigation Map	10-7
8.8 Load a Departure	8-5	TIS Audio Alert	10-7
8.9 Load an Arrival	8-5	10.5 Ryan® 9900BX Traffic Advisory System (TAS)	
8.10 Load an Approach	8-5	(Optional)	10-8
8.11 Remove a Departure, Arrival, or Approach		Displaying Traffic on the Traffic Map Page	10-8
from a Flight Plan	8-5	Displaying Traffic on the Navigation Map	10-8
8.12 Store a Newly Created Flight Plan	8-5	10.6 Terrain And Obstacle Proximity	10-9
8.13 Edit a Stored Flight Plan	8-5	Displaying Terrain and Obstacles on the Terrain	
8.14 Delete a Waypoint from the Flight Plan	8-5	Proximity Page	10-9
8.15 Invert and activate a Stored Flight Plan	8-6	Displaying Terrain and Obstacles on the	
8.16 Copy a Flight Plan	8-6	Navigation Map	10-9
8.17 Delete a Flight Plan	8-6	10.7 Terrain Awareness & Warning System	
8.18 Graphical Flight Plan Creation	8-6	(TAWS) Display (Optional)	10-10
8.19 Trip Planning	8-6	Displaying Terrain on the TAWS Page	10-10
8.20 Vertical Navigation (VNAV) Page	8-8	Enable/Disable Aviation Data	10-11
Create a Vertical Navigation Profile	8-8	TAWS Inhibit	10-12
VNAV Page Menu Options	8-9	Manual System Test	10-12
SECTION 9: PROCEDURES	9-1	Forward Looking Terrain Avoidance (FLTA)	10-12
9.1 Arrivals and Departures	9-1	<i>Reduced Required Terrain Clearance (RTC) and</i>	
Load and Activate a Departure Procedure	9-1	<i>Reduced Required Obstacle Clearance (ROC)</i>	10-12
Load and Activate An Arrival Procedure	9-1	<i>Imminent Terrain Impact (ITI) and Imminent</i>	
9.2 Approaches	9-2	<i>Obstacle Impact (IOI)</i>	10-12
Load and/or Activate an Approach Procedure	9-2	Premature Descent Alert (PDA)	10-12
Activate An Approach in the Active Flight Plan	9-3	Excessive Descent Rate Alert (EDR)	10-13
SECTION 10: HAZARD AVOIDANCE	10-1	Negative Climb Rate After Takeoff Alert (NCR)	10-13
10.1 Customizing the Hazard Displays on the		"Five-Hundred" Aural Alert	10-13
Navigation Map	10-1	Displaying Terrain and Obstacles on the	
10.2 STORMSCOPE® (Optional, 350 only)	10-1	Navigation Map	10-14
Displaying Stormscope Lightning Data on the		Pop-up Alerts	10-14
Navigation Map Page	10-1	TAWS Alerts Summary	10-15
Stormscope Page	10-2	Alert Annunciations	10-16
10.3 XM® Weather (Optional)	10-3	SECTION 11: ABNORMAL OPERATION	11-1
Displaying METAR and TAF information on the		11.1 Reversionary Mode	11-1
Airport Information Page	10-3	11.2 Abnormal COM Operation	11-2
		11.3 Unusual Attitudes	11-2

11.4 Stormscope operation with loss of Heading Input	11-2
11.5 Hazard Displays with Loss of GPS Position	11-2

SECTION 12: ANNUNCIATIONS & ALERTS..... 12-1

12.1 Alert Level Definitions	12-2
12.2 Aircraft Alerts	12-3
WARNING Alerts	12-3
CAUTION Alerts	12-3
Annunciation Advisory.....	12-4
Message Advisory Alerts	12-4
12.3 CO Guardian Messages	12-4
12.4 AFCS Alerts	12-5
System Status Annunciation.....	12-5
12.5 TAWS ALERTS	12-6
TAWS System Status Annunciations	12-7
12.6 G1000 System Annunciations	12-7
12.7 G1000 System Message Advisories	12-9
MFD & PFD Message Advisories.....	12-10
Database Message Advisories.....	12-11
GMA 1347 Message Advisories	12-12
GIA 63 Message Advisories	12-12
GEA 71 Message Advisories	12-14
GTX 33 Message Advisories.....	12-15
GRS 77 Message Advisories.....	12-15
GMU 44 Message Advisories	12-16
GDL 69 Message Advisories.....	12-16
GDC 74A Message Advisories.....	12-16
GCU 476 Message Advisories	12-16
Miscellaneous Message Advisories.....	12-17

INDEX	Index-1
--------------------	---------

SECTION 1: SYSTEM OVERVIEW

The purpose of this Cockpit Reference Guide is to provide the pilot a resource with which to find operating instructions on the major features of the G1000 system more easily. **It is not intended to be a comprehensive operating guide.** Complete operating procedures for the complete system are found in the G1000 Columbia 350/400 Pilot's Guide (190-00552-00):

This guide gives the pilot abbreviated operating instructions for the Primary Flight Display (PFD), Multi Function Display (MFD), GCU 476 MFD/PFD Control Unit, and the GMA 1347 Audio Panel System.



NOTE: *The pilot should read and thoroughly understand the Columbia 350/400 Airplane Flight Manual (AFM) for limitations, procedures and operational information not contained in this Cockpit Reference Guide. The Columbia 350/400 AFM always takes precedence over the information found in this guide.*



NOTE: *Speed ranges and V-speeds shown in this guide are for example only. Refer to the AFM for values pertaining to the Columbia 350 and Columbia 400.*

1.1 PFD/MFD CONTROLS

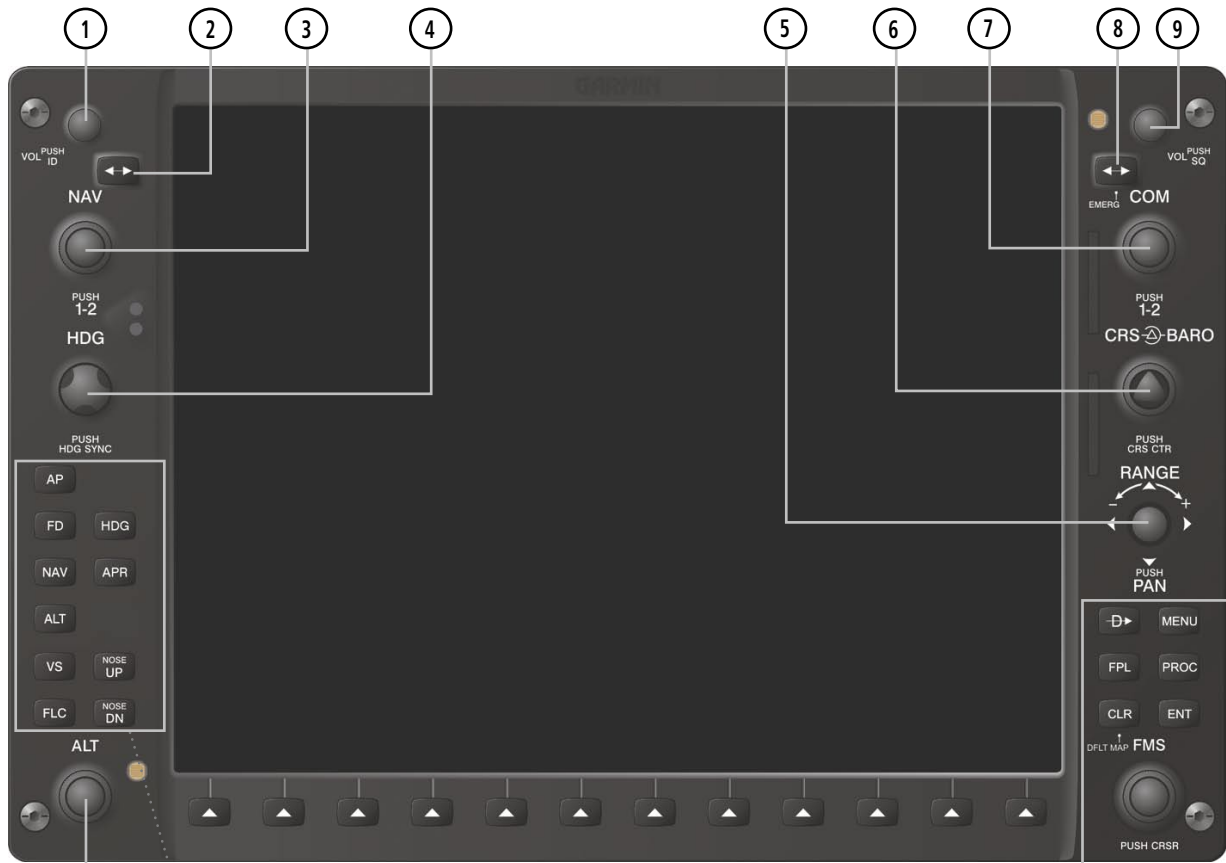
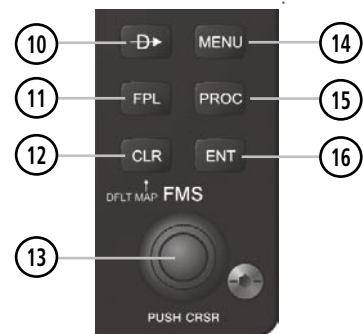
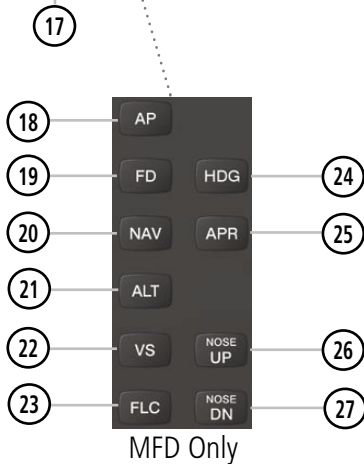

Figure 1-1 PFD/MFD Controls



PFD and MFD controls function the same with the exception of the dedicated Automatic Flight Control System (AFCS) keys located only on the MFD bezel.

(1) NAV VOL/ID Knob – Controls the NAV audio level. Press to turn the Morse code identifier ON and OFF. Volume level is shown in the field as a percentage.

(2) NAV Frequency Transfer Key – Switches the standby and active NAV frequencies.

(3) Dual NAV Knob – Tunes the MHz (large knob) and kHz (small knob) standby frequencies for the NAV receiver. Press to move the tuning cursor (light blue box) between the NAV1 and NAV2 fields.

(4) Heading Knob – Turn to manually select a heading on the HSI. When pressed, it synchronizes the heading bug with the compass lubber line. Selected Heading provides the heading reference to the Flight Director while operating in Heading Select mode.

(5) Joystick – Changes the map range (distance top to bottom of map display) when rotated. Activates the map pointer when pressed.

(6) CRS/BARO Knob – The large knob sets the altimeter barometric pressure and the small knob adjusts the course. The course is only adjustable when the HSI is in VOR1, VOR2, or OBS/SUSP mode. Pressing this knob centers the CDI on the currently selected VOR. Selected Course provides course reference to the Flight Director when operating in Navigation and Approach modes.

(7) Dual COM Knob – Tunes the MHz (large knob) and kHz (small knob) standby frequencies for the COM transceiver. Pressing this knob moves the tuning cursor (light blue box) between the COM1 and COM2 fields.

(8) COM Frequency Transfer Key – Switches the standby and active COM frequencies. Pressing and holding this key for two seconds automatically tunes the emergency frequency (121.5 MHz) in the active frequency field.

(9) COM VOL/SQ Knob – Controls COM audio level. Pressing this knob turns the COM automatic squelch ON and OFF. Audio volume level is shown in the field as a percentage.

(10) Direct-to Key – Allows the user to enter a destination waypoint and establish a direct course to the selected destination (specified by the identifier, chosen from the active route, or taken from the map pointer position).

(11) FPL Key – Displays the active Flight Plan Page for creating and editing the active flight plan, or for accessing stored flight plans.

(12) CLR Key (DFLT MAP) – Erases information, cancels an entry, or removes page menus. To display the Navigation Map Page immediately, press and hold **CLR** (MFD only).

(13) Dual FMS Knob – Used to select the page to be viewed (only on the MFD). The large knob selects a page group (MAP, WPT, AUX, NRST), while the small knob selects a specific page within the page group. Pressing the small knob turns the selection cursor ON and OFF. When the cursor is ON, data may be entered in the different windows using the small and large knobs. The large knob is used to move the cursor on the page, while the small knob is used to select individual characters for the highlighted cursor location. When the G1000 displays a list that is too long for the display screen, a scroll bar appears along the right side of the display, indicating the availability of additional items within the selected category. Press the small **FMS** Knob to activate the cursor and turn the large **FMS** Knob to scroll through the list.

(14) MENU Key – Displays a context-sensitive list of options. This list allows the user to access additional features, or to make setting changes that relate to certain pages.

(15) PROC Key – Selects approaches, departures and arrivals from the flight plan. If a flight plan is used, available procedures for the departure and/or arrival airport are automatically suggested. If a flight plan is not used, the desired airport and the desired procedure may be selected. This key selects IFR departure procedures (DPs), arrival procedures (STARs) and approaches (IAPs) from the database and loads them into the active flight plan.

(16) ENT Key – Accepts a menu selection or data entry. This key is used to approve an operation or complete data entry. It is also used to confirm selections and information entries.

(17) Dual ALT Knob – Sets the selected altitude in the box located above the Altimeter. The large knob selects the thousands, while the small knob selects the hundreds. Altitude Select is used by the Automatic Flight Control System in certain modes, in addition to the standard G1000 Altitude Alerter function.

(18) AP Key – Engages/disengages the Autopilot and Flight Director. Pressing the **AP** Key activates the Flight Director and engages the Autopilot in the default pitch axis and roll axis modes. Pressing the **AP** Key again disengages the autopilot and deactivates the Flight Director.

(19) FD Key – Activates/deactivates the Flight Director only. Pressing the **FD** Key turns on the Flight Director in the default pitch axis and roll axis modes. Pressing the **FD** Key again deactivates the Flight Director and removes the command bars, unless the Autopilot is engaged. If the Autopilot is engaged, the **FD** Key is disabled.

(20) NAV Key – Selects/deselects the Navigation mode.

(21) ALT Key – Selects/deselects the Altitude Hold mode.

(22) VS Key – Selects/deselects the Vertical Speed mode.

(23) FLC Key – Selects/deselects the Flight Level Change mode.

(24) HDG Key – Selects/deselects the Heading Select mode.

(25) APR Key – Selects/deselects the Approach mode.

(26, 27) NOSE UP/NOSE DN Keys – Controls the active pitch reference for the Pitch Hold, Vertical Speed, and Flight Level Change modes.

1.2 GCU 476 CONTROLS

The indicators above the **PFD**, **MFD**, **NAV**, and **COM** Keys are lit when the respective control mode

key is pressed. The unit is in MFD Control Mode by default, until the PFD Control Mode selection key is pressed.

Many of the controls duplicate the controls on the PFD and MFD. The discussions later in this manual are centered around using the controls on the PFD and/or MFD. When reading these discussions, keep in mind that many of the operations may also be performed on the GCU 476.



Figure 1-2 MFD/PFD Control Unit (GCU 476)

(1) FPL Key – Displays the active Flight Plan Page for creating and editing the active flight plan.

(2) Direct-to Key – Allows the user to enter a destination waypoint and establish a direct course to the selected

destination (the destination is either specified by the identifier, chosen from the active route, or taken from the map pointer position).

(3) MENU Key – Displays a context-sensitive list of options. This list allows the user to access additional features or make setting changes that relate to particular pages.

(4) PROC Key – Gives access to IFR departure procedures (DPs), arrival procedures (STARs) and approach procedures (IAPs) for a flight plan. If a flight plan is used, available procedures for the departure and/or arrival airport are automatically suggested and can be loaded into the active flight plan. If a flight plan is not used, both the desired airport and the desired procedure may be selected.

(5) Joystick – Changes the map range (distance top to bottom of map display) when rotated; activates the map pointer when pressed.

(6) Alphanumeric Keys – Allow data entry without using the GDU **FMS** Knob to select individual characters.

(7) BKSP Key – Moves the cursor back one character space.

(8) SPC Key – Adds a space.

(9) ENT Key – Validates or confirms a menu selection or data entry.

(10) CLR Key – Erases information, cancels entries, or removes page menus. Press and hold to immediately display the Navigation Map Page.

(11) SEL Key – The center of this key activates the selected softkey, while the right and left arrows move the softkey selection box (light blue box around the softkey label) to the right and left, respectively.

(12) Decimal Key – Enters a decimal point.

(13) Plus-Minus (±) Key – Switches entry between the + and - characters.

(14) NAV Key – Selects NAV Radio Control Mode. The **FMS** Knob will now control the NAV radios.

(15) COM Key – Selects COM Radio Control Mode. The **FMS** Knob will now control the COM radios.

(16) Frequency Transfer Key – Switches between active and standby selected COM or NAV tuning frequencies. Pressing and holding this key while in COM radio control mode tunes the COM radio to 121.50 MHz, the emergency COM frequency.

(17) PFD Key – Selects PFD Control Mode. The **FMS** Knob will now control PFD functions.

(18) MFD Key – Selects MFD Control Mode. The **FMS** Knob will now control MFD functions.

(19) Dual FMS-NAV/COM Knob (Multifunction Control Knob) – With the MFD indicator illuminated, the **FMS-NAV/COM** Knob performs the same functions as a the **FMS**, **NAV**, and **COM** Knobs on the MFD.

With the PFD indicator illuminated, the **FMS-NAV/COM** Knob performs the same functions as a the **FMS**, **NAV**, and **COM** Knobs on the PFD.

1.3 PFD SOFTKEYS

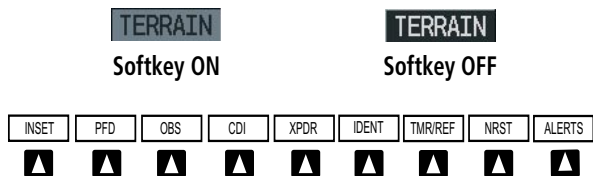

Figure 1-3 PFD Top Level Softkeys

INSET – Select to display the Inset Map in the lower left corner of the PFD.

OFF – Select to remove the Inset Map.

DCLTR (3) – Select momentarily to select the desired amount of map detail. The declutter level appears adjacent to the **DCLTR** Softkey.

- No declutter: All map features are visible
- Declutter – 1: Removes land data
- Declutter – 2: Removes land and SUA data
- Declutter – 3: Removes everything except the active flight plan

TRAFFIC – Select to display traffic on the inset map.

TOPO – Select to display topographical data (i.e., coastlines, terrain, rivers, lakes) and elevation scale on the Inset Map.

TERRAIN – Select to display terrain information on the Inset Map.

STRMSCP (optional) – Select to display the Stormscope lightning data on the Inset Map (within a 200 nm radius of the aircraft).

NEXRAD (optional) – Select to display NEXRAD precipitation data on the Inset Map.

XM LTNG (optional) – Select to display the XM Radio lightning data on the Inset Map.

BACK – Select to return to the previous level softkey configuration.

ALERTS – Select to display the Alerts Window.

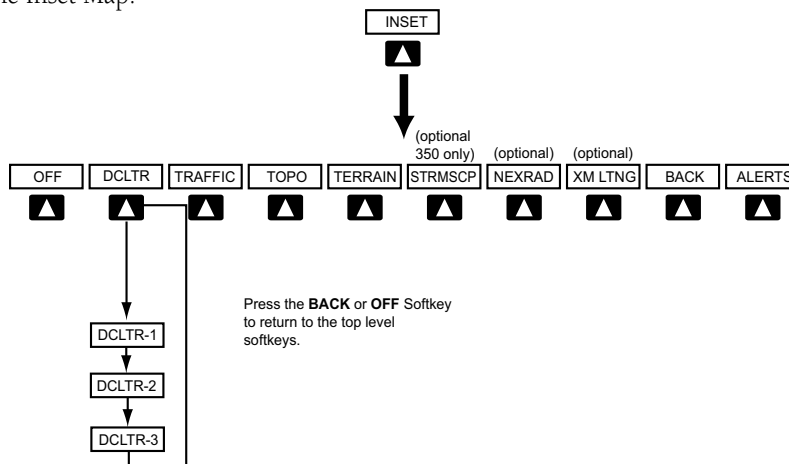

Figure 1-4 PFD Softkey Flow Chart – 1

PFD – Select to display the additional softkeys for additional configuration of the PFD.

METRIC – Select to display the current and reference altitudes in meters, in addition to feet. Selecting the metric softkey also changes the barometric setting to hectopascals.

DFLTS – Select to reset default settings on the PFD.

BRG1 (bearing) – Select to cycle through the following information:

NAVI – Displays NAV1 waypoint frequency or identifier in the BRG1 Information Window.

GPS – Displays GPS waypoint identifier and GPS distance information in the BRG1 Information Window.

OFF – Removes the BRG1 Information Window.

360 HSI – Select to display the 360° compass rose.

ARC HSI – Select to display the 140° viewable arc.

BRG2 (bearing) – Select to cycle through the following information:

NAV2 – Displays NAV2 waypoint frequency or identifier in the BRG2 Information Window.

GPS – Displays GPS waypoint identifier and GPS distance information in the BRG2 Information Window.

OFF – Removes the BRG2 Information Window.

STD BARO – Select to set the barometric pressure to 29.92 inches of mercury (1013 hPa by selecting the **METRIC** Softkey).

BACK – Select to return to the previous level softkeys.

ALERTS – Select to display the Alerts Window.

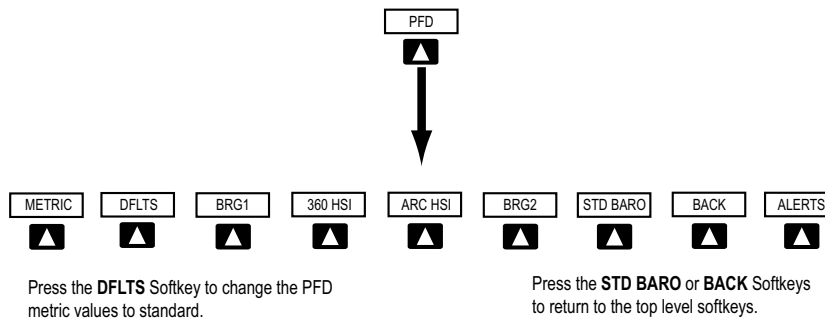

Figure 1-5 PFD Softkey Flow Chart – 2

SECTION 1 SYSTEM OVERVIEW

OBS – Select to select OBS mode on the CDI when navigating by GPS (only available with active leg).

CDI – Select to change navigation mode on the CDI between GPS, VOR1, and VOR2.

XPDR – Select to display the transponder mode selection softkeys.

STBY – Select to select standby mode.

ON – Select to select mode A.

ALT – Select to select altitude reporting mode.

VFR – Select to automatically squawk 1200 (only in the U.S.A., refer to ICAO standards for VFR codes in other countries).

CODE – Select to display transponder code selection softkeys 0-7.

0 through 7 – Select numbers to enter code.

IDENT – Select to provide special aircraft position identification to Air Traffic Control (ATC).

BKSP – Select to remove numbers entered one at a time.

BACK – Select to return to the previous level softkeys.

IDENT – Select to provide special aircraft position identification to Air Traffic Control (ATC).

BACK – Select to return to the previous level softkeys.

ALERTS – Select to display the Alerts Window.

IDENT – Select to provide special aircraft position identification to Air Traffic Control (ATC).

TMR/REF – Select to display the Timer/References Window.

NRST – Select to display the Nearest Airports Window.

ALERTS – Select to display the Alerts Window.

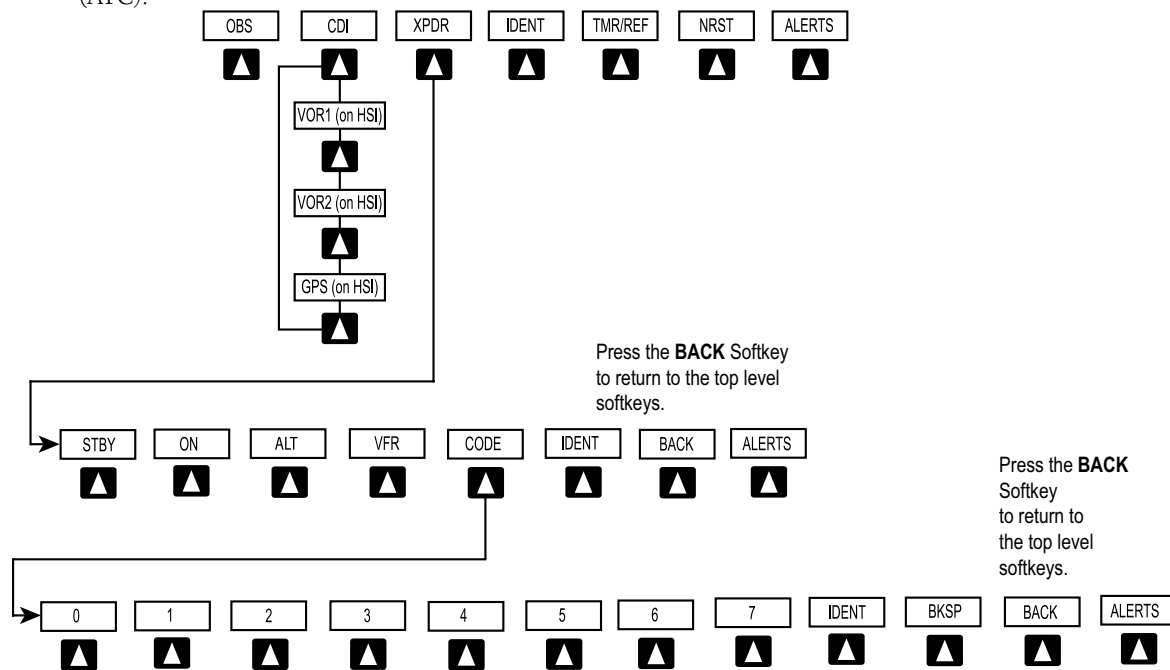

Figure 1-6 PFD Softkey Flow Chart – 3

1.4 MFD SOFTKEYS

ENGINE – Selecting this softkey makes available the Engine Display functions. Refer to the Engine Indication System section.

MAP – Selecting this softkey enables the following softkeys:

TRAFFIC – Selecting this softkey displays/removes Traffic on the Navigation Map.

TOPO – Selecting this softkey displays or removes topographic information on the Navigation Map.

TERRAIN – Selecting this softkey displays/removes terrain and obstacle data on the Navigation Map.

STRMSCP (optional) – Selecting this softkey displays/removes Stormscope lightning data on the Navigation Map.

NEXRAD (optional) – Selecting this softkey displays/removes precipitation data on the Navigation Map.

XM LTNG (optional) – Selecting this softkey displays/removes XM Radio lightning data on the Navigation Map.

BACK – Selecting this softkey displays the ENGINE and MAP top level softkeys.

DCLTR (declutter) – Selecting this softkey removes map information in three levels.

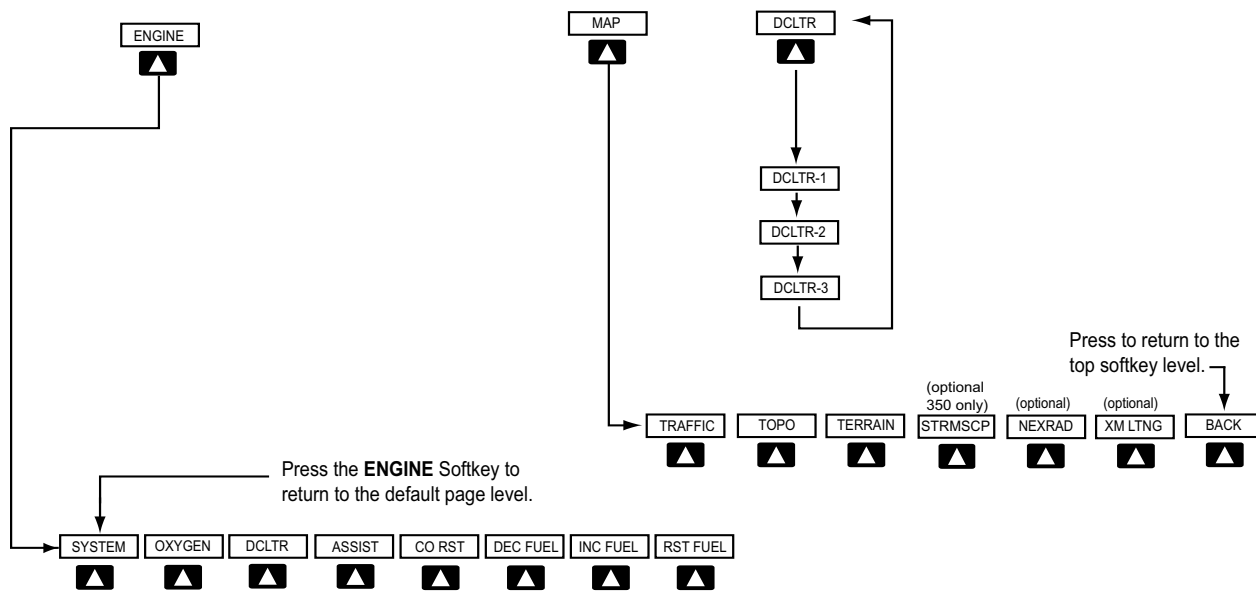

Figure 1-7 MFD Softkeys

1.5 MFD PAGE GROUPS

- 1) Turn the large **FMS** Knob until the desired page group is selected.
- 2) Turn the small **FMS** Knob to select pages within the group. See Figure 1-8.

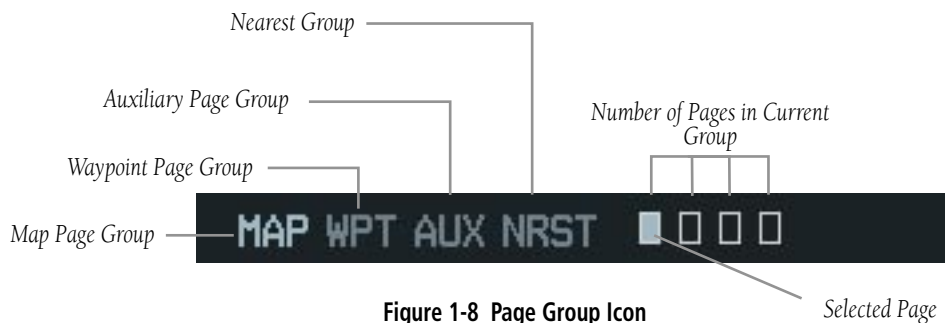

Figure 1-8 Page Group Icon

1.6 BACKLIGHTING

Manually adjust the backlight for the PFD and MFD:

- 1) Press the **MENU** Key on the PFD to display the PFD Setup Menu Window.
- 2) Press the small **FMS** Knob to activate the cursor. 'PFD DSPL > AUTO' is now highlighted.
- 3) Turn the small **FMS** Knob to display the selection window.
- 4) Turn the **FMS** Knob to select 'MANUAL', then press the **ENT** Key.
- 5) With the intensity value now highlighted, turn the small **FMS** Knob to select the desired backlighting.
- 6) Turn the large **FMS** Knob to highlight 'MFD DSPL > AUTO' and repeat steps 3 through 5.

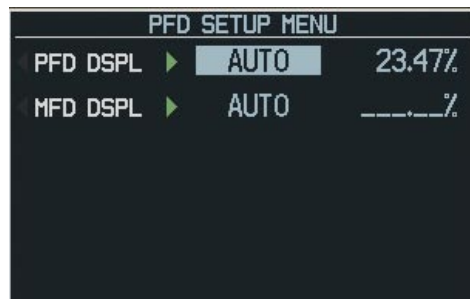

Figure 1-9 PFD Setup Menu Window

1.7 DATABASE UPDATES

Aviation Database Update



NOTE: The display downloads the aviation database and stores it internally. The aviation database SD card is not required to remain in the display after the update.

- 1) With the G1000 System OFF, insert the aviation database update SD card into the top card slot of the PFD (Label of SD card facing left).
- 2) Turn the G1000 System ON. This prompt is displayed on the upper left corner of the PFD:

```
DO YOU WANT TO UPDATE THE AVIATION DATABASE?
PRESS CLR FOR NO AND ENT FOR YES
YOU HAVE 30 SECONDS BEFORE NO IS RETURNED
```

Figure 1-10 Database Update Prompt

- 3) Press the **ENT** Key to confirm the database updated. This prompt is displayed:

```
DO YOU WANT TO UPDATE THE AVIATION DATABASE?
PRESS CLR FOR NO AND ENT FOR YES
YOU HAVE 30 SECONDS BEFORE NO IS RETURNED
UPDATING AVIATION DATABASE
.
UPDATED 1 FILES SUCCESSFULLY!
```

Figure 1-11 Database Update Confirmation

- 4) After the update completes, the PFD starts in normal mode. Remove the aviation database update SD card from the PFD.
- 5) Turn the G1000 System OFF.
- 6) Repeat steps 1 through 4 for the MFD. The MFD and PFD aviation databases are now updated.

- 7) Verify that the correct update cycle is loaded during startup of the MFD.

Terrain and Obstacle Database Updates



NOTE: The data contained in the terrain and obstacle databases comes from government agencies. Garmin accurately processes and cross-validates the data, but cannot guarantee the accuracy and completeness of the data.



NOTE: Obstacles 200' and higher are included in the obstacle database. It is very important to note that not all obstacles are necessarily charted and therefore may not be contained in the obstacle database.

These databases are not stored internally in the MFD or PFD. Supplemental Data Cards containing identical database versions must be kept in both displays to retain terrain and obstacle data. A Supplemental Data Card should be inserted into the bottom card slot of the PFD and MFD.



NOTE: If the Supplemental Data Card is removed from the display, the **TOPO** and **TERRAIN** softkeys are not functional and are grayed out on the MFD Map Page.

- 1) Insert one card in the bottom card slot of the MFD and one in the bottom card slot of the PFD.
- 2) Apply power to the G1000 System. View the MFD power-up splash screen. Check that the Terrain and Obstacle databases are initialized and displayed on the scrolling window of the splash screen.

- 3) Acknowledge the Power-up Page agreement by pressing the **ENT** Key or the right most softkey.
- 4) At the MAP – NAVIGATION MAP page, select the **MAP** Softkey and check to make sure that the **TOPO** and **TERRAIN** softkeys are functional (not grayed out).
- 5) Power down the G1000.

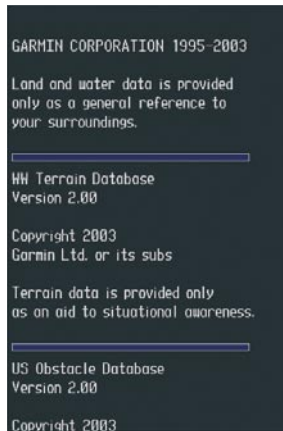
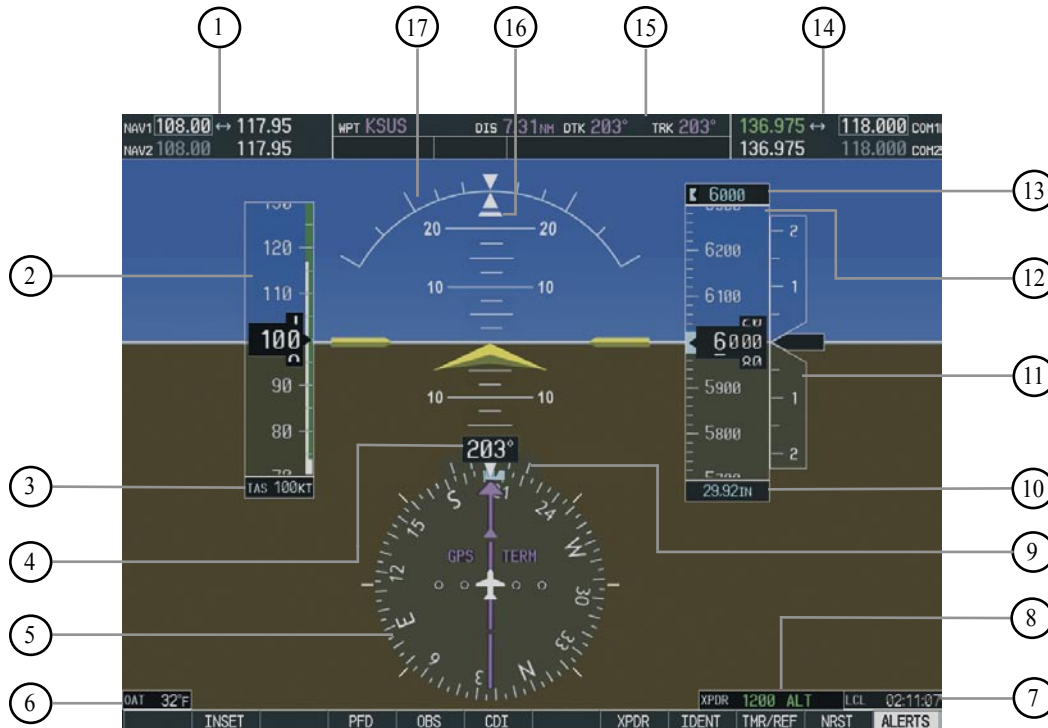

Figure 1-12 Power-Up Splash Screen Window

SECTION 2: FLIGHT INSTRUMENTS

The following discussions pertain to the Primary Flight Display, unless otherwise indicated.



- | | |
|----------------------------------|----------------------------|
| ① NAV Frequency Box | ⑨ Turn Rate Indicator |
| ② Airspeed Indicator | ⑩ Barometric Setting Box |
| ③ True Airspeed Box | ⑪ Vertical Speed Indicator |
| ④ Heading Box | ⑫ Altimeter |
| ⑤ Horizontal Situation Indicator | ⑬ Selected Altitude Box |
| ⑥ Outside Air Temperature Box | ⑭ COM Frequency Box |
| ⑦ System Time Box | ⑮ Navigation Status Box |
| ⑧ Transponder Status Box | ⑯ Slip/Skid Indicator |
| | ⑰ Attitude Indicator |

Figure 2-1 Default PFD Information

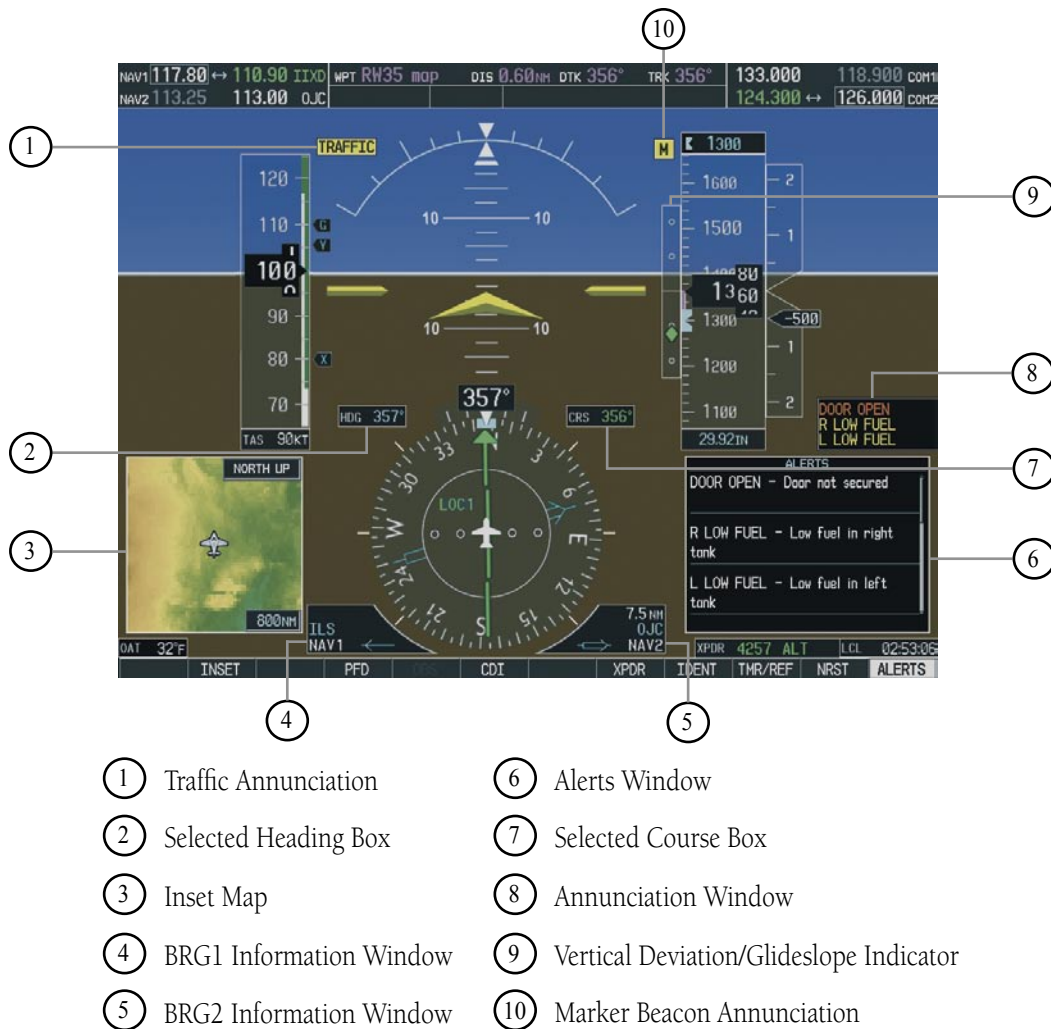

Figure 2-2 Additional PFD Information



Figure 2-3 PFD Navigation Status Box

2.1 AIRSPEED INDICATOR

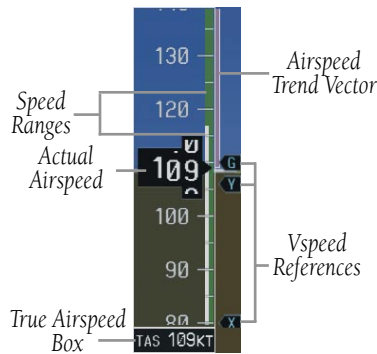

Figure 2-4 Airspeed Indicator

Speed Indication

The indicated airspeed is displayed inside the black pointer. The pointer will become red upon reaching Vne. At altitudes above 12,000 feet, Vno and Vne will vary with altitude. Refer to the Airplane Flight Manual (AFM).

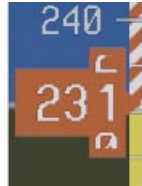

Figure 2-5 Red Pointer at Vne

Speed Ranges

The color coded speed range strip denotes flaps operating range, normal operating range, and never exceed speed (Vne). A red range is also present for low speed awareness. At altitudes above 12,000 feet, caution and excessive speed range markings will vary with altitude. Refer to the Airplane Flight Manual (AFM) for airspeed limitations and indicator markings.

Airspeed Trend Vector

The end of the trend vector displays approximately what the airspeed will be in 6 seconds if the current rate of acceleration/deceleration is maintained.

Vspeed References

Vspeed References are turned on or off in the Timer/References Window. Select the **TMR/REF** Softkey to display the window. When active (**ON**), the Vsps are displayed at their respective locations to the right of the airspeed scale. To activate the Vspeed References, display the Timer/Reference Window and turn the large **FMS** Knob to place the cursor in the ON/OFF field. Turn the small **FMS** Knob to select **ON** or **OFF**.

2.2 ATTITUDE INDICATOR

The Slip/Skid Indicator is located under the Roll Pointer and moves laterally away from the pointer to indicate lateral acceleration. One Slip/Skid indicator displacement is equal to one ball displacement when compared to a traditional slip/skid indicator.

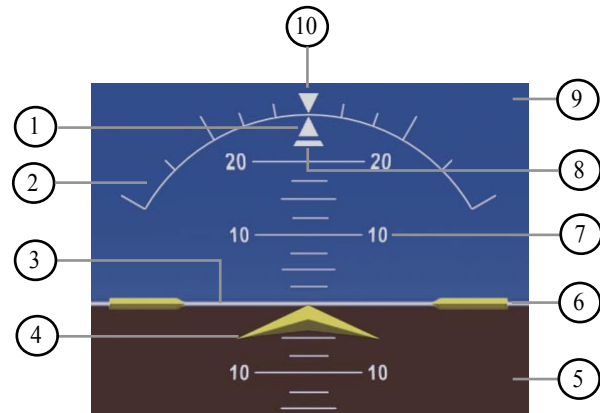

- ① Roll Pointer
- ② Roll Scale
- ③ Horizon Line
- ④ Aircraft Symbol
- ⑤ Land Representation
- ⑥ Aircraft Wing Tips
- ⑦ Pitch Scale
- ⑧ Slip/Skid Indicator
- ⑨ Sky Representation
- ⑩ Roll Scale Zero

Figure 2-6 Attitude Indicator

2.3 ALTIMETER

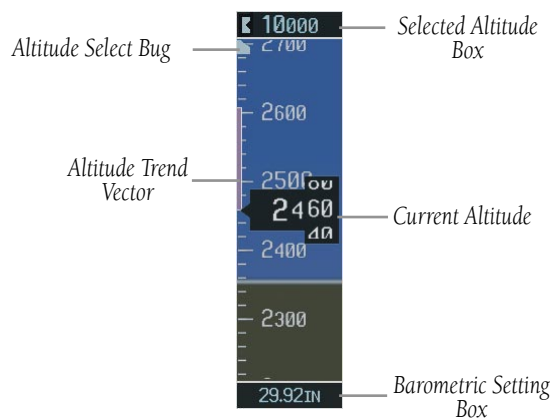

Figure 2-7 Altimeter

Altitude Select Bug

The Altitude Select Bug is displayed at the selected altitude or, if the selected altitude is beyond the altitudes currently displayed, the bug is displayed at the top or bottom of the display (whichever is closest to the selected altitude).

Set the Selected Altitude Bug:

Turn the **ALT** Knobs to set the Altitude Select Bug. The small **ALT** Knob sets the hundreds and the large **ALT** Knob sets the thousands. This altitude also appears in the Selected Altitude Box above the Altimeter.

Altitude Trend Vector

The end of the trend vector displays approximately what the altitude will be in 6 seconds if the current rate of vertical speed is maintained.

Barometric Setting Box

To set barometric pressure, turn the **BARO** Knob to select the desired setting.

Altitude Alerting



Figure 2-8 Altitude Alerting Visual Annunciations

Visual annunciations appear in the Selected Altitude Box. Whenever the Selected Altitude is changed, the Altitude Alerter is reset. The Altitude Alerter is independent of the Automatic Flight Control System.

An aural tone is heard when the aircraft is within 200 feet of acquiring the selected altitude or when deviating beyond 200 feet of the acquired selected altitude.

Barometric Minimum Descent Altitude

The desired barometric minimum descent altitude (MDA, or Decision Height, DH) can be set in the Timer/References Window.

Visual annunciations alert the pilot when approaching the MDA:

- When the aircraft altitude descends to within 2500 feet of the MDA setting, the Barometric Minimum Box appears with the altitude in light blue text. The bug appears on the tape in light blue once in range.
- When the aircraft passes through 100 feet of the MDA, the bug and text turn white.
- Once the aircraft descends past the MDA, the bug and text turn yellow and the aural alert, “Minimums Minimums”, is generated.

Alerting is inhibited while the aircraft is on the ground. If the aircraft climbs after having reached the MDA, once it reaches 50 feet above the MDA, alerting is disabled.

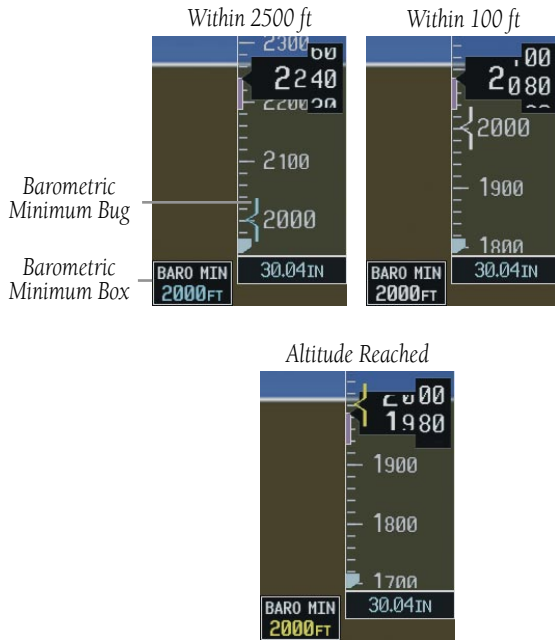

Figure 2-9 Barometric Minimum Descent Altitude Alerting Visual Annunciations

2.4 VERTICAL DEVIATION/GLIDESLOPE INDICATOR

The Vertical Deviation/Glideslope Indicator appears when an ILS is tuned in the active NAV field.

2.5 MARKER BEACON ANNUNCIATIONS

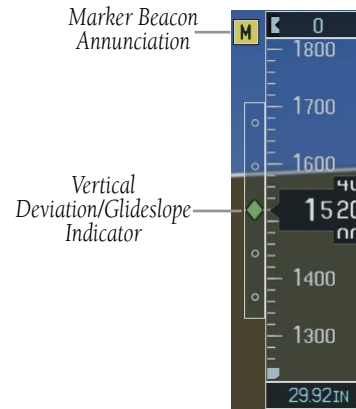

Figure 2-10 Marker Beacon and Vertical Deviation

2.6 VERTICAL SPEED INDICATOR

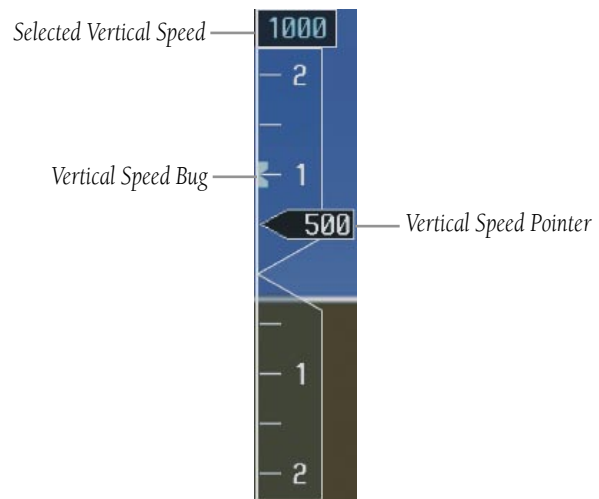
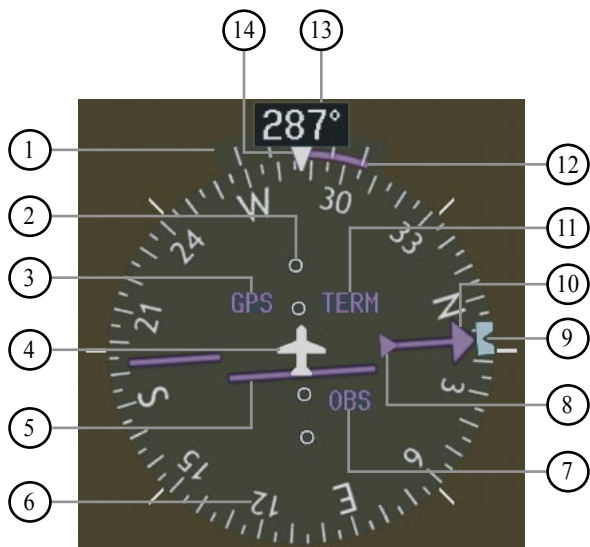

Figure 2-11 Vertical Speed Indicator

The actual vertical speed is displayed inside the pointer.

When the Flight Director is placed in Vertical Speed Mode (by pressing the **VS** Key) the Vertical Speed Bug is displayed. Press the **NOSE UP** or **NOSE DN** Key to adjust.

2.7 HORIZONTAL SITUATION INDICATOR (HSI)



- ① Turn Rate Indicator
- ② Lateral Deviation Scale
- ③ Navigation Source
- ④ Aircraft Symbol
- ⑤ Course Deviation Indicator
- ⑥ Rotating Compass Rose
- ⑦ OBS Mode
- ⑧ TO/FROM Indicator
- ⑨ Heading Bug
- ⑩ Course Pointer
- ⑪ Flight Phase
- ⑫ Turn Rate and Heading Trend Vector
- ⑬ Heading
- ⑭ Lubber Line

Figure 2-12 Horizontal Situation Indicator (360°)

Arc HSI



NOTE: When the Arc HSI is displayed the BRG1 and BRG2 Information Windows and pointers are disabled.



NOTE: If the pilot makes a heading change greater than 105° with respect to the course, the CDI switches to the opposite side of the deviation scale and displays reverse sensing.

The Arc HSI is a 140° expanded section of the compass rose. The Arc contains a Course Pointer arrow, the TO/FROM indicator, a sliding deviation indicator (the TO/FROM and sliding deviation indicators are one and the same), and a deviation scale. Upon station passage, the TO/FROM indicator flips and points to the tail of the aircraft, just like the conventional TO/FROM flag. Depending on the navigation source, the CDI on the Arc HSI can appear in two different ways:

- GPS, OBS, VOR – Arrowhead
- Localizer – Diamond

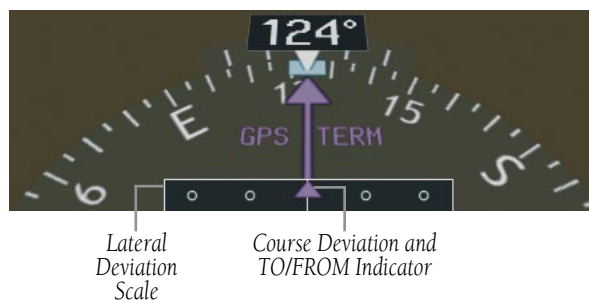

Figure 2-13 Arc HSI

Turn Rate Indicator and Heading Trend Vector

Tick marks to the left and right of the lubber line denote half-standard and standard turn rates. A magenta turn rate trend vector shows the current turn rate. The

end of the trend vector gives the heading predicted in six seconds, based on the present turn rate. At rates greater than 4 deg/sec, an arrowhead appears at the end of the magenta trend vector and the prediction is no longer valid.

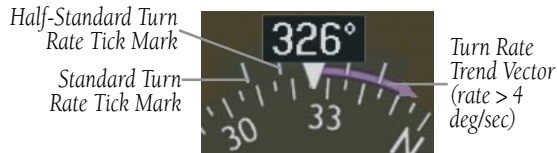

Figure 2-14 Turn Rate Indicator and Trend Vector



Figure 2-15 Standard-Rate Turn Indication

Course Pointer

The Course Pointer is a single line arrow (GPS, VOR1 and LOC1) or double line arrow (VOR2 and LOC2) which points in the direction of the set course.



Figure 2-16 Course Pointer

Course Deviation Indicator (CDI)

The CDI scale automatically adjusts to the current phase of flight (enroute 5.0 nm, terminal area 1.0 nm, or approach 0.3 nm). Scaling may be selected manually from the MFD System Setup Page. See System Setup in the G1000 Pilot's Guide for more details.

Bearing Pointers and Information Windows

Selecting the **PFD** Softkey provides access to the **BRG1** and **BRG2** Softkeys. The BRG1 Pointer is a single line pointer. The BRG2 Pointer is a double line pointer.

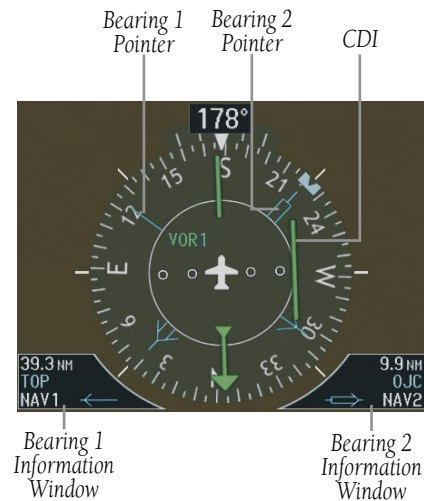

Figure 2-17 HSI with Bearing Information

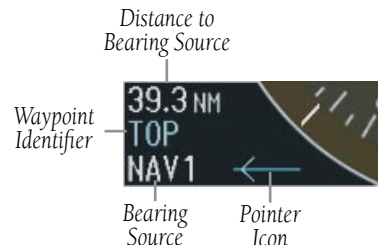

Figure 2-18 BRG1 Information Window

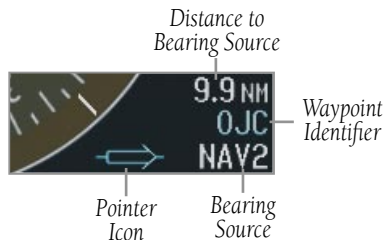

Figure 2-19 BRG2 Information Window

Navigation Source

Change navigation sources:

- 1) Select the **CDI** Softkey to change from GPS to VOR1/LOC1.
- 2) Select the **CDI** Softkey again to change from VOR1/LOC1 to VOR2/LOC2.
- 3) Select the **CDI** Softkey a third time to return to GPS.

When using GPS as the navigation source, the following may appear:

- **INTEG** – GPS information is either not present or is invalid for navigation use
- **WARN** – GPS detects a position error
- **SUSP** – Displayed when in OBS Mode indicating GPS waypoint sequencing is suspended.



Figure 2-19 GPS INTEG, GPS SUSP, LOC1 and VOR2

Enable/disable OBS mode while navigating with GPS:

- 1) Select the **OBS** Softkey to select OBS Mode.
- 2) Turn the **CRS** Knob to select the desired course TO/FROM the waypoint.
- 3) Select the **OBS** Softkey again to return to normal operation.



NOTE: The **OBS** Softkey is only displayed when navigating an active leg using GPS.

SECTION 3: ENGINE INDICATION SYSTEM (EIS)

The Engine Instrument Display is displayed on the left side of the MFD.

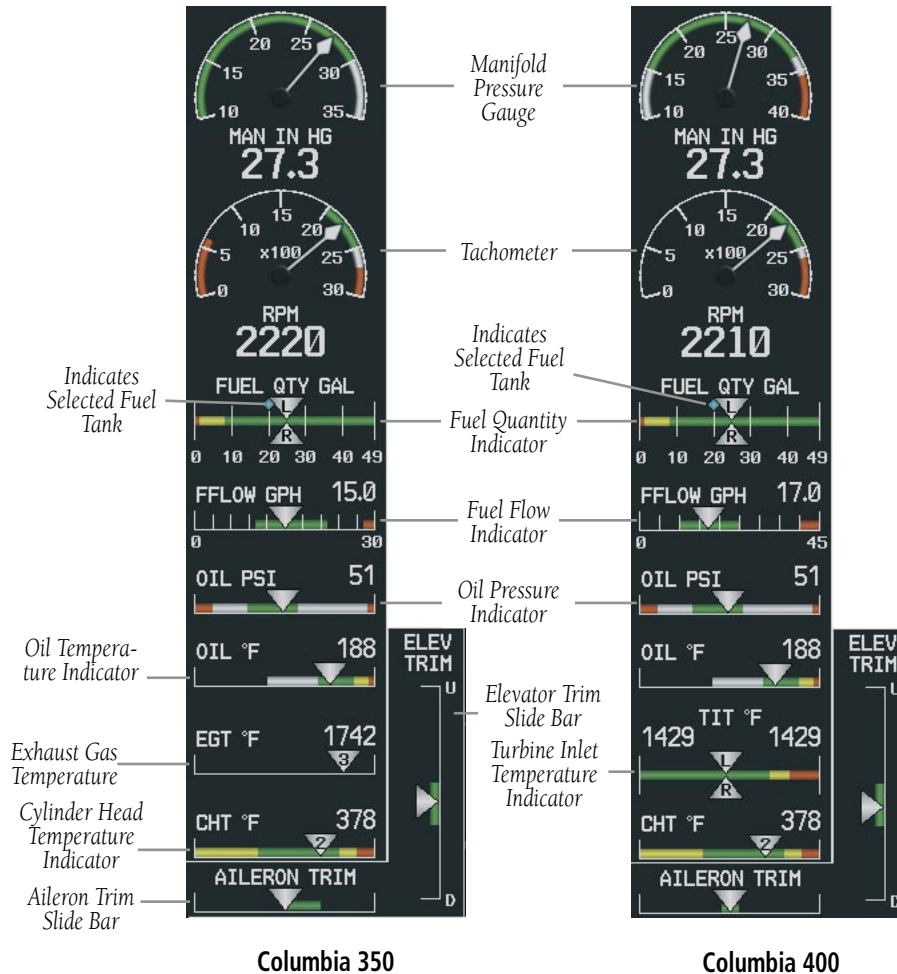

Figure 3-1 Engine Instrument Display

3.1 EIS DISPLAY

Selecting the **SYSTEM** Softkey on the MFD accesses the Engine Indication System (EIS) Display. For all instruments, green indicates the acceptable operating range; yellow and red indicate caution and warning, respectively.

Oxygen System (Optional)

Selecting the **OXYGEN** Softkey on the MFD turns the oxygen system on or off. If no oxygen system is installed, the oxygen gauges will be blank.

- **Oxygen Quantity (OXY QTY PSI)** – Amount of remaining oxygen in terms of pressure.
- **Oxygen Outlet Pressure (OXY OUTLET PSI)** – Oxygen outlet pressure in pounds per square inch (psi)

Trim

Correct takeoff aileron and elevator trim positions are indicated by the green boxes.

Carbon Monoxide Detection

If carbon monoxide in the cabin becomes too high (above 50 ppm), a flashing annunciation will be displayed in the lower left of the EIS System Display as shown in Figure 3-2. The current amount of CO is displayed in parts-per-million. A warning annunciation will also be displayed on the PFD in the Annunciations Window and an aural warning will be generated.



Figure 3-2 EIS Display (Columbia 400 shown)

3.2 ENGINE LEANING ASSIST DISPLAY

Engine Leaning for the Columbia 350



NOTE: The Columbia 350 Airplane Flight Manual (AFM) supersedes information found in this section.

Leaning for Best Power

- 1) Select the **SYSTEM** Softkey.
- 2) Select the **ASSIST** Softkey.

- 3) Lean the mixture until one of the cylinder's exhaust temperature peaks. This is indicated by '1st' being displayed below the first cylinder to peak. A bar is also displayed at that point on that cylinder's bar graph. See Figure 3-3.
- 4) Richen the mixture until the Δ PEAK temperature is rich by the amount indicated in the Columbia Airplane Flight Manual (AFM).

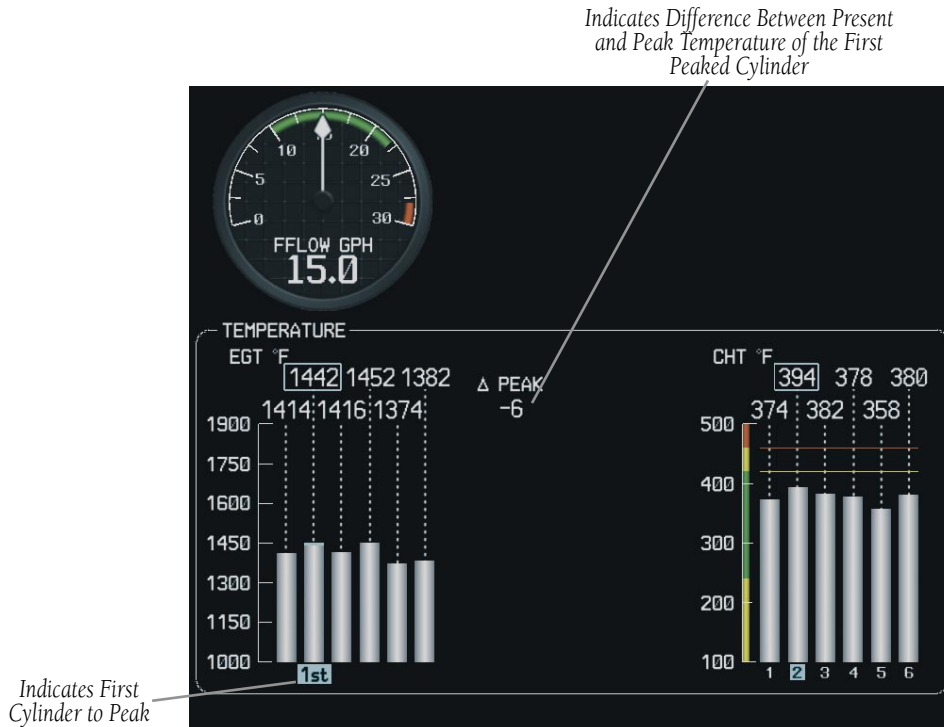

Figure 3-3 Engine Leaning Assist Display - First Peaked Cylinder (Columbia 350)

Leaning for Best Economy

- 1) Select the **SYSTEM** Softkey.
- 2) Select the **ASSIST** Softkey.
- 3) Lean the mixture until one of the cylinder's exhaust temperature peaks. This is indicated by '1st' being displayed below the first cylinder to peak. See Figure 3-3.
- 4) Continue leaning the mixture until the last of the cylinders peaks. This is indicated by 'Last' being displayed below the last peaking cylinder as shown in Figure 3-4.
- 5) Monitor the Δ Peak temperature and continue leaning the mixture until reaching the value indicated in the Columbia Airplane Flight Manual (AFM).

Selecting the **ASSIST** Softkey returns the MFD to the EIS Display. Selecting the **SYSTEM** Softkey exits the Assist Display and returns the MFD to default operation.

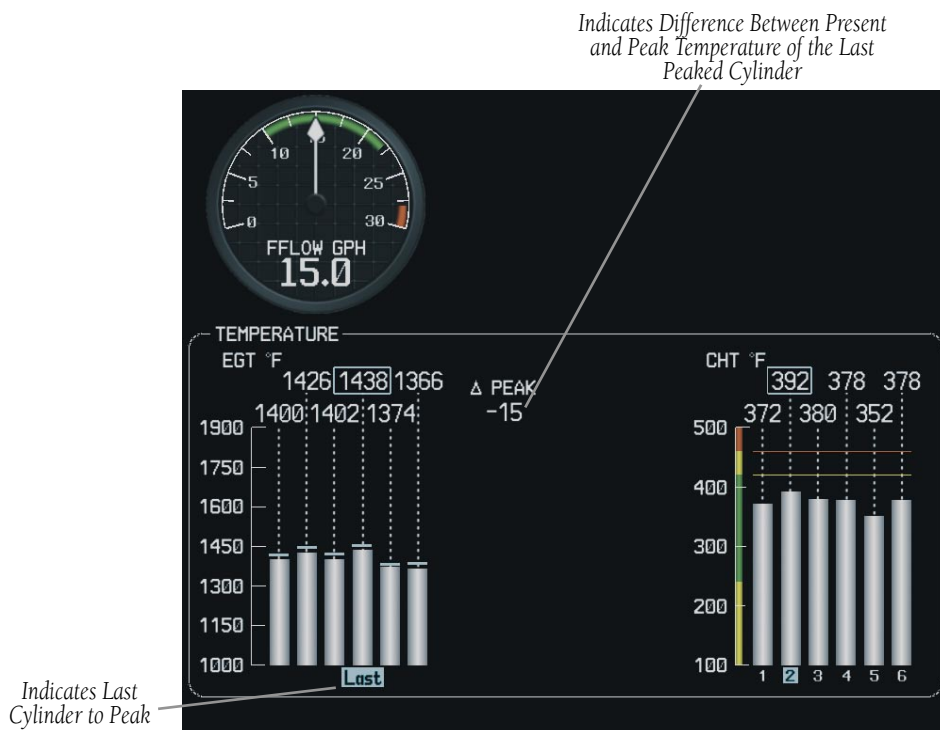

Figure 3-4 Engine Leaning Assist Display - Last Peaked Cylinder (Columbia 350)

Engine Leaning for the Columbia 400



NOTE: The Columbia 400 Airplane Flight Manual (AFM) supersedes information found in this section.

Leaning for Best Power

- 1) Select the **SYSTEM** Softkey.
- 2) Select the **ASSIST** Softkey.
- 3) Lean the mixture to obtain peak temperature on the TIT displays. See Figure 3-5. Refer to the Columbia Airplane Flight Manual (AFM) for more detailed procedures.

- 4) Richen the mixture to obtain the desired delta (Δ) values as specified in the AFM.

Leaning for Best Economy

- 1) Select the **SYSTEM** Softkey.
- 2) Select the **ASSIST** Softkey.
- 3) Lean the mixture to obtain peak temperature on the TIT displays. See Figure 3-5. Refer to the Columbia Airplane Flight Manual (AFM) for more detailed procedures.
- 4) Continue leaning the mixture until the desired delta (Δ) values are obtained as specified in the AFM.

Selecting the **ASSIST** Softkey returns the MFD to the EIS Display. Selecting the **SYSTEM** Softkey exits the Assist Display and returns the MFD to default operation.

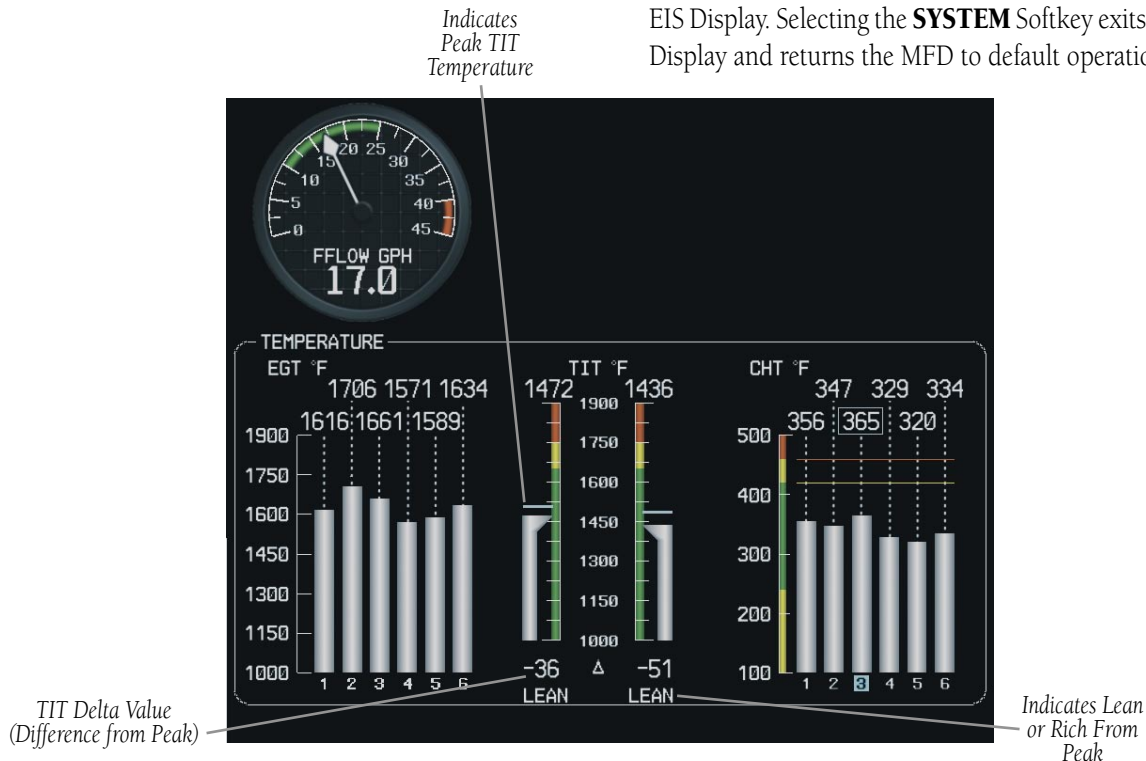

Figure 3-5 Engine Leaning Assist Display (Columbia 400)

3.3 FUEL CALCULATIONS

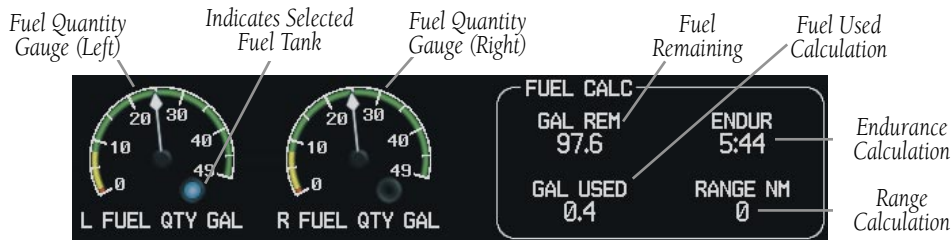

Figure 3-6 EIS Display - Fuel Calculations Group

Fuel used (GAL USED), endurance (ENDUR), and range (RANGE NM) are all calculated based on the last manual adjustment of the fuel remaining (GAL USED).

Measured fuel quantity has no effect on fuel calculations. Fuel calculations are based on sensed fuel flow and the last manual adjustment of the fuel remaining.



NOTE: When full, the Columbia 350/400 has 98 gallons of usable fuel.

The following softkeys allow for adjustment of the remaining fuel quantity.

- **DEC FUEL** – Allows the pilot to decrease the gallons of fuel remaining (GAL REM) in 1-gallon increments
- **INC FUEL** – Allows the pilot to increase the gallons of fuel remaining in 1-gallon increments
- **RST FUEL** – Resets the fuel remaining to 98 gallons.

SECTION 4: NAV/COM AND TRANSPONDER

The NAV/COM controls and frequency boxes are located on the Primary Flight Display and the Multi-Function Display in the same locations. Operations in the following discussions may also be performed with the corresponding controls on the MFD/PFD Control Unit.



Figure 4-1 G1000 VHF NAV/COM Controls (PFD)

SECTION 4 – NAV/COM & TRANSPONDER

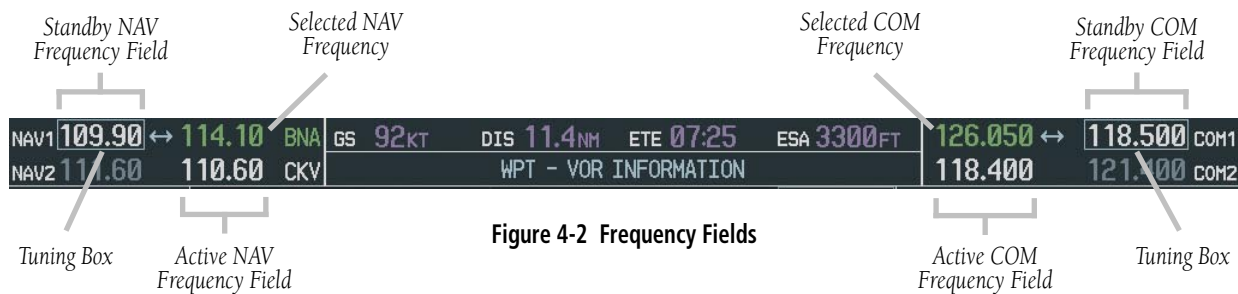

Figure 4-2 Frequency Fields



Figure 4-3 Frequency Transfer Arrow and Tuning Box

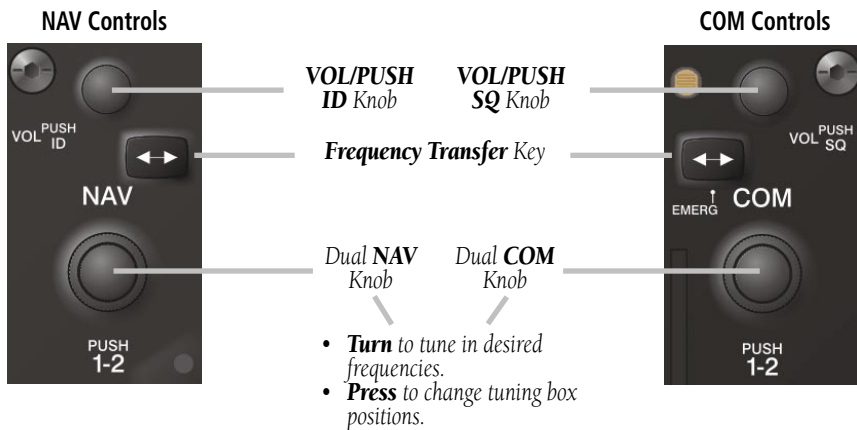

Figure 4-4 NAV/COM Controls

4.1 RADIO STATUS INDICATIONS

- RX – When a COM signal is received, a white 'RX' appears by the active COM frequency during signal reception.
- TX – When a COM radio is transmitting, a white 'TX' indication appears to the right of the corresponding COM frequency.
- ID – When the Morse code identifier is ON for a NAV radio, a white 'ID' indication appears to the left of the corresponding active NAV frequency. The Morse code identifier can be heard if the corresponding NAV radio is selected on the audio panel.



Figure 4-5 Radio Status Indications

4.2 VOLUME

'VOLUME' is displayed in place of the associated radio name (i.e., 'COM1' or 'NAV2') for two seconds after the volume level is last changed. The percentage of maximum volume is displayed in place of the standby frequency selected by the tuning box.



Figure 4-6 COM Volume Level

4.3 AUTOMATIC SQUELCH

Automatic squelch can be disabled for a COM radio by pressing the **COM** Knob to place the tuning box on the desired COM's standby frequency, then by pressing the **VOL/PUSH SQ** Knob.

4.4 QUICKLY ACTIVATING 121.500 MHZ

Pressing and holding the **COM Frequency Transfer** Key for approximately two (2) seconds automatically tunes the selected COM radio to the emergency frequency.

4.5 FREQUENCY AUTO-TUNING

Auto-tuning on the PFD



Figure 4-7 Nearest Airports Window (PFD)

- 1) Select the **NRST** Softkey to display the Nearest Airports Window.
- 2) Turn either **FMS** Knob to highlight the desired frequency.
- 3) Press the **ENT** Key to place the frequency in the standby field of the active COM.
- 4) Press the **Frequency Transfer** Key to place the frequency in the active field.

NAV frequencies are entered automatically in the active NAV frequency field upon approach loading or approach activation.

Auto-tuning on the MFD

Auto-tuning on the MFD is done in much the same way as on the PFD. Use the **FMS** Knobs to select the desired frequency on any of the information pages. Pressing the **ENT** Key then loads the selected frequency in the tuning box as a standby frequency.

4.6 TRANSPONDER

Mode Selection

The **STBY**, **ON**, and **ALT** Softkeys can be accessed by selecting the **XPDR** Softkey.

Ground Mode (Automatic)

GND is displayed when the aircraft is on the ground.



Figure 4-8 Ground Mode

Reply Status

When the transponder sends replies to interrogations, an “R” indication appears momentarily in the reply status field.

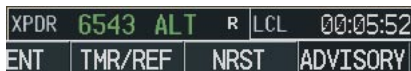

Figure 4-9 Reply Indication

Code Selection

- 1) Select the **XPDR** Softkey to display the transponder Mode Selection softkeys.
- 2) Select the **CODE** Softkey to display the transponder Code Selection softkeys, which includes the digit softkeys.
- 3) Press the appropriate digit softkeys to enter the code in the four-digit code field of the Transponder Status Box. Five seconds after the fourth digit has been entered, the transponder code becomes activated.

When entering a code, select the **BKSP** Softkey as needed to back up and change code digits.

Following is a list of important codes:

- 1200 – VFR code in the U.S. (please refer to the ICAO standards for VFR codes in other countries)
- 7000 – VFR code commonly used in Europe (please refer to the ICAO standards)
- 7500 – Hijack code
- 7600 – Loss of communication code
- 7700 – Emergency code
- 7777 – Military interceptor operations code (NEVER ENTER THIS CODE)
- 0000 – Code for military use (in the U.S.)

SECTION 5: AUDIO PANEL

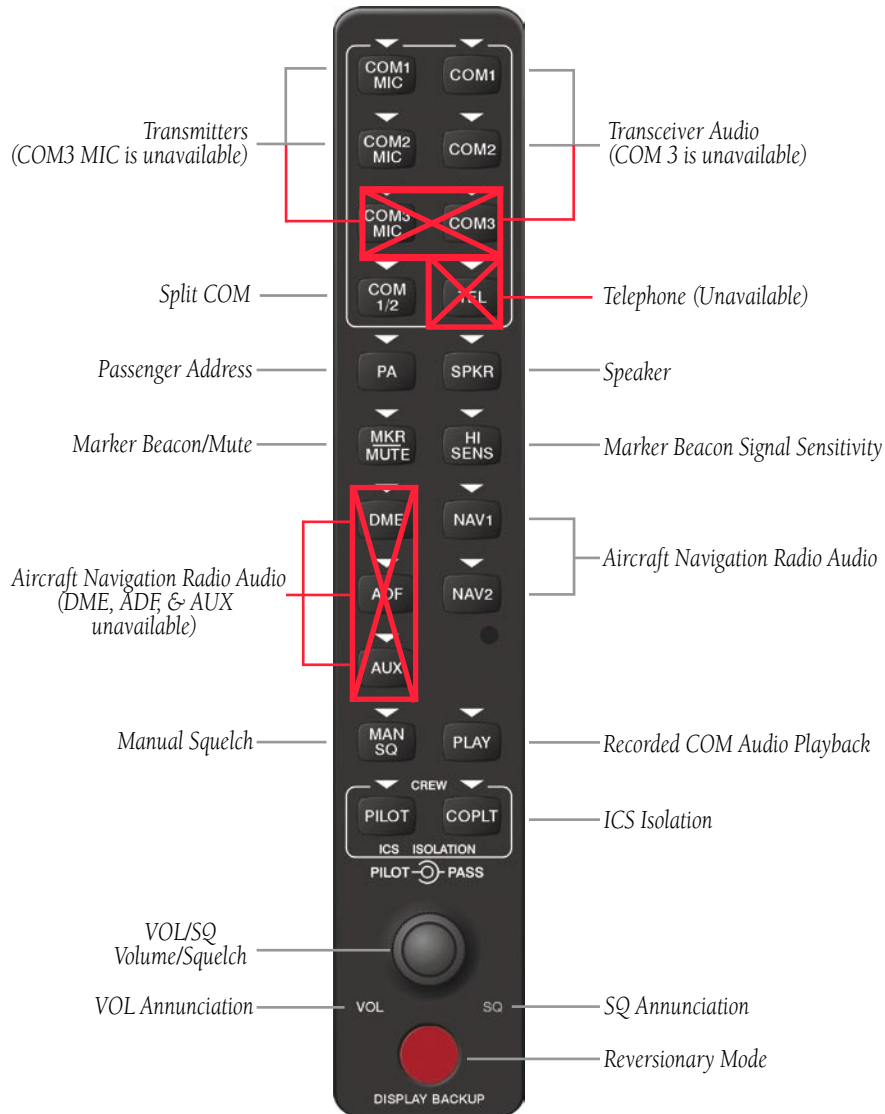

Figure 5-1 Audio Panel Controls

5.1 COM RADIO SELECTION

Pressing the **COM1 MIC** or **COM2 MIC** Key selects the active transmitter (i.e., microphone). The associated receiver audio (**COM1** or **COM2**) also becomes selected when the COM MIC key is pressed.

To prevent deselecting the desired received audio when pressing another COM MIC key, press the already selected **COM1** or **COM2** Key before pressing the other COM MIC key.



Figure 5-2 Transceivers

5.2 SPLIT COM FUNCTION



NOTE: Split COM performance is affected by the distance between the antennas and the separation of the tuned frequencies.



Figure 5-3 Split COM Function

Pressing the **COM 1/2** Key selects and deselects the split COM function. During split COM operation, the **COM1**, **COM1 MIC**, **COM2**, and **COM2 MIC** Keys are active.

When the **COM 1/2** Key is selected, COM1 is used by the pilot for transmission and COM2 is used by the copilot. The **COM1 MIC** annunciator blinks when the pilot's Push-to-talk is pressed and the **COM2 MIC** annunciator blinks when the copilot's Push-to-talk is pressed.

In this mode, both the pilot and the copilot can transmit simultaneously over separate radios. The pilot can still monitor NAV1, NAV2, and MKR audio as selected, but the copilot is only able to monitor COM2.

5.3 MARKER BEACON RECEIVER

The marker beacon receiver is always on. Only the marker beacon audio can be turned off. Figure 5-4 shows the marker beacon annunciators on the PFD.

When the **MKR/MUTE** Key is pressed, the key annunciator is lit and the audio tone can be heard over the speaker or headsets during marker beacon reception.

When the tone is active, pressing the **MKR/MUTE** Key once mutes the audio but does not affect the marker annunciator. The audio returns when the next marker signal is received.

To turn off the marker beacon audio, press the **MKR/MUTE** Key once when there is no marker indication present, or press twice when an indication is present. The key annunciator will be extinguished when the marker beacon audio is turned off.

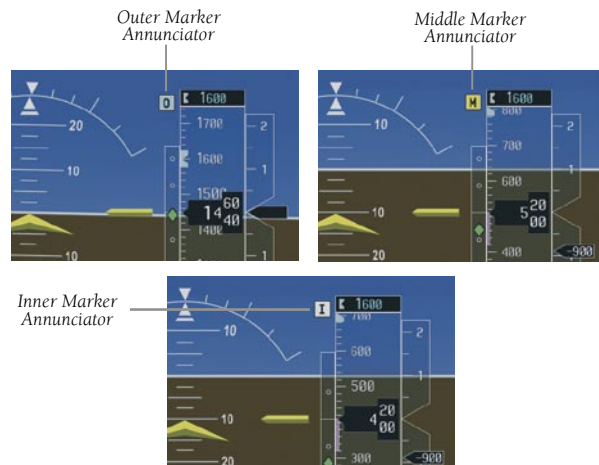

Figure 5-4 Marker Beacon Annunciators on the PFD

Marker Beacon Signal Sensitivity

The **HI SENS** Key can be pressed for increased marker beacon signal sensitivity.



Figure 5-5 Marker Beacon

5.4 NAV RADIO AUDIO SELECTION

Pressing **NAV1** or **NAV2** selects and deselects the radio source and activates the annunciator. Selected audio can be heard over the headset and the speakers. These two keys can be selected individually or together.



Figure 5-6 Navigation Radios

5.5 INTERCOM SYSTEM (ICS) ISOLATION

Press the **PILOT** and/or **COPLT** Key to select who is isolated from hearing the NAV/COM radios and music. Selection scenarios are addressed in Table 5-1.



Figure 5-7 ICS Isolation

Mode	PILOT KEY ANNUNCIATOR	COPLT KEY ANNUNCIATOR	Pilot Hears	Copilot Hears	Passenger Hears
ALL	OFF	OFF	Selected radios; pilot; copilot; passengers; MUSIC 1	Selected radios; pilot; copilot; passengers; MUSIC 1	Selected radios; pilot; copilot; passengers; MUSIC 2
PILOT	ON	OFF	Selected radios; pilot	Copilot; passengers; MUSIC 1	Copilot; passengers; MUSIC 2
COPILOT	OFF	ON	Selected radios; pilot; passengers; MUSIC 1	Copilot	Selected radios; pilot; passengers; MUSIC 2
CREW	ON	ON	Selected radios; pilot; copilot	Selected radios; pilot; copilot	Passengers; MUSIC 2

Table 5-1 ICS Isolation Modes

5.6 INTERCOM SQUELCH CONTROL

Select manual squelch for intercom audio by pressing the **MAN SQ** Key to light the annunciator.

Pressing the small **VOL/SQ** Knob now switches between volume and squelch adjustment by lighting **VOL** or **SQ** respectively.



Figure 5-8 Volume/Squelch Control

5.7 DIGITAL CLEARANCE RECORDER AND PLAYER

Each reception of primary active COM audio is automatically recorded in a memory block. When the next transmission is received, it is recorded in the next memory block, and so on. Once the 2.5 minutes of recording time has been reached, the recorder begins recording over the stored memory blocks, starting from the oldest block. Powering off the unit automatically clears all recorded blocks.



Figure 5-9 Playback

- Pressing **MKR/MUTE** while playing a memory block stops play.
- Pressing the **PLAY** Key during play begins playing the previously recorded memory block. Each subsequent press of the **PLAY** Key will begin playing the next previously recorded block.

If a COM input signal is detected while playing, play is halted and the new COM input signal is recorded as the latest block.

- Pressing **PLAY** once plays the latest recorded memory block, then returns to normal operation.

SECTION 6: AUTOMATIC FLIGHT CONTROL

In addition to the AFCS (Automatic Flight Control System) keys on the MFD, as discussed in the System Overview section, the following buttons and switches used by the AFCS are located in the cockpit separately from the PFD and MFD.

- **AP DISC (Autopilot Disconnect) Button** — Located on the pilot's control stick, pressing this button disengages the autopilot. Pressing it also acknowledges an autopilot disconnect.
- **CWS (Control Wheel Steering) Button** — Located on the pilot's control stick, pressing and holding the **CWS** button disengages the control surface servos without disengaging the autopilot. If the flight director has not been activated, pressing the **CWS** button will activate the flight director in the default pitch and roll hold modes.
- **GO AROUND Button** — Located on the instrument panel, the **Go Around** Button disengages the autopilot and selects the Go Around (wings level) mode.
- **MET (Manual Electric Trim) Switch** — This switch is used to operate manual electric pitch trim. Moving the switch forward trims the aircraft nose down. Moving the switch aft trims the aircraft nose up.

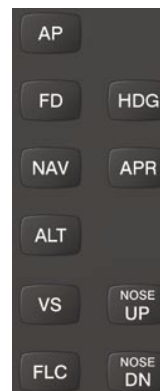

Figure 6-1 AFCS Keys

Pressing the **FD** Key activates only the flight director in the default Pitch Hold/Roll modes without engaging the autopilot. Pressing the **AP** Key activates the flight director, and engages the autopilot. When only the flight director is engaged, pressing the **FD** Key disengages the flight director.

Upon activation of the autopilot and/or flight director, command bars are displayed on the PFD. If the attitude information being sent to the flight director becomes invalid or unavailable, the command bars are removed from the display.



Figure 6-2 Command Bars

6.1 MODE ANNUNCIATIONS

Mode annunciations are displayed on the PFD. Figure 6-3 shows the AFCS Status Box fields. Modes associated with aircraft movement about the roll axis are displayed on the left side. Modes associated with aircraft movement about the pitch axis are displayed on the right. Armed modes are displayed in white and active modes are displayed in green.

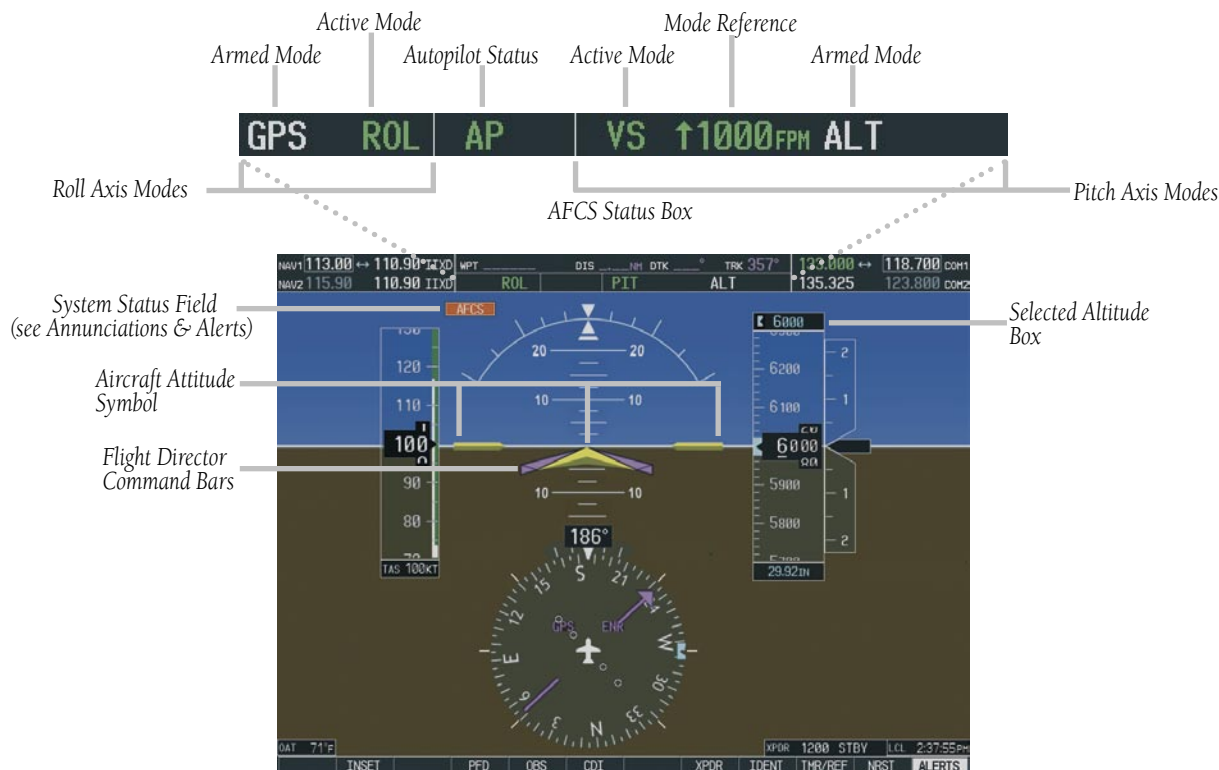

Figure 6-3 PFD AFCS Display

6.2 OVERSPEED PROTECTION

An overspeed annunciation (flashing inverse video) is displayed above the airspeed tape.



Figure 6-4 Overspeed Annunciation

When an overspeed caution occurs, reduce engine power and/or adjust the pitch reference to slow the aircraft.

6.3 AP ENGAGEMENT/DISENGAGEMENT

When the **AP** Key is pressed, the system engages the autopilot. If the flight director is not already active, it is also engaged when the **AP** Key is pressed.

Autopilot engagement is displayed in the Autopilot Status field of the AFCS Status Box. Autopilot engagement is indicated by a green 'AP'.



Figure 6-5 Autopilot Engaged Annunciation

Automatic Disengagement

Automatic disengagement typically occurs due to a failure. Automatic disengagement is annunciated by a flashing ‘AP’, alternating red on white and white on red in the Autopilot Status field. Also, the autopilot disconnect aural alert will be heard. Both the annunciation and the aural alert will continue until acknowledged by pressing the **AP DISC** button or the **MET** switch.



Figure 6-6 Automatic Disconnect Annunciation

Manual Disengagement

The autopilot may also be manually disengaged by pressing the **AP DISC** button, the **GO AROUND** button, or by pressing the **AP** Key on the MFD. Manual disengagement is annunciated by a five-second flashing yellow ‘AP’ in the Autopilot Status field and by a two-second Autopilot disconnect aural alert.



Figure 6-7 Manual Disconnect Annunciation

Control Wheel Steering

Pressing and holding the **CWS** button disengages the servos from the flight control surfaces and allows manual maneuvering of the aircraft. At the same time, the flight director is synchronized to the aircraft attitude during the maneuver. The ‘AP’ annunciation is temporarily replaced by ‘CWS’ in white until the **CWS** button is released.



Figure 6-8 CWS Annunciation

6.4 LOSS OF DATA

In general, a flashing yellow mode annunciation indicates either the loss of sensor data (AHRS, ADC, or GIA) or loss of navigation data (VOR, LOC, or GPS) required to compute commands.

When such a loss occurs, the system automatically reverts to the default mode for the affected axis (wings level ROL for roll axis, PIT for pitch axis). The flashing annunciation stops when the pilot presses the affected mode button or selects another mode for the axis. If no pilot action is taken, the flashing annunciation stops after ten seconds.

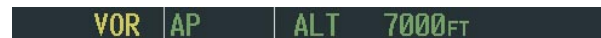

Figure 6-9 Loss of VOR Signal

6.5 PITCH AXIS MODES

Mode annunciations for active pitch axis modes are shown in green during normal operation. Note the Go-Around button is not located on the MFD.

AFCS Key	AFCS Mode	Annunciation
FD/AP only	Pitch Hold (Default)	PIT
ALT	Altitude Hold	ALT nnnnn FT
VS	Vertical Speed	VS nnnn FPM
FLC	Flight Level Change	FLC nnn KT
APR	Glideslope (vertical component of Approach)	GS
GO AROUND	Go Around	GA

The default pitch axis mode is Pitch Hold (PIT). When no other pitch axis modes are selected, this is the active pitch axis mode when the autopilot and/or flight director is engaged.

Pitch Hold Mode (PIT)

- 1) Press the **AP** or **FD** Key. 'PIT' will be displayed in green in the Active Mode field of the AFCS Status Box. The system will maintain or give command bar direction for a constant pitch attitude (pitch reference) depending on which key is pressed.

selected altitude is reached 'ALT' will flash in green for 10 seconds in the Active Mode field, after which the annunciation stops flashing. This signals the altitude capture is complete and the selected altitude will be maintained.



Figure 6-10 Pitch Hold Mode

- 2) Altitude Hold mode is automatically armed with 'ALT' displayed white in the Armed Mode field to the right of the 'PIT' annunciation.
- 3) Pitch attitude can be adjusted in 0.5 degree increments by pressing the **NOSE UP/NOSE DN** Keys.
- 4) Aircraft pitch may also be changed by pressing and holding the **CWS** button to manually establish the desired pitch using the control stick. When the **CWS** button is released, the current pitch angle will be maintained.
- 5) If desired, enter an altitude in the Selected Altitude Box by turning the **ALT** Knob. As the

If only the flight director is engaged, pitch commands are given to manually maintain the selected altitude.

Altitude Hold Mode (ALT)

- 1) Press the **ALT** Key. The flight director is activated (if not already active) and 'ALT' is now displayed in green in the Active Mode field with the current altitude displayed in the Altitude Reference field.
- 2) Pitch commands will be given to manually maintain the current altitude. Press the **AP** Key to engage the autopilot for maintaining the current altitude.



NOTE: If the Selected Altitude is captured during CWS maneuvering, the Flight Director altitude reference is not changed. To adjust the altitude reference in this case, the pilot must again press the **CWS** button after the Selected Altitude is captured.

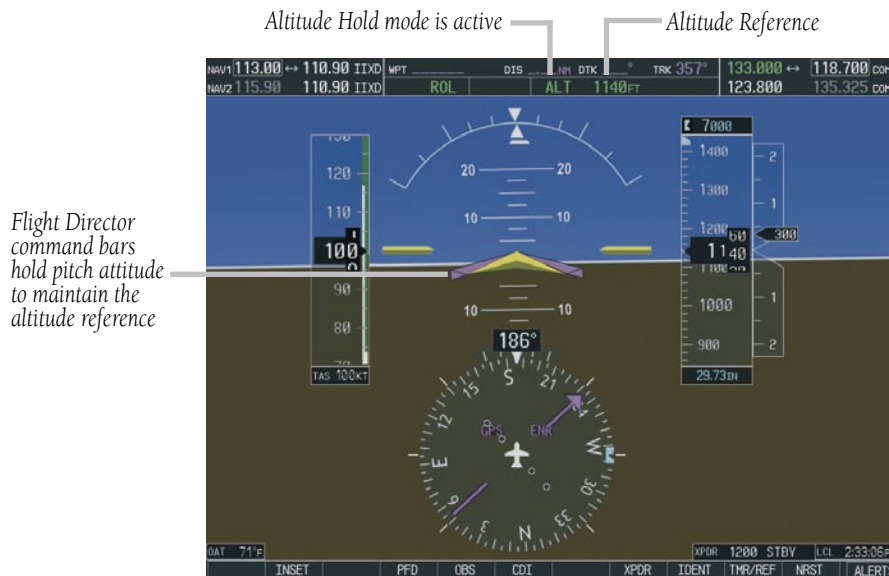

Figure 6-11 Altitude Hold Mode

- 3) To change aircraft altitude, press and hold the **CWS** button and manually maneuver to the desired altitude. Upon reaching the desired altitude, release the **CWS** button. This new altitude is now displayed in the Altitude Reference field. The autopilot will now hold the aircraft at this altitude.

Vertical Speed Mode (VS)

- 1) Press the **VS** Key. The flight director is now activated (if not already active) and 'VS' is displayed in green in the Active Mode field and the Vertical Speed Bug will appear on the Vertical Speed Indicator. Pitch commands are given to manually maintain vertical speed. Press the **AP** Key to engage the autopilot for maintaining the current vertical speed.

Altitude Hold mode is automatically armed with 'ALT' displayed white in the Armed Mode field to the right of the 'VS' annunciation.

- 2) The Vertical Speed Bug can be adjusted in 100 fpm increments by pressing the **NOSE UP/NOSE DN** Keys to set the desired vertical speed. The vertical speed setting will be displayed in the Selected Vertical Speed Box and in the Vertical Speed Reference field in the AFCS Status Box.

The Vertical Speed Box is located above the VSI when the aircraft is climbing and below the VSI when descending.

- 3) Vertical speed may also be changed by pressing and holding the **CWS** button to manually establish the desired vertical speed using the control stick. When the **CWS** button is released, the current vertical speed will be maintained.
- 4) A desired altitude may be entered in the Selected Altitude Box by turning the **ALT** Knob. With Altitude Hold mode armed, as the selected altitude is reached 'ALT' will flash in green for 10 seconds in the Active Mode field, after which the annunciation stops flashing. This signals the altitude capture is complete and the selected altitude will be maintained. If only the flight director is engaged, pitch commands are given to manually maintain the selected altitude.

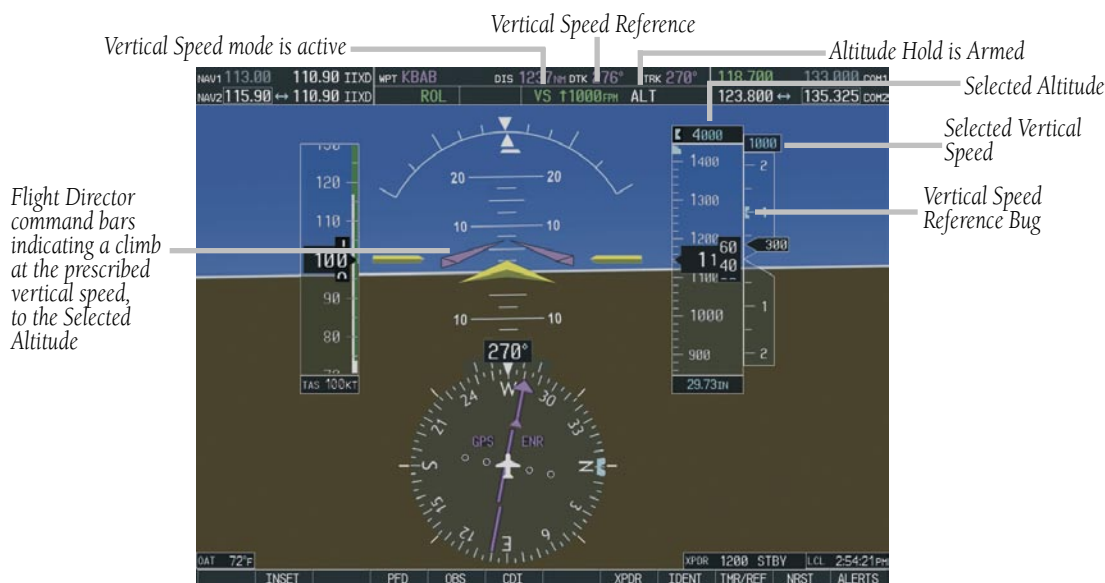

Figure 6-12 Vertical Speed Hold Mode

Flight Level Change Mode (FLC)

- 1) Select the desired altitude by turning the **ALT** Knob to set the altitude in the Altitude Select Box. This altitude must be selected first because Flight Level Change mode will only fly **toward** a selected altitude.
- 2) Press the **FLC** Key. The flight director is activated (if not already active) and 'FLC' is now displayed in green in the Active Mode field and the Airspeed Bug will appear on the Airspeed Indicator. Pitch commands are given to manually maintain airspeed. Press the **AP** Key to engage the autopilot for maintaining the current airspeed.

Altitude Hold mode is automatically armed with 'ALT' displayed white in the Armed Mode field to the right of the 'FLC' annunciation.

- 3) The Airspeed Bug can be adjusted in 1 knot increments by pressing the **NOSE UP/NOSE DN** Keys to set the desired airspeed. The airspeed setting will be displayed in the Selected

Airspeed Box above the Airspeed Indicator and in the Airspeed Reference field in the AFCS Status Box.

- 4) Airspeed may also be changed by pressing and holding the **CWS** button to manually establish the desired airspeed using the control wheel. When the **CWS** button is released, the current airspeed will be maintained.
- 5) Adjust engine power to allow the autopilot to fly the aircraft at a pitch attitude which corresponds to the selected airspeed and the desired flight profile (descent or climb).
- 6) With Altitude Hold mode armed, as the selected altitude is reached, 'ALT' will flash in green for 10 seconds in the Active Mode field, after which the annunciation stops flashing. This signals the altitude capture is complete and the selected altitude will be maintained at the selected airspeed. If only the flight director is engaged, pitch commands are given to manually maintain the selected altitude.



Figure 6-13 Flight Level Change Mode

Go-Around Mode (GA)

Pressing the **GO AROUND** button (not located on the MFD) engages the flight director in a wings level, 7 degree pitch up attitude. Go-Around mode disengages the autopilot, and arms Altitude Hold Mode automatically. Subsequent autopilot engagement is also allowed. If the pitch attitude is changed manually (e.g with the **CWS** button or the **NOSE UP/NOSE DN** Keys), Pitch and Roll Hold modes will automatically be selected.

Glideslope (GS)



NOTE: Pressing the CWS button while Glideslope Mode is active does not cancel the mode. The autopilot guides the aircraft back to the glideslope upon release of the CWS button.

Glideslope Mode is only available when the flight director has been set for approach. Glideslope Mode is automatically armed under the following conditions:

- Valid localizer frequency is tuned
- Horizontal Situation Indicator (HSI) is in LOC mode, with valid deviation indication
- Valid glideslope deviation
- **APR** Key is pressed



6.6 ROLL AXIS MODES

Mode annunciations for active roll axis modes are shown in green during normal operation.

AFCS Key	AFCS Mode	Annunciation
FD/AP only	Roll Hold (Default)	ROL
HDG	Heading Select	HDG
NAV	VOR Enroute Arm / Capture / Track	VOR
	GPS Arm / Capture / Track	GPS
	BC Arm / Capture / Track	BC
	LOC Arm / Capture / Track; (No Glideslope)	LOC
APR	GPS Arm / Capture / Track	GPS
	VOR Approach Arm / Capture / Track	VAPP
	ILS Approach Arm / Capture / Track (Glideslope pitch mode automatically armed)	LOC
GO AROUND	Go Around (Wings Level)	GA

The default roll axis mode is Roll Hold (ROL). When no other roll axis modes are selected, this is the active roll axis mode when the autopilot and/or flight director is engaged.

Roll Hold Mode (ROL)

- 1) Press the **FD** or **AP** Key.

If the aircraft bank angle is ≥ 6 degrees when the key is pressed, Roll Hold mode is selected by default. Roll attitude at the time of activation is maintained by the autopilot up to 22° . If

only the flight director is active, command bars indicate the proper roll attitude.

If the aircraft bank angle is < 6 degrees when the key is pressed, the aircraft will be maintained at wings level. If only the flight director is active, command bars give guidance to maintain wings level.

Roll Hold mode is annunciated by 'ROL'.

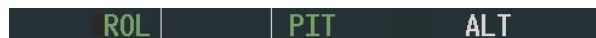

Figure 6-15 Roll Hold Mode

- 2) A new heading can be established by pressing and holding the **CWS** button and manually turning the aircraft to the desired new heading. Release the **CWS** button and the aircraft will maintain wings level at approximately the new heading, but will not hold the heading. The same practice applies to holding roll attitude.

Heading Select Mode (HDG)

- 1) Turn the **HDG** Knob to move the heading bug on the HSI to the desired heading. When the knob is turned, the Selected Heading Box will appear and remain for three seconds after the knob stops moving. The selected heading will be displayed in the Selected Heading Box.
- 2) With the autopilot and/or flight director engaged, press the **HDG** Key. 'HDG' is now displayed in green in the Active Mode field. If the autopilot is engaged, the aircraft will begin to turn toward the selected heading. When the selected heading is reached, the aircraft will maintain this heading. If only the flight director is engaged, manually maneuver the aircraft to the command bars to acquire the selected heading.
- 3) The heading may be adjusted by turning the **HDG** Knob and moving the heading bug to a new heading. The aircraft will turn in the same direction the heading bug is moved. However, if the heading bug is moved more than 340 degrees at a time, a turn reversal will be the result.



Figure 6-16 Heading Select Mode

Navigation Mode (GPS, VOR, LOC, or BC)

Pressing the **NAV** Key activates the Navigation Mode. The Navigation mode acquires and tracks the selected navigation receiver on the HSI (e.g. GPS, VOR or LOC). GPS roll steering commands are followed when the HSI is in GPS mode, and creates roll steering commands from the Selected Course and deviation when the HSI is in VOR, LOC, or BC (backcourse) modes.

Turning the **CRS** Knob moves the Course Pointer and displays the Selected Course Box. The Selected Course is displayed in the box. The box is displayed while the knob is turning and disappears three seconds after the knob stops turning.

Backcourse mode is automatically selected when the localizer front course is greater than 105 degrees from the aircraft heading.

Navigation Mode Armed

If the CDI is not centered (deviation >1 dot) when the Navigation mode is selected, the mode is automatically armed. The armed annunciation appears in white to the left of the active roll axis mode.

See the Example Procedures Using AFCS section for more information.



NOTE: When intercepting a flight plan leg, the Flight Director will give commands to capture the active leg at approximately a 45 degree angle to the track between the waypoints defining the active leg. The Flight Director will not give commands fly to the starting waypoint of the active leg.



NOTE: When making a backcourse approach, set Selected Course to the localizer front course.

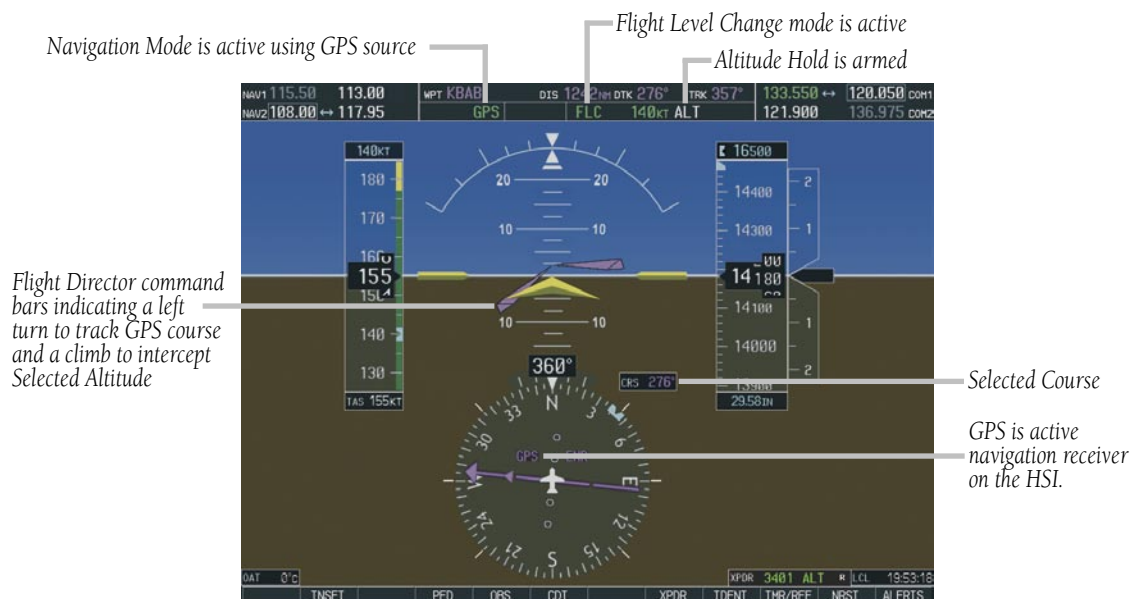

Figure 6-17 Navigation Mode

Approach Mode (GPS, VAPP or LOC)

The Approach mode acquires and tracks the selected navigation receiver on the HSI (GPS, VOR or LOC). This mode uses the selected navigation receiver deviation and desired course inputs to fly the approach. The Approach mode provides greater sensitivity for VOR tracking than Navigation mode, and allows the autopilot to fly an ILS approach with a glideslope.



NOTE: While using Approach mode, the Glideslope mode is automatically armed when LOC mode is selected on the HSI.

If the CDI is is not centered (deviation >1 dot) when the Approach mode is selected, the mode is automatically armed. The armed annunciation appears in white to the left of the active roll axis mode.

See the Example Procedures Using AFCS section for more information.

Go Around (GA)

Go Around mode maintains a wings level, 7 degree nose up attitude for instances where the pilot wishes to execute a missed approach or go around. Figure 6-14 depicts the Go Around mode on the PFD.



6.7 EXAMPLE PROCEDURES USING AFCS

This section provides a scenario-based set of procedures showing various autopilot modes used during a flight. Other modes and uses of the G1000 may be necessary in real-world scenarios. In this scenario, the aircraft departs Reid-Hillview Airport (KRHV) from runway 13L, enroute to Fresno Yosemite International Airport (KFAT). Climb to an altitude of 7,000 feet MSL and fly a heading of 070 degrees to intercept airway V107. Fly airway V107 to Panoche VORTAC (PXN) using VOR navigation, then fly airway V230 using a GPS flight plan. Prior to reaching Clovis VORTAC (CZQ), descend to 3,000 feet and load the ILS approach to R29R at KFAT. Fly the ILS approach and execute a missed approach.



NOTE: The diagrams in the following examples are for instructional purposes only and may not be used for navigation.

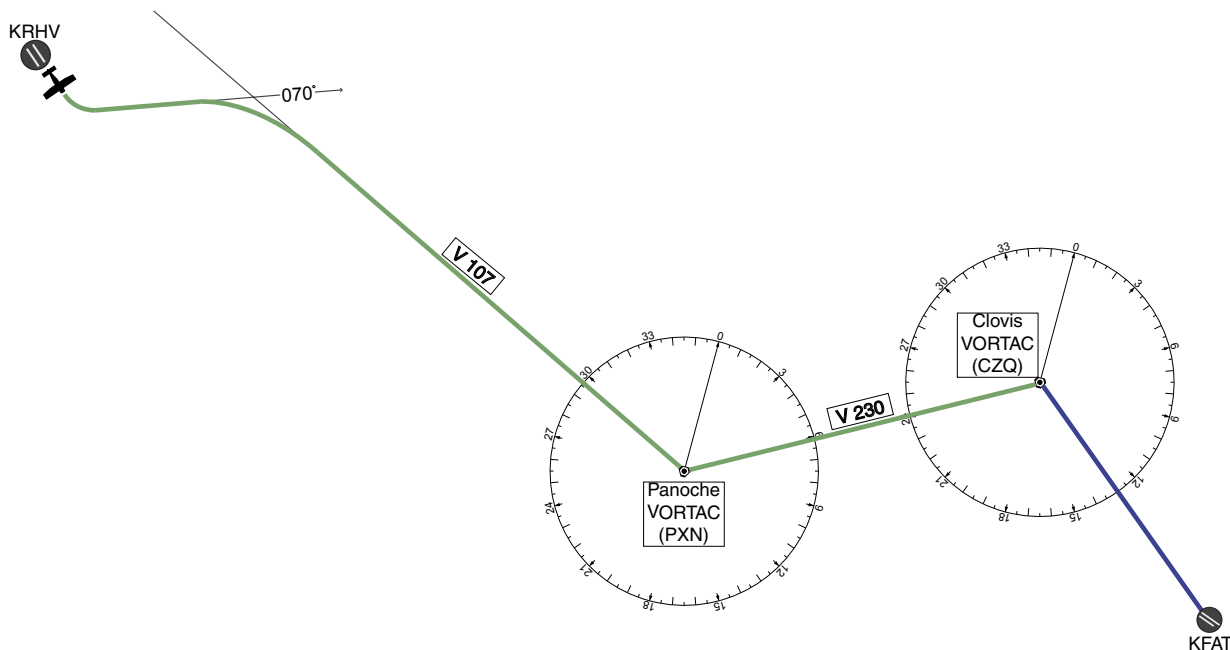

Figure 6-19 Flight Plan Overview

Departure

Climb to the selected altitude and fly an assigned heading:

- 1) Upon takeoff, set the Selected Altitude to 7000 feet using the **ALT** Knob.

To have the autopilot capture this altitude, use Pitch Hold, Vertical Speed, or Flight Level Change Mode. In this example, Vertical Speed Mode is used.

- 2) Upon reaching the desired vertical speed of 1000 fpm, enable the flight director in Vertical Speed Mode.
 - a) Press the **VS** Key. Altitude Hold Mode is armed automatically.

ROL		VS ↑1000 _{FPM}	ALT
-----	--	-------------------------	-----

- b) Press the **AP** Key to engage the autopilot in Roll Hold and Vertical Speed modes.

ROL	AP	VS ↑1000 _{FPM}	ALT
-----	----	-------------------------	-----

- 3) Activate Heading Select Mode while the autopilot is engaged in the climb.

- a) Use the **HDG** Knob to set the Selected Heading to 070°.
- b) Press the **HDG** Key. The autopilot follows the Heading Bug on the HSI and turns the aircraft to the desired heading.

HDG	AP	VS ↑1000 _{FPM}	ALT
-----	----	-------------------------	-----

- 4) As the aircraft climbs to the Selected Altitude, the flight director changes from Vertical Speed to Altitude Hold Mode. This active mode change is indicated by the green 'ALT' annunciation flashing for ten seconds.

HDG	AP	ALT 7000 _{FT}	
-----	----	------------------------	--

- 5) Upon reaching the Selected Altitude, the autopilot completes the capture process and levels the aircraft. From this point, the flight director continues to operate in Altitude Hold Mode.

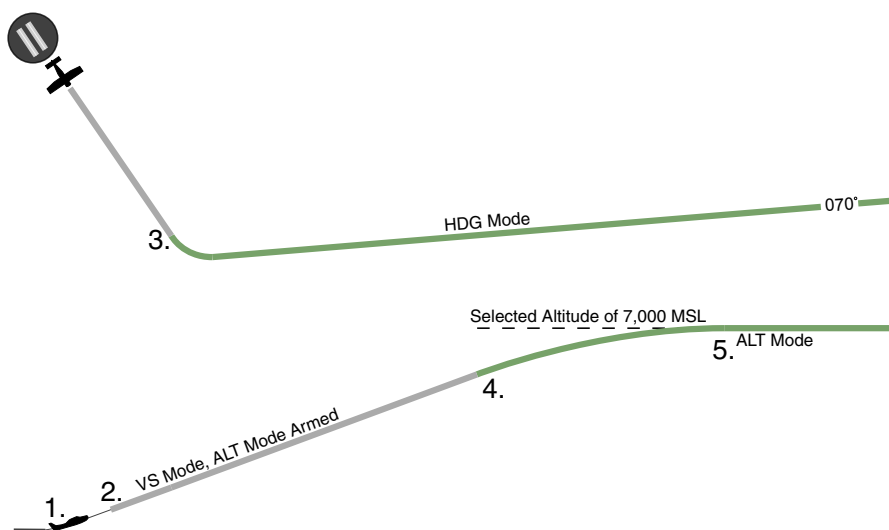

Figure 6-20 Departure

Intercepting a VOR Radial



NOTE: Changing the HSI mode cancels Navigation Mode and causes the flight director to revert to Roll Hold Mode.

During climb-out, the autopilot continues to fly the aircraft in Heading Select Mode. Airway V107 to Panoche VORTAC (PXN) should now be intercepted.

- 1) Tune the VOR frequency and activate Heading Select Mode.
 - a) Use the **CDI** Softkey to set the HSI mode to VOR.
 - b) Use the **CRS** Knob to set the Selected Course to 116°. Note that at this point, the flight director is still in Heading Select Mode and the autopilot continues to fly 070°.

- c) Press the **NAV** Key to arm Navigation Mode. The white annunciation 'VOR' appears to the left of the active roll mode.

VOR	HDG	AP	ALT	7000FT
-----	-----	----	-----	--------

- 2) When the CDI shows less than one dot, the flight director changes from Heading Select to Navigation Mode, and the green annunciation 'VOR' flashes. The autopilot begins turning to intercept the Selected Course.

VOR	AP	ALT	7000FT
-----	----	-----	--------

- 3) The autopilot continues the turn until the aircraft is established on the Selected Course.

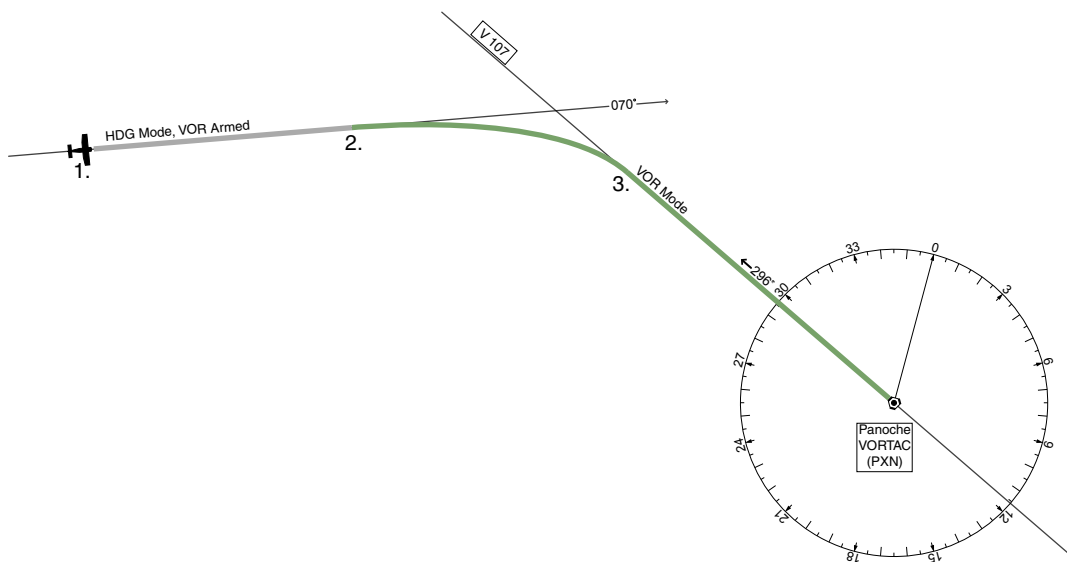

Figure 6-21 Intercepting a VOR

Flying a GPS Flight Plan

- 1) Enter Panoche VORTAC (PXN) and Clovis VORTAC (CZQ) into the GPS flight plan, in preparation to intercept this leg.
- 2) Transition from VOR to GPS Navigation Mode.
 - a) Use the **CDI** Softkey to put the HSI in GPS mode. This cancels VOR mode on the HSI and the flight director loses the VOR signal. As a result, the VOR annunciation flashes yellow.

Flashes for ten seconds, then transitions to ROL.

VOR	AP	ALT 7000FT
-----	----	------------

ROL	AP	ALT 7000FT
-----	----	------------

- b) Press the **NAV** Key to activate GPS Navigation Mode to cause the autopilot to steer the aircraft toward the active flight plan leg.

GPS	AP	ALT 7000FT
-----	----	------------

If the **NAV** Key is not pressed within 10 seconds of the HSI mode change, the flight director will roll the wings level and enter Roll Hold Mode.

- 3) Once the flight plan leg is intercepted, the autopilot continues to track GPS guidance to the end of the flight plan.

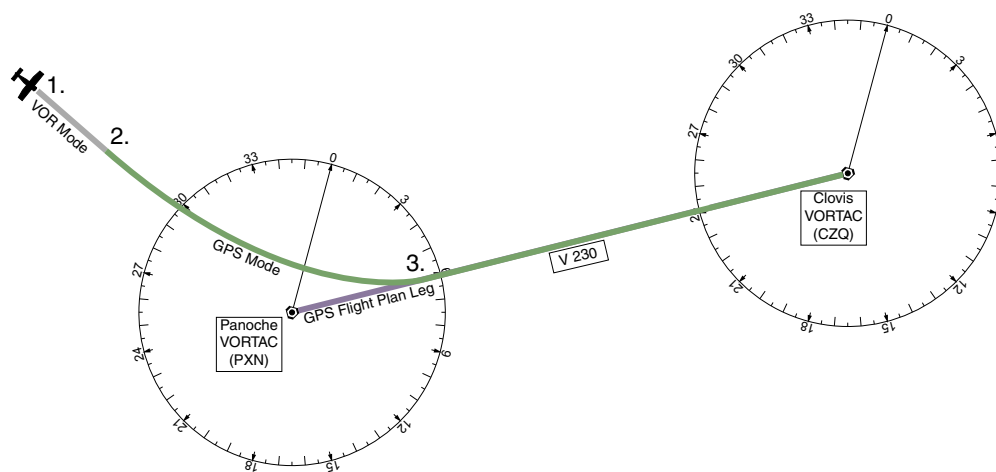

Figure 6-22 Transition to GPS Flight Plan

Flight Level Change (Descent)

While flying the GPS leg from Panoche VORTAC to Clovis VORTAC, the aircraft is cleared to make a descent to 3000 feet in preparation for the approach to KFAT.

- 1) Enter Flight Level Change Mode.
 - a) Using the **ALT** Knob, set the Selected Altitude to 3000 feet.
 - b) Press the **FLC** Key to activate Flight Level Change Mode. The annunciation 'FLC' appears next to the Airspeed Reference, which defaults to the current aircraft airspeed, 142 knots. Altitude Hold Mode is armed automatically.

- 2) Reduce power to allow descent in Flight Level Change Mode. The autopilot maintains the Airspeed Reference.
- 3) Upon capturing the Selected Altitude, the flight director changes from Flight Level Change to Altitude Hold Mode. The annunciation 'ALT' flashes in green to indicate the altitude capture. After the capture is complete, the autopilot holds the aircraft level at the Selected Altitude.

GPS	AP	ALT 3000FT
-----	----	------------

GPS	AP	FLC 142KT ALT
-----	----	---------------

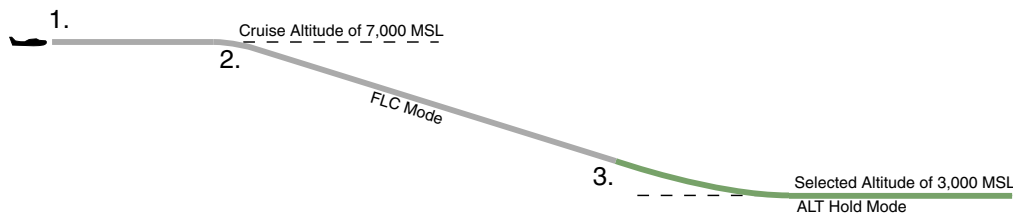

Figure 6-23 FLC Descent

ILS Approach

- 1) Transition from GPS Navigation Mode to Heading Select Mode.
 - a) Load the Runway 29R ILS approach for KFAT into the Flight Plan.
 - b) Select 'Vectors to Final' for the transition.
 - c) Set the Selected Heading after getting vectors from ATC and press the **HDG** Key. The autopilot turns the aircraft to the desired heading.
- 2) Use Heading Select Mode to comply with ATC vectors as requested.
- 3) In preparation for approach, tune the localizer frequency and select LOC mode on the HSI.
- 4) Press the **APR** Key when cleared for approach to arm the Approach Mode. 'LOC' and 'GS' appear in the armed roll and pitch mode fields, respectively.
- 5) The autopilot flies the ILS Approach. At the Decision Height, there are two options: push the **AP DISC** switch and land the aircraft, or use the **Go Around** button to execute a missed approach (refer to the following procedure).

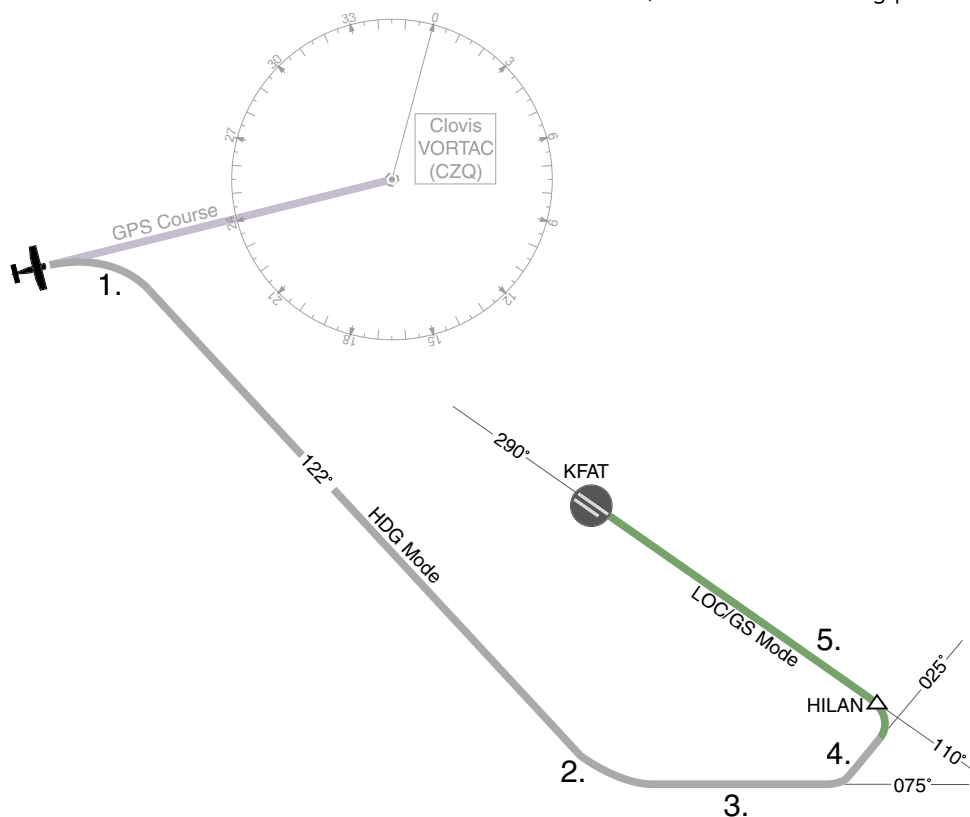

Figure 6-24 ILS Approach to KFAT

Go-Around / Missed Approach

- 1) Push the **Go Around** button at the Decision Height to execute a missed approach.

Note that when the **Go Around** button is pushed, the autopilot disconnects and the 'AP' annunciation flashes yellow for five seconds

The flight director Command Bars establish a 7 degree nose-up climb to follow.

- 2) Add power and retract flaps per the go-around procedures in the Columbia AFM. Start the climb to the prescribed altitude in the published Missed Approach Procedure.
 - a) Press the **AP** Key to re-engage the autopilot.
 - b) Press the **FLC** Key and adjust for Vx or Vy.
 - c) After reaching 400' AGL, set the HSI to HDG or GPS mode. In this example GPS mode is selected.
 - d) Select the **SUSP** Softkey to resume sequencing approach legs to the Missed Approach Hold Point (MAHP).
 - e) Press the **NAV** Key to have the autopilot fly to the MAHP. In this example, the autopilot flies direct to Clovis VORTAC according to the loaded approach (see Figure 6-25).
- 3) Use the **ALT** Knob to set a Selected Altitude to hold. The **CWS** button may be used to set a new pitch attitude.

As the Selected Altitude is captured, Altitude Hold Mode becomes active and the autopilot maintains the Selected Altitude.
- 4) Set the Selected Heading using the **HDG** Knob and press the **HDG** Key. Use the **HDG** Knob to guide the aircraft for the remainder of the hold.



NOTE: As a result of the calculations being performed by the system while flying the holding pattern, the display may resize automatically and the aircraft may not precisely track the holding pattern.

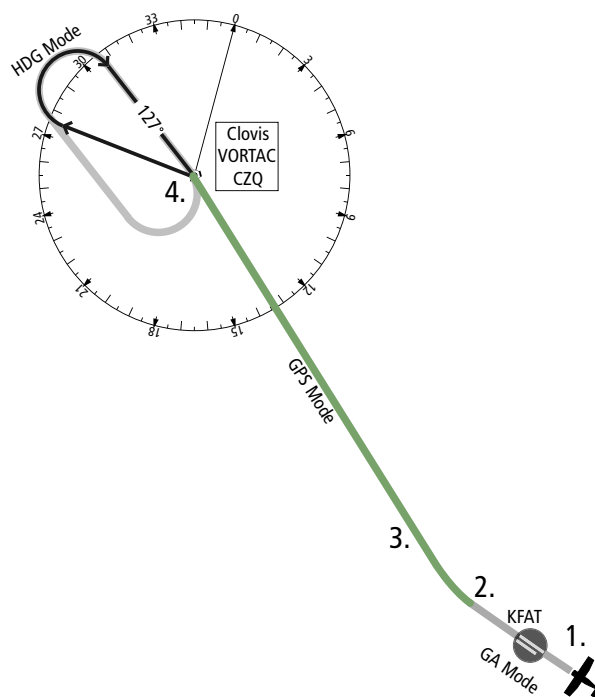

Figure 6-25 Go Around / Missed Approach

Blank Page

- 3) Turn the small **FMS** Knob to display a list of waypoints or airports.
- 4) Continue turning the small **FMS** Knob to scroll through the list and highlight the desired waypoint or airport.
- 5) Press the **ENT** Key to confirm the selection. Press **ENT** again to activate a Direct-to.

Re-center the CDI to the Destination Waypoint

Press the **Direct-to** (**D▶**) Key, followed by pressing the **ENT** Key twice. If a missed approach point (MAP) is the current destination, the approach will be canceled.

Manually Define the Direct-to Course

- 1) Press the **Direct-to** (**D▶**) Key and enter a waypoint as discussed in previous steps, or to edit the active direct-to.
- 2) Turn the large **FMS** Knob to highlight the 'COURSE' field.
- 3) Turn the **FMS** Knobs to select the desired course and press the **ENT** Key.
- 4) Press the **ENT** Key again to begin navigation using the selected destination and course.

Cancelling Direct-to Navigation

- 1) Press the **Direct-to** (**D▶**) Key.
- 2) Press the **MENU** Key to display the Direct-to options menu.
- 3) With 'Cancel Direct-To NAV' highlighted, press the **ENT** Key. If a flight plan is still active, the G1000 resumes navigating the flight plan along the closest leg.

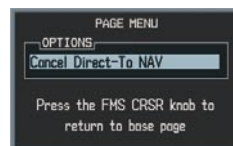

Figure 7-3 Canceling Direct-to Navigation

Direct-to Navigation from the PFD

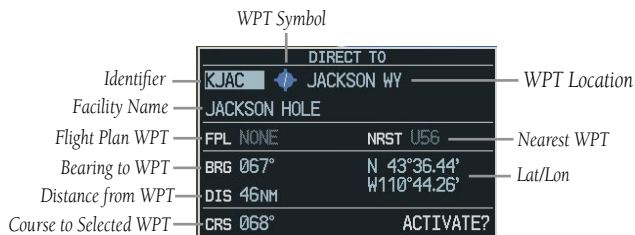

Figure 7-4 PFD Direct-to Window

- 1) Press the Direct-to Key (**D▶**).
- 2) Turn the large **FMS** Knob to place the cursor in the desired selection field.
- 3) Turn the small **FMS** Knob to begin selecting the desired identifier, location, etc.
- 4) Press the **ENT** Key.
- 5) The cursor is now flashing on 'ACTIVATE?'. Press the **ENT** Key again to activate.

Cancelling Direct-to Navigation

- 1) Press the Direct-to (**D▶**) Key.
- 2) Press the **MENU** Key to display the Options Window. The cursor will be flashing on 'Cancel Direct-to NAV'.
- 3) Press the **ENT** Key to cancel the direct-to.

7.3 AIRPORT INFORMATION

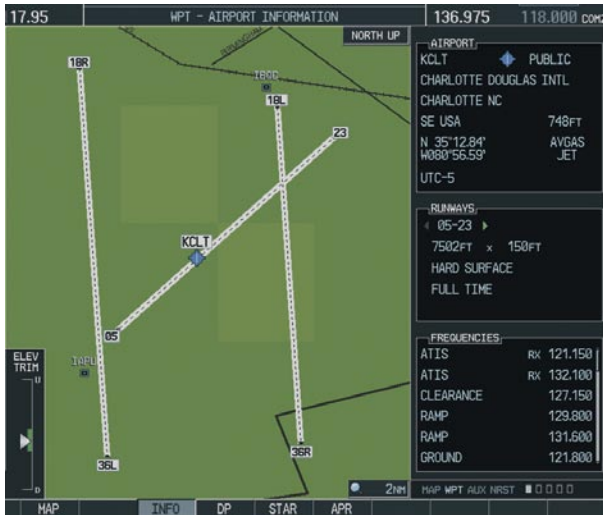

Figure 7-5 Airport Information Page

Select the Airport Information Page

- 1) Turn the large **FMS** Knob to select the 'WPT' page group.
- 2) Turn the small **FMS** Knob to select the first rectangular page icon.

Enter a Waypoint Facility Name or City Location

- 1) With the Airport Information Page displayed, press the **FMS** Knob to activate the cursor.
- 2) Turn the large **FMS** Knob to select the facility name or location (city) field.
- 3) Turn the small **FMS** Knob to select the desired first character.
- 4) Turn the large **FMS** Knob to select the next character field.
- 5) Repeat steps 3 and 4 until the facility name or location is selected, then press the **ENT** Key. If there are duplicate names in the database,

a list is displayed from which to choose the desired location.

- 6) To remove the flashing cursor, press the **FMS** Knob.

Access Runway Information

- 1) With the Airport Information Page displayed, press the **FMS** Knob to activate the cursor.
- 2) Turn the large **FMS** Knob to place the cursor on the 'RUNWAYS' identifier field.
- 3) Turn the small **FMS** Knob to display the next runway for the selected airport. Continue turning the small **FMS** Knob to select the desired runway.
- 4) To remove the flashing cursor, press the **FMS** Knob.

Access Frequency Information

- 1) With the Airport Information Page displayed, press the **FMS** Knob to activate the cursor.
- 2) Turn the large **FMS** Knob to move the cursor to the Frequencies box.
- 3) Turn either **FMS** Knob to scroll through the list, placing the cursor on the desired frequency. If a listed frequency has sector or altitude restrictions, the frequency is preceded by an info ('i') designation. Press the **ENT** Key to view the information. The following may be displayed with the frequency:
 - 'TX' – transmit only
 - 'RX' – receive only
 - 'PT' – part time frequency
- 4) Press the **ENT** Key to place the selected frequency in the standby field of the COM or NAV.
- 5) To remove the cursor, press the **FMS** Knob.

7.4 INTERSECTION INFORMATION

Select the Intersection Information Page

- 1) Turn the large **FMS** Knob to select the 'WPT' page group.
- 2) Turn the small **FMS** Knob to select the second rectangular page icon.



Figure 7-6 Intersection Information Page

Access Information on an Intersection

- 1) With the Intersection Information Page displayed, press the **FMS** Knob to activate the cursor.
- 2) Turn the **FMS** Knobs to enter a name for the identifier and press the **ENT** Key.
- 3) Press the **FMS** Knob to remove the flashing cursor.

7.5 NDB INFORMATION

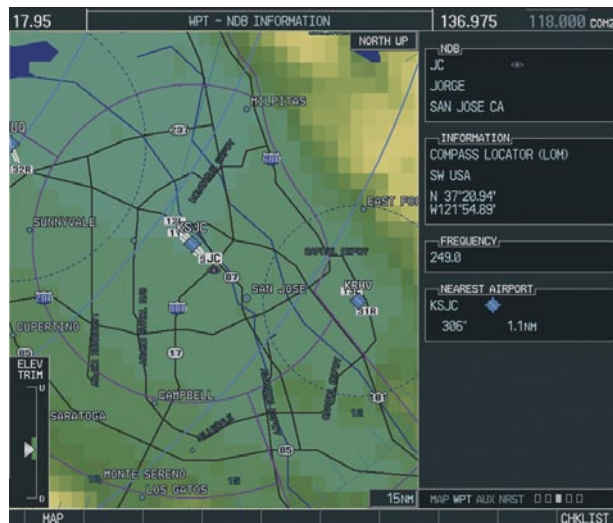

Figure 7-7 NDB Information Page

Select the NDB Information Page

- 1) Turn the large **FMS** Knob to select the 'WPT' page group.
- 2) Turn the small **FMS** Knob to select the third rectangular page icon

View Information on a Specific NDB

- 1) With the NDB Information Page displayed, press the **FMS** Knob to activate the cursor.
- 2) Turn the large **FMS** Knob to highlight the desired selection field (identifier, name or closest city).
- 3) Turn the **FMS** Knobs to enter an identifier, name or city and press the **ENT** Key.
- 4) Press the **FMS** Knob to remove the flashing cursor.

7.6 VOR INFORMATION

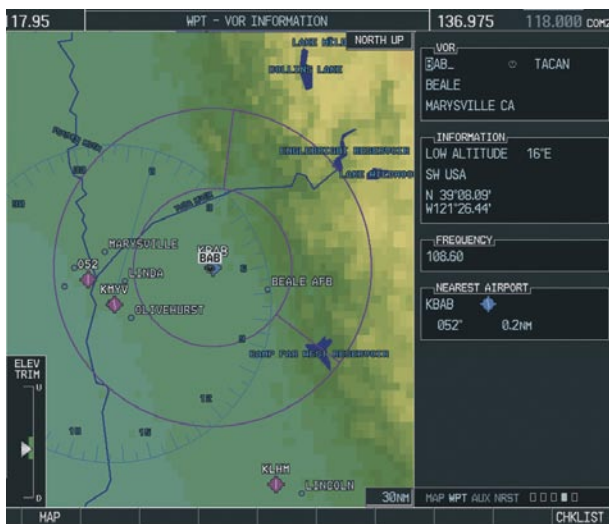

Figure 7-8 VOR Information Page

Select the VOR Information Page

- 1) Turn the large **FMS** Knob to select the 'WPT' page group.
- 2) Turn the small **FMS** Knob to select the fourth rectangular page icon.

Access Information on a VOR

- 1) With the VOR Information Page displayed, press the **FMS** Knob to activate the cursor.
- 2) Turn the large **FMS** Knob to highlight the desired selection field (identifier, name or closest city).
- 3) Turn the **FMS** Knobs to enter an identifier, name or city and press the **ENT** Key.
- 4) The 'FREQUENCY' field is now highlighted. If desired, press the **ENT** Key to place the frequency in the NAV receiver standby field.



NOTE: The numeric keypad is functional in the frequency field, but is not intended to be used to change the frequency value. Highlighting the frequency field is only intended for NAV tuning.

- 5) Press the **FMS** Knob to remove the flashing cursor.

7.7 USER WAYPOINT INFORMATION PAGE

See the Flight Planning section for a discussion on creating and modifying user defined waypoints.

7.8 NEAREST AIRPORTS



Figure 7-9 Nearest Airports Page

Nearest Airport Information on the MFD

Select the Nearest Airports Page

- 1) Turn the large **FMS** Knob to select the 'NRST' page group.
- 2) Turn the small **FMS** Knob to select the first rectangular page icon.

Access Information on a Specific Airport

- 1) With the Nearest Airports Page displayed, select the **APT** Softkey to place the cursor in the 'NEAREST AIRPORTS' field. The first airport in the nearest airports list is highlighted.
- 2) Press the **FMS** Knob, then turn the large **FMS** Knob to highlight the desired airport.
- 3) Press the **FMS** Knob to remove the flashing cursor.

Access Runway Information for the Selected Airport

- 1) With the Nearest Airports Page displayed, select the **RNWX** Softkey to place the cursor in the 'RUNWAYS' field.
- 2) Turn the small **FMS** Knob to select the desired runway.
- 3) Press the **FMS** Knob to remove the flashing cursor.

Quickly Tune the COM Transceiver to a Nearby Airport Frequency

- 1) With the Nearest Airports Page displayed, select the **FREQ** Softkey to place the cursor in the 'FREQUENCIES' field.
- 2) Turn either **FMS** Knob to select the desired frequency.
- 3) Press the **ENT** Key. The selected frequency is placed in the COM standby frequency field.
- 4) Press the **Frequency Transfer** Key to place the frequency in the active field.
- 5) Press the **FMS** Knob to remove the flashing cursor.

Nearest Airports Information on the PFD

Identifier	Bearing TO	Distance	Runway Length
U56	325°	9.3NM	3500FT
MULTICOM	122.900	RNWX	3500FT
KIDA	261°	9.5NM	ILS
TOWER	118.500	RNWX	9001FT
KRXE	352°	20.1NM	VOR
UNICOM	122.800	RNWX	4200FT

Figure 7-10 Nearest Airports Window

Select the **NRST** Softkey to display the PFD Nearest Airports Window.

View Information on a Specific Airport in the List

- 1) With the Nearest Airports Window displayed, turn either **FMS** Knob to place the cursor on the desired airport identifier.
- 2) Press the **ENT** Key to display airport information.
- 3) Press the **ENT** Key again (cursor is on 'BACK') to return to the list.

Load an Airport COM Frequency into the Active COM

- 1) With the Nearest Airports Window displayed, turn either **FMS** Knob to place the cursor on the desired airport frequency shown in the window.
- 2) Press the **ENT** Key and the selected frequency will be placed in the COM standby frequency field.
- 3) Press the **Frequency Transfer** Key to make the frequency the active frequency.

7.9 NEAREST INTERSECTIONS



Figure 7-11 Nearest Intersections Page

7.10 NEAREST NDB

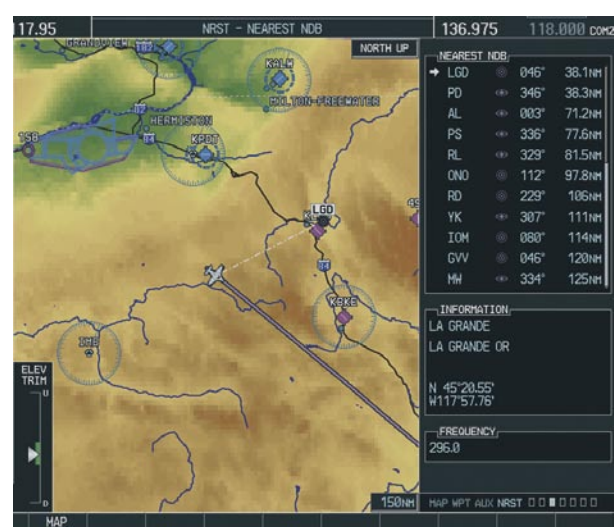

Figure 7-12 Nearest NDB Page

Select the Nearest Intersections Page

- 1) Turn the large **FMS** Knob to select the 'NRST' page group.
- 2) Turn the small **FMS** Knob to select the second rectangular page icon.

View Information on the Nearest Intersection

- 1) With the Nearest Intersections Page displayed, press the **FMS** Knob to activate the cursor.
- 2) Turn either **FMS** Knob to select the desired intersection.
- 3) Press the **FMS** Knob to remove the flashing cursor.

Select the Nearest NDB Page

- 1) Turn the large **FMS** Knob to select the 'NRST' page group.
- 2) Turn the small **FMS** Knob to select the third rectangular page icon.

Access Information on a Specific NDB

- 1) With the Nearest NDB Page displayed, press the **FMS** Knob to activate the cursor.
- 2) Turn either **FMS** Knob to select the desired NDB. The remaining information on the Nearest NDB Page pertains to the selected NDB.
- 3) Press the **FMS** Knob to remove the flashing cursor.

7.11 NEAREST VOR

Select the Nearest VOR Page

- 1) Turn the large **FMS** Knob to select the 'NRST' page group.
- 2) Turn the small **FMS** Knob to select the fourth rectangular page icon.

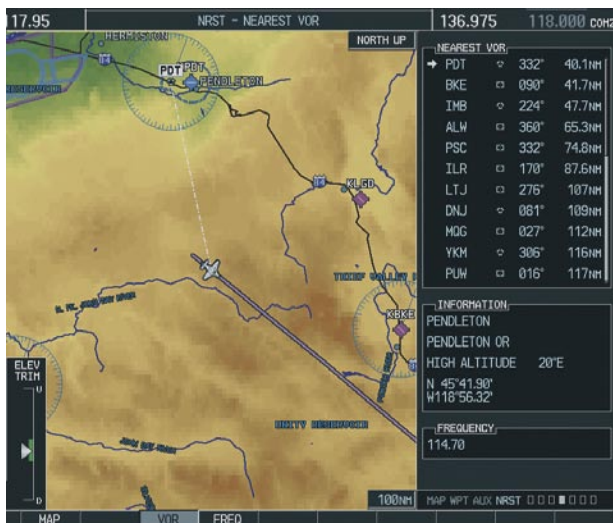

Figure 7-13 Nearest VOR Page

View Information on the Nearest VOR

- 1) With the Nearest VOR Page displayed, select the **VOR** Softkey to place the cursor in the 'NEAREST VOR' box.
- 2) Turn either **FMS** Knob to select a VOR.
- 3) Press the **FMS** Knob to remove the flashing cursor.

Select and Load a VOR Frequency

- 1) With the Nearest VOR Page displayed, select the **FREQ** Softkey to highlight the VOR frequency in the 'FREQUENCY' field.



NOTE: The numeric keypad is functional in the frequency field, but is not intended to be used to change the frequency value. Highlighting the frequency field is only intended for NAV tuning.

- 2) Press the **ENT** Key. The selected VOR frequency is placed in the NAV standby frequency field.
- 3) Press the **FMS** Knob to remove the flashing cursor.

7.12 NEAREST USER WAYPOINT



Figure 7-14 Nearest User Waypoints Page

Select the Nearest User Waypoint Page

- 1) Turn the large **FMS** Knob to select the 'NRST' page group.
- 2) Turn the small **FMS** Knob to select the fifth rectangular page icon.

Select a Nearest User Waypoint

- 1) With the Nearest User Waypoint Page displayed, press the **FMS** Knob to activate the cursor. If any previously entered User Waypoints are

within 200 nm, these will be displayed with the closest listed first.

- 2) Turn either **FMS** Knob to select the desired waypoint. The remaining information on the Nearest User Waypoint Page pertains to the selected Nearest User Waypoint.
- 3) Press the **FMS** Knob to remove the flashing cursor.

7.13 NEAREST FREQUENCIES

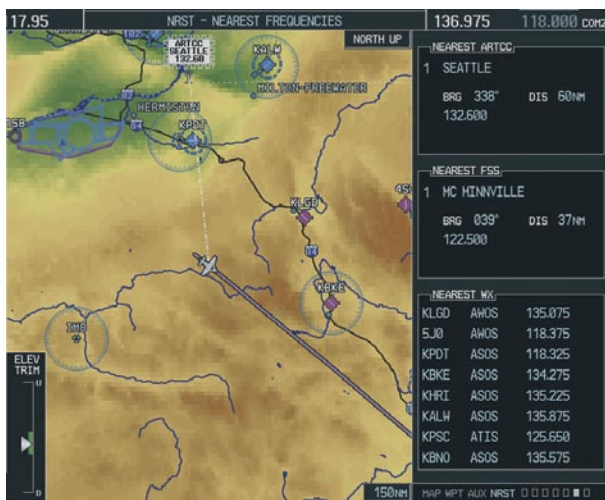

Figure 7-15 Nearest Frequencies Page

Select the Nearest Frequencies Page

- 1) Turn the large **FMS** Knob to select the 'NRST' page group.
- 2) Turn the small **FMS** Knob to select the sixth rectangular page icon.

Select and Load the Nearest ARTCC, FSS, or Weather Frequency

- 1) With the Nearest Frequencies Page displayed, select the **ARTCC**, **FSS**, or **Wx** Softkey to place the cursor in the appropriate field.

- 2) Turn the **FMS** Knobs to select the desired facility or frequency.
- 3) Press the **ENT** Key to load the frequency into the COM frequency standby field.
- 4) Press the **FMS** Knob to remove the flashing cursor.

7.14 NEAREST AIRSPACES



Figure 7-16 Nearest Airspaces Page

Select the Nearest Airspaces Page

- 1) Turn the large **FMS** Knob to select the 'NRST' page group.
- 2) Turn the small **FMS** Knob to select the seventh rectangular page icon.

Airspace Alerts Box

- If the projected course takes the aircraft inside an airspace within the next ten minutes, 'Ahead' is displayed.
- If the aircraft is within two nautical miles of an airspace and the current course takes the aircraft inside, 'Ahead < 2 nm' is displayed.

- If the aircraft is within two nautical miles of an airspace and the current course will not take the aircraft inside, 'Within 2 nm' is displayed.
- If the aircraft has entered an airspace, 'Inside' is displayed.

View Additional Details for a Listed Airspace

- 1) With the Nearest Airspace Page displayed, press the **FMS** Knob to activate the cursor.
- 2) Turn the large **FMS** Knob to scroll through the list, highlighting the desired airspace.
- 3) Select the **ALERTS** Softkey to place the cursor in the 'AIRSPACE ALERTS' field.
- 4) Turn either **FMS** Knob to select the desired airspace.
- 5) Press the **FMS** Knob to remove the flashing cursor.

View and Quickly Load the Frequency for a Controlling Agency

- 1) With the Nearest Airspace Page displayed, select the **FREQ** Softkey to place the cursor in 'FREQUENCIES' field.
- 2) Turn either **FMS** Knob to select the desired frequency.
- 3) Press the **ENT** Key to load the frequency into the COM frequency standby field.
- 4) Press the **FMS** Knob to remove the flashing cursor.

SECTION 8: FLIGHT PLANNING

The following discussions pertain to the Multi Function Display, unless otherwise indicated.

8.1 USER DEFINED WAYPOINTS

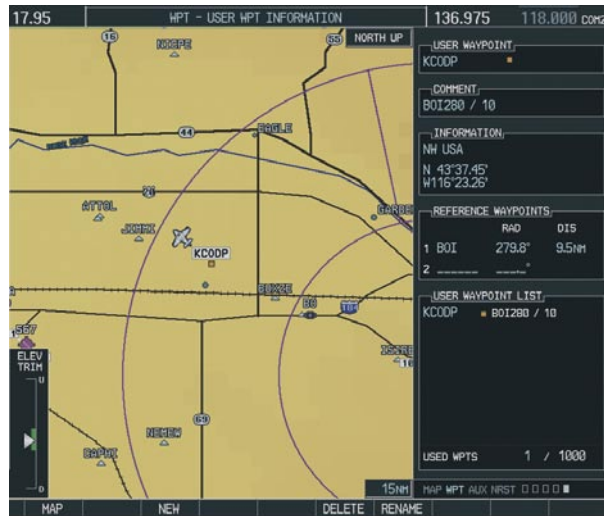

Figure 8-1 User WPT Information Page

Select the User WPT Information Page

- 1) Turn the large **FMS** Knob to select the 'WPT' page group.
- 2) Turn the small **FMS** Knob to select the fifth rectangular page icon.

Create a New User Waypoint

- 1) With the User Waypoint Information Page displayed, select the **NEW** Softkey. A waypoint is created at the current aircraft position.
- 2) Turn the small **FMS** Knob to enter first character of the waypoint name.
- 3) Turn the large **FMS** Knob to move the cursor to the next character field.

- 4) Repeat steps 2 and 3 until the desired name is entered.
- 5) Press the **ENT** Key.
- 6) Press the **ENT** Key a again to accept the new waypoint identifier.
- 7) The cursor is now in the 'REFERENCE WAYPOINTS' field. If desired, the waypoint can be defined by a reference waypoint. Turn the **FMS** Knobs to enter the position coordinates or the radial and distance from the reference waypoint.
- 8) Press the **FMS** Knob to remove the flashing cursor.

Modify a User Waypoint

- 1) With the User Waypoint Information Page displayed, press the **FMS** Knob to activate the cursor.
- 2) Turn the large **FMS** Knob to move the cursor to the desired field and turn the small **FMS** Knob to make changes.
- 3) Press the **ENT** Key to accept the changes.
- 4) Press the **FMS** Knob to remove the flashing cursor.

Delete a User Waypoint

- 1) Select the User Waypoint Information Page and press **MENU** to display the User Waypoint Information Page Options or select the **DELETE** Softkey.
- 2) Turn the large **FMS** Knob to select 'Delete User Waypoint' and press the **ENT** Key. The message 'Would you like to delete the user waypoint' is displayed. With 'YES' highlighted, press the **ENT** Key.

Create User Waypoints from the Navigation Map Page

- 1) With the Navigation Map Page displayed, push the **Joystick** to activate the panning function. The map pointer is displayed at the present aircraft position.
- 2) Move the **Joystick** to place the pointer at the desired position.
- 3) Press the **ENT** Key. The User Waypoint Information Page is now displayed with the captured position.
- 4) Turn the **FMS** Knobs to select a waypoint name.
- 5) Press the **ENT** Key to accept the selected name. The first reference waypoint field is highlighted.
- 6) If desired, turn the **FMS** Knobs to enter the identifier of the reference waypoint and the radial and distance to the reference waypoint. Press the **ENT** Key to accept.
- 7) Press the **FMS** Knob to remove the flashing cursor.

8.2 VIEWING THE ACTIVE FLIGHT PLAN

Press the **FPL** Key.



Figure 8-2 Active Flight Plan Window on the PFD



Figure 8-3 Active Flight Plan Page on the MFD

8.3 ACTIVATE A STORED FLIGHT PLAN

- 1) Press the **FPL** Key and turn the small **FMS** Knob to display the Flight Plan Catalog Page.

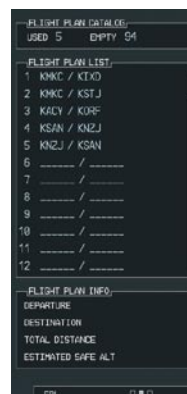

Figure 8-4 Flight Plan Catalog Page

- 2) Press the **FMS** Knob to activate the cursor.
- 3) Turn the large **FMS** Knob to highlight the desired flight plan and select the **ACTIVE** Softkey.
- 4) With 'OK' highlighted, press the **ENT** Key to activate the flight plan. To cancel the flight plan activation, turn the large **FMS** Knob to highlight 'CANCEL' and press the **ENT** Key.

8.4 ACTIVATE A FLIGHT PLAN LEG

- 1) From the Active Flight Plan Page, press the **FMS** Knob to activate the cursor and turn the large **FMS** Knob to highlight the desired destination waypoint.
- 2) Select the **ACT LEG** Softkey (using MFD only).
OR
- 3) Press the **MENU** Key, select the 'Activate Leg' option from the page menu and press the **ENT** Key. This step must be used when activating a leg from the PFD.
- 4) With 'Activate' highlighted, press the **ENT** Key.

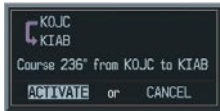

Figure 8-5 Activate Flight Plan Leg Confirmation

8.5 STOP NAVIGATING A FLIGHT PLAN

- 1) Press the **FPL** Key to display the Active Flight Plan Page.
- 2) Press the **MENU** Key to display the Page Menu Window.

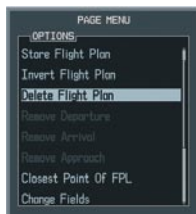

Figure 8-6 Delete Flight Plan

- 3) Turn the large **FMS** Knob to highlight 'Delete Flight Plan' and press the **ENT** Key. With 'OK'

highlighted, press the **ENT** Key to deactivate the flight plan. This will not delete the stored flight plan, only the active flight plan.

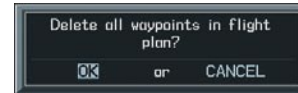

Figure 8-7 Delete Flight Plan Confirmation

8.6 INVERT ACTIVE FLIGHT PLAN

- 1) From the Active Flight Plan Page, press the **MENU** Key to display the Page Menu.
- 2) Turn the large **FMS** Knob to highlight 'Invert Flight Plan' and press the **ENT** Key. The original flight plan remains intact in its flight plan catalog storage location.
- 3) With 'OK' highlighted, press the **ENT** Key to invert the flight plan.

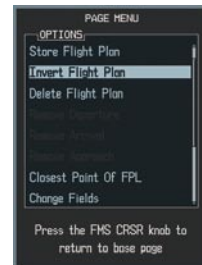

Figure 8-8 Invert Flight Plan

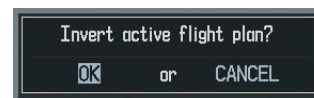

Figure 8-9 Invert Flight Plan Confirmation

8.7 CREATE A NEW FLIGHT PLAN

Create a New Flight Plan Using the MFD

- 1) Press the **FPL** Key and turn the small **FMS** Knob to display the Flight Plan Catalog Page.
- 2) Select the **NEW** Softkey to display a blank flight plan window for the first empty storage location.

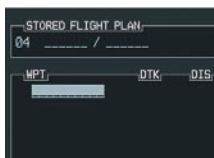

Figure 8-10 Create FPL on MFD

- 3) Turn the small **FMS** Knob to display the Waypoint Information Window.
- 4) Turn the small **FMS** Knob to enter the first character of the identifier of the departure waypoint.
- 5) Turn the large **FMS** Knob to move the cursor to the next character field. Repeat steps 4 and 5 until the desired identifier has been entered.



Figure 8-11 Waypoint Info Window

- 6) Press the **ENT** Key.
- 7) Repeat steps 3 through 5 to enter the identifier for each additional flight plan waypoint.
- 8) When all waypoints have been entered, press the **FMS** Knob to return to the Flight Plan

Catalog Page. The new flight plan is now in the list.

Create a New Flight Plan Using the PFD



NOTE: A flight plan cannot be entered using the PFD if another flight plan is active.



NOTE: After the first leg is entered (using the PFD only), it is immediately activated.

- 1) Press the **FPL** Key, then press the **FMS** Knob to activate the cursor.
- 2) Turn the small **FMS** Knob to enter the first letter of the destination waypoint identifier. Turn the large **FMS** Knob to the right to move the cursor to the next character position.
- 3) Repeat step 2 to spell out the rest of the waypoint identifier.
- 4) Press the **ENT** Key and the cursor is now ready for entering of the next flight plan waypoint.
- 5) Repeat steps 2 through 4 to enter the identifier for each additional flight plan waypoint.
- 6) Once all waypoints have been entered, press the **FMS** Knob remove the cursor. The new flight plan is now active.

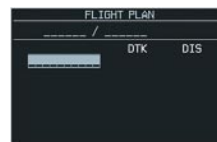

Figure 8-12 Creating Flight Plan on the PFD

8.8 LOAD A DEPARTURE

See the Procedures section for a discussion on loading and activating departure procedures.

8.9 LOAD AN ARRIVAL

See the Procedures section for a discussion on loading and activating arrival procedures.

8.10 LOAD AN APPROACH

See the Procedures section for a discussion on loading and activating approach procedures.

8.11 REMOVE A DEPARTURE, ARRIVAL, OR APPROACH FROM A FLIGHT PLAN

- 1) With the Active or Stored Flight Plan Page displayed, press the **FMS** Knob to activate the cursor.
- 2) Turn the large **FMS** Knob to highlight the title for the approach, departure or arrival to be deleted. Titles appear in white directly above the procedure's waypoints.
- 3) Press the **CLR** Key to display a confirmation window. With 'OK' highlighted, press the **ENT** Key to remove the selected procedure.

8.12 STORE A NEWLY CREATED FLIGHT PLAN

- 1) After creating a flight plan on either the PFD or MFD, it may be saved by pressing the **MENU** Key.
- 2) Turn the large **FMS** Knob to highlight 'Store Flight Plan' and press the **ENT** Key.
- 3) With 'OK' highlighted, press the **ENT** Key to store the flight plan.

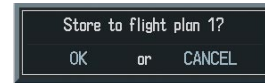

Figure 8-13 Store Flight Plan Confirmation

8.13 EDIT A STORED FLIGHT PLAN

- 1) Press the **FPL** Key and turn the small **FMS** Knob to display the Flight Plan Catalog Page.
- 2) Press the **FMS** Knob to activate the cursor.
- 3) Turn the large **FMS** Knob to highlight the desired flight plan and press the **ENT** Key.
- 4) Turn the large **FMS** Knob to place the cursor in the desired locations for entering changes.
- 5) Turn the **FMS** Knobs to make the desired changes, then press the **ENT** Key.
- 6) Press the **FMS** Knob to return to the Flight Plan Catalog Page.

8.14 DELETE A WAYPOINT FROM THE FLIGHT PLAN

- 1) With either the Active or Stored Flight Plan displayed, press the **FMS** Knob to activate the cursor.
- 2) Turn the large **FMS** Knob to select the waypoint to be deleted.
- 3) Press the **CLR** Key to display a 'REMOVE (Wpt Name)' confirmation window.

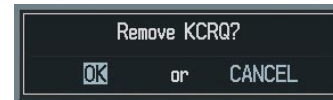

Figure 8-14 Remove Waypoint Confirmation

- 4) With 'OK' highlighted, press the **ENT** Key to remove the waypoint. To cancel the delete request, turn the large **FMS** Knob to highlight 'CANCEL' and press the **ENT** Key.

- Once all changes have been made, press the **FMS** Knob to remove the cursor.

8.15 INVERT AND ACTIVATE A STORED FLIGHT PLAN

- From the Flight Plan Catalog Page, press the **FMS** Knob to activate the cursor.
- Turn the large **FMS** Knob to highlight the desired flight plan.
- Select the **INVERT** Softkey. 'Invert and activate stored flight plan?' will be displayed.
- With 'OK' highlighted, press the **ENT** Key. The selected flight plan is now inverted and activated. The original flight plan remains intact in its flight plan catalog storage location.

8.16 COPY A FLIGHT PLAN

- From the Flight Plan Catalog press the **FMS** Knob to activate the cursor
- Turn the large **FMS** Knob to highlight the flight plan to be copied.
- Select the **COPY** Softkey.
- A 'Copy to flight plan #?' confirmation window is displayed. With 'OK' highlighted, press the **ENT** Key to copy the flight plan. To cancel, turn the large **FMS** Knob to highlight 'CANCEL' and press the **ENT** Key.

8.17 DELETE A FLIGHT PLAN

- From the Flight Plan Catalog Page, press the **FMS** Knob to activate the cursor.
- Turn the large **FMS** Knob to highlight the flight plan to be deleted.

- Select the **DELETE** Softkey.
- A 'Delete flight plan #?' confirmation window is displayed. With 'OK' highlighted, press the **ENT** Key to delete the flight plan. To cancel, turn the large **FMS** Knob to highlight 'CANCEL' and press the **ENT** Key.

8.18 GRAPHICAL FLIGHT PLAN CREATION

- Press the **FPL** Key to display the Active Flight Plan Page.
- Press the **Joystick** to activate the map pointer. Use the **Joystick** to move the pointer to the desired point on the map to be inserted as a waypoint in the flight plan.
- Select the **LD WPT** Softkey. The selected waypoint will be inserted at the end of the flight plan. The default user waypoint naming is USR000, USR001, USR002 and so on.
- If the selected waypoint is to be placed elsewhere in the flight plan, press the **FMS** Knob to activate the cursor. Waypoints are inserted *ABOVE* the cursor.
- After placing the cursor at the desired point in the list of waypoints, select the **LD WPT** Softkey.
- To change the user waypoint name, follow the procedure for modifying a user waypoint.

8.19 TRIP PLANNING

- Turn the large **FMS** Knob to select the 'AUX' page group.
- Turn the small **FMS** Knob to select the first rectangular page icon.

- 3) The current page mode is displayed at the top of the page: 'AUTOMATIC' or 'MANUAL'. To change the page mode, select the **AUTO** or **MANUAL** Softkey.



Figure 8-15 Trip Planning Page

- 4) For Direct-to planning, select the **WPTS** Softkey and verify that the starting waypoint field indicates 'P.POS' (present position). If necessary, press the **MENU** Key and select 'Set WPT to Present Position' to display 'P.POS'. Press the **ENT** Key and the flashing cursor moves to the ending waypoint field. Turn the **FMS** Knobs to enter the identifier of the ending waypoint and press the **ENT** Key to accept the waypoint. OR,
- 5) For point-to-point planning, turn the **FMS** Knobs to enter the identifier of the starting waypoint. Once the waypoints identifier is entered, press the **ENT** Key to accept the waypoint. The flashing cursor moves to the ending waypoint. Again, turn the **FMS** Knobs

to enter the identifier of the ending waypoint and press the **ENT** Key to accept the waypoint. OR,

- 6) For flight plan leg planning, select the **FPL** Softkey (at the bottom of the display) and turn the small **FMS** Knob to select the desired flight plan (already stored in memory), by number. Turn the large **FMS** Knob to highlight the 'LEG' field and turn the small **FMS** Knob to select the desired leg of the flight plan, or select 'CUM' to apply trip planning calculations to the entire flight plan. Selecting 'FPL 00' will display an active flight plan. If an active flight plan is selected, 'REM' will be an available option to display planning data for the remainder of the flight plan.



NOTE: The Page Mode must be set to **MANUAL** to perform the following steps.

- 7) Turn the large **FMS** Knob to highlight the departure time (DEP TIME) field.
- 8) Turn the **FMS** Knobs to enter the departure time. Press the **ENT** Key when finished. (Departure time may be entered in local or UTC time, depending upon system settings).
- 9) Turn the **FMS** Knobs to enter the fuel flow. Press the **ENT** Key when finished. Note that in automatic page mode, fuel flow is provided by the system.
- 10) The flashing cursor moves to the fuel on board field. Turn the **FMS** Knobs to modify the fuel on board. Press the **ENT** Key when finished. In 'AUTOMATIC' mode, fuel onboard is provided by the entry made in 'GAL REM' on the EIS System Page.

- 11) The flashing cursor moves to the calibrated airspeed field. Turn the **FMS** Knobs to enter a calibrated airspeed. Press the **ENT** Key when finished.

8.20 VERTICAL NAVIGATION (VNAV) PAGE



NOTE: An active flight plan or Direct-to must be entered in order to utilize VNAV.



NOTE: VNAV is advisory only and cannot be coupled to the autopilot.

- 4) With the 'TARGET POSITION' distance field highlighted, turn the **FMS** Knobs to select the desired distance for Top Of Climb or Bottom Of Descent from the VNAV profile endpoint. The default distance is 4 nm.
- 5) Press the **ENT** Key. The cursor is now positioned over the 'Before' and 'After' field.
- 6) Turn the small **FMS** Knob to select whether the previously set distance is 'Before' or 'After' the endpoint.
- 7) Press the **ENT** Key. The cursor is now placed over the VNAV profile endpoint field.

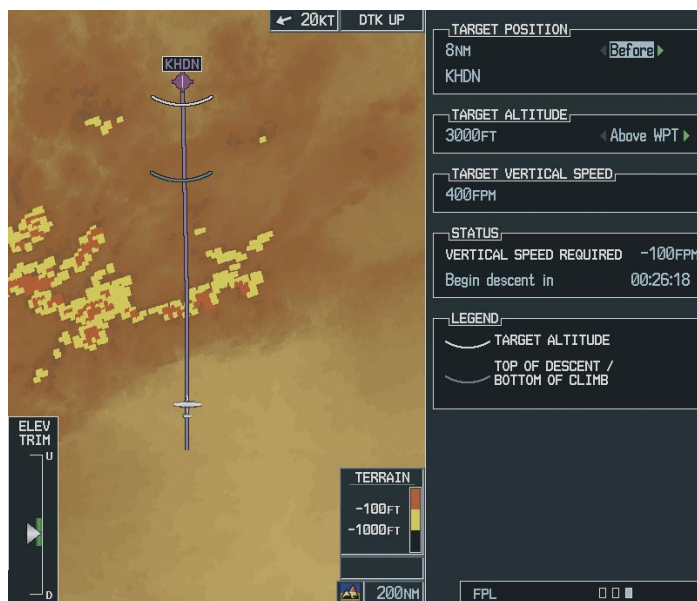

Figure 8-16 Vertical Navigation (VNAV) Page

Create a Vertical Navigation Profile

- 1) Press the **FPL** Key.
- 2) Turn the small **FMS** Knob to select the third page icon.
- 3) Press the **FMS** Knob to activate the cursor.
- 8) Turn the small **FMS** Knob to display a list of possible VNAV profile endpoints. When using a flight plan, the target reference waypoint itself can be specified from the waypoints contained in the flight plan. By default, the last waypoint

in the flight plan is selected. Highlight the desired waypoint.

- 9) Press the **ENT** Key.
- 10) With the 'TARGET ALTITUDE' field highlighted, turn the small and large **FMS** Knobs to select the target altitude. If the selected altitude is above the current aircraft altitude, a profiled climb is created. If the selected altitude is below the current aircraft altitude, a profiled descent will be created.
- 11) Press the **ENT** Key. The cursor is now placed in the 'TARGET VERTICAL SPEED' field. The default profile utilizes a 400 foot-per-minute descent rate.
- 12) To change the vertical speed, turn the **FMS** Knobs to enter the desired vertical speed. Press the **ENT** Key when finished.

With the profile set, the vertical speed required (VSR) is displayed. Expect the following to occur when using the vertical navigation feature:

At one minute prior to reaching the Bottom Of Climb or Top Of Descent point (gray arc), the message 'APPR VPROF - Approaching VNAV Profile' is displayed as a PFD alert. The descent (or climb) angle also locks to prevent changes in speed from altering the profile. If selected, the vertical speed required (VSR) readout on the default NAV and map pages shows the desired vertical speed to maintain the proper descent (or climb) angle. At 500 feet above (or below, for a climb) the target altitude (white arc), an 'APPR TRG ALT' - Approaching Target Altitude" message is provided. The VSR readout on the Navigation Map Page is blanked out at this point.

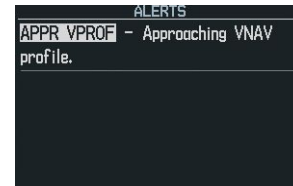

Figure 8-17 Approaching VNAV Profile Message (PFD)

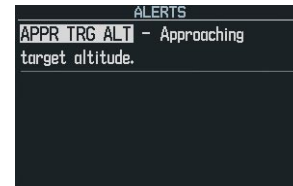

Figure 8-18 Approaching Target Altitude Message (PFD)

To display map data on the Vertical Navigation Map Page, select the **MAP** Softkey. Select the **TOPO**, **TERRAIN**, or **LTNG** Softkey. Select the same softkey to remove the displayed data from the Vertical Navigation Page.

VNAV Page Menu Options

The VNAV messages are not enabled until the 'VNAV Messages On?' option is enabled from the VNAV Page Menu Options. To display the page menu, press the **MENU** Key (with the VNAV Page displayed). The VNAV Page Options Menu also allows the pilot to restore VNAV page defaults.

Blank Page

SECTION 9: PROCEDURES

9.1 ARRIVALS AND DEPARTURES

Load and Activate a Departure Procedure

- 1) With the Navigation Map Page displayed, press the **FPL** Key.
- 2) Select the **LD DP** Softkey. If a flight plan is active, the departure airport will be displayed as the default. A list of available departures is also displayed.
- 3) If no flight plan is active, use the **FMS** Knobs to enter the identifier of the desired airport. Press the **ENT** Key.
- 4) Turn the large **FMS** Knob to highlight the Departure field. Turn the small **FMS** Knob to display a list of available departures.
- 5) Turn either **FMS** Knob to select the desired departure and press the **ENT** Key.



Figure 9-1 Select Departure

- 6) A list of runways may be displayed for the departure. Turn either **FMS** Knob to select the desired runway and press the **ENT** Key.
- 7) A list of available transitions is displayed for the departure. Turn either **FMS** Knob to highlight the desired transition waypoint and press the **ENT** Key.



Figure 9-2 Select Departure Transition

- 8) With 'LOAD?' highlighted, press the **ENT** Key. The departure will be active when the flight plan is active.

Load and Activate An Arrival Procedure

- 1) With the Navigation Map Page displayed, press the **FPL** Key.
- 2) Select the **LD STAR** Softkey. If a flight plan is active, the destination airport will be displayed as the default. A list of available arrivals is also displayed.
- 3) If no flight plan is active, use the **FMS** Knobs to enter the identifier of the desired airport. Press the **ENT** Key.
- 4) Turn the large **FMS** Knob to highlight the Arrival field. Turn the small **FMS** Knob to display a list of available arrivals.
- 5) Turn either **FMS** Knob to select the desired arrival and press the **ENT** Key.



Figure 9-3 Select Arrival

- 6) A second window is displayed listing available transitions for the arrival. Turn either **FMS** Knob

to highlight the desired transition waypoint and press the **ENT** Key.



Figure 9-4 Select Arrival Transition

- 7) A third window is displayed listing the available runways. Turn either **FMS** Knob to select the desired runway and press the **ENT** Key.



Figure 9-5 Select Arrival Runway

- 8) With 'LOAD?' highlighted, press the **ENT** Key. If a flight plan is active, the selected arrival procedure is inserted after the destination airport and becomes part of the active flight plan. If no flight plan is active when the arrival is loaded, the arrival procedure will become the active flight plan.

9.2 APPROACHES

Not all approaches in the database are approved for GPS use. When selecting an approach, a “GPS” designation to the right of the procedure name indicates the procedure can be flown using the GPS receiver. Some procedures will not have this designation, meaning the GPS receiver can be used for supplemental navigation guidance only.

If the GPS receiver cannot be used for primary guidance, the appropriate navigation receiver must be used for the selected approach (e.g., VOR or ILS). The final course segment of ILS approaches, for example, must be flown by tuning the Nav receiver to the proper frequency and selecting that Nav receiver on the CDI.

Load and/or Activate an Approach Procedure

- 1) With the Navigation Map Page displayed, press the **FPL** Key.
- 2) Select the **LD APR** Softkey. If a flight plan is active, the destination airport will be displayed as the default. A list of available approaches is also displayed.
- 3) If no flight plan is active, use the **FMS** Knobs to enter the identifier of the desired airport. Press the **ENT** Key.
- 4) Turn the large **FMS** Knob to highlight the Approach field. Turn the small **FMS** Knob to display a list of available approaches.



Figure 9-6 Selecting an Approach Procedure

- 5) Turn either **FMS** Knob to highlight the desired approach. Press the **ENT** Key.

- 6) The cursor will move to the TRANSITIONS field. Turn the large **FMS** Knob to highlight the desired transition waypoint and press the **ENT** Key. (The “Vectors” option assumes vectors will be received to the final course segment of the approach and will provide navigation guidance relative to the final approach course.)



Figure 9-7 Selecting an Approach Transition

- 7) Turn the large **FMS** Knob to highlight ‘Activate?’ and press the **ENT** Key to activate the approach. Selecting ‘Load?’ will add the procedure to the flight plan without immediately using it for navigation guidance.

Activate An Approach in the Active Flight Plan

- 1) With the Navigation Map Page displayed, press the **PROC** Key.
- 2) Turn the large **FMS** Knob to highlight ‘ACTIVATE APPROACH’.
- 3) Press the **ENT** Key. The approach procedure is now active.

Blank Page

SECTION 10: HAZARD AVOIDANCE

10.1 CUSTOMIZING THE HAZARD DISPLAYS ON THE NAVIGATION MAP

- 1) With the Navigation Map Page displayed, press the **MENU** Key to display the Navigation Map Page Menu. The cursor flashes on the 'Map Setup' option.
- 2) Press the **ENT** Key. The Map Setup Menu is displayed. Turn the small **FMS** Knob to select the 'Weather' or 'Traffic' group to customize the display of weather features. Select 'Traffic' to customize the display of traffic.
- 3) Press the small **FMS** Knob to return to the Navigation Map Page.

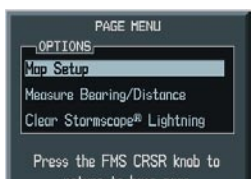

Figure 10-1 Page Menu



Figure 10-2 Map Setup Menu



Figure 10-3 Map Setup Group List

10.2 STORMSCOPE® (OPTIONAL, 350 ONLY)



WARNING: The Stormscope system is not intended to be used for hazardous thunderstorm penetration. Weather information on the G1000 MFD is approved for weather avoidance only. Refer to the WX-500 Pilot's Guide for detailed operation.

Displaying Stormscope Lightning Data on the Navigation Map Page

- 1) Select the **MAP** Softkey.
- 2) Select the **STRMSCP** Softkey. Select the **STRMSCP** Softkey again to remove Stormscope Lightning Data from the Navigation Map Page.

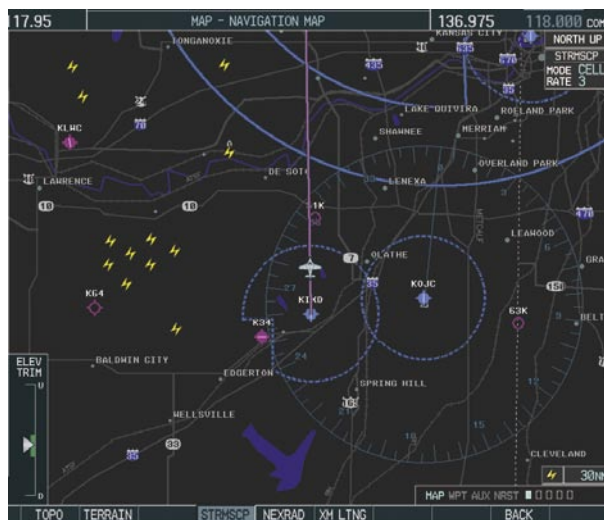

Figure 10-4 In-Flight Navigation Map Page Displaying Stormscope Lightning Data

Lightning Age	Symbol
Strike is less than 6 seconds old	
Strike is between 6 and 60 seconds old	
Strike is between 1 and 2 minutes old	
Strike is between 2 and 3 minutes old	

At a map range of less than 25 nm, Stormscope lightning data is not displayed, but can still be present. The presence of Stormscope lightning data is indicated by the annunciation 'LTNG < 25 nm' in the upper right corner.



Figure 10-5 Lightning Display Range Annunciation

Select 'cell' or 'strike' as the Stormscope lightning mode on the Navigation Map:

- 1) From the Navigation Map Page, press the **MENU** Key. Select Map Setup and press the **ENT** Key.
- 2) Turn the small **FMS** Knob to select 'Weather' and press the **ENT** Key.
- 3) Turn the large **FMS** Knob to select 'STRMSCP MODE'.
- 4) Turn either **FMS** Knob to display the Cell/Strike Window.
- 5) Turn either **FMS** Knob to select 'Cell' or 'Strike'. Press the **ENT** Key.
- 6) Push the **FMS** Knob to return to the Navigation Map Page.

Clear Stormscope lightning data from the Navigation Map Page:

- 1) Press the **MENU** Key (with the Navigation Map Page displayed).
- 2) Turn either **FMS** Knob to highlight the 'Clear Lightning Data' field and press the **ENT** Key.

Stormscope Page

- 1) Turn the large **FMS** Knob until the Map Page group is selected.
- 2) Turn the small **FMS** Knob until the Stormscope Page is selected.



Figure 10-6 Stormscope Page

Change the Stormscope lightning mode between 'cell' and 'strike':

- 1) Select the Stormscope Page.
- 2) Select the **MODE** Softkey. The **CELL** and **STRIKE** Softkeys are displayed. Select the **CELL** Softkey to display 'CELL' data or select the **STRIKE** Softkey to display 'STRIKE' data. 'CELL' or 'STRIKE' is displayed in the mode box located in the upper left corner of the Stormscope Page.



NOTE: "Cell mode" uses a clustering program to identify clusters of electrical activity that indicate cells.

Change the viewing mode between 360° and 120°:

- 1) Select the Stormscope Page.
- 2) Select the **VIEW** Softkey. The **360** and **ARC** Softkeys are displayed. Select the **360** Softkey to display a 360° viewing area or select the **ARC** Softkey to display a 120° viewing area.
Select the **CLEAR** Softkey to remove all Stormscope lightning data from the display.

10.3 XM® WEATHER (OPTIONAL)



WARNING: XM Weather is not intended to be used for hazardous weather penetration. Weather information provided by XM Radio Service is approved only for weather avoidance, not penetration.

- 1) Select the **MAP** Softkey.
- 2) Select the **NEXRAD** or **XM LTNG** Softkey to display the desired weather. Select the applicable softkey again to remove weather data from the Navigation Map Page.

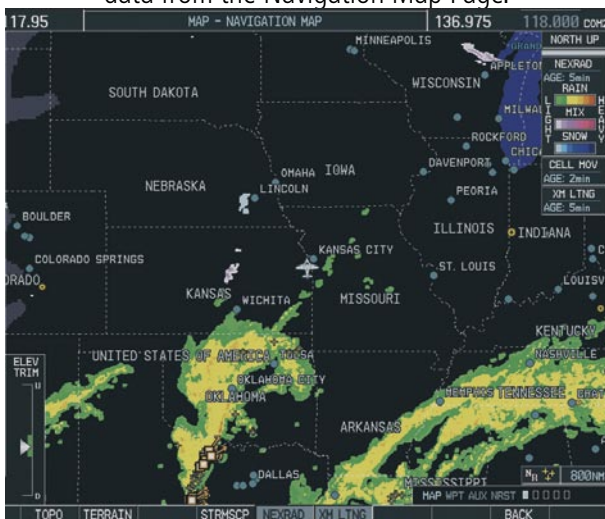

Figure 10-7 Navigation Map Page Displaying NEXRAD Weather

Displaying METAR and TAF information on the Airport Information Page

Display METAR and TAF text on the Airport Information Page:

- 1) Turn the large **FMS** Knob to select the WPT Page Group.
- 2) Turn the small **FMS** Knob to select the Airport Information Page.
- 3) Select the **WX** Softkey to display METAR and TAF text (METAR and TAF information is updated every 12 minutes).

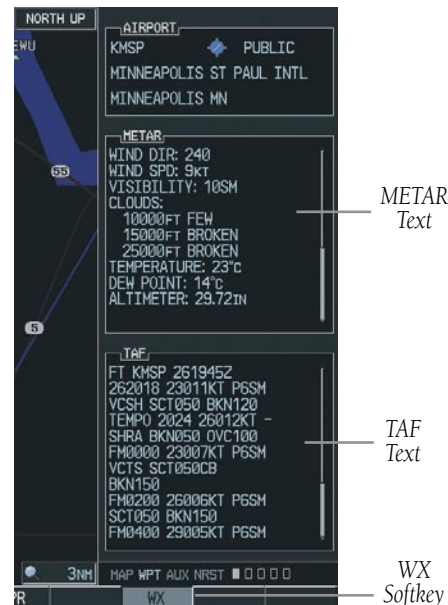

Figure 10-8 METAR and TAF Text Displayed on the Airport (Weather) Information Page

Displaying Weather on the Weather Data Link Page

- 1) Turn the large **FMS** Knob to select the Map Page Group.
- 2) Turn the small **FMS** Knob to select the Weather Data Link Page.
- 3) Select the available softkeys to select the desired XM weather product.
- 4) Select the **LEGEND** Softkey to view the legends for the selected products. If necessary, turn either **FMS** Knob to scroll through the list. Press the small **FMS** Knob or the **ENT** Softkey to return to the map.

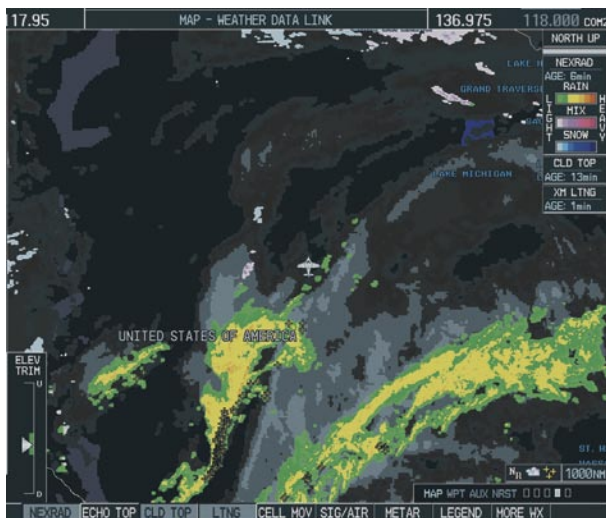

Figure 10-9 Weather Data Link Page

NEXRAD – Select the **NEXRAD** Softkey to show NEXRAD weather and radar coverage information. Areas where radar coverage is not available will be shown in grayish-purple. The display is updated every five minutes.

NEXRAD Limitations

Certain limitations exist regarding the NEXRAD radar displays. Some, but not all, are listed here:

- NEXRAD base reflectivity does not provide sufficient information to determine cloud layers or precipitation characteristics (hail vs. rain, etc).
- An individual NEXRAD site cannot depict high altitude storms at close ranges, and has no information about storms directly over the site.
- The resolution of displayed NEXRAD data is 4 square kilometers. Therefore, when zoomed in on the display, each square block is 2 kilometers on each side. The intensity level reflected by the square will be the highest level sampled within the square area.

ECHO TOP – Select the **ECHO TOP** Softkey to show the location, elevation, and direction the highest radar echo. This may not indicate the top of a storm or clouds, only the highest radar return echo. ECHO TOPS cannot be displayed along with NEXRAD and CLOUD TOPS. When ECHO TOPS is activated, NEXRAD and CLOUD TOPS are removed. Refer to the Legend for a description of the ECHO TOPS coding. The display is updated every 7.5 minutes.

CLD TOP – Select the **CLD TOP** Softkey to show the cloud top altitude determined from satellite imagery. The display is updated every 15 minutes.

LTING – Selecting the **LTING** Softkey shows the location of cloud-to-ground lightning strikes. The display is updated every five minutes.



NOTE: Strikes depicted represent cloud to ground strikes within a 2 kilometer radius of the actual strike location. Therefore, the exact location of the strike is not displayed.

CELL MOV – Selecting the **CELL MOV** Softkey shows storm cell movement by displaying an arrow pointing in the direction of predicted movement. The display is updated every 12 minutes.

SIG/AIR – Selecting the **SIG/AIR** Softkey shows SIGMET and AIRMET information. The display is updated every 12 minutes.

METAR – Select the **METAR** Softkey to graphically display METARs. METARs are shown as colored flags at airports providing METAR reports. The display is updated every 12 minutes.

MORE WX – Select the **MORE WX** Softkey to display the following group of softkeys for additional weather control:

SFC – Selecting the **SFC** Softkey for Surface Analysis shows current or forecast conditions. Forecasts are available for intervals of Current, 12, 24, 36, and 48 hours. Select the softkey corresponding to the desired forecast. The closest city forecast information is displayed in the legend. The display is updated every 12 minutes.

FRZ LVL – Select the **FRZ LVL** Softkey to display contour lines for freezing levels. The display is updated every 12 minutes.

WIND – Select the **WIND** Softkey to show wind speed and direction at a selected altitude from the ground up to 42,000 feet in 3,000 foot increments. After selecting the **WIND** Softkey, select the softkey corresponding to the desired winds aloft altitude. The display is updated every 12 minutes.

COUNTY – Selecting the **COUNTY** Softkey provides specific public awareness and protection weather warnings for Tornado, Severe Thunderstorm, and Flood conditions provided by the National Weather Service (NWS). The display is updated

every 5 minutes.

CYCLONE – Selecting the **CYCLONE** Softkey shows the current location of cyclones (hurricanes and tropical storms) and their projected track at various time intervals. The update rate is every 12 minutes.

Map Panning Information – Weather Data Link Page

- 1) Push in the **Joystick** to display the panning arrow.
- 2) Move the **Joystick** to place the panning arrow on AIRMETs, TFRs, METARs, or SIGMETs. Press the **ENT** Key to display pertinent information for the selected product.

Note that pressing the **ENT** Key when panning over an AIRMET or a SIGMET displays an information box that displays the text of the report. Panning over an airport with METAR information does not display more information but allows the user to press the **ENT** Key and select that Airport's Information Page to display the text of the report. Pressing the **ENT** Key when panning over a TFR displays TFR specific information.

Weather Products and Symbols

Figure 10-10 depicts the symbol for each weather product (read from left to right). When a weather product is active, the product symbol is displayed in the lower right of the screen.

- NEXRAD
- Cloud Top/Echo Top
- XM Lightning
- Cell Movement
- SIGMETs/AIRMETs
- METARs

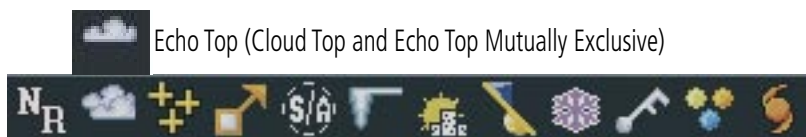

Echo Top (Cloud Top and Echo Top Mutually Exclusive)

Figure 10-10 Weather Product Symbols

- City Forecast
- Surface Analysis
- Freezing Levels
- Winds Aloft
- County Warnings
- Cyclone Warnings

The XM Information Page in the AUX Page Group will display the weather products available for the current subscription. A green box by the weather product means that it is available.



NOTE: The **DONE** Softkey on the **AUX - XM INFORMATION** Page is used to save the **GDL 69(A)** activation data when the **XM** services are initially set up. It is not used during normal operation of the **GDL 69(A)**, and it should have no adverse effects if inadvertently selected during flight. Refer to the **GDL 69/69A XM Satellite Radio Activation Instructions (190-00355-04, Rev E or later)** for further information.

Weather Product	Expires After (minutes)
SIGMETs/AIRMETs	60
City Forecasts	60
County Warnings	60
Cyclone Warnings	60
Echo Tops	30
Freezing Levels	60
METARs	90
Lightning	30
NEXRAD	30
Radar Coverage	30
Cell Movement	30
Surface Analysis	60
TFRs	60
Winds Aloft	60
TAFs	60
Clouds Tops	60

Weather Product Age

The age for each of the enabled products is displayed on the right side of the display. Times are based on Zulu time when the data was assembled on the ground, not the time the data was received by the XM receiver. When the age of a weather product has exceeded half of the expiration time, the product time will change from light blue to amber in color.

10.4 TRAFFIC INFORMATION SERVICE (TIS)



NOTE: If the G1000 is configured to use the optional Ryan 9900BX Traffic Advisory System, TIS will not be available for use.



NOTE: Traffic Information Service (TIS) is only available when the aircraft is within the service volume of a TIS capable terminal radar site.

Displaying Traffic on the Traffic Map Page

- 1) Turn the large **FMS** Knob to select the Map Page Group.
- 2) Turn the small **FMS** Knob to select the Traffic Map Page.
- 3) Select the **OPERATE** Softkey to begin displaying traffic. 'TIS OPERATING' is displayed in the Traffic Mode field.
- 4) Select the **STANDBY** Softkey to place the system in the Standby mode. 'TIS STANDBY' will be displayed in the Traffic Mode field.
- 5) Rotate the **Joystick** clockwise to display a larger area or rotate counter-clockwise to display a smaller area.

If data is not received for a period longer than 6 seconds, the age of the present data will be displayed in the lower left of the screen along with the annunciation that the system has entered Coast mode. The system will maintain the traffic display (up to 60 seconds) until the next data reception. If no data is received after 60 seconds, traffic will be removed from the display.

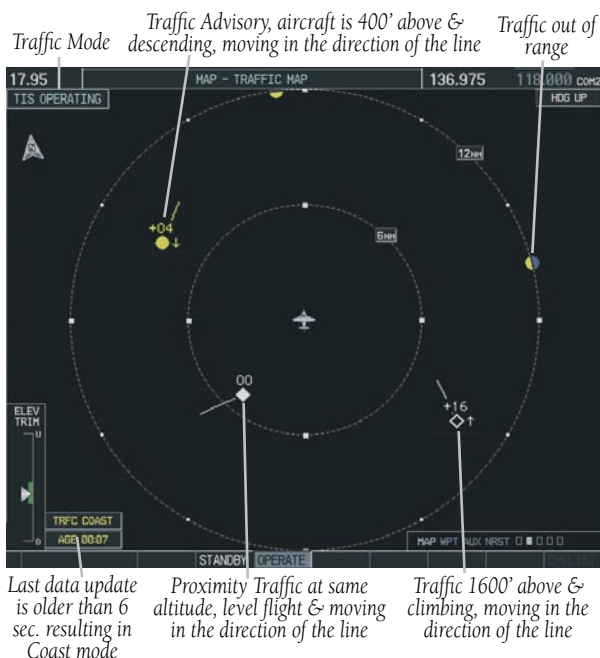

Figure 10-11 Traffic Map Page

Displaying Traffic on the Navigation Map

- 1) Ensure TIS is operating. With the Navigation Map displayed, select the **MAP** Softkey.
- 2) Select the **TRAFFIC** Softkey. Traffic will now be displayed on the map.

TIS Audio Alert

When a Traffic Advisory (TA) is displayed, an audio alert “Traffic” is given.

“Traffic Not Available” will be heard whenever TIS service becomes unavailable.

10.5 RYAN® 9900BX TRAFFIC ADVISORY SYSTEM (TAS) (OPTIONAL)

Refer to the Ryan 9900BX pilot's guide for a detailed discussion and an explanation of the aural alerts.

Displaying Traffic on the Traffic Map Page

- 1) Turn the large **FMS** Knob to select the Map Page Group.
- 2) Turn the small **FMS** Knob to select the Traffic Map Page. 'TAS OPERATING' is displayed in the Traffic Mode field.
- 3) Select the **ALT MODE** Softkey to change the altitude volume. Select the desired altitude volume by selecting the the **BELOW, NORMAL, ABOVE,** or **UREST** (unrestricted) Softkey. The selection is displayed in the Altitude Mode field.
- 4) Select the **MUTE** Softkey to mute aural alerts for currently displayed Traffic Advisories. Aural alerts will again be heard when a new Traffic Advisory is issued. Selecting the **MUTE** Softkey twice will replay the aural alerts for any currently displayed Traffic Advisories.
- 5) Rotate the **Joystick** clockwise to display a larger area or rotate counter-clockwise to display a smaller area.

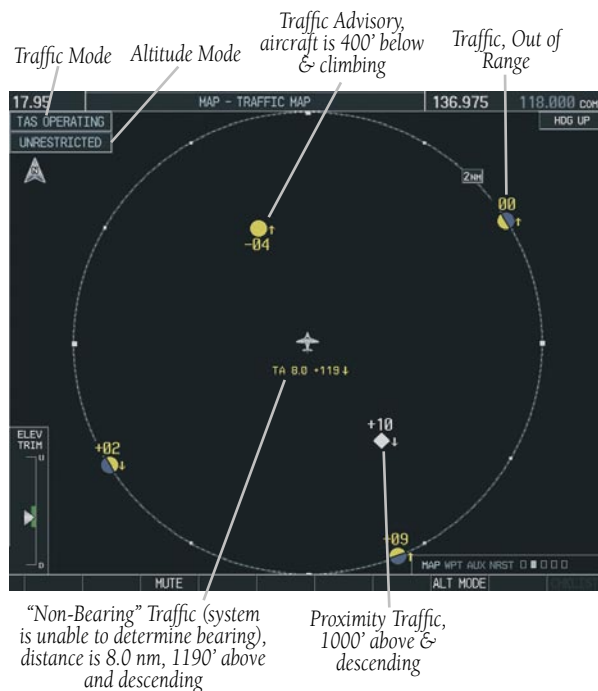

Figure 10-12 Traffic Map Page

Displaying Traffic on the Navigation Map

- 1) Ensure the TAS system is operating. With the Navigation Map displayed, select the **MAP** Softkey.
- 2) Select the **TRAFFIC** Softkey. Traffic will now be displayed on the map.

Traffic Advisory

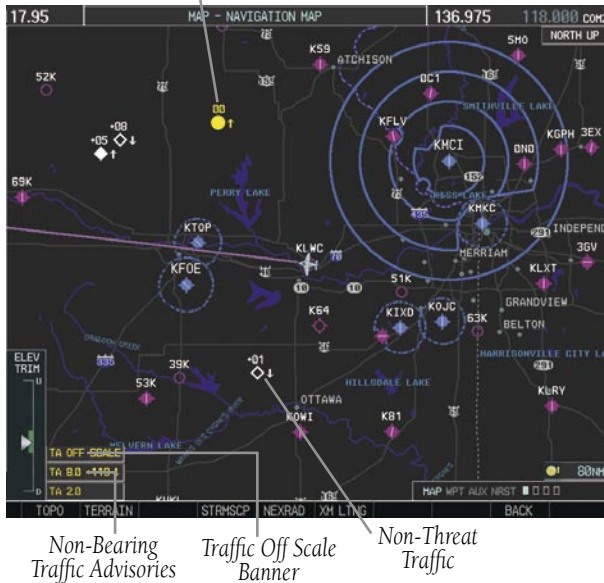

Figure 10-13 TAS Traffic on Navigation Map

- 4) Rotate the **Joystick** clockwise to display a larger area or rotate counter-clockwise to display a smaller area.

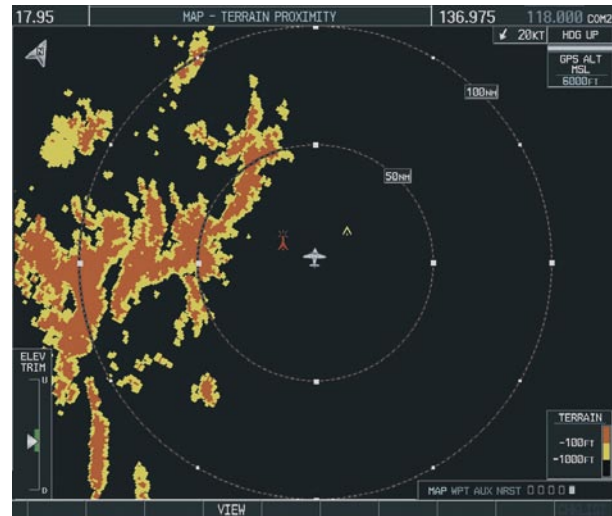

Figure 10-14 Terrain Proximity Page

10.6 TERRAIN AND OBSTACLE PROXIMITY



NOTE: Terrain data is not displayed when the aircraft latitude is greater than 75 degrees north or 60 degrees south.

Color	Indication
RED	WARNING: Terrain/Obstacle at or within 100' below or above aircraft altitude.
YELLOW	CAUTION: Terrain/Obstacle between 100' and 1000' below current aircraft altitude.

Displaying Terrain and Obstacles on the Terrain Proximity Page

- 1) Turn the large **FMS** Knob to select the Map Page Group.
- 2) Turn the small **FMS** Knob to select the last rectangular page icon.
- 3) If desired, select the **VIEW** Softkey to access the **ARC** and **360** Softkeys. When the **ARC** Softkey is selected, a radar-like 120° view is displayed. Select the **360** Softkey to return to the 360° default display.

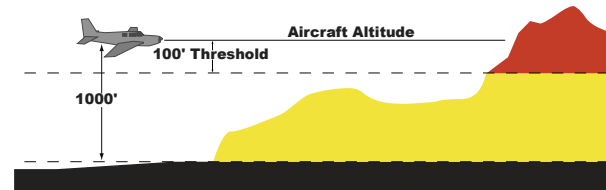

Displaying Terrain and Obstacles on the Navigation Map

- 1) With the Navigation Map displayed, select the **MAP** Softkey.
- 2) Select the **TERRAIN** Softkey. Terrain and obstacle proximity will now be displayed on the map.





Unlighted Obstacle (Height is less than 1000' AGL)	Lighted Obstacle (Height is less than 1000' AGL)	Unlighted Obstacle (Height is greater than 1000' AGL)	Lighted Obstacle (Height is greater than 1000' AGL)
			

Figure 10-15 Obstacle Symbols

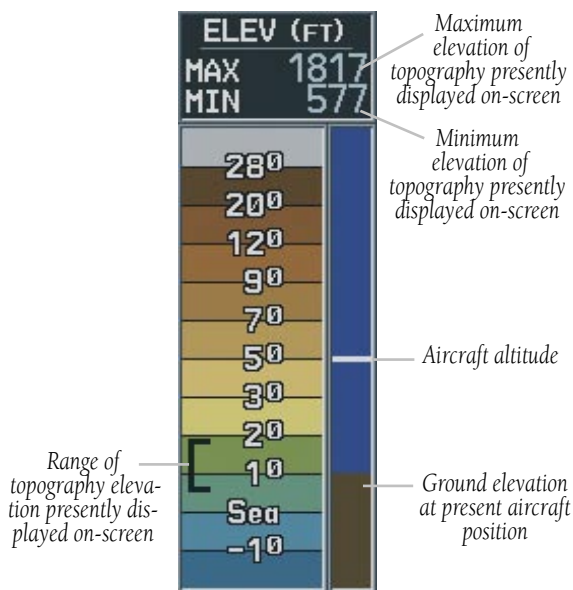

Figure 10-16 Topography Scale

10.7 TERRAIN AWARENESS & WARNING SYSTEM (TAWS) DISPLAY (OPTIONAL)



NOTE: Terrain data is not displayed when the aircraft latitude is greater than 75 degrees north or 60 degrees south.



NOTE: TAWS operation is only available when the G1000 is configured for a TAWS-B installation.

Displaying Terrain on the TAWS Page

- 1) Turn the large **FMS** Knob to select the Map Page Group.
- 2) Turn the small **FMS** Knob to select the TAWS Page.
- 3) If desired, select the **VIEW** Softkey to access the **ARC** and **360** Softkeys. When the **ARC** Softkey is selected, a radar-like 120° view is displayed. Select the **360** Softkey to return to the 360° default display.
- 4) Rotate the **Joystick** clockwise to display a larger area or rotate counter-clockwise to display a smaller area.

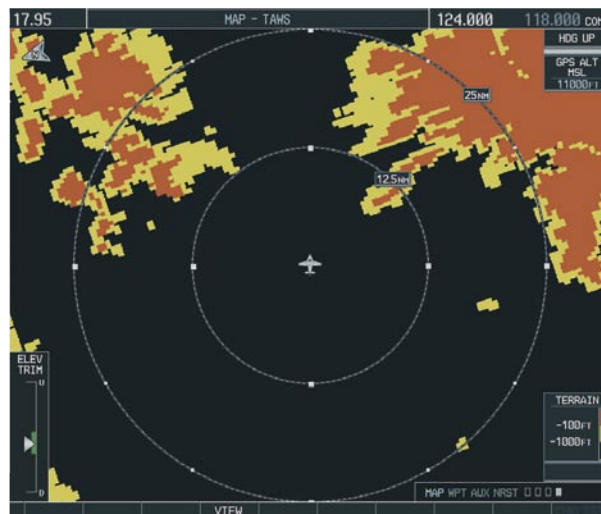

Figure 10-17 TAWS Page (360° View)

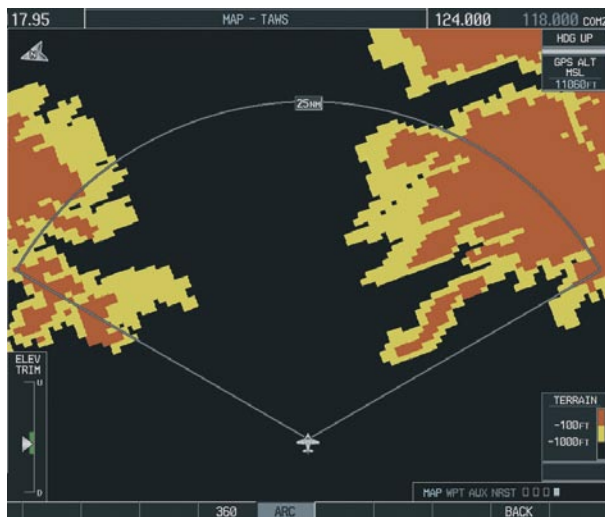

Figure 10-18 TAWS Page (ARC View)

Enable/Disable Aviation Data

- 1) While the TAWS Page is displayed, press the **MENU** Key.
- 2) Turn the small **FMS** Knob to select "Show (or Hide) Aviation Data".
- 3) Press the **ENT** Key.

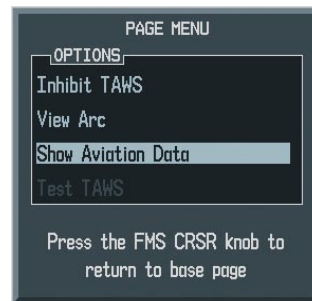
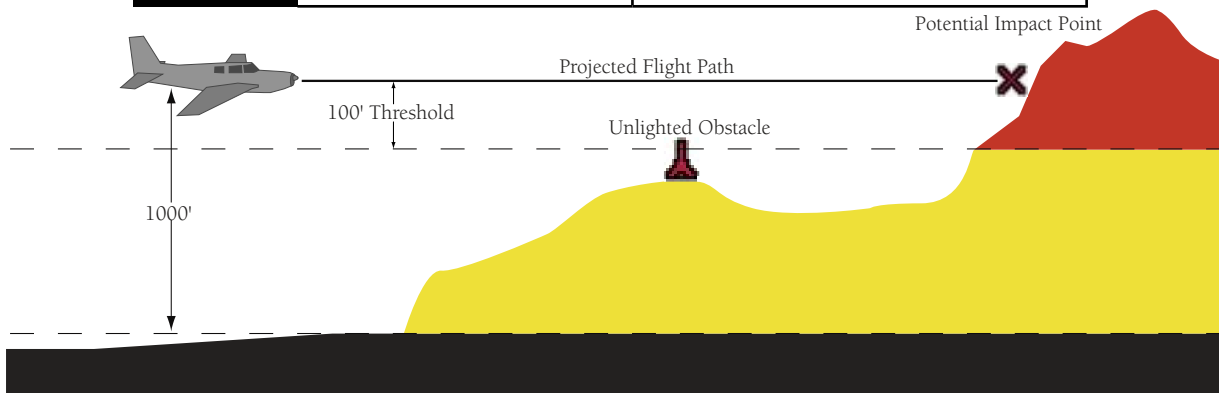

Figure 10-19 TAWS Page Menu

Color	Terrain/Obstacle Location	Suggested Pilot Response
Red	Terrain/Obstacle at or within 100' below or above aircraft altitude.	Initiate climb and/or turn away from terrain/obstacle.
Yellow	Terrain/Obstacle between 100' and 1000' below current aircraft altitude.	Be aware of surroundings. Be prepared to take action.
Black	Terrain/Obstacle is more than 1000' below aircraft altitude.	No action required.



TAWS Inhibit

Flying VFR into an area where unique terrain exists could cause the system to announce a nuisance alert. When TAWS is inhibited, only FLTA and PDA alerts are disabled.

Inhibit TAWS:

- 1) While the TAWS Page is displayed, press the **MENU** Key.
- 2) Turn the small **FMS** Knob to select 'Inhibit TAWS'.
- 3) Press the **ENT** Key.

Enable TAWS:

- 1) While the TAWS Page is displayed, press the **MENU** Key.
- 2) Turn the small **FMS** Knob to select 'Enable TAWS'.
- 3) Press the **ENT** Key.

Manual System Test

A system test is automatically performed at power-up. After successful completion of the test, "**TAWS System Test, OK**" will be heard.

The system test may also be initiated manually, but only when the aircraft is on the ground. To manually verify proper operation of the aural and visual annunciations of the system, perform the following steps.

- 1) While the TAWS Page is displayed, press the **MENU** Key.
- 2) Turn the small **FMS** Knob to select 'Test TAWS'.
- 3) Press the **ENT** Key. During the test 'TAWS TEST' is displayed in the center of the TAWS Page.
When all is in working order, "TAWS System Test, OK" will be heard.

Forward Looking Terrain Avoidance (FLTA)

The Forward Looking Terrain Avoidance alert is composed of two sub-functions:

Reduced Required Terrain Clearance (RTC) and Reduced Required Obstacle Clearance (ROC)

This provides alerts when the aircraft flight path is above terrain and/or obstacles, yet is projected to come within minimum clearance values outlined in the following table. When an RTC or ROC alert is issued, a potential impact point is displayed on the TAWS Page as a yellow or red 'X'.

Imminent Terrain Impact (ITI) and Imminent Obstacle Impact (IOI)

This provides alerts when the aircraft is below the elevation of terrain in the aircraft's projected path. ITI and IOI alerts are accompanied by a potential impact point displayed on the TAWS Page as a yellow or red 'X'. The alert is given when the projected vertical flight path is calculated to come within minimum clearance altitudes in the following table.

Phase of Flight	Level Flight	Descending
Enroute	700 ft.	500 ft.
Terminal	350 ft.	300 ft.
Approach	150 ft.	100 ft.
Departure	100 ft.	100 ft.

During the final approach phase of flight, RTC/ROC/ITI/IOI alerts are automatically inhibited when the aircraft is below 200 feet AGL while within 0.5 nm of the approach runway or is below 125 feet AGL while within 1 nm of the runway.

Premature Descent Alert (PDA)

A Premature Descent Alert is issued when the system detects that the aircraft is significantly below the normal approach path to a runway. The PDA alert mode functions only during descent to land.

PDA alerting begins when the aircraft is within 15 nm of the destination airport and ends when the aircraft is either 0.5 nm from the runway threshold OR is at an altitude of 125 feet AGL while within 1 nm of the threshold. During the final descent, algorithms will set a threshold

for alerting based on speed, distance, and other parameters.

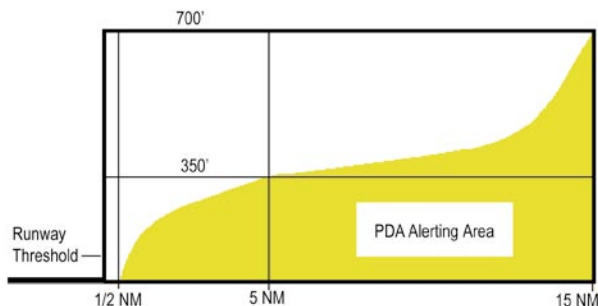

Figure 10-20 PDA Alerting

Excessive Descent Rate Alert (EDR)

The purpose of the Excessive Descent Rate alert is to provide suitable alerts when the aircraft is determined to be closing (descending) upon terrain at an excessive speed. Figure 10-21 displays the correlation between height above terrain and descent rate, resulting in the two EDR alerts. EDR alerts have two levels of severity, caution (sink rate) and warning (pull-up).

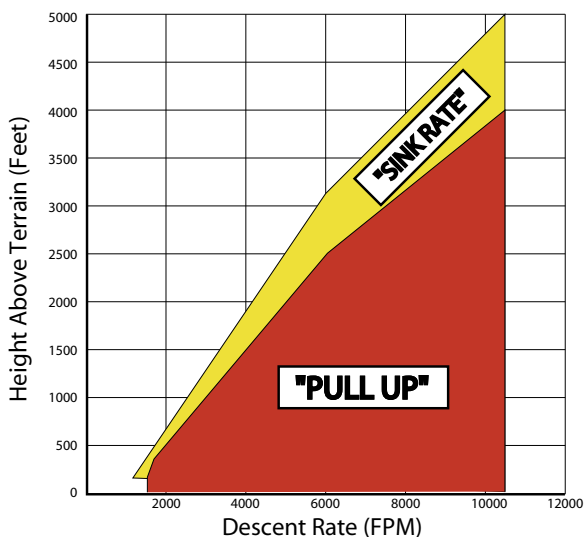

Figure 10-21 Excessive Descent Rate

Negative Climb Rate After Takeoff Alert (NCR)

The purpose of the Negative Climb Rate After Takeoff alert is to provide suitable alerts to the pilot when the system determines that the aircraft is losing altitude (closing upon terrain) after takeoff. The aural message “*Don’t Sink*” is given for NCR alerts, accompanied by an annunciation and a pop-up terrain alert on the display.

“Five-Hundred” Aural Alert

The purpose of the aural alert message “Five-hundred” is to provide an advisory alert to the aircrew that the aircraft is five-hundred feet above terrain. When the aircraft descends within 500 feet of terrain, the aural message “*Five-hundred*” is heard. There are no display annunciations or pop-up alerts that accompany the aural message.

Displaying Terrain and Obstacles on the Navigation Map

- 1) With the Navigation Map displayed, select the **MAP** Softkey.
- 2) Select the **TERRAIN** Softkey. Terrain and obstacle proximity will now be displayed on the map.





Unlighted Obstacle (Height is less than 1000' AGL)	Lighted Obstacle (Height is less than 1000' AGL)	Unlighted Obstacle (Height is greater than 1000' AGL)	Lighted Obstacle (Height is greater than 1000' AGL)	Potential Impact Points
				

Figure 10-22 TAWS Symbols

Pop-up Alerts

When the Navigation Map Page is displayed, and a terrain or obstacle alert is issued, a pop-up window is displayed with the appropriate alert.

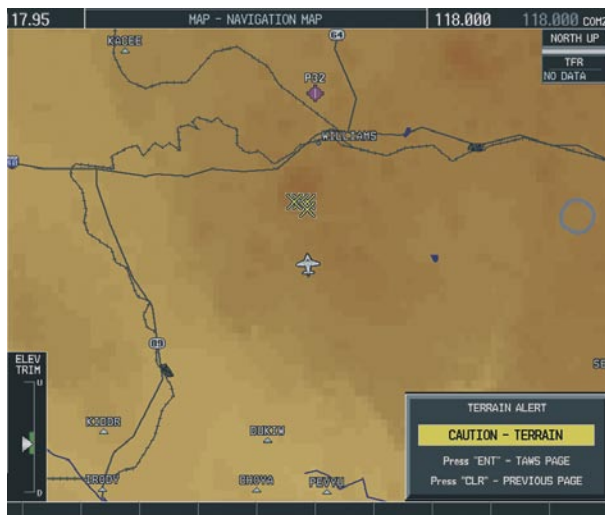

Figure 10-23 Alert Pop-Up

Press the **ENT** Key to display the TAWS Page, or press the **CLR** Key to remain on the Navigation Map Page.

TAWS Alerts Summary

The following table shows the possible TAWS alert types with corresponding annunciations and aural messages.

Alert Type	PFD/MFD TAWS Page Annunciation	MFD Pop-Up Alert	Aural Message
Excessive Descent Rate Warning (EDR)	PULL UP	PULL-UP	"Pull Up"
Reduced Required Terrain Clearance Warning (RTC)	PULL UP	TERRAIN - PULL-UP or TERRAIN AHEAD - PULL-UP	"Terrain, Terrain; Pull Up, Pull Up" or "Terrain Ahead, Pull Up; Terrain Ahead, Pull Up"
Imminent Terrain Impact Warning (ITI)	PULL UP	TERRAIN AHEAD - PULL-UP or TERRAIN - PULL-UP	Terrain Ahead, Pull Up; Terrain Ahead, Pull Up" or "Terrain, Terrain; Pull Up, Pull Up"
Reduced Required Obstacle Clearance Warning (ROC)	PULL UP	OBSTACLE - PULL-UP or OBSTACLE AHEAD - PULL-UP	"Obstacle, Obstacle; Pull Up, Pull Up" or "Obstacle Ahead, Pull Up; Obstacle Ahead, Pull Up"
Imminent Obstacle Impact Warning (IOI)	PULL UP	OBSTACLE AHEAD - PULL-UP or OBSTACLE - PULL-UP	"Obstacle Ahead, Pull Up; Obstacle Ahead, Pull Up" or "Obstacle, Obstacle; Pull Up, Pull Up"
Reduced Required Terrain Clearance Caution (RTC)	TERRAIN	CAUTION - TERRAIN or TERRAIN AHEAD	"Caution, Terrain; Caution, Terrain" or "Terrain Ahead; Terrain Ahead"
Imminent Terrain Impact Caution (ITI)	TERRAIN	TERRAIN AHEAD or CAUTION - TERRAIN	"Terrain Ahead; Terrain Ahead" or "Caution, Terrain; Caution, Terrain"
Reduced Required Obstacle Clearance Caution (ROC)	TERRAIN	CAUTION - OBSTACLE or OBSTACLE AHEAD	"Caution, Obstacle; Caution, Obstacle" or "Obstacle Ahead; Obstacle Ahead"
Imminent Obstacle Impact Caution (IOI)	TERRAIN	OBSTACLE AHEAD or CAUTION - OBSTACLE	"Obstacle Ahead; Obstacle Ahead" or "Caution, Obstacle; Caution, Obstacle"
Premature Descent Alert Caution (PDA)	TERRAIN	TOO LOW - TERRAIN	"Too Low, Terrain"
Altitude Callout "500"	None	None	"Five-Hundred"
Excessive Descent Rate Caution (EDR)	TERRAIN	SINK RATE	"Sink Rate"
Negative Climb Rate Caution (NCR)	TERRAIN	DON'T SINK or TOO LOW - TERRAIN	"Don't Sink" or "Too Low, Terrain"

SECTION 10 – HAZARD AVOIDANCE

The following system status annunciations may also be issued.

Alert Type	PFD/MFD TAWS Page Annunciation	MFD Pop-Up Alert	Aural Message
TAWS System Test Fail	TAWS FAIL	None	"TAWS System Failure"
TAWS Alerting is disabled	TAWS INHB	None	None
No GPS position or excessively degraded GPS signal	TAWS N/A	None	"TAWS Not Available" "TAWS Available" will be heard when sufficient GPS signal is re-established.
System Test in progress	TAWS TEST	None	None
System Test pass	None	None	"TAWS System Test OK"

Alert Annunciations

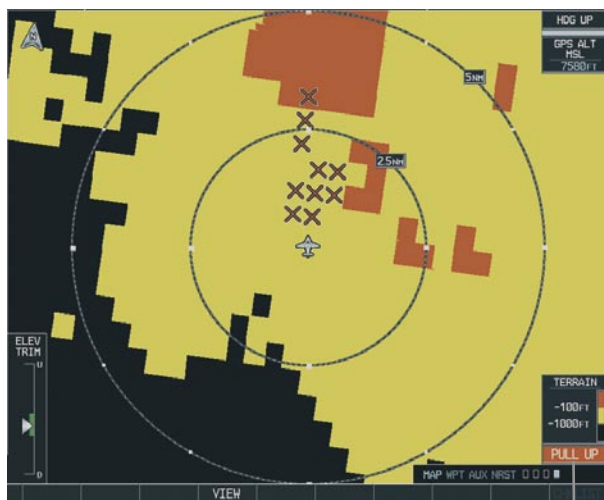

Alert Annuncia-

Figure 10-24 Alert Annunciation on the TAWS Page



Figure 10-25 Alert Annunciation on the PFD

SECTION 11: ABNORMAL OPERATION

11.1 REVERSIONARY MODE

Should a system detected failure occur in either display, the G1000 automatically enters reversionary mode. In reversionary mode, critical flight instrumentation is combined with engine instrumentation on the remaining display. Minimal navigation capability is available on the reversionary mode display.

Reversionary display mode can also be manually activated by the pilot if the system fails to detect a display problem. The reversionary mode is activated manually by pressing the red **DISPLAY BACKUP** button on the bottom of the audio panel (GMA 1347). Pressing the red **DISPLAY BACKUP** button again deactivates reversionary mode.



NOTE: *The Columbia 350/400 Airplane Flight Manual (AFM) always takes precedence over the information found in this section.*



Normal PFD Display



Normal MFD Display



MFD in Reversionary Mode

Figure 11-1 G1000 Reversionary Mode: Failed PFD

11.2 ABNORMAL COM OPERATION

When a COM tuning failure is detected by the system, the emergency frequency (121.500 MHz) is automatically loaded into the active frequency field of the COM radio for which the tuning failure was detected. In the event of a dual display failure, the emergency frequency (121.500 MHz) automatically becomes the active frequency to the pilot through the pilot headset.

11.3 UNUSUAL ATTITUDES

The PFD will ‘declutter’ when the aircraft enters an unusual attitude. Only the basic primary functions will be displayed in these situations.

Red extreme pitch warning chevrons pointing toward the horizon are displayed starting at 50 degrees above and 30 degrees below the horizon line.

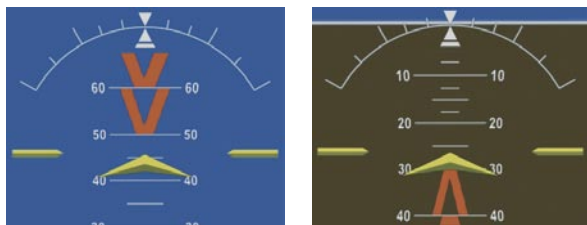

Figure 11-2 Extreme Pitch Indication

11.4 STORMSCOPE OPERATION WITH LOSS OF HEADING INPUT

If heading is lost, strikes and/or cells must be cleared manually after the execution of each turn. This is to ensure that the strike and/or cell positions are depicted accurately in relation to the nose of the aircraft.

11.5 HAZARD DISPLAYS WITH LOSS OF GPS POSITION

If GPS position is lost, or becomes invalid, selected hazards being displayed on the Navigation Map Page will be removed until GPS position is again established. The icons in the lower right of the screen, indicating the selected functions for display, will show an ‘X’, as shown in Figure 11-3.



Figure 11-3 Loss of Hazard Functions with Loss of GPS Position

SECTION 12: ANNUNCIATIONS & ALERTS



NOTE: The Airplane Flight Manual supersedes information found in this document.

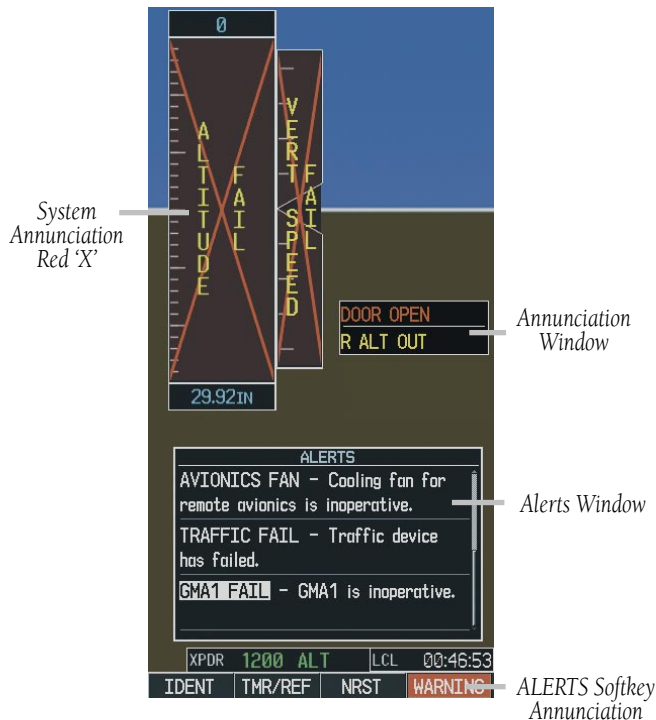

Figure 12-1 G1000 Alerting System

The G1000 Alerting System conveys alerts to the pilot using a combination of the following items:

- Annunciation Window:** The Annunciation Window displays abbreviated annunciation text. The Annunciation Window is located to the right of the Altitude and Vertical Speed Windows on the PFD display (or the MFD if system is in reversionary mode). Up to 12 annunciations can be displayed simultaneously. A white horizontal line separates annunciations that are acknowledged
- Alerts Window:** The Alerts Window displays alert text messages. Up to 64 prioritized alerts can be displayed in the Alerts Window. Selecting the **ALERTS** Softkey displays the Alerts Window. Selecting the **ALERTS** Softkey again removes the Alerts Window from the display. When the Alerts Window is displayed, the pilot may use the large **FMS** Knob to scroll through the alert list. Higher priority alerts are displayed at the top of the window. Lower priority alerts are displayed at the bottom of the window. Active alerts are displayed in white text. Alerts that have become inactive will change to gray text. The **ALERTS** Softkey will flash if the state of a displayed alert changes or a new alert is displayed. The inactive alerts can be removed from the Alerts Window by selecting the flashing **ALERTS** softkey.
- Alerts Softkey Annunciation:** When the Alerting System issues an alert, the **ALERTS** Softkey is used as a flashing annunciation to accompany an alert. During the alert, the **ALERTS** Softkey assumes a new label consistent with alert level (WARNING, CAUTION, or ADVISORY). Pressing the softkey annunciation acknowledges that the pilot is aware of the alert. The softkey then returns to the previous **ALERTS** label. The pilot can then select the **ALERTS** Softkey again to view alert text messages.
- System Annunciations:** Typically, a large red 'X' appears in a window when a related LRU fails or detects invalid data.

from annunciations that are not yet acknowledged. Acknowledged annunciations are always above the line. Annunciations are displayed in order of priority from top to bottom. The highest priority annunciation is displayed at the top of the Annunciation Window.

- **Audio Alerting System:** The G1000 system issues audio alert tones when specific system conditions are met. See the Alert Levels Definitions section for more information.

12.1 ALERT LEVEL DEFINITIONS

The G1000 Alerting System, as installed in Columbia 350/400 aircraft, uses three alert levels.

- **WARNING:** This level of alert requires immediate pilot attention. A warning alert is accompanied by an annunciation in the Annunciation Window. Warning text appearing in the Annunciation Window is RED. A warning alert is also accompanied by a flashing **WARNING** Softkey annunciation, as shown in Figure 12-2. Selecting the **WARNING** Softkey acknowledges the presence of the warning alert and stops the aural tone, if applicable.
- **CAUTION:** This level of alert indicates the existence of abnormal conditions on the aircraft that may require pilot intervention. A caution alert is accompanied by an annunciation in the Annunciation Window. Caution text appearing in the Annunciation Window is YELLOW. A caution alert is also accompanied by a flashing **CAUTION** Softkey annunciation, as shown in Figure 12-3. Selecting the **CAUTION** Softkey acknowledges the presence of the caution alert.
- **MESSAGE ADVISORY:** This level of alert provides general information to the pilot. A message advisory alert does not issue annunciations in the Annunciation Window. Instead, message advisory alerts only issue a flashing **ADVISORY** Softkey annunciation, as shown in Figure 12-4. Selecting the **ADVISORY** Softkey acknowledges the presence of the message advisory alert and displays the alert text message in the Alerts Window.



Figure 12-2 WARNING Softkey Annunciation



Figure 12-3 CAUTION Softkey Annunciation

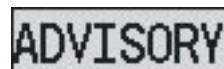

Figure 12-4 ADVISORY Softkey Annunciation

12.2 AIRCRAFT ALERTS

See the Airplane Flight Manual for information regarding pilot responses.

WARNING Alerts

Annunciation Window Text	Alerts Window Message	Audio Alert/Voice Message (Repeating)
DOOR OPEN	Door not secured	Chime/"Door Open"
FUEL VALVE	Fuel tank is not correctly selected or in OFF position	Chime/"Fuel Valve"
L BUS OFF	No power on the left bus	Chime
R BUS OFF	No power on the right bus	Chime
CO LVL HIGH	Carbon Monoxide level is too high	Chime/"Carbon Monoxide"
OIL PRES LOW	Low oil pressure	Chime/"Oil Pressure Low"

CAUTION Alerts

Annunciation Window Text	Alerts Window Message	Audio Alert/Voice Message
L ALT OFF	Left Alternator offline	Single Chime/"Left Alternator Out"
R ALT OFF	Right Alternator offline	Single Chime/"Right Alternator Out"
FUEL PUMP	Fuel pump is operating	Single Chime/"Fuel Pump On"
L-LOW FUEL	Low fuel in the left tank	Single Chime/None
R LOW FUEL	Low fuel in the right tank	Single Chime/None
RUDR LMTR *	Rudder limiter is engaged	Single Chime/None
STARTER ENGD	Starter relay has power applied	Single Chime/None
OXYGEN	Oxygen system needs attention or is off	Single Chime/None
OXYGEN QTY	Oxygen quantity below 250 psi.	Single Chime/None
OXYGEN PRES	Pressure above 12000 ft and oxygen system off.	Single Chime/None

* Columbia 350 only

Annunciation Advisory

Annunciation Window Text	Alerts Window Message	Audio Alert
OXYGEN ON	Reminder: Turn off oxygen	None
SPEED BRAKES	Speed brakes are active	None

Message Advisory Alerts

Alerts Window Message	Audio Alert
PFD FAN FAIL – The cooling fan for the PFD is inoperative.	None
MFD FAN FAIL – The cooling fan for the MFD is inoperative.	None
AVIONICS FAN – The cooling fan for remote avionics is inoperative.	None
TIMER ZERO – Timer has counted down to zero.	“Timer Expired”
FUEL IMBAL – Fuel imbalance is greater than 10 gallons.	None
LOW MAN PRES – Manifold pressure is below 15 in.	None
VAPOR SUPPR – Turn on Vapor Suppression.*	None

* Columbia 400 only

12.3 CO GUARDIAN MESSAGES

Alerts Window Message	Comments
CO DET SRVC – The carbon monoxide detector needs service.	There is a problem within the CO Guardian that requires services.
CO DET FAIL – The carbon monoxide detector is inoperative.	Loss of communication between the G1000 and the CO Guardian.

12.4 AFCS ALERTS

System Status Annunciation

The following alert annunciations appear in the AFCS System Status Annunciation on the PFD.

System Status Annunciation



Figure 12-5 AFCS System Status Annunciation





Condition	Annunciation	Description
Pitch Failure	PTCH	Pitch axis control failure. AP is inoperative.
Roll Failure	ROLL	Roll axis control failure. AP is inoperative.
MET Switch Stuck, or Pitch Trim Axis Control Failure	PTRM	If annunciated when AP is engaged, take control of the aircraft and disengage the autopilot. If annunciated when AP is not engaged, move each half of the MET switch separately to check if a stuck switch is causing the annunciation.
System Failure	AFCS	AP and MET are unavailable. FD may still be available.
Elevator Mistrim Up	↑ELE	A condition has developed causing the pitch servo to provide a sustained force. Be prepared to apply nose up control wheel force upon autopilot disconnect.
Elevator Mistrim Down	↓ELE	A condition has developed causing the pitch servo to provide a sustained force. Be prepared to apply nose down control wheel force upon autopilot disconnect.
Aileron Mistrim Left	←AIL	A condition has developed causing the roll servo to provide a sustained left force. Ensure the slip/skid indicator is centered and observe any maximum fuel imbalance limits.
Aileron Mistrim Right	AIL→	A condition has developed causing the roll servo to provide a sustained right force. Ensure the slip/skid indicator is centered and observe any maximum fuel imbalance limits.
Preflight Test	PFT	Performing preflight system test. Upon completion of the test, the aural alert will be heard.
	PFT	Preflight system test has failed.

12.5 TAWS ALERTS

Annunciations appear on the PFD and MFD. Pop-up alerts appear only on the MFD.

Alert Type	PFD/MFD TAWS Page Annunciation	MFD Map Page Pop-Up Alert	Aural Message
Excessive Descent Rate Warning (EDR)			"Pull Up"
Reduced Required Terrain Clearance Warning (RTC)		 or 	"Terrain, Terrain; Pull Up, Pull Up" or "Terrain Ahead, Pull Up; Terrain Ahead, Pull Up"
Imminent Terrain Impact Warning (ITI)		 or 	Terrain Ahead, Pull Up; Terrain Ahead, Pull Up" or "Terrain, Terrain; Pull Up, Pull Up"
Reduced Required Obstacle Clearance Warning (ROC)		 or 	"Obstacle, Obstacle; Pull Up, Pull Up" or "Obstacle Ahead, Pull Up; Obstacle Ahead, Pull Up"
Imminent Obstacle Impact Warning (IOI)		 or 	"Obstacle Ahead, Pull Up; Obstacle Ahead, Pull Up" or "Obstacle, Obstacle; Pull Up, Pull Up"
Reduced Required Terrain Clearance Caution (RTC)		 or 	"Caution, Terrain; Caution, Terrain" or "Terrain Ahead; Terrain Ahead"
Imminent Terrain Impact Caution (ITI)		 or 	"Terrain Ahead; Terrain Ahead" or "Caution, Terrain; Caution, Terrain"
Reduced Required Obstacle Clearance Caution (ROC)		 or 	"Caution, Obstacle; Caution, Obstacle" or "Obstacle Ahead; Obstacle Ahead"
Imminent Obstacle Impact Caution (IOI)		 or 	"Obstacle Ahead; Obstacle Ahead" or "Caution, Obstacle; Caution, Obstacle"
Premature Descent Alert Caution (PDA)			"Too Low, Terrain"
Altitude Callout "500"	None	None	"Five-Hundred"
Excessive Descent Rate Caution (EDR)			"Sink Rate"
Negative Climb Rate Caution (NCR)		 or 	"Don't Sink" or "Too Low, Terrain"

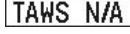
TAWS System Status Annunciations

Alert Type	PFD/MFD TAWS Page Annunciation	MFD Pop-Up Alert	Aural Message
TAWS System Test Fail		None	"TAWS System Failure"
TAWS Alerting is disabled		None	None
No GPS position or excessively degraded GPS signal		None	"TAWS Not Available" "TAWS Available" will be heard when sufficient GPS signal is re-established.
System Test in progress		None	None
System Test pass	None	None	"TAWS System Test OK"

12.6 G1000 SYSTEM ANNUNCIATIONS







When an LRU or an LRU function fails, a large red 'X' is typically displayed on windows associated with the failed data. The following section describes various system annunciations. Refer to the AFM for additional information regarding pilot responses to these annunciations.



NOTE: Upon power-up of the G1000 system, certain windows remain invalid as G1000 equipment begins to initialize. All windows should be operational within one minute of power-up. Should any window continue to remain flagged, the G1000 system should be serviced by a Garmin-authorized repair facility.

System Annunciation	Comment
	Attitude and Heading Reference System is aligning.

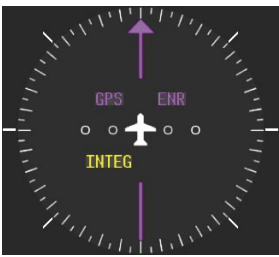
SECTION 12 – ANNUNCIATIONS & ALERTS

System Annunciation	Comment
	<p>Display system is not receiving attitude information from the AHRS.</p>
	<p>Display system is not receiving airspeed input from air data computer.</p>
	<p>Display is not receiving altitude input from the air data computer.</p>
	<p>Display is not receiving vertical speed input from the air data computer.</p>
	<p>Display is not receiving valid heading input from AHRS.</p>
	<p>GPS information is either not present or is invalid for navigation use. Note that AHRS utilizes GPS inputs during normal operation. AHRS operation may be degraded if GPS signals are not present (see AFM).</p>
	<p>Display is not receiving valid transponder information.</p>
<p>Other Various Red X Indications</p>	<p>A red 'X' through any other display field, such as engine instrumentation fields, indicates that the field is not receiving valid data.</p>

A red 'X' may be the result of an LRU or an LRU function failure. The Figure 12-6 illustrates all possible flags and the responsible LRUs.

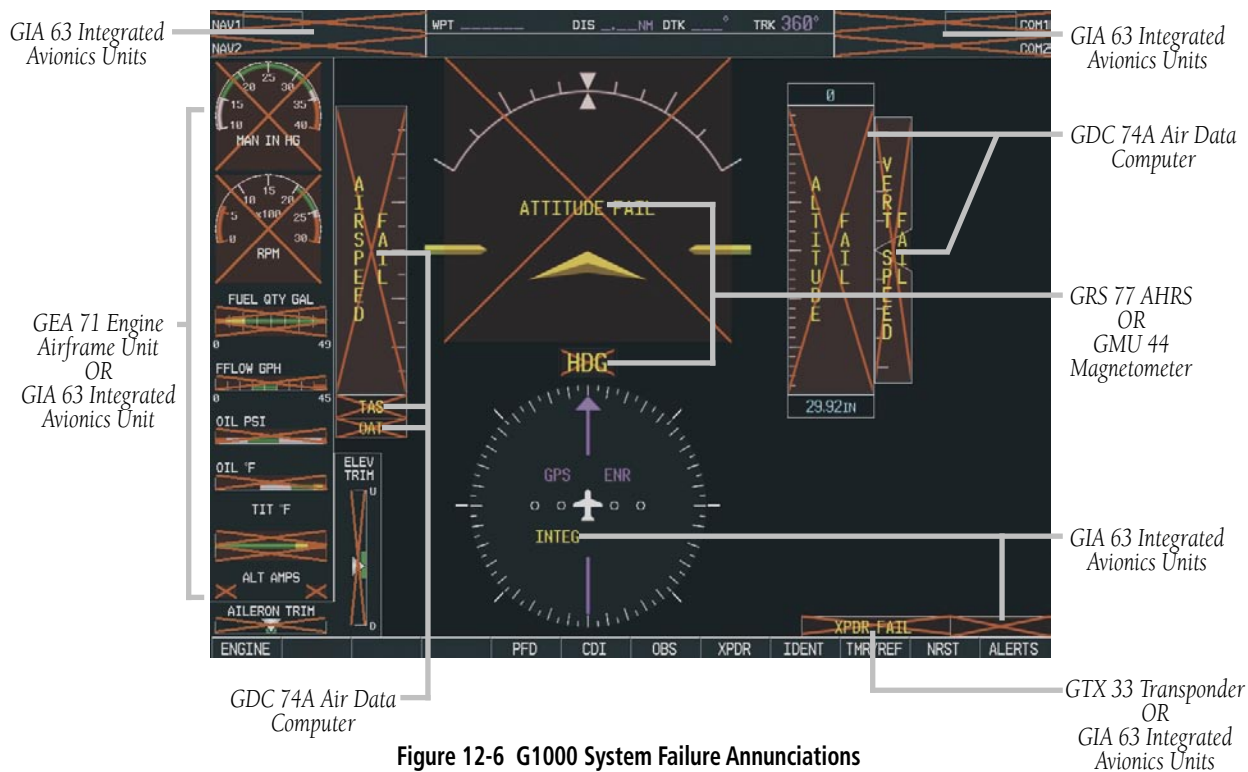

Figure 12-6 G1000 System Failure Annunciations

12.7 G1000 SYSTEM MESSAGE ADVISORIES

This section describes various G1000 system message advisories. Certain messages are issued due to an LRU or an LRU function failure. Such messages are normally accompanied by a corresponding red 'X' annunciation as shown previously in the G1000 System Annunciation section.



NOTE: This section provides information regarding G1000 message advisories that may be displayed by the system. Knowledge of the aircraft, systems, flight conditions, and other existing operational priorities must be considered when responding to a message. Always use sound pilot judgment. The Columbia 350/400 Airplane Flight Manual (AFM) takes precedence over any conflicting guidance found in this section.

MFD & PFD Message Advisories

Message	Comments
DATA LOST – Pilot stored data was lost. Recheck settings.	The pilot profile data was lost. System reverts to default pilot profile and settings. The pilot may reconfigure the MFD & PFD with preferred settings, if desired.
XTALK ERROR – A flight display crosstalk error has occurred.	The MFD and PFD are not communicating with each other. The G1000 system should be serviced.
PFD1 SERVICE – PFD1 needs service. Return unit for repair.	The PFD and/or MFD self-test has detected a problem. The G1000 system should be serviced.
MFD1 SERVICE – MFD1 needs service. Return unit for repair.	
PFD1 CONFIG – PFD1 configuration error. Config service req'd.	The PFD and/or MFD configuration settings do not match backup configuration memory. The G1000 system should be serviced.
MFD1 CONFIG – MFD1 configuration error. Config service req'd.	
SW MISMATCH – GDU software mismatch. Xtalk is off.	The MFD and PFD have different software versions installed. The G1000 system should be serviced.
MANIFEST – PFD1 software mismatch. Communication halted.	The PFD and/or MFD has incorrect software installed. The G1000 system should be serviced.
MANIFEST – MFD1 software mismatch. Communication halted.	
PFD1 COOLING – PFD1 has poor cooling. Reducing power usage.	The PFD and/or MFD is overheating and is reducing power consumption by dimming the display. If problem persists, the G1000 system should be serviced.
MFD1 COOLING – MFD1 has poor cooling. Reducing power usage.	
PFD1 "KEY" KEYSTK – Key is stuck.	A key is stuck on the PFD and/or MFD bezel. Attempt to free the stuck key by pressing it several times. The G1000 system should be serviced if the problem persists.
MFD1 "KEY" KEYSTK – Key is stuck.	
CNFG MODULE – PFD1 configuration module is inoperative.	The PFD configuration module backup memory has failed. The G1000 system should be serviced.
PFD1 VOLTAGE – PFD1 has low voltage. Reducing power usage.	The PFD1 voltage is low. The G1000 system should be serviced.
MFD1 VOLTAGE – MFD1 has low voltage. Reducing power usage.	The MFD1 voltage is low. The G1000 system should be serviced.

Database Message Advisories

Alerts Window Message	Comments
MFD1 DB ERR – MFD1 aviation database error exists.	The MFD and/or PFD detected a failure in the aviation database. Attempt to reload the aviation database. If problem persists, the G1000 system should be serviced.
PFD1 DB ERR – PFD1 aviation database error exists.	
MFD1 DB ERR – MFD1 basemap database error exists.	The MFD and/or PFD detected a failure in the basemap database.
PFD1 DB ERR – PFD1 basemap database error exists.	
MFD1 DB ERR – MFD1 terrain database error exists.	The MFD and/or PFD detected a failure in the terrain database. Ensure that the terrain card is properly inserted in display. Replace terrain card. If problem persists, The G1000 system should be serviced.
PFD1 DB ERR – PFD1 terrain database error exists.	
MFD1 DB ERR – MFD1 obstacle database error exists.	The MFD and/or PFD detected a failure in the obstacle database. Ensure that the data card is properly inserted. Replace data card. If problem persists, The G1000 system should be serviced.
PFD1 DB ERR – PFD1 obstacle database error exists.	
MFD1 DB ERR – MFD1 airport terrain database error exists.	The MFD and/or PFD detected a failure in the airport terrain database. Ensure that the data card is properly inserted. Replace data card. If problem persists, The G1000 system should be serviced.
PFD1 DB ERR – PFD1 airport terrain database error exists.	
DB MISMATCH – Aviation database version mismatch. Xtalk is off.	The PFD and MFD have different aviation database versions installed. Crossfill is off. Install correct aviation database version in both displays.
DB MISMATCH – Aviation database type mismatch. Xtalk is off.	The PFD and MFD have different aviation database types installed (Americas, European, etc.). Crossfill is off. Install correct aviation database type in both displays.
DB MISMATCH – Basemap database version mismatch. Xtalk is off.	The PFD and MFD have different basemap database versions installed. Crossfill is off. Install correct basemap database version in both displays.
DB MISMATCH – Terrain database version mismatch. Xtalk is off.	The PFD and MFD have different terrain database versions installed. Crossfill is off. Install correct terrain database version in both displays.
DB MISMATCH – Terrain database type mismatch. Xtalk is off.	The PFD and MFD have different terrain database types installed. Crossfill is off. Install correct terrain database type in both displays.
DB MISMATCH – Obstacle database version mismatch. Xtalk is off.	The PFD and MFD have different obstacle database versions installed. Crossfill is off. Install correct obstacle database version in both displays.

Database Message Advisories (Cont.)

Alerts Window Message	Comments
DB MISMATCH – Airport Terrain database mismatch. Xtalk is off	The PFD and MFD have different airport terrain databases installed. Crossfill is off. Install correct airport terrain database in both displays.

GMA 1347 Message Advisories

Alerts Window Message	Comments
GMA1 FAIL – GMA1 is inoperative.	The audio panel self-test has detected a failure. The audio panel is unavailable. The G1000 system should be serviced.
GMA1 CONFIG – GMA1 configuration error. Config service req'd.	The audio panel configuration settings do not match backup configuration memory. The G1000 system should be serviced.
MANIFEST – GMA1 software mismatch. Communication halted.	The audio panel has incorrect software installed. The G1000 system should be serviced.
GMA1 SERVICE – GMA1 needs service. Return unit for repair.	The audio panel self-test has detected a problem in the unit. Certain audio functions may still be available, and the audio panel may still be usable. The G1000 system should be serviced when possible.
BACKUP PATH – Audio panel 1 using backup data path.	The #1 audio panel is using a backup communication path. The G1000 system should be serviced when possible.

GIA 63 Message Advisories

Alerts Window Message	Comments
GIA1 CONFIG – GIA1 configuration error. Config service req'd.	The GIA1 and/or GIA2 configuration settings do not match backup configuration memory. The G1000 system should be serviced.
GIA2 CONFIG – GIA2 configuration error. Config service req'd.	
GIA1 COOLING – GIA1 temperature too low.	The GIA1 and/or GIA2 temperature is too low to operate correctly. Allow units to warm up to operating temperature.
GIA2 COOLING – GIA2 temperature too low.	
GIA1 COOLING – GIA1 over temperature.	The GIA1 and/or GIA2 temperature is too high. If problem persists, the G1000 system should be serviced.
GIA2 COOLING – GIA2 over temperature.	

GIA 63 Message Advisories (Cont.)

Alerts Window Message	Comments
GIA1 SERVICE – GIA1 needs service. Return the unit for repair.	The GIA1 and/or GIA2 self-test has detected a problem in the unit. The G1000 system should be serviced.
GIA2 SERVICE – GIA2 needs service. Return the unit for repair.	
HW MISMATCH – GIA hardware mismatch. Communication halted.	There is a hardware mismatch between GIA1 and GIA2. The G1000 system should be serviced.
MANIFEST – GIA1 software mismatch. Communication halted.	The GIA1 and/or GIA 2 has incorrect software installed. The G1000 system should be serviced.
MANIFEST – GIA2 software mismatch. Communication halted.	
COM1 TEMP – COM1 over temp. Reducing transmitter power.	The system has detected an over temperature condition in COM1 and/or COM2. The transmitter will operate at reduced power. If the problem persists, the G1000 system should be serviced.
COM2 TEMP – COM2 over temp. Reducing transmitter power.	
COM1 SERVICE – COM1 needs service. Return unit for repair.	The system has detected a failure in COM1 and/or COM2. COM1 and/or COM2 may still be usable. The G1000 system should be serviced when possible.
COM2 SERVICE – COM2 needs service. Return unit for repair.	
COM1 PTT – COM1 push-to-talk key is stuck.	The COM1 and/or COM2 external push-to-talk switch is stuck in the enable (or "pressed") position. Press the PTT switch again to cycle its operation. If the problem persists, the G1000 system should be serviced.
COM2 PTT – COM2 push-to-talk key is stuck.	
COM1 RMT XFR – COM1 remote transfer key is stuck.	The COM1 and/or COM2 transfer switch is stuck in the enabled (or "pressed") position. Press the transfer switch again to cycle its operation. If the problem persists, the G1000 system should be serviced.
COM2 RMT XFR – COM2 remote transfer key is stuck.	
RAIM UNAVAIL – RAIM is not available from FAF to MAP waypoints.	GPS satellite coverage is insufficient to perform Receiver Autonomous Integrity Monitoring (RAIM) from the FAF to the MAP waypoints.
RAIM UNAVAIL – RAIM is not available.	GPS satellite coverage is insufficient to perform Receiver Autonomous Integrity Monitoring (RAIM) for the current phase of flight.
POSN ERROR – RAIM has determined GPS position is in error.	When a RAIM position error is detected, GPS is flagged and the system no longer provides GPS-based guidance.

GIA 63 Message Advisories (Cont.)

Alerts Window Message	Comments
DGRD GPS ACC – GPS position accuracy degraded & RAIM unavailable.	GPS position accuracy has been degraded and RAIM is not available.
GPS1 FAIL – GPS1 is inoperative.	A failure has been detected in the GPS1 and/or GPS2 receiver. The receiver is unavailable. The G1000 system should be serviced.
GPS2 FAIL – GPS2 is inoperative.	
GPS1 SERVICE – GPS1 needs service. Return unit for repair.	A failure has been detected in the GPS1 and/or GPS2 receiver. The receiver may still be available. The G1000 system should be serviced.
GPS2 SERVICE – GPS2 needs service. Return unit for repair.	
NAV1 SERVICE – NAV1 needs service. Return unit for repair.	A failure has been detected in the NAV1 and/or NAV2 receiver. The receiver may still be available. The G1000 system should be serviced.
NAV2 SERVICE – NAV2 needs service. Return unit for repair.	
NAV1 RMT XFR – NAV1 remote transfer key is stuck.	The remote NAV1 and/or NAV2 transfer switch is stuck in the enabled (or “pressed”) state. Press the transfer switch again to cycle its operation. If the problem persists, the G1000 system should be serviced.
NAV2 RMT XFR – NAV2 remote transfer key is stuck.	
G/S1 FAIL – G/S1 is inoperative.	A failure has been detected in glideslope receiver 1 and/or receiver 2. The G1000 system should be serviced.
G/S2 FAIL – G/S2 is inoperative.	
G/S1 SERVICE – G/S1 needs service. Return unit for repair.	A failure has been detected in glideslope receiver 1 and/or receiver 2. The receiver may still be available. The G1000 system should be serviced when possible.
G/S2 SERVICE – G/S2 needs service. Return unit for repair.	

GEA 71 Message Advisories

Alerts Window Message	Comments
GEA1 CONFIG – GEA1 configuration error. Config service req'd.	The GEA 71 configuration settings do not match those of backup configuration memory. The G1000 system should be serviced.
MANIFEST – GEA1 software mismatch. Communication halted.	The GEA 71 has incorrect software installed. The G1000 system should be serviced.
BACKUP PATH – EIS using backup data path.	The GEA 71 is using a backup communication path. The G1000 system should be serviced when possible.

GTX 33 Message Advisories

Alerts Window Message	Comments
XPDR1 CONFIG – XPDR1 config error. Config service req'd.	The transponder configuration settings do not match those of backup configuration memory. The G1000 system should be serviced.
MANIFEST – GTX1 software mismatch. Communication halted.	The transponder has incorrect software installed. The G1000 system should be serviced.
BACKUP PATH – XPDR1 using backup data path.	The #1 transponder is using a backup communications path. The G1000 system should be serviced when possible.

GRS 77 Message Advisories

Alerts Window Message	Comments
AHRS1 TAS – AHRS1 not receiving airspeed.	The #1 AHRS is not receiving true airspeed from the air data computer. The AHRS relies on GPS information to augment the lack of airspeed. The G1000 system should be serviced.
AHRS1 GPS – AHRS1 using backup GPS source.	The #1 AHRS is using the backup GPS path. Primary GPS path has failed. The G1000 system should be serviced when possible.
AHRS1 GPS – AHRS1 not receiving any GPS information.	The #1 AHRS is not receiving any or any useful GPS information. Check AFMS limitations. The G1000 system should be serviced.
AHRS1 GPS – AHRS1 not receiving backup GPS information.	The #1 AHRS is not receiving backup GPS information. The G1000 system should be serviced.
AHRS1 GPS – AHRS1 operating exclusively in no-GPS mode.	The #1 AHRS is operating exclusively in no-GPS mode. The G1000 system should be serviced.
MANIFEST – GRS1 software mismatch. Communication halted.	The AHRS has incorrect software installed. The G1000 system should be serviced.
BACKUP PATH – AHRS1 using backup data path.	The #1 AHRS is using a backup communications data path. The G1000 system should be serviced when possible.
AHRS1 SRVC – AHRS1 Magnetic-field model needs update.	The #1 AHRS earth magnetic field model is out of date. Update magnetic field model when practical.
GEO LIMITS – AHRS1 too far North/South, no magnetic compass.	The aircraft is outside geographical limits for approved AHRS operation. Heading is flagged as invalid.

GMU 44 Message Advisories

Alerts Window Message	Comments
HDG FAULT – AHRS1 magnetometer fault has occurred.	A fault has occurred in the GMU 44. Heading is flagged as invalid. The AHRS uses GPS for backup mode operation. The G1000 system should be serviced.
MANIFEST – GMU1 software mismatch. Communication halted.	The GMU 44 has incorrect software installed. The G1000 system should be serviced.

GDL 69 Message Advisories

Alerts Window Message	Comments
GDL69 CONFIG – GDL 69 configuration error. Config service req'd.	GDL 69 configuration settings do not match those of backup configuration memory. The G1000 system should be serviced.
GDL69 FAIL – GDL 69 has failed.	A failure has been detected in the GDL 69. The receiver is unavailable. The G1000 system should be serviced

GDC 74A Message Advisories

Alerts Window Message	Comments
GDC1 CONFIG – GDC1 configuration error. Config service req'd.	GDC 74A configuration settings do not match those of backup configuration memory. The G1000 system should be serviced.
MANIFEST – GDC1 software mismatch. Communication halted.	The GDC 74A has incorrect software installed. The G1000 system should be serviced.
BACKUP PATH – ADC1 using backup data path.	The GDC 74A is using a backup communications data path. The G1000 system should be serviced when possible.

GCU 476 Message Advisories

Alerts Window Message	Comments
GCU CNFG – GCU Config error. Config service req'd.	GCU 476 configuration settings do not match those of backup configuration memory. The G1000 system should be serviced.
GCU FAIL – GCU is inoperative.	The GCU 476 has failed. The G1000 system should be serviced when possible.
GCU PATH – A GCU path has failed.	The GCU 476 is using a backup communications data path. The G1000 system should be serviced when possible.

Miscellaneous Message Advisories

Alerts Window Message	Comments
FPL WPT LOCK – Flight plan waypoint is locked.	Upon power-up, the G1000 system detects that a stored flight plan waypoint is locked. This occurs when an aviation database update eliminates an obsolete waypoint. The flight plan cannot find the specified waypoint and flags this message. This can also occur with user waypoints in a flight plan that is deleted. Remove the waypoint from the flight plan if it no longer exists in any database, OR update the waypoint name/identifier to reflect the new information.
FPL WPT MOVE – Flight plan waypoint moved.	The system has detected that a waypoint coordinate has changed due to a new aviation database update. Verify that stored flight plans contain correct waypoint locations.
TIMER EXPIRD – Timer has expired.	The system notifies the pilot that the timer has expired.
DB CHANGE – Database changed. Verify user modified procedures.	This occurs when a stored flight plan contains procedures that have been manually edited. This alert is issued only after an aviation database update. Verify that the user-modified procedures in stored flight plans are correct and up to date.
FPL TRUNC – Flight plan has been truncated.	This occurs when a newly installed aviation database eliminates an obsolete approach or arrival used by a stored flight plan. The obsolete procedure is removed from the flight plan. Update flight plan with current arrival or approach.
APPR VPROF – Approaching VNAV profile.	Aircraft is approaching VNAV profile. Prepare to climb or descend to meet VNAV profile.
APPR TRG ALT – Approaching target altitude.	Aircraft is approaching target altitude. Prepare to level aircraft.
LOCKED FPL – Cannot navigate locked flight plan.	This occurs when the pilot attempts to activate a stored flight plan that contains locked waypoint. Remove locked waypoint from flight plan. Update flight plan with current waypoint.
WPT ARRIVAL – Arriving at waypoint -[xxxx]	Arriving at waypoint [xxxx], where [xxxx] is the waypoint name.
STEEP TURN – Steep turn ahead.	A steep turn is 15 seconds ahead. Prepare to turn.
INSIDE ARSPC – Inside airspace.	The aircraft is inside the airspace. Note that depending on the buffer value that is selected and GPS altitude being used for calculation, the actual aircraft position in space may differ from the calculated position. This can result in an erroneous alert.
ARSPC AHEAD – Airspace ahead less than 10 minutes.	Special use airspace is ahead of aircraft. The aircraft will penetrate the airspace within 10 minutes.

Miscellaneous Message Advisories (Cont.)

Alerts Window Message	Comments
ARSPC NEAR – Airspace near and ahead.	Special use airspace is near and ahead of the aircraft position.
ARSPC NEAR – Airspace near – less than 2 nm.	Special use airspace is within 2 nm of the aircraft position.
LEG UNSMOOTH – Flight plan leg will not be smooth.	The approaching flight plan waypoints are too close to allow for smooth turns. Prepare for steep turns ahead and expect noticeable course deviations.
APPR INACTV – Approach is not active.	The system notifies the pilot that the loaded approach is not active. Activate approach when required.
SLCT AUTOSEQ – Select auto sequence mode.	The system notifies the pilot to select auto-sequence mode. Press the OBS Softkey to deactivate the OBS mode.
SLCT FREQ – Select appropriate frequency for approach.	The system notifies the pilot to load the approach frequency for the appropriate NAV receiver. Select the correct frequency for the approach.
SLCT NAV – Select NAV on CDI for approach.	The system notifies the pilot to set the CDI to the correct NAV receiver. Set the CDI to the correct NAV receiver.
NO WGS84 WPT – Non WGS 84 waypoint for navigation -[xxxx]	The selected waypoint [xxxx] does not use the WGS 84 datum. Cross-check position with alternate navigation sources.
TRAFFIC FAIL – Traffic device has failed.	The G1000 is no longer receiving data from the traffic system. The traffic device should be serviced.
STRMSCP FAIL – Stormscope has failed.	Stormscope has failed. The Stormscope system should be serviced.
BACKUP PATH – Stormscope using backup path.	Stormscope is using the backup communication path. The G1000 system should be serviced when possible.

A

Abnormal COM operation 11-2
 Activate a flight plan 8-3
 Active flight plan 8-2
 ADVISORY 12-1
 Advisory alerts 12-4
 AFCS 1-3, 6-1, 6-2, 6-4, 6-6, 6-7, 6-9,
 6-11, 6-12, 6-13, 12-5
 Age 10-6
 AHRS 12-15, 12-16
 Aircraft alerts 12-3
 AIRMET 10-5
 Airport frequency 7-6
 Airport information 7-3
 Airspace alerts 7-9
 Airspeed indicator 2-3
 Airspeed trend vector 2-3
 Alerting System 12-1
 Alerts 12-1
 Alert levels 12-2
 Alert Pop-Up 10-14
 Altitude alerting 2-4
 Altitude Hold 1-4
 Altitude hold 1-4, 6-3 – 6-8, 6-10
 Altitude trend vector 2-4
 ALT knob 1-4
 Annunciations 12-1
 AP 1-4, 1-5, 6-1 – 6-7, 6-9, 12-5
 Approaches 9-2
 Approach activation 4-3
 Approach markers
 Signal augmentation 5-3
 Approach Mode 6-12
 AP disconnect 6-1
 Arc HSI 2-6
 Arrivals 9-1
 Attitude indicator 2-3
 Audio alerting system 12-2
 Audio panel 4-3, 5-1
 Audio panel controls
 COM 1/2 5-2
 Auto-tuning 4-3
 Automatic squelch 4-3

Autopilot 6-1, 6-2, 6-3, 6-5 – 6-10,
 6-12, 6-13, 12-5
 Aviation database 1-11

B

Backcourse 6-11
 Barometric setting 2-4
 Base reflectivity 10-4
 BKSP softkey 4-4
 BRG1 2-7
 BRG2 2-7

C

Carbon monoxide 3-2
 Caution 12-1, 12-2
 CDI 2-8, 12-18
 Cell 10-2
 Cell mode 10-2
 Cell movement 10-5
 Cloud tops 10-4
 CLR key 1-3, 1-5
 Coast mode 10-7
 Codes (important) 4-4
 Code selection 4-4
 CODE softkey 4-4
 COM Frequency Window 4-1
 COM knob 4-3
 Controls 1-2, 4-1
 Control Wheel Steering 6-1, 6-3
 Create a new flight plan 8-4
 Create a new user waypoint 8-1
 CWS 6-1, 6-3 – 6-9
 Cyclones 10-5

D

Departures 9-1
 Direct-to 7-1
 Dual CDU failure 11-2

E

ECHO TOPS 10-4
 Edit a flight plan 8-5

EDR 10-13
 Emergency code 4-4
 Endurance 3-6
 Excessive Descent Rate 10-13

F

FD 1-4, 1-5, 12-5
 Five-Hundred Aural Alert 10-13
 FLC 1-4, 6-3, 6-7
 Flight director 6-1 – 6-4, 6-6 – 6-10
 Flight level change 1-4, 6-3, 6-7, 6-11,
 6-16
 Flight Plan Catalog 9-1, 9-2
 FLTA 10-12
 Forward Looking Terrain Avoidance
 10-12
 FPL key 1-3, 1-5
 Freezing level 10-5
 Frequency toggle key 1-3, 4-3
 Fuel remaining 3-6
 Fuel used 3-6

G

GA 6-1, 6-3, 6-8, 6-9, 6-12
 Glideslope 2-2, 2-5, 6-3, 6-8, 6-9,
 6-12
 GMA 1347 1-1
 Go Around 6-1, 6-3, 6-8, 6-9, 6-12,
 6-19

H

HDG key 6-10
 Heading hold 6-9
 Heading indication 2-7
 Heading Select 1-3, 1-4, 6-9, 6-10
 Heading Select Mode 6-10
 Headset(s) 5-3
 Hijack code 4-4
 Horizontal situation indicator 2-6
 Hurricanes 10-5

I

ICAO 4-4
 ID 4-3
 Imminent Terrain Impact 10-12
 Impact point 10-12
 Inhibit 10-12
 Inhibit TAWS 10-12
 INTEG 2-8
 Interrogations 4-4
 IOI 10-12, 10-15, 12-6
 ITI 10-12

K

Key(s) 1-4, 1-5

L

Lighted obstacle 10-14
 Lightning 1-6, 1-9, 10-2, 10-3, 10-4
 Load approach 8-5
 Load a VOR frequency 7-8
 Load departure 8-5
 Load the frequency for a controlling agency 7-10
 Load the nearest ARTCC frequency 7-9
 Loss of communication code 4-4

M

Manual Electric Trim 6-1
 MAP 7-1
 Map panning 10-5
 Marker beacon 2-5
 messages 12-1
 Message advisories 12-2, 12-10
 – 12-18
 MET 6-1, 6-3, 12-5
 METAR 10-3, 10-5
 MFD 1-1, 4-3
 Military interceptor operations code 4-4
 Missed Approach 6-19
 Mistrim 12-5
 Mixture 3-3, 3-4, 3-5

MKR/MUTE 5-2, 5-3, 5-4
 Mode selection softkeys 4-4
 Morse code identifier 4-3

N

Nav/Com controls 4-1
 NAV1 5-3
 NAV2 5-3
 Navigation 7-1
 Navigation Mode 6-11
 Navigation status window 2-2
 NAV Frequency Window 4-1
 NCR 10-13
 Nearest Airports Page 7-3, 7-5, 7-7,
 7-8, 7-9, 8-1
 Nearest ARTCC & FSS frequencies 7-9
 Negative Climb Rate After Takeoff
 10-13
 NEXRAD 1-6, 1-9, 10-3 – 10-6

O

OBS 2-8
 Obstacles 10-14, 12-11, 12-12, 12-13
 Operation 5-2
 overspeed 6-2
 Oxygen 3-2

P

Page group icon 1-10
 PDA 10-12
 PFD 1-1, 4-1, 4-3
 PIT 6-3
 pitch axis modes 6-3
 Pitch hold 1-4, 6-1, 6-3, 6-4, 6-8
 PLAY key 5-4
 Premature Descent Alert 10-12
 PROC key 1-3, 1-5

R

Red pointer 2-3
 Remove departure, arrival, or approach
 8-5

Replies 4-4
 Reversionary mode 11-1
 ROC 10-12, 10-15, 12-6
 Roll Axis Modes 6-2, 6-9
 Roll Hold 6-9
 RTC 10-12
 RX indicator 4-3
 R indication 4-4

S

Selected vertical speed 2-5
 Severe thunderstorm 10-5
 SIGMET 10-5
 Slip/Skid indicator 2-3
 Softkey function (MFD) 1-6, 1-9
 Speed ranges 2-3
 Split COM 5-2
 Squelch 5-4
 Store Flight Plan 8-5
 Stormscope lightning data 1-6, 1-9,
 10-2, 10-3
 Strike 10-2
 Strike mode 10-2
 System annunciations 12-1, 12-7
 System message advisories 12-9

T

TA 10-7
 TAF 10-3
 TAS 10-8, 10-9, 12-15
 TAWS 10-10, 10-11, 10-12, 10-14,
 10-15, 10-16, 12-6, 12-7
 TAWS-B 10-10
 TAWS system test 10-12
 Terrain 10-9, 10-10, 10-14, 10-16,
 11-2, 12-11
 Terrain proximity 10-9
 TIT 3-5
 Tornado 10-5
 Traffic advisory 10-7, 10-8, 10-9,
 10-16
 Traffic map page 10-7 – 10-9, 10-14
 Transponder 4-4

Transponder Status bar 4-4
 Trim 3-2, 6-1
 Tropical storms 10-5
 TX 4-3

U

Unlighted obstacle 10-14
 Usable fuel 3-6

V

Vertical Deviation/Glideslope indicator 2-5
 Vertical navigation profile 8-8
 Vertical speed 1-4, 2-1, 2-5, 6-3, 6-6, 12-1
 Vertical Speed Bug 2-5
 Vertical Speed Mode 6-6
 VFR code 4-4
 VHF 4-1
 VOL/PUSH ID 4-2
 VOL/PUSH SQ 4-2, 4-3
 Volume/squelch 5-4
 VS 1-4, 6-3, 6-6
 Vspeeds 2-3

W

WARN 2-8
 Warning 12-1, 12-2
 Weather data link page 10-4
 Weather product symbol 10-5
 Weather product symbols 10-6
 Weather warnings 10-5
 Wind direction 10-5
 Wind speed 10-5

X

XM weather 10-4
 XPDR softkey 4-4

Blank Page



Garmin International, Inc.
1200 East 151st Street
Olathe, KS 66062, U.S.A.
p: 913.397.8200 f: 913.397.8282

Garmin AT, Inc.
2345 Turner Road SE
Salem, OR 97302, U.S.A.
p: 503.391.3411 f: 503.364.2138

Garmin (Europe) Ltd.
Unit 5, The Quadrangle
Abbey Park Industrial Estate
Romsey, SO51 9DL, U.K.
p: 44/0870.8501241 f: 44/0870.8501251

Garmin Corporation
No. 68, Jangshu 2nd Road
Shijr, Taipei County, Taiwan
p: 886/2.2642.9199 f: 886/2.2642.9099

www.garmin.com

Free Manuals Download Website

<http://myh66.com>

<http://usermanuals.us>

<http://www.somanuals.com>

<http://www.4manuals.cc>

<http://www.manual-lib.com>

<http://www.404manual.com>

<http://www.luxmanual.com>

<http://aubethermostatmanual.com>

Golf course search by state

<http://golfingnear.com>

Email search by domain

<http://emailbydomain.com>

Auto manuals search

<http://auto.somanuals.com>

TV manuals search

<http://tv.somanuals.com>