

Elite™ 12ppm

USER'S MANUAL



 **GCC**
TECHNOLOGIES

Contents

1: Introduction and Installation

Using this manual	1-1
Elite 12ppm highlights	1-1
How to set up your Elite 12ppm	1-3
Overview	1-3
Why would I install PPD files or configure the control panel, printer driver, or ports?	1-3
Setting up the Elite 12ppm	1-5
Choosing a location for the printer	1-5
Removing packing	1-6
The Elite 12ppm Configuration Page	1-7
Installing or replacing the toner cartridge	1-7
Connecting power to the Elite 12ppm	1-10
Using the paper tray	1-10
Using the Multipurpose feeder	1-12
Elite 12ppm interface connections	1-14
Supported network protocols	1-17

2: The Elite 12ppm control panel

Control panel (LCD) display window	2-1
Control panel status LEDs	2-1
Control panel function keys	2-2
The Elite 12ppm menu system	2-5
Do I need to change control panel menus?	2-5

Language	2-5
Print Help Page	2-6
Print (1) Sample Page (s)	2-6
Printer Info	2-6
Paper Handling	2-7
Emulations	2-8
Interfaces	2-11
Info Pages	2-12
Print Control	2-12

3: *Using a Macintosh*

Software Installation	3-1
Selecting the LaserWriter 8 printer driver	3-3
Printing documents using the LaserWriter 8 printer driver	3-5
Selecting Page Setup options	3-5
Page Attributes	3-6
Selecting Print options	3-7
Manual feed printing	3-12
Naming the Elite 12ppm	3-13

4: *Using Windows 3.1*

Setting Windows 3.1 printing options	4-3
Advanced Options	4-5
Port assignment- Windows 3.1	4-5
Installing printer description files	4-7
Printing from Windows 3.1 applications	4-7

5: *Using Windows 95*

Windows 95 printing software overview	5-1
Plug and Play installation	5-1
Using Add Printer	5-1
Solutions to possible software installation problems	5-7
Exploring the Properties dialog box	5-9
The Device Options page	5-9
Updating printer memory	5-10
The Details page	5-11
The Paper page	5-11
The Graphics page	5-12
The Fonts page	5-12
The PostScript page	5-12
Installing printer description files	5-13
Installing printer description files using Windows Explorer	5-13
Installing printer description files using an MS-DOS window	5-15
Printing from Windows 95 applications	5-16
Selecting print options	5-16
The Print Properties dialog box	5-17

6: *Using Windows NT 3.51*

Windows NT printing software overview	6-1
Select and configure a communications port	6-4
Selecting Page Setup and Print options	6-6
Print Setup options	6-6
Print options	6-7

7: Using Windows NT 4.0

Windows NT 4.0 printing software overview	7-1
Exploring the Properties and Document Defaults dialog boxes	7-5
The Properties dialog box	7-5
The Device Settings page	7-5
Updating the printer driver	7-6
Other general items in the Device Settings	7-7
Other GCC-specific items in the Device Settings	7-7
The Document Defaults dialog box	7-7
Opening the Document Defaults dialog box	7-7
GCC-specific items	7-8
Other items in the Advanced page	7-8
Installing printer description files	7-9
Installing printer description files using Windows Explorer	7-9
Installing printer description files using MS-DOS window	7-11
Printing from Windows 4.0 applications	7-12
Selecting print options	7-13
The Print Properties dialog box	7-13

8: Using DOS

Overview of setup and printing from a DOS application	8-1
Overview and setup and printing from DOS command line	8-1
Port configuration – DOS	8-2
Selecting a printer driver	8-3
Using the Copy command	8-4

9: Fonts

Introduction	9-1
Resident PostScript fonts	9-1
PCL resident font catalog	9-4
Font compatibility	9-5
Downloading fonts from a Macintosh	9-6
Additional LaserWriter Utility functions	9-8
Downloading fonts from Windows	9-9
Using an external hard disk with the Elite 12ppm	9-9
Initializing an external hard disk	9-11

10: Maintenance and Troubleshooting

Cleaning the rollers every 12,000 pages	10-1
Handling and storing toner cartridges	10-1
Toner spills	10-1
Packing the printer to transport it	10-2
Printing Problems	10-2
Detailed Troubleshooting	10-5
Diagnosing errors from print output	10-11
Service and Support	10-14
GCC's World Wide Web site	10-14
Dealer and Service Center support	10-14
Extended warranties	10-14
Software upgrades	10-14
Transporting your printer	10-14
Consumables, accessories, and upgrades	10-14

11: Adobe Acrobat

Installing Adobe Acrobat Reader	11-1
Opening Documents with Acrobat Reader	11-2
Understanding the Acrobat Screen	11-2
Moving Through Pages	11-2
Finding Text	11-3
What's on this CD-ROM	11-3

Appendices

A: Printer specifications	A-1
B: Paper specifications and recommendations	B-1
C: Adding memory to your printer	C-1
D: Adding and configuring optional paper trays	D-1
E: QuickDraw GX	E-1
F: PCL	F-1
G: Interface connector pinouts	G-1
H: Radio and television interference	H-1
I: Elite 12ppm consumables and optional accessories	I-1
J: Glossary	J-1
K: Warranties and Licenses	K-1

1: Introduction and Installation

Congratulations on your purchase of a GCC Technologies Elite 12ppm laser printer. You now have a fast, high-quality, versatile solution for all your printing needs.

Using this manual

This manual has all the text of the Quick Install (printed) guide, along with further information about configuring your printer and computer. To navigate around the manual, see the section “Using Adobe Acrobat with the Elite 12ppm CD-ROM” either in this manual or in the Quick Install guide. You’ll also find the Networking Guide, various installation guides, and printer specifications. Elsewhere on this CD-ROM you’ll find printing software for your computer.

Elite 12ppm highlights

Note: GCC makes several models of the Elite 12ppm. Your model may not incorporate all these features.

True 1200 dots per inch printing

All Elite 12ppm models print at 600 or 300 dpi. The Elite 1212 also prints at a true 1200 dots per inch (dpi). All models give you razor-sharp text and detailed graphics.

Fast processing power

The AMD 29040 50 MHz RISC processor gives you faster printing of complex pages.

Full support for mixed-platform printing

The Elite 12ppm accepts jobs in PostScript Level 2 and PCL 5 formats from Macintosh, Windows, MS-DOS, and UNIX based computers.

Low operational costs

The Elite 12ppm is an Energy Star compliant low power consumption printer, and its one-piece microfine toner cartridge prints an average of 6,000 pages.

Full network capability

The Elite 12ppm comes with Ethernet to allow connection to an Ethernet network. It also has LocalTalk as standard, and supports NetWare and TCP/IP.

WebAdmin remote printer management

If you have an Ethernet network that supports TCP/IP, you can remotely view and configure any Elite 12ppm using a World Wide Web browser.

Better halftones with AccuGray

GCC's exclusive AccuGray software ensures that halftones reproduce with consistent brightness, regardless of the screen frequencies used, making for more detailed photographs.

Edge to edge printing

The Elite 12ppm can print an area right up to the edge of the paper for full bleeds.

All ports active feature

The Elite 12ppm can accept print jobs from a Bidirectional Parallel port and LocalTalk/Serial and Ethernet networks at the same time.

Flexible paper handling

The Elite 12ppm has a 250-sheet paper tray that can accept paper up to legal size (8.5 x 14 inch, 215.9 x 355.6 mm), and also includes an additional paper feed source for envelopes and postcards.

Full featured front panel display

The front panel display of the Elite 12ppm displays messages that make it easy to configure and control the printer; you get continuous information as jobs print.

SCSI interface (1200 dpi model only)

The Elite 1212 has a SCSI interface that allows you to connect an external SCSI hard drive for additional font storage and faster printing.

Novell NEST Support (1200 dpi model only)

The Elite 1212 supports Novell's NEST system which allows you to connect an Elite 12ppm to a Novell network without needing to dedicate a computer as print server.

Environmentally friendly

The Elite 12ppm emits extremely small amounts of ozone, well within the safety limits, and is engineered to reduce dust emissions for a healthier work area.

Optional equipment

A 500-sheet paper tray and an envelope feeder are available options to make the Elite 12ppm the printer you need.

Fast and easy ordering of upgrades and consumables

Replacement toner cartridges and optional equipment are available from your GCC distributor or direct from GCC at 1-800-422-7777. Visit our web store at www.gccdirect.com.

How to set up your Elite 12ppm

Overview

You'll carry out these steps to get your printer up and running:

- Selecting a location for the printer.
- Unpacking the printer and connecting it to a power outlet.
- Installing the toner cartridge.
- Connecting the printer to a computer or network.

The detailed instructions for these steps are in this section of the manual.

Once you have the printer physically set up, you'll install software on every computer that will use it. This includes:

- Installing the printer driver on a Macintosh or Windows computer.
- Installing PPD (PostScript Printer Description) and other files, if necessary.
- Configuring the control panel, driver, and ports, if necessary.

The detailed instructions for these steps are in the appropriate section of this manual, according to which type of computer or operating system you use.

Why would I install PPD files or configure the control panel, printer driver, or ports?

Installing PPD files

Although the standard software install gives the computer all the details of the printer, a few software applications need you to install special files. If you don't have any of these applications on your computer, you don't need to install the files. GCC supplies PPD files for these applications:

- Adobe Illustrator® for Windows, versions 4.0 and 4.1.
- Adobe PageMaker® for Windows, versions 5.0 and 6.0.
- Aldus FreeHand® for Windows, all versions up to 4.0.
- MacroMedia FreeHand® for Windows, version 5.0.
- QuarkXPress® for Windows.
- Aldus FreeHand for Macintosh, versions 3.0 and 3.1.
- Aldus PageMaker for Macintosh, version 4.2.
- Adobe Separator for Macintosh, versions up to 3.2.

- Deneba Canvas® for Macintosh, versions 3.0 and later.
- QuarkXPress for Macintosh, versions 3.1 and later.
- Ready, Set, Go!® for Macintosh, versions 5.0 or later.

You may need to install these files for certain other applications. If this is the case, you'll find details in your application's manuals.

Instructions on how to install these files are in the sections for Macintosh or Windows.

Configuring the control panel, printer driver, and ports

Your Elite 12ppm printer has numerous settings you can adjust to make it meet your printing needs. However, many users are satisfied with the settings as supplied.

The sections of this manual on Macintosh and Windows list the steps you *must* take to configure the computer to print. The rest of each section covers the optional changes you can make. If you're not aware of any special circumstances in your printing it's unlikely that you'll need to make any optional changes.

However, if you need to make changes, there are three ways you can do this:

- Using the printer's control panel menus (or GCC's WebAdmin tool).
- Using the Printer Setup dialog box on your computer.
- In the Page Setup and Print dialog boxes of many applications.

The place where you make changes affects how widespread those changes will be.

- If you change settings in the Elite 12ppm's control panel, this sets the default for all computers using the printer. If you don't make any control panel changes, the factory defaults will be the default settings. If you make changes with GCC's WebAdmin utility, this has the same effect as if you made them at the printer's control panel.
- If you change settings in the Printer Setup dialog boxes on a computer, the new settings are now the defaults for all applications on the computer. If you change something from "Printer's Default," this overrides the printer control panel defaults for this computer only.
- If you change settings in the Page Setup or Print dialog boxes in an application, this overrides any other settings for that feature.
 - Some changes that you make revert to the defaults as soon as you've printed the document.
 - Other changes become the defaults every time you print that document.
 - Some will become the defaults every time you print from that application.

Different applications treat these changes in different ways.

GCC recommends that you make changes in the application's Page Setup or Print dialog boxes. If you find that you are making the same changes for every print job, use the Printer Setup dialog boxes or the Elite 12ppm control panel menus to make these settings the default.

You'll find instructions on changing the settings through the control panel menus (or GCC's WebAdmin tool) elsewhere in the manual. The instructions for changing the settings in the Printer Setup dialog boxes are in the sections on each type of computer or operating system.

Page Setup and Print dialog boxes vary from application to application. You'll find details in your application's manuals.

Setting up the Elite 12ppm

Choosing a location for the printer

Place the printer on a flat level surface in a well ventilated area away from direct sunlight and areas where the air temperature and humidity can vary. Do not obstruct the fan vent on the right side of the printer, and make sure that the fan vent does not blow air directly onto someone's face.

Use the diagram below to determine where to put your printer.

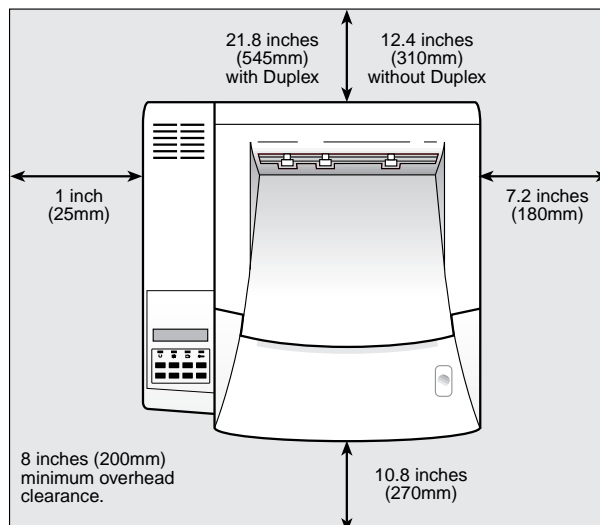

Removing the printer from the shipping box

Warning: The printer weighs about 30 pounds (about 14 kilograms).

Note: Save the packing materials inside the shipping box and put the box in a safe place; you will be able to repack the printer should you need to move it again.

1. Take the printer out of the of the box and remove the packing material.
2. Take the printer out of the plastic bag.
3. Take the documentation and CD-ROM out of the plastic bag.
4. Check that you have all of the following:

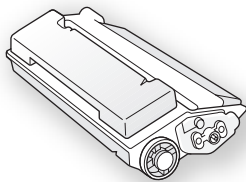

Toner cartridge
(in box)

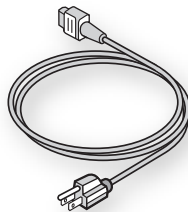

AC power cord

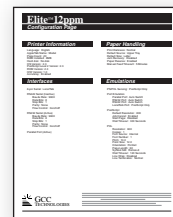

Configuration page

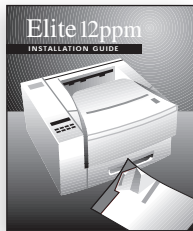

Installation guide

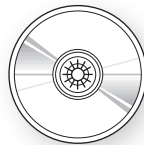

Elite 12ppm CD-ROM

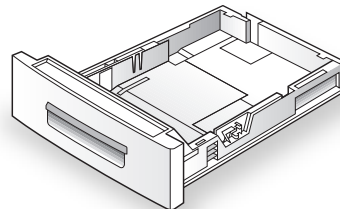

Universal paper tray

If any of these items are missing, contact your dealer or GCC Technical Support (781-276-8620) immediately.

You will need to provide a cable to connect your computer or network to the printer.

Warning: If you use the parallel port interface, the cable you use must be suitable for bi-directional transmission (IEEE 1284). Standard (unidirectional) parallel cables can cause errors in printing.

Removing additional packing

1. Remove the tape from the printer's top cover.

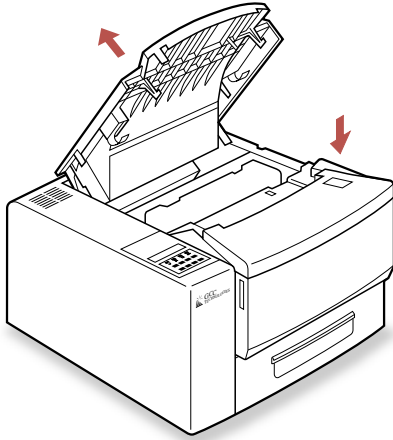

2. Press the release button on the top right of the printer.
3. Lift open the printer cover.
4. Remove the plastic foam block. Save it with the other packing materials.

The Elite 12ppm Configuration Page

Each Elite 12ppm package includes a configuration page. It was printed on *your* printer, at GCC's manufacturing facility. The page shows the hardware and software versions of the printer, factory default settings, and the hardware configuration of *your* Elite 12ppm.

Installing or replacing the toner cartridge

The toner cartridge contains a microfine plastic powder that is fused to paper during the print process. If your pages have an average of five percent coverage, you should expect to print about 6,000 pages with each toner cartridge; if you print graphics images you should expect to change the cartridge more often.

Warning: Do not touch the area toward the back of the inside of the printer (behind the toner cartridge). This area has a yellow warning label. It's unlikely that you would touch this area when changing a toner cartridge, but you may want to leave the cover open for a few minutes to let the area cool down.

1. Press the release button on the top of the printer to open it.
2. Lift open the printer cover.

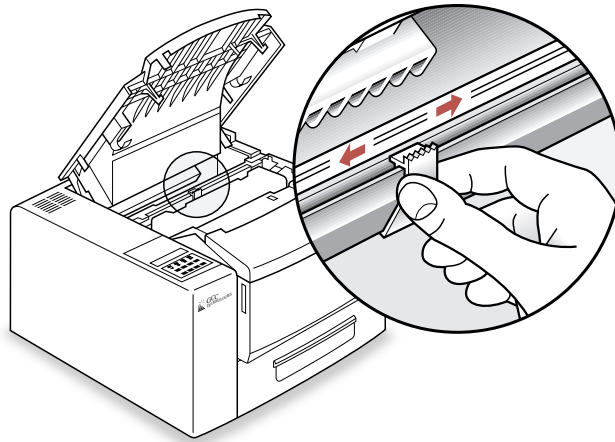

3. Move the yellow plastic slider from left to right a few times to remove dust and toner from any previous cartridges.
4. If you are replacing a cartridge, remove the old cartridge by lifting it up and out of the printer; otherwise, go to the next step.
5. Take the new toner cartridge out of its box and wrappings.

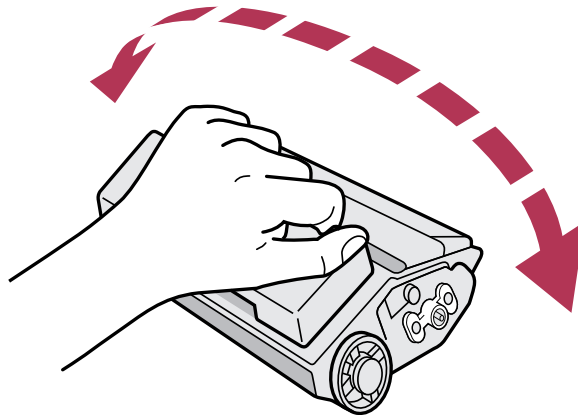

6. Distribute the toner evenly by gently rocking the cartridge a few times.

7. Pull the seal on the cartridge gently but firmly to remove it completely. Do not tug sharply or pull the seal at an angle.

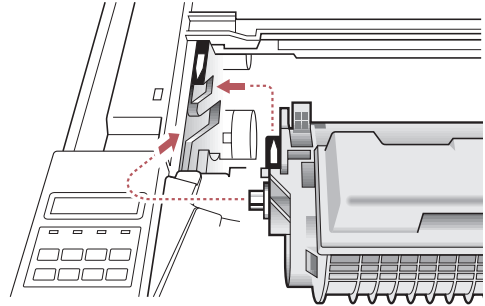
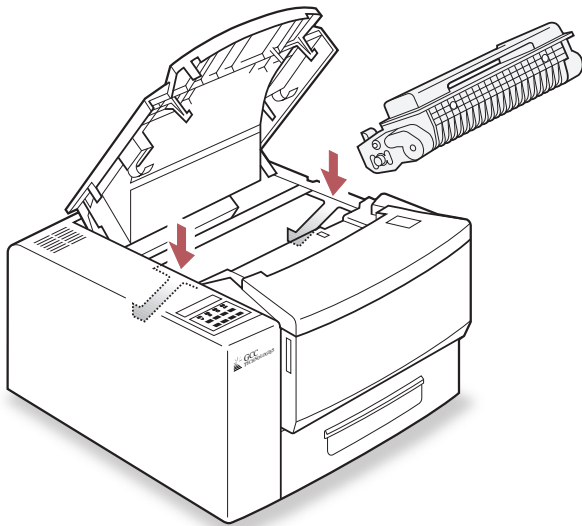
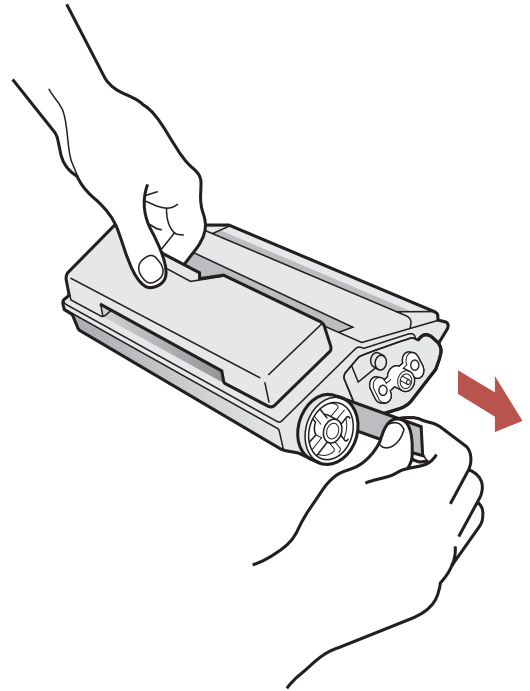

8. There is an arrow on the left side of the cartridge. There is a similar arrow on the left side of the printer. Align these two arrows and insert the cartridge down and into the printer completely.
9. Close the top cover so that it latches. If the top cover does not close and latch, you may not have fully inserted the toner cartridge. Open the cover and carry out step 8 again.

If you have replaced a used toner cartridge, you can resume printing when the printer warms up.

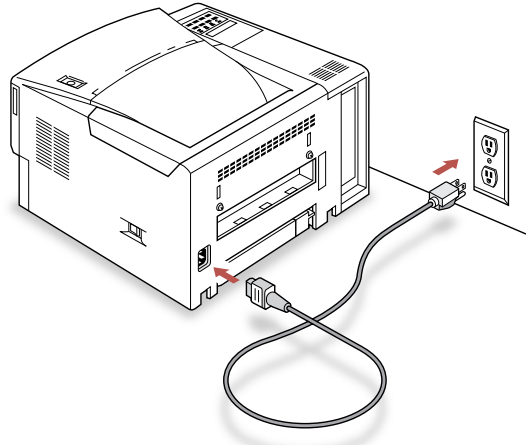

Connecting power to the Elite 12ppm

Plug the power cord into the socket located on the back of the printer, then plug the cord into an AC power outlet. Switch on the printer using the ON/OFF switch located on the right side of the printer.

Warning: Do not attempt to use an adapter to plug the power cord into a 2-pin socket. The third pin is for your protection; it grounds the printer. If you use a printer (or any electronic or electrical equipment) that has no ground connection, you run the risk of electric shock. If necessary, have a licensed electrician replace the socket.

Using the paper tray

The universal (standard) paper tray holds up to 250 sheets of 20 lb. (75 g/m²) copier-type paper up to 8.5 x 14 inches (215.9 x 355.6 mm). It can handle the following paper sizes:

- Letter
- Legal 13"
- Legal 14"
- Executive
- A4
- B5

You can use smaller sizes of paper and envelopes in the Multipurpose feeder—see the next section for details. The standard paper tray will also handle up to 50 transparency or label sheets in Letter or A4 size.

Loading paper into the tray

Note: Place letterhead paper face down and with the letterhead toward the front of the tray.

1. Remove the paper tray from the printer. Pull firmly using the handle at the front of the tray.
2. Adjust the guides at the rear of the paper tray to accommodate the length of the paper you intend to use. Adjust the smaller guide at the left (A) to accommodate paper up to A4 size. For sizes larger than A4, extend both of the guides (B).

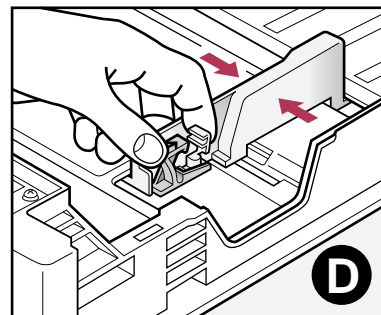
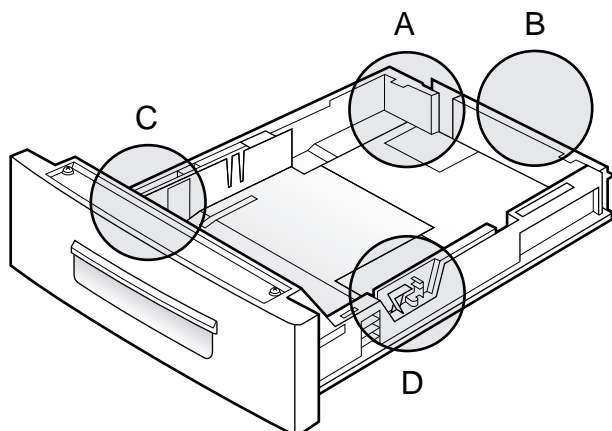
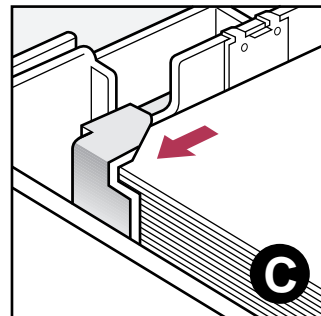
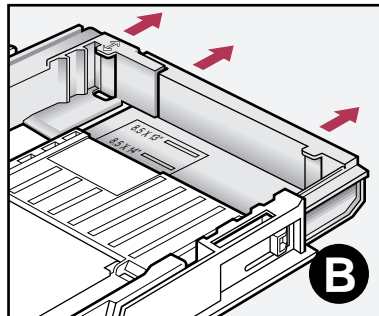
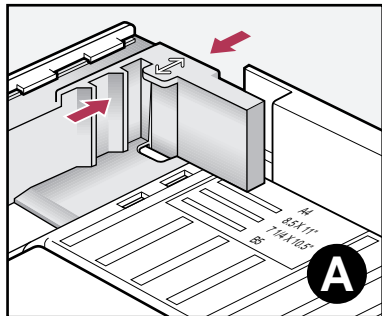
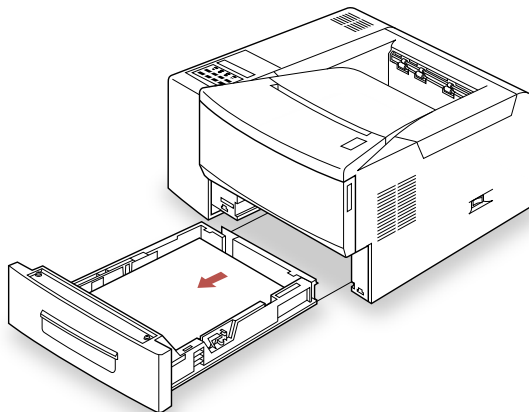

3. Make sure that the paper fits underneath the plastic tab at the rear of the tray and under the metal bracket at the front (C).
4. Place the paper in the paper tray and move the paper width guide (D) so that it lies next to the paper. Don't move the guide so close that it holds the paper tightly, because this may cause jams.

5. Replace the tray in the printer. Make sure you push it all the way in, so that the control panel displays the "ready" message.

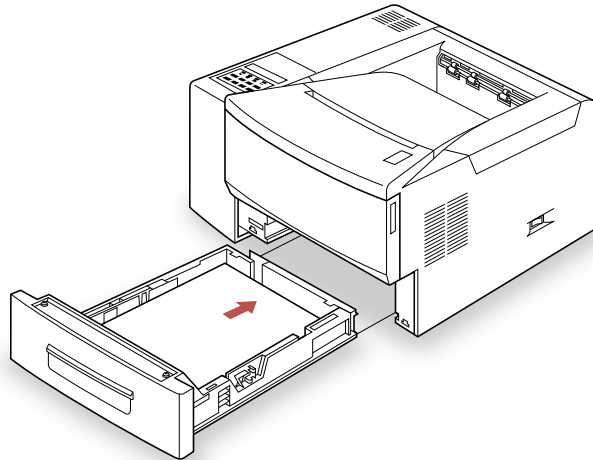

Using the multipurpose feeder

The multipurpose feeder holds up to an extra 80 sheets of 20 lb. copier-style paper, 40 transparencies, 40 sheets of labels, 10 envelopes or 25 postcards. You can also manually feed single sheets of paper or other media. The multipurpose feeder handles the following paper and envelope sizes:

- Letter
- Executive
- Postcard
- DL
- Legal 13"
- A4
- Commercial #10
- C5
- Legal 14"
- B5
- Monarch

Exact measurements of these paper sizes is in the appendix "Specifications."

You have to select the multipurpose feeder from a computer's Print dialog box (assuming you specified the main paper tray as the default paper source). See "Paper Source" in the sections on Macintosh and Windows for information on how to select the multipurpose feeder.

Loading Paper in the Multipurpose Feeder

1. Open the cover of the multipurpose feeder; it folds down to a 45° angle. If one side of the cover doesn't unlatch, push the cover gently toward that side.
2. Pull the tab to slide out the extension.
3. When the extension is fully extended, lift the tab up and toward you so that the folding part of the extension is in place.

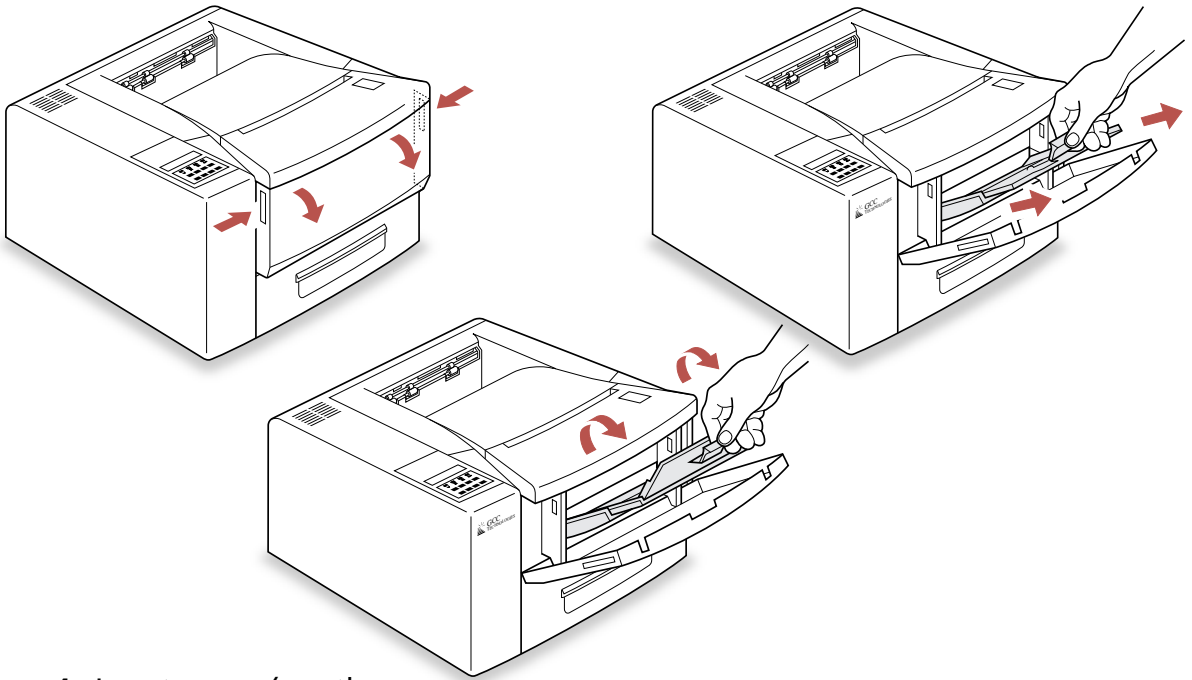

4. Insert paper (or other media). If necessary, slide the paper guide so that it lies against the edge of the paper. Insert letterhead face up with the top toward the printer, and envelopes face up with the flap down and to the right.

Note: The Elite 12ppm does not check the size of the media you insert in the multipurpose feeder (unlike the paper trays). Make sure you're using the paper size you specified in your application.

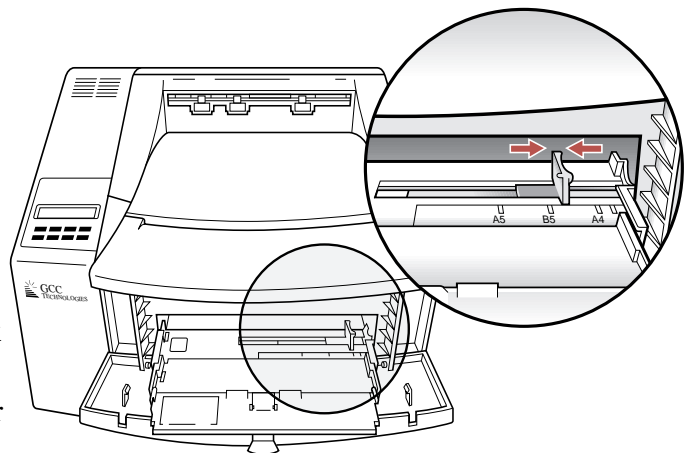

Note: If you are using legal-size paper, you may need to support the stack to help it feed properly.

When you close the multipurpose feeder, first move the paper guide back to the right side. Then fold the extension and slide it back into the main part of the feeder. Now close the cover; this lifts the feeder back to the upright position.

Optional paper handling accessories

Optional on the Elite 12ppm is a face-up paper tray that attaches to the rear of the printer. This gives you a straight-through paper path (which you may need for thicker media) in conjunction with the multipurpose feeder.

Other optional units include a 500-sheet feeder and paper tray, and a 50-envelope tray that fits inside the 500-sheet feeder.

Elite 12ppm interface connections

The Elite 12ppm includes Ethernet, LocalTalk, RS-422 serial, and bidirectional parallel interfaces; the LocalTalk and RS-422 serial interfaces share the same 8-pin mini-DIN port.

With your printer's *all ports active* feature, all the interfaces are simultaneously active, which means you can print through more than one interface at a time. You don't have to select a port; this feature works automatically.

Note: If you are connecting through the parallel interface, *insert this plug before you make any other interface connections*. If other plugs are inserted it's difficult to connect the parallel plug.

- The 8-pin DIN connector (A) can be used as either a LocalTalk network interface or an RS-422 serial interface. LocalTalk is the default setting. If you want to use this as a serial interface, you'll have to change settings in the printer's control panel menus.
- (1200 dpi model only) You can add an external hard disk for font storage using the SCSI interface (B). It is *not* used for communication between the printer and computer.
- If you want to connect your printer to a single PC-compatible computer, use the parallel interface (C). Alternatively, you can connect the RS-422 serial interface port to the PC's serial port, but the serial port transmits data much slower than a parallel port or network.

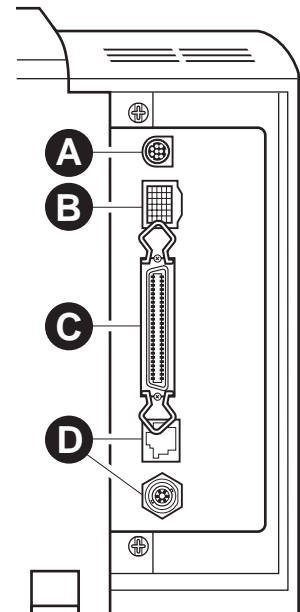

- The Ethernet network interface (D) is used to connect the printer to an Ethernet network. The interface contains one or two connectors: an RJ-45 connector (upper) for connecting to 10BASE-T networks and (*1200 dpi model only*) a BNC connector (lower) for connecting to 10BASE-2 networks.

Note: Some interfaces have specific settings that you must select through the printer's control panel Interfaces submenu.

Connecting cables correctly

Most cables come with some kind of mechanical locking device. Be sure to use these locking devices, otherwise you may experience intermittent errors or the printer will fail to operate altogether.

- There is no locking device on LocalTalk or RS-422 Serial connectors. Make the plug is pushed all the way into the socket.
- When you have inserted a Parallel port plug, lift up the wire clips at either end of the socket so that they fit into the slots on the sides of the plug.
- 10BASE-T plugs have a locking tab similar to plugs on telephone cords. When the plug is fully inserted the tab clicks into place.
- 10BASE-2 plugs have a rotating collar. Plug the cable onto the socket, then rotate the collar clockwise to lock it.

Improperly inserted cables are the cause of many networking and printer-related problems.

LocalTalk connection

The Elite 12ppm uses the LocalTalk cable system to connect to AppleTalk-compatible networks. This connection forms a chain; do not connect devices so that it forms a circle.

Important: You need a connector kit for each device on the network. Therefore, you need two connector kits to connect the printer to one computer, and so forth.

To plug in LocalTalk cables:

1. Switch off the printer.
2. Connect one LocalTalk connector box to the LocalTalk port on the printer.
3. Connect one LocalTalk connector box to the printer port (identified by a printer icon) on the back of the Macintosh.

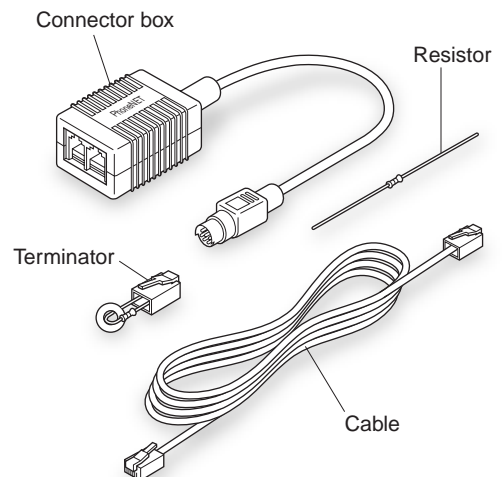

4. Connect the LocalTalk boxes together with one of the LocalTalk cables. You will only need one of the LocalTalk cables (for one Macintosh and one printer).
5. Insert resistors. (Depending on the type of cables you are using, terminating resistors may be needed. Please refer to the documentation included with your cable kit for instructions.)
6. Switch on the printer.
7. Verify the printer's LocalTalk setting. The 8-pin serial submenu, accessed from the printer's control panel, should be set to LocalTalk. LocalTalk is the factory default, so you should not need to change the setting.

Bi-directional (parallel) connection

The bi-directional parallel connection between the printer and a PC requires a standard 36-pin bi-directional cable (to IEEE 1284 standards). The length of a bi-directional cable can be up to 10 meters or 30 feet. This interface offers the fastest communication between a PC and the printer (unless the PC and printer support Ethernet).

Serial connections

You can connect a PC to the printer by using the RS-422 connection and the computer's serial port. In general, this is not recommended, because data is transmitted more slowly than if you connect the parallel port on the PC to the parallel port on the printer, or use a network. Therefore, printers connected through the serial port take longer to print.

RS-422 serial enables data to travel in either direction between the printer and a single computer. For an RS-422 serial connection, use an 8-pin serial cable. The RS-422 interface allows a cable length of up to 300 feet.

Note: You need to set the printer for Serial communication. The 8-pin serial submenu, accessed from the printer's control panel, should be set to RS422. LocalTalk is the factory default, so you will need to change the setting. Configure the serial interface settings. In order for successful serial communications between the printer and the PC to take place, the configuration of the serial interface of each device must match.

Ethernet network connection

The Elite 12ppm printer includes an Ethernet network interface. The Ethernet interface on your printer lets you connect to an Ethernet network via one or two types of Ethernet cables: 10BASE-T and 10BASE-2 (*1200 dpi model only*).

- **10BASE-T (Unshielded Twisted-Pair or UTP)**

Your printer connects to 10BASE-T Ethernet via the 10BASE-T (RJ-45) connector on the network card. The cabling used is Unshielded Twisted-Pair (UTP).

- **(1200 dpi model only) 10BASE-2 (RG-58, Thin Coax, or Thinnnet)**

Your printer connects to 10BASE-2 Ethernet via the 10BASE-2 (BNC) connector on the network card. The cabling used is called RG-58 or Thin Coax.

Supported network protocols

- **EtherTalk**

EtherTalk is Apple's name for the AppleTalk network protocol running over Ethernet cabling.

- **NetWare**

NetWare is Novell's system for Ethernet connection.

- **TCP/IP**

TCP/IP is a networking protocol used by various vendors of network software.

If you need to know more about these protocols, refer to the Networking Guide on this CD-ROM. You'll also see how to connect your printer to make it available on other networks such as those running Windows for Workgroups 3.11, Windows 95, and Windows NT.

2: The Elite 12ppm Control panel

Introduction to the Elite 12ppm control panel

You use the Elite 12ppm's control panel to get information about your printer and to adjust specific printer functions. It includes an LCD display window, four LEDs that show the status of the printer at all times, and eight pushbuttons.

Control panel (LCD) display window

The LCD display window has several functions. It shows:

- The current status of the printer.
- A more detailed explanation of errors.
- Prompts to complete tasks, like "Insert Paper."
- The Elite 12ppm menus and submenus.

When the printer is not printing, you'll see the printer's name and "Ready" in the display window.

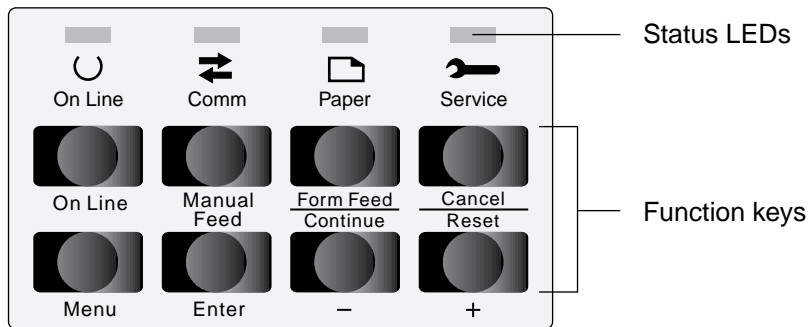

Control panel status LEDs

The control panel status LEDs show you the following:

- When the **On Line** LED is solid (lit and not flashing), the Elite 12ppm is ready to receive data and print. When you turn the printer on, this LED flashes while the printer is initializing.
- ↔ When the **Comm** LED flashes, one of the Elite 12ppm's interface ports is receiving or transmitting data.



The **Paper LED** is solid in one of the following situations:

- The printer is out of paper
- The wrong size paper is loaded in the paper tray
- The printer is waiting for you to insert paper because you specified manual feed in the paper source section of your application's Print dialog box.



When the **Service LED** is flashing, you need to perform some type of simple service procedure in order to continue printing. If this LED is solid, the printer needs to be serviced by GCC authorized service personnel.

When a LED indicates that the printer needs attention, you'll see a message explaining the situation in the display.

Control panel function keys

On Line key

You use the On Line key to set the printer either on line or off line. The printer is normally on line — that is, ready to receive data from computers and print it. If you need to use the control panel menu system, you must set the printer off line. Press the On Line key to set the printer off line. After you've finished using the menu system, press the On Line key again to set the printer back on line.

If you press the On Line key while a document is being printed, the On Line LED flashes. This indicates that the printer will finish processing this document and any other waiting documents, and then go off line.

Manual Feed key

You use the Manual Feed key:

- When you select manual feed as the paper source for the document in your application's Print dialog box.
- When the control panel requests you to load a paper size that is not loaded in the printer's paper trays.

In both cases, you load the multipurpose feeder with the correct size paper and press the Manual Feed key.

During the period when you can load paper, the printer displays a "Load Paper" message. Any jobs received while the printer is displaying this message will wait to print until you load paper and the current document finishes printing.

The amount of time that the printer will wait for you to load paper can be set through the control panel. It's located in the Manual Feed Timeout submenu of the Paper Handling menu. The default time is 300 seconds (5 minutes).

If you do not load paper within the specified time, the printer discards the job and carries on printing any other jobs that are pending.

Form Feed/Continue key

You use the Form Feed/Continue key:

- When the printer needs a Form Feed command for PCL5 print jobs from certain applications.

Some applications send data for a PCL 5 print job *except* the command to make the printer feed paper. In this case you should press the On Line key and then press the Form Feed/Continue key.

- When you want the printer to print on the paper in the paper trays, even though they do not hold the specified paper sizes.

The Form Feed/Continue key overrides the printer's requests that you load a different size of paper or load paper through the multipurpose feeder. In both cases the printer will draw paper from the 250-sheet cassette, whatever size of paper it holds.

Cancel/Reset key

You use the Cancel/Reset key:

- To cancel a PostScript job that is either processing or waiting to print.

To cancel printing, press the On Line key and then hold down the Reset key for three seconds. You'll see "Cancelling job" in the display window. It's possible that this feature has been disabled through the menu system; in this case, pressing these keys will have no effect.

If the Job Cancel feature has been disabled, you can enable it by going to the PostScript menu in the Control Panel and changing the setting in the Job Cancel submenu. The default setting for this feature is enabled.

- To reset the control panel menu and submenu settings to the factory settings (the printer must be off line).

If you want to reset all the menu items to their default settings, press the On Line key to take the Printer off line, then hold down the Cancel/Reset key for five seconds. You'll be prompted to either press the Enter key to confirm that you want to reset all menu items, or to press the Cancel/Reset key again to leave menu items as they are.

If you want to reset all items in one menu to the default settings, navigate through the menu system until you see the menu you want to reset. Hold down the Cancel/Reset button for five seconds. You'll be prompted to either press the Enter key to confirm that you want to reset all the items on this menu (including submenus), or to press the Cancel/Reset key again to leave these menu items as they are.

If you want to reset just one submenu to the default settings, navigate through the menu system until you see the submenu you want to reset. Hold down the Cancel/Reset button for five seconds. Because you are resetting only one item, you won't be prompted to confirm or cancel this change.

Note: Some items will not reset until you switch the printer off and on again.

Menu key

You use the Menu key to get to the menu system. First, you must press the On Line key to take the printer off line. You can only get to the menu system when the printer is off line.

You'll use the printer's menus if you need to configure printer functions or get information about current settings.

Note: You'll only need to change the settings on the menus if you have specialized printing or connection needs. The factory settings suit most users.

To see the menus, first press the On Line key to take the printer off line. Then press the Menu key. Each time you press the Menu key you'll see one of the main items. There's a full list of menu items later in this section.

When you are finished in the menu system, press the On Line key to leave the menu system and place the printer back on line and ready to print.

Enter key

You use the Enter key:

- To see submenus.

"Press Enter..." appears in the display window to prompt you to press the Enter key to see a submenu(s).

- To save changes when you change main menu or submenu settings.

After you make a change to a main menu setting or submenu setting, press the Enter key to save the new setting. An asterisk (*) will appear in the display window to the right of the setting to confirm that new setting has been saved.

- To find out which port is being used for the current print job.

Press the Enter key when the Elite 12ppm is processing a job (when the Comm LED is flashing). The LCD display window shows the name of the interface port that is receiving data.

+ and - keys

You use the + and - keys to move through main menu and submenu settings. You can use these keys only when the printer is off line.

The Elite 12ppm menu system

The menu system consists of a number of main menus. Some main menus contain sub-menus. Some menus only give you information, while others let you change settings.

Depending on your choices, some menus may not be available. For instance, the factory defaults set the PS/PCL Sensing menu to PostScript Only, and you cannot access the PCL menu. If you changed this menu setting to Auto Switch or PCL Only, the PCL menu would be accessible.

Note: Items that appear in **bold** in this section are the factory default settings.

Reminder: Press the Enter key to save a new setting. An asterisk (*) will appear next to the new setting confirming that your changes have been saved.

The main menu items are:

- | | |
|-----------------------------|----------------------------|
| 1. Language | 6. Emulations |
| 2. Print Help Page | 7. Interfaces |
| 3. Print 1 Sample(s) | 8. Print Info Pages |
| 4. Printer Info | 9. Print Control |
| 5. Paper Handling | |

Do I need to change control panel menus?

The factory default menu settings suit most users. If you have specialized printing or connection needs, you may find that you need to change these settings.

We suggest that you read the remainder of this section to understand what the menu items can control. If you decide that you can usefully change some settings, we advise that you first print out a Help page (described below).

The Help page shows the current settings of all menus. Items in bold are the current settings. Menus which cannot be accessed in the current configuration are grayed out.

If you change settings, make a note on the Help page of the setting(s) that you've changed. This gives you a record of changes and may help you understand what needs to be done if your printer behaves in a way users don't expect.

1. Language

This menu lets you change the language of the messages in the display window. Languages are **English**, Français, and Deutsch.

2. Print Help Page

This prints a chart of all the items on the menus. Press the Enter key to print this chart. You cannot print this chart if the PS/PCL Sensing submenu is set to PCL only.

The Help page shows the current settings of all menus. Menus which cannot be accessed in the current configuration are grayed out.

3. Print (1) Sample Page(s)

You can print a sample page showing graphics and text. If you want to print more than one copy of this sample page, press the + and - keys to change the number of copies. Press the Enter key to print the page(s). You cannot print this page if the PS/PCL Sensing submenu is set to PCL only.

4. Printer Info

This menu has subitems which display general information about your printer. Press the Enter key to see the subitems.

- Ram Installed: The total amount of RAM in the printer.
- Ethernet Address: The Ethernet address.
- S/W Version: The version of the printer's operating system.
- H/W Version: The version of the printer's hardware.
- Page Count: The total number of pages printed.

5. Paper Handling – press the Enter key to access the submenus.

Submenu	Settings	Notes
Default Source: Which paper tray is used if the print job does not specify a paper tray.	Tray 1 , Tray 2, MPFeeder (multipurpose feeder), or Manual Feed.	Only available paper trays will be shown.
Default Destination: Which paper output tray is used if the print job does not specify a paper output tray	Top (face down) , or Rear (face up)	
Default Size: The “expected” paper size to print whenever a print job does not specify a paper size.	Letter , Legal, Legal 13”, Executive, A4, B5, Postcard, Commercial #10, Monarch, DL, or C5.	
Jam Recovery: After you clear a jam, the printer reprints any pages that were inside the printer at the time of the jam. With Jam Recovery enabled, pages that were exiting into the output tray will also be reprinted.	Disabled or Enabled.	Printing is slightly faster when Jam Recovery is Disabled, as more of the printer’s RAM is needed to store page details.
Paper Reserve: Whether the printer will draw paper from another paper tray if the selected paper tray is empty or has the wrong size paper. (The reserve paper tray must contain the same size paper.)	Enabled or Disabled.	If enabled, the printer prints from another paper tray when the paper tray specified by the print job is empty or has the wrong size paper. If Disabled is selected, the printer displays a message to load a paper tray.
Manual Feed Timeout: How long the printer will wait for paper to be put in the multipurpose feeder after the computer has sent a manual feed request to the printer.	Range from 30-600 seconds (in 30-second increments), or Never Timeout. Default is 300 seconds (5 minutes).	If you don’t place paper in the feeder before the timeout occurs, the job will not be printed. You’ll have to send it again.

6. Emulations – press the Enter key to access the Emulations submenus. These menus contain additional submenus.

Submenu	Settings	Notes
PS/PCL Sensing: Whether the printer will automatically switch between PostScript and PCL emulations, or print only PostScript or only PCL jobs.	Auto switch, PostScript only , or PCL only.	To print PCL jobs the factory setting (PostScript only) must be changed to either Auto switch or PCL only. See the note below this table.
Port Emulations (5 submenus)		The Port Emulations submenu only appears when PS/PCL sensing is set to Auto switch.
Parallel: Whether the parallel port will automatically switch between PostScript and PCL emulations, or print only PostScript or only PCL jobs.	Auto switch, PostScript only , or PCL only.	See note below.
RS422: Whether the RS422 port will automatically switch between PostScript and PCL emulations, or print only PostScript or only PCL jobs.	Auto switch, PostScript only , or PCL only.	See note below.
LocalTalk: Whether the LocalTalk port will automatically switch between PostScript and PCL emulations, or print only PostScript or only PCL jobs.	Auto switch, PostScript only , or PCL only.	See note below.
EtherTalk: Whether the EtherTalk port will automatically switch between PostScript and PCL emulations, or print only PostScript or only PCL jobs.	Auto switch, PostScript only , or PCL only.	See note below.
Lpd: Whether the Lpd port will automatically switch between PostScript and PCL emulations, or print only PostScript or only PCL jobs.	Auto switch, PostScript only , or PCL only.	See note below. This option will only appear if it is configured.
TCP direct: Whether TCP will automatically switch between PostScript and PCL emulations, or print only PostScript or only PCL jobs.	Auto switch, PostScript only , or PCL only.	See note below. This option will only appear if it is configured.
NEST (1200 dpi model only): Whether NEST will automatically switch between PostScript and PCL emulations, or print only PostScript or only PCL jobs.	Auto switch, PostScript only , or PCL only.	See note below. This option will only appear if it is configured.

Note: Your printer and each individual port can be set to accept jobs in PostScript only, PCL only, or to switch automatically between the two. If you set the printer to Auto Switch, it will accept either PostScript or PCL documents without you having to change settings.

Your printer will work more efficiently if you change only the ports that actually need Auto Switch. This

means that any other ports that only need to accept a single standard will not examine each print job to see whether it's PostScript or PCL.

However, if you choose Auto Switch for any port (or the entire printer), you'll use more printer RAM than if you choose PostScript only or PCL only.

Emulations (continued)

Submenu	Settings	Notes
PostScript (5 submenus)		The PostScript submenu will only appear when the PS/PCL Sensing option is set to Auto Switch or PostScript only.
Default Resolution: The default PostScript output resolution (in dots per inch).	Resolution options depend on the model being used. Default is the highest resolution available for the model.	
Default screens: Opens a submenu which lets you set the screen frequencies for 300 dpi, 600 dpi, and 1200 dpi (<i>if available</i>).	Default line screens are 53 for 300 dpi, 85 for 600 dpi, and 106 for 1200 dpi.	Press the Enter button to show these submenus. Press the Menu button to move from resolution to resolution.
AccuGray: Improves the look of halftones (photographs), especially those printed at higher line frequencies.	Enabled or Disabled	AccuGray does not work with all applications, and documents may print more slowly.
Job Cancel: Whether the Cancel/Reset key is able to cancel the PostScript printing process.	Enabled or Disabled	
Start Page: Whether the printer prints a Start page every time the printer is switched on.	Enabled or Disabled	If the PS/PCL Sensing option is set to PCL only, the Start Page will not print even if this menu is set to Enabled.
Wait Timeout: How long the printer waits for more input after printing all the input received (but without receiving a message saying that the job is complete).	From 45 to 120 seconds in 15 second increments, or Never Timeout.	Some applications may change this setting during the printing process. In some cases the change will be permanent and the new timeout setting will appear in the display. You can reset it, or, if the application is one you use frequently, leave the new setting.
PCL (11 submenus)		The PCL menus will only appear when the PS/PCL Sensing option is set to Auto Switch or PCL only.
Resolution: The default PCL resolution (in dots per inch).	300 or 600	
Copies: The default number of copies.	From 1 to 99	
Font Source: Which default location fonts will print from — the printer's PCL resident fonts or additional fonts manually downloaded to the printer's RAM.	Internal or Downloaded	Downloaded does not appear if you haven't manually downloaded PCL fonts into the printer's RAM.
Font Number: The default font number.	From 1 upward (see notes)	The font number must correspond to a font available from the location specified by the Font Source submenu.

Emulations (continued)

either Pitch: The number of characters per horizontal inch for the default font.

From 0.44 to 99.99 in 0.25 increments. Default is **10.00**.

This submenu only appears if the default font uses fixed spacing (monospaced).

or Point Size: The point size of the default font.

From 4.00 to 99.75 in 0.25 increments. Default is **12.00**.

This submenu only appears if the default font is scalable and is proportionally spaced.

Orientation: The default alignment of the image on the page.

Portrait or Landscape

Page Length: The default number of lines on the page.

From 5 to 256. The default is **60** for letter size paper.

This setting may change if the settings in the Default Size submenu of the Paper Handling menu are set to a size other than the factory default.

Symbol Set: The set of character symbols the default font uses.

The character symbols the font supports (see notes). Default is **Roman-8**.

See the Fonts section of this CD-ROM for a list of the symbol sets for resident PCL fonts.

Wait Timeout: How long the printer waits for more input after printing all the input received (but without receiving a message saying that the job is complete).

From 45 to **120** seconds in 15-second increments, or Never Timeout.

Some applications may change this setting during the printing process. In some cases the change will be permanent and the new timeout setting will appear in the display. You can reset it, or, if the application is one you use frequently, leave the new setting.

Line Wrap: For “plain text” print jobs, whether the text at the end of a line will end at the margin and continue onto the next line, or whether the line of text will be cut off at the margin.

Disabled or Enabled.

Line Termination: For “plain text” print jobs, sets carriage return and line feed (form feed) commands to determine which is the end-of-line indicator.

Normal, CR=CRLF, LF=CRLF and FF=CRFF, or ALL.

7. Interfaces – press the Enter key to access the submenus. The Interfaces submenus also have submenus.

Submenu	Settings	Notes
8-pin serial	LocalTalk or RS422	If you change the 8-pin serial setting, you must restart the printer.
RS422 Serial (5 submenus)		The RS422 menu only appears when you choose the RS422 option in the 8-pin serial menu.
RS422 Baud Rate: The RS422 baud rate.	300, 600, 1800, 2400, 3600, 4800, 7200, 9600 , 19200, 38400, or 57600.	
RS422 Data Bits: The number of data bits sent with each serial byte.	8 or 7	
RS422 Stop Bits: The number of stop bits sent with each serial byte.	1 , 1.5, or 2	
RS422 Parity: The parity sent with each serial byte.	None , Even, or Odd	
RS422 Flow Control: Which flow control is used by the RS422 serial port.	XON/XOFF , XON/XOFF Input, or DTR	Always set this to DTR when you send a PCL job.
TCP/IP: Whether print jobs will be accepted over a TCP/IP network. There are twelve other submenus in the TCP/IP menu system; you will need to configure these to run TCP/IP. Full details of the menus and their recommended settings are in the TCP/IP section of the networking guide on this CD-ROM.	Enabled or Disabled.	TCP/IP will not be operational until you have configured the settings in the TCP/IP submenus. Until then, setting this switch to Enabled has no effect. When TCP/IP is configured, this menu will allow you to turn it on and off. For full details, see the TCP/IP section of the networking guide on this CD-ROM.
NEST (1200 dpi model only): Allows you to configure the printer on a Novell network without needing to use a computer as a print server.	Enabled or Disabled .	
Frame Type: The Frame Type of printers on the Novell network.	802.2 , 802.3, Ethernet II, or SNAP.	If the Frame Type differs from what you specified in the NEST software, the printer will not be available to the network.

8. Info Pages – The info pages menu lets you print four different pages of information. Press the + or - keys to access each individual page type. Press the Enter key to print the page you select. The printer will temporarily go on-line, print a page, and then go back off line to the menu.

Page Type	Settings	Notes
Configuration: A list of the control panel settings for each menu and submenu.	Press the Enter key to print the Configuration page.	This page only prints if the PS/PCL sensing menu is set to Auto Switch or PS only.
Font List: The resident fonts and any downloaded fonts.	Press the Enter key to print the Font list.	The list of fonts you'll see depends on the setting of the PS/PCL menu. Auto Switch shows all resident fonts, PS Only shows only resident PostScript fonts, and PCL Only shows only resident PCL fonts.
Help: A diagram of the control panel menu system.	Press the Enter key to print the Help page.	This page only prints if the PS/PCL sensing menu is set to Auto Switch or PS only. Menus and submenus will appear dimmed if you can't select them because of other menu settings (for instance, the PCL menus will be dimmed if you have set the PS/PCL menu to PS only).
Sample: Common graphics formats and elements, and different fonts and sizes.	Press the Enter key to print the Sample page.	This page only prints if the PS/PCL sensing menu is set to Auto Switch or PS only.

9. Print Control – press the Enter key to access the submenus.

Submenu	Settings	Notes
Print Control (five submenus)		
Darkness: Controls the overall darkness of the page.	Darkest, Darker, Normal , Lighter, or Lightest.	
TonerMiser (Elite 1212): Lets you use less toner, but with a reduction in image quality.	Enabled or Disabled .	Cannot be used if either Smoothing is enabled or print resolution is 1200 dpi.
Smoothing (Elite 1212): Reduces the jagged appearance of text and graphics.	Enabled or Disabled .	Cannot be used if either Toner Miser is enabled or print resolution is 1200 dpi.
Print Cal. Pages (Elite 1212): Prints a series of pages to be used in conjunction with the Calibration menu.	Press the Enter key to start the process.	You should examine the output and choose the page that looks best overall.
Calibration (Elite 1212): A range of settings corresponding to the pages printed using the Print Cal. Pages menu command.	Calibration 1 - Calibration 5. The default setting is set at the factory, and is different for each printer.	If necessary, change this setting to the Calibration number of the page that looks best (from those printed using the Print Cal. Pages menu command above).

3: Using a Macintosh

Software Installation

Software for the Macintosh is included on the Elite 12ppm CD-ROM provided with your printer. The automatic installer places all the printing software into the appropriate locations on your startup disk (the startup disk is the hard disk that contains the System and Finder™ files used to start your Macintosh).

To install the Elite 12ppm software:

1. Put the Elite 12ppm CD-ROM into the CD-ROM drive.
2. Open the folder labeled "Printing Software."
3. Double-click the Elite 12ppm Installer icon.
4. Click Continue. You'll see the Read Me file. Take some time to read this file. It contains last-minute information on the installation procedure, as well as updates on Elite 12ppm features and compatibility issues. After reading the Read Me file, you can print it (if a printer is available) or save it as a TeachText document.
5. Click Continue. You'll see the Install dialog box. Choose the file(s) you want to install.

If you want to install all the files for your 12ppm model (*recommended*), choose the model name and click the Install button.

If you want to only install certain files, scroll through the list and click on those files. You can select more than one file by holding down the Shift key as you click on the line. When you've selected all the files you want to install, click the Install button.

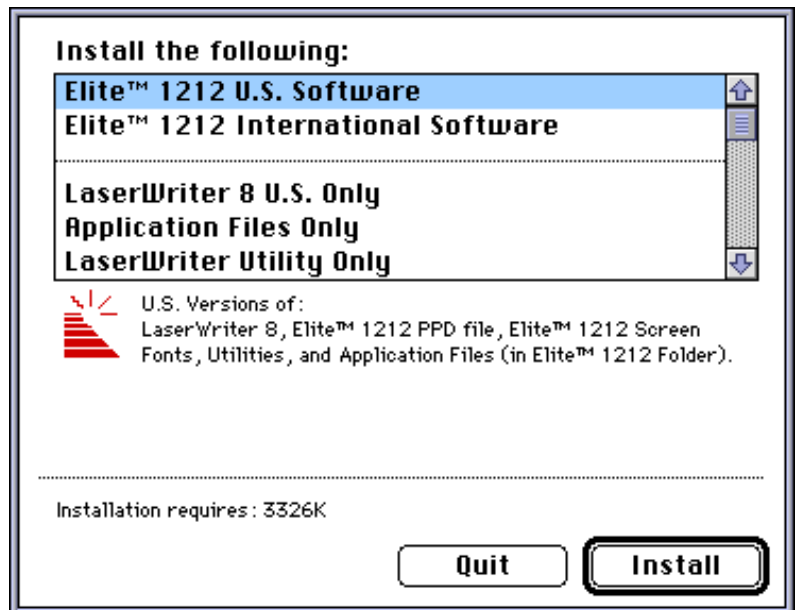

6. Click Install. You'll see a progress box describing the status of the installation. When the installation is complete, you'll see a dialog box indicating that the installation was successful.

Installing application-specific printer description files

A few applications require you to install additional files. These files give the application information about the capabilities of your printer and are often known as *Printer Description* files. The manuals included with an application tell you whether or not it requires these files. The **LaserWriter 8** driver, shipped with the Elite 12ppm, uses printer descriptions called PostScript Printer Description (PPD) files.

When you install software from the Elite 12ppm CD-ROM, the printer description files are copied into a folder named Application Files in the Elite™ 12ppm Folder. The Elite™ 12ppm Folder is then located in your startup disk's window. Follow the instructions below to copy each file into the folder specified by the application.

For more detailed information on printer description files, please refer to the documentation included with the application.

Elite 12xx (format 4)

This file is automatically placed in the Printer Descriptions folder during the initial (complete) software installation procedure. It's provided here because some application(s) may require it to be placed in a folder other than the standard **Printer Descriptions** folder.

GCxx.PPD (format 3.0)

This is the printer description file for Aldus® FreeHand™ versions 3.0 and 3.1, Aldus PageMaker® version 4.2x, Adobe Separator™ 3.2 or earlier, Canvas™ versions 3.0 or later, and other applications that require a .PPD file. Copy this file into the appropriate **PPD Folder** specified by the application you are using (e.g., the Aldus PageMaker **PPD Folder** is located in the **Aldus Folder**, which is located in the **System Folder**).

GCxx.PDX

This is the extension to the PostScript printer description file for Aldus FreeHand 3.0 and 3.1 and PageMaker 4.2x. Copy the file into the **PPD Folder** located in the **Aldus Folder**, which is located in the **System Folder**.

Elite 12xx.PDF

This is the PostScript printer description file for QuarkXPress™ versions 3.1 or later. This file contains Elite 12ppm-specific information for paper sizes. Copy this file into the folder where the QuarkXPress application resides.

Elite 12xx.MPD

This extension is the PostScript printer description file for Ready,Set,Go!® versions 5.0 or later. Copy the file into the **MPD Folder** located in the **Ready,Set,Go! Folder**.

Selecting the LaserWriter 8 printer driver

The LaserWriter 8 driver shipped with the Elite 12ppm may look slightly different (presentation and layout of dialog boxes, menu items, etc.) from other versions of the LaserWriter 8 driver. However, the Elite 12ppm and the Elite 12ppm PPD files are compatible with all versions of LaserWriter 8.

Before you can print, you must select the LaserWriter 8 printer driver in the Chooser.

To select the LaserWriter 8 printer driver:

1. Choose the Chooser from the Apple () menu.

If you don't see the LaserWriter 8 icon in the upper-left area of the Chooser (1a), reinstall your printing software. If you don't see the name of your printer in the upper-right area of the Chooser (1c), refer to Chapter 6 in the *Elite 12ppm User's Manual*.

Note: If you use the Apple LaserWriter Utility to change the zone that the Elite 12ppm appears in, this won't take effect until you switch the printer off and then back on.

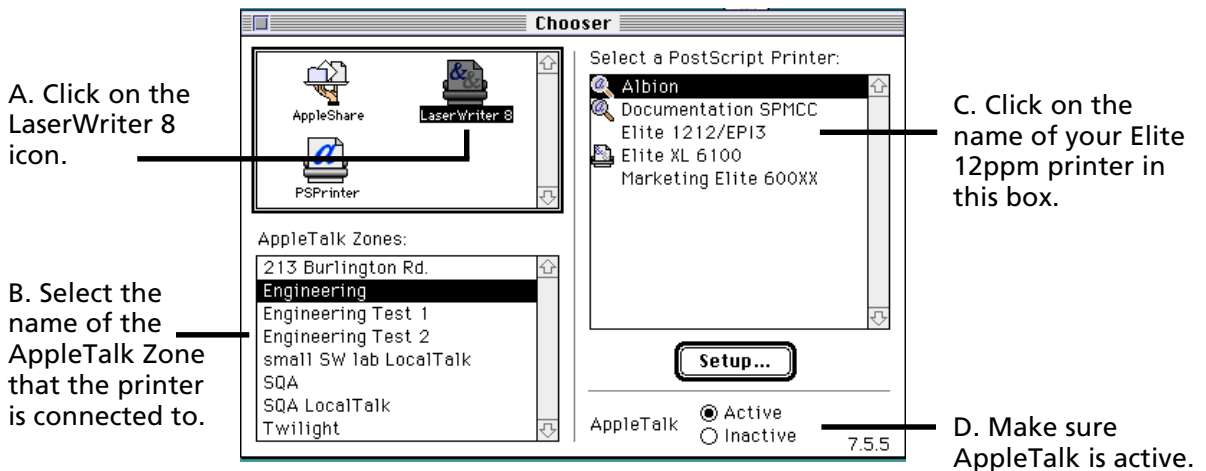

Selecting the printer description file

The LaserWriter 8 printer driver in your computer uses PostScript Printer Descriptions (PPDs). The Elite 12ppm PPD gives the Laserwriter driver information about capabilities common to every Elite 12ppm printer. This PPD is installed when you install the software from the Elite 12ppm CD-ROM. When you select the printer in the chooser, your computer communicates with the printer to get specific information about it. This can include memory amount, which paper trays are installed, and so on.



Creating the Printer Descriptions folder

When you install software from the Elite 12ppm CD-ROM, the Elite 12ppm PPD is copied into the **Printer Descriptions** folder. If a Printer Descriptions folder does not exist, the installer creates one and then copies the PPD into it. (For System 6, the Printer Descriptions folder is stored in the System Folder.)

Setting up the printer in the Chooser

You use the LaserWriter 8 Setup function in the Chooser to read the PostScript printer description files.

To select the PostScript Printer Description:

1. Choose the Chooser from the Apple () menu.
2. Click the LaserWriter 8 icon in the upper-left area of the Chooser. The name Elite 12ppm appears in the upper-right area of the Chooser below "Select a PostScript Printer." The name should appear highlighted; click the printer's name if it is not highlighted.
3. Click Setup (). A message box appears, informing you that the Macintosh is communicating with the Elite 12ppm. The LaserWriter 8 driver is automatically configured with specific information about your Elite 12ppm (model, memory, paper sizes, paper trays, etc.). After the process is finished, the Chooser reappears with an icon placed next to the Elite 12ppm name. Also, notice that "Setup" has an ellipsis (...) added to it – . The ellipsis indicates that "Setup" now contains user-selectable functions.

Setup options

Your printer is now correctly set up and you can print to it. However, if in the future you change something about it (like adding extra memory or new paper trays, for instance) you use the Setup dialog box. You can also use the Printer Info function to show you information about your printer.

To access the additional Setup functions:

1. Choose the *Chooser* from the Apple menu and select LaserWriter 8.
2. Select the name of the Elite 12ppm in the right scroll box.
3. Click Setup. The Setup dialog box appears.
 - Click *Auto Setup* to automatically reconfigure the printer driver after you have upgraded your printer with additional memory or additional paper trays. Normally, this will be all you need to do after making these changes.
 - Click *Select PPD* to manually select a PostScript Printer Description file.

- Click *Printer Info* to display information about the Elite 12ppm. Click the **Update** button to view the information about the Elite 12ppm currently selected.
- Click *Configure* to manually reconfigure the printer driver after you have upgraded your printer with new options. The available options for the Elite 12ppm are:
 - *Memory Configuration* – After installing additional memory, select the memory size range.
 - *Additional Tray* – After installing additional paper trays, select the option that corresponds to the new tray.
 - *Paper Sizes* – This pop-up menu enables you to select the page sizes that will be displayed in the Paper menu of the Page Setup dialog box.

Printing documents using the LaserWriter 8 printer driver

To print a document:

1. Open the document that you want to print.
2. Choose Page Setup from the File menu.
3. Make any selections in the Page Setup dialog box and click OK.
4. Choose Print from the File menu.
5. Make any selections in the Print dialog box and click OK.

Note: You may get error messages about insufficient disk space during printing. This is because your Startup disk does not contain enough free space. If the amount of free space on your Startup disk is insufficient, you will probably get other errors not specifically related to printing. The amount of free space you need is determined by the size and complexity of jobs that you print. If you do not get insufficient disk space messages, then you have enough free space.

When you print, the LaserWriter 8 driver makes a copy of the document before sending it to the Elite 12ppm. This copy is temporarily saved onto the Startup disk. If the Startup disk does not contain free space equal to the size of the document, you will get an error.

Selecting Page Setup options

Most applications have a Page Setup menu command. This allows you to control how a page will look. There is a pop-up menu at the top left of the dialog box which lets you change various items to do with page setup.

Page Attributes

Paper

You select paper sizes in the Paper pop-up menu. The default paper size is **US Letter Edge to Edge**. To change the paper size, click the Paper pop-up menu, drag the pointer to the paper size you want, and release the mouse button. If you click on the menu again, you'll see a check mark next to the current paper size. If you choose a paper size that is not edge to edge, anything closer than .35 inches (8.9 mm) from the edge of the paper will not print.

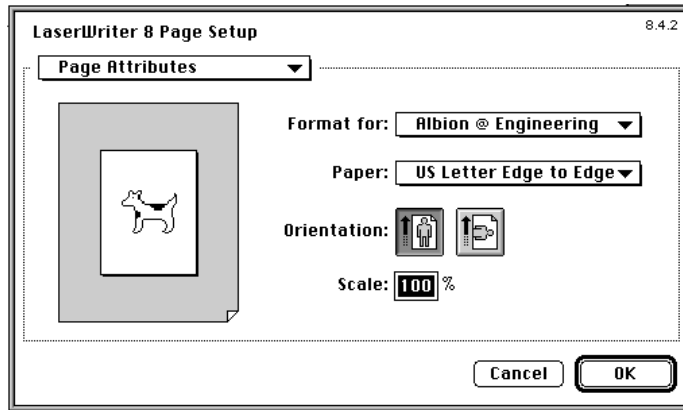

If you click on the “Dogcow” icon at the left of the dialog box, the icon will change to a list of paper and margin dimensions in inches. Click again to see the dimensions in centimeters.

Edge-to-edge printing

You can print edge-to-edge with all supported paper sizes. Print quality is not guaranteed within 4mm (0.16 inches) of each edge.

Orientation

You can change the orientation of the print on the page using the Orientation icons.

Scale

You can print the contents of a page from 25 to 400 percent of its normal size, using the Scale option. Enter a figure between these ranges (in 1 percent increments). The default is 100 percent, meaning there is no reduction or enlargement.

Options

If you choose PostScript Options from the Page Attributes pop-up menu, you'll see additional layout and formatting options. (Note: indicates an Elite 12ppm default setting.)

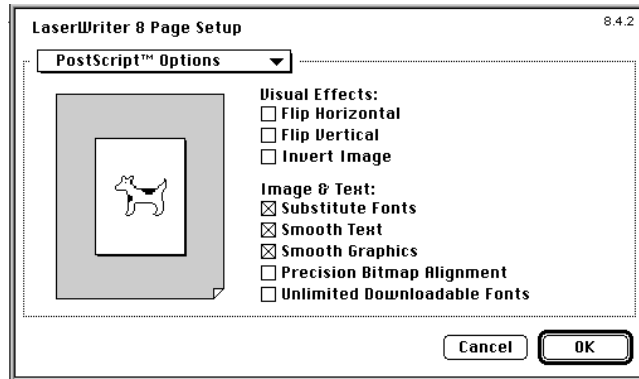

Visual Effects

You can manipulate the image on the page using the visual effects section. Your selections are graphically displayed in the image area in the left of the dialog box.

- Flip Horizontal flips your document horizontally.
- Flip Vertical flips your document vertically.
- Invert Image inverts the image of your document. Black changes to white and white changes to black.

Image and Text

- Substitute Fonts prints high quality resident fonts for certain screen fonts. When you select this checkbox, the following substitutions occur:

Times® for New York Helvetica® for Geneva Courier for Monaco

- Smooth Text smooths the edges of text derived from screen fonts.
- Smooth Graphics smooths the edges of bitmapped graphics.
- Precision Bitmap Alignment allows you to print bitmaps with less distortion, but the document will print at a slightly smaller size (1% to 4% depending on the printing resolution).
- If you check Unlimited Downloadable Fonts in a Document you can use as many downloadable fonts as you need in a document, but it may take longer to print.

Selecting Print options

When you select **Print** from the **File** menu, you see a dialog box offering you printing options. You'll also see the name of the printer at the top of the dialog box. When you click **Print**, you send the document to the Elite 12ppm. Clicking **Cancel** cancels the print job.

If you make changes in the Print dialog box, some of these changes stay in effect until you change them again. Others revert to the default settings the next time you print.

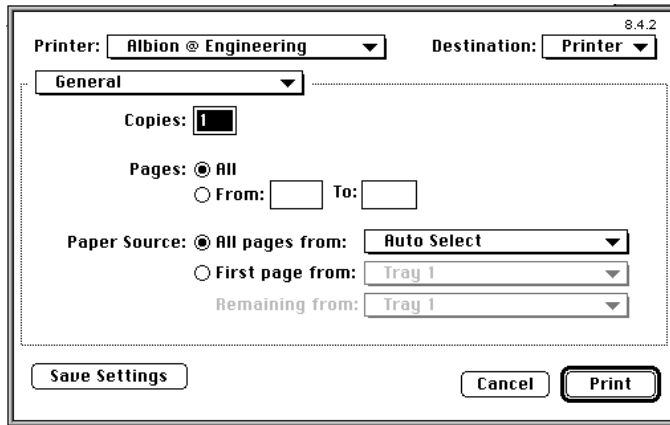

The pop-up menu named “General” gives you other options for printing.

Copies

Use the **Copies** option to specify the number of copies of the document to print, from 1 to 999. The default is 1 copy. To change the number of copies, click in the box and type the number of copies you want to print.

Pages

The **Pages** option default is **All**, which prints all the pages in the document, from first to last. **From** and **To** allow you to specify a range of pages to print. Click the button labeled **From** and type the page numbers of the range you want to print into the boxes (for example, From 9 and To 11 prints pages 9, 10 and 11).

Paper Source

The **Paper Source** pull-down menu lets you choose which paper trays supply paper to the printer. For instance, you may want to print a business letter where the first page is on letterhead and the remainder is on continuation sheets.

If you click on the **All** button, all pages will be fed from the source you select in the upper pop-up menu. When the **All** button is selected, the lower pop-up menu is dimmed. If you click on the **First from** button, this lets you choose which paper source is used for the first page of your document. When **First from** is selected, you can choose another paper source from the lower pop-up menu for the remaining pages.

- ✓ If you choose **Auto Select**, paper is drawn from the tray (in the case of multiple trays) that contains the paper size selected in the **Paper** option of the **Page Setup** dialog box. If no optional trays are installed, **Auto Select** has no effect and paper will be drawn from the internal tray.

- ✓ If you choose Tray 1, paper is drawn from the tray that is currently inserted in the Elite 12ppm's main housing.
- ✓ If you choose Tray 2, paper is drawn from this tray if the corresponding optional sheet feeder and cassette is installed.
- ✓ If you choose MPFeeder, paper is drawn from the multipurpose feeder.
- ✓ If you choose Manual Feed, this bypasses the normal paper sources of the printer so that you can place a single sheet of special paper or other media (e.g., transparency film) into the multipurpose feeder for printing.

Destination

The Destination pop-up menu lets you to send your document to the printer or save it to a file.

Background Printing

This allows you to choose whether your documents print in the foreground or background. Foreground printing means that your Mac cannot be used until the last page is printed.

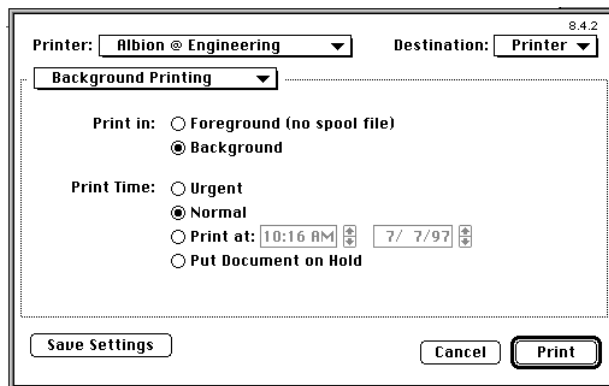

Background printing (recommended) stores the print file on your hard disk and sends it from there to the printer. This method is slightly slower than foreground printing, but it lets you use your computer before printing is completed.

You can also control the time when your job is printed.

Cover Page

If several people share your printer on a network, you may find that printing a cover page lets you identify the beginning and end of your print job from a stack of jobs in the output tray.

If you select Cover Page, an extra page (identifying the document) is printed. The cover page contains: the user name, as specified in the Chooser; the name of the document, if

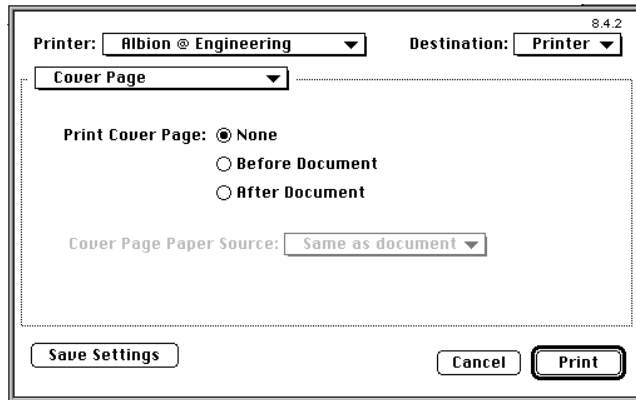

there is one; and the date and time the document was printed. If you choose the **None** option, no cover page is printed. If you choose either **Before** or **After Document**, a cover page will print in the appropriate position.

Color Matching

The Color Matching pop-up menu allows you to specify grayscale or black and white printing.

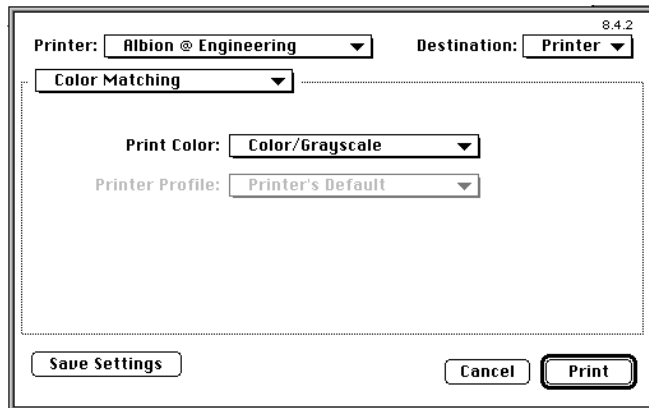

- ✓ If you choose Black and White, you get black and white output (no shades of gray). Darker areas are converted to black, and lighter areas are converted to white.
- ✓ If you choose Color/Grayscale, you get grayscale output. Color images have colors substituted by gray shades.
- ✓ If you choose Color Matching, you get grayscale output that uses the advanced color matching capabilities of ColorSync or PostScript Level 2 to match the color and gray tones on the computer screen as closely as possible.

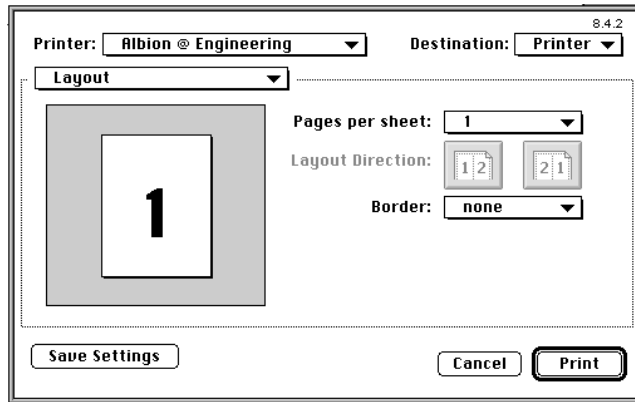

Layout

This option lets you print 1, 2, 4, 6, 9, or 16 pages on a sheet and resizes the images to fit. It also lets you choose a border to use between pages on a sheet.

Error Handling

The Error Handling dialog box allows you to specify how any PostScript errors are reported during printing.

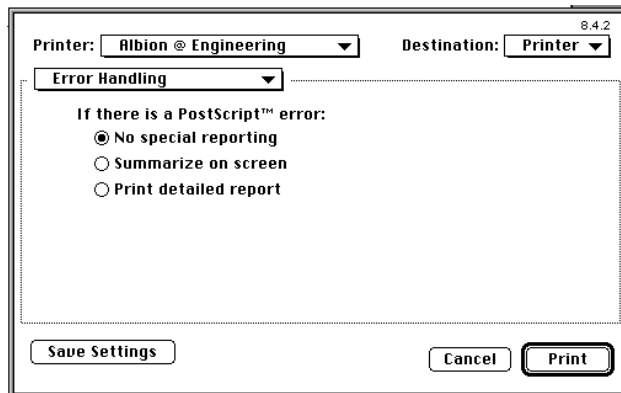

- ✓ If you choose No Special Reporting, no PostScript error reports are produced.
- ✓ If you choose Summarize on Screen, you'll see a message describing any PostScript errors on the monitor. This option does not work when Background Printing is on.
- ✓ If you choose Print Detailed Report, you'll get a printed report describing any PostScript errors.

Save as File

This dialog box (not shown) lets you select options for print jobs that you save to the hard disk as files.

Printer Specific Options

You can choose the output resolution (in dots per inch) for the current print job. This overrides the default resolution that was specified in the printer's control panel using the Resolution submenu.

You can also choose to enable (recommended) or disable AccuGray. AccuGray is GCC's technology to control the tendency of laser images to print darker than expected.

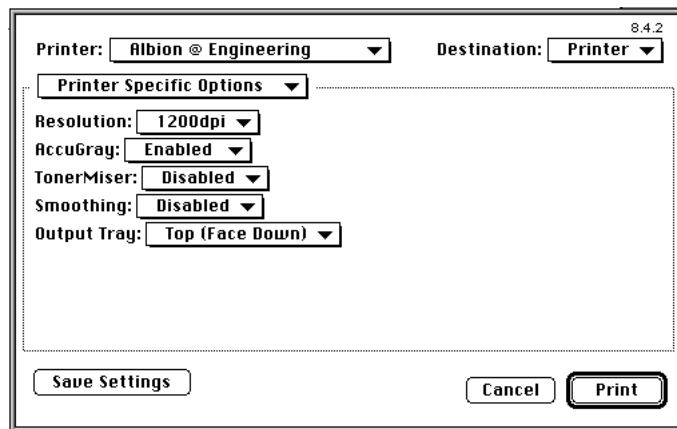

Save

If you find that you're often changing the Printer's Default options, you can save your settings by clicking the Save Settings button. Your saved settings will carry over to any application that uses these LaserWriter 8 menus.

Manual feed printing

The LaserWriter 8 driver supports manual feed printing.

When you want to manually feed paper, envelopes, or transparencies into the printer:

1. Choose Print from the computer's File menu.
2. Choose Manual Feed from the Paper Source pop-up menu.

3. Click the Print button.

The message, **Manual Feed**, appears in the printer's control panel display to indicate that the printer is ready for you to insert the paper. The control panel display also indicates the paper size and orientation.

4. On the printer, open and extend the multipurpose feeder.
5. Adjust the paper guides on the multipurpose feeder for the size of the paper that you are using.
6. Insert the paper into the multipurpose feeder. (Insert letterhead face up, with the top of the page entering the printer first. Insert envelopes with the flap down and the top edge on the right as you face the front of the printer.)
7. Press the Manual Feed key on the control panel.

Note: If you realize that you want to use paper in the internal paper tray, do not insert paper into the multipurpose feeder, and press the **Form Feed/Continue** key on the control panel. If you insert paper into the Multipurpose feeder and you do not press the **Manual Feed** key within the Manual Feed Timeout period, the job will be canceled. The default Manual Feed Timeout period is five minutes, and you can change this through the printer's control panel menus to be in the range from 30 seconds to ten minutes.

Naming the Elite 12ppm

You must assign each printer a unique name if there is more than one Elite 12ppm on the network. If you don't assign a unique name to each printer, a number is automatically added to duplicate names to distinguish the printers from one another.

Note: If you change the name of a printer on the network system, every user on the network system must select the new printer name in the Chooser.

If you want to name the Elite 12ppm:

1. Select the Elite 12ppm in the Chooser. Click the LaserWriter 8 icon in the left scroll box and click the name of the printer in the "Select a LaserWriter" scroll box.
2. Double-click the LaserWriter Utility icon. (The LaserWriter Utility is located on the startup disk in the Elite™ 12ppm Folder.) You'll see the LaserWriter Utility, with four menus in the menu bar.
3. Choose Name Printer from the Utilities menu. The "Rename the chosen printer" dialog box appears displaying the current name of the printer.

4. Type the new name of the printer in the space provided. Names must be at least two characters in length, but no more than 31 characters. Names cannot contain a colon (:), an asterisk (*), or parentheses.
5. Click Rename.
6. Choose Quit from the File menu.

4: Using Windows 3.1

Overview

You set up your Windows or DOS computer to use the Elite 12ppm by installing the Elite 12ppm software for PC-compatibles. This software is on this CD-ROM. It includes customized Windows PostScript printer drivers for Windows 3.1 (and Windows for Workgroups 3.11), Windows 95 and Windows NT 3.51 and 4.0. It also has printer description files that let you use all the printing and paper handling features of the Elite 12ppm.

This and the following sections detail installation and printing instructions for Windows 3.1, Windows 95, Windows NT 3.51, Windows NT 4.0, and DOS. Information on networking printers with Windows is in the Networking section of this manual.

Important: Read the release notes contained in the README.TXT file before installing the printing software. This file includes important last-minute feature and compatibility information about the Elite 12ppm.

Printing with Windows 3.1

If you want to install the GCC Windows 3.1 PostScript driver:

1. Switch on the PC.
2. Start Windows.
3. Double-click the Main group from the Program Manager window. You'll see the Main group window.
4. Double-click the Control Panel icon. You'll see the Control Panel window.
5. Double-click the Printers icon. You'll see the "Printers" dialog box.
6. Click the Add button.
7. The dialog box expands, and shows you a list of printer drivers in the "List of Printers" list box. These are the printer drivers that came on the disks you received with your Windows software. Select Install Unlisted or Updated Printer and click the Install button.

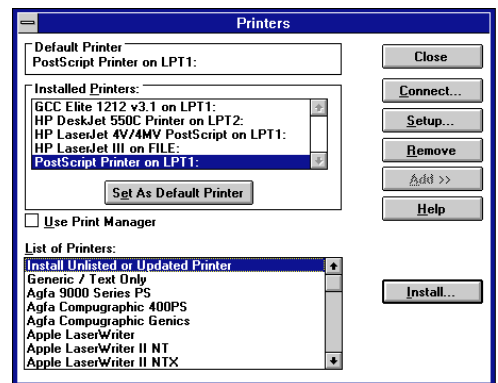

8. The “Install Driver” dialog box appears displaying the message, “Insert unlisted, updated, or vendor-provided printer driver disk in:” along with the A:\ or B:\ prompt. Change the A:\ or B:\ to the letter of your CD-ROM drive (for example, to D:\). Add the directory WIN31 so that the prompt reads D:\WIN31, for example.



9. Insert the Elite 12ppm CD-ROM into the CD drive and click OK in the dialog box. You’ll see the “Add Unlisted or Updated Printer” dialog box with a list of Elite 12ppm printer drivers. Select a driver and click OK.

10. You’ll see the “Printers” dialog box. Select the driver for your Elite 12ppm model.

11. After the driver is installed, you’ll see the “Printers” dialog box again. GCC Elite 12ppm appears in the “Installed Printers” list box with LPT1 (which is the first parallel port) designated as the default port. Select the GCC Elite 12ppm printer driver in the “Installed Printers” list box and click Set As Default Printer. The Elite 12ppm is now set as the default printer and will appear in the “Default Printer” area of the “Printer” dialog box.

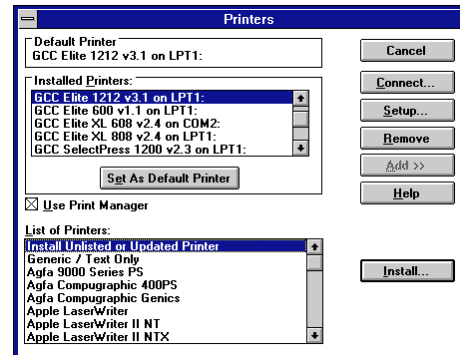

Choose Use Print Manager to enable print spooling. With print spooling, you have the full use of your computer after you press the Print button rather than waiting until the print job is completed. This option allows your documents to print in the background. Background printing is useful when printing large or multiple documents, but documents do not print quite as fast.

12. Click Close, unless you want to change printer options (see the next section, “Setting Windows 3.1 Printer Options”).

You can now print from your computer to the Elite 12ppm.

You may also need to install printer description files if you use certain applications that require them. Go to the section “Installing printer description files.”

Setting Windows 3.1 printing options

Now you have installed the printer software in Windows, there are a number of settings that you may need to change if you have special printing requirements. Most users do not need to change these settings.

If you want to change print options:

1. Click Setup in the "Printers" dialog box. You'll see the Setup dialog box.

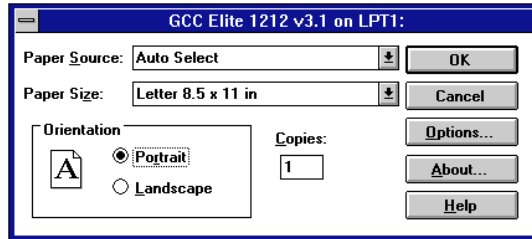

Paper Source

You choose which paper tray supplies the printer from the Paper Source drop-down menu.

- If you choose Auto Select, the printer selects the paper tray that holds the paper size selected in the Paper option of the Page Setup dialog box. This option only works if you have more than one paper tray.
- If you choose Tray 1, the printer uses paper from the Elite 12ppm's main tray.
- If you choose Tray 2, the printer uses paper from the lower tray (if this extra tray is installed).
- If you choose Manual Feed, the printer waits for you to place paper or other media (transparency film, for example) in the multipurpose feeder. When you have done this, you must press the Manual Feed key on the printer's control panel to draw the paper into the printer.
- If you choose MPFeeder, the printer uses paper from the multipurpose feeder. Unlike the Manual Feed option, the printer doesn't require you to press the Manual Feed button on the control panel, but you must have paper ready in the Multipurpose feeder.

Paper Size

If you want to change the paper size, click the Paper Size drop-down menu, and choose the paper size.

Edge-to-edge printing

The Elite 12ppm will print edge-to-edge on all supported paper sizes except Letter Small and A4 Small. However, print quality is not guaranteed within 4mm of each edge.

Orientation

Use this option to change the position of the image on the page. If you choose vertical, or **Portrait**, this prints the image upright on the page. If you choose horizontal, or **Landscape**, this prints the image sideways on the page. The default is **Portrait**.

Note: If you create a document and specify in the application's page setup that it should be vertical, then if you choose Landscape in this dialog box the image will be cut off at the bottom.

Copies

If you want to print more than one copy, enter the figure here. The maximum number of copies is 999.

Options

To make further changes, click on the **Options** button. You'll see the Setup Options dialog box.

- Print to ...

If you choose Print To Encapsulated PostScript File, the document is not printed but is saved in the location you specify as an (EPS) file. You may need to do this if you send files to a service bureau or want to make a page into a graphics file.

- Scaling % ...

If you change the Scaling figure from the default 100 percent, the image is reduced or enlarged on a page. If you select 50 percent, the image prints at half size; if you select 200 percent, the image prints at double size.

Note: We recommend that you use the application's Scaling option and leave the figure in the Print Options dialog box at 100 percent, unless an application does not support scaling. If you set *both* this dialog box and the application's Print dialog box to scaling percentages other than 100 percent, you'll get unpredictable results.

- Margins ...

If you choose Default Margins, certain applications will be limited to placing page elements (i.e., text and graphics) within the page's margins. This is only important if you are using Letter Small or A4 Small paper sizes, since the other sizes are all edge-to-edge and thus have no margins. Letter Small and A4 Small have margins of .35 inches (9 mm) all around.

If you select Default, the printer will tell your applications that these margins exist on Letter Small and A4 Small. If you select None, your applications will be told that there are no margins. However, the printer will not reproduce any text or graphics in the margin area.

- Send Header ...

If you choose Send Header, a PostScript header will be sent at the beginning of each print job you send to the printer. This is especially useful if you are printing to a networked printer.

- Smoothing ...

Select either printer's default, enabled or disabled. If you select the printer's default option, the Elite 1212 default (either enabled or disabled) will be used. If you enable smoothing here, Windows 3.1 will smooth text and graphics.

Advanced Options

To make more changes, click **Advanced** to see the Advanced Options dialog box.

- You can set a default resolution for this computer by choosing the output resolution (in dots per inch) from the Resolution menu. The resolution you select overrides the resolution selected in the printer's front panel Default Resolution submenu.

You may have a computer on a network that is used for work which can be printed at lower resolutions than the maximum. For instance, spreadsheets and internal documents can usually be printed satisfactorily at 300 dots per inch. You can set the resolution in the Advanced Options dialog box and override this as necessary in an application's Page Setup or Print dialog boxes.

- You need to change the Virtual Memory setting when you add RAM to the printer or if you routinely download fonts to the printer's memory. The figure sets the amount of virtual memory that will be available for printing. The amount of memory that can be allocated depends on the amount of RAM installed in the printer.

Full instructions on how to change this figure are included in the Adding RAM section of the Elite 12ppm CD-ROM.

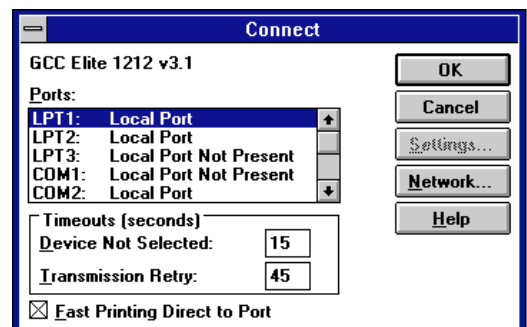

Port assignment – Windows 3.1

You may need to change the port used by your PC; your PC's LPT1 may be used by another

device or you may wish to use a serial port. (GCC recommends that you use one of the LPT [parallel] ports, because they are considerably faster than a serial port.)

If you want to change the port assignment:

1. In the Printers dialog box, select the GCC Elite 12ppm printer driver in the "Installed Printers" list box (if it is not already selected).
2. Click Connect. You'll see the Connect dialog box.
3. Select the new printer port assignment in the "Ports" list box. If the printer is connected to a parallel interface, select one of the parallel ports (labeled LPT1, LPT2, etc.). If the printer is connected to a serial interface, select one of the serial ports (labeled COM1, COM2, etc.).
4. If you use a serial connection (as shown in step 3), click the Settings button. (The Settings button is dimmed if the Elite 12ppm is connected via a parallel interface.)
5. You'll see the "Settings" dialog box, displaying the PC's serial port default parameters. Use the following: 19,200 Baud Rate, 8 Data Bits, None for Parity, 1 Stop Bit, and Hardware for Flow Control.

Note: The Elite 12ppm Windows driver is shipped with the baud rate set to 9600. If you change the baud rate to 19,200, you will also need to change the baud rate in the RS-422 Baud Rate submenu in the printer's front panel to 19,200. Also, some versions of DOS do not support 19,200 baud rate. If you frequently print from one of these versions of DOS, leave the Windows serial port baud rate at 9600 to prevent communication problems.

6. You now need to verify the serial port settings, if the Elite 12ppm is connected via its serial interface. Verify that the printer's control panel serial port settings match those set in the Windows "Settings" dialog box. Note that the Hardware Flow Control setting in Windows corresponds to the DTR Flow Control setting on the Elite 12ppm control panel.
7. Click OK to save the settings and return to the "Connect" dialog box.
8. Click OK to close the "Connect" dialog box.
9. Click Close to close the "Printers" dialog box.
10. Choose Close from the Control menu to close the Control Panel window.
11. Choose Close from the Control menu to close the Main window.

Installing printer description files

Printer description files (file names with the following extensions: .PDF, .PDX, or .PPD) are files that allow you to use Elite 12ppm-specific features from within specific applications. Please refer to the documentation included with the application for more information on where to copy these files and how to use them.

To install printer description files:

1. Insert the Elite 12ppm CD-ROM into your CD-ROM drive.
2. At the root directory (C:\), type the following command and path name for the application you are using and press the Enter key. (Note: Depending on where you have installed any of these applications, the path names may be different).

- **Adobe Illustrator 4.0 or 4.1:**

Type `copy d:*.ppd c:\ai4\ppd` to install the PPD file.

- **Adobe PageMaker 6.0:**

Type `copy d:*.ppd c:\pm6\rsrc\usenglish\ppd4\` to install the PPD file.

- **Aldus FreeHand 4.0 or PageMaker 5.0:**

Type `copy d:*.ppd c:\aldus\usenglish\ppd4` to install the PPD file.

- **Aldus FreeHand 3.1 and earlier:**

Type `copy d:\ppd3*.* c:\aldus\usenglish\ppds` to install the PPD and PDX files.

- **Macromedia FreeHand 5.0:**

Type `copy d:*.ppd c:\fh5\usenglish\ppd` to install the PPD file.

- **QuarkXPress:**

Type `copy d:*.pdf c:\xpress` to install the PDF file.

Printing from Windows 3.1 applications

The Elite 12ppm is designed to work with all Windows 3.1 (or higher) compatible applications. The GCC Windows driver provides commonly used printing options, along with options specific to the Elite 12ppm.

The location of printing options can vary among Windows applications, and certain options may be accessible from more than one dialog box. Options may also have different names than those in the Printers control panel (e.g., print quality vs. resolution). Refer to the application's documentation for more information.

Selecting Print Setup options

The Print Setup option is usually located under the File menu. The following Print Setup dialog box example is taken from Microsoft Write.

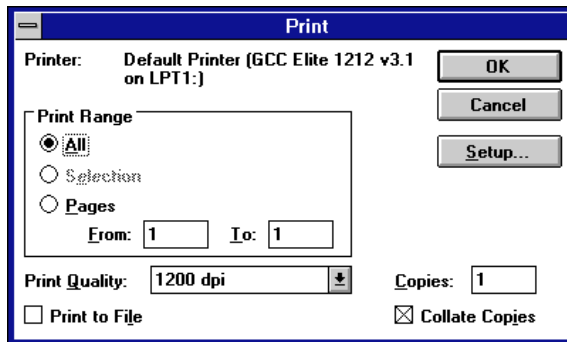

Note: Applications use different terminology to refer to the Print Setup dialog box. For example, Microsoft Word® uses **Print Setup** and Adobe PageMaker uses **Target Printer** or **Print** (depending on the version). These commands are usually found on an application's File menu; for more information, refer to the documentation provided with the application you are using.

Selecting Print options

The Print option is usually located under the File menu. The following print dialog box example is taken from Microsoft Write.

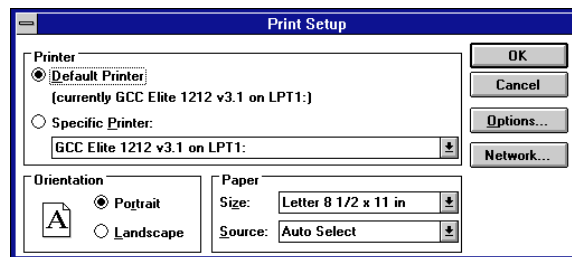

Print Range

The Print Range option default is All, which prints all the pages in the document, from first to last. **From** and **To** allow you to specify a range of pages to print. Click in the box labeled **From** and type the first page number of the range you want to print. Then click in the box labeled **To** and type the last number of the range. The Print Range option is the only option which cannot be set through the Print Manager or Printers control panel.

Print Quality

The Print Quality option is identical to the Resolution option found in the Advanced Options dialog box. The resolution selected in this menu will override the resolution

selected in the Print Manager and/or the printer's front panel Default Resolution submenu. After you have made your selection in the Print dialog box you can click OK to print your document or Cancel to close the dialog box.

Print to file

The Print to File option allows you to save your document to a PostScript file. This file can then be sent to the printer with the DOS COPY command. If your application does not have a Print to File option you can still print to a file by selecting the File: option available from the Ports list box in the "Connect" dialog box. Refer to Windows Help for more information.

5: Using Windows 95

Windows 95 printing software overview

You set up your Windows 95 computer to use the Elite 12ppm by installing the Elite 12ppm software for Windows 95. This software is on the Elite 12ppm CD-ROM.

Windows 95 uses a Wizard to help you install printer software. A Wizard is a series of dialog boxes. In each dialog box you make configuration choices then click the Next button to move to the next dialog box.

Part of the software that you need is contained on the Windows 95 CD-ROM or floppy disks. Make sure you have the disk(s). If you cannot locate the disk(s) or your computer was not supplied with them, follow the special instructions when you reach step 15.

Plug and Play installation

You can install the Elite 12ppm software on your computer using Plug and Play. This will work if you are installing the software on the computer which is connected to the printer through the parallel port.

If the printer is not connected to the computer through the parallel port, go to the section "Using Add Printer" below.

To use Plug and Play to install the software on the computer, connect the parallel port of the computer to the parallel port interface on the printer using an IEEE-1284 parallel cable (it will be stamped "1284"). Turn on the printer and place paper in the paper tray. Then:

1. Start the computer if it is not turned on, or go to Shut Down on the Windows 95 Start menu and choose "Restart the computer."
2. The computer will go through the normal startup procedures and then show a dialog box telling you that it has found new hardware.
3. You'll then see a dialog box which asks you to select which driver you want to install. Choose the option "Driver from disk provided by hardware manufacturer" and click OK.
4. Go to step 8 of the numbered steps in the "Using Add Printer" section.

Using Add Printer

To install the printing software without using Plug and Play, make sure that the printer is switched on, has paper, and is connected to the computer or network.

To install the printing software, make sure that the printer is switched on, has paper, and is connected to the computer or network. Then:

1. Click on the Start button in Windows 95.
2. You'll see the Start menu. Click on Settings, then click on Printers on the submenu.
3. You'll see the Printers folder. Double-click the Add Printer icon.
4. You'll see the first screen of the Add Printer Wizard dialog box. Click the Next button at the bottom of the dialog box. If you see a list of printer manufacturers and printer models, go to step 7. Otherwise, you'll see the local/network dialog box.

- Choose a connection:

- Select Local if your printer is attached directly to your computer, even if you may intend others to use it through a network.

- Select Network only if your printer is *not* attached directly to your computer.

- If you selected Local, click Next and go to step 7. If you selected Network, click Next and go to the next step.

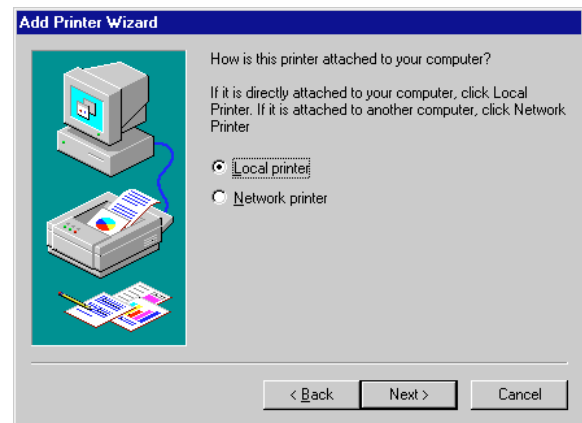

5. You'll see the network path dialog.

- Type in the path or queue name of the printer. You can click Browse to display a visual representation of your site's network and the printer's location on it.

- Click the Yes radio button if you print from MS-DOS based programs.

If you selected No for the MS-DOS printing question, click Next and go to step 7. If you selected Yes, click Next and go to the next step.

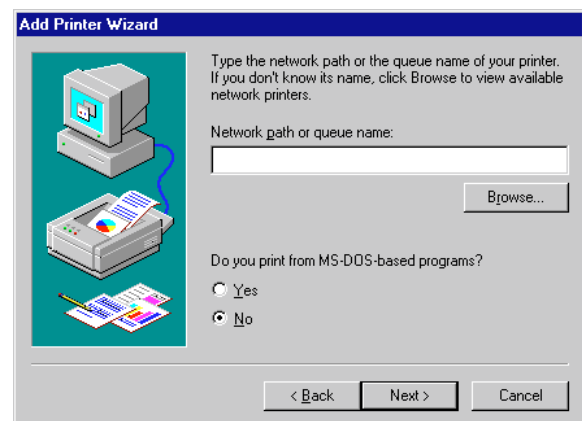

6. You'll see a dialog box that lets you print from MS-DOS applications to a network printer. Click the Capture Printer Port button and select an appropriate LPT port and print queue. Click OK.
 - Click Next.



7. You'll see the manufacturer/model selection dialog box.

This dialog box contains lists of printer manufacturers and their printer models.

- Ignore the settings in the boxes, and click the Have Disk button.

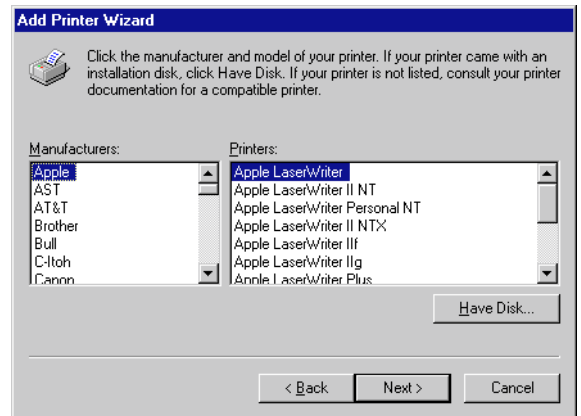

8. You'll see the Install From Disk dialog box.

- Change the drive letter in the box at the bottom of the dialog box to the drive letter of your CD-ROM drive.

9. Put the Elite 12ppm CD-ROM into the CD-ROM drive of your computer, wait for a few seconds, then click the OK button.

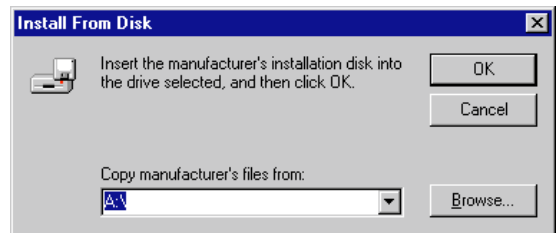

10. You'll see a dialog box with the names of one or more Elite 12ppm printers.
 - Select your Elite 12ppm printer model from the list.

If you selected Network in step 4, click Next and go to step 14. If you selected Local, click Next to go to the next step.

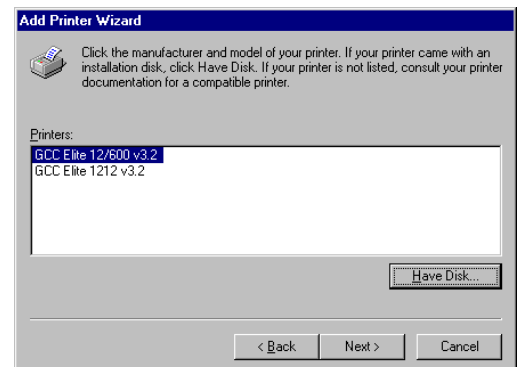

11. You'll see the port selection dialog box.

GCC printers can accept jobs from either an LPT (Parallel) port or a COM (Serial) port. We recommend that you use a parallel port (LPT) wherever possible.

- Choose a port, then click Configure Port.

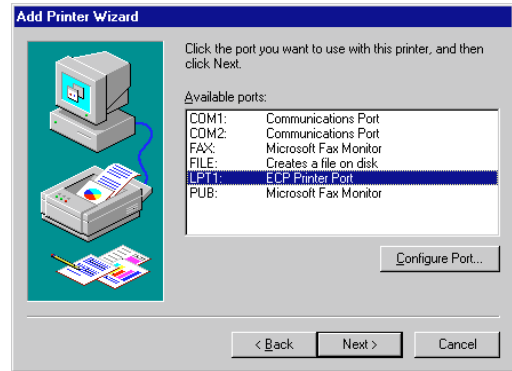

12. You'll see a configuration window, specific to the type of port you chose (LPT or COM).

This is what you'll see if you chose an LPT port. We recommend that you check all available check boxes.

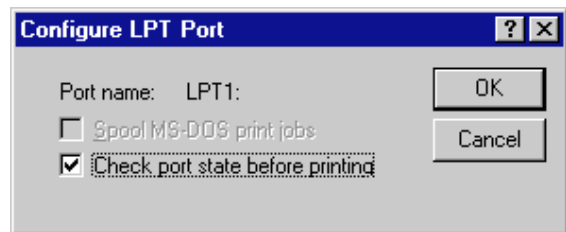

This is what you'll see if you chose a COM port. We recommend that you use these settings.

Note: The serial port settings in the printer's control panel menus must match the settings in this dialog box. Check the settings and change them if necessary. The serial port's Baud Rate submenu corresponds to the Bits per second drop-down list box in the dialog box. The DTR setting in the Flow Control submenu is the same as the Hardware setting in the dialog box.

- Click OK.

13. You'll see the port selection dialog box again.

- Click Next.

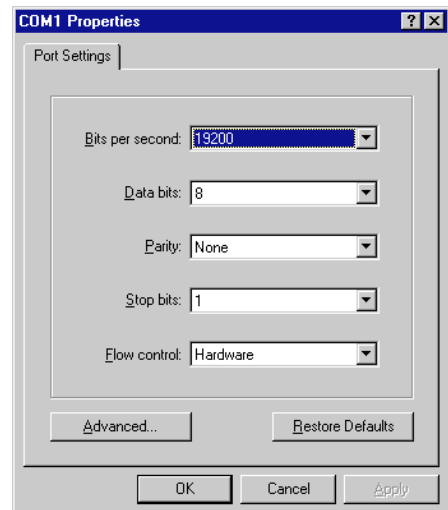

14. You'll see the name printer dialog box.

- You can enter a new name for your printer if you wish, or you can leave the default name. Also, at this point you should decide whether you want to make this the default printer. If you say Yes, the Elite 12ppm will be the printer selected every time you print from a Windows application.
- Click Next.

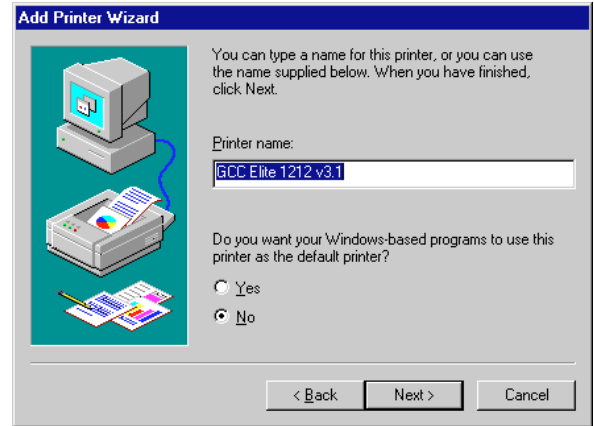

15. You'll see the Print a Test Page dialog.

- Change the setting to No. Because you have to make changes after the software is installed, we recommend that you don't choose to print a test page yet. You'll print a test page when the installation is complete.
- Have your Windows 95 CD or disks ready, and click Finish.

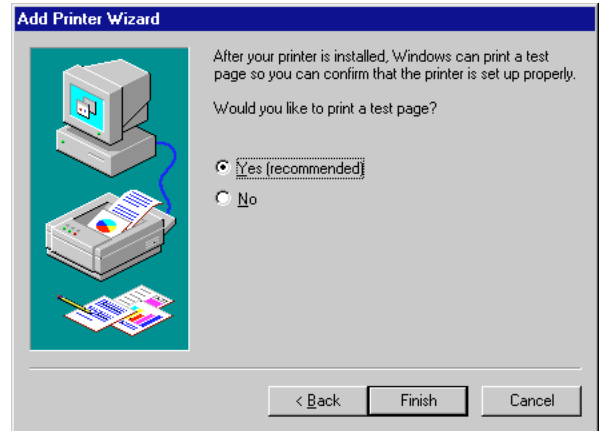

- The software installation will now commence. At one point, a dialog box will ask you to insert either the Windows 95 CD-ROM or the Windows 95 floppy disk that contains the printer driver. The kind of disk you need depends on whether Windows 95 was originally installed with a CD or floppy disks.

- If you are prompted to insert a CD, remove the Elite 12ppm CD-ROM, insert the Windows 95 CD, and click OK.

- If you are prompted to insert a floppy disk, insert the appropriate Windows 95 floppy disk into the drive and click OK.

If you do not have Windows 95 on disk, or the installation process halts because a file cannot be found, go to the section "Solutions to possible software installation problems" immediately after these numbered steps.

16. When the installation is complete, you'll see the Printers folder, including an icon for the newly installed printer.

- Using the right mouse button, click on the printer's icon. Select Properties from the pop-up menu.

17. You'll see the printer's Properties dialog box.

- The next steps are for network printers only. If you connected your printer using the parallel port go to step 21.

18. Click the Capture Settings tab at the top of the dialog box.

19. You'll see the Capture Settings panel. Deselect all the checkboxes, as shown.

20. Click Apply.

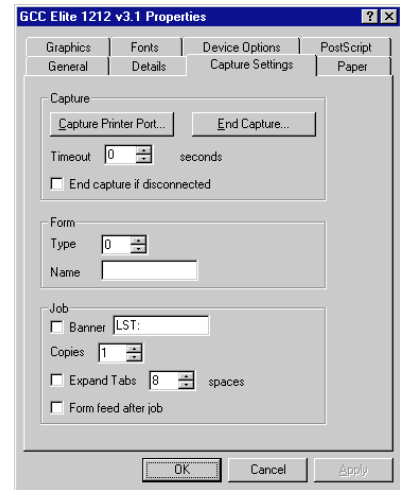

21. Click on the General tab at the top of the dialog box.

22. Click Print Test Page.

The test page will be formatted and a message box will appear asking you if the test page printed successfully. If the test page printed (this may take a minute), click Yes.

If the test page does not print, check that the printer is turned on and does not show an error message in its control panel. Make sure there is paper in the printer and all cables are properly connected. If there is still a problem, click No in the message box. Windows 95 will display troubleshooting steps.

If your page printed correctly, you've completed the normal installation process. You may need to install printer description files if your applications need them. Read the section "Installing printer description files" later in this chapter.

A few users may have special printing requirements; for instance, they may have added extra paper trays or more memory to their printer, or want the default resolution or paper

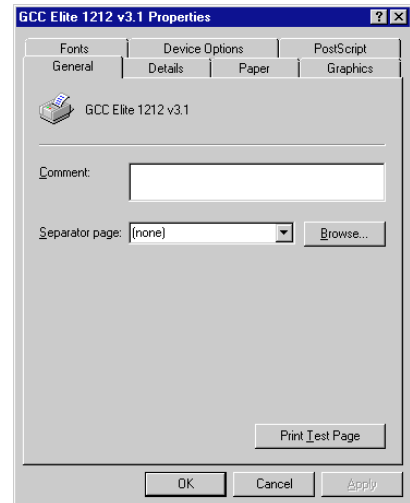

size to be different from the factory default settings. Read the section “Exploring the Properties dialog box” later in this chapter.

The next section, “Solutions to possible software installation problems,” refers only to problems users may encounter in step 15 of the installation process. If you completed step 15 without problems this section does not apply to you.

If none of these situations applies to you, you’ve completed installing the printer software on this computer. Install the software on any other computers that will use the printer, and the printer is ready to use.

Solutions to possible software installation problems

In some cases you may not be able to complete the software installation process when you click the Finish button in step 15. Normally, the program stops and asks you to insert a Windows 95 floppy disk or the CD-ROM. Once you have removed the Elite 12ppm CD-ROM (if necessary) and inserted the Windows 95 disk, the program continues and the installation is complete.

Two things may prevent this:

- You may have a Windows 95 computer that was not supplied with the program on floppy disks or CD-ROM.
- In some cases you may find that after you have inserted the Windows 95 CD-ROM in the drive and clicked OK, the printer installation does not continue and you’re prompted to insert the Windows 95 CD-ROM again.

The installation process requires you to install files that are found on the Windows 95 CD-ROM or disks. Some versions of the Windows 95 CD-ROM have these files in different places than others, and you have to show the install program where these files are located.

If you use the original Windows CD-ROM that came with your computer this problem should not arise.

If you do not have Windows 95 on disk or CD-ROM, continue the installation in this way:

1. Click on the Browse button at the bottom right of the Copying Files dialog box.

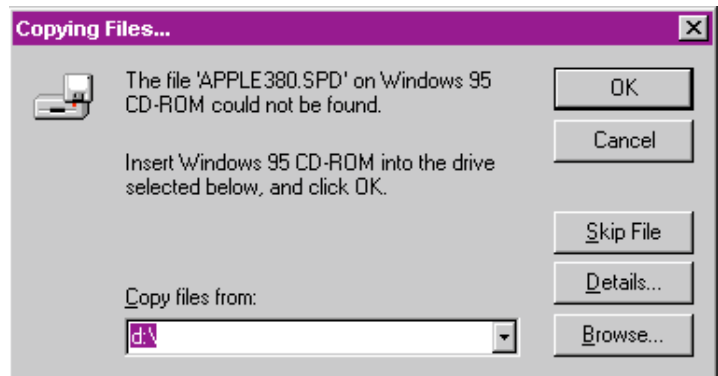

2. In the Open dialog box, choose drive C in the Drives window at the bottom center.

3. In the Folders list, scroll down till you see the windows folder.

4. Click on the folder name "windows" then click OK.

5. In the Folders list, scroll down until you see the options folder.

6. Click on the folder name "options" then click OK.

7. Click on the folder name "cabs."

8. Click OK to accept this folder. You'll see a file name similar to win95_15.cab.

9. Click OK again to accept this file name.

10. Click OK in the Copying Files dialog box.

11. The installation will continue. Go back to step 16 in the installation instructions.

If you have a Windows 95 CD-ROM and the installation still does not continue, you'll see the Copying Files dialog box again.

Make sure that you have the Windows 95 CD-ROM in the drive and continue the installation:

1. Click on the Browse button at the bottom right of the Copying Files dialog box.

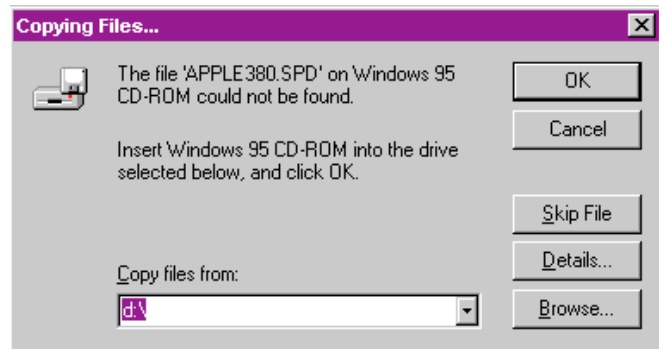

2. In the Open dialog box, scroll down the list of folders in the center pane until you see a folder called win95.

3. Click on the folder name win95.

4. Click OK to accept this folder. You'll see a file name similar to win95_15.cab.

5. Click OK again to accept this file name.

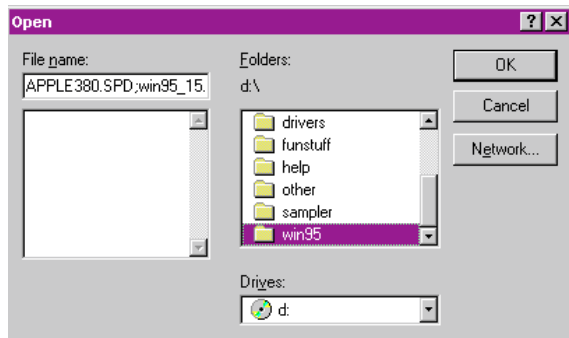
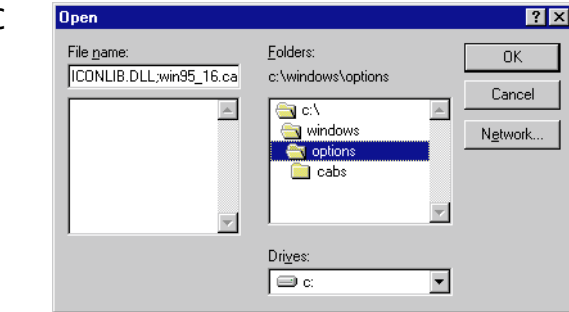

6. Click OK in the Copying Files dialog box.
7. The installation will continue. Go back to step 16 in the installation instructions.

Exploring the Properties dialog box

Now that you have installed the printing software in Windows 95, there are a number of settings that you may need to change if you have special printing requirements. Most users will not need to make any changes here.

Most of the Properties dialog box contains options that are the same for all printers using Windows 95, so this section of this installation guide only covers the options provided by GCC. If you want information on options for all Windows 95 printers, please refer to the Windows 95 on-line help system and Windows 95 documentation.

The changes you make in the Properties dialog box affect all applications, but on this computer only.

If you don't already have the Properties dialog box displayed:

1. Click on the Start button. You'll see the Start menu.
2. Choose Settings, then choose Printers from the submenu that appears.
3. You'll see the Printers window. Use the right mouse button to click on the Elite 12ppm icon, and choose Properties from the pop-up menu.

The Properties dialog box has tabs across the top. Click on the tabs to see other *pages*. Each page has options to configure your printer.

If you configured your printer as a local printer, you'll see a tab called Sharing. If you configured your printer as a network printer, the Sharing tab is replaced by a Capture Settings tab. Otherwise the tabs are the same.

You use Sharing if you want to share your printer and files over a network. This page of the dialog box is the same on all Windows 95 computers; further details can be found in the Windows 95 on-line help and documentation.

If you configured the printer for a network, you've already made the necessary changes to the Capture Settings page.

The Device Options page

Click on the Device Options tab to see the Device Options page. This page contains settings specific to your GCC printer model.

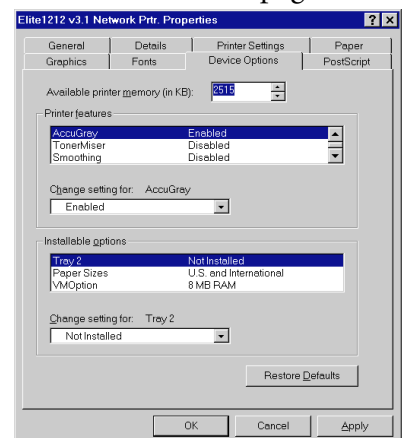

Printer features

In the Printer features box you'll see options specific to your printer. If you want to change the current setting of any feature, click on its name in the upper box. You'll see settings in the "Change setting for" drop-down list box below. Click on the setting you want.

Note: The features you see in the list may vary between printer models.

Installable options

If you add options (like more paper trays or extra printer RAM), you need to change the Installable options list. After you have changed this option, Print dialog boxes in this computer's applications will show extra paper trays, for example.

Note on VMOption: The VMOption selection corresponds to the amount of RAM installed in the printer. If you add or subtract printer memory, you will need to change the amount shown under VMOption. If memory was added to your printer before you installed the Windows 95 printer software, you will need to change the VMOption amount.

If you have to change the printer memory size, click on VMOption and select the correct memory size from the drop-down list box. Answer Yes to the question about available printer memory. Also, see the following section on upgrading printer memory.

Updating printer memory

If you install additional memory in your printer, you must update the printer driver. You do this by adjusting the Available printer memory setting at the top of the Device Options page. When the Available printer memory figure is correct, your computer will send files that print faster.

If you routinely download more than one or two fonts to the printer's memory, you should also update your Available printer memory, even if you have not added any extra memory to the printer. Download your normal font set and then update the memory.

If you want to update the printer driver, you first have to copy a file to the printer, using a DOS window (do not use Windows 95's Print command). This prints a page that tells you the maximum suggested virtual memory for the printer. You then enter the figure in this dialog box.

1. Copy the file TESTPS.TXT to the printer. This file is included with Windows 95.
 - Click on the Start button, then choose Programs from the Start menu. Click on MS-DOS Prompt in the program list; you'll see a DOS window.
 - Type:

```
copy c:\windows\system\testps.txt lpt1
```

- Press the Enter key, type `exit` and press the Enter key again to close the DOS window.

The printer will produce a page which shows the maximum available virtual memory and the maximum suggested virtual memory. Use the suggested value (Max Suggested VM).

2. Enter the new suggested value into the Device Options page in the box labeled Available printer memory (in KB).

The Details page

You can change the printer driver and port settings in the Details page.

The Paper page

You can change paper sizes, layout, orientation, and paper source in the Paper page. Any changes you make will override the settings in the printer's control panel for this computer only.

Paper size

You can set a default paper size by picking a new setting in the paper size box. You can scroll to the right of this box to see more paper sizes. Click on the icon of the paper size you want to be the new default.

Only the first few characters of the name of the paper size are shown beneath each icon. If you click on an icon you'll see the full name above the box. However, the paper size you click on will now be the default, unless you click on another paper size icon or click on the Cancel button at the bottom of the dialog box.

Paper source

You can set a default paper source by choosing from the Paper source drop-down list box. These options specify how paper will be provided to the printer. There are selections for:

- Auto Select.
- Any installed paper trays.
- Manual feed.
- The multipurpose feeder.

We recommend that you leave other features at their default settings.

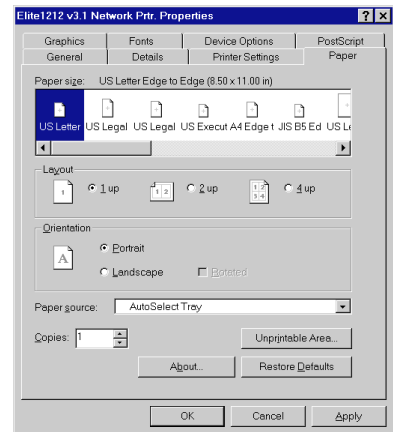

Remember that any changes you make anywhere in this page of the dialog box become the default selections for all applications on this computer.

The Graphics page

You can change aspects of the way your documents look in the Graphics page. Any changes you make will override the settings in the printer's control panel for this computer only.

Resolution

You can change the output resolution of your documents in the resolution drop-down list box. If some computers on a network are not used for documents that need a high resolution, you can set the resolution to the lowest setting (typically 300 dots per inch). Documents printed at low resolution print faster than those printed at high resolution.

The figure you set here becomes the default setting for the dialog boxes in applications on this computer. All resolutions that the printer supports are still options within application dialog boxes, so you can select higher resolutions if necessary.

Halftoning

This section controls the look of any photographs in your document. We recommend that you choose Use printer's settings.

The only time you might need to change these settings is if you print a file to disk before taking it to a service bureau. Your service bureau can advise you on the settings you should use.

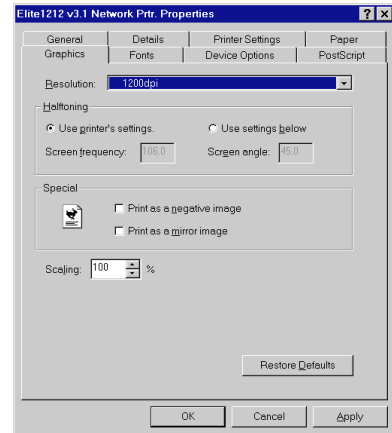

The Fonts page

The Fonts page enables you to specify how fonts are sent to the printer.

We recommend you use the default settings.

The PostScript page

The PostScript page provides settings for controlling the way print jobs are sent to the printer.

We recommend you use the default settings.

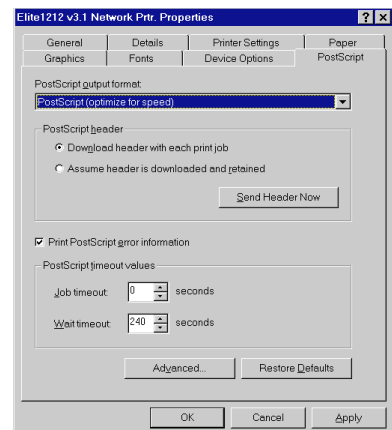

Installing printer description files

Some graphics applications need more information about the printer than the standard printer software provides. This extra information comes in files known as *printer description files*. You must copy one or more of these files from the Elite 12ppm CD-ROM into a specified folder in your application folder.

Printer description files have the following extensions: .PDF, .PDX, or .PPD. Please refer to the documentation included with the application for more information on where to copy these files and how to use them.

If you want to install printer description files, you can use Windows Explorer or open a DOS window.

Installing printer description files using Windows Explorer

1. Insert the Elite 12ppm CD-ROM into your CD-ROM drive.
2. Open Windows Explorer and choose Details from the View menu.
3. In the left pane, find the CD-ROM icon and click on it. You'll see the files contained in the root directory of the CD-ROM.
4. Click on the Type button at the top of the column in the right pane. The files are sorted into order by type (three-letter extension).
5. Follow the instructions below for each application you wish to install printer description files for.
 - Adobe Illustrator 4.0 or 4.1:
 - a. Select all files that end in .ppd.
 - b. Choose Copy from the Edit menu.
 - c. Locate the Ai4 folder in the left pane (you may have to click on the plus sign next to a drive letter).
 - d. Click on this folder to show its contents in the right pane, then double-click on the PPD folder.
 - e. Choose Paste from the Edit menu. You'll see the ppd files in the window (you may have to scroll to see them). The files are installed.
 - Adobe PageMaker 6.0 (or 6.5):
 - a. Select all files that end in .ppd.
 - b. Choose Copy from the Edit menu.

- c. Locate the Pm6 (or Pm65) folder in the left pane (you may have to click on the plus sign next to a drive letter).
 - d. Click on this folder to show its contents in the right pane, then double-click on the Rsrc folder.
 - e. Double-click on the Usenglsh folder, then double-click on the Ppd4 folder.
 - f. Choose Paste from the Edit menu. You'll see the ppd files in the window (you may have to scroll to see them). The files are installed.
- Aldus FreeHand 4.0 or PageMaker 5.0:
 - a. Select all files that end in .ppd.
 - b. Choose Copy from the Edit menu.
 - c. Locate the Aldus folder in the left pane (you may have to click on the plus sign next to a drive letter).
 - d. Click on this folder to show its contents in the right pane, then double-click on the Usenglsh folder.
 - e. Double-click on the ppd4 folder.
 - f. Choose Paste from the Edit menu. You'll see the ppd files in the window (you may have to scroll to see them). The files are installed.
 - Aldus FreeHand 3.1 and earlier:
 - a. Open the Ppd3 folder on the Elite 12ppm CD-ROM.
 - b. Select all files in this folder.
 - b. Choose Copy from the Edit menu.
 - c. Locate the Aldus folder in the left pane (you may have to click on the plus sign next to a drive letter).
 - d. Click on this folder to show its contents in the right pane, then double-click on the Usenglsh folder.
 - e. Double-click on the Ppds folder.
 - f. Choose Paste from the Edit menu. You'll see the ppd files in the window (you may have to scroll to see them). The files are installed.
 - Macromedia FreeHand 5.0:
 - a. Select all files that end in .ppd.
 - b. Choose Copy from the Edit menu.

- c. Locate the Fh5 folder in the left pane (you may have to click on the plus sign next to a drive letter).
- d. Click on this folder to show its contents in the right pane, then double-click on the Usenglsh folder.
- e. Double-click on the Ppd folder.
- e. Choose Paste from the Edit menu. You'll see the ppd files in the window (you may have to scroll to see them). The files are installed.
- QuarkXPress:
 - a. Select all files that end in .pdf.
 - b. Choose Copy from the Edit menu.
 - c. Locate the Xpress folder in the left pane (you may have to click on the plus sign next to a drive letter).
 - d. Click on this folder to show its contents in the right pane.
 - e. Choose Paste from the Edit menu. You'll see the pdf files in the window (you may have to scroll to see them). The files are installed.

Installing printer description files using an MS-DOS window

1. Insert the Elite 12ppm CD-ROM into your CD-ROM drive.
 2. Click on the Start button, and choose Programs from the Start menu.
 3. You'll see the programs installed on this machine; click on MS-DOS prompt and a DOS Window opens.
 4. Type the following command and path name for the application you are using and press the Enter key. These examples assume that your CD-ROM is drive D: and your application is on drive C: If your CD-ROM uses another drive letter, or your application is not on drive C:, change the drive letters accordingly (for example, if your CD-ROM is drive E: and Adobe Illustrator is on drive D:, the first example should read `copy e:*.ppd d:\ai4\ppd`).
- Adobe Illustrator 4.0 or 4.1:
Type `copy d:*.ppd c:\ai4\ppd` to install the PPD file.
 - Adobe PageMaker 6.0:
Type `copy d:*.ppd c:\pm6\rsrc\usenglsh\ppd4\` to install the PPD file.

- Aldus FreeHand 4.0 or PageMaker 5.0:

Type `copy d:*.ppd c:\aldus\usenglish\ppd4` to install the PPD file.

- Aldus FreeHand 3.1 and earlier:

Type `copy d:\ppd3*.* c:\aldus\usenglish\ppds` to install the PPD and PDX files.

- Macromedia FreeHand 5.0:

Type `copy d:*.ppd c:\fh5\usenglish\ppd` to install the PPD file.

- QuarkXPress:

Type `copy d:*.pdf c:\xpress` to install the PDF file.

5. Type Exit and press the Enter key to close the DOS window.

Printing from Windows 95 applications

GCC printers are designed to work with all Windows 95 compatible applications. The Print dialog box varies among applications, but all variations provide the common print commands along with others that are available for that application only.

The printer's control panel menus and the settings in the Properties dialog box provide the default settings for an application's Print dialog box.

Selecting print options

This is the Print dialog box for WordPad, a simple word processing application included with Windows 95. You'll find the Print command in the File menu of most applications. You can change the target printer, page range, and number of copies in the main Print dialog box. You can also click on the Properties button to make further changes. Other applications may provide more settings.

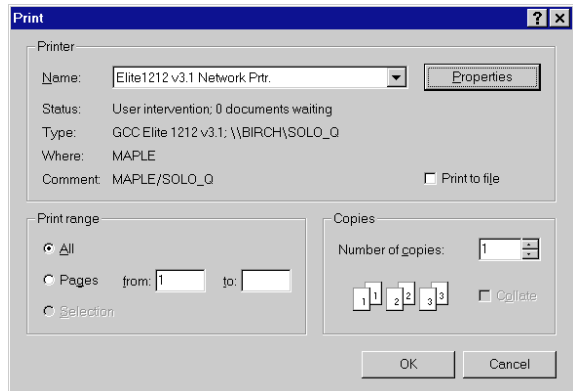

The Print Properties dialog box

If you click on Properties in WordPad's Print dialog box, you'll see this dialog box. This Properties dialog box is similar to the Printer Properties dialog box, but there are fewer pages.

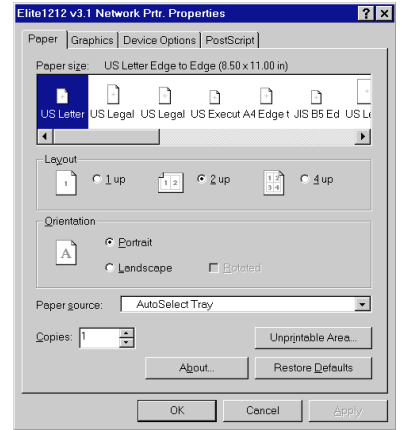

6: Using Windows NT 3.51

Windows NT printing software overview

You set up your Windows NT 3.51 computer to use the Elite 12ppm by installing the Elite 12ppm software for Windows NT 3.51. This software is on the Elite 12ppm CD-ROM.

Part of the software that you need is contained on the Windows NT 3.51 CD-ROM or floppy disks. **You must have the Windows NT 3.51 CD-ROM or floppy disks to install the software for the Elite 12ppm.**

To install the printing software, make sure that the printer is switched on and connected to the computer or network, and that the computer is switched on and running Windows NT 3.51. Then:

1. Double-click the Main group from the Program Manager window.



Main

You'll see the Main group window.

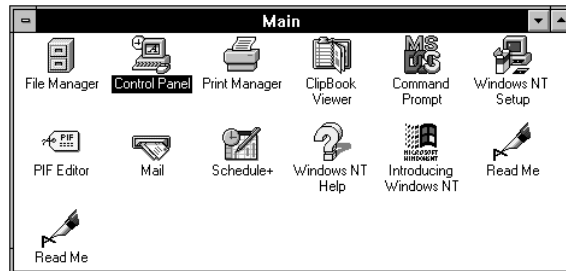

2. Double-click the Control Panel icon.

You'll see the Control Panel window.

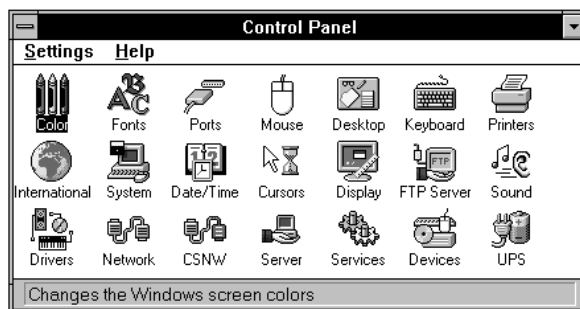

3. Double-click the Printers icon.



You'll see the Print Manager window.

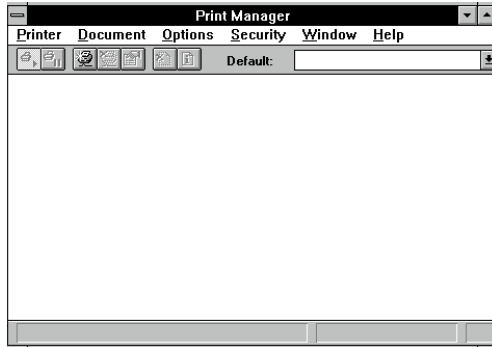

4. Select Create Printer from the Printer menu.

You'll see the Create Printer window.

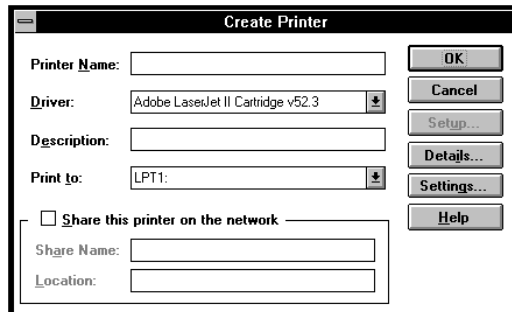

5. Insert the Elite 12ppm CD-ROM.

6. Select Other (from the bottom of the list) in the Driver drop-down list box.

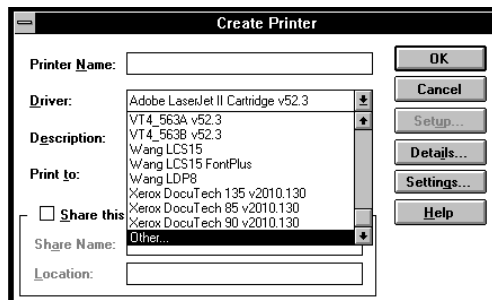

You'll see the Install driver dialog box.



Change A:\ to the drive letter of your CD-ROM drive.

7. Click OK.

You'll see the Select Driver window, with one or more Elite 12ppm models.

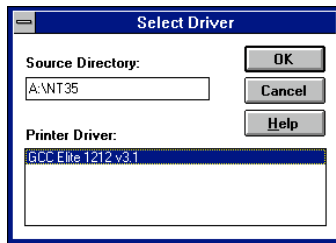

8. If necessary, select a driver.

Select the driver for the model you are installing.

9. Click OK.

You'll see a progress box. After a few seconds, the printer software is installed, and you'll see the Create Printer window again. This time it shows the driver for your Elite 12ppm printer.

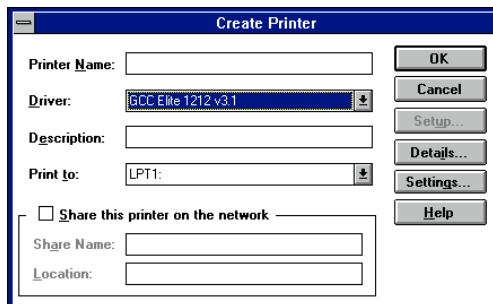

At this point you must give the printer a name, and, optionally, enter a description. If the printer is on a network, the description could be its location.

10. Go on to Section 2.

Section 2 - Select and configure a communications port.

You must now select and configure a port. A port can be either a parallel port (also called an LPT port), a serial port (also called a COM port), or you can select a network queue.

Printing using a serial port is very slow compared to using a parallel port or a network.

1. Select a port from the Print to drop-down list box.

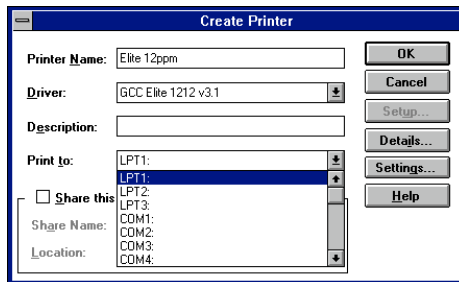

2. Click Settings.

Depending upon the type of port you chose, some type of dialog box will appear.

- If you selected an LPT port: No settings are necessary.
- If you selected a Network print queue: Your network administrator or the network software documentation has details of the settings you need to make in this dialog box. A network print queue resides on a print server. Print queues are established with the network software running your network. Any necessary settings will be specific to the network software.
- If you selected a COM port:

You'll see the Ports dialog box; the COM port you selected is highlighted.

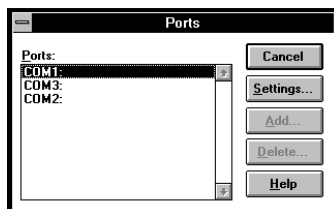

- Click Settings

You'll see the Settings dialog box.

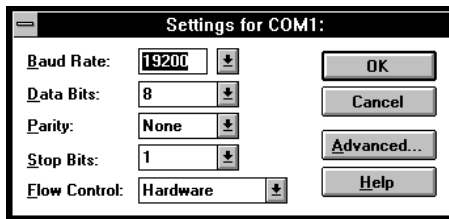

We recommend the above settings.

Note: The serial port settings in the printer's control panel menus must match the settings in this dialog box. Check the settings and change them if necessary (see the section of the CD-ROM that deals with control panel menus). Note that the DTR setting in the Flow Control submenu corresponds to the Hardware setting shown above.

- Click OK.
- Close the Ports dialog box.

You'll return to the Create Printers dialog box.

3. Click OK.

In a few seconds you'll see the PostScript Printer Setup Window.

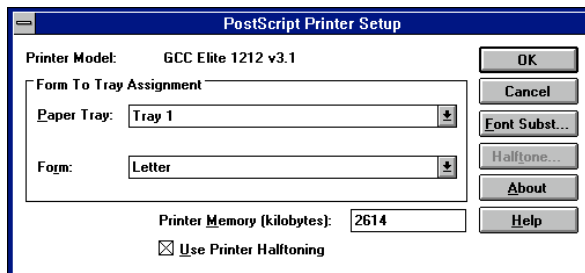

- In the Form to Tray section, choose a paper tray and paper size. Your selections should be the usual paper tray and paper size that will be used for print jobs. These settings become the default settings in the Print dialog box of all applications that run on this computer. You can override them from the Print dialog box.
- Select Use Printer Halftoning. Halftoning controls the screen frequency and screen angle for your documents. We recommend that you select Use Printer Halftoning to use the printer's default screen frequency. Note that you can change the screen frequency by using the Default Screens submenu in the printer's control panel (see the section of the CD-ROM that deals with control panel menus).

4. Click OK.

You'll see the Print Manager window, now showing an icon for the newly created printer.

You are now ready to print. Most users will not need to make any further changes. You may have special print requirements, or you may need to install PPD files for those applications that need them. You can change any of the settings by clicking once on the printers icon, then choosing Properties from the Print Manager's File menu.

This section of the CD-ROM deals only with those parts of the Properties that are specific to GCC printers. For more general information, see the Windows NT documentation.

Selecting Page Setup and Print options

GCC printers are designed to work with all applications compatible with Windows NT version 3.51 or later. The printing software provides commonly used printing options along with some others (e.g. paper sizes and paper trays) that are specific to your GCC printer model.

Printing options may be selected from within an application through the Print Setup and Print dialog boxes, or from within the Windows NT Print Manager or the Printers control panel. In general, options selected from within an application document will override corresponding options in the printers control panel, Print Manager, and the printer's control panel submenus.

Most of the options found in the Print Setup and Print dialog boxes are standard to Windows NT, while some are specific to your GCC printer model. This section details the GCC-specific options. For information on other options, please refer to the Windows NT on-line help system, and the Windows NT documentation.

The location of printing options can vary among applications, and certain options may be accessible from more than one dialog box. Refer to the application's documentation for further information.

Print Setup options

The Print Setup option is usually located under the File menu. The following Print Setup dialog box example is taken from Microsoft Write.

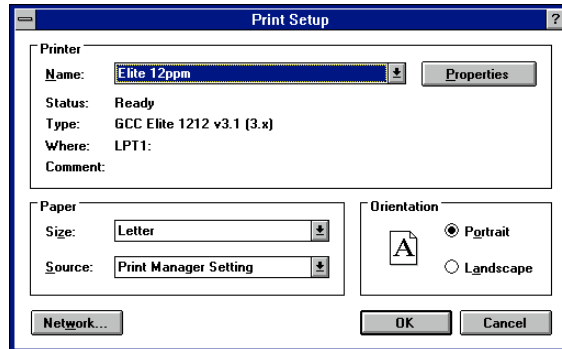

- Name - The Name drop-down list box enables you to select the printer that you wish to send a job to. The printer that initially appears in the box is the default printer. The default printer is set through the Print Manager.
- Size - The Size drop-down list box enables you to select a paper size. Available paper sizes will differ between GCC printer models.
- Orientation - This option determines the orientation of the image on the page. Vertical, or Portrait, orients the image upright on the page. Horizontal, or Landscape, orients the image sideways on the page. The default is Portrait.

Print options

The Print command is usually located under the File menu. The following Print dialog box example is taken from Microsoft Write.

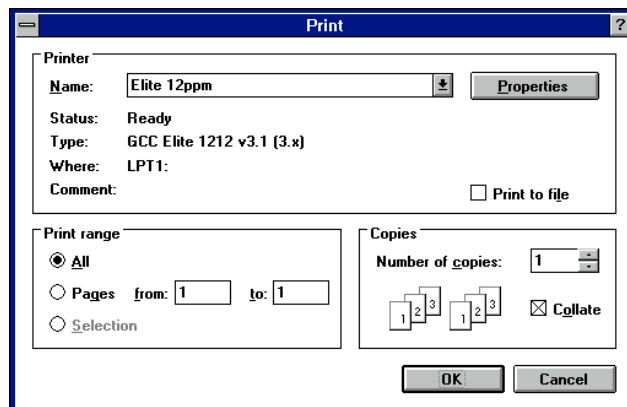

- Print Range -The Print Range option default is All, which prints all of the pages in the document, from first to last. From and To allow you to specify a range of pages to print. Click in the box labeled From, and type the first page number of the range you want to print. Then click in the box labeled To and type the last number of the range.

7: Using Windows NT 4.0

Windows NT 4.0 printing software overview

You set up your Windows NT 4.0 computer to use the Elite 12ppm by installing the Elite 12ppm software for Windows NT 4.0. This software is on the Elite 12ppm CD-ROM.

Windows NT 4.0 uses a Wizard to help you install printer software. A Wizard is a series of dialog boxes. In each dialog box you make configuration choices then click the Next button to move to the next dialog box.

This installation guide does not cover connecting to a networked printer or making your printer available for sharing by others. Details of these operations are contained on your Windows NT 4.0 CD-ROM.

Important: Part of the software that you need is contained on the Windows NT 4.0 CD-ROM. You *must* have the Windows NT 4.0 CD-ROM to install the software for the Elite 12ppm.

To install the printing software, make sure that the printer is switched on and connected to the computer or network. Also place the Elite 12ppm CD-ROM in your CD-ROM drive. Then:

1. Click on the Start button.
2. You'll see the Start menu. Click on Settings, then click on Printers on the submenu.
3. You'll see the Printers folder. Double-click the Add Printer icon.

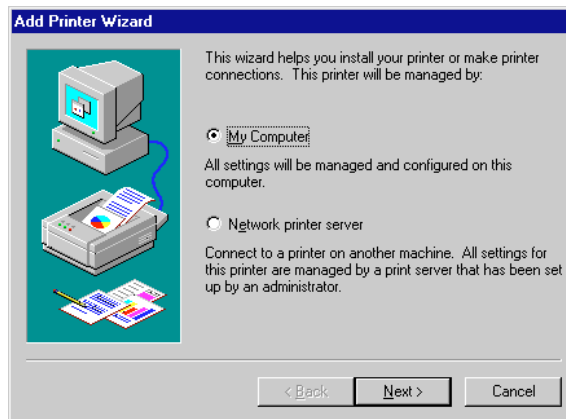

4. You'll see the local/network dialog box.
 - Choose My Computer and click the Next button.

5. You'll see a list of ports.

- Select the port(s) you'll be using and click Next.

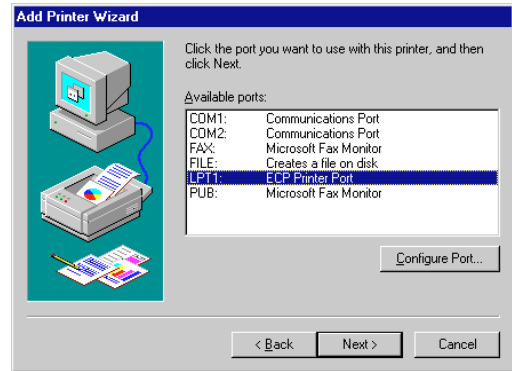

6. You'll see a dialog box that lists makes and models of printers. Ignore the settings in these boxes and click the Have Disk button.

7. You'll see the Install from disk dialog box.

- Change the drive letter in the dialog box to the drive letter of your CD-ROM, and click OK

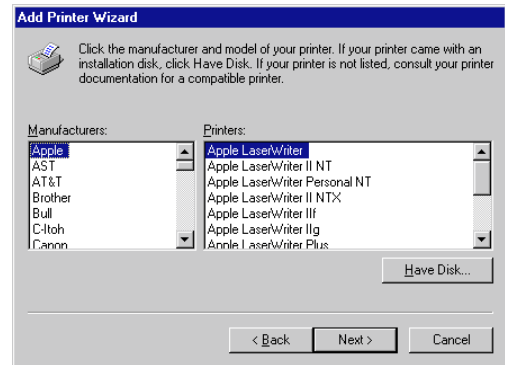

8. You'll see a dialog box with the names of one or more Elite 12ppm printers.

- Select your Elite 12ppm printer model from the disk, and click on the Next button.

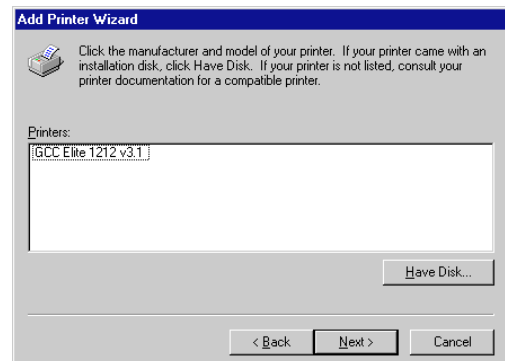

9. You'll see the printer name dialog box.

- You can type a name or accept the name in the box. Click Next.

10. You'll see a dialog box that asks whether you want to share this printer with others. Choose Not Shared, and click Next (Consult your Windows NT documentation for details on sharing your printer with other users).

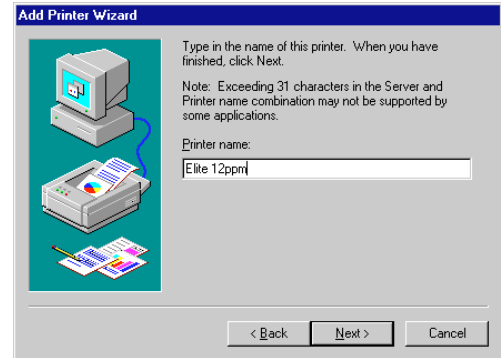

11. You'll see the Print a Test Page dialog.

- Change the setting to No. Because you may have to make changes after the software is installed, we recommend that you don't print the test page at this point. You'll print a test page when the installation is complete.

- Click Finish.

- The software installation will now commence. At one point, you'll be prompted to insert the Windows NT 4.0 CD-ROM that contains the NT 4.0 printer driver.

12. When you see a prompt, remove the Elite 12ppm CD-ROM and insert the Windows 4.0 CD-ROM. Click OK.

13. You'll see the Locate File dialog box. Click Browse. The Windows NT CD-ROM may run automatically if you have Autorun selected (the Windows NT default). This opens a large Window over the screen; click on the close box at the top right of the window.

- Select your CD-ROM drive. Choose the I386 folder.
- Choose the file called Pscript.dl_
- Click the Open button.

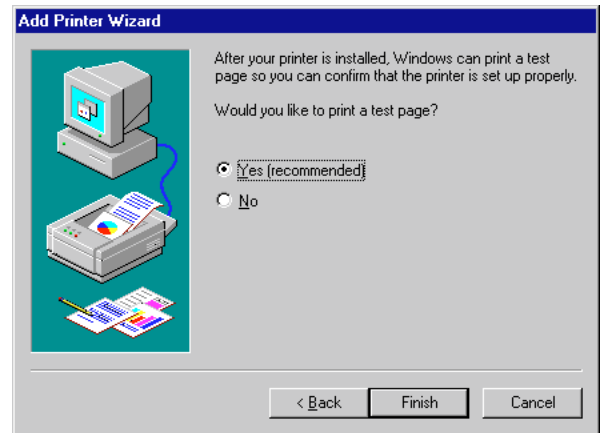

14. You'll see the Locate File dialog box again. Click OK.

- The printer software is now installed and you'll see the Printers Window with your printer icon in it.

15. Right mouse button click on this icon, and choose Properties from the list.

16. You'll see the Properties tabbed dialog box. Click on the Device Settings tab at the top of the dialog box.

- If your printer has options like extra paper trays or more memory, you'll need to make changes here. See the section "Device Options," later in this guide.

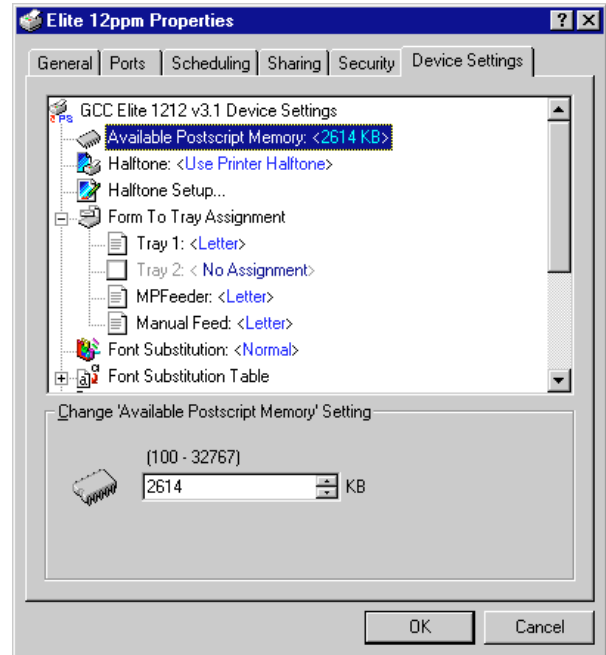

17. Click on the General tab at the top of the dialog box.

18. Click Print Test Page.

The test page will be formatted and a message box will appear asking you if the test page printed successfully. Wait a few seconds to see if the test page prints. If the test page printed, click Yes; if there is a problem, click No (Windows NT 4.0 will display troubleshooting steps).

If your page printed correctly, you've completed the normal installation process. You may need to install printer description files if your applications need them. Read the section "installing printer description files" later in this guide.

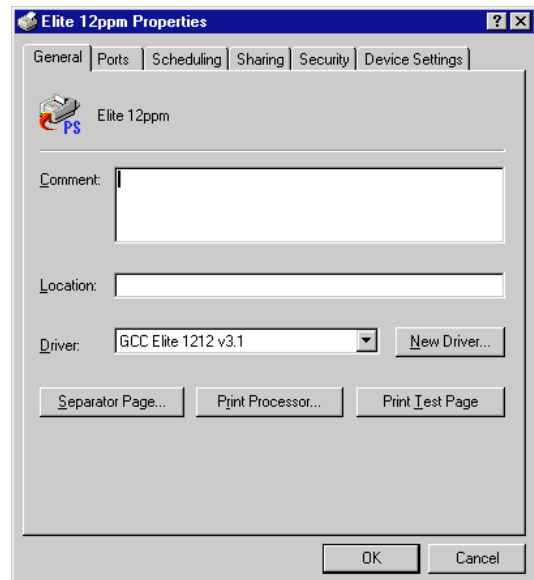

Exploring the Properties and Document Defaults dialog boxes

Now that you have installed the printing software in Windows NT 4.0, there are a number of settings that you may need to change if you have special printing requirements. Most users will not need to make any changes here.

You'll make most of the changes in the Properties dialog box, but some settings are in the Document Defaults. You can get to the Document Defaults dialog box by highlighting your printer in the Printers window and choosing Document Defaults from the File menu.

Most of the Properties dialog box contains options that are the same for all printers using Windows NT 4.0, so this section of this installation guide only covers the options provided by GCC. If you want information on options for all Windows NT 4.0 printers, please refer to the Windows NT 4.0 on-line help system and Windows NT 4.0 documentation. You can also get information about an item in a dialog box by clicking on the question mark button at the top right of most dialog boxes.

The changes you make in the Properties and Document Default dialog boxes affect all applications, but on this computer only.

The Properties dialog box

If you don't already have the Properties dialog box displayed:

1. Click on the Start button. You'll see the Start menu.
2. Choose Settings, then choose Printers from the submenu that appears.
3. You'll see the Printers window. Use the right mouse button to click on the Elite 12ppm icon, and choose Properties from the pop-up menu.

The Properties dialog box has tabs across the top. Click on the tabs to see other *pages*. Each page has options to configure your printer.

The Device Settings page

Click on the Device Settings tab to see the Device Settings page. This page contains settings specific to your GCC printer model.

In the Printer features box you'll see options specific to your printer. If you want to change the current setting of any feature, click on its name in the upper box. You'll see settings in the "Change setting" area below. Click on the setting you want to change.

Note: The features you see in the list vary between printer models. The Configuration Page has details of the specific features in your printer.

If you add options (like more paper trays or extra printer RAM), you need to change the Installable options list. After you have changed this option, Print dialog boxes in this computer's applications will show extra paper trays, for example.

Note on VMOption: The VMOption selection corresponds to the amount of RAM installed in the printer. If you add or subtract printer memory, you will need to change the amount shown under VMOption. If memory was added to your printer before you installed the Windows NT 4.0 printer software, you will need to change the VMOption amount.

If you have to change the printer memory size, click on VMOption and select the correct memory size from the drop-down list box. Answer Yes to the question about available printer memory. Also, see the following section on updating the printer driver to reflect the new amount of printer memory.

Updating the printer driver to reflect the new amount of printer memory

If you install additional memory in your printer, you must update the printer driver. You do this by adjusting the Available printer memory setting at the top of the Device Settings page. When the Available printer memory figure is correct, your computer will send files that print faster.

The Available Memory figure is less than the amount of RAM you have installed in your printer, because part of the RAM is used by the printer for utilities.

If you routinely download more than one or two fonts to the printer's memory, you should also update your Available printer memory, even if you have not added any extra memory to the printer. Download your normal font set and then update the memory.

If you want to update the printer driver, you first have to copy a file to the printer, using a DOS window (do not use Windows NT 4.0's Print command). This prints a page that tells you the maximum suggested virtual memory for the printer. You then enter the figure in this dialog box.

1. Copy the file TESTPS.TXT to the printer. This file is included with Windows NT 4.0.
 - Click on the Start button, then choose Programs from the Start menu. Click on MS-DOS Prompt in the program list; you'll see a DOS window.
 - The following example assumes that your printer is connected to your computer through the LPT1 port. Type:

```
copy c:\windows\system\testps.txt lpt1
```
 - Press the Enter key, type `exit` and press the Enter key again to close the DOS window.

The printer will produce a page which shows the maximum available virtual memory and the maximum suggested virtual memory. Use the suggested value (Max Suggested VM).

2. Enter the new suggested value into the Device Settings page in the box labeled Available printer memory (in KB).
3. Update the new RAM value by clicking on Memory Configuration and choosing a new value, equal to the amount of memory in your printer.

Other general items in Device Settings

- The form to tray assignment sets defaults for the paper size for each paper tray.
- Font substitution replaces certain common fonts on Windows systems (such as Arial) with the PostScript equivalents on the printer (Helvetica replaces Arial). We recommend that you keep the default settings.
- PS timeout values control how long the computer will attempt to print to a port before reporting that it is unable to print. The default setting of zero actually means that there is no limit. We recommend that you keep these settings.

Other GCC-specific items in Device Settings

- Additional paper trays lets you tell the computer that you have installed any additional paper trays. These trays then appear as an option in the Print dialog boxes of applications.
- Paper size lets you choose the default paper size. You can override this in an application's Page Setup dialog box.

The Document Defaults dialog box

You can set additional defaults in this dialog box. These defaults will apply to every application running on this computer only, and can be overridden in an application's Page Setup and Print dialog boxes.

Opening the Document Defaults dialog box

If the Document Defaults dialog box is not already open, follow these steps:

1. On the Start Menu, choose Settings, and then choose Printers from the sub-menu.
2. You'll see the Printers window. Click once on your printer.

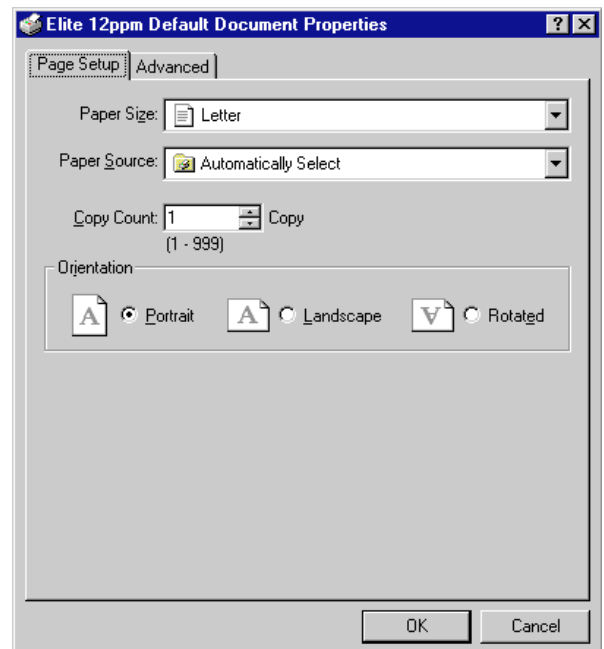

3. Go to the File menu in the Printers window, and choose Document Defaults from the menu.

GCC-specific items

There are several items (depending on the product you have installed) in the Document Defaults dialog box which are added when you install a GCC printer. You'll find them if you click on the Advanced tab and scroll to the bottom of the window.

- AccuGray is GCC's technology for improving the reproduction of photographs. We recommend that you leave this at the default setting of Enabled.
- TonerMiser (*Elite 1212 only*) lets you use less toner when printing drafts of a document for proofing.
- Smoothing (*Elite 1212 only*) reduces the jagged appearance of text and graphics.
- The Output Tray option allows you to select the default output location, either TOP (face down) or REAR (face up).

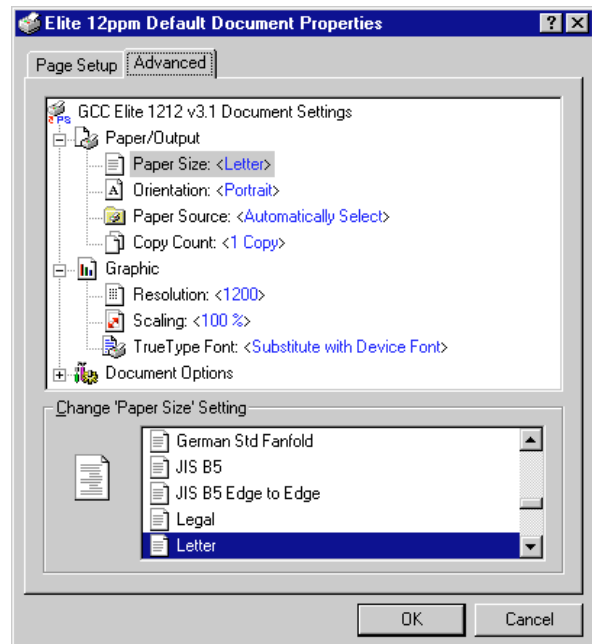

Other items in the Advanced page

Most of the items in Document Defaults control what will be the defaults in the Page Setup and Print dialog boxes in your applications. Any changes you make will override the settings in the printer's control panel for this computer only.

If you are constantly making changes in these dialog boxes, you may find that you can avoid this by making changes in the Paper/Output and Graphic section. The new settings will then become the defaults in applications. Note that the Graphic section applies to the whole document and not just to any graphic images within documents.

We recommend that unless you need to change paper sizes and paper sources, you should leave these settings at their defaults. However, you may want to change the Resolution setting (see next section).

Resolution

You can change the output resolution of your documents using the Resolution section of the Graphic part of the Advanced Document Defaults. If some computers on a network are not used for documents that need a high resolution, you can set the resolution to the lowest setting (typically 300 dots per inch). Documents printed at low resolution print faster than those printed at high resolution.

The figure you set here becomes the default setting for the dialog boxes in applications on this computer. All resolutions that the printer supports are still options within application dialog boxes, so you can select higher resolutions when necessary.

Installing printer description files

Some graphics applications need more information about the printer than the standard printer software provides. This extra information comes in files known as *printer description files*. You must copy one or more of these files from the Elite 12ppm CD-ROM into a specified folder in your application folder.

Printer description files have the following extensions: .PDF, .PDX, or .PPD. Please refer to the documentation included with the application for more information on where to copy these files and how to use them.

You can use Windows Explorer or open a DOS window to install printer description files.

Installing printer description files using Windows Explorer

1. Insert the Elite 12ppm CD-ROM into your CD-ROM drive.
2. Open Windows Explorer and choose Details from the View menu.
3. In the left pane, find the CD-ROM icon and click on it. You'll see the files contained in the root directory of the CD-ROM.
4. Click on the Type button at the top of the column in the right pane. The files are sorted into order by type (three-letter extension).
5. Follow the instructions below for each application you wish to install printer description files for.
 - Adobe Illustrator 4.0 or 4.1:
 - a. Select all files that end in .ppd.
 - b. Choose Copy from the Edit menu.
 - c. Locate the AI4 folder in the left pane (you may have to click on the plus sign next to a drive letter).

- d. Click on this folder to show its contents in the right pane, then double-click on the PPD folder.
 - e. Choose Paste from the Edit menu. You'll see the ppd files in the window (you may have to scroll to see them). The files are installed.
- Adobe PageMaker 6.0:
 - a. Select all files that end in .ppd.
 - b. Choose Copy from the Edit menu.
 - c. Locate the Pm6 folder in the left pane (you may have to click on the plus sign next to a drive letter).
 - d. Click on this folder to show its contents in the right pane, then double-click on the Rsrc folder.
 - e. Double-click on the Usenglsh folder, then double-click on the Ppd4 folder.
 - f. Choose Paste from the Edit menu. You'll see the ppd files in the window (you may have to scroll to see them). The files are installed.
 - Aldus FreeHand 4.0 or PageMaker 5.0:
 - a. Select all files that end in .ppd.
 - b. Choose Copy from the Edit menu.
 - c. Locate the Aldus folder in the left pane (you may have to click on the plus sign next to a drive letter).
 - d. Click on this folder to show its contents in the right pane, then double-click on the Usenglsh folder.
 - e. Double-click on the ppd4 folder.
 - f. Choose Paste from the Edit menu. You'll see the ppd files in the window (you may have to scroll to see them). The files are installed.
 - Aldus FreeHand 3.1 and earlier:
 - a. Open the Ppd3 folder on the Elite 12ppm CD-ROM.
 - b. Select all files in this folder.
 - b. Choose Copy from the Edit menu.
 - c. Locate the Aldus folder in the left pane (you may have to click on the plus sign next to a drive letter).

- d. Click on this folder to show its contents in the right pane, then double-click on the Usenglsh folder.
 - e. Double-click on the Ppds folder.
 - f. Choose Paste from the Edit menu. You'll see the ppd files in the window (you may have to scroll to see them). The files are installed.
- Macromedia FreeHand 5.0:
 - a. Select all files that end in .ppd.
 - b. Choose Copy from the Edit menu.
 - c. Locate the Fh5 folder in the left pane (you may have to click on the plus sign next to a drive letter).
 - d. Click on this folder to show its contents in the right pane, then double-click on the Usenglsh folder.
 - e. Double-click on the Ppd folder.
 - e. Choose Paste from the Edit menu. You'll see the ppd files in the window (you may have to scroll to see them). The files are installed.
 - QuarkXPress:
 - a. Select all files that end in .pdf.
 - b. Choose Copy from the Edit menu.
 - c. Locate the Xpress folder in the left pane (you may have to click on the plus sign next to a drive letter).
 - d. Click on this folder to show its contents in the right pane.
 - e. Choose Paste from the Edit menu. You'll see the pdf files in the window (you may have to scroll to see them). The files are installed.

Installing printer description files using an MS-DOS window

1. Insert the Elite 12ppm CD-ROM into your CD-ROM drive.
2. Click on the Start button, and choose Programs from the Start menu.
3. You'll see the programs installed on this machine; click on Command Prompt and a DOS Window opens.
4. Type the following command and path name for the application you are using and press the Enter key. These examples assume that your CD-ROM is drive D: and your application is on drive C: If your CD-ROM uses another drive letter, or

your application is not on drive C:, change the drive letters accordingly (for example, if your CD-ROM is drive E: and Adobe Illustrator is on drive D:, the first example should read `copy e:*.ppd d:\ai4\ppd`).

- Adobe Illustrator 4.0 or 4.1:

Type `copy d:*.ppd c:\ai4\ppd` to install the PPD file.

- Adobe PageMaker 6.0:

Type `copy d:*.ppd c:\pm6\rsrc\usenglish\ppd4\` to install the PPD file.

- Aldus FreeHand 4.0 or PageMaker 5.0:

Type `copy d:*.ppd c:\aldus\usenglish\ppd4` to install the PPD file.

- Aldus FreeHand 3.1 and earlier:

Type `copy d:\ppd3*.* c:\aldus\usenglish\ppds` to install the PPD and PDX files.

- Macromedia FreeHand 5.0:

Type `copy d:*.ppd c:\fh5\usenglish\ppd` to install the PPD file.

- QuarkXPress:

Type `copy d:*.pdf c:\xpress` to install the PDF file.

5. Type Exit and press the Enter key to close the DOS window.

Printing from Windows NT 4.0 applications

GCC printers are designed to work with all Windows NT 4.0 compatible applications. The Print dialog box varies among applications, but all variations provide the common print commands along with others that are available for that application only.

The printer's control panel menus and the settings in the Properties dialog box provide the default settings for an application's Print dialog box.

Selecting print options

This is the Print dialog box for WordPad, a simple word processing application included with Windows NT 4.0. You'll find the Print command in the File menu of most applications. You can change the target printer, page range, and number of copies in the main Print dialog box. You can also click on the Properties button to make further changes. Other applications may provide more settings.

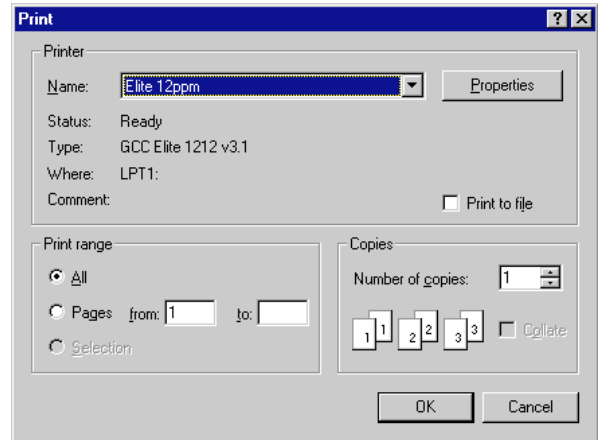

The Print Properties dialog box

If you click on Properties in WordPad's Print dialog box, you'll see this dialog box. This Properties dialog box is similar to the Printer Properties dialog box, but there are fewer pages.

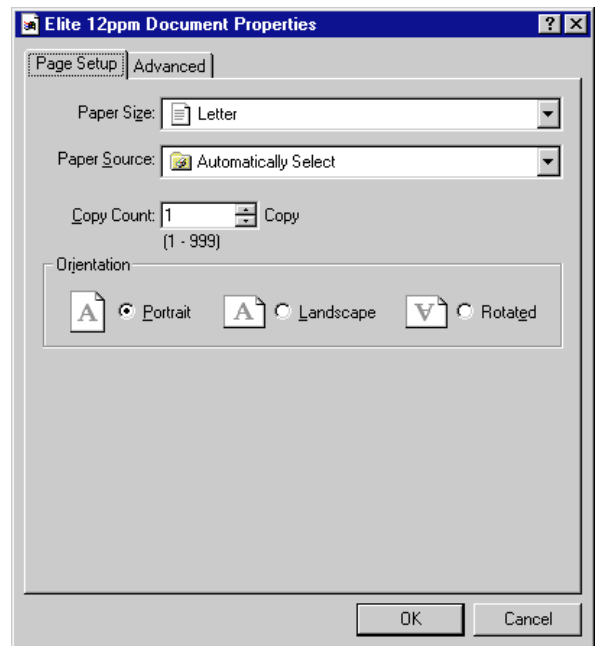

8: Using DOS

There are two ways to print from DOS — within a DOS application or from the DOS command line. In some cases you may want to save a file in a form that can be copied from DOS directly to the printer. This process is called *Printing to file* or *Printing to disk*.

Overview of setup and printing from a DOS application

You cannot configure DOS once for every application, like Windows. You have to configure every DOS application individually with a printer driver and port setting information. However, you must configure the port once in every DOS session. You can do this either in the command line (at the prompt) or include a line in your AUTOEXEC.BAT file to do this automatically. See the Port Configuration section.

When you print, the printer driver formats your file so that the Elite 12ppm knows whether to use PostScript or PCL.

When you want to configure DOS printing from an application:

1. Select an emulation mode on the printer's control panel. When you print, your print job will be formatted for either PostScript or PCL; set the PS/PCL Sensing submenu to either PostScript Only, PCL Only, or Auto Switch.
2. Select a printer driver from within the DOS application. DOS applications typically give you a choice of printer drivers. Select the LaserWriter II NTX for PostScript printing or the LaserJet III for PCL printing. If the LaserWriter II NTX driver isn't offered by your DOS application, choose LaserWriter II, or LaserWriter. If the LaserJet III driver isn't offered by your DOS application, choose LaserJet II, or LaserJet.
3. Check the application's port settings. The applications's port settings and the Elite 12ppm control panel port settings must match.

This DOS application is now ready to print. You can either print the file directly to the Elite 12ppm or print it to a disk file; later, you can print this file directly from DOS.

Overview of setup and printing from DOS command line

If you want to print a file that has been printed to disk, you need to use the DOS command line:

1. Check the port settings. The port settings on the Elite 12ppm control panel and your computer must match.
2. Select an emulation mode on the printer's control panel. When you print, your print file will be formatted for either PostScript or PCL; set PS/PCL sensing

submenu through the Elite 12ppm control panel to either PostScript Only, PCL Only, or Auto Switch.

3. Use the DOS Copy command to send the print file to the Elite 12ppm. See "Using the Copy command" later in this section.

Port configuration – DOS

If you want to print from DOS, you must configure a port once in every DOS session. Most users add a line to their AUTOEXEC.BAT file so that this is done automatically. The port you configure must be the same as the port that is specified in the DOS application and in the control panel of your printer.

If you have used another printer to print from DOS, you may find that your AUTOEXEC.BAT file already includes one of the commands shown in the next sections.

Your PC and the Elite 12ppm are connected through either a parallel or RS-422 serial interface.

Parallel Port

To set up the parallel port for communication between the Elite 12ppm and the PC, type the following MS-DOS command before printing:

```
MODE LPT1 : , , P
```

This command allows the Centronics busy signal to be active for extended periods of time so that the computer does not abort long print jobs. If you are printing through a parallel port other than LPT1, substitute that port's number in the above MODE command.

Serial Port

To set up the RS-422 serial port for communication between the Elite 12ppm and the PC, type the following MS-DOS command before printing:

```
MODE COM1 : 9600 , N , 8 , 1
```

The above MODE command configures the PC serial port for a baud rate of 9600, no parity, 8 data-bits, 1 stop-bit, and for XON/XOFF flow control. These settings match the Elite 12ppm's RS-422 front panel factory default settings. XON/XOFF flow control is widely used, but check your application's documentation to see if that handles this protocol. It is important that the application support XON/XOFF because standard DOS commands such as PRINT and COPY cannot.

However, we recommend that instead of XON/XOFF flow control, you use DTR flow control. DTR flow control is preferred because DOS has better support for it, as it matches the flow control preferred by Windows and thus provides more reliable communication

when sending PCL jobs to the printer. To use DTR flow control, type the following MS-DOS command before printing:

```
MODE COM1:9600,N,8,1,P
```

Note: You will need to change the Elite 12ppm's flow control submenu setting to DTR if you use the this MODE command.

Note: In both the parallel and serial Mode command examples shown in this section, the P switch may be replaced by the B switch. The B switch is available with MS-DOS version 4.0 and later. (Not all applications support the B switch.)

Redirecting DOS to a serial port

DOS and some DOS applications only print through a parallel port. If you set up the Elite 12ppm to print through the RS-422 serial port, you will need to add an additional MODE command to redirect your output to the serial port. The following command should be typed after the previous serial port MODE commands:

```
MODE LPT1: = COM1:
```

This command redirects to serial port COM1 the output that DOS or your DOS application would normally send to the parallel port. If you use a different serial port (i.e., COM 2, 3, or 4) substitute that number.

Note: A more efficient way of using the MODE commands is to add them to your AUTOEXEC.BAT file. Refer to your PC documentation for information about editing the AUTOEXEC.BAT file.

Selecting a printer driver

PostScript

If an application supports PostScript, we recommend that you configure the application to use a PostScript printer driver. Printing using a PostScript printer driver enables the application to use the 11 high quality PostScript font families included with the Elite 12ppm at all available resolutions. We recommend that you use the LaserWriter II NTX printer driver if it is available with your application. If not, use LaserWriter II or LaserWriter. Refer to the application's documentation for more information.

PCL 5

The Elite 12ppm also includes PCL 5/HP-GL/2 emulation software, which provides LaserJet III text and graphics compatibility plus the ability to print at 600 dpi. If you are using a PCL application, we recommend that you configure the application to print to a LaserJet III. If LaserJet III is not available, use a LaserJet II. If a LaserJet II is not available, use LaserJet. Refer to the application's documentation for more information.

Note: If your document uses 300 dpi user-defined patterns or 300 dpi bitmap fonts, the Elite 12ppm will only be able to print these at 300 dpi even if 600 dpi PCL is selected. Also, the Elite 12ppm includes 15 PCL fonts that are compatible with those in the HP LaserJet III. These fonts consist of 7 bitmap and 8 scalable fonts. If you have configured your Elite 12ppm to print PCL at 600 dpi, the internal bitmap fonts will only print at 300 dpi. The internal scalable fonts will print at 600 dpi, as will any downloaded scalable font.

Note: In PCL 5 emulation, the Elite 12ppm can print at either 300 or 600 dpi resolution. The default resolution is 300 dpi. Resolution is set via the Resolution submenu. Also, although most PCL applications send the necessary commands specifying font, character pitch, point size, etc., the Elite 12ppm front panel can be used to set many PCL print characteristics.

The PCL 5 printer language was developed by Hewlett-Packard. For more information about commands supported by PCL 5, see the *HP PCL 5 Printer Language Technical Reference Manual* (Manual Part No. 5961-0509).

Using the Copy command

If you printed to a file from a DOS application, you must use the DOS COPY command to make the printer print the file. The following command is a typical example:

```
COPY /B myfile.prn LPT1
```

This sends the file myfile.prn to the parallel port LPT1 and to the device connected to that port. The binary mode switch /B is needed so that all control characters are sent to the printer as data.

Note: GCC recommends that you don't use the DOS PRINT command. Although this command can produce faster print times, you can't use binary mode. This can cause printing problems with complex files. However, if you are sending simple text files, the PRINT command may work.

9: Fonts

Introduction

The Elite 12ppm supports a wide range of font types and formats for both the PostScript and PCL environment.

For PostScript users, the Elite 12ppm comes with 11 high-quality PostScript font families built into its internal hardware. These fonts are in the Bitstream® Speedo™ format and are designed to match the corresponding Adobe Type 1 fonts.

The Elite 12ppm can also render any Adobe Type 1 and Apple TrueType™ fonts that you may be using in your documents. When a document contains fonts that are not built into the printer, the high-quality outline versions of the fonts will be automatically downloaded to the printer during the print job and then removed after the job has finished. You may also *manually* download fonts to the printer's internal memory (RAM) by using the LaserWriter Utility, included with the Elite 12ppm software, or downloaders included with many font packages; manually downloading fonts can make printing faster. When fonts are manually downloaded to the printer, they remain in the printer's RAM and available for all print jobs sent to the printer for as long as the printer is switched on; the fonts are removed from RAM when the printer is switched off.

For PCL 5 users, the Elite 12ppm comes with two high quality PCL outline font families and two 300 dpi bitmap fonts. The outline fonts are in the Bitstream Speedo format, which are designed to match the AGFA Intellifont® fonts found in the HP LaserJet III.

Resident PostScript fonts

The Elite 12ppm comes with 11 high quality PostScript font families installed in the printer's ROM: Times, Helvetica, Courier, Symbol, Helvetica Narrow, Palatino, Avant Garde, Bookman, New Century Schoolbook, Zapf Chancery, and Zapf Dingbats. The Elite 12ppm printing software includes the matching bitmap screen fonts for the Macintosh. Screen fonts are the bitmapped images that appear on the screen and are selected from within a document. When you click the **Print** button, the Macintosh sends a description of the bitmap screen font to the Elite 12ppm in the PostScript page description language. The Elite 12ppm uses the PostScript interpreter to print the high quality outline font. For more information on the structure of the PostScript language, Adobe offers three books, published by Addison-Wesley: *PostScript Language Reference Manual (2nd Edition)*, *PostScript Language Cookbook and Tutorial*, and *PostScript Language Program Design*.

PostScript resident font catalog

Times	Bitstream Dutch™ A B C D E F G H I J K L M N O P Q R S T U V W X Y Z a b c d e f g h i j k l m n o p q r s t u v w x y z 1 2 3 4 5 6 7 8 9 0 Typefaces: plain, bold , <i>italic</i> , bold italic
Helvetica	Bitstream Swiss™ A B C D E F G H I J K L M N O P Q R S T U V W X Y Z a b c d e f g h i j k l m n o p q r s t u v w x y z 1 2 3 4 5 6 7 8 9 0 Typefaces: plain, bold , <i>italic</i> , bold italic
Courier	Courier A B C D E F G H I J K L M N O P Q R S T U V W X Y Z a b c d e f g h i j k l m n o p q r s t u v w x y z 1 2 3 4 5 6 7 8 9 0 Typefaces: plain, bold , <i>italic</i> , bold italic
Symbol	Symbol A B X Δ E Φ Γ H I ϑ K Λ M N O Π Θ P Σ T Y ζ Ω Ξ Ψ Z α β χ δ ε φ γ η ι ϕ κ λ μ ν ο π θ ρ σ τ υ ω ξ ψ ζ 1 2 3 4 5 6 7 8 9 0 Typeface: plain
Helvetica Narrow	Bitstream Swiss Narrow™ A B C D E F G H I J K L M N O P Q R S T U V W X Y Z a b c d e f g h i j k l m n o p q r s t u v w x y z 1 2 3 4 5 6 7 8 9 0 Typefaces: plain, bold , <i>italic</i> , bold italic
Palatino	Bitstream Zapf Calligraphic™ A B C D E F G H I J K L M N O P Q R S T U V W X Y Z a b c d e f g h i j k l m n o p q r s t u v w x y z 1 2 3 4 5 6 7 8 9 0 Typefaces: plain, bold , <i>italic</i> , bold italic

Avant Garde

ITC Avant Garde® Gothic
 A B C D E F G H I J K L M N O P Q R S T U V W X Y Z
 a b c d e f g h i j k l m n o p q r s t u v w x y z 1 2 3 4 5 6 7 8
 9 0

Typefaces: book, **bold**, *italic*, **bold italic**

Bookman

Bookman®
 A B C D E F G H I J K L M N O P Q R S T U V W X Y Z
 a b c d e f g h i j k l m n o p q r s t u v w x y z 1 2 3 4 5 6 7 8
 9 0

Typefaces: light, **bold**, *light italic*, **bold italic**

New Century Schoolbook

New Century Schoolbook®
 A B C D E F G H I J K L M N O P Q R S T U V W X Y Z
 a b c d e f g h i j k l m n o p q r s t u v w x y z 1 2 3 4 5 6 7 8
 9 0

Typefaces: roman, **bold**, *italic*, **bold italic**

Zapf Chancery

ITC Zapf Chancery®
 A B C D E F G H I J K L M N O P Q R S T U V W X Y Z
 a b c d e f g h i j k l m n o p q r s t u v w x y z 1 2 3 4 5 6 7 8 9 0

Typeface: *medium italic*

Zapf Dingbats

ITC Zapf Dingbats®



Typeface: plain

PCL resident font catalog

The Elite 12ppm includes 2 PCL outline font families (Times and Univers) and 2 bitmap fonts (Courier and Line Printer).

Times

Bitstream Dutch

A B C D E F G H I J K L M N O P Q R S T U V W X Y Z
a b c d e f g h i j k l m n o p q r s t u v w x y z 1 2 3 4 5 6 7 8 9 0

Typefaces: plain, **bold**, *italic*, ***bold italic***

Univers

Bitstream Zurich

A B C D E F G H I J K L M N O P Q R S T U V W X Y Z
a b c d e f g h i j k l m n o p q r s t u v w x y z 1 2 3 4 5 6 7 8 9 0

Typefaces: plain, **bold**, *italic*, ***bold italic***

Courier

Courier

A B C D E F G H I J K L M N O P Q R S T U V W X Y Z
a b c d e f g h i j k l m n o p q r s t u v w x y z
1 2 3 4 5 6 7 8 9 0

Typefaces: 10 pt., **10 pt. bold**, *10 pt. italic*,
12 pt., **12 pt. bold**, *12 pt. italic*

Line Printer 16

Line Printer 16

A B C D E F G H I J K L M N O P Q R S T U V W X Y Z
a b c d e f g h i j k l m n o p q r s t u v w x y z 1 2 3 4 5 6 7 8 9 0

■ Symbol sets

The symbol sets supported by the Elite 12ppm for resident bitmapped fonts are:

ISO 2: Int'l Reference Version

ISO 21: German

ISO 4: United Kingdom

ISO 25: French

ISO 6: ASCII

ISO 60: Norwegian version 1

ISO 10: Swedish

ISO 61: Norwegian version 2

ISO 11: Swedish Names

ISO 69: French

ISO 14: JIS ASCII

ISO 84: Portuguese

ISO 15: Italian

ISO 85: Spanish

ISO 16: Portuguese

HP German, HP Spanish, HP Legal,

ISO 17: Spanish

ECMA-94 Latin 1, PC-8, PC-8 (DN), and PC 850

In addition to the symbol sets listed, the Elite 12ppm supports the following symbol sets for resident scalable fonts:

Ventura Math

Ventura International

Ventura US

PostScript Text

PostScript Math

MS Publishing

Windows

Desktop

Math-8

PI Font

Font compatibility

■ Type 1 fonts

The Elite 12ppm is compatible with Type 1 fonts. When using Adobe Type Manager® (ATM®), these PostScript language outline fonts appear crisp and smooth on the computer screen, as well as the printed output. ATM is also used to create bitmapped font data at any size from the Type 1 fonts. For more information on adding and removing Type 1 fonts, refer to Adobe's documentation.

■ TrueType fonts

The Elite 12ppm is compatible with TrueType fonts. TrueType is an advanced font technology that produces high-quality output on the screen as well as on printed output.

Macintosh

If you are using a TrueType font that is equivalent to an Elite 12ppm resident font, the Elite 12ppm automatically uses the resident font rather than downloading the TrueType font. If you are using a TrueType font that is not equivalent to an Elite 12ppm resident font, the TrueType font is automatically downloaded.

Windows

TrueType fonts are automatically installed with Windows and are set to automatically download by default. Refer to the Windows documentation for more information.

Downloading fonts from a Macintosh

In addition to the fonts that come with the Elite 12ppm, you can purchase more fonts (both TrueType and Adobe Type 1) and download them to the Elite 12ppm. A downloaded font is a printer font that is sent by the Macintosh to the RAM located in the Elite 12ppm.

There are two methods for downloading fonts: automatic and manual.

Downloading fonts automatically

If a font being used is not one of the printer's resident fonts (i.e., nonresident font), it is automatically downloaded to the printer's RAM during each print job. After printing is complete, the font is removed from the printer's RAM. This method of downloading fonts is useful if you are printing a variety of fonts within several print jobs. However, if you are printing the same font repeatedly, this method is inefficient because the font must be downloaded for every print job.

Downloading fonts manually

If you frequently use the same nonresident fonts, manually downloading them to the printer's RAM is faster than having them download automatically each time they are used in a document. To manually download fonts, use the **LaserWriter Utility** included with the Elite 12ppm software. The LaserWriter Utility is located in the Elite™ 12ppm Folder that was copied onto your startup disk during the initial installation.

When a font is downloaded to the printer's RAM, it remains in RAM until the printer is switched off. (If other users on the network have the screen font but do not have the outline font, the outline font can still be used as long as it remains in the printer's RAM.) Since each manually downloaded font uses some of the printer's RAM, you are restricted in the number of fonts that can download by the amount of RAM available in the printer (the more RAM in the printer, the more fonts you can download). However, using a large amount of RAM to download fonts can affect the performance of the printer when processing large or complex print jobs. If you frequently use many nonresident fonts in your documents you may want to attach a dedicated font storage hard drive to the printer.

To manually download fonts using the LaserWriter Utility:

1. **Make sure the printer that you want to download fonts to is selected in the Chooser.**
2. **Double-click the LaserWriter Utility icon.**

The introduction window appears, along with a message indicating that the LaserWriter Utility is checking the characteristics of the printer.

3. Choose Download Fonts from the File menu.

The font downloading dialog box appears. The top section indicates the location to which the fonts should be downloaded. The Printer radio button is selected to download fonts to the RAM inside the Elite 12ppm.

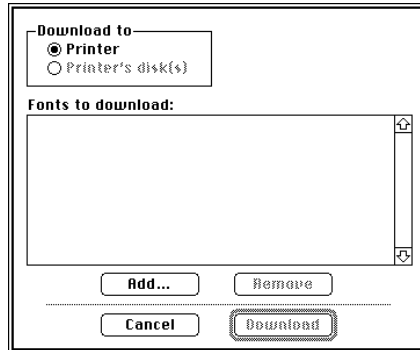

4. Click Add.

A directory dialog box appears. If the font file list does not appear, click the Desktop button to search for the list of printer font files.

5. Click the name of a font and then click Add for each font that you want to download.

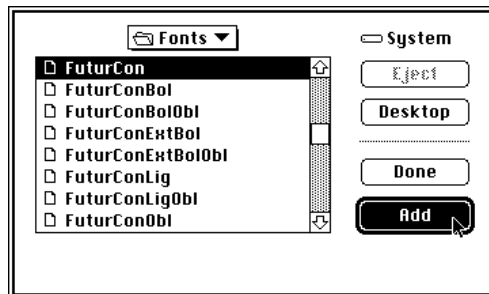

6. Click Done.

The original font download window reappears listing the selected font files. To deselect a font file, click the name of the font and click Remove.

7. Click Download.

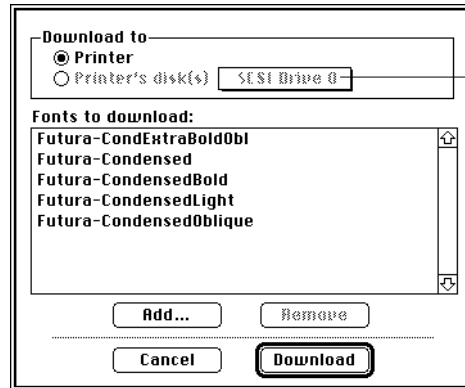

If you have a font storage hard drive(s) connected to your Elite 12ppm the Printer's disk(s) button and accompanying pop-up menu will be active. Click the button to download fonts to an external disk and choose the SCSI Drive number corresponding to the disk you want to download the selected fonts onto.

Note: If you are using a downloaded font, install the corresponding screen font on the Macintosh.

Additional LaserWriter Utility functions

The LaserWriter Utility provides a number of additional functions through its menus.

■ File menu functions

Choose:

Display Available Fonts to display a list of fonts stored in the printer's RAM (both resident and manually downloaded) or fonts stored on an external hard disk attached to the printer.

Initialize Printer's Disk to initialize an external hard disk attached to the printer.

Print Font Catalog to print a list of the fonts available in the printer's RAM and on an external hard disk.

Print Font Samples to print a sample of each font available in the printer's RAM and on an external hard disk. If you are using an external hard disk and it contains a large number of fonts, the printer may run out of memory when using this option. As an alternative, use the Font List option available from the Info Pages menu to print a list of fonts.

Note: If you want to change the printing parameters of the font catalog or font sample page, use the **Page Setup** menu command.

■ Utilities menu functions

Choose:

Name Printer to rename your printer.

Set Startup Page to turn the printer's start page On or Off. This option corresponds to the Start Page submenu in the front panel of the Elite 12ppm. For example, if you turn off the start page in the LaserWriter Utility, the Start Page option in the display window on the front panel will be set to Disabled. (The Elite 12ppm's default is Enabled.)

Get Page Count to display the total number of pages printed by the Elite 12ppm.

Download PostScript File to send a PostScript file directly to the printer.

Restart Printer to restart the printer between print jobs. This is useful for clearing downloaded fonts from the printer's memory and is preferable to switching the printer off and on again, as it will not interrupt another print job.

Downloading fonts from Windows

■ Type 1 fonts

Type 1 fonts are automatically downloaded to the Elite 12ppm. These fonts are deleted from the printer's RAM when the print job is complete. However, you may want to keep downloaded fonts in the printer's RAM for successive print jobs. To maintain Type 1 fonts in the printer's RAM, manually download the fonts using the font downloading utility included with your Type 1 font package. Manually downloaded fonts remain in the printer's RAM until you switch off the Elite 12ppm.

Note: If your normal routine is to download several fonts to the printer, it is a good idea to adjust the Windows printer driver's virtual memory setting so that it can better process your documents. Perform the procedure after you have downloaded your normal set of fonts to the printer.

■ TrueType fonts

While you can download TrueType fonts to the Elite 12ppm, Windows does not recognize TrueType fonts as resident fonts. Therefore, the TrueType fonts will still be downloaded from the PC at print time.

Using an external hard disk with the Elite 12ppm (*1200 dpi model only*)

The Elite 1212 provides a SCSI port for connecting up to seven external SCSI hard disks. These disks are used to store additional PostScript and TrueType fonts. Using an external disk for font storage is faster than downloading from the computer and it leaves more available memory, which improves performance. Fonts can be downloaded from Macintosh and Windows systems.

You use a SCSI-1 or SCSI-2 hard drive. The size of this drive doesn't have to be large. Fonts typically require around 50 Kb each, so a 20MB drive would be able to hold hundreds of fonts.

There are several guidelines that must be followed when using the SCSI cable system with the Elite 12ppm:

- When connecting the SCSI devices, make sure all devices are switched off.
- The SCSI system can only have a maximum of two terminators. If you are connecting one hard disk to the printer, you will need one terminator for the hard disk unless it is internally terminated. If two or more hard disks are to be connected to the printer, connect a terminator to the first and last hard disks in the chain, unless they are internally terminated.
- Use a PowerBook® (HDI-30) to SCSI cable to connect the first external hard disk to the Elite 12ppm. If you have trouble purchasing this cable, you can get it direct from GCC.
- If you are connecting multiple hard disks to the Elite 12ppm, make sure that each hard disk has a unique SCSI ID, and that the SCSI ID is not #7.

Note: The SCSI IDs of hard disks connected to the printer do not affect the SCSI IDs of any SCSI devices connected to a Macintosh or PC.

To connect an external hard disk to the printer:

- 1. Switch off both the hard disk and the Elite 12ppm.**
- 2. Connect the HDI-30 end of the SCSI cable to the SCSI port on the Elite 12ppm, which is located on the back of the printer.**
- 3. Connect one terminator to the SCSI port on the back of the hard disk (if it does not have built-in termination), and fasten the clips.**
- 4. Connect the 50-pin end of the SCSI cable to the SCSI port on the back of the hard disk and fasten the clips.**
- 5. Switch on the hard disk first, wait 15 seconds, and then switch on the printer.**

When a hard drive is attached to the printer, make sure that the drive is powered on before powering on the printer. Otherwise, either the hard drive will not be recognized or the printer will not initialize.

Note: Some hard drives issue a Unit Attention (UA) message when they are first accessed by the printer. The UA message conflicts with the Elite 12ppm's startup procedures, causing the drive not to be recognized. To eliminate this problem switch the printer off and back on again with the drive still powered on. This procedure will need to be used each time the hard drive is switched off and then on again.

6. Print a Start Page or Configuration page.

Information will appear on both of these pages regarding the hard disk. If the disk has not been initialized, the status information will not reflect the additional space. (See the Control Panel section on this CD-ROM for information about printing the Configuration Page.)

Initializing an external hard disk

Each hard disk connected to the printer must be specifically initialized for storing fonts. Once the hard disk has been initialized for font storage it cannot be used for any other purpose without first reinitializing it with specific formatting software. Refer to the documentation included with the hard disk.

■ Initializing hard disks from a Macintosh

To initialize the hard disk from a Macintosh, use the LaserWriter Utility included with the Elite 12ppm software. The LaserWriter Utility is located in the Elite™ 12ppm Folder that was copied onto your startup disk during the initial installation.

WARNING: If you initialize your SCSI hard disk, you will lose any data that is currently on that hard disk.

To initialize external hard disks:

- 1. Make sure the Elite 12ppm is selected in the Chooser.**
- 2. Double-click the LaserWriter Utility icon.**

A dialog message appears, indicating that the LaserWriter Utility is checking the characteristics of the printer. Then, the LaserWriter Utility menu bar appears.

- 3. Choose Initialize Printer's Disk from the File menu.**

A dialog box appears with two options: “Initialize all disks” and “Initialize some disks”. If you click the button next to “Initialize all disks”, the boxes next to the SCSI ID numbers are dimmed (A). This option will initialize all hard disks attached to the printer’s SCSI chain. If you click the button next to “Initialize some disks”, the check boxes representing the SCSI ID numbers of any hard disks connected to the Elite 12ppm are highlighted: (B) shows an external hard disk at SCSI ID 1.

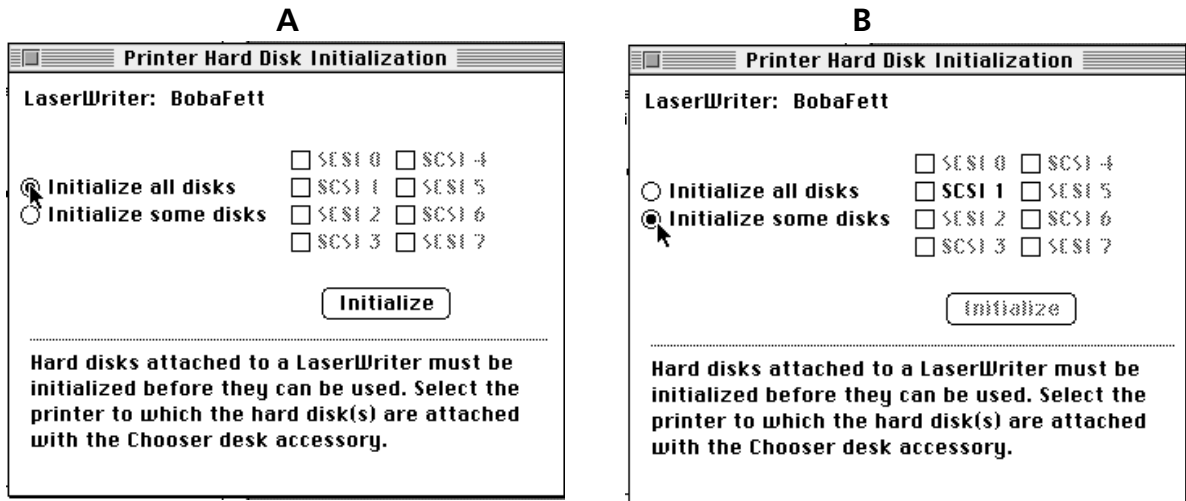

If you are attaching more than one hard disk to the printer, we recommend that you always use the “Initialize some disks” option, and that you initialize each hard disk separately before chaining them together.

4. Click the button labeled **Initialize some disks**.
5. Click the box next to the SCSI ID of the first hard disk to be initialized.

An X appears in the box and the Initialize button becomes active.

6. Click **Initialize**.

A dialog appears asking if you really want to initialize this hard disk. Click OK to proceed, or click Cancel. A progress status box appears.

7. Click **OK**.

If the initialization fails, repeat the initialization steps. If the initialization was successful, repeat the steps for each additional hard disk.

8. Use the **LaserWriter Utility** to download fonts to the hard disk(s).

■ Initializing hard disks from an IBM PC or compatible

To initialize an external hard disk connected to the Elite 12ppm using an IBM PC or compatible, use the INITDISK.PS file provided on the Printing Software for Windows floppy disk. When sent to the printer, this file will initialize any uninitialized hard disks connected to the printer.

For example, if the printer is connected to the first parallel port,

```
Type: copy /b a:\initdisk.ps lpt1:
```

If the printer is connected to the first serial port,

```
Type: copy /b a:\initdisk.ps com1:
```

10: Maintenance and Troubleshooting

Your Elite 12ppm is exceptionally easy to maintain. Wipe the outer surfaces of the printer's case with a damp cloth from time to time to remove dust. Do not use ammonia or alcohol-based cleaners on or around the printer.

Cleaning the rollers every 12,000 pages

In order to assure smooth paper transport GCC recommends that you check the rollers in the following illustrations and clean them if necessary with a damp cloth. Do this at alternate toner cartridge changes (approximately 12,000 pages).

The rollers are (from left to right) at the back of the paper output tray, inside the cover at the rear, and inside the paper tray housing. You'll need to remove the paper tray to get at this roller.

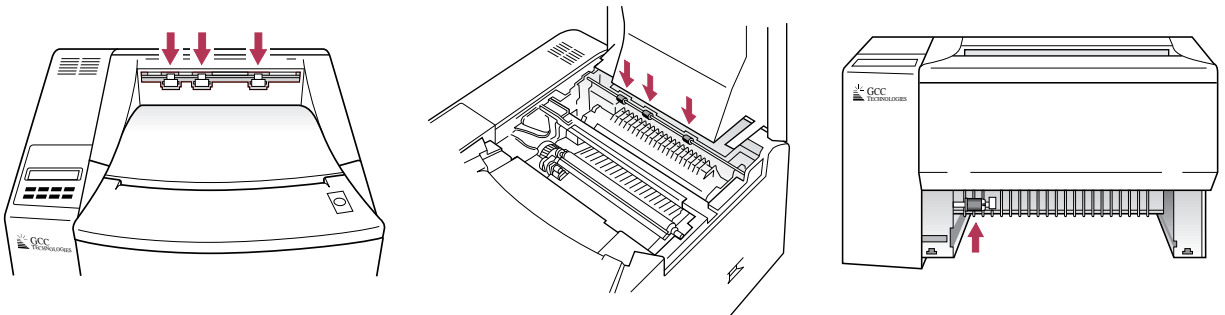

Handling and storing toner cartridges

The toner cartridge contains not only the toner itself but also a photoreceptive drum and other electrostatic components. Handle it carefully. Don't remove the toner cartridge from its box until you are ready to use it. Place the cartridge flat and with the handle up. Don't tamper with the components within the toner cartridge.

When you store a cartridge properly, it has a shelf life of two years. Don't store the cartridge on end or upside down. Keep the box away from direct sunlight or strong room light. Keep the temperature within 0-35 degrees Celsius (32-95 degrees Fahrenheit).

Toner spills

Wipe small toner spills with a damp cloth. Don't use hot water; you may set the toner and cause stains on clothing and furniture. Wash your hands in cold water. You should remove larger amounts of spilt toner with a vacuum cleaner. If you spill very large amounts inside the printer, contact your GCC Technologies dealer or authorized service provider for cleaning.

Packing the printer to transport it

Warning: If you are returning the printer to GCC or its dealers or distributors for any reason, first contact GCC technical support at 781-276-8620 (U.S. only) or your local GCC dealer or distributor.

Always use the original shipping box and packing when you need to move or return your printer. If you don't have the box, you can get another from GCC.

Warning: *Always* remove the toner cartridge before packing the printer.

1. Unplug the power cord and interface cables, and remove any optional accessories.
2. Remove the toner cartridge, put it into a plastic bag, seal it well, and then place it into the box it came in.
3. Wrap the printer in the original plastic bag.
4. Place the printer into the styrofoam cutouts in the bottom of the original shipping box.
5. Place the interface cables and the power cord on top of the printer and tape them to it.
6. Place the remaining packing materials on top of the printer.
7. Tape the box shut.

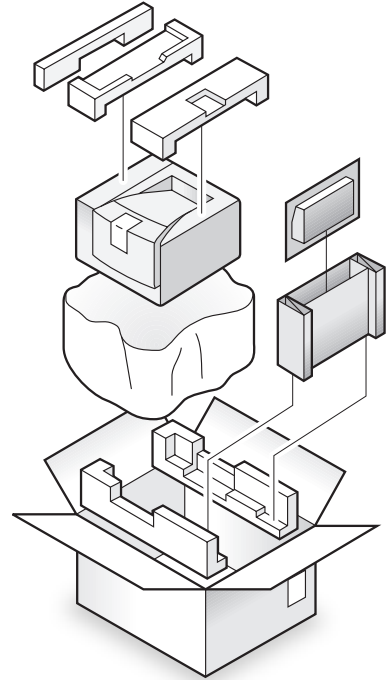

Printing Problems

Paper Jams

When a paper jam happens, the red service LED on the printer's control panel flashes and one of three messages appears in the display. The messages are:

- Paper feed jam
- Paper path jam
- Paper exit jam

You must clear the jam, and open and close the printer's top cover to reset the printer and resume printing.

Paper feed jam

This usually happens when paper is misfed from the paper tray. If you remove the paper tray you should see a loose sheet of paper.

Paper path jam

This happens when paper is being moved past the toner cartridge. If you remove the toner cartridge you should see the jammed paper.

Paper exit jam

This happens when a printed sheet jams as it exits the printer. The jammed paper should be partly visible exiting the printer into the output tray on top of the printer.

Clearing a paper jam

1. Open the top cover of the printer.
2. Locate the jammed paper. If the message says Paper feed jam, open the paper tray; if the message says Paper path jam, remove the toner cartridge.
3. Grasp the jammed paper with both hands and slowly remove it from the printer by pulling in the direction that the paper normally takes. If the sheet tears, make sure you remove all the pieces.
4. Discard the jammed paper. If the jam happened at the paper tray, be sure that all the paper is beneath the metal bracket at the left front of the paper tray.
5. Check the list below: "Paper Jam Checklist."
6. Replace the paper tray in the printer (if necessary) and close the top cover of the printer.

After a minute or so the printer will warm up and resume printing.

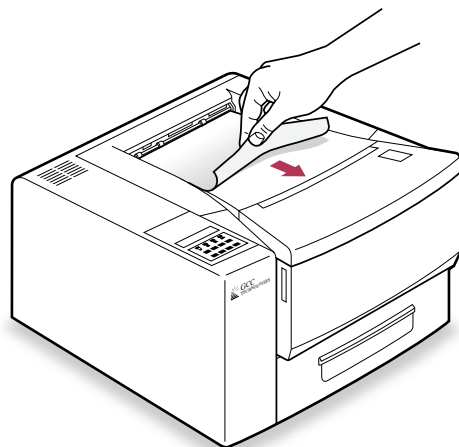

Paper Jam Checklist

- Did you remove all the packing from inside the printer when you set it up?
- Is the paper flat and dry?
- Have you removed the stack of paper and fanned it to make sure that pages are free to move?
- Are the paper's edges flush?
- Is the paper under the brackets in the paper tray?
- Is there too much paper in the paper tray? The 250-sheet limit for the standard paper tray is for 20 lb. (75 g/m²) sheets.
- Are you using the Multipurpose feeder and the rear output for heavy sheets and envelopes?
- Are the paper length and width guides in the paper tray correctly adjusted?
- Is the paper width guide in the paper tray next to (but not tight against) the paper?
- Is the paper in the tray the same size as in the Page Setup dialog box of your application?
- Have you removed all traces of paper from previous jams?
- Is the paper path free from any obvious obstructions?

Other printer problems

Some problems with printing can really be problems with applications. Typical application problems include:

- A graphic appears on my screen, but when I print only the text shows (Try copying the graphic to a separate page and print that page only).
- The quality of fonts is very poor (usually a problem with Macintoshes that only have screen fonts installed; install the printer fonts).
- The computer crashes when I print a document (try printing another document from that application; if this prints successfully, this probably means that the original document is corrupt).

You may have problems related to printer or system setup:

- The printer is not listed as available (the printer may not be on line, the printer software is not installed correctly, or any network connection to the printer may be having problems).

Problems with the printer itself

Typical problems which are directly related to the printer include:

- The printer is not available (there's probably some error at the printer; check the control panel to make sure that the printer is on line and not displaying any error message).
- Output is gray rather than black, or there's nothing on the page at all (the toner cartridge is almost empty or completely empty).
- Random areas of the page are blank, or have marks on them (often this means that the toner cartridge is damaged; try replacing it).

Detailed Troubleshooting

Your GCC printer is designed to perform smoothly and reliably. It passed rigorous quality standards and tests before being shipped to you. Despite these qualification standards, on rare occasions you may experience a problem with the printer's operation. This section of the manual is provided to help when a problem occurs. The following pages contain solutions for common problems. If you need help, call your dealer or GCC Technical Support at (781) 276-8620. Subjects covered include:

- Chooser problems
- LocalTalk problems
- Serial and Parallel communications problems
- Ethernet communications problems
- Macintosh system crashes
- Macintosh font problems
- PostScript problems
- PCL problems
- Front panel messages
- Clearing paper jams
- Poor quality output

■ Chooser problems

If there is no Chooser under the Apple menu:

- If you are using System 6.0.x or lower, use Apple's Font/DA Mover to install the Chooser into the System file of your startup disk. This desk accessory is part of your Apple System Software.
- If you are running System 7.0.x or higher, the Chooser needs to be in the Apple Menu Items folder in the System Folder. A copy of the Chooser is located on the system floppy disks that came with your Macintosh. See Apple's documentation if you need assistance in reinstalling the Chooser.

If the LaserWriter 8 icon does not appear in the Chooser, try the following:

1. Insert the Elite 12ppm CD-ROM.
2. Run the Elite™ 12ppm Installer.
3. From the lower portion of the file installation area highlight LaserWriter 8 and click Install.
4. Turn off QuickDraw GX.

If the name of your Elite 12ppm does not appear in the "Select a LaserWriter" scroll box after selecting the LaserWriter 8 icon:

- Check the On Line status LED on the printer's control panel; it should be solid.
- Check the control panel display window for an error message.
- Check LocalTalk or Ethernet (if available) network cables and connections.
- Set the printer's control panel 8-pin Serial submenu item to LocalTalk.
- In the Chooser, make sure that the LaserWriter 8 icon is highlighted in the left scroll box and verify that AppleTalk is Active.
- If there are zones in your AppleTalk network, make sure the zone you select in the Chooser is the zone where the printer is located. If no zone names appear in the Chooser, there may be a network problem. Check to see that all devices are properly connected to the network.

■ LocalTalk problems

If your document does not print and a message appears on your Macintosh screen stating that the printer could not be found, check the following regarding the LocalTalk network system:

- Check the On Line status LED on the printer's control panel; it should be solid.
- Check the control panel display window for an error message.

- Set the control panel 8-pin Serial submenu item to LocalTalk.
- In the Chooser, make sure that the LaserWriter 8 icon is highlighted in the left scroll box and verify that AppleTalk is Active.
- Check the LocalTalk connection by following the instructions in the section on connecting to LocalTalk in the section on connecting to a Macintosh. Verify that all devices are connected properly and that the network has a beginning and an end.
- Make sure that all computers on the network are using the same version of the Elite 12ppm software.
- If the printer is in a different zone from the computer, check the AppleTalk bridge.
- Restart the printer. The printer's control panel should indicate that the printer is Ready.

If you print to one Elite 12ppm and the page prints to a different printer on the network, switch each printer off and then on again. Printing to a different printer can occur if two printers occupy the same LocalTalk address.

■ **Serial and parallel communication problems**

If the Elite 12ppm does not print, there may be a problem with the setup or configuration. Check the following:

- Check the **On Line** status LED on the printer's control panel; it should be solid.
- Check the control panel display window for an error message.
- If you are using the RS-422 serial interface, verify that the 8-pin Serial submenu item is set to RS-422. Restart the printer. The control panel should indicate that the printer is Ready. Also verify the RS-422 Serial submenu item settings. They should match the settings in the Windows Settings box available from the Connect box of the Printers control panel.
- Check all connections following the instructions in the section on connecting the printer to a PC using the parallel or serial interface.
- Verify that your Windows software and/or your DOS application software is configured to print to the correct port on the computer.
- For DOS printing, make sure the correct MODE statements are in your AUTOEXEC.BAT file.
- For PostScript printing, make sure that the Elite 12ppm printer driver is selected.

■ Ethernet communication problems

When you connected the Elite 12ppm to an Ethernet cabling system, the printer should have been switched off to avoid connection problems. Before continuing with these troubleshooting procedures, switch the printer off, wait ten seconds, and then switch the printer on.

If the printer will not print:

- Switch off the printer. Switch the printer back on and at the same time watch the LED between the two Ethernet ports (labeled TX/RX). The LED should flash for a few seconds. If the LED flashes, the network card is probably operating correctly and the problem might be with your network.

Note to network administrator: As a test of the printer's ability to receive data over the network, you can send echo packets to the printer. This should cause the center LED to flash. Normal print jobs will not cause the center LED to flash.

If your Elite 12ppm is connected to a 10BASE-2 network:

- Verify that a UTP (unshielded twisted-pair) cable is not connected to the UTP connector. (The Ethernet adapter will acknowledge the UTP connection instead of the coax connection.)
- Verify that the Ethernet cable has a 50 ohm terminator connected at each end.
- Verify that the Ethernet cable is not connected in a loop configuration. The cable should be connected as a "linear bus" in which one piece of coax cable is connecting all the nodes.

If your Elite 12ppm is connected to a 10BASE-T network:

- Verify that the printer is connected to a UTP hub on the other end.
- Verify that the cabling is correctly constructed. The cable should be constructed with a data grade twisted-pair 2-pair, 3-pair, or 4-pair cable. There should be at least six twists per foot. Do NOT use straight 25-pair or 50-pair phone cables (this cable does not meet the criteria set for UTP cables, and will cause communication errors).

If the Elite 12ppm printer name does not appear in the right scroll box after selecting the LaserWriter 8 icon in the Chooser:

- Verify that the correct zone is selected. Ethernet and AppleTalk connections may appear in different zones.

■ Macintosh system crashes

If your Macintosh system crashes while a document is printing, try the following:

- Restart the printer. Print the document again.
- If Background Printing is on, turn it off; try printing the document again.
- Reinstall the printer software following the instructions in the Macintosh section of this CD-ROM.
- Print a different document from the same application. If one document from an application causes a crash while others do not, the document may be corrupt. Replace the document.
- Remove (or disable) INITs (Extensions), temporary files, and non-System software files (such as a Preferences file or a Defaults file) from the **System Folder**.
- Print from a different application; if all documents from a particular application cause crashes, replace the application, along with any application-specific Default and Preferences files. Refer to the application's documentation for more information. If documents from different applications cause crashes, you may need to replace your System and Finder files. Refer to Apple's documentation for more information.

■ **Macintosh font problems**

If the fonts printed on the Elite 12ppm appear to be low-quality screen fonts rather than high-quality resident fonts:

- Make sure that the **Elite 12ppm Screen Fonts** are in the appropriate location in the **System Folder**. Note that with the **Font Substitution** option off, only screen fonts for which there are corresponding resident fonts print at high quality. (An exception to this is if you have TrueType or Type 1 high-quality (printer) fonts installed on your Macintosh.) With **Font Substitution** on, some screen fonts will have high-quality fonts substituted for them, even if there is no corresponding high-quality font. (For example, Times will be substituted for New York, Helvetica for Geneva, and Courier for Monaco.)
- If you are using a nonresident font that is downloaded from your computer, make sure the font file to be downloaded is either in the **Fonts** folder (System 7.1 or later), the **Extensions** folder (System 7.0.x), or the **System Folder** (System 6.0.x) of the startup disk; the printer's RAM; or the printer's internal hard disk. As you print, a message appears on the screen of your Macintosh indicating which fonts are being downloaded.
- Some applications have an option called **Fractional Character Widths**. In some applications, if this option is enabled, **Font Substitution** has no effect.

- If you are using downloaded fonts, make sure you download all the styles of fonts, such as bold, italic, and bold italic. If you do not, your document will print with plain style fonts.
- Deselect the **Unlimited Downloadable Fonts in a Document** option in the Page Setup dialog box.

■ **PostScript problems**

If your PostScript print jobs print incorrectly check the following:

- Make sure the correct printer driver is chosen: for Windows, choose Elite 12ppm, for Macintosh choose LaserWriter 8.
- Be sure the PS/PCL Sensing menu in the front panel is set to either PostScript Only or Auto Switch.
- Depending on the application and the complexity of the print job, you may need to increase the Wait timeout value in the front panel. If the wait timeout is too short, jobs may print either partially or not at all.
- If you are printing from a Macintosh try printing with Background Printing turned off.
- Try restarting the printer.

■ **PCL problems**

If your PCL print jobs print incorrectly check the following:

- Be sure the PS/PCL Sensing menu in the front panel is set to either PCL or Auto switch.
- Make sure that the LaserJet III driver is installed and selected in your application.
- If the print jobs do not print at all or only partially, try setting the Wait Timeout setting higher.

Each line of text repeats on the same line:

- Change the Line Termination submenu item to CR=CRLF.

The next line of text starts below the end of the previous line (stairstep effect):

- Change the Line Termination submenu item to LF=CRLF;FF=CRFF.

Diagnosing errors from print output

“Recommended paper” in these examples is 20-pound (75 g/m²) copier-type paper.

The print is light or faded:

- Moisture in paper – load fresh, dry paper.
- Print density is incorrectly set – adjust the print density
- Toner cartridge is low on toner – replace toner cartridge
- Toner cartridge is damaged – replace toner cartridge

Toner spots are randomly scattered across the page:

- Paper doesn't meet specification – use recommended paper
- Toner cartridge is damaged – replace toner cartridge

Repeating marks spaced evenly on page:

- Paper path is dirty – print some blank sheets to clear the paper path
- Toner cartridge is damaged – replace toner cartridge

Light or faded areas within the print:

- Transfer roller smudged – print some blank sheets of paper
- Moisture in paper – load fresh, dry paper
- Paper doesn't meet specification – use recommended paper

Light or faded vertical bands running through print:

Data sent to printer

Press the ON-LINE button to take the does not print, but printer off-line, then press the FORM FEED DATA PRESENT button to eject the final page or send the message appears. Form feed code (decimal character 12). Last page of Press the ON-LINE button to take the does not print, but printer off-line, then press the FORM FEED DATA PRESENT button to eject the final page or send the message appears. Form feed code (decimal

Data sent to printer

Press the ON-LINE button to take the does not print, but printer off-line, then press the FORM FEED DATA PRESENT button to eject the final page or send the message appears. Form feed code (decimal character 12). Last page of Press the ON-LINE button to take the does not print, but printer off-line, then press the FORM FEED DATA PRESENT button to eject the final page or send the message appears. Form feed code (decimal

Data sent to printer

Press the ON-LINE button to take the does not print, but printer off-line, then press the FORM FEED DATA PRESENT button to eject the final page or send the message appears. Form feed code (decimal character 12). Last page of Press the ON-LINE button to take the does not print, but printer off-line, then press the FORM FEED DATA PRESENT button to eject the final page or send the message appears. Form feed code (decimal

Data sent to printer

Press the ON-LINE button to take the does not print, but printer off-line, then press the FORM FEED DATA PRESENT button to eject the final page or send the message appears. Form feed code (decimal character 12). Last page of Press the ON-LINE button to take the does not print, but printer off-line, then press the FORM FEED DATA PRESENT button to eject the final page or send the message appears. Form feed code (decimal

- Toner distributed unevenly – remove the cartridge and rock it back and forth a few times
- Toner cartridge is damaged – replace toner cartridge

The entire page is black or partially black:

- Toner cartridge is damaged – replace toner cartridge
- Mechanical malfunction – call for service

The entire page is blank:

- The toner cartridge seal is still in place – remove the cartridge and remove the seal
- Multiple sheets were fed – fan the paper in the cassette
- The toner cartridge is low on toner – replace toner cartridge
- The toner cartridge is damaged – replace the toner cartridge
- Mechanical malfunction – call for service

Print rubs off or smears:

- Moisture in paper – load fresh, dry paper
- Paper doesn't meet specification – use recommended paper
- The printer access door isn't fully closed – make sure it's fully closed and latched

If your problem wasn't covered by these examples, or the solutions don't solve your problem, contact GCC Technical Support.

Solving problems by turning the printer off and on again

Sometimes you make changes at the printer's control panel and these changes appear to have no effect. Some changes do not take effect until you've *cycled* the printer — that is, turned it off and on again.

At other times, you can make changes with WebAdmin or the NEST tool, and these require that you cycle the printer.

Data sent to printer

Press the ONLINE button to take the page off-line, then press the FORM FEED DATA PRESENT button to eject the final page or send the message appears. Form feed code (decimal character 12). Last page of Press the ONLINE button to take the page off-line, then press the FORM FEED DATA PRESENT button to eject the final page or send the message appears. Form feed code (decimal



Data sent to printer

Press the ONLINE button to take the page off-line, then press the FORM FEED DATA PRESENT button to eject the final page or send the message appears. Form feed code (decimal character 12). Last page of Press the ONLINE button to take the page off-line, then press the FORM FEED DATA PRESENT button to eject the final page or send the message appears. Form feed code (decimal

If the “Service Required” message appears in the control panel, we recommend that you turn the printer off, leave it for 5 minutes, and then turn it on again. If the Service Required message doesn’t reappear, you can carry on printing. If the message is still displayed, contact GCC Technical Support at 781-276-8620.

There’s a rare possibility that the printer’s internal software may have a problem. Cycling the printer will normally clear this. If problems persist, contact GCC Technical Support.

Service and Support

You can contact GCC for technical assistance in several ways.

- Technical Support phones: 781-276-8620.
- Fax: 781-275-1115.
- GCC's World Wide Web site: www.gcctech.com
- Internet email: support@gcctech.com
- CompuServe: GO MACBVEN, DL2.
- CompuServe email: GCCTech@compuserve.com.

GCC's World Wide Web site

GCC's Web site offers a wealth of information. The full manual for the Elite 12ppm series of printers is here, along with technical bulletins that deal with any problems that arise over the life of your printer. Check www.gcctech.com to see if your problem has a solution.

Dealer and Service Center support

GCC offers worldwide services from its dealers and service centers. Dealers and service centers are supported by training, technical documentation, and technical support.

Extended warranties

GCC offers extended warranty programs for all its products. These extend the limited warranty and cover all parts of the printer (except consumables, like the toner cartridge). You can purchase an extended warranty during the limited warranty period, and renew it year after year.

Software upgrades

You can download software upgrades from GCC's web site or from its section on CompuServe.

Transporting your printer

Full instructions on packing the printer for transport are on page 10-2 in this section. *Always* remove the toner cartridge from the printer before transporting it.

Consumables, accessories, and upgrades

You can purchase consumables such as toner cartridges, accessories, and upgrades from GCC dealers or direct from GCC itself, by calling 800-422-7777 (U.S. only). A list of consumables and accessories is in appendix I.

11: Adobe Acrobat

The installation guide has details of how to set up Adobe Acrobat on your computer's hard disk or on a network. Your computer has been configured for Acrobat, otherwise you wouldn't be able to read this.

Installation information is repeated here in case you want to configure the CD-ROM on another computer and cannot find the Quick Installation guide (the paper manual).

This CD-ROM contains full information about your printer, in Adobe Acrobat format files. Part of this information is in the Quick Installation guide, but this CD-ROM has all the information about the printer, including all the information in the Quick Installation guide.

This CD-ROM comes with Macintosh and Windows versions of the Adobe Acrobat Reader program; you can install this program on a computer and read the documents on this CD-ROM. Providing that you have sufficient free hard disk space (about 50 MB), you can copy the data files to a computer and be able to use the manual without the CD-ROM.

The Acrobat reader can read a file and display it on your Macintosh or Windows computer. You do not have to have any of the fonts used in Acrobat documents installed on your computer; the program will display and print the fonts, but will not install them in your computer.

You can print pages from Acrobat documents, and also copy and paste text from Acrobat files into other applications, and make full text searches within the document.

Installing Adobe Acrobat Reader

1. Put the Elite 12ppm CD-ROM in your CD-ROM drive.
2. (Windows only) Open File Manager (Windows 3 and NT 3.51) or Explorer (Windows 95 and NT 4.0).
3. Open the Folder or Directory of the CD-ROM called Manuals.
4. Open the Folder or Directory that corresponds to your language. Languages available for the Acrobat program are English, French, Italian, German, and Spanish.
5. Run the program called Acroread.mac (Macintosh) or Acroread.exe (Windows). This installs the Reader program; follow the instructions on the screen.

Opening Documents with Acrobat Reader

Acrobat documents are stored as Portable Document Format (.pdf) files. Open them in the same way as you open files in other applications.

Understanding the Acrobat Screen

The Acrobat screen is divided into two parts; *bookmarks* on the left and *pages* on the right. Treat the bookmarks as a table of contents. If a bookmark has a triangle to the left of it, you can click on the triangle to show a list of subtopic bookmarks. Click on the triangle again to hide the subtopics. If you click on a bookmark, you'll jump to the first page in that section. There is a scroll bar at the bottom of the bookmarks so that you can see all the text in a bookmark.

Depending on the size of your computer's screen, you may need to magnify the page. You can choose the magnification you want by clicking on the magnification box in the status bar at the bottom center of the screen.

- Fit Page shows the entire height of the page.
- Fit Width shows the entire width of the page. You won't be able to see some of the top or bottom of the page.
- Fit Visible is similar to Fit Width, but shows the width of the page between margins.

You can also choose percentage views from the list, or choose Other to create a specific percentage view. You can also use the magnifying glass button in the toolbar to drag over an area of the page you want to enlarge.

When you change the magnification it remains at that setting for all pages until you change it again.

Moving Through Pages

You can move forward and backward through the sections of the Elite 12ppm manual by dragging the vertical scroll bar. When you do this you'll see a window telling you which page you're selecting.

If you click in the background area of the vertical scroll bar you'll move one page at a time. If the magnification you've chosen shows less than a full page, you'll see the top part of each page followed by the bottom part.

You can also use the toolbar buttons to move from page to page.

This manual has a table of contents with underlined entries in red; click on these to go to that section of the manual.

Finding Text

Just as you can think of the bookmarks as a table of contents, the Find tool takes the place of an index. If you want to find a word:

1. Click on the Find button in the toolbar.
2. You'll see the Find dialog box. Enter the word(s) you want to find.
3. Click OK; the program takes you to the next place the word appears.
4. If you don't find the information you're looking for, press Command-G (Macintosh) or Control-G (Windows) to go to the next place the word appears.

What's on this CD-ROM

This CD-ROM contains important information; please take the time to look at the various sections. These include:

- Using PostScript and PCL fonts
- A detailed troubleshooting guide
- The control panel menu system
- Networking guide
- GCC's WebAdmin tool for configuring printers remotely
- Installing and using optional equipment
- Detailed printer specifications

Keep this CD-ROM in a safe place. You can buy further copies from GCC.

Appendix A: Printer Specifications

Print Engine: Fuji Xerox P893 (Mario)

Print Method: Dry type laser printing

Languages: PostScript Level 2 compatible (Xionics PS/PLI),
PCL5 with HP-GL/2 (Xionics FIVE/PLI)

Processor: 50MHz AMD 29040 RISC

Memory: Standard memory differs with model. All models upgradeable to 64 MB

Interfaces: LocalTalk/RS-422, Centronics parallel, HDI-30 SCSI (*1200 dpi model only*),
Ethernet 10BASE-2 (*1200 dpi model only*), and 10BASE-T

Letter Print Speed: 12 pages per minute

Maximum time until first page printed: 30 seconds (plus processing time)

Height: 8.98 in. (228 mm)

Width: 16.57 in. (421 mm)

Depth: 16.34 in. (415 mm)

Weight: 27.2 lbs (12.2 kg)

Power requirements: 120 VAC (min. 108 VAC, max. 132 VAC), 50/60 Hz, maximum
5.5 amp during printing

or 230 VAC (min. 198 VAC, max. 264 VAC), 50/60 Hz, maximum 3 amp during printing

Temperature (during operation): 40 ° F - 95 ° F (5 ° C - 35 ° C)

Humidity (during operation): 15% - 85% relative humidity, non-condensing

Altitude (during operation): 0 - 8,200 feet (0 - 2,500 meters)

Noise level during operation: Less than 51 db

Noise level in standby: Less than 32 db

Toner Cartridge life: 6,000 pages (letter size with 5% coverage)

Engine life (minimum life expectancy): 300,000 pages/5 years

Maximum number of pages printed per month: 20,000

Certifications: UL/CSA/FCC/VDE, Energy Star

Font Formats supported: Adobe Type 1, Type 3, TrueType, Bitstream Speedo, AGFA Intellifont.

Universal tray/250 sheet capacity:

Letter Legal Legal 13"

Executive A4 B5

Transparencies (Letter/A4, 50 sheets maximum)

Label stock (Letter/A4, 50 sheets maximum)

Multipurpose feeder: Sizes as above with 80 sheets of paper, 40 transparencies, and 40 sheets of label stock maximum capacity. The multipurpose tray can also be used with the following envelope sizes (10 envelopes maximum):

Commercial #10 Monarch DL C5

You can also use the multipurpose tray for up to 25 postcards.

Optional Letter tray/500 sheet capacity:

Letter A4 Legal Legal 13"

Optional Envelope tray/30 envelope capacity:

Commercial #10 Monarch DL C5 Postcard

Both the above optional paper sources require that you have the optional sheet feeder.

Paper weight:

Paper trays : 16-28 lb. (60 g/m² - 105 g/m²)

Multipurpose feeder: 16-36 lb. (60 g/m² - 135 g/m²)

Paper Dimensions

Letter: 8.5 x 11 in. (215.9 x 279.4 mm)

Legal: 8.5 x 14 in. (215.9 x 355.6 mm)

Legal 13": 8.5 x 13 in. (215.9 x 330.2 mm)

Executive: 7.25 x 10.5 in. (184.2 x 266.7 mm)

A4: 210 x 297 mm (8.27 x 11.69 in.)

B5: 182 x 257 mm (7.17 x 10.12 in.)

Postcard: 3.94 x 5.83 in. (100 x 148 mm)

Envelopes

Commercial #10: 4.125 x 9.5 (104.8 x 241.3 mm)

Monarch: 3.875 x 7.5 (98.4 x 190.5 mm)

DL: 4.33 x 8.66 in. (110 x 220 mm)

C5: 162 x 229 mm (6.38 x 9.02 in.)

Print alignment

Skew: The amount by which a supposedly horizontal printed line may vary from being parallel with the edge of the paper. This assumes that vertical printed lines are also at an angle, so that the entire image is printed correctly but slightly rotated on the page. Measured with a 190 mm (7.48 inch) line.

Within 1.2 mm (0.047 inch) either up or down (normal paper tray)

Within 1.4 mm (0.055 inch) either up or down (multipurpose tray)

Registration: The amount by which images appearing to left or right, or above or below previously printed images. Images appear on the paper correctly printed and aligned, but not in the same place. Measured at the mid-point of the side or top of the paper.

Within 2.0 mm (0.079 inch) horizontal or vertical either way

Magnification: The amount by which a line can be greater or smaller than its nominal length. Measured with a 240 mm (9.45 inch) vertical line and a 190 mm (7.48 inch) horizontal line. These lines are centered on the page to avoid measuring parallelism errors.

Within 0.8 percent longer or shorter than its nominal length

Parallelism: The amount by which the ends of two vertical and two horizontal lines can be greater or farther apart than the other ends. Measured with vertical lines of 234 mm (9.21 inch) and horizontal lines 190 mm (7.48 inch). These lines are arranged to form a rectangle on the page.

Within 1.44 mm (0.057 inch) horizontal or vertical either way

Linearity: The amount that three straight lines (horizontal, vertical, and diagonal) can vary from being truly straight. One end of each of the horizontal and vertical lines meet at a corner; the diagonal line is at 45 degrees to the other two lines and passes close to the center of the paper. The horizontal line is 190 mm (7.48 inch), the vertical line is 234 mm (9.21 inch), and the diagonal line is 269 mm (10.6 inch). The amount is measured by the distance a line can vary from the position of a true straight line.

Within 0.5 mm (0.02 inch) either side, horizontal and vertical lines

Within 1.2 mm (0.05 inch) either side, diagonal line

Perpendicularity: The amount one end of a 114.5 mm (4.51 inch) vertical line can vary from true perpendicular.

Within 0.8 mm (0.03 inch) either side of true vertical

Skew

$$(-1.2\text{mm}) \leq E \leq (+1.2\text{mm})$$

or $(-1.4\text{mm}) \leq E \leq (+1.4\text{mm})$ when fed from the MBF

$$E = F - G$$

$$H = 190\text{mm}$$



Direction of Paper Travel

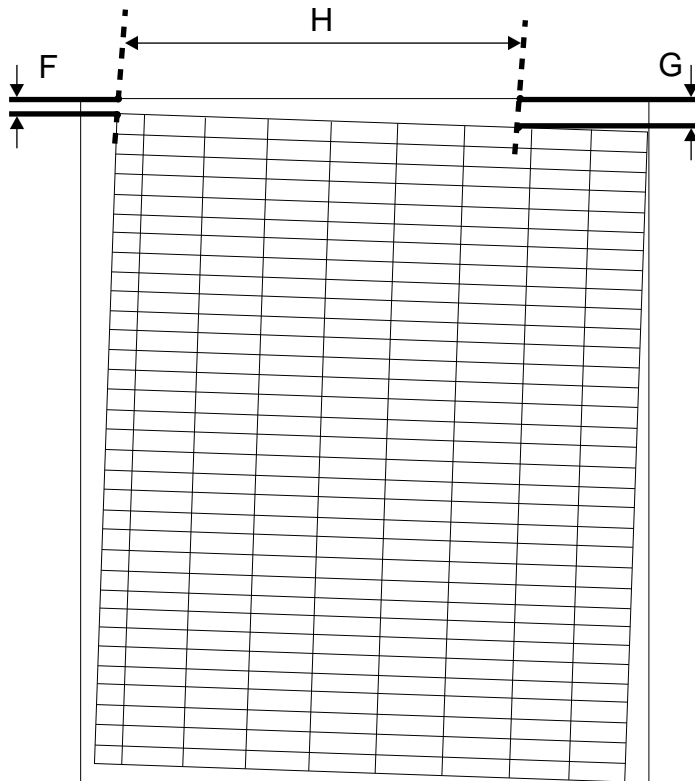

Lead edge registration

$$(4.0 - 2.0\text{mm}) \leq A \leq (4.0 + 2.0\text{mm})$$

$$B=B$$

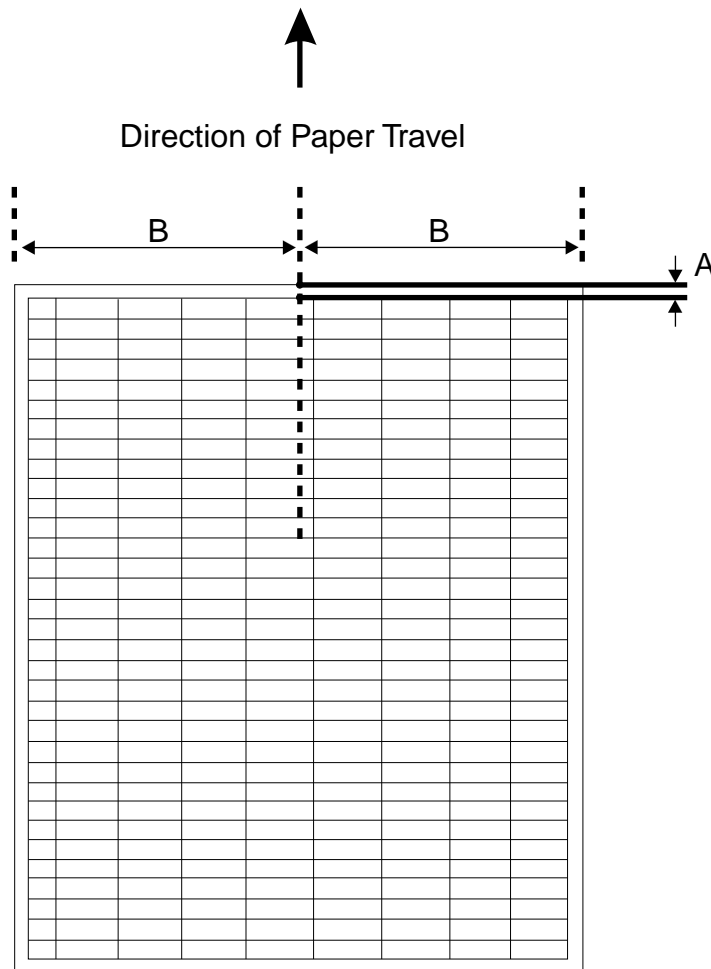

Side edge registration

$$(4.0 - 2.0\text{mm}) \leq C \leq (4.0 + 2.0\text{mm})$$

$$D=D$$



Direction of Paper Travel

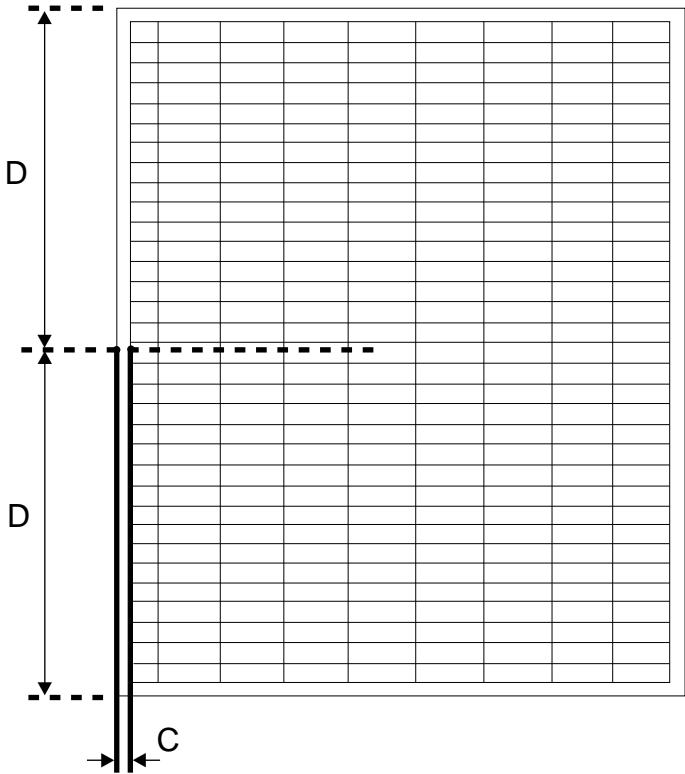

Parallelism

$$(-1.4\text{mm}) \leq T \leq (+1.4\text{mm})$$

$$T = U - V$$

$$U \geq 234\text{mm}$$

$$W \leq 190\text{mm}$$



Direction of Paper Travel

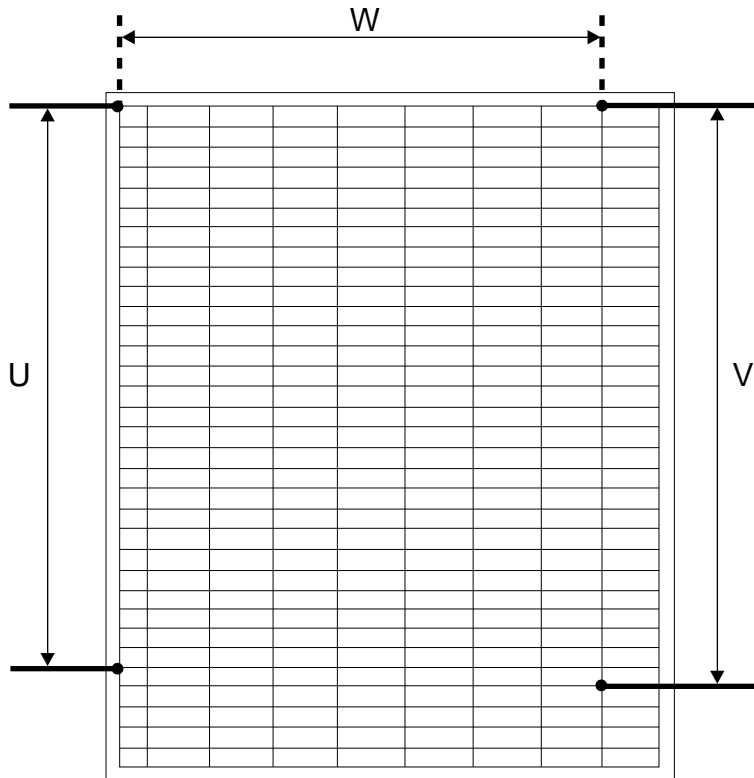

Orthogonality

$$(-0.8\text{mm}) \leq J \leq (+0.8\text{mm})$$

$$K = L$$

$$M = 114.5\text{mm}$$

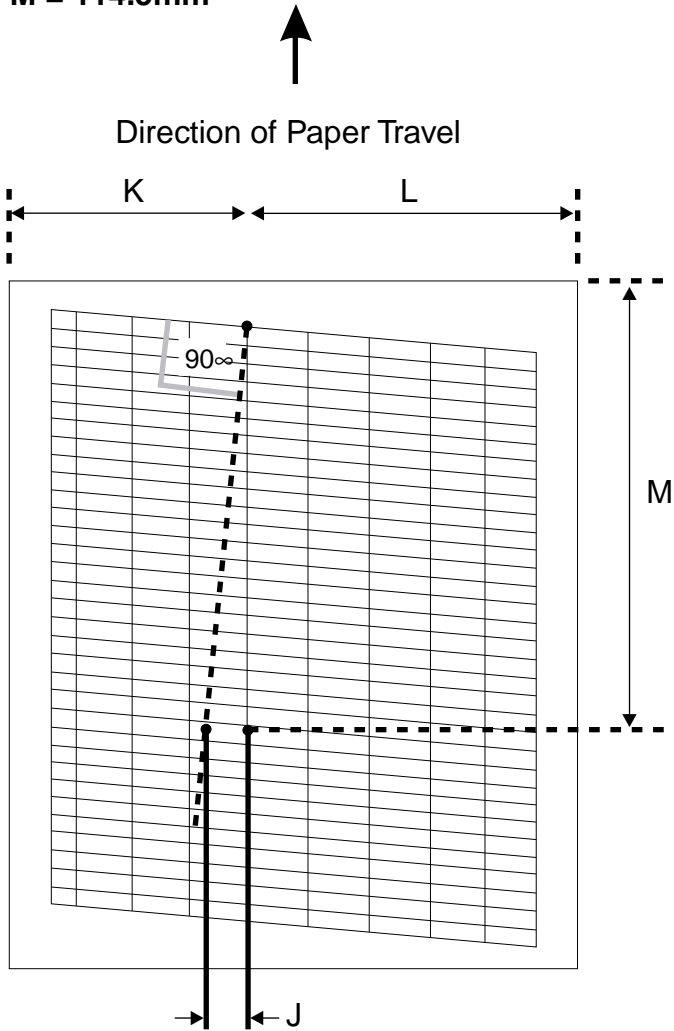

Appendix B: Paper specifications and recommendations

GCC Technologies recommends the following materials for use with your printer. GCC does not assume liability for materials used with the printer that are not listed below.

Printing on standard papers

Your GCC printer prints on most kinds of paper stock, including most color stocks and letterhead. The printer produces best results on standard 20-pound (75 g/m²) copier-type paper; however, paper weights from 16-lb. to 28-lb. (60 g/m² to 105 g/m²) should also provide good results.

To produce even clearer, sharper images, use paper with a surface that is smoother, but not shinier, than photocopy paper. Some companies offer paper specifically designed for laser printers.

Printing on letterhead

Letterhead should conform to the weight and surface characteristics specified in the previous section. Also, keep the following points in mind when printing on letterhead:

- **Temperature:** Some letterheads use low-temperature dyes that vaporize and smear at high temperatures. Many letterheads that have a slick texture use a heat bonding process called thermography that bonds the print to the paper. Letterheads produced with this technique may “unbond” in the printer, causing damage.
- **Paper Texture:** Highly textured paper may not print evenly.
- **Paper Finish:** Paper that is extremely shiny does not work well.

Printing on envelopes

Use envelopes that are smooth (but not slick) and have rectangular or square flaps (rather than a triangular flap).

Envelopes should be fed from the multipurpose feeder. There is also an envelope tray available as an option. For more information, see “Optional accessories.”

WARNING: The printer uses heat in the printing process. Do not use material that may melt inside the printer, such as Tyvek® envelopes. Serious damage to the printer may result.

Printing on overhead transparency film

Use transparencies recommended for dry toner machines. Other transparencies may cause damage to the printer.

Appendix C: Adding memory to your printer

You can print more complex documents and download more fonts to your printer if you add RAM. To do this you have to open up the printer and insert a SIMM (Single Inline Memory Module). The printer can hold up to 64 MB of RAM, in two SIMM sockets. There is already at least one SIMM installed in the printer.

When you have installed the memory you must update the drivers in every Windows or Macintosh computer that uses the printer.

Specifications

You can add SIMMs of any size from 2 MB to 32 MB. SIMMs must be non-parity 72-pin, 70 nanoseconds or faster, non-composite, symmetrical, low-profile, 5-volt, and tin leaded. This kind of memory is readily available from many sources, or you can order upgrade kits direct from GCC. Use only EDO (extended data out) or FPM (fast page mode). You cannot use DIMMs, SDRAM, or other special RAM technologies.

SIMMs do not have to be installed in pairs, nor do you have to add a SIMM of the same size as that already installed. You can install any capacity SIMM in either socket.

Why would I need to add memory to the Elite 12ppm?

You can print virtually any 600 dpi pages with 8 MB of RAM and virtually any 1200 dpi pages with 16 MB (if your model of the Elite 12ppm supports this resolution).

You can use up RAM by setting the printer to Auto Switch between PostScript and PCL 5. Utilities like NEST, WebAdmin, and TCP/IP use small amounts of RAM; together with Auto Switch, these require under 4 MB.

In addition, you'll need printer RAM for any fonts you download. These require as much RAM as the space they occupy on the hard drive of your computer. In general, fonts occupy under 50K of RAM.

With an extra 8 MB of RAM or more, you'll see minor performance improvements.

Required tools and safety precautions

You should not need any tools to add memory to your printer. However, you should guard against static charges. Your body can easily accumulate a static charge; if you touch a sensitive piece of circuitry, you can destroy it without realizing.

GCC strongly recommends that you use a grounding wrist strap. You can buy one from the same place that you bought your SIMMs. If you do not have a grounding wrist strap, touch the perforated metal chassis of the printer (see step 9 following).

Installing the RAM into the Elite 12ppm

1. Switch off the printer. Do not unplug the power cord from the AC outlet.
2. Unplug the interface cables from the back of the printer.
3. If necessary, move the printer so that you have clear access to its left side.
4. Remove the paper tray.
5. Open the top cover by pressing the release button on the top right of the printer.
6. You need to remove the side cover. Unscrew the two thumbscrews at the rear of the printer (labelled "A" in the bottom picture). If these are tight, you may need to use a #2 Phillips screwdriver.
7. Reach inside the case. Pull the edge of the cover (B) toward you, then move the cover away from the rest of the printer to prevent it from latching again.
8. Place both hands on the top of the side cover (C). Lift the edge of the cover next to the top cover; this unlatches the cover, and you should be able to slide the cover away from the printer.

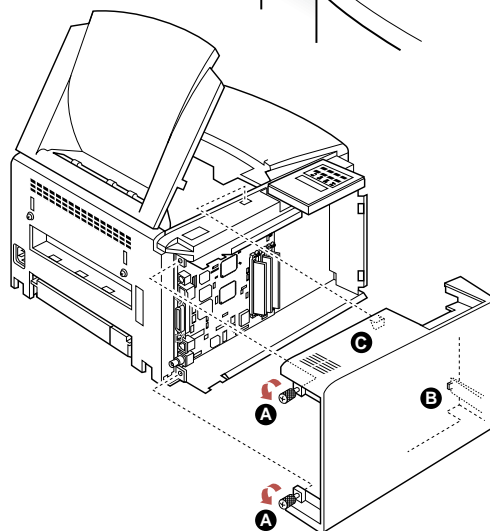
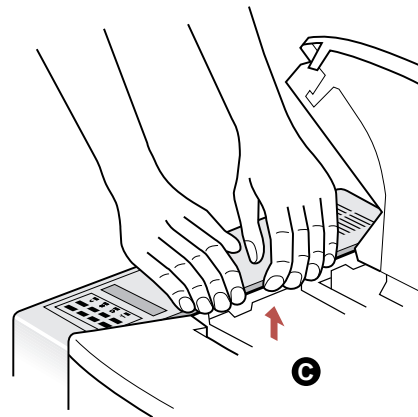
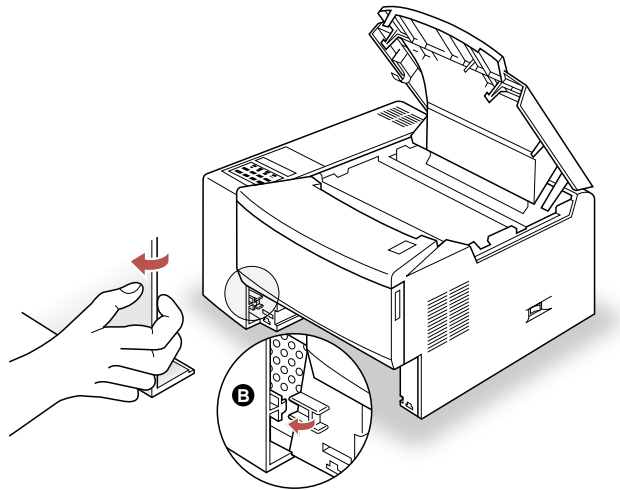

9. **IMPORTANT:** Attach a grounding wrist strap to the perforated metal chassis, or touch the chassis regularly to dissipate static electricity from your body.
10. The ROM and RAM cards are at the right of the controller board. Remove the ROM card to get better access to the RAM slots.

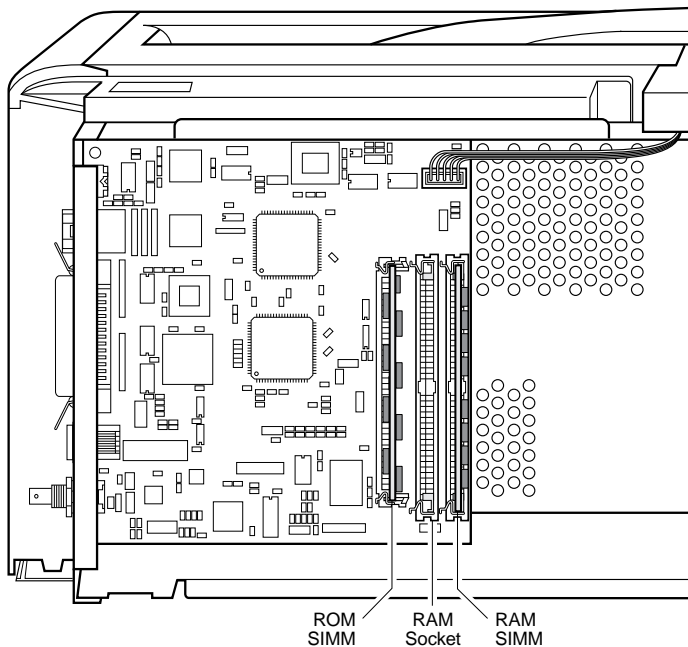

- a. Place your index fingers under the back edge of the ROM card.
- b. With your thumbs, slowly push the two retaining clips outward until the clips clear the top surface of the ROM card.
- c. Pivot the ROM card away from the retaining clips and remove the ROM card from the socket.

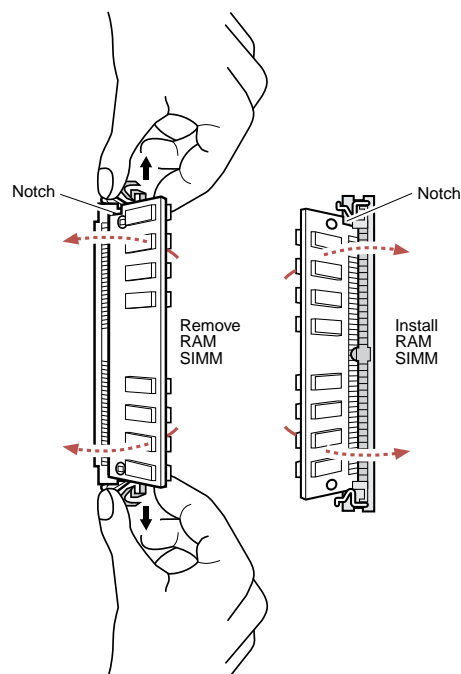

- d. The ROM card has a notch in it; this must be at the top of the contacts when you reinstall it.
- e. Put the ROM card in a safe place; after you have installed the RAM you will need to reinstall it.

11. Install the RAM SIMM.

- a. Position the SIMM so that the notch is toward the top.
- b. Place the SIMM in the socket so that the top of the SIMM is angled toward your left. Gently press the SIMM down into the socket.
- c. Pivot the SIMM so that it moves upright. The retaining clips will snap into place. If the retaining clips will not snap into place, you have not inserted the SIMM correctly.

12. Reinsert the ROM card in the same way that you inserted the SIMM.

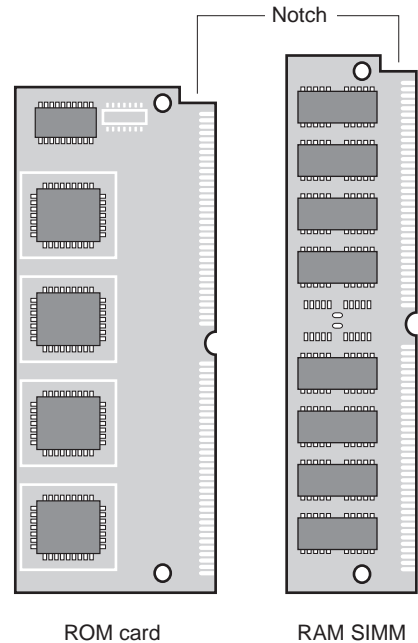

Warning: If the RAM SIMM and ROM card are not correctly inserted completely into the socket, your printer will display an error message when you turn it on and will not operate.

If you are having trouble inserting the SIMM or ROM card:

- Make sure that the cards are in the correct sockets. The ROM card is shorter than the SIMM.
 - Make sure that the notch in each card is toward the top.
13. Remove the grounding wrist strap from the printer (if necessary), and reinstall the printer's side cover. Don't tighten the thumbscrews. Turn on the printer and wait to see if the control panel shows the "ready" message. If it does, turn the printer off and go on to the next step.

If the ready message doesn't appear, turn off the printer and remove the cover. Gently try to rock the ROM card and SIMMs. If they are inserted correctly, they should not move. Carry out steps 11 and 12 again, and replace the cover and turn the printer on.

If the ready message still doesn't appear, and you are confident that you have installed the ROM card and SIMM correctly, call GCC technical support at 781-276-8620 (U.S. only) or your local GCC dealer or service center.

14. If the printer is ready, tighten the thumbscrews (at the rear of the side cover) by hand. Make certain that the printer is switched off. Reinstall the interface cables (if you are using the parallel port, insert the plug for this first).
15. Turn the printer on again. If the "ready" message appears on the control panel, the physical installation was successful. You now have to confirm the installation and update the printer driver on all computers that use this printer.

Confirming the installation

These steps confirm that printer recognizes the additional memory.

1. Switch on the printer.
2. Press the On Line button on the control panel; you'll see the message "Off Line" in the display panel.
3. Press the Menu key four times; you'll see "Printer Info" in the display panel.
4. Press the Enter key; you'll see the total amount of RAM that the printer recognizes. If this is the same as the new total of RAM, press the On Line key and the printer goes back on line.

If this figure is not the same as the total amount of RAM, turn the printer off, and remove the side cover. Now carry on from step 13 in the previous set of steps, beginning with the paragraph "If the ready message doesn't appear . . ."

Updating LaserWriter 8 printer driver

After you have installed extra memory you must update the LaserWriter 8 driver configuration on every Macintosh that uses the printer.

1. Switch the printer on.
2. Select the Chooser from the Apple () menu.
3. Click the LaserWriter 8 icon in the upper left area of the Chooser. You'll see the name of your Elite 12ppm in the upper right area of the Chooser below "Select a PostScript printer." If the name is not highlighted click on it to highlight it.
4. Click on the Setup button. You'll see the Setup dialog box.
5. Click on the Auto Setup button. You'll see a message box telling you that the computer is communicating with the printer.
6. After a few seconds you'll see the Setup dialog box again. Click the OK button to return to the Chooser, and then close the Chooser.

7. Repeat the preceding six steps on every Macintosh that will use the printer.

Updating Windows drivers (all versions)

After you have installed extra memory you must update the Windows printer driver on every Windows computer that will use the printer.

You need to carry out the next four steps once. This method works for all versions of Windows.

1. Switch the printer on.
2. Open a DOS Window. You can use the MS-DOS prompt icon on the Windows 95 (or NT 4.0) Start menu, or the MS-DOS Prompt icon in the Windows 3.1 (or NT 3.51) Main Window.
3. Assuming that your printer is on LPT1 and that Windows is installed on the C drive, type the following:

```
copy c:\windows\system\testps.txt lpt1
```

If your printer is connected to another port, or Windows is installed on a drive other than C, change the references. Do *not* use any Windows print commands; you must execute this command in DOS.

4. Type `EXIT` and press the Return key to return to Windows.

The printer will have printed a page which shows “Max Suggested VM (KB):” This is the maximum suggested Virtual Memory for the printer in kilobytes. You need to enter this figure in the Printers section of Windows Control Panel on every Windows computer that uses the printer. The way you do this varies between versions of Windows.

Windows 3.1

1. Open the Main Window in Program Manager, and double-click on the Control Panel icon.
2. Double-click on the Printers icon.
3. Click on the Setup button.
4. Click on the Advanced button.
5. Enter the suggested virtual memory value into the Virtual Memory (KB) box.
6. Click the OK button until you’ve returned to Program Manager.
7. Repeat the preceding six steps on every Windows 3.1 computer that will use the printer.

Windows 95

1. Choose Settings from the Start menu, and choose Printers from the submenu.
2. You'll see the Printers window; use the right mouse button to click on the Elite 12ppm icon.
3. You'll see a menu; choose Properties from this list.
4. You'll see the Properties tabbed dialog box; click on the Device Options tab.
5. At the top of the dialog box is a section marked Available printer memory (in KB). Enter the suggested virtual memory into this box.
6. Click OK.
7. Repeat the preceding six steps on every Windows 95 computer that will use the printer.

Windows NT 3.51

1. Open the Main Window in Program Manager, and double-click on the Control Panel icon.
2. Double-click on the Printers icon.
3. Click on the Setup button.
4. Click on the Advanced button.
5. Enter the suggested virtual memory value into the Virtual Memory (KB) box.
6. Click the OK button until you've returned to Program Manager.
7. Repeat the preceding six steps on every Windows NT 3.51 computer that will use the printer.

Windows NT 4.0

1. Choose Settings from the Start menu, and choose Printers from the submenu.
2. You'll see the Printers window; use the right mouse button to click on the Elite 12ppm icon.
3. You'll see a menu; choose Properties from this list.
4. You'll see the Properties tabbed dialog box; click on the Device Options tab.
5. In the window, click on Virtual Memory.
6. Enter the suggested virtual memory figure into the box.
7. Click OK.

8. Repeat the preceding seven steps on every Windows NT 4.0 computer that will use the printer.

Appendix D: Adding and configuring optional paper trays

This section provides information on installing and configuring optional Elite 12ppm paper trays. These include:

- A 500-sheet paper tray

You'll need to install the 500-sheet feeder to add the 500-sheet paper tray. You can load sheets of US Letter, A4, Legal 13" and Legal 14" paper. You can select this tray from your computer, using an application's Print dialog box.

The 500-sheet feeder is supplied with one 500-sheet paper tray.

- An envelope tray

You'll need to install the 500-sheet feeder to add the envelope tray. You can select this tray from your computer, using an application's Print dialog box.

- A face-up output tray

This fits on the rear of the printer to catch paper. You'll need this tray if you select the Rear (face up) option in an application's Print dialog box.

Because you can select the 500-sheet paper tray and the envelope tray from your computer, you'll need to change the printer driver software also. See the section "Updating your computer's software." You may want to make the 500-sheet paper tray your default paper tray. This is covered in the section of this appendix "Setting default paper trays through the control panel."

Installing the 500-sheet feeder and paper tray

If you carry out the installation by yourself, you'll need enough space to put the printer alongside the 500-sheet feeder. If you have someone to help you, that person can position the 500-sheet feeder while you hold the printer. When the installation is complete, the printer will be five inches higher. Make sure that there will be enough space above the printer to open the top cover.

1. Turn off the printer and disconnect the power and interface cables.
2. Remove the paper tray from the printer.

3. Unpack the 500-sheet feeder and remove all packing. Check that you have the sheet feeder, the 500-sheet paper tray, and four locking clips.
4. If you're working alone, place the sheet feeder next to the printer with the curved cover to the front. If you have help, one person should lift the printer up while the other puts the sheet feeder into place.

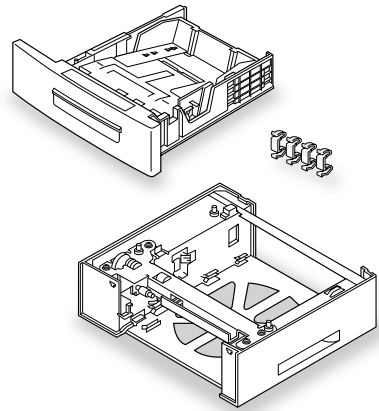

5. Lower the printer onto the sheet feeder. If you align the front right corner of each part, you'll find that the printer will locate on the three posts on the sheet feeder.

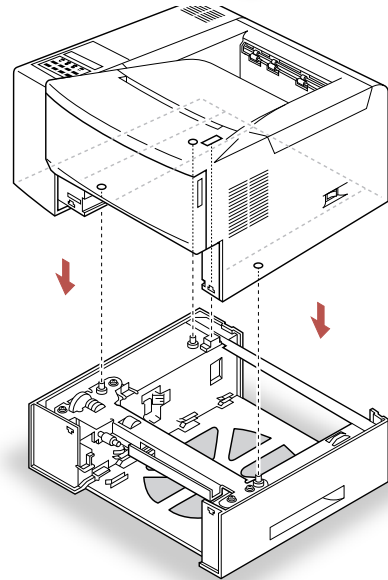

6. Fit the locking clips at the left and right front of both units.
7. Fit the locking clips at the left and right rear of both units.

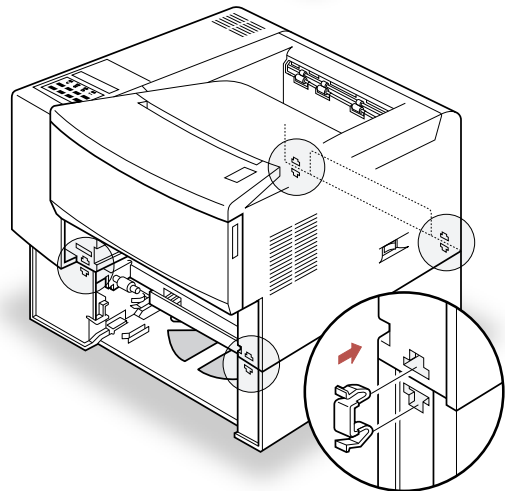

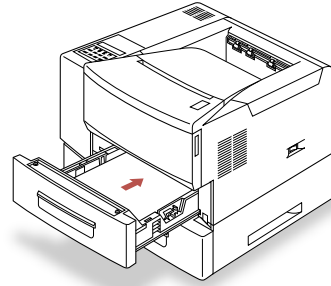
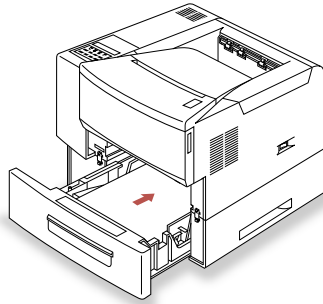

8. Replace the 500-sheet and the 250-sheet paper trays.
9. If necessary, move the printer to the location where it will be kept. There are two finger grips, one on either side of the sheet feeder.
10. Reconnect the power and interface cables.
11. Configure the software on each computer that will use the printer.

Using the 500-sheet paper tray and the envelope paper tray

The sheet feeder can hold either the 500-sheet paper tray or the envelope tray. These slide into the sheet feeder in the same way as the 250-sheet paper tray slides into the printer.

Loading the 500-sheet paper tray

Loading the 500-sheet paper tray is similar to loading the 250-sheet paper tray, but you adjust for different paper sizes in a different way.

1. Remove the paper tray from the feeder.
2. If you need to adjust the paper size guides, follow the next four steps. If not, go to step 6.
3. Turn the paper tray so that the front is away from you. The length guide has two indentations at left and right. Put your thumb in one and push up gently. When this releases that side, push up the other side.
4. Slide the guide forward or backward so that the colored tabs on the base of the paper tray align with the position for the paper size you'll be using.
5. Press down on the guide to lock it into place. Turn the paper tray around so that the front is toward you.
6. Squeeze the width guide lever toward its brace, and then pull the guide lever to the right.

7. Add paper to the tray by sliding it under the guides at the rear of the paper tray, and then pushing down on the paper at the front of the tray until it fits under the metal brackets. The paper tray may lock in the down position, but when you insert the paper tray into the feeder it will release.
8. Squeeze the width guide lever toward its brace, and then move it so that it lies next to the paper. Do not fit the width guide tightly against the paper, because this may cause paper jams.
9. Replace the paper tray into the feeder. You're now ready to print.

If you're printing on letterhead, place sheets so that the letterhead is face down and toward the front of the tray. If you use three-hole punched paper, position the paper so that the holes are on the left side of the tray.

Loading the envelope tray with envelopes

Note: The Elite 12ppm does not check the size of the envelopes you place in the tray. Make sure you're using the envelope size you specified in your application.

1. Remove the envelope tray from the feeder and turn it so that the handle is toward you.
2. If the postcard guide (a piece of plastic with the words "For Japanese Postcard") is at the rear of the area where you put envelopes, follow the next steps to remove it. Otherwise, go to step 9.
3. Place your forefingers under the tab at the front of the postcard guide, and press down on the top center of the guide with your thumb.

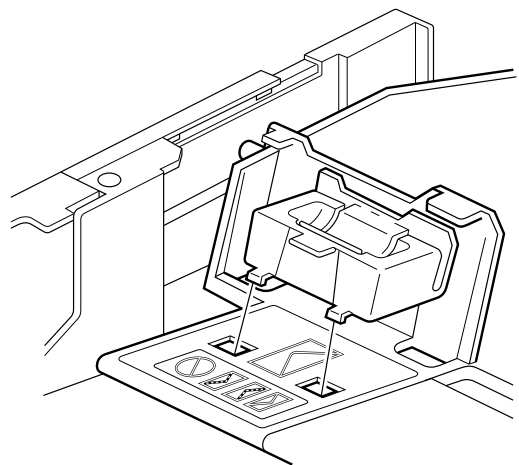
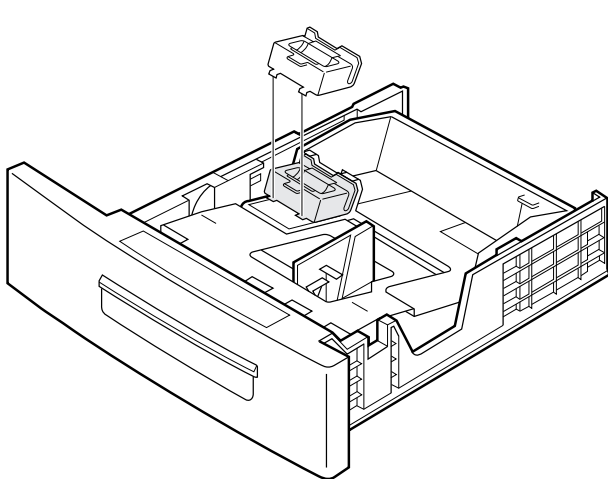

4. Roll the postcard guide toward you by pulling it forward. It will become free at the rear. Now you can slide it up and back to remove the two tabs from the slots and remove it from the envelope tray.
5. Move the postcard guide to the right rear of the envelope tray. This is where it's stored when you're not using it.
6. Tilt the back of the postcard guide up and toward you so that the two tabs fit in the two slots.
7. Place your forefingers under the tab at the front of the postcard guide, and press down on the top center of the guide with your thumb.
8. Rotate the postcard guide away from you so that it lies flat in the envelope tray. It will click into place.
9. If the guides are set to the envelope size you intend to use, go to step 11.
10. Lift the rear of the size guide and move it back or forward so that it fits the size of the envelopes you're using.

The holes in the size guide fit over a pair of tabs in the bottom of the envelope tray. The holes must fit over the tabs. The size guide has the names of envelope sizes by the holes.

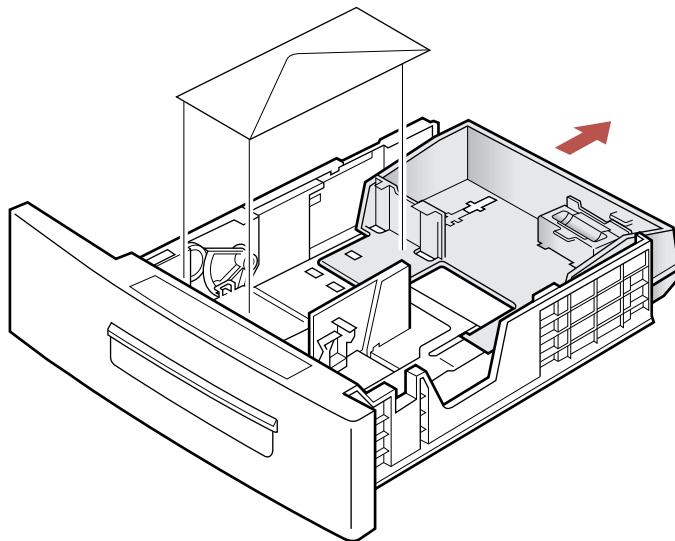

11. Squeeze the width guide lever toward its brace, and then pull the guide lever to the right.

12. Place the envelopes in the tray with the flaps upward and the hinge of the flap toward the right.
13. Squeeze the width guide lever toward its brace, and then move it so that it lies next to the envelopes. Do not fit the width guide tightly against the envelopes, because this may cause jams.
14. Replace the envelope tray into the feeder. You're now ready to print.

Loading the envelope tray with postcards

1. Remove the envelope tray from the feeder and turn it so that the handle is toward you.
2. If the postcard guide (a piece of plastic with the words "For Japanese Postcard") is *not* at the rear of the area where you put postcards, follow the next steps to install it. Otherwise, go to step 10.
3. The postcard guide is normally stored at the right rear of the envelope tray. Place your forefingers under the tab at the front of the postcard guide, and press down on the top center of the guide with your thumb.
4. Roll the postcard guide toward you by pulling it forward. It will become free at the rear. Now you can slide it up and back to remove the two tabs from the slots and remove it from the envelope tray.
5. Move the postcard guide to the back of the area where you load postcards and envelopes.
6. Tilt the back of the postcard guide up and toward you so that the two tabs fit in the two slots.
7. Place your forefingers under the tab at the front of the postcard guide, and press down on the top center of the guide with your thumb.
8. Rotate the postcard guide away from you so that it lies flat in the envelope tray. It will click into place.
9. If the guides are set to the postcard size you intend to use, go to step 11.
10. Lift the rear of the size guide and move it back or forward so that it fits the size of the postcards you're using.

The holes in the size guide fit over a pair of tabs in the bottom of the envelope tray. The holes must fit over the tabs. The size guide has the names of envelope sizes by the holes.

11. Squeeze the width guide lever toward its brace, and then pull the guide lever to the right.
12. Place the postcards in the tray with the side to be printed downward and the top of the postcard toward the right.
13. Squeeze the width guide lever toward its brace, and then move it so that it lies next to the postcards. Do not fit the width guide tightly against the postcards, because this may cause jams.
14. Replace the envelope tray into the feeder. You're now ready to print.

Installing the face-up output tray

The face-up output tray fits on the rear of the printer and holds output that would otherwise be deposited in the output tray on the top of the printer. If you have paper that's heavier than normal copy paper, you may need to use the face-up output tray to prevent paper jams and creasing.

If you use the multi-purpose feeder at the front of the printer, the face-up output tray gives you a straight-through path through the printer which minimizes jams and creasing.

1. Unpack the paper tray and remove all packing materials.

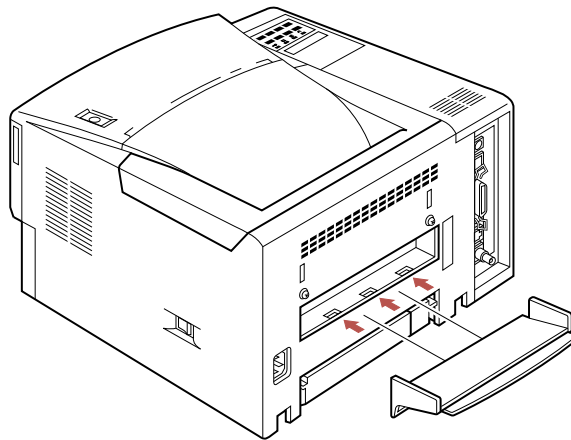

2. Align the tabs on the bottom of the tray with the holes in the back of the printer.
3. Push down on the tray to insert the tabs into the holes.
4. Slide out the underside of the tray to its fullest extent so that it locks into place.
5. Lift up the hinged part of the tray so that it extends further.

Setting default paper trays through the control panel

You may want to make the 500-sheet paper tray your default paper tray. This means that it will appear as the default choice in applications' Print dialog boxes.

You can make the 500-sheet tray the default by using the printer's control panel. Briefly, you take the printer offline, choose the Paper Handling menu and select Tray 1 from the Default Source submenu. Full details of how to change menu settings are in the section of this manual under "Control Panel."

You can change the settings in the control panel before you carry out the software updates on computers. If you decide to change the settings on the printer after you've updated the software on the computers, you'll have to update the software again.

Updating your computer's software

You have to update your printer driver so that the new paper tray will be shown as an option in the list of available paper trays. How you do this varies between operating systems. Abbreviated instructions are given below. Full instructions are included in the relevant sections of this CD-ROM. These changes must be made to every computer that will use the printer.

Macintosh

You make your Macintosh aware of changes to the printer by selecting the LaserWriter 8 icon in the Chooser, and clicking on the name of printer from the list. Then click Setup, and then click Auto Setup. The printer sends information to the computer, which updates the printer information in the computer.

Windows 3.1 and Windows NT 3.5 and NT 3.51

All versions of Windows before Windows 95 and NT 4.0 let you select any one of the complete range of standard and optional paper sources, even if you haven't installed those paper sources. If you choose a paper source that isn't installed, the printer uses the main paper tray. There's no need to configure your software, as the printer will now use the correct paper source when you select it.

Appendix E: QuickDraw GX

Introduction

QuickDraw GX is Apple Computer's printing and typographic system software. This appendix is a brief introduction to the printing features provided with QuickDraw GX and to the specific printing interface provided by GCC QuickDraw GX PostScript printer drivers.

Note: Additional information about QuickDraw GX printing can be obtained through Macintosh Guide, the online help system installed with System 7.5 or later. To access the information, click the question mark icon  on the right side of the menu bar and select Macintosh Guide. When the main Macintosh Guide dialog box appears, click *Printer & Fonts* from the Topics scroll box on the left.

Installing QuickDraw GX is a separate procedure included with System 7.5 or later. Please refer to your Apple System documentation for installation instructions.

Note: For the purposes of this appendix, the GCC SelectPress 1200 is used as an example to detail QuickDraw GX functions and features. Your GCC printer's supported paper sizes, paper sources, and features may differ.

QuickDraw GX compatibility

QuickDraw GX requires Macintosh System 7.5 or later. Your applications must support QuickDraw GX. There are three levels of QuickDraw GX compatibility:

- **Unadopted** – Applications that do not support QuickDraw GX will display Page Setup and Print dialog boxes that are variants of the standard QuickDraw GX dialog boxes. QuickDraw GX can be disabled in unadopted applications via the Turn Desktop printing On/Off option in the Apple Menu. Turning off desktop printing substitutes the LaserWriter 7.2 printer driver for the currently selected GCC QuickDraw GX printer driver.
- **Aware** – GX aware applications offer full support of QuickDraw GX Page Setup and Print dialog boxes, and Desktop printing.
- **Savvy** – GX savvy applications offer full support of QuickDraw GX Page Setup and Print dialog boxes, and Desktop printing. GX savvy applications also support the advanced typographic capabilities provided by QuickDraw GX. The guide does not cover QuickDraw GX typographic capabilities.

Installing GX drivers

The printing software for your new printer includes a QuickDraw GX printer driver. When you install the rest of your printing software, QuickDraw GX is also installed.

Choosing a GX printer driver (creating a desktop printer icon)

With QuickDraw GX you no longer use the Chooser to select a printer. Now, you use the Chooser to create desktop printer icons for each of your printers. These icons are then placed on your desktop. Once you have created the appropriate desktop printer icons, you will no longer need to open the Chooser for any printer related tasks.

A desktop printer contains general information about the capabilities of your printer (e.g., resolution(s), memory, supported paper sizes, etc.). Also, by creating a desktop printer the standard QuickDraw GX Page Setup and Print dialog boxes are edited to reflect the user-selectable options available with your particular printer.

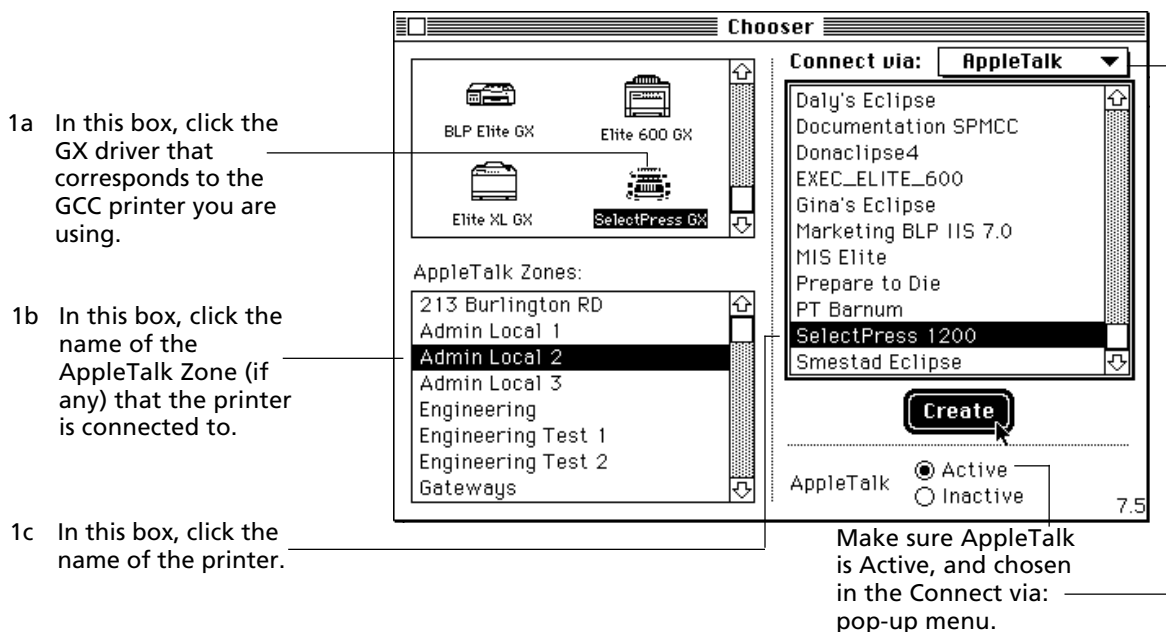

To create a desktop printer icon:

1. Choose the Chooser from the Apple () menu.

The Chooser appears.

2. Click Create.

In a few moments a desktop printer icon for the printer you selected will appear on your desktop.

Note: QuickDraw GX allows you to share a desktop printer, similar to the way you can share folders, with other users on the network. For more information open Macintosh Guide and refer to “share a printer with other users?” under the topic Printers and Fonts.

Configuring a desktop printer

After you have created a desktop printer you need to configure it. A desktop printer is configured through the desktop printer’s Printing menu. To access the Printing menu, click a desktop printer icon; the Printing menu will appear in the Macintosh menu bar next to the Special menu.

The Printing menu contains selections for the following functions:

Background printing

In QuickDraw GX, background printing is always on. The Printing menu contains the following options for controlling background printing:

- Start Print Queue
- Stop Print Queue
- Hold Print Request
- Resume on Page One
- Resume on Page...
- Set Print Time...

For information about the above commands and the background printing operation in general, open Macintosh Guide and click Look For. When the search window appears type background printing into the entry box and click Search. Double-click the manage printing jobs? phrase to access the information.

Setting default printer

If you have more than one desktop printer use this option to designate one of them as the default printer.

Note: Each time you create a new desktop printer, it becomes the default printer.

To set a default printer:

1. Click the desktop printer icon of the printer that you want to make the default.
2. Choose Set Default Printer from the Printing menu.

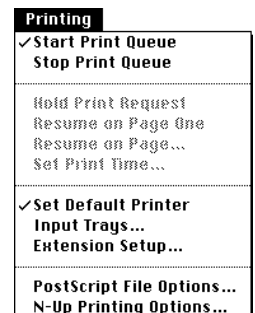

The default printer is now set. Notice that the default desktop printer icon now has a dark border around it. All print jobs will now be sent to this printer, unless you specify otherwise.



Determining input tray paper size(s)

The Input Trays... selection enables you to “tell” the printer driver about your printer’s paper sources and the paper sizes that they will contain.

When you first open the Input Trays... dialog box, it will look like the one pictured directly below. This dialog box will not display the paper sources available on your printer. However, if you click in the box containing unknown, you will see a list of the paper sizes that are supported by your printer.

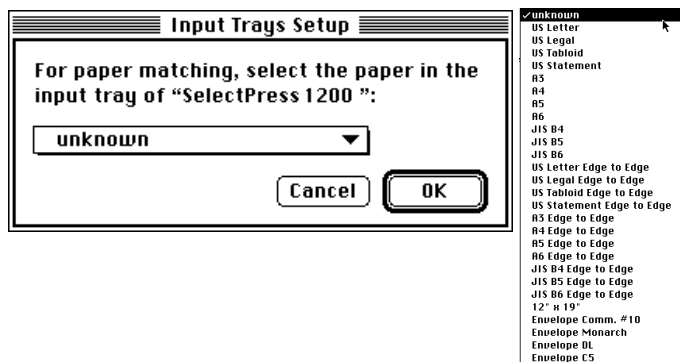

In order for the printer driver to learn about your printer’s paper sources (e.g., lower tray, upper tray multipurpose feeder, etc.) you must first print something. The quickest way to do this is:

1. Go to the Finder.
2. Choose Print Desktop... from the File menu.
3. In the Print dialog box, enter 1 in both the From and To boxes.
4. Click Print.

In a few moments a page will print.

5. Choose Input Tray... from the Printing menu again.

A new dialog appears, specific to your printer. It should display the paper sources available from your printer, and provide a paper size pop-up menu, listing all supported sizes, for each source.

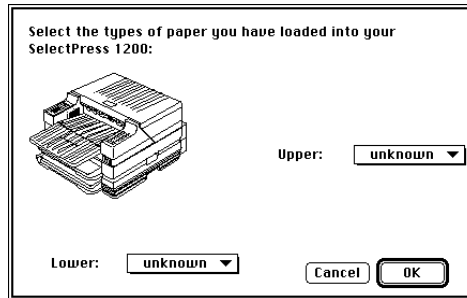

6. Choose a paper size for each paper source.

Although QuickDraw GX enables you to specify a paper size for each paper source, it is recommended that you leave the pop-up menus set to Unknown. This is recommended because the internal software of GCC printers is able to direct print jobs to the paper tray containing the correct size paper.

7. Click OK.

Selecting printer extensions

The QuickDraw GX software is “extensible,” meaning that Apple or third-party developers can add new capabilities (e.g., watermarks) to it. These extended capabilities are called printer extensions.

The Extension Setup... selection in the Printing menu enables you to choose which printer extensions to use with a desktop printer and the order in which they are to be applied during printing. Refer to the Macintosh Guide and the documentation accompanying third-party printer extensions for more information.

Configuring printer extensions

Some printer extensions can be configured from the Printing menu. These printing extensions will be added to the bottom of the Printing menu.

QuickDraw GX Page Setup dialog box (GX aware applications)

The QuickDraw GX Page Setup dialog box displayed by GX aware and savvy applications is a “two-level” dialog box. When you choose Page Setup from the File menu, the dialog box below appears:

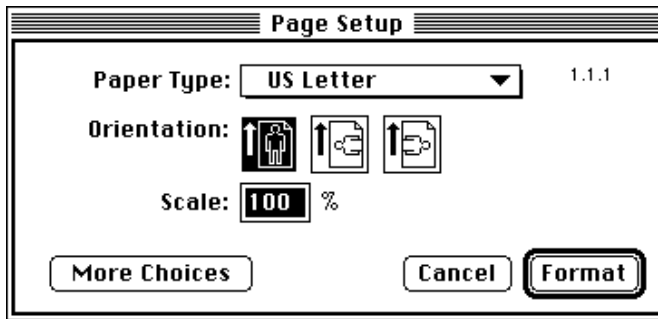

This is the first-level dialog box; it enables you to choose:

- Paper Type (paper size)
- Orientation
- Scaling

After choosing options, click:

More Choices to see the second-level of the Page Setup dialog box, which contains additional page setup options.

Cancel to close the Page Setup dialog without saving any changes.

Format to save your page setup selections and close the Page Setup dialog box.

If you click More Choices, the second-level of the Page Setup dialog box appears displaying additional page setup options.

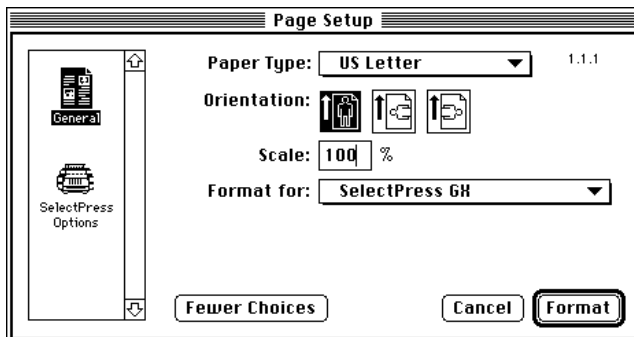

The second-level of the dialog box uses page setup panels to display different groups of options. Page setup panel icons appear in a scroll box on the left side of the Page Setup dialog box.

All printers have General panel, and all GCC printers have an Options panel.

The General page setup panel

When the General panel is highlighted, the Page Setup dialog box looks like the one pictured above. This panel contains the same options as the first-level Page Setup dialog, plus the Format for pop-up menu.



The Format for pop-up menu is divided into two sections by a dotted line:

Above the line is a list of all QuickDraw GX drivers installed in your Extensions folder.

Below the line is a list of desktop printers that you have created.

The default for this menu will correspond to the default desktop printer. However, if you want to print the document to another desktop printer, choose it from the list below the dotted line. This will enable you to access the Options panel for the newly selected printer.

Note: Choosing a new printer from the Format for menu does not change the default printer; use either the Set Default Printer command in the Printing menu in the Finder, or select a different printer in the Print to menu in the Print dialog box.

The Options panel

When Options (preceded by the name of your GCC printer) is highlighted in the scroll box on the left, the Page Setup dialog box looks like the one pictured below.

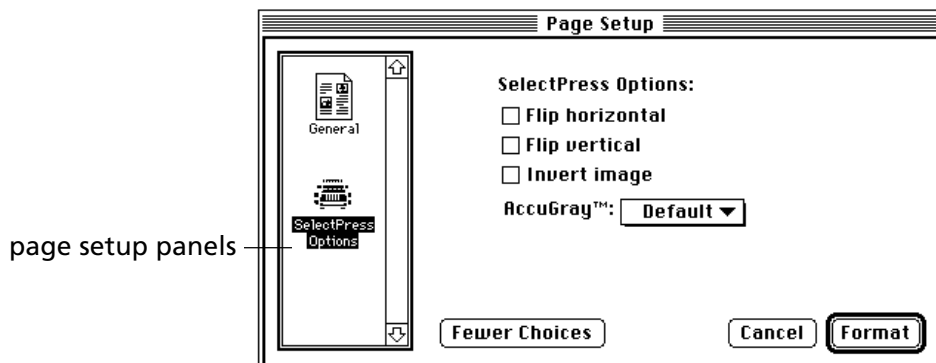

The first three options, Flip horizontal, Flip vertical, and Invert image, are available with all GCC printers. Other options may appear in this panel (e.g., AccuGray™) depending on the model of your GCC printer.

After choosing options, click:

Fewer Choices to return to the first level of the Page Setup dialog box.

Cancel to close the Page Setup dialog without saving any changes.

Format to save your page setup selections and close the Page Setup dialog box.

QuickDraw GX Print dialog box (GX aware applications)

The QuickDraw GX print dialog box displayed by GX aware and savvy applications is a “two-level” dialog box similar to the Page Setup dialog box.

When you choose Print from the File menu, the dialog box below appears:

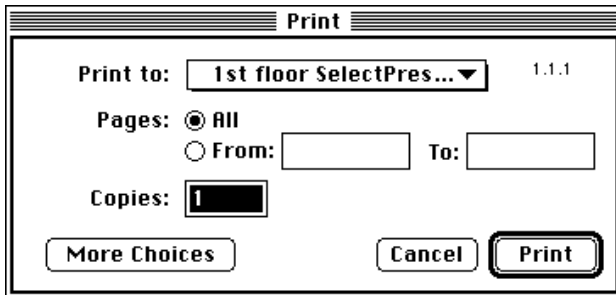

This is first-level Print dialog box; it enables you to choose:

- Printer (Print to)
- Page range (Pages)
- Number of copies (Copies)

The Print to pop-up menu enables you to print to a desktop printer other than the default desktop printer.

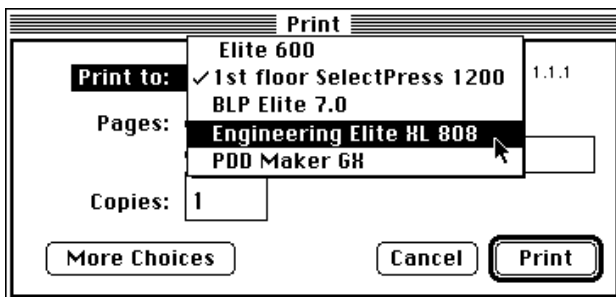

After choosing options, click:

More Choices to see the second level of the Print dialog box, which contains additional page setup options.

Cancel to close the Print dialog without saving any changes.

Print to print your document with the selected options.

If you click More Choices, the second-level of the Print dialog box appears displaying additional Print options.

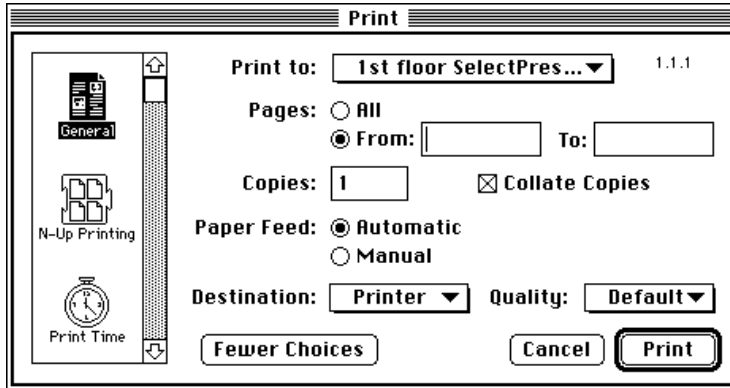

Like the Page Setup dialog box, the second-level of the Print dialog box uses page setup panels to display different groups of options. The panel icons appear in a scroll box on the left side of the Print dialog box.

All printers have a General panel. There are also a number of standard GX panels (Print Time and Paper Match). Third-party printer extension panels will also appear here.

The General print panel

When the General panel is highlighted, the Print dialog box looks like the one pictured above. This panel contains the same options as the first-level Print dialog box, plus the following additional options:

- Paper Feed
- Destination
- Quality

Paper Feed enables you to choose the paper source. The options are:

- Automatic. Choosing Automatic directs the printer to draw paper from the paper tray containing the paper size specified in the Page Setup dialog box's Paper Type pop-up menu. Automatic is the default.
- Manual. Choosing Manual directs the printer to prompt you to insert the specified paper size into the manual feed position and press the Manual Feed key.

Destination enables you to send your document to the selected desktop printer, or to save it to a PostScript file. Printer is the default.

If you choose PostScript®, the Print button changes to Save. Clicking the Save button causes a Save dialog box appear:

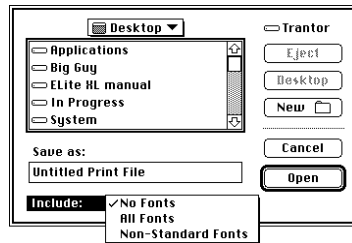

Enter a location that you want your file saved to.

You can also select the fonts that should be saved with your document, using the Include pop-up menu.

Note: Choosing the Non-Standard Fonts option includes all the fonts used in your document except for printer-resident fonts. (See your User's Manual for more information about resident fonts.)

Quality enables you to choose an output resolution (in dots-per-inch) for your document. The available resolutions will depend on the GCC printer model being used.

Other print panels

The Print dialog box also contains some other panels that are standard with QuickDraw GX.

Print Time – This panel enables you to control when a document will be printed.

Paper Match – This panel enables you to redirect a document to another paper tray. It also allows you to choose how the document should be adjusted (cropped, tiled, scaled) if the paper in the selected tray is too small.

After choosing options, click:

Fewer Choices to return to the first level of the Print dialog box.

Cancel to close the Print dialog without saving any changes.

Print to print your document with the selected options.

Page Setup and Print dialog boxes (unadopted applications)

If QuickDraw GX is enabled and you are printing from an application that has not adopted QuickDraw GX, the application will display alternate Page Setup and Print dialog boxes.

The dialog boxes will display standard page setup and print options (paper size, orientation, scaling, etc.), plus any printer-specific options (e.g., paper sizes, resolution) available with the selected desktop printer. Note: Not all printer-specific options will be available (e.g., AccuGray) from the alternate dialog boxes.

Note: The alternate dialog boxes may not be accessed the same way (i.e., choosing Page Setup and Print from the File menu) in all applications. For example, in PageMaker 5.0.x., the alternate Page Setup and Print dialog boxes are accessed by choosing Print from the File menu and then clicking Setup in the Print dialog box.

Page Setup dialog box

The Page Setup dialog box pictured below appears in applications that have not adopted QuickDraw GX.

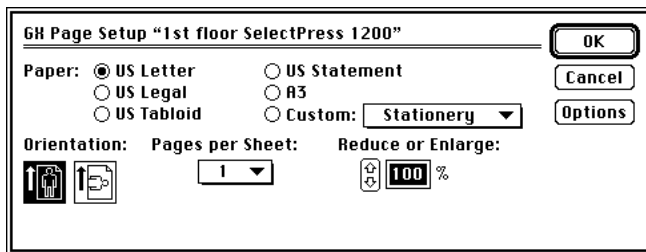

The Page Setup dialog enables you to choose:

- Paper (paper size)
- Orientation
- Reduce or Enlarge (scaling)
- Pages per Sheet (n-up printing)
- Options (Flip horizontal, Flip Vertical, Invert Image, and Precision Bitmap Alignment)

The Custom pop-up menu displays the additional paper sizes supported by the selected desktop printer.

Note: The default paper size for GCC GX drivers is US Letter. However, it has been observed that some applications will default to some other paper size.

Print dialog box

The Print dialog box pictured below appears in applications that have not adopted QuickDraw GX.

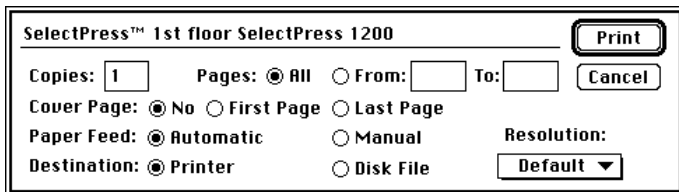

The Page Setup dialog enables you to choose:

- Number of copies (Copies)
- Page range (Pages)
- Cover Page
- Paper Feed
- Destination
- Resolution

The Resolution pop-up menu displays the resolutions supported by the selected desktop printer.

Turning off QuickDraw GX printing

If you are having problems printing from an application that has not adopted QuickDraw GX, you have the option of turning QuickDraw GX off.

The command Turn Desktop printing On/Off is inserted into the Apple Menu when an application that does not support QuickDraw GX is in use.

Note: The Turn Desktop printing On/Off command will only appear if QuickDraw GX Helper is installed.

When you choose Turn Desktop printing Off, QuickDraw GX substitutes LaserWriter 7.2 as the default printer driver. LaserWriter 7.2 is installed with System 7.5 and provides standard Apple LaserWriter paper source and paper size options. (See information on the following page.)

Substituting LaserWriter 7.1.2 or LaserWriter 8 for LaserWriter 7.2

The LaserWriter 7.2 printer driver provides paper sources and paper sizes that correspond to the standard Apple LaserWriter. Therefore, when this driver is used you will not be able to select the paper sizes and sources supported by your GCC printer.

However, you can regain access to your GCC printer's paper sizes and sources by causing QuickDraw GX to substitute either the customized LaserWriter 7.1.2 printer driver that comes with your GCC printer software, or LaserWriter 8 (which enables you to use the PPD file for your GCC printer).

Substituting Laser 7.1.2

You can force QuickDraw GX to use the custom version of Laser 7.1.2 by renaming it.

To rename the printer driver:

1. Open the Extensions folder.
2. Locate the printer driver that corresponds to your GCC printer's name.
3. Rename the printer driver.

Because of the method (alphabetical search) QuickDraw GX uses to substitute a driver, we recommend that you add either an A or a space to the beginning of the printer driver's name. For example the printer driver that comes with all Elite XL printers is named Elite XL. To force it to substitute for LaserWriter 7.2, change the name to AElite XL.

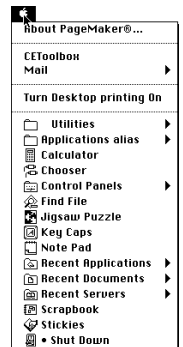

Substituting LaserWriter 8

The automatic substitution procedure used by QuickDraw GX always seeks to use a version of LaserWriter 7.x.x whenever possible. Therefore, you must first remove any versions of LaserWriter 7.x.x from the Extensions folder and then use the LaserWriter 8 Setup function to configure any printer(s) you plan to use, with the correct PPD(s).

Important Note: The following procedures presume a knowledge of System 7.5 and LaserWriter 8 components. For more information, refer to the LaserWriter 8 section of your printer's user's manual and/or the System 7 and 7.5 documentation. You may also contact GCC Technical Support at 781-276-8620.

To use LaserWriter 8:

1. Remove any versions of LaserWriter 7.x.x from the Extensions folder.

If you are not sure of the version of a printer driver, highlight it and select Get Info from the File menu. The version number will be displayed near the bottom of the box.

2. Determine if LaserWriter 8 is in your Extensions folder.

If you do not have a copy of LaserWriter 8 in the Extensions folder, install one using the installer on your printing software disk or your System disks.

3. Disable QuickDraw GX.

Use the Extensions Manager control panel to disable both QuickDraw GX and QuickDraw GX Helper.

4. Restart your Macintosh.

5. Open the Chooser.

6. Configure printer(s).

Use the Setup function to select a PPD for each GCC printer that you intend to use with QuickDraw GX desktop printing turned off.

7. Re-enable QuickDraw GX.

Use the Extensions Manager control panel to Re-enable both QuickDraw GX and QuickDraw GX Helper.

8. Restart your Macintosh.

9. Create desktop printer(s).

Now, when you choose Turn Desktop printing Off, LaserWriter 8 will be substituted instead of LaserWriter 7.2.

Important note on fonts: Because QuickDraw GX modifies your fonts when it is installed, documents printed with desktop printing turned off might not print correctly. If your document uses non-resident Type 1 fonts, they will print as bitmaps. To fix this problem, open the folder named •Archived Type 1 Fonts• in your System Folder. (This folder is created during the QuickDraw GX installation.) Copy the any Type 1 font files (you don't need to copy the font suitcases) that you need into the Fonts folder.

Appendix F: PCL

The table below shows some frequently-used PCL printer commands (escape sequences) that can be useful when sending a PCL print job from DOS to your GCC printer. PCL commands tell the printer which actions to perform or which fonts to use.

The commands listed below are a subset of the PCL command set. When entering escape sequences, substitute the # symbol in the escape sequence referenced in the left column with the appropriate number from the right column.

The character l shown in some examples after the ampersand (&) is a letter l (a lower-case letter L).

Printer command	Function	# refers to
E _C	Escape character	n/a
L _F	Line feed	n/a
F _F	Form feed	n/a
C _R	Carriage return	n/a
E _{CE}	Resets printer	n/a
E _{C&l#X}	Number of copies	1 to 32,767
E _{C&l0X}	Ejects page	n/a
E _{C&l#H}	Selects paper source	1 = tray 1, 2 = manual feed, 3 = manual feed, 4 = tray 2, 6 = MPFeeder
E _{C&l#A}	Selects a paper size	1 = executive, 2 = letter, 3 = legal 14", 26 = A4, 45 = JIS B5, 62 = legal 13", 71 = postcard, 80 = monarch, 81 = commercial 10, 90 = DL
E _{C&l#O}	Select orientation	0 = portrait, 1 = landscape
E _{C&a#L}	Sets left margin	Column number
E _{C&a#M}	Sets right margin	Column number
E _{C&l#E}	Sets top margin	Number of lines
E _{C&l#F}	Sets page length	Number of lines from top margin

The PCL font list page, which can be printed via your printer's control panel Info Pages menu, contains information about the 15 resident PCL fonts; a second page is printed if you have downloaded other PCL fonts to the printer's memory. The font list pages contain nine columns of information. See the following page for a description of the information in each column.

Elite™ 1212

PCL Resident Fonts

Num	Font Name	Symbol Set	Pitch	Points	Style	Weight	Print Sample
Resident Fonts — Bitmapped							
1	Courier 10 «Esc»(8U«Esc»(sOp10h12v0s0b3T	Roman-8	10	12	0	0	'ABCDEfghij } @ # ^ & = 123' AAEEÉËÿ°ÇçÑñ; ; z ÷ ÜßÀÐÒ
2	Courier 10 Bold «Esc»(8U«Esc»(sOp10h12v0s3b3T	Roman-8	10	12	0	3	'ABCDEfghij } @ # ^ & = 123' AAEEÉËÿ°ÇçÑñ; ; z ÷ ÜßÀÐÒ
3	Courier 10 obliq «Esc»(8U«Esc»(sOp10h12v1s0b3T	Roman-8	10	12	1	0	'ABCDEfghij } @ # ^ & = 123' AAEEÉËÿ°ÇçÑñ; ; z ÷ ÜßÀÐÒ
4	Courier 12 «Esc»(8U«Esc»(sOp12h10v0s0b3T	Roman-8	12	10	0	0	'ABCDEfghij } @ # ^ & = 123' AAEEÉËÿ°ÇçÑñ; ; z ÷ ÜßÀÐÒ
5	Courier 12 Bold «Esc»(8U«Esc»(sOp12h10v0s3b3T	Roman-8	12	10	0	3	'ABCDEfghij } @ # ^ & = 123' AAEEÉËÿ°ÇçÑñ; ; z ÷ ÜßÀÐÒ
6	Courier 12 obliq «Esc»(8U«Esc»(sOp12h10v1s0b3T	Roman-8	12	10	1	0	'ABCDEfghij } @ # ^ & = 123' AAEEÉËÿ°ÇçÑñ; ; z ÷ ÜßÀÐÒ
7	Line Printer 16 «Esc»(8U«Esc»(sOp16.67hb.5v0s0b0T	Roman-8	16.67	8.5	0	0	'ABCDEfghij } @ # ^ & = 123' AAEEÉËÿ°ÇçÑñ; ; z ÷ ÜßÀÐÒ
Resident Fonts — Scalable							
8	Dutch 801 «Esc»(8U«Esc»(s1ps1ze+v0s0b4101T				0	0	'abcDEfghijKLmnoPQu(\$)#&0123' AAEEÉËÿ°ÇçÑñ; ; z ÷ ÜßÀÐÒ
9	Dutch 801 Ital «Esc»(8U«Esc»(s1ps1ze+v1s0b4101T				1	0	'abcDEfghijKLmnoPQu(\$)#&0123' AAEEÉËÿ°ÇçÑñ; ; z ÷ ÜßÀÐÒ
10	Dutch 801 Bold «Esc»(8U«Esc»(s1ps1ze+v0s3b4101T				0	3	'abcDEfghijKLmnoPQu(\$)#&0123' AAEEÉËÿ°ÇçÑñ; ; z ÷ ÜßÀÐÒ
11	Dutch 801 Bd It «Esc»(8U«Esc»(s1ps1ze+v1s3b4101T				1	3	'abcDEfghijKLmnoPQu(\$)#&0123' AAEEÉËÿ°ÇçÑñ; ; z ÷ ÜßÀÐÒ
12	Swiss 742 «Esc»(8U«Esc»(s1ps1ze+v0s0b4148T				0	0	'abcDEfghijKLmnoPQu(\$)#&0123' AAEEÉËÿ°ÇçÑñ; ; z ÷ ÜßÀÐÒ
13	Swiss 742 Ital «Esc»(8U«Esc»(s1ps1ze+v1s0b4148T				1	0	'abcDEfghijKLmnoPQu(\$)#&0123' AAEEÉËÿ°ÇçÑñ; ; z ÷ ÜßÀÐÒ
14	Swiss 742 Bold «Esc»(8U«Esc»(s1ps1ze+v0s3b4148T				0	3	'abcDEfghijKLmnoPQu(\$)#&0123' AAEEÉËÿ°ÇçÑñ; ; z ÷ ÜßÀÐÒ
15	Swiss 742 Bd It «Esc»(8U«Esc»(s1ps1ze+v1s3b4148T				1	3	'abcDEfghijKLmnoPQu(\$)#&0123' AAEEÉËÿ°ÇçÑñ; ; z ÷ ÜßÀÐÒ

Elite™ 1212

PCL Downloaded Fonts

Num	ID	Font Name	Symbol Set	Pitch	Points	Style	Weight	Print Sample
Resident Fonts — Bitmapped								
1	204	Courier 10 «Esc»(8U«Esc»(sOp10h12v0s0b3T	Roman-8	10	12	0	0	'ABCDEfghij } @ # ^ & = 123' AAEEÉËÿ°ÇçÑñ; ; z ÷ ÜßÀÐÒ
2	205	Courier 10 Bold «Esc»(8U«Esc»(sOp10h12v0s3b3T	Roman-8	10	12	0	3	'ABCDEfghij } @ # ^ & = 123' AAEEÉËÿ°ÇçÑñ; ; z ÷ ÜßÀÐÒ

1. **Font Number:** The number you would use to select a font as the default font in the PCL Font Number submenu.
2. **Font Name:** The name of the default font. The escape sequence for the font is also shown below the font name.
3. **Symbol Set:** The specific group of special characters that will be available with the default font.
4. **Pitch:** The number of characters per inch.
5. **Points:** The vertical height of a character.
6. **Style:** Indicates the appearance and posture of the typeface, such as italic, upright, or condensed.
7. **Weight:** Indicates the density of a typeface, such as medium, bold, light, or black.
8. **Print Sample:** Shows a sample of how the font will print.
9. **Font ID:** The identification number assigned to a downloaded font.

Appendix G: Interface connector pinouts

Use the following pinouts and descriptions of the various printer interface connectors if you need to purchase or make a new cable.

RS-422 Serial:

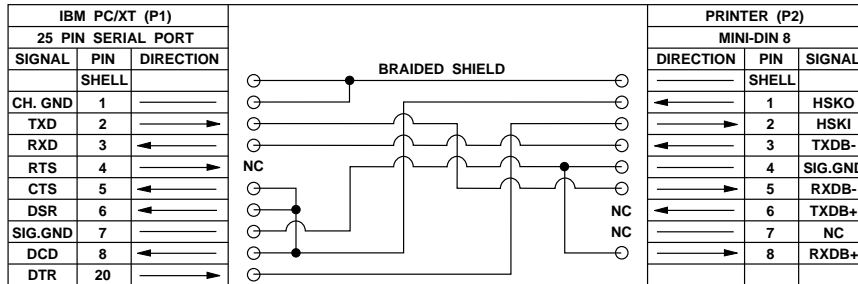

Uni-directional Parallel

PIN	SIGNAL	DESCRIPTION	DIRECTION
1	/STROBE	Data Strobe	In to Printer
2	D1	Data Bit 1	In
3	D2	Data Bit 2	In
4	D3	Data Bit 3	In
5	D4	Data Bit 4	In
6	D5	Data Bit 5	In
7	D6	Data Bit 6	In
8	D7	Data Bit 7	In
9	D8	Data Bit 8	In
10	/ACK	Acknowledge	Out from Printer
11	BUSY	Busy	Out
12	PERROR	Paper Empty	Out
13	SELECT	Select Out	Out
14	/AUTOFD	Not Used	In
15	NC	Not Used	
16	GND	Signal Ground	

17	CGND	Chassis Ground	
18	NC	Not Used	
19-30	GND	Signal Ground	
31	/INIT	Initialize	In
32	/FAULT	Printer Fault	Out
33	NC	Not Used	
34	NC	Not Used	
35	NC	Not Used	
36	/SELECTIN	Not Used	

Bi-directional Parallel (nibble mode)

PIN	SIGNAL	DESCRIPTION	DIRECTION
1	/STROBE	Data Strobe	In to Printer
2	D1	Data Bit 1	In
3	D2	Data Bit 2	In
4	D3	Data Bit 3	In
5	D4	Data Bit 4	In
6	D5	Data Bit 5	In
7	D6	Data Bit 6	In
8	D7	Data Bit 7	In
9	D8	Data Bit 8	In
10	/ACK	Acknowledge	Out from Printer
11	BUSY	Busy	Out
12	PERROR	Paper Empty	Out
13	SELECT	Select Out	Out
14	/AUTOFD	Autofeed	In
15	NC	Not Used	
16	GND	Signal Ground	
17	CGND	Chassis Ground	
18	NC	Not Used	
19-30	GND	Signal Ground	

31	/INIT	Initialize	In
32	/FAULT	Printer Fault	Out
33	NC	Not Used	
34	NC	Not Used	
35	NC	Not Used	
36	/SELECTIN	Select In	In

Ethernet (UTP):

PIN	SIGNAL	DESCRIPTION	DIRECTION
1	TX+	Transmit+	Out
2	TX-	Transmit-	Out
3	RX+	Receive+	In
4	NC		
5	NC		
6	RX-	Receive-	In
7	NC		
8	NC		

LocalTalk:

PIN	SIGNAL	DESCRIPTION	DIRECTION
1	HSKO	Handshake Out	Out
2	HSKI	Handshake In	In
3	TXD-	Transmit Data-	Out
4	SIG GND	Signal Ground	
5	RXD-	Receive Data-	In
6	TXD+	Transmit Data+	Out
7	NC	Not Used	
8	RXD+	Receive Data+	In

Appendix H: Radio and TV interference

Your printer generates radio frequency energy and, if not installed and used in accordance with GCC Technologies' instructions, it may cause interference to radio and television communications.

This GCC printer was certified under test conditions that included the use of shielded cables and connectors between system components. It is mandatory that you use shielded cables and connectors to reduce the possibility of causing interference to radio, television, and other electronic devices.

You can determine whether your printer is causing interference by turning it off. If the interference stops, it was probably caused by your printer.

If your printer does cause interference to radio or television reception, you can try to correct the interference by using one or more of the following measures:

- Turn the television or radio antenna until the interference stops.
- Move the printer to one side or the other of the television or radio.
- Move the printer farther away from the television or radio.
- Plug the printer into a different outlet so the printer and receiver are on different circuits.

If necessary, you should consult your dealer or a radio/television technician for additional suggestions. You may also find helpful the following booklet prepared by the Federal Communications Commission: *How to Identify and Resolve Radio-TV Interference Problems*. This booklet is available from the US Government Printing Office, Washington, DC 20402, Stock No. 004-000-00345-4.

Appendix I: Elite 12ppm Consumables and optional accessories

Optional items

You can add optional accessories to your Elite 12ppm. Contact GCC Direct Sales at (800) 422-7777 (U.S. only) or your local dealer. For a complete list of optional Elite 12ppm items, see our World Wide Web store at www.gccdirect.com.

Elite 12ppm Lower Sheet Feeder

If you want to add a 500-sheet paper tray or an envelope feeder, you must first install the lower sheet feeder. This attaches to the bottom of the Elite 12ppm; the trays fit inside it. The lower sheet feeder is supplied with a 500 sheet paper tray. This holds up to 500 sheets of letter, A4, Legal 13" and Legal 14" paper. You can attach a single lower sheet feeder to the Elite 12ppm printer.

Elite 12ppm Optional paper trays

The following optional paper trays are available for use with the Elite 12ppm:

- **Universal paper tray**

Capacity 250 sheets — Replacement for the standard tray shipped with the Elite 12ppm. You may find it convenient to have separate paper trays for each kind of stationery you use.

- **Envelope tray**

Commercial #10, Monarch, DL, C5, Postcard — Optional tray with a capacity of 30 standard weight envelopes. Requires the 500-sheet feeder.

- **500-sheet paper tray**

Capacity 500 sheets — requires the 500-sheet feeder.

Elite 12ppm Face Up output tray

The Elite 12ppm face up output tray attaches to the rear of the printer. It holds output when you choose Rear Output (Face Up) in your applications. When you use it with the multipurpose feeder, it provides a straight through paper path.

Elite 12ppm Accessory Order Numbers

Each Elite 12ppm accessory description is followed by the GCC order number.

- Elite 12ppm Toner cartridge AC16120
- Elite 12ppm Standard Universal paper tray (250 sheet capacity) AC16128
- Elite 12ppm Lower Sheet Feeder (500 sheet capacity)
including a 500-sheet paper tray AC16126
(compatible paper trays) – AC16130, AC16132
- Elite 12ppm Paper tray (500 sheet capacity) AC16130
(use with sheet feeder) – AC16126
- Elite 12ppm Envelope Tray (30 envelope capacity) AC16132
(use with sheet feeder) – AC16126
- Elite 12ppm Face up output tray AC16136
- Elite 12ppm 8 Megabyte memory expansion kit AC16311
- Elite 12ppm 16 Megabyte memory expansion kit AC16313
- Elite 12ppm 32 Megabyte memory expansion kit AC16315
- Farallon PhoneNET Connector Kit AC13270
- HDI 30 to SCSI cable AC13369
- SCSI terminator AC10060
- Uni-directional Parallel Cable AC15282
- Shipping box and foam 102.16349
- Elite 12 ppm CD-ROM with software and documentation 101.16317
- Quick Installation guide 030.16319

Appendix J: Glossary

5 percent page: A page of text, used to provide a standard for the number of pages that can be printed using one toner cartridge. So named because the toner covers five percent of the page.

Adobe Type 1: One of the two common file formats for fonts (the other is *TrueType*). Requires a PostScript printer or *Adobe Type Manager* for fonts to print correctly. Fonts can be scaled to any size.

Adobe Type Manager: A program which allows you to use Adobe Type 1 format fonts on a non-PostScript printer. Also improves the on-screen display of fonts.

AppleTalk: A network communication protocol for connecting Apple computers and other devices to share information. When used with an EtherNet network interface, this is known as EtherTalk.

Apply button: A button, usually found in a dialog box, which makes any changes specified in the dialog box. Unlike the OK button it does not close the dialog box. See OK button, Close button, and Cancel button.

AccuGray: A GCC software technology that enables truer halftone reproduction by counteracting the effects of dot gain and by adjusting the print engine's gray level response to a 1 to 1 correspondence.

all ports active: Technology that allows you to connect several computers and/or networks to one printer. Each port is able to accept print jobs without affecting the others.

application (program): A program, such as Microsoft Word or PageMaker, used to manipulate information.

baud: The speed at which data is transferred (bits/second).

bit: The smallest unit of computer information (a single binary digit).

bitmap: A representation of a shape in computer memory. It's achieved by dealing with the image area as a series of very small squares; if any square is more than 50 percent covered by the image, that square is black (or, in color bitmaps, a color). Bitmaps typically are made out of areas 1/72 or 1/96 of an inch square. Bitmap images cannot easily be enlarged or reduced.

bitmap font: A font whose characters consist of the arrangement of bits into shapes. These characters are used as screen fonts on computers that do not use scalable fonts, and they tend to be jagged when printed on a high-resolution printer. Now largely replaced by *outline fonts*.

black and white: Used to define images which have no color information. Strictly speaking, it should only describe images with no shades of gray - just areas of black. See *halftone*.

bus network: A form of network cabling where each computer is connected (*daisy-chained*) to the computer at either side of it. The ends of the bus are terminated.

byte: A unit of computer information equal to 8 bits.

Cancel button: A button, usually found in a dialog box, which closes the dialog box and does not carry out any changes that may have been specified. See *Apply button*, *Close button*, and *OK button*.

check box: A small square section of a dialog box that when clicked puts a check mark in the box. This shows that the feature or choice mentioned in the accompanying caption has been selected. Clicking again removes the check mark. Check boxes can usually be selected and deselected independently. See *Option button*.

Chooser: A Macintosh accessory that allows you to select and use networked devices such as printers and file servers.

client/server: A form of networking used in larger installations. One or more computers are dedicated as *servers* and handle all the network traffic from the other computers, known as *clients*. Printers are usually installed anywhere on the network and are controlled by the server(s). See also *peer-to-peer*.

clone: A functionally equivalent piece of hardware or software.

Close button: A button, usually found in a dialog box, which closes the dialog box so you can see behind it. The Close button usually does not cause any changes to occur. See *Apply button*, *Cancel button*, and *OK button*.

complex page: A page consisting of graphics or text and graphics. Complex pages may require more printer RAM to print.

Control Panel: Part of the Windows or Macintosh system software. Also the panel at the front of the printer itself.

daisy-chain: A way of connecting devices on a network. Cables pass from one device to the next. The ends of the daisy chain are not connected, but have *terminators* attached.

default: A value or setting built in to a system or program. A default can usually be changed, but is chosen to be satisfactory to the majority of users.

default printer: The printer that will appear as the default choice in print dialog boxes in applications.

desktop: The working environment of the Macintosh Finder and Windows systems that displays folders, files, and applications as icons.

device: A piece of equipment, such as a hard disk, printer, or scanner, used with a computer. Also known as a *peripheral*.

dialog box: A small window that opens up on the screen to get user input or acknowledgment.

disk space: The amount of space available on a hard disk or floppy disk.

dot gain: An unavoidable increase in the size of halftone dots due to the interaction of toner, paper, heat, and pressure during the printing process. This increase in dot size increases the density of toner on paper, causing the printed output to appear darker. GCC's AccuGray technology works to counteract the effects of dot gain.

dots per inch (dpi): A measurement of resolution, or the density of dots, for a given output device. Higher dots per inch usually give better image quality.

download: To send a font to a printer's built-in memory (RAM) or hard disk.

drop-down list: A section of a dialog box that contains one entry but has a downward-pointing arrow at the right. Clicking on the arrow reveals a list of alternative choices.

engine: The entire printer apart from the electronics.

EtherNet: A commonly-used network protocol.

flow control: The control of information along an interface to enable the interface to take only as much information as it can handle.

folder: An organization tool for arranging documents, applications, and other folders on a storage device. Known as a *directory* on Windows systems prior to Windows 95.

font: A collection of letters, numbers, punctuation marks, and special characters with a consistent design. Also known as a typeface.

fuse: To melt toner particles so that they adhere to the paper.

fuser unit: The part of the printer that melts toner particles.

grayscale: The range of gray tones between black and white. The human eye can distinguish up to approximately 256 levels of gray.

halftone: An image made up of black toner dots. The printer simulates darker or lighter shades of gray by printing greater or lesser amounts of dots in each area of the image. This is a common method of printing photographs.

halftone cell: A pattern of printed dots; each dot can be turned on or off in order to represent different percentages of gray.

high-quality fonts: Outline fonts that are shipped with the printer or purchased from your dealer. On the Macintosh, screen fonts are used to create your documents and the printer replaces them with high-quality fonts during the printing process. See *outline fonts*.

Installer: An application that installs the software.

interface: The point at which two devices are physically connected, enabling them to communicate. Printers have a number of sockets; you plug a connector into these sockets depending on whether you're communicating with the printer by network, parallel, or serial port.

jaggies: A slang term for the effect when some fonts and images print with jagged (rather than smooth) edges. This usually happens if you attempt to print a resized bitmapped image or font, or if you have screen fonts but not printer fonts on the Macintosh.

lpi: (lines per inch) A measure of the frequency of a halftone screen (usually between 53 and 200). Lpi refers to the lines of halftone spots that make up the screen. Higher lpi usually means a better-quality image.

LocalTalk cable system: Apple's network cable system used to support an AppleTalk network system.

megabyte: A unit of measurement equal to 1024 kilobytes, or 1,048,576 bytes.

NEST (Novell Embedded Systems Technology): A feature of many GCC printers, which can be used on Novell networks. Normally, a Novell network requires you to dedicate a computer as a *print server*; NEST allows the printer itself to fill that function.

NetWare: Network software from Novell that enables computers to communicate with other computers and peripherals such as printers.

network: A group of computers and peripheral devices, such as printers, that are interconnected so they can communicate with each other. A network also includes the hardware, such as cables that connect the devices, and the software that allows them to communicate.

OK button: A button, often found in a dialog box, which closes the dialog box and makes any changes that were specified. See *Cancel button*, *Close button*, and *Apply button*.

on-screen preview: A representation of a *vector image* as a screen bitmap. This allows you to edit the image in graphics programs; your changes are also applied to the vector image. Windows previews are BMP format; Macintoshes are PICT. If you transfer a vector image from Mac to PC or vice versa, you'll usually lose the on-screen preview.

option button: A circular section of a dialog box when clicked causes the center part of the circle to turn black. This indicates the feature or choice mentioned in the accompanying caption has been selected. Option buttons are used in groups, and selecting one button deselects all the others. See also *Check box*.

outline fonts: Fonts whose characters are *vector images*, built using mathematical representations. Unlike bitmapped fonts, they can be scaled to any size without degradation. Examples include PostScript (Adobe Type 1) and TrueType fonts.

output tray: Where paper is received after it has been printed. Usually on the top of the printer.

pages per minute (ppm): The maximum number of pages that the printer's paper transport is designed to pass through in one minute. If your pages are largely text, your printer will produce printed pages close to the rated ppm; if you have more complex graphics images, pages will appear more slowly.

paper jam: What happens when paper doesn't flow smoothly through the paper path. Paper is usually trapped inside the printer and creased or torn.

paper tray: Removable storage for sheets of paper. The printer takes sheets of paper from the tray during the printing process. Also known as a *cassette*.

parallel: A way of transmitting information using (typically) eight bits at the same time. Most PCs have a parallel port to connect to a printer. See also *serial*.

parity: A bit (number) in serial communication that is used to detect bad data transmission.

PCL: A page description language, similar to but much less powerful than PostScript. Requires PCL-format fonts. Invented by Hewlett-Packard, PCL is now uncommon.

peer-to-peer: A form of networking used mainly in smaller installations. Any computer can communicate directly with any other computer. Printers are often attached to computers directly. See also *client/server*.

peripheral device: Any device used to input, output, or exchange data. See *device*.

pixel: The smallest area of a computer screen that can be controlled by software programs. Screen *resolution* is measured in either the number of pixels visible across the entire screen (for example, 640 x 480), or in pixels per inch. Screen resolution is usually less than printer resolution, so you can't guarantee that what you see is exactly what will print.

platform: A type of computer standard (Windows, Mac OS, DOS, etc.) which covers all computers that conform to that standard, including *clones*.

port: A communication connection often located on the back of computers and peripheral devices, usually in the form of a socket.

PostScript: A high-level page description language. PostScript commands describe the text and graphic images in a document.

PostScript printer: A printer equipped with circuitry that changes PostScript information into a bitmapped image for printing.

print server: A computer on a network that takes print jobs from other computers and sends them to the printer. This means that other computers on the network can return to processing almost immediately while the print server communicates with the printer. See also *NEST*.

printer description files: Files that allow certain applications to use printer-specific features.

printer driver: The software that creates a page description when you want to print a document. This description is sent to the printer for printing.

printer font: The high-quality part of fonts for the Macintosh.

printer memory or printer RAM: Temporary storage space used to hold downloaded fonts and for calculations during print jobs. If there's insufficient printer memory, you may not be able to print at the highest resolution of the printer.

printing software: Computer software needed for printing that includes the printer driver and other related files.

printer's disk: A hard disk attached to the printer that contains fonts and also serves as temporary storage during print jobs.

processor: The CPU (central processing unit) or "chip" of the printer, which control all its actions.

properties: Configuration characteristics of a peripheral or of a software feature. Usually found in Windows operating systems or applications.

protocol: All the characteristics of (usually) a communications system, such as a network. A protocol describes how the messages are constructed in software, as well as the types of connectors used.

rasterize: To convert an image into a dot pattern that can be represented by dots of toner on a page.

resolution: The number of dots per unit of length or area. Higher resolution usually leads to better image quality. High resolution pages typically have sharper text and more detailed photographs than low resolution pages. High resolution pages may require more RAM to print than the amount supplied in the printer.

RAM (Random-Access Memory): Temporary storage area for information. This information is lost every time the computer or printer is shut down.

ROM (Read-only Memory): Permanent storage area for information. This information is usually supplied by the manufacturer of the computer or printer and is not accessible by the user.

RS-422: An 8-pin hardware interface that allows the transfer of data in an asynchronous *serial* format. It has five user-defined parameters: baud rate, data bits, stop bits, parity, and flow control. Your GCC printer's RS-422 interface is shared with the LocalTalk interface.

screen fonts: Fonts displayed on the Macintosh screen; they're represented on paper with *printer fonts*. Screen fonts are not as high quality as printer fonts; if you don't install the printer fonts the printer will print the screen fonts.

screen frequency: The number of lines of dots per unit of length in a halftone screen.

SCSI: A standard for transmitting data. While often used to connect devices to computers (particularly Macintoshes), it is used by GCC printers to optionally connect hard drives to store fonts and other information. It is *not* used to connect the printer to the computer. The SCSI chain on a printer is totally independent of any SCSI chain on the computer.

serial: A way of transmitting information one bit at a time. Serial transmission of data to the printer is usually slower than *parallel* printing.

sheet feeder: An additional paper source. It requires a paper tray to actually hold the paper.

simple page: A page purely consisting of text.

star network: A form of networking where each computer is connected to a hub, and all network traffic flows through the hub.

stop bits: The number of bits that specify the end of a serial transmission frame.

straight through paper path: A way of passing paper through the printer without it bending. Sometimes heavy or easily damaged paper can only be printed this way. Usually set up by using the multipurpose feeder and a rear output tray.

smoothing: A process that makes the text and graphics of some applications look better.

startup disk: The disk (usually a hard disk) containing the System and Finder files used to run the Macintosh.

System 7, OS 8: Various versions of the Macintosh system software (“Mac OS”).

system administrator: The person responsible for keeping a network running smoothly. This person may be needed to configure computers and printers connected to a network.

System Folder: The folder containing Macintosh System and Finder files used to start and run the Macintosh.

terminator: A small device connected at the ends of certain network and SCSI cabling. If you don’t use a terminator where needed, the network or SCSI chain will operate erratically or may not operate at all.

toner: A special plastic powder in the toner cartridge that “fuses” to the paper to create an image.

toner cartridge: A plastic box containing toner; the cartridge is placed in the printer to supply toner during the printing process. Toner cartridges often also contain an imaging drum.

TrueType: A file format for fonts which can be scaled to any size. Supporting software is built in to Windows and Macintosh system software. One of the two major font file formats (the other is *Adobe Type 1*).

vector images: Images that are described in computer memory using a series of instructions on how to draw each part. Because there’s no reference to the quality of the printer or other output device, vector images can be easily scaled up or down. Eventually the instructions are converted to a bitmap image (or *rasterized*) in the printer when the image is printed. PostScript or EPS format files are an example of vector images.

WebAdmin: GCC’s program for remotely configuring printers on a network using a web browser. Printers can be configured from anywhere in the world using the World Wide Web.

Windows: A name for a series of Microsoft operating systems. Windows 3.0 and 3.1 do not have built-in networking; Windows for Workgroups, Windows 95, and Windows NT 3.51 and 4.0 can be networked without additional software.

wizard: A series of dialog boxes used in Windows systems to carry out complicated tasks step-by-step. Often used to configure items like printers.

x: (as in “Windows 3.x”, or “System 7.x”) A character representing any number or numbers. Therefore, “System 7.x” refers to variations of the Macintosh system software including 7.1 and 7.5.5, and all other variations beginning with “System 7.”

Appendix K: Warranties and Licenses

Software License Agreement

OPENING THE BAG CONTAINING THE SOFTWARE (the "Software") WHICH ACCOMPANIES THIS MANUAL INDICATES YOUR ACCEPTANCE OF THE TERMS AND CONDITIONS CONTAINED IN THIS LICENSE AGREEMENT. THE TERMS OF THIS LICENSE AGREEMENT APPLY TO YOU AS THE ORIGINAL LICENSEE OF THE SOFTWARE AND THE RELATED USER DOCUMENTATION (the "Documentation") AND TO ANY SUBSEQUENT LICENSEE THEREOF.

IF YOU DO NOT ACCEPT OR AGREE TO THE TERMS OF THIS LICENSE AGREEMENT YOU MAY RETURN THE PRODUCT, WITH DATED PROOF-OF-PURCHASE OF THE PRODUCT, TO YOUR DEALER WITHIN 10 DAYS FOR A FULL REFUND OF PURCHASE PRICE THEREOF. ALL RETURNED SOFTWARE MUST BE UNUSED AND IN THE UNOPENED PLASTIC BAG.

LICENSE

In return for payment of the purchase price of your GCC Technologies Product ("the Product"), you have been granted a limited, non-exclusive license ("License") to use the Software and the Documentation on the terms set forth in this License Agreement.

GCC Technologies, Inc. ("GCC") retains ownership of these copies of the Software and the Documentation. These copies of the Software and the Documentation are licensed to you according to the following terms:

PERMITTED USES

YOU MAY:

1. Use the Software with any appropriate GCC product.
2. Copy the Software onto a single hard disk drive.
3. Transfer the Software to another party, if the other party agrees to the terms and conditions of this License Agreement and completes and returns a Registration Card to GCC. The Registration Card may be obtained by writing to GCC's Customer Service department at the address set forth below. If you transfer the Software to any other party, you must transfer all copies and the Documentation to such party.
4. Make a single copy of the Software on another diskette for backup purposes only.

PROHIBITED USES

THE LICENSE OF THE SOFTWARE AND THE DOCUMENTATION GRANTED TO YOU IS LIMITED, AND YOU MAY NOT:

1. Make copies of any of the Documentation or make copies of the Software other than as expressly set forth above.

2. Alter, modify or adapt the Software or the Documentation, including translating, decompiling, disassembling, creating derivative works, or merging the Software with other software.
3. Use any backup diskette you have made or allow someone else to use any backup diskette unless the Software on the original diskette is defective.
4. Rent, sublicense, assign or otherwise transfer any interest in any of the Software or the Documentation except as set forth above.
5. Modify or erase any copyright, trademark or proprietary rights notice on any medium containing the Software or the Documentation or copy or reproduce any of the Software or the Documentation without all of GCC's copyright, trademark and proprietary rights notices.

The License is effective until terminated. You may terminate it at any time by destroying all copies of the Software you have and mailing your original Software diskettes and the Documentation to GCC. The License and your right to use the Software will automatically terminate upon your failure to comply with any provision of this License Agreement or upon GCC's election to terminate the License as set forth below. You agree upon such termination to destroy all copies of the Software which you have and to mail your original Software diskettes and the Documentation to GCC.

GCC retains all rights and title to the Software and the Documentation except for the limited license contained herein. The Software and the Documentation are protected by the copyright laws of the United States. There are severe penalties, civil and criminal, for copyright infringement. Nothing in this License Agreement constitutes a waiver of GCC's rights under the copyright laws of the United States or any other law.

Limited Software Warranty

WARRANTY

If you discover physical defects in the medium on which the Software or the Documentation are distributed, at its option, GCC will either replace the medium at no charge to you or terminate the License and require the return of your Product, and upon such return, refund to you the purchase price thereof. To qualify for this warranty, you must return the defective medium with proof-of-purchase to GCC during the one year period after you acquired the Software.

Except as set forth in the immediately preceding paragraph, GCC PROVIDES THE SOFTWARE AND THE DOCUMENTATION "AS IS" AND WITHOUT WARRANTY OF ANY KIND, EITHER EXPRESS OR IMPLIED, INCLUDING, BUT NOT LIMITED TO, ANY IMPLIED WARRANTIES OF MERCHANTABILITY OR FITNESS FOR A PARTICULAR PURPOSE OR WARRANTIES OF QUALITY OR PERFORMANCE. YOU THE LICENSEE ARE ASSUMING THE ENTIRE RISK AS TO THE QUALITY OF THE SOFTWARE AND THE DOCUMENTATION AND THE RESULTS OF ITS USE. Your exclusive remedy with respect to the Software, the Documentation and this License Agreement, shall be limited to the replacement of any defective medium, or refund of the purchase price of your Product, as set forth above.

APPLE COMPUTER, INC. MAKES NO WARRANTIES, EITHER EXPRESS OR IMPLIED, REGARDING THE ENCLOSED COMPUTER SOFTWARE PACKAGE, ITS MERCHANTABILITY OR ITS FITNESS FOR ANY PARTICULAR PURPOSE. THE EXCLUSION OF IMPLIED WARRANTIES IS NOT PERMITTED BY SOME STATES. THE ABOVE EXCLUSION MAY NOT APPLY TO YOU. THIS WARRANTY PROVIDES YOU WITH SPECIFIC LEGAL RIGHTS. THERE MAY BE OTHER RIGHTS THAT YOU HAVE WHICH VARY FROM STATE TO STATE.

IN NO EVENT WILL GCC BE LIABLE FOR DIRECT, INDIRECT, SPECIAL, INCIDENTAL, OR CONSEQUENTIAL DAMAGES ARISING OUT OF THE USE OR INABILITY TO USE THE SOFTWARE OR DOCUMENTATION, even if advised of the possibility of such damages. In particular, GCC shall have no liability for any programs or data stored or used with the Software, including the costs of recovering such programs or data. In no event shall GCC's liability with respect to the Software, the Documentation and this License Agreement, in contract, tort (including negligence) or otherwise, exceed the original price paid by you for your Product.

THE WARRANTY AND REMEDIES SET FORTH ABOVE ARE EXCLUSIVE AND IN LIEU OF ALL OTHERS, ORAL OR WRITTEN, EXPRESS OR IMPLIED. No GCC dealer, agent, or employee is authorized to make any modification or addition to this warranty.

SOME STATES DO NOT ALLOW THE EXCLUSION OF IMPLIED WARRANTIES OR LIABILITY FOR INCIDENTAL OR CONSEQUENTIAL DAMAGES, SO THE ABOVE LIMITATION OR EXCLUSION MAY NOT APPLY TO YOU. THIS WARRANTY GIVES YOU SPECIFIC LEGAL RIGHTS, AND YOU MAY ALSO HAVE OTHER RIGHTS WHICH VARY FROM STATE TO STATE.

GENERAL

This License Agreement is governed by the laws of the Commonwealth of Massachusetts. This License Agreement constitutes the entire agreement between GCC and you concerning the Software and the Documentation, and supersedes all prior communications, agreements and understandings, written or oral, between GCC and you with respect thereto.

Should you have any questions concerning this License Agreement, the Software or the Documentation, you may contact GCC by writing to Customer Service, GCC Technologies Inc., 209 Burlington Road, Bedford, MA 01730-9143. For the name of the nearest GCC service center or representative, call (800) 422-7777.

TRADEMARKS

GCC Technologies and the GCC Technologies logo are registered trademarks of GCC Technologies Inc. Elite 12ppm is a trademark of GCC Technologies, Inc. Apple, AppleTalk, LocalTalk, LaserWriter, EtherTalk, Macintosh, and the Apple logo are registered trademarks of Apple Computer, Inc. Finder and TrueType are trademarks of Apple Computer, Inc. PostScript is a registered trademark of Adobe Systems Incorporated. Adobe and Illustrator are registered trademarks of Adobe Systems Incorporated. Adobe Type Manager, ATM, and Separator are trademarks of Adobe Systems Incorporated. PageMaker is a registered trademark of Adobe Systems Incorporated. MacPaint and MacWrite are registered trademarks of Claris Corp. LetraSet is a registered trademark of Essetle Pendaflax Corp. DesignStudio is a trademark of Essetle Pendaflax Corp. IBM is a registered trademark of International Business Machines Corp. Helvetica, Palatino, and Times are registered trademarks of Linotype-Hell AG Corp. Phoenix Technologies, PhoenixPage, and Multi-grey are registered trademarks of Phoenix Technologies. Centronics is a registered trademark of Centronics Data Computer Corp. Ethernet is a registered trademark of Xerox Corp. Microsoft and Word are registered trademarks of Microsoft Corp. Windows and Windows 95 are trademarks of Microsoft Corp. Bitstream is a registered trademark of Bitstream Inc. Speedo, Bitstream Dutch, Bitstream Swiss, Bitstream Swiss Narrow, and Bitstream Zapf Calligraphic are trademarks of Bitstream Inc. ITC Avant Garde, ITC Bookman, ITC Zapf Chancery, and ITC Zapf Dingbats are registered trademarks of International Typeface Corporation. New Century Schoolbook is a registered trademark of Kingsley-ATF Type Corp. Helvetica, Palatino, and Times are registered trademarks of Linotype-Hell AG Corporation. Tyvek is a registered trademark of Dupont Chemical Corp. PhoneNET is a registered trademark of Farallon Corp. Cheapernet is a registered trademark of National Semiconductor. CHAMP is a trademark of Amp Inc. Canvas is a trademark of Deneba Systems. Quark and QuarkXpress are trademarks of Quark Inc. Ready,Set,Go is a registered trademark of Manhattan Graphics Corp. PCL is a registered trademark of Hewlett-Packard Company. NetWare is a registered trademark of Novell Corp. Other trademarks are the property of their respective owners.

K-2

Limited Hardware Warranty

GCC Technologies, Inc. ("GCC") warrants, for the limited period of one year from the date of original purchase, the Elite 12ppm sold by GCC and any accompanying media on which GCC software is recorded (the "Product") to be free from defects in materials and workmanship. During the warranty period, GCC or its authorized representative will, at its option, repair, replace or refund the purchase price of any defective product at no additional cost, provided you return it during the warranty period, transportation charges prepaid, to GCC or an authorized GCC dealer or representative. You must attach your name, address and telephone number, a description of the problem, and a dated proof-of-purchase bearing the serial number for each product returned for warranty service.

This Warranty is limited to the original purchaser of the product and is not transferable unless otherwise agreed by GCC in writing. This Warranty does not apply to any product which has been damaged by accident, abuse, or misuse, which has been modified without the prior written permission of GCC.

GCC MAKES NO WARRANTY OR REPRESENTATION, EITHER EXPRESS OR IMPLIED, WITH RESPECT TO THE SOFTWARE SUPPLIED WITH THE PRODUCT, ITS QUALITY, PERFORMANCE, MERCHANTABILITY, OR FITNESS FOR A PARTICULAR PURPOSE. AS A RESULT, THE SOFTWARE IS LICENSED "AS IS," AND YOU THE LICENSEE ASSUME THE ENTIRE RISK AS TO ITS QUALITY AND PERFORMANCE.

EXCEPT AS EXPRESSLY SET FORTH ABOVE, GCC MAKES NO OTHER WARRANTIES WITH RESPECT TO THE PRODUCT, EXPRESS OR IMPLIED, INCLUDING BUT NOT LIMITED TO, ANY IMPLIED WARRANTIES OF MERCHANTABILITY OR FITNESS FOR A PARTICULAR PURPOSE.

UNDER NO CIRCUMSTANCES SHALL GCC'S LIABILITY ARISING OUT OF OR IN CONNECTION WITH THE PRODUCT OR THE USE OF, OR THE INABILITY TO USE, THE PRODUCT, IN CONTRACT, IN TORT (INCLUDING NEGLIGENCE), OR OTHERWISE EXCEED THE PURCHASE PRICE OF THE PRODUCT, AND IN NO EVENT SHALL GCC BE LIABLE FOR SPECIAL, INCIDENTAL OR CONSEQUENTIAL DAMAGES INCLUDING, BUT NOT LIMITED TO, DAMAGES FOR DOWNTIME OR LOST PROFITS, BUSINESS, USE OF SOFTWARE OR EQUIPMENT, OR GOODWILL, WHETHER OR NOT GCC HAS BEEN ADVISED OF THE POSSIBILITY OF SUCH DAMAGES.

Some states do not allow the exclusion or limitation of implied warranties or liability for incidental or consequential damages, or do not allow limitations on how long an implied warranty lasts, so the above limitations or exclusions may not apply to you. ANY IMPLIED WARRANTIES, INCLUDING ANY IMPLIED WARRANTIES OF MERCHANTABILITY OR FITNESS FOR A PARTICULAR PURPOSE, ARE LIMITED IN DURATION TO ONE YEAR FROM THE DATE OF ORIGINAL PURCHASE OF THIS PRODUCT. This warranty gives you specific legal rights, and you may also have other rights which vary from state to state.

No GCC dealer, representative, agent or employee is authorized to make any modification, extension or addition to this warranty on behalf on GCC. THE WARRANTIES AND REMEDIES SET FORTH ABOVE ARE EXCLUSIVE AND IN LIEU OF ALL OTHERS, EXPRESS OR IMPLIED.

For the name of the nearest GCC service facility or representative, call GCC at (800) 841-1833, or write to: Director of Customer Service, GCC Technologies Inc., 209 Burlington Road, Bedford, MA 01730-9143.

FEDERAL COMMUNICATIONS COMMISSION

WARNING: This equipment was tested and found to comply with the limits for a Class A digital device, pursuant to Part 15 of the FCC Rules. These limits are designed to provide reasonable protection against harmful interference in a residential installation. This equipment generates, uses, and can radiate radio frequency energy and, if not installed and used in accordance with the instructions in this manual, may cause harmful interference to radio communications. However, there is no guarantee that interference will not occur in a particular installation. For more information about radio frequency interference, refer to the section of this manual on Radio and TV interference.

CANADIAN REGULATIONS

This equipment is a Class A digital apparatus that complies with the Radio Interference Regulations, CRC c. 1374.

IMPORTANT: Changes or modifications to this product not authorized by GCC Technologies Inc. could void the FCC Certification and negate your authority to operate the product. This product was tested for FCC Compliance under conditions that included the use of shielded cables and connectors between system components. It is important that you use shielded cables and connectors to reduce the possibility of causing interference to radios, television sets, and other electronic devices. You can obtain the proper shielded cables from GCC Technologies or from an Authorized GCC Technologies dealer.

CLASS 1 LASER PRODUCT

LASER SAFETY: This printer is certified as a Class 1 laser product under the U.S. Department of Health and Human Services (DHHS) Radiation Performance Standard according to the Radiation Control for Health and Safety Act of 1968. This means that the printer does not emit hazardous radiation. Since radiation emitted inside the printer is completely confined within protective housings and external covers, the laser beam cannot escape from the machine during any phase of user operation. The Center for Devices and Radiological Health (CDRH) of the U.S. Food and Drug Administration implemented regulations for laser products on August 1, 1976. These regulations apply to laser products marketed in the United States. The label on the printer indicates compliance with the CDRH regulations and must be attached to the laser products marketed in the United States.

Caution - Use of controls, adjustments, or performance of procedures other than those specified in this manual may result in hazardous radiation exposure.

EPA ENERGY STAR COMPUTERS AWARD

The Elite 12ppm printer is designed to conserve electricity. With its power-saving design, the Elite 12ppm qualifies for the U.S. Environmental Protection Energy Star Computers Award.



CREDITS

© Copyright GCC Technologies Inc., 1998. All rights reserved.

The Elite 12ppm User Manual was written by David Field.

It was edited by Saadia Baloch, Lee Doron, Armik Ghazarians, Brian Harriss, Krista Ingram, Bill Krech, Rebecca Leebow, Michael McCabe, and David Nicholson.

Cover design and illustrations by Bill Krech.

Fonts used were Frutiger and Minion. Printed in USA; part number 030.16403 rev B.

DECLARATION OF CONFORMITY

Information and Authorized Signature

TEST SAMPLE: Elite 1212 Laser Printer

RESPONSIBLE PARTY: GCC Technologies, Inc.

209 Burlington Road

Bedford, MA 01730

TELEPHONE NUMBER: 781-275-5800

AUTHORIZED SIGNATURE: _____

AUTHORIZED SIGNATORY: _____

Mr. Armik Ghazarians

MEASUREMENT PROCEDURE: ANSI C63.4-1992

TEST SPECIFICATION: FCC RULES AND REGULATIONS, DoC

RETLIF TESTING LABORATORIES TEST REPORT NO. R-3095N

ACCREDITATION - NAVLAP (ISO/IEC) GUIDE 25:

October 1997

SIGNATURE OF RESPONSIBLE TEST ENGINEER: _____

J. MONAHAN

TEST PERSONNEL: M. McSweeney

TESTING DATE: June 2, 1997

REPORT DATE: June 17, 1997

Description of the Measurement Facility is on file at Retlif Testing Laboratories, Goffstown, NH



Retlif Testing Laboratories

REPORT No. R-3095N

DECLARATION OF CONFORMITY

according to ISO/IEC Guide 22 and EN45014

Manufacturer's Name: GCC Technologies

Manufacturer's Address: 209 Burlington Road
Bedford, MA 01730-9143

declares that the product:

Product Name: Elite 12ppm

Model Name: Elite 1212 (1200dpi)

Product Options: 500 sheet feeder	AC16126
250 sheet Universal paper cassette	AC16128
500 sheet Universal paper cassette	AC16130
Duplex Unit	AC16134
Face Up Output Tray	AC16136
Envelope cassette (30 envelope capacity)	AC16132

conforms to the following Product Specifications:

Safety: EN60950 (1992) / UL 1950 (1993) / CSA 22.2 No. 950 (1993)

EMC: EN55022 (1988) / CISPR 22 (1993), Class B (1)
EN50082-1 (1992) Generic Immunity
IEC 801-2 (1991) Electrostatic Discharge
IEC 801-3 (1984) Radiated RF Immunity
IEC 801-4 (1988) Electrical Fast Transient/Burst

Supplementary Information: The product herewith complies with the requirements of the Low Voltage Directive 73/23/EEC and EMC Directive 89/336/EEC. and carries the CE marking accordingly.

(1) The product was tested with an IBM PS/2 computer system and the Macintosh Quadra computer system.

GCC Technologies:

United States-	209 Burlington Road, Bedford, MA 01730-9143, U.S.A., Tel: (781) 275-5800, Fax: (781) 275-1115
United Kingdom-	729 London Road, Hounslow, Middlesex, England TW3 1SE, Tel: (44) 181-754-6000, Fax: (44) 181-754-6060
Germany-	Hahnbuschweg 2-4, D-24147 Klausdorf, Germany, Tel: (49) 431 79 97 610, Fax: +49 (0) 431 79 97 666
France-	104 Rue Castagnary F-75015, Paris, France, Tel: (33) 1 45 33 51 51, Fax: +33 (0) 1 45 33 33 51

For information on ordering consumable items and accessories for the Elite 12ppm, please call GCC Sales at (800) 422-7777 (U.S. and Canada only). Outside the U.S. and Canada, call your local GCC dealer.

CONSUMABLE ITEMS AND ACCESSORIES



Toner cartridge (single)	AC16120
500 sheet feeder (compatible paper tray)	AC16126 AC16130
250 sheet Universal paper cassette	AC16128
500 sheet Universal paper cassette (use with sheet feeder)	AC16130 AC16126
Face Up Output Tray	AC16136
Envelope cassette (30 envelope capacity) (use with sheet feeder)	AC16132 AC16126
8 megabyte memory expansion kit	AC16311
16 megabyte memory expansion kit	AC16313
32 megabyte memory expansion kit	AC16315



GCC Technologies, Inc.
209 Burlington Road
Bedford, Massachusetts 01730-9143
781-275-5800
<http://www.gcctech.com>

Free Manuals Download Website

<http://myh66.com>

<http://usermanuals.us>

<http://www.somanuals.com>

<http://www.4manuals.cc>

<http://www.manual-lib.com>

<http://www.404manual.com>

<http://www.luxmanual.com>

<http://aubethermostatmanual.com>

Golf course search by state

<http://golfingnear.com>

Email search by domain

<http://emailbydomain.com>

Auto manuals search

<http://auto.somanuals.com>

TV manuals search

<http://tv.somanuals.com>