

JTP28BF/CF/WF

GE® 30" Built-In Double Oven

Dimensions and Installation Information (in inches)

KW Rating	
240V	8.8
208V	6.6
Breaker Size	
240V	40 Amps
208V	30 Amps

Cabinet	30"
A - Overlap of Oven Over Side Edges of Cutout	11/16"-3/4"
B - Overlap of Oven at Bottom of Cutout	1"
Oven	
C - Overall Depth	23-1/2"
D - Overall Height	52-7/8"
E - Overall Width	29-3/4"

Note: Cabinets installed adjacent to wall ovens must have an adhesion spec of at least a 194°F temperature rating. **Electric wall ovens are not approved for installation with a plug and receptacle. They must be hard wired in accordance with installation instructions. Suitable oven cabinet bracing must support 275 lbs.**

Installation Information: Before installing, consult installation instructions packed with product for current dimensional data.

For answers to your Monogram®, GE Profile™ or GE® appliance questions, visit our website at ge.com or call GE Answer Center® service, 800.626.2000.

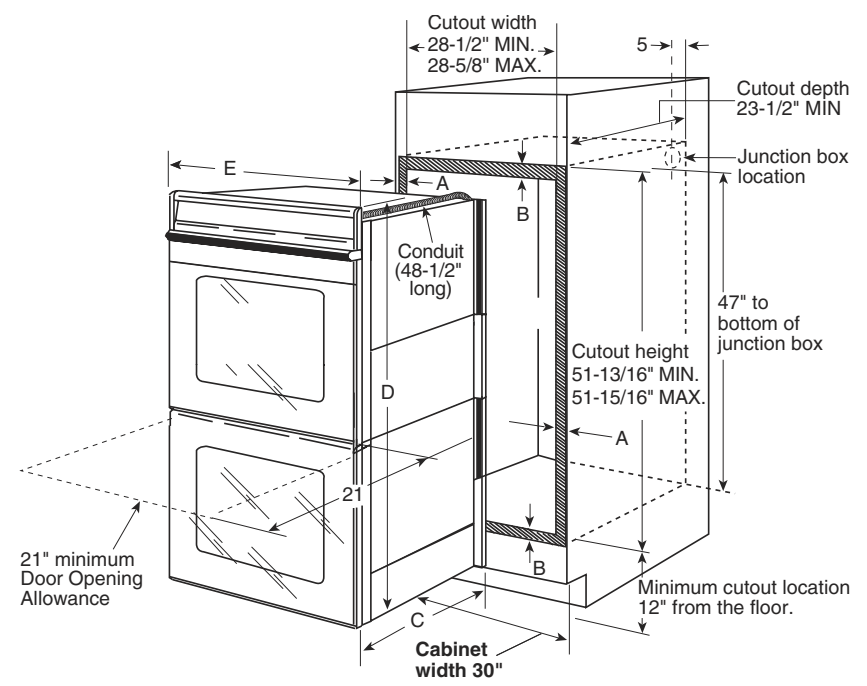

MOST 30" WALL CABINETS CAN BE USED WITH THIS UNIT. THE OPENING BETWEEN THE INSIDE WALLS MUST BE AT LEAST 28-1/2" WIDE.

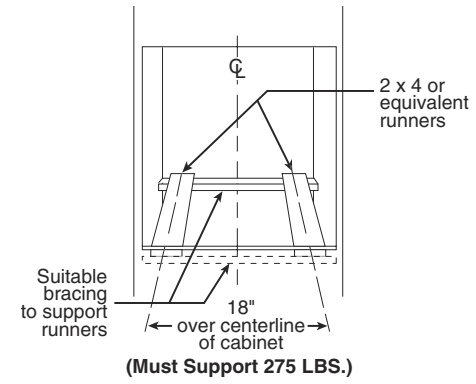

All GE ranges are equipped with an Anti-Tip device. The installation of this device is an important, required step in the installation of the range.



Listed by Underwriters Laboratories

JTP28BF/CF/WF

GE® 30" Built-In Double Oven

Features and Benefits

- Self Clean Oven (upper oven only) - Conveniently cleans the upper oven cavity without need of scrubbing
- Super-Large Oven Capacity - Provides the impressively large oven interior for cooking more dishes and large meals at one time
- Electronic Oven Controls - One-touch electronic pads are easy-to-use and allow for simple oven operation
- TrueTemp™ System - Delivers even heat distribution and maximum oven control
- Big ClearView™ Window - An extra large clear window makes monitoring the progress of the food easy
- Interior Oven Light - Supplies light to make viewing the progress of cooking easy and convenient
- Dual Element Bake - Alternates the upper broiling element and the lower baking element for even heating and optimal baking results
- Model JTP28WFWW - White on white
- Model JTP28CFCC - Bisque on bisque
- Model JTP28BFBB - Black on black

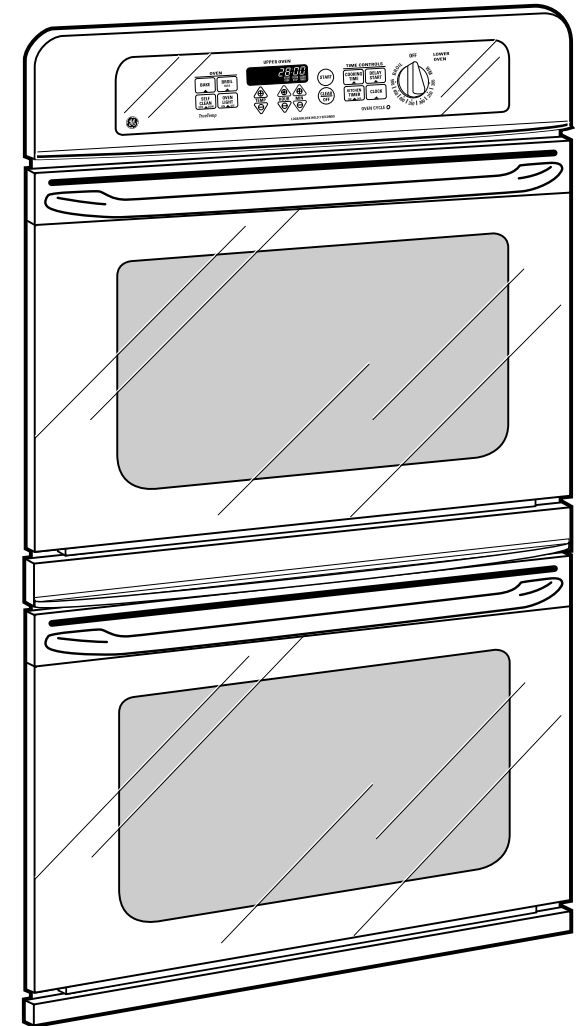

Free Manuals Download Website

<http://myh66.com>

<http://usermanuals.us>

<http://www.somanuals.com>

<http://www.4manuals.cc>

<http://www.manual-lib.com>

<http://www.404manual.com>

<http://www.luxmanual.com>

<http://aubethermostatmanual.com>

Golf course search by state

<http://golfingnear.com>

Email search by domain

<http://emailbydomain.com>

Auto manuals search

<http://auto.somanuals.com>

TV manuals search

<http://tv.somanuals.com>