



Illustrated Parts List

MODEL
040334-00

Not for
Reproduction

20,000 Watt
Home Generator System

Not for
Reproduction

PRODUCT COMPONENTS	PAGES
Main Unit	4
Alternator	6
Control Panel	8
Enclosure	10
Torque Specification Chart	Inside Back Cover

Not for
Reproduction

Exploded View - Main Unit

NOTE: Unless noted otherwise, use the standard hardware torque specification chart.

315432

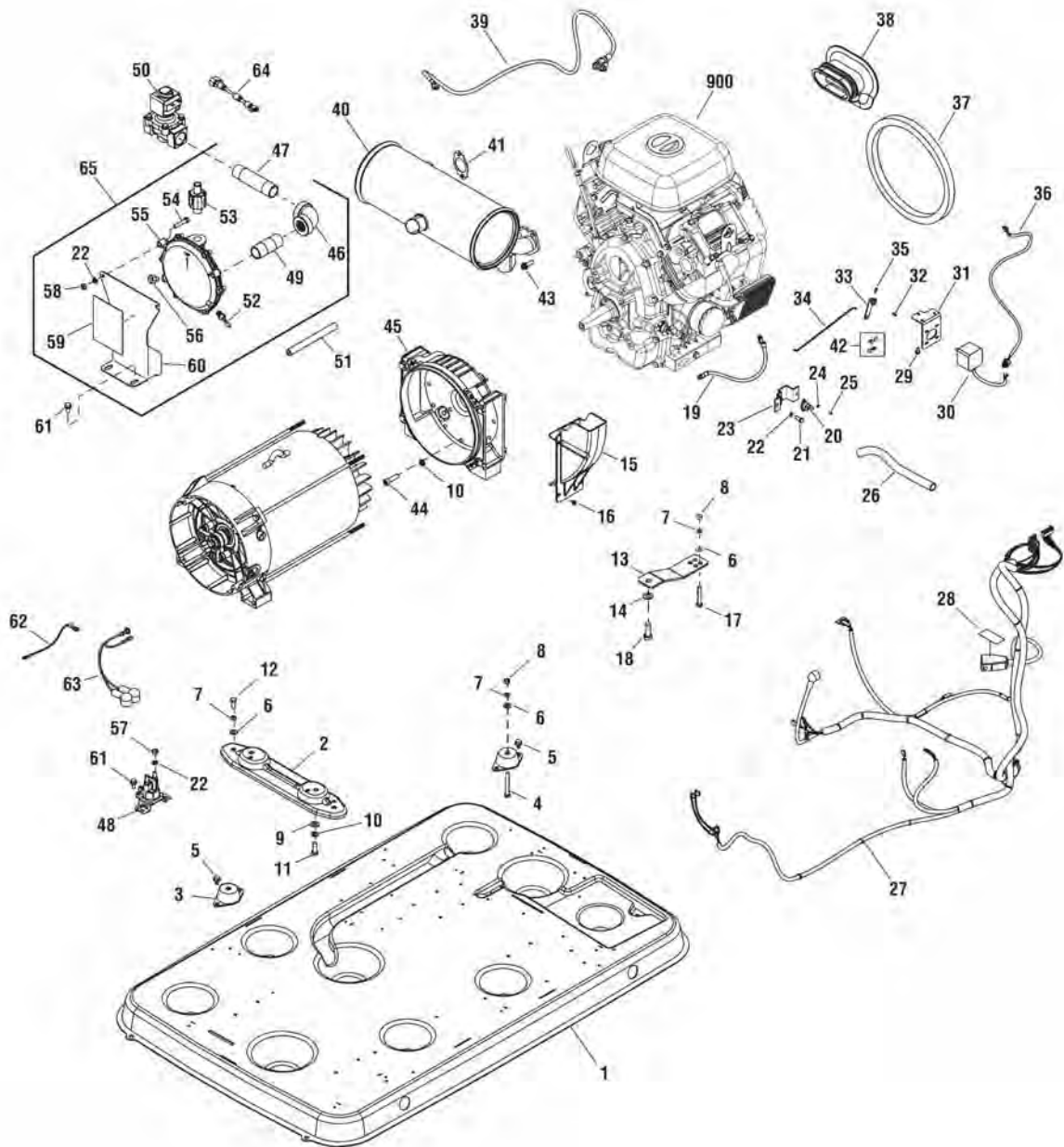

The above parts group applies to the following Mfg. Nos.:

040334-00 - 20,000 Watt Home Standby Generator (GE)

Parts List - Main Unit

Ref.	Part No.	Description	Ref.	Part No.	Description
1	B314636GS	BASE	45	195235GS	ADAPTER, Engine
2	B198896GS	BRACKET	46	312781GS	ELBOW
3	187594GS	MOUNT, Vibration	47	318459GS	FITTING
4	----	* CAPSCREW, Hex Head, 5/16-18 x 2-1/2	48	691656	SOLENOID, Starter
5	24910GS	SCREW	49	206976GS	FITTING
6	----	* WASHER, Flat, M8	50	318196GS	SOLENOID
7	----	* WASHER, Lock, M8	51	314662GS	TUBE
8	----	* NUT, 5/16-18	52	314693GS	FITTING, Barb
9	----	* WASHER, Flat, M10	53	845702	VALVE, LP/NG Switch
10	----	* WASHER, Lock, 3/8	54	----	* CAPSCREW, Hex Head, M6-1.0 x 30
11	----	* CAPSCREW, Hex Head, 3/8-16 x 1	55	845046GS	REGULATOR
12	----	* CAPSCREW, Hex Head, 5/16-18 x 3/4	56	318002GS	FITTING
13	B194685GS	BRACKET	57	----	* NUT, 1/4-20
14	----	* WASHER, Flat, M12	58	----	* NUT, Hex, M6-1
15	314628GS	DUCT	59	318449GS	DECAL SHEET, Warnings
16	----	* SCREW, M5-0.8 x 10	60	314629GS	BRACKET
17	----	* CAPSCREW, Hex Head, 5/16-18 x 2	61	B4300GS	BOLT
18	197487GS	CAPSCREW, Hex Head, M12-1.75 x 35	62	316961GS	WIRE, Ground Relay
19	314641GS	WIRE, Ground	63	316188GS	HARNESS
20	204426GS	SWITCH, Temp	64	318195GS	FUSE ASSEMBLY
21	47411GS	CAPSCREW, Hex Head, M6-1.0 x 16	65	703877	FUEL REGULATOR ASSEMBLY (Includes Ref. Nos. 46, 47, 49, 52, 53, 55, 56, 58 & 59)
22	----	* WASHER, Lock, 1/4	900	----	** ENGINE
23	313561GS	PLATE, Switch	--	314669GS	MANUAL, Install (Not Illustrated)
24	----	* WASHER, Shakeproof, #4	--	314673GS	MANUAL, Operator (Not Illustrated)
25	186242GS	SCREW	--	318875GS	KIT, Manual, Acc. (Not Illustrated)
26	5048681SM	HOSE, Oil	--	318973GS	KIT, Hardware (Not Illustrated)
27	314637GS	HARNESS, Wiring	--	316198GS	ANTENNA (Not Illustrated)
--	318449GS	DECAL SHEET, Warnings	--	311713GS	HOSE, Flex (Not Illustrated)
28	318449GS	DECAL SHEET, Warnings	--	312758GS	PAINT, Touch Up, GE Bronze (Not Illustrated)
29	194561GS	SCREW	--	195200GS	HANG TAG, Attn. Standby Equipment (Not Illustrated)
30	317479GS	STEPPER MOTOR	--	316196GS	BSC MONITOR (Not Illustrated)
31	317255GS	BRACKET	--	315008GS	PAINT, Spray, GE Bronze (Optional Accessory)
32	----	* CAPSCREW, Hex Head, M3-0.5 x 6	--	314941GS	BATTERY WARMER (Optional Accessory)
33	317324GS	ARM, Link	--	6036	KIT, Maintenance (Optional Accessory)
34	317323GS	ROD	--	6231	KIT, Cold Weather (Includes Battery & Oil Warmers) (Optional Accessory)
35	----	* CAPSCREW, Hex Head, M3-0.5 x 8	--	6254	KIT, Cold Weather (Includes Oil Warmers) (Optional Accessory)
36	317480GS	HARNESS, Wiring			
37	315454GS	SEAL			
38	314642GS	SNORKEL			
39	314640GS	WIRE, Battery, Ground			
40	314663GS	MUFFLER			
41	809872	GASKET			
42	845699	CLEVIS			
43	----	* SCREW, M8 x 25			
44	23645GS	SCREW			

Footnotes:

* Items without part numbers are common fasteners and are available at your local hardware store.

** Contact Engine Manufacturer for parts and service.

The above parts group applies to the following Mfg. Nos.:

040334-00 - 20,000 Watt Home Standby Generator (GE)

Exploded View - Alternator

NOTE: Unless noted otherwise, use the standard hardware torque specification chart.

318313

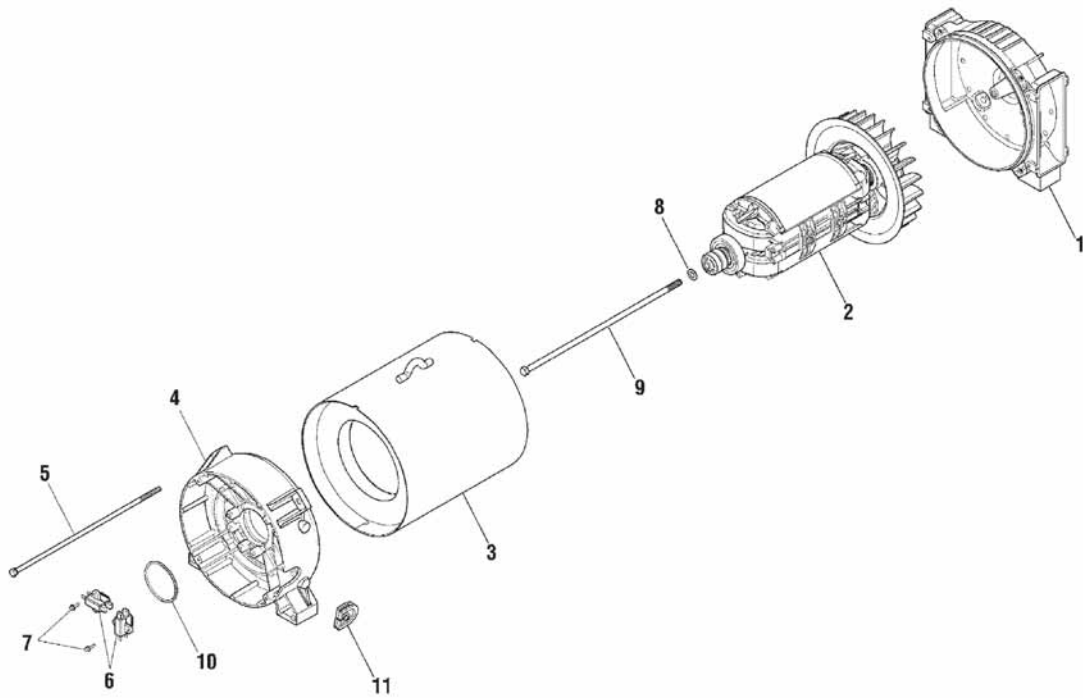

The above parts group applies to the following Mfg. Nos.:

040334-00 - 20,000 Watt Home Standby Generator (GE)

Parts List - Alternator

Ref.	Part No.	Description	Ref.	Part No.	Description
1	195235GS	ADAPTER, Engine			
2	314664GS	ROTOR			
3	314666GS	STATOR			
4	195234GS	RBC			
5	315199GS	SCREW			
6	66386GS	BRUSH ASSEMBLY			
7	66849GS	TAPTITE			
8	203200GS	WASHER			
9	315204GS	BOLT			
10	199888GS	O-RING			
11	315440GS	GROMMET			

Not for
Reproduction

Footnotes:

The above parts group applies to the following Mfg. Nos.:

040334-00 - 20,000 Watt Home Standby Generator (GE)

Exploded View - Control Panel

NOTE: Unless noted otherwise, use the standard hardware torque specification chart.

318322

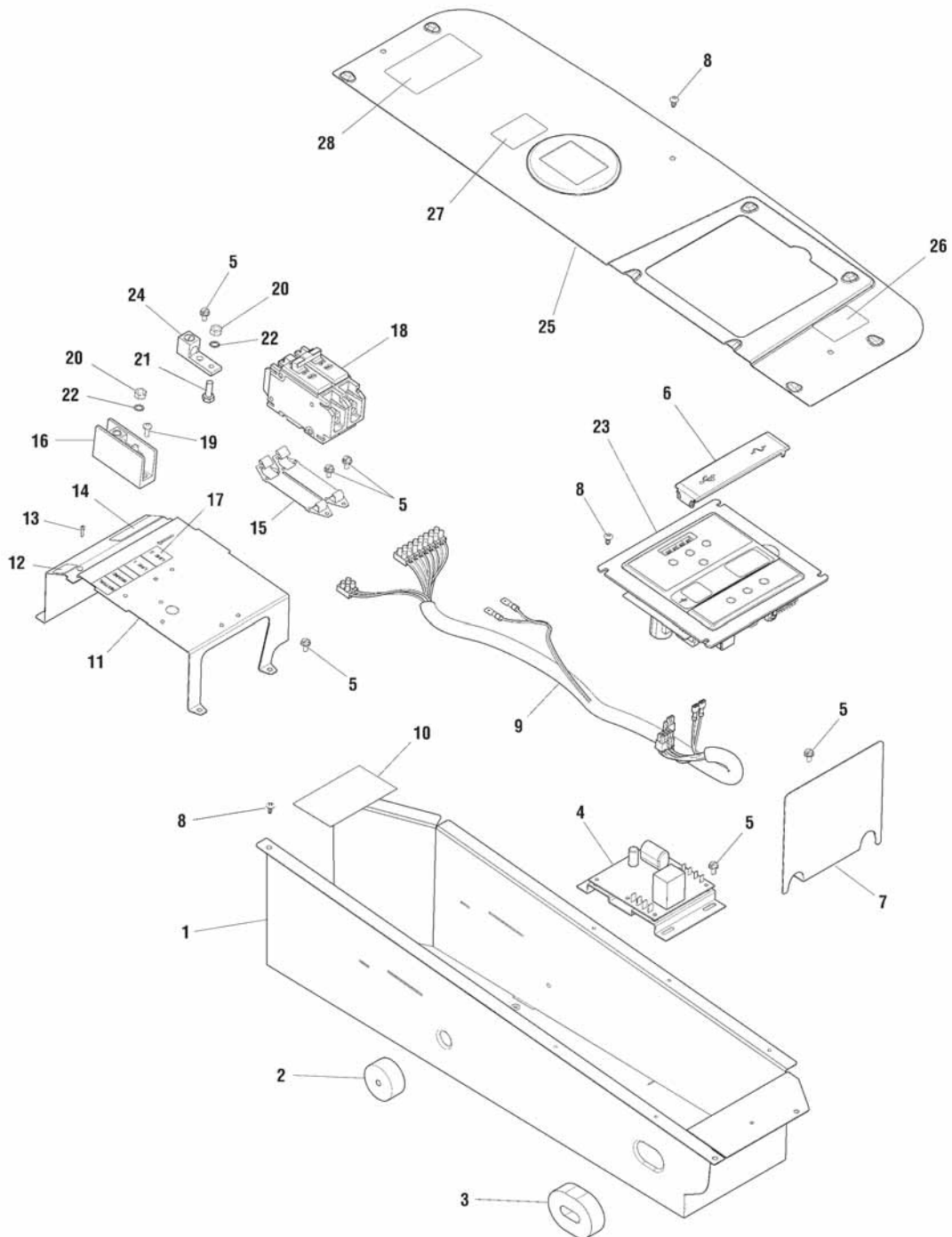

The above parts group applies to the following Mfg. Nos.:

040334-00 - 20,000 Watt Home Standby Generator (GE)

Parts List - Control Panel

Ref.	Part No.	Description	Ref.	Part No.	Description
1	314631GS	BOX, Control			
2	316948GS	SEAL			
3	316205GS	SEAL			
4	205479GS	REGULATOR, Voltage			
5	-----	* BOLT, Hex Head, #10-32 x 3/8			
6	319009GS	DOOR, Access			
7	314632GS	BRACKET			
8	-----	* SCREW, #10-32 x 3/8			
9	314639GS	HARNESS			
10	318449GS	DECAL SHEET, Warnings			
11	314633GS	BRACKET			
12	317371GS	DECAL			
13	-----	* SCREW, M2.5-0.45 x 8			
14	317368GS	DECAL			
15	192770GS	BRACKET			
16	208365GS	TERMINAL BLOCK			
17	313585GS	DECAL			
18	311318GS	BREAKER, Circuit			
19	-----	* SCREW, #10-32 x 3/4			
20	-----	* NUT, 1/4-20			
21	-----	* CAPSCREW, Hex Head, 1/4-20 x .75			
22	-----	* WASHER, External Lock, M6			
23	314618GS	CONTROL PANEL			
24	199011GS	LUG			
25	B314635GS	COVER, Control Panel Box			
26	318449GS	DECAL SHEET, Warnings			
27	318449GS	DECAL SHEET, Warnings			
28	318449GS	DECAL SHEET, Warnings			
--	198573GS	FUSE			

Footnotes:

* Items without part numbers are common fasteners and are available at your local hardware store.

The above parts group applies to the following Mfg. Nos.:

040334-00 - 20,000 Watt Home Standby Generator (GE)

Exploded View - Enclosure

NOTE: Unless noted otherwise, use the standard hardware torque specification chart.

315435

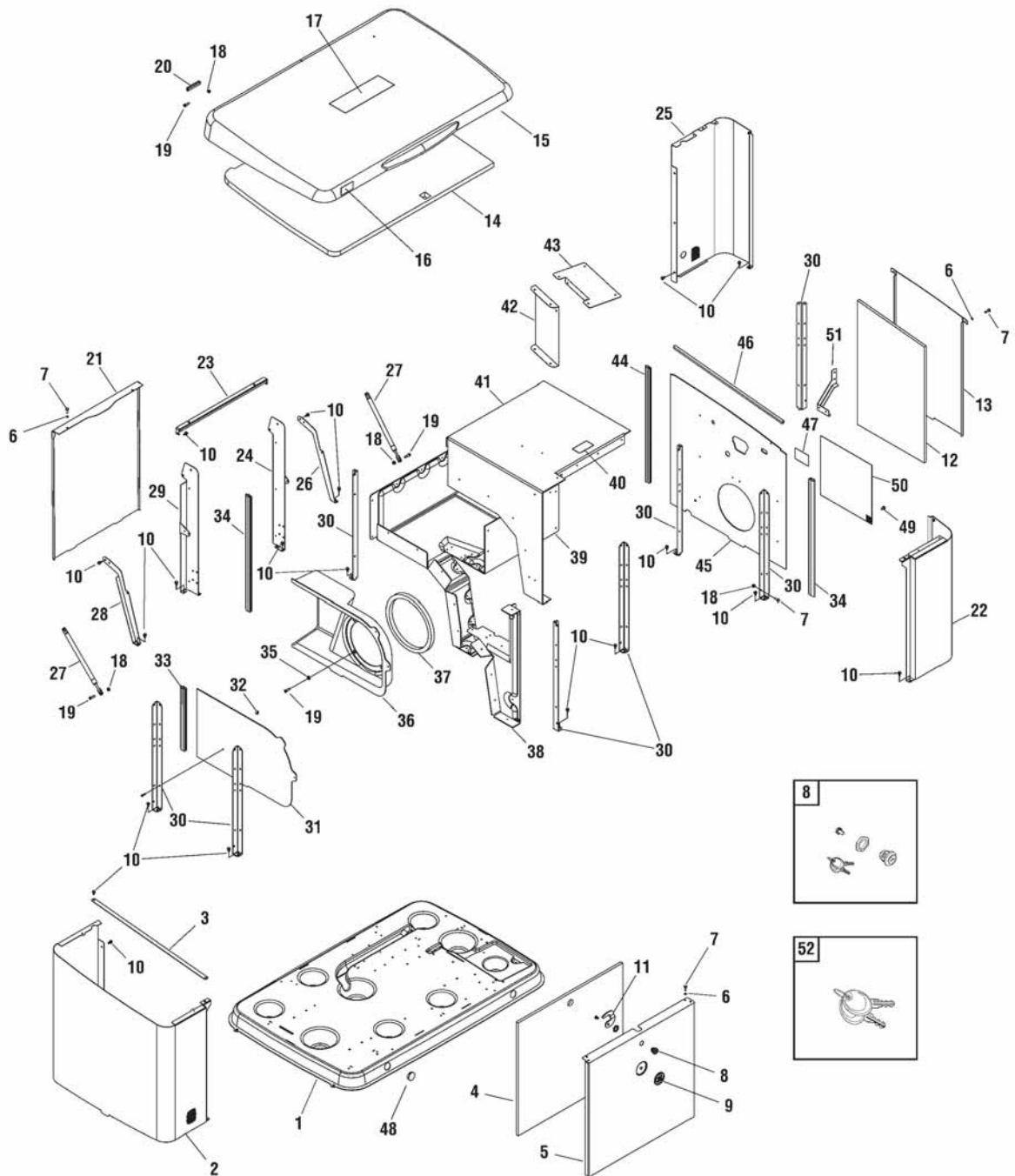

The above parts group applies to the following Mfg. Nos.:

040334-00 - 20,000 Watt Home Standby Generator (GE)

Parts List - Enclosure

Ref.	Part No.	Description	Ref.	Part No.	Description
1	B314636GS	BASE	46	316202GS	TRIM
2	AL314645GS	PANEL, End, Left	47	205392GS	DECAL
3	314638GS	SUPPORT, Rail	48	198460GS	PLUG
4	315447GS	INSULATION	49	194561GS	SCREW
5	318242GS	PANEL, Front	50	316194GS	SCREEN
6	-----	* WASHER, External Lock, M6	51	315444GS	SUPPORT
7	-----	* CAPSCREW, Hex Head, 1/4-20 x 3/4	52	314290GS	KEY, Latch
8	314619GS	LATCH	--	316193GS	PLUG, Roof
9	207095GS	BADGE			
10	B4300GS	BOLT			
11	315443GS	LATCH, Arm			
12	315453GS	INSULATION			
13	AL314694GS	PANEL, End, Right			
14	315452GS	INSULATION			
15	318232GS	ROOF			
16	318449GS	DECAL SHEET, Warnings			
17	317921GS	DECAL			
18	-----	* NUT, Flange, 1/4-20			
19	311644GS	SCREW			
20	316954GS	TRIM			
21	AL314651GS	PANEL, Back			
22	AL314681GS	PANEL, Corner			
23	314652GS	SUPPORT-RAIL			
24	314647GS	BRACKET, Roof Support			
25	AL314644GS	PANEL, Corner			
26	314646GS	BRACE			
27	314649GS	SPRING			
28	314672GS	BRACE			
29	314679GS	BRACKET, Roof Support			
30	314625GS	SUPPORT			
31	314684GS	PANEL, Intake, Alternator			
32	314661GS	CLIP			
33	314682GS	SEAL			
34	311692GS	SEAL			
35	-----	* WASHER, Flat, M8			
36	314626GS	DUCT, Alternator			
37	315454GS	SEAL			
38	314624GS	PANEL, Muffler			
39	314620GS	PANEL, Muffler, Bottom			
40	318449GS	DECAL SHEET, Warnings			
41	314621GS	PANEL, Muffler, Top			
42	314699GS	DEFLECTOR, Muffler			
43	317254GS	DEFLECTOR, Exhaust			
44	316951GS	SEAL			
45	314683GS	PANEL, Intake, Engine			

Footnotes:

* Items without part numbers are common fasteners and are available at your local hardware store.

The above parts group applies to the following Mfg. Nos.:

040334-00 - 20,000 Watt Home Standby Generator (GE)

Not for
Reproduction

Not for
Reproduction

Not for
Reproduction

Hardware Identification & Torque Specifications

Torque Specification Chart FOR STANDARD METRIC MACHINE HARDWARE (Tolerance ± 20%)								
Property Class	5.6 Class 5.6		8.8 Class 8.8		10.9 Class 10.9		12.9 Class 12.9	
Size Of Hardware	in/lbs ft/lbs	Nm.	in/lbs ft/lbs	Nm.	in/lbs ft/lbs	Nm.	in/lbs ft/lbs	Nm.
M3	5.88	.56	13.44	1.28	19.2	1.80	22.92	2.15
M4	13.44	1.28	30.72	2.90	43.44	4.10	52.56	4.95
M5	26.4	2.50	60.96	5.75	5.97	8.10	7.15	9.7
M6	44.64	4.3	7.3	9.9	10.3	14	12.1	16.5
M7	5.2	7.1	12.1	16.5	16.9	23	19.9	27
M8	7.7	10.5	17.7	24	25	34	29	40
M10	15	21	35	48	50	67	59	81
M12	26	36	61	83	86.2	117	103	140
M14	42	58	101	132	136	185	162	220
M16	64	88	147	200	210	285	250	340
M18	89	121	202	275	287	390	346	470
M20	126	171	290	390	405	550	486	660
M22	169	230	390	530	559	745	656	890
M24	217	295	497	375	708	960	840	1140
M27	320	435	733	995	1032	1400	1239	1680
M30	435	590	995	1350	1401	1900	1681	2280
M33	590	800	1349	1830	1902	2580	2278	3090
M36	759	1030	1740	2360	2441	3310	2935	3980
M39	988	1340	2249	3050	3163	4290	3798	5150

The guides and ruler furnished below are designed to help you select the appropriate hardware.

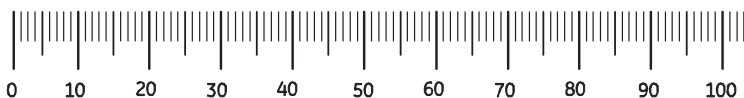

Nut, M8

Thread Diameter (mm)
Inside Diameter (in)
Threads per inch

Nut, 1/2-16

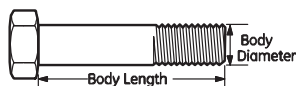

Screw, M8- 1.25 x 25

Thread Diameter (mm)
Body Diameter
Distance between threads (mm)
Threads per inch
Body Length (mm)
Body Length (in)

Screw, 1/2- 16 x 2

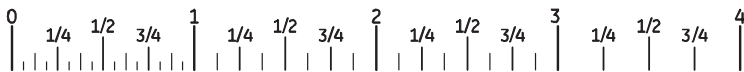

Standard Hardware Sizing

When a washer or nut is identified as **1/2" (M8)**, this is the *Nominal size*, meaning the *inside diameter* is 1/2 inch (8mm metric thread diameter); if a second number is present it represents the *threads per inch* (distance between threads),

When bolt or capscrew is identified as **1/2-16 x 2"** (M8 - 1.25 x 50), this means the *Nominal size*, or body diameter is 1/2 inch (8mm metric thread diameter), the second number, 16, represents the *threads per inch*, (1.25 thread diameter). The final number is the body length of the bolt or screw, 2 inches (50mm).

Torque Specification Chart FOR STANDARD MACHINE HARDWARE (Tolerance ± 20%)						
Hardware Grade	No Marks SAE Grade 2		SAE Grade 5		SAE Grade 8	
Size Of Hardware	in/lbs ft/lbs	Nm.	in/lbs ft/lbs	Nm.	in/lbs ft/lbs	Nm.
8-32	19	2.1	30	3.4	41	4.6
8-36	20	2.3	31	3.5	43	4.9
10-24	27	3.1	43	4.9	60	6.8
10-32	31	3.5	49	5.5	68	7.7
1/4-20	66	7.6	8	10.9	12	16.3
1/4-28	76	8.6	10	13.6	14	19.0
5/16-18	11	15.0	17	23.1	25	34.0
5/16-24	12	16.3	19	25.8	29	34.0
3/8-16	20	27.2	30	40.8	45	61.2
3/8-24	23	31.3	35	47.6	50	68.0
7/16-14	30	40.8	50	68.0	70	95.2
7/16-20	35	47.6	55	74.8	80	108.8
1/2-13	50	68.0	75	102.0	110	149.6
1/2-20	55	74.8	90	122.4	120	163.2
9/16-12	65	88.4	110	149.6	150	204.0
9/16-18	75	102.0	120	163.2	170	231.2
5/8-11	90	122.4	150	204.0	220	299.2
5/8-18	100	136	180	244.8	240	326.4
3/4-10	160	217.6	260	353.6	386	525.0
3/4-16	180	244.8	300	408.0	420	571.2
7/8-9	140	190.4	400	544.0	600	816.0
7/8-14	155	210.8	440	598.4	660	897.6
1-8	220	299.2	580	788.8	900	1,244.0
1-12	240	326.4	640	870.4	1,000	1,360.0

NOTES

- These torque values are to be used for all hardware excluding: locknuts, self-tapping screws, thread forming screws, sheet metal screws and socket head setscrews.
- Recommended seating torque values for locknuts:
 - for prevailing torque locknuts - use 65% of grade 5 torques.
 - for flange whizlock nuts and screws - use 135% of grade 5 torques.
- Unless otherwise noted on assembly drawings, all torque values must meet this specification.

Common Hardware Types

Hex Head Capscrew

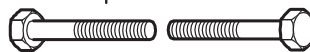

Washer

Carriage Bolt



Lockwasher



Hex Nut

Wrench & Fastener Size Guide

1/4" Bolt or Nut Wrench—7/16"	5/16" Bolt or Nut Wrench—1/2"	3/8" Bolt or Nut Wrench—9/16"	7/16" Bolt or Nut Wrench (Bolt)—5/8" Wrench (Nut)— 11/16"	1/2" Bolt or Nut Wrench—3/4"
M6 Bolt or Nut Wrench—10mm	M8 Bolt or Nut Wrench—13mm	M10 Bolt or Nut Wrench—17mm	M12 Bolt or Nut Wrench—19mm	M14 Bolt or Nut Wrench—22 mm



Not for
Reproduction



is a trademark of General Electric company
and is under licensed by Briggs & Stratton
Power Products Group, LLC.

Copyright © 2013. All Rights reserved. No part of this material may
be reproduced or transmitted in any form without the express
written permission of Briggs & Stratton Power Products Group, LLC.

Free Manuals Download Website

<http://myh66.com>

<http://usermanuals.us>

<http://www.somanuals.com>

<http://www.4manuals.cc>

<http://www.manual-lib.com>

<http://www.404manual.com>

<http://www.luxmanual.com>

<http://aubethermostatmanual.com>

Golf course search by state

<http://golfingnear.com>

Email search by domain

<http://emailbydomain.com>

Auto manuals search

<http://auto.somanuals.com>

TV manuals search

<http://tv.somanuals.com>