

**GENERAC**<sup>®</sup>  
POWER SYSTEMS, INC.

**2.4**

***MITSUBISHI  
GAS  
ENGINE***

---

***SERVICE  
MANUAL***

# FOREWORD

This manual has been published by GENERAC<sup>®</sup> POWER SYSTEMS, INC. to aid our dealers' mechanics, company service personnel and general consumers when servicing the products described herein.

It is assumed that these personnel are familiar with the servicing procedures for these products, or like or similar products, manufactured and marketed by GENERAC<sup>®</sup> POWER SYSTEMS, INC. It is also assumed that they have been trained in the recommended servicing procedures for these products, which includes the use of mechanics hand tools and any special tools that might be required.

Proper service and repair is important to the safe, economical and reliable operation of the products described herein. The troubleshooting, testing, service and repair procedures recommended by GENERAC<sup>®</sup> POWER SYSTEMS, INC. and described in this manual are effective methods of performing such operations. Some of these operations or procedures may require the use of specialized equipment. Such equipment should be used when and as recommended.

We could not possibly know of and advise the service trade of all conceivable procedures or methods by which a service might be performed, nor of any possible hazards and/or results of each procedure or method. We have not undertaken any such wide evaluation. Therefore, anyone who uses a procedure or method not recommended by the manufacturer must first satisfy himself that neither his safety, nor the product's safety, will be endangered by the service or operating procedure selected.

All information, illustrations and specifications contained in this manual are based on the latest product information available at the time of publication. However, GENERAC<sup>®</sup> POWER SYSTEMS, INC. reserves the right to change, alter or otherwise improve the product at any time without prior notice.

Some components or assemblies of the product described in this manual may not be considered repairable. Disassembly, repair and reassembly of such components may not be included in this manual.

The engines described herein may be used to power a wide variety of products. Service and repair instructions relating to any such products are not covered in this manual. For information pertaining to use of these engines with other products, refer to any owner's or service manuals pertaining to said products.

SERVICE RECOMMENDATIONS ..... A\_2  
MITSUBISHI CONTENTS .....

This engine has been engineered for use in Generac Power Systems products. The contents of this manual have been reprinted from the original manufacturer's service and repair manual.

## 2.4 Liter Gas Engine Service Recommendations

### ◆ ENGINE OIL RECOMMENDATIONS

The unit has been filled with “break in” engine oil at the factory. Use a high-quality detergent oil classified “For Service CC, SD, SE or SF.” Detergent oils keep the engine cleaner and reduce carbon deposits. Use oil having the following SAE viscosity rating, based on the ambient temperature range anticipated before the next oil change:

Temperature	Oil Grade (Recommended)
Above 75° F (24° C)	SAE 30W
40° to 75° F (4.4° to 24° C)	SAE 20W or 15W-40
10° to 40° F (-12° to 4.4° C)	SAE 10W or 15W-40
Below 10° F (-12° C)	SAE 5W-30 (Synthetic) or 5W-20

Crankcase Oil Capacity..... 1.125 U.S. Gallons (w/filter)

### ◆ COOLANT

Use a mixture of half low silicate, ethylene glycol base antifreeze and half soft water. Use only soft water and only low silicate antifreeze. If desired, you may add a high quality rust inhibitor to the recommended coolant mixture. When adding coolant, always add the recommended 50-50 mixture.

Coolant Capacity..... 1.80 U.S. gallons



Do not remove the radiator pressure cap while the engine is hot or serious burns from boiling liquid or steam could result.



**DANGER**



Ethylene glycol base antifreeze is poisonous. Do not use your mouth to siphon coolant from the radiator, recovery bottle or any container. Wash your hands thoroughly after handling. Never store used antifreeze in an open container because animals are attracted to the smell and taste of antifreeze even though it is poisonous to them.



**CAUTION**



Do not use any chromate base rust inhibitor with ethylene glycol base antifreeze, or chromium hydroxide (“green slime”) will form and cause overheating. Engines that have been operated with a chromate base rust inhibitor must be chemically cleaned before adding ethylene glycol base antifreeze. Using any high silicate antifreeze boosters or additives also will cause overheating. We also recommend that you DO NOT use any soluble oil inhibitor for this equipment.

### 8 KW - 35 KW SMALL STANDBY GENERATOR SETS

Following is a recommended maintenance schedule for Generac small standby and residential generator sets from 8 kW to 35 kW in size, and applies to both diesel engine and gas engine driven units. The established intervals in the schedule are the *maximum* recommended when the unit is used in an average service application. They will need to be decreased (performed more frequently) if the unit is used in a severe application. Use the unit hour meter or calendar time, whichever occurs first, from the previous maintenance interval to determine the next required maintenance interval.

#### Service Maintenance Interval Information:

The various service maintenance intervals are designated by interval numbers as follows:

- 1 An early inspection of the generator set to insure it is ready to operate when required and to identify any potential problem areas.

*Performed monthly or following each 10 hours of operation of the unit and requires approximately .5 man-hours per unit to complete.*

This inspection may be performed by the end user providing the following safety steps are taken to prevent the engine from starting automatically without warning:

**To prevent injury, perform the following steps in the order indicated before starting any maintenance:**

- **Disable the generator set from starting and/or connecting to the load by setting the control panel Auto-Off-Manual switch to the "OFF" position.**
- **Remove the control panel fuse.**
- **Turn off the battery charger.**
- **Remove the negative battery cable.**



The battery charger must be turned off BEFORE removing the battery cable to prevent an over current condition from burning out sensitive control panel components and circuits.

**Following all maintenance, reverse these steps to insure the unit is returned to standby setup for normal operation when required.**

- 2 A break-in service inspection of the generator set to insure it is ready to operate and carry the load when required, and to identify any potential problem areas.

*Performed **ONLY ONCE** following the first three months or the first 30 hours of operation after purchase of the unit and requires approximately 2.5 man-hours per unit to complete.*

This inspection contains some maintenance tasks which require special tools, equipment, and/or knowledge to accomplish and should be performed only by an authorized Generac Service Dealer.

- 3 An operational inspection of the generator set to insure it is ready to operate and carry the load when required, and to identify any potential problem areas.

*Performed semi-annually or following each 50 hours of operation of the unit and requires approximately 1.5 man-hours per unit to complete.*

This inspection contains some maintenance tasks which require special tools, equipment, and/or knowledge to accomplish and should be performed only by an authorized Generac Service Dealer.

- 4 A mid-level inspection of the generator set to insure it is ready to operate and carry the load when required, and to identify any potential problem areas.

*Performed annually or following each 100 hours of operation of the unit and requires approximately 4.0 man-hours per unit to complete.*

This inspection contains some maintenance tasks which require special tools, equipment, and/or knowledge to accomplish and should be performed only by an authorized Generac Service Dealer.

# Liter Gas Engine Service Recommendations

Maintenance Tasks	Level 1		Level 2		Level 3		Level 4	
	Recommended to be done monthly/ 10 hrs.	Task Comp. (Date-Initials)	Required to be done 3 months/ Break-in /30 hrs.	Task Comp. (Date-Initials)	Required to be done Semi-Annually/50 hrs.	Task Comp. (Date-Initials)	Required to be done Annually/ 100 hrs.	Task Comp. (Date-Initials)
1.Disable the unit from operating per the first page warning.	●		●		●		●	
2.Check the engine oil level. Adjust as necessary.	●		●		●		●	
3.Check the engine coolant level. Adjust as necessary.	●		●		●		●	
4.Check the engine coolant thermal protection level. Correct as necessary.							●	
5.Check the natural gas delivery system on gas engine driven units. Tighten connections as necessary.			●		●		●	
6.Check the diesel fuel supply level for diesel engine driven units. Fill as necessary.	●		●		●		●	
7.Drain water and sediment from the diesel fuel tank on diesel engine driven units.			●		●		●	
8.Drain water from the fuel line water separator on diesel engine driven units if the unit is equipped with one.			●		●		●	
9.Check the air inlets and outlets for debris. Clean as necessary.	●		●		●		●	
10.Check the battery electrolyte level if accessible. Adjust as necessary.	●		●		●		●	
11.Check the battery posts, cables, and charger for loose connections, corrosion, and proper operation. Correct as necessary.	●		●		●		●	
12.Check the unit wiring for loose connections, corrosion, and damage. Correct as necessary.							●	
13.Check the engine accessory drive belts for wear, weather cracking, and damage. Replace as necessary.							●	

## 2.4 Liter Gas Engine Service Recommendations

Maintenance Tasks	Level 1		Level 2		Level 3		Level 4	
	Recommended to be done monthly/ 10 hrs.	Task Comp. (Date-Initials)	Required to be done 3 months/ Break-in /30 hrs.	Task Comp. (Date-Initials)	Required to be done Semi-Annually/50 hrs.	Task Comp. (Date-Initials)	Required to be done Annually/ 100 hrs.	Task Comp. (Date-Initials)
14.Visually inspect the unit looking for leaks, wear or damage, loose connections or components, and corrosion. Correct as necessary.	●		●		●		●	
15.Test the engine and transfer switch safety devices. Correct and/or adjust as necessary.							●	
16.Initiate an automatic start and transfer of the unit to site load and exercise it for at least 1 hour looking for leaks, loose connections or components, and abnormal operating conditions. Correct as necessary.			●		●			
17.Start and exercise the unit at full rated load (use a load bank if the site load is not enough) for at least 2 hours looking for leaks, loose connections or components, and abnormal operating conditions. Correct as necessary.							●	
18.Change the engine oil.							●	
19.Replace the engine oil filter(s).			●				●	
20.Replace the engine air filter(s).			●				●	
21.Replace the engine fuel filter(s) on diesel engine driven units and re-prime the fuel system.			●				●	
22.Check the engine spark plugs on gas engine driven units. Clean and re-gap or replace as necessary.			●				●	
23.Perform a 5 minute no-load operational run of the unit looking for any post service problems.			●				●	
24.Return the unit to standby setup for operation when required.	●		●		●		●	





# GENERAC POWER SYSTEM

---

## 4G64 ENGINE

### CONTENTS

GENERAL INFORMATION .....	03
1. SPECIFICATIONS .....	03
ENGINE MODELS .....	03
GENERAL SPECIFICATIONS .....	03
SERVICE SPECIFICATIONS .....	04
TORQUE SPECIFICATIONS .....	07
SEALANTS .....	09
2. SPECIAL TOOLS .....	11
3. IGNITION SYSTEM .....	14
4. TIME BELT .....	15
5. WATER PUMP .....	24
6. ROCKER ARMS AND CAMSHAFT .....	26
7. CYLINDER HEAD, VALVES .....	30
8. FRONT CASE, SILENT SHAFT AND OIL PAN .....	36
9. PISTON AND CONNECTING ROD .....	45
10. CRANKSHAFT .....	54

**Shenyang Aerospace Mitsubishi Motors Engine Manufacturing Co., Ltd**

---

---

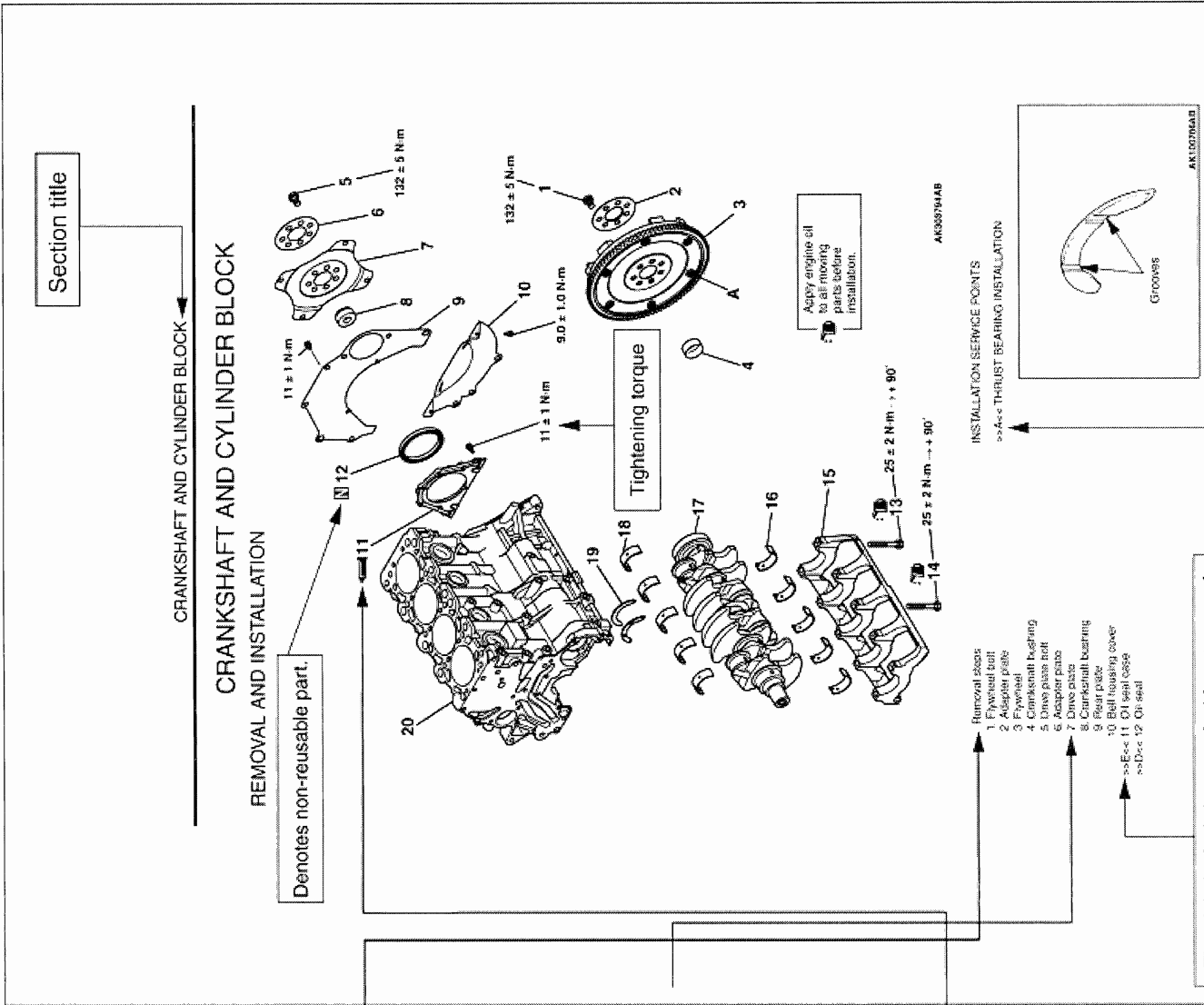

ction and service of

installed con-  
 ated as such,  
 quence.  
 everse.  
 ly sequence.  
 ps in reverse.

service points  
 service points

cket (FIG)

i general visual inspec-

## SPECIFICATIONS

# GENERAL INFORMATION

## ENGINE MODELS

Engine model	Displacement mL	Specification
4G64-D-Z8	2,351      2.4 L	Single overhead camshaft, 16-valve

## GENERAL SPECIFICATIONS

Description			Specification
Type			In-line OHV, SOHC
Number of cylinders			4
Combustion chamber			Pent roof type
Total displacement cm <sup>3</sup>			2,351
Cylinder bore mm			86.5
Piston stroke mm			100
Compression ratio			9.0
Valve timing	Intake valve	Opens (BTDC)	18°
		Closes (ABDC)	53°
	Exhaust valve	Opens (BBDC)	50°
		Closes (ATDC)	18°
Lubrication system			Pressure feed, full-flow filtration
Oil pump type			Involute gear type

## SPECIFICATIONS

# SERVICE SPECIFICATIONS

Item	Standard value	Limit	
<b>Timing belt</b>			
Auto-tensioner rod projection length mm	12	-	
Auto-tensioner rod pushed-in amount [When pushed with a force of 98 - 196 N] mm	1.0 or less	-	
<b>camshaft</b>			
Camshaft cam height mm	Intake	37.39	Min36.89
	Exhaust	36.83	Min36.33
Camshaft journal outside diameter mm	45	-	
<b>Cylinder head and valves</b>			
Cylinder head flatness of gasket surface mm	Less than 0.03	0.2	
Cylinder head grinding limit of gasket surface mm (Total resurfacing depth of cylinder head and cylinder block)	-	0.2	
Cylinder head overall height mm	119.9~ 120.1	-	
Cylinder head bolt shank length mm	97.4	99.4	
Valve thickness of valve head (margin) mm	Intake	1.0	Min 0.5
	Exhaust	1.2	Min 0.7
Valve overall height mm	Intake	112.30	Min111.80
	Exhaust	114.11	Min113.61
Valve stem outside diameter mm	6.0	-	
Valve thickness to valve guide clearance mm	Intake	0.02 - 0.05	0.10
	Exhaust	0.03 - 0.07	0.15
Valve face angle mm	45° - 45.5°	-	
Valve spring free length mm	51.0	50	
Valve spring load/installed height kg/mm	27.2/44.2	-	
Valve spring out-of-squareness	2° or less	4°	
Valve seat valve contact width mm	0.9 - 1.3	-	
Valve guide inside diameter mm	6.0	-	
Valve guide projection from cylinder head upper surface mm	14.0	-	
Valve stem projection mm	49.3	49.8	
<b>Oil pan and oil pump</b>			

## SPECIFICATIONS

Item	Standard value	Limit	Item
Oil pump side clearance mm	Drive gear	0.08 - 0.14	-
	Driven gear	0.06 - 0.12	-
<b>Piston and connecting rod</b>			
Piston outside diameter mm		86.5	-
Piston ring side clearance mm	No. 1	0.02 - 0.06	0.1
	No. 2	0.02 - 0.06	0.1
Piston ring end gap mm	No. 1	0.25 - 0.35	0.8
	No. 2	0.40 - 0.55	0.8
	Oil ring side rail	0.10 - 0.40	1.0
Piston pin outside diameter mm		22.0	-
Piston pin press-in load kg (Room temperature)		755-1750	-
Crankshaft pin oil clearance mm		0.02 - 0.05	0.1
Connecting rod big end side clearance mm		0.10 - 0.25	0.4
<b>Crankshaft and cylinder block</b>			
Crankshaft end play mm		0.05 - 0.18	0.25
Crankshaft journal outside diameter mm		57.0	-
Crankshaft pin outside diameter mm		45.0	-
Crankshaft journal oil clearance mm		0.02 - 0.04	0.1
Cylinder block flatness of gasket surface mm		0.05	0.1
Cylinder block grinding limit of gasket surface mm (Total resurfacing depth of both cylinder head and cylinder block)		-	0.2
Cylinder block overall height mm		290±0.1	-
Cylinder block inside diameter mm		86.5-86.53	-
Cylindricity mm		0.01	-

## SPECIFICATIONS

# REWORK DIMENSIONS

Item	Standard value		
<b>Cylinder head And valves</b>			
Diameter of oversize valve seat ring hole in cylinder head mm	Intake	0.3 oversize	34.435-34.455
		0.6 oversize	34.735-34.755
	Exhaust	0.3 oversize	31.935-31.955
		0.6 oversize	32.235-32.255
Diameter of oversize valve guide hole in cylinder head mm		0.05 oversize	11.05 - 11.07
		0.25 oversize	11.25 - 11.27
		0.50 oversize	11.50 - 11.52

SPECIFICATIONS

# TORQUE SPECIFICATIONS

Item	Specification(kg.m) / lbs /ft	
<b>ignition system</b>		
Ignition coil	1.0	7.2
Crankshaft pulley bolts	2.5	18
Spark plugs	2.5	18
Water pump pulley bolts	0.9	6.5
<b>Exhaust manifold</b>		
Water pump bolts	1.4	10
Thermostat housing bolts	2.4	17.5
<b>Timing belt</b>		
Auto-tensioner bolts	2.4	17.5
Camshaft sprocket bolt	9.0	65
Counterbalance shaft sprocket bolt	4.6	33
Crankshaft bolt	12	87
Engine support bracket bolt	4.9	35
Idler pulley bolt	3.6	26
Oil pump sprocket nut	5.5	40
Tensioner "B" bolt	1.9	14
Tensioner arm bolt	2.2	16
Tensioner pulley bolt	4.9	35
Timing belt cover bolts (Bolt, washer assembly)	1.1	8
Timing belt cover bolts (Flange bolt and nut)	1.1	8
<b>Inlet manifold and water pump</b>		
Engine hanger bolt	1.9	14
Oil pressure switch	1.0	7.2
Water temp gauge	3.0	21.5
Water outlet fitting bolts	2.0	14.5
<b>Rocker arms and camshaft</b>		
Rocker arms and rocker arm shaft bolts	3.2	23
Rocker cover bolts	0.4	3
Thrust screw	1.9	14

## SPECIFICATIONS

Item	Specification(kg.m)
<b>Cylinder head and valves</b>	
Cylinder head bolts	20 → +90° → +90°
<b>Oil pan and oil pump</b>	
Drain plug	4.5                      32.5
Flange bolt	3.7                        27
Front case bolts	2.4                        17.5
Oil filter bracket bolts	1.9                        14
Oil filter	1.9                        14
Oil pan bolts	0.7                        5
Oil pump cover bolts	1.6                        13
Oil pump cover screws	1.0                        7.2
Oil screen bolts	1.9                        14
Plug	2.4                        17.5
Relief plug	4.5                        32.5
<b>Piston and connecting rod</b>	
Connecting rod cap nuts	20 → +90° to 100°
<b>Crankshaft and cylinder block</b>	
Bearing cap bolts	2.5 → +90° to 100°
Bell housing cover bolts	0.9                        6.5
Oil seal case bolts	1.1                        8
Rear plate bolts	1.1                        8



## SPECIFICATIONS

# SEALANTS

Items	Specified sealants
Engine coolant temperature sensor	LOCTITE 262 or equivalent
Water outlet fitting*	Mitsubishi Genuine Part No. MD970389 or equivalent
Thermostat housing*	
Thermostat housing seal bolt	3M™ AAD Part No. 8672 or equivalent
Oil pressure switch	Three bond 1141E , 1215 or 1212D or equivalent
Oil pan*	Mitsubishi Genuine Part No. MD970389 or equivalent
Rear oil seal case*	
<b>note</b>	*: Part to be sealed with a form-in-place gasket (FIPG)

## FORM-IN-PLACE GASKET (FIPG)

This engine has several areas where the form-in-place gasket (FIPG) is used for sealing. To ensure that the FIPG fully serves its purpose, it is necessary to observe some precautions when applying it.

Bead size, continuity and location are of paramount importance. Too thin a bead could cause leaks. Too thick a bead, on the other hand, could be squeezed out of location, causing blocking or narrowing of fluid passages. To prevent leaks or blocking of passages, therefore, it is absolutely necessary to apply the FIPG evenly without a break, while observing the correct bead size.

FIPG hardens as it reacts with the moisture in the atmospheric air, and it is usually used for sealing metallic flange areas.

## REMOVAL OF FIPG SEALED PARTS

Parts sealed with a FIPG can be easily removed without need for the use of a special method. In some cases, however, the FIPG in joints may have to be broken by tapping parts with a mallet or similar tool. You can also tap a flat, thin gasket scraper into the joint to break the FIPG, taking extreme care not to damage the mating surfaces. The oil pan remover (MD998727) is available as a special tool for removing the oil pan. The tool, however, must not be

## CLEANING FIPG APPLICATION SURFACE





Thoroughly remove all substances deposited on the FIPG application surface, using a gasket scraper or wire brush. Make sure that the FIPG application surface is flat and smooth. Also make sure that the surface is free from oils, greases and foreign substances. Do not fail to remove old FIPG that may remain in the fastener fitting holes.

### APPLICATION OF FIPG



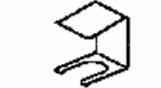
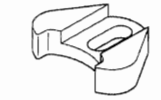
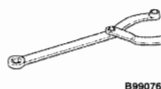
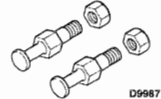

Applied FIPG bead should be of the specified size and free of any break. FIPG can be wiped away unless it has completely hardened. Install the mating parts in position while the FIPG is still wet (in less than 15 minutes after application). Do not allow FIPG to spread beyond the sealing areas during installation. Avoid operating the engine or letting oils or water come in contact with the sealed area before a time sufficient for FIPG to harden (approximately one hour) has passed. FIPG application method may vary from location to location. Follow the instruction for each particular case described later in this manual.

## SPECIAL TOOLS



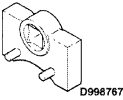
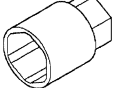
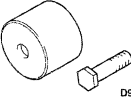
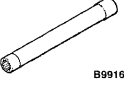

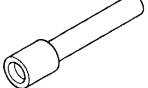
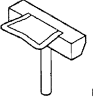

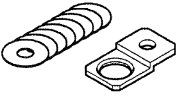
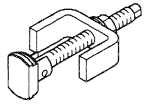
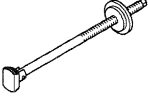
### SPECIAL TOOLS

Tool	Number	Name	Use
	MB990685	Moment wrench	Adjustment of timing belt tension
	MD998778	Crankshaft sprocket puller	Removal of crankshaft sprocket
	MD998440	Leak-down tester	Leak-down tester of lash adjuster
	MD998441	Lash adjuster retainer	Bleeding of air inside the adjuster
	MD998442	Air bleed wire	Air bleed of lash adjuster
	MD998443	Lash adjuster holder	Supporting of the lash adjuster to prevent it from falling when rocker shaft assembly is removed or installed
	MD998785	Sprocket stopper	Supporting counterbalance shaft sprocket
 B990767	MB990767	End yoke holder	Holding camshaft sprocket when loosening or torquing bolt
 D998719	MD998719	Pins	

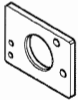
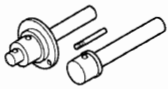
## SPECIAL TOOLS

 D998767	MD998767	Tension pulley wrench	Adjustment of timing belt tension
	MD998054	Oil pressure switch wrench	Removal and installation of oil pressure switch <to cylinder block>
 D998713	MD998713	Camshaft oil seal installer	Installation of camshaft oil seal
 B991654	MB991654	Cylinder head bolt wrench (12)	Removal and installation of cylinder head bolt
	MD998735	Valve spring compressor	Compression of valve spring
	MD998774	Valve steam seal installer	Installation of valve steam seal
 D998727	MD998727	Oil pan remover	Removal of oil pan
	MD998162	Plug wrench	Removal and installation of front case cap plug
	MD998783	Plug wrench retainer	
	MD998371	Silent shaft bearing puller	Removal of counterbalance shaft front bearing
	MD998372	Silent shaft bearing puller	Removal of counterbalance shaft rear bearing

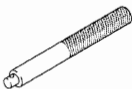
## SPECIAL TOOLS

	MB991603	Bearing installer stopper	Removal and installation of rear bearing
	MD998705	Silent shaft bearing installer	Installation of counterbalance shaft bearing
 <p style="font-size: small;">D998285</p>	MD998285	Crankshaft front oil seal guide	Installation of crankshaft front oil seal
	MD998375	Crankshaft front oil seal installer	
	MD998780	Piston pin setting tool	Removal and installation of piston pin
	MB990938	Handle	Installation of crankshaft rear oil seal
 <p style="font-size: small;">D998776</p>	MD998776	Crankshaft rear oil seal installer	

## IGNITION SYSTEM

### REMOVAL AND INSTALLATION

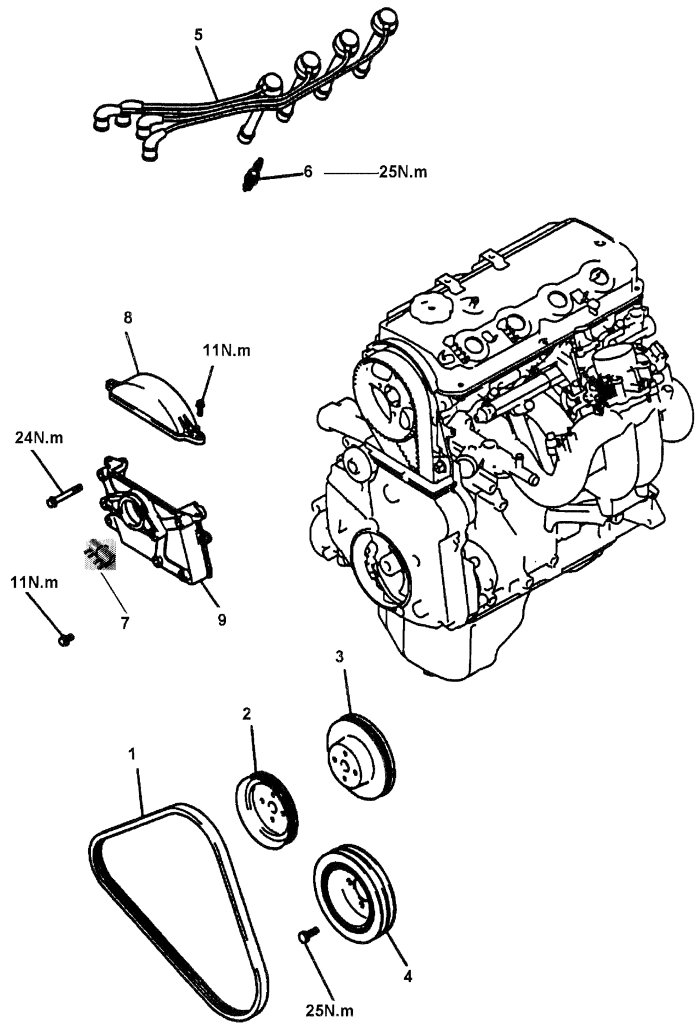

#### Removal steps

1. Drive belt
2. Water pump pulley
3. Power steering pump pulley
4. Crankshaft pulley
5. Spark plug cable
6. Spark plug
7. Ignition coil
8. Timing belt front upper cover
9. Ignition coil bracket

# TIME BELT

## REMOVAL AND INSTALLATION

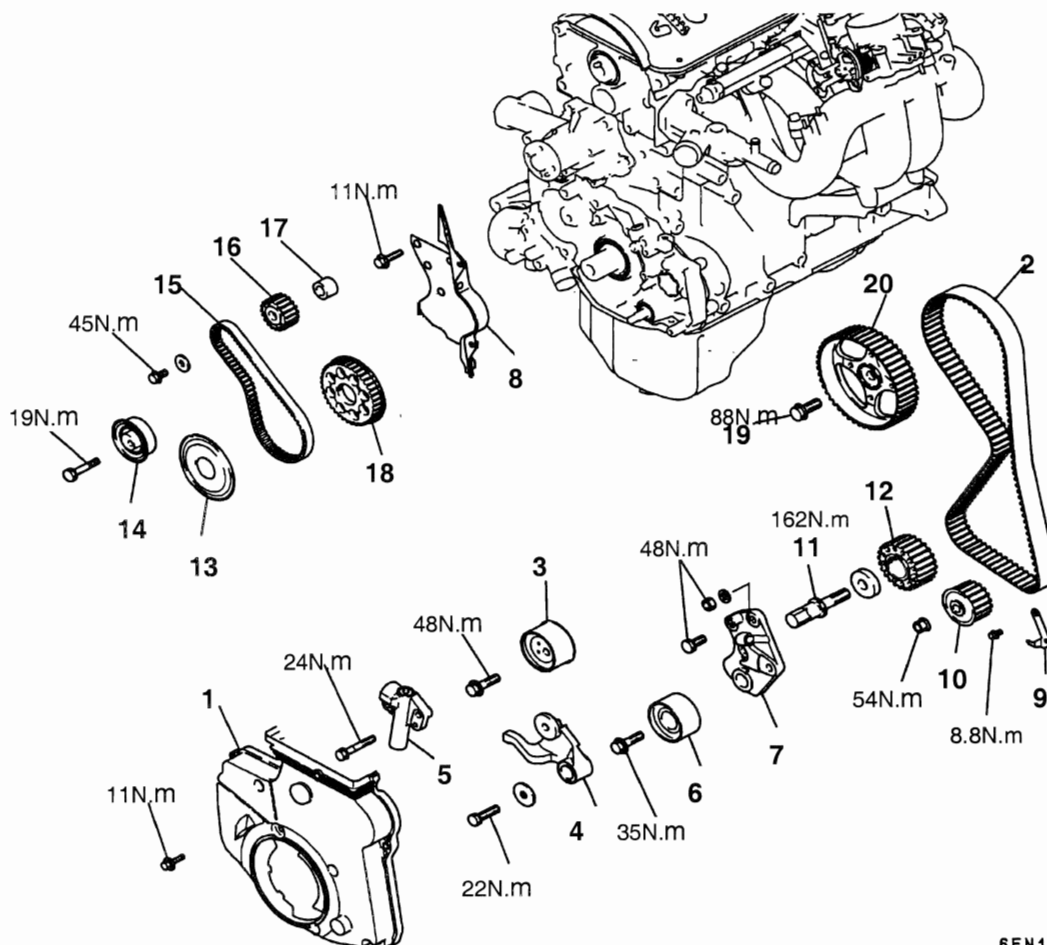

6EN1769

### Removal steps

- |       |                                  |                       |       |                                   |
|-------|----------------------------------|-----------------------|-------|-----------------------------------|
|       | 1. Timing belt front lower cover | <<C>>                 | >>E<< | 11. Crankshaft bolt               |
| <<A>> | >>H<<                            | 2. Timing belt        | <<D>> | 12. Crankshaft sprocket           |
|       | 3. Tensioner pulley              |                       |       | 13. Flange                        |
|       | 4. Tensioner arm                 |                       |       | 14. Tensioner "B"                 |
| >>G<< | 5. Auto-tensioner                | <<E>>                 | >>D<< | 15. Timing belt "B"               |
|       | 6. Idler pulley                  | <<F>>                 | >>C<< | 16. Counterbalance shaft sprocket |
|       | 7. Tensioner pulley bracket      |                       | >>B<< | 17. Spacer                        |
|       | 8. Timing belt rear cover        | <<G>>                 |       | 18. Crankshaft sprocket "B"       |
|       | 9. Timing belt indicator         | <<H>>                 | >>A<< | 19. Camshaft sprocket bolt        |
| <<B>> | >>F<<                            | 10. Oil pump sprocket |       | 20. Camshaft sprocket             |

## TIME BELT

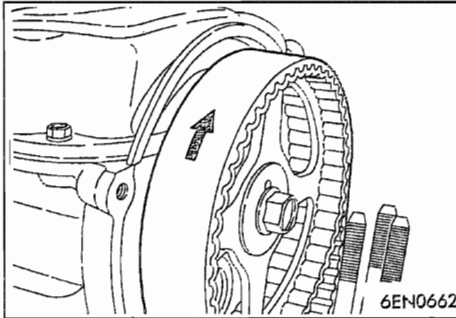

### REMOVAL SERVICE POINTS

#### <<A>> TIMING BELT REMOVAL

1. Mark the belt running direction for reinstallation.

##### NOTE:

(1) Water or oil on the belt shortens its life drastically, so the removed timing belt, sprocket, and tensioner must be washed or immersed in solvent. Replace parts if contaminated.

(2) If there is oil or water on any part, check the front case oil seals, camshaft oil seal, and water pump for leaks.

2. Loosen the tensioner pulley bolt, and then remove the timing belt.

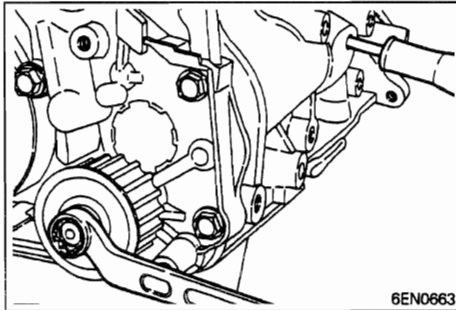

#### <<B>> OIL PUMP SPROCKET REMOVAL

1. Remove the plug on the left side of the cylinder block.
2. Insert a Phillips screwdriver (shank diameter 8 mm) through the plug hole to block the left counterbalance shaft.
3. Loosen the nut, and then remove the oil pump sprocket.

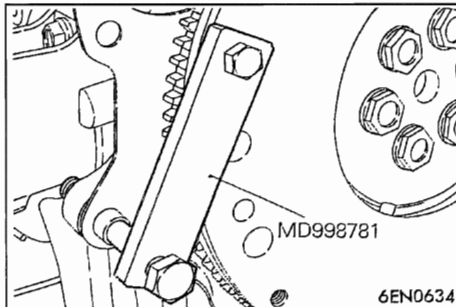

#### <<C>> CRANKSHAFT BOLT LOOSENING

1. Removal the crankshaft bolt and washer.

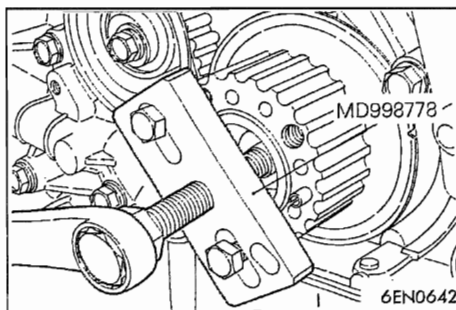

#### <<D>> CRANKSHAFT SPROCKET REMOVAL

1. Set special tool Crankshaft sprocket puller (MD998778) as shown in the illustration.
2. Screw in the center bolt of the special tool to remove the crankshaft sprocket.

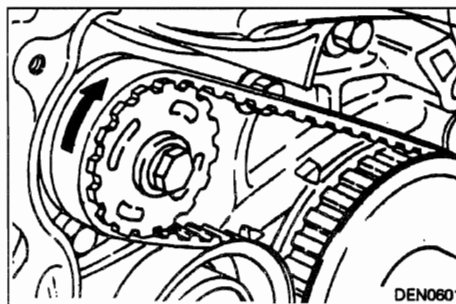

#### <<E>> TIMING BELT "B" REMOVAL

1. Mark the belt running direction for reinstallation.

##### NOTE:

Water or oil on the belt shortens its life drastically, so the removed timing belt, sprocket, and tensioner must be free from oil and water. These parts should not be washed or immersed in solvent. Replace parts if contaminated.



## TIME BELT

If there is oil or water on each part, check the front case oil seals, camshaft oil seal and water pump for leaks.

2. Loosen the tensioner "B" bolt, and then remove the timing belt "B."

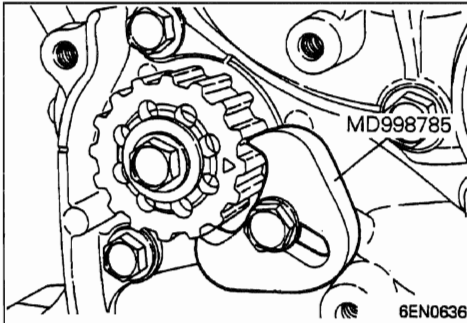

### <<F>> COUNTERBALANCE SHAFT SPROCKET REMOVAL

1. Set special tool Sprocket stopper (MD998785) as shown to prevent the counterbalance shaft sprocket from turning together.
2. Loosen the bolt and remove the sprocket.

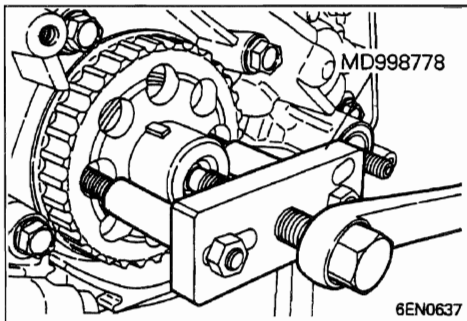

### <<G>> CRANKSHAFT SPROCKET "B" REMOVAL

1. Set special tool Crankshaft sprocket puller (MD998778) as shown in the illustration.
2. Screw in the center bolt of the special tool to remove crankshaft sprocket "B."

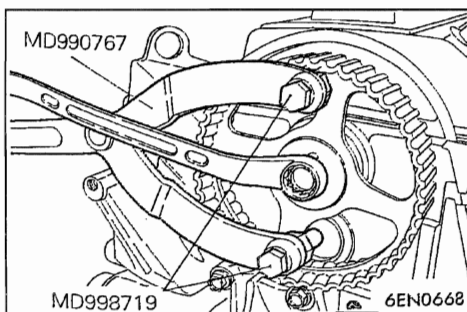

### <<H>> CAMSHAFT SPROCKET REMOVAL

1. Using special tools to prevent the camshaft sprocket from rotating.
2. Remove the camshaft sprocket.

## TIME BELT

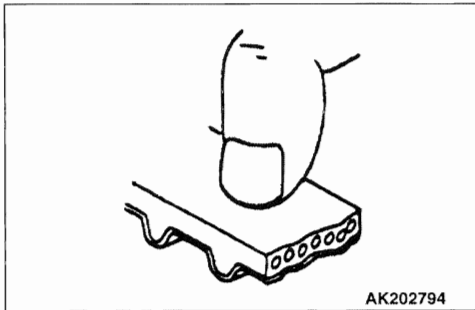

### INSPECTION

#### TIMING BELT

Replace the belt if any of the following conditions exist:

1. Hardening of rubber backing.

Back side should be glossy without resilience and leave no indent when pressed with fingernail.

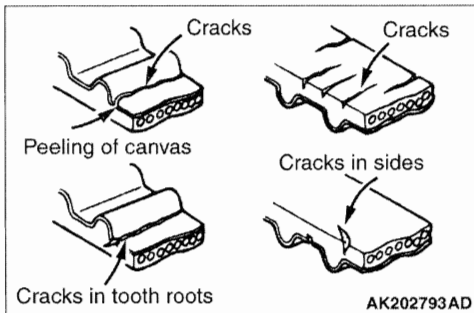

2. Cracks on rubber back.
3. Cracks or peeling of canvas.
4. Cracks at bottom of ribs.
5. Cracks on belt sides.

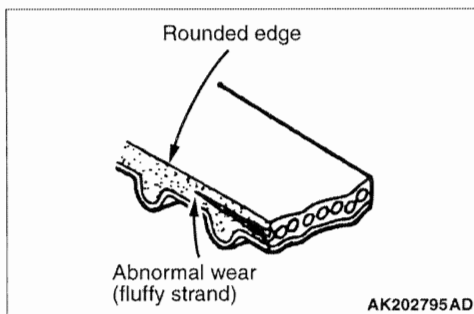

6. Abnormal wear of belt sides. Normal wear is indicated if the sides are sharp as if cut by a knife. Abnormal wear is indicated if the sides are ragged.

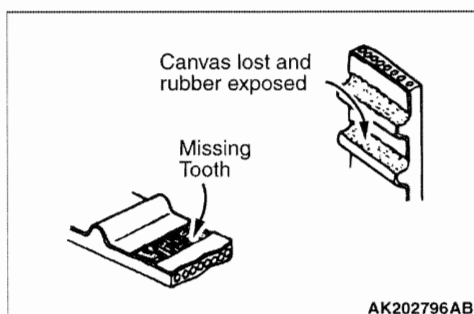

7. Abnormal wear on teeth.

#### Initial stage:

**Canvas worn (fluffy canvas fibers, rubbery texture gone, white discoloration, canvas texture indistinct)**

#### Final stage:

**Canvas worn, exposing rubber (tooth width reduced)**

8. Missing tooth.

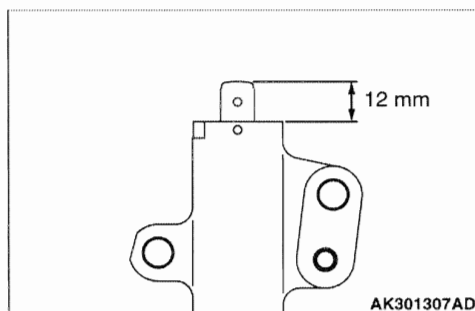

#### AUTO TENSIONER

1. Check for oil leaks. If oil leaks are evident, replace the auto-tensioner.
2. Check the rod end for wear or damage and replace the auto-tensioner if necessary.
3. Measure the rod protrusion. If it is out of specification, replace the auto-tensioner.

**Standard value: 12 mm**

## TIME BELT

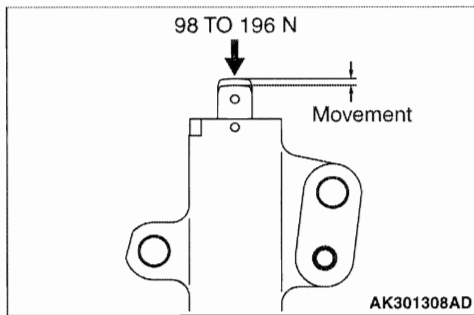

4. Press the rod with a force of 98 to 196 N and measure the movement of the rod.

If the measured value is out of the standard value, replace the auto-tensioner.

**Standard value: 1.0 mm or less**

## INSTALLATION SERVICE POINTS

### >>A<< CAMSHAFT SPROCKET INSTALLATION

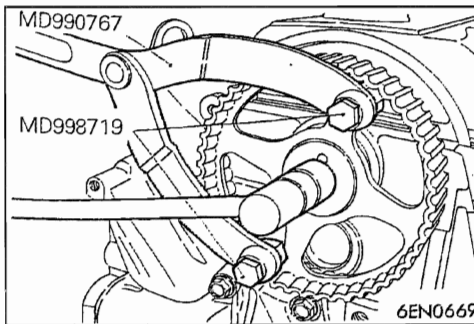

1. Using special tools to prevent the camshaft sprocket from rotating.

- End yoke holder (MB990767)
- Pulley holder pin (MD998719)

2. Tighten the camshaft sprocket bolt to the specified torque.

**Tightening torque: 88 ± 10 N·m**

### >>B<< SPACER INSTALLATION

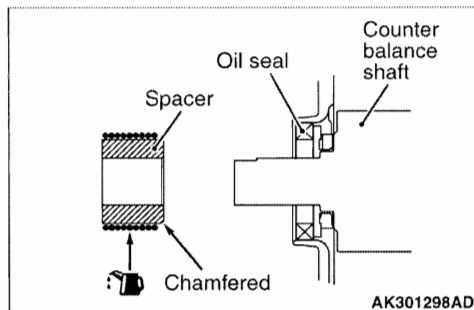

1. Apply a thin coat of clean engine oil to the lip area of the oil seal.

2. Install the spacer with the chamfered end facing toward the oil seal.

### >>C<< COUNTERBALANCE SHAFT SPROCKET INSTALLATION

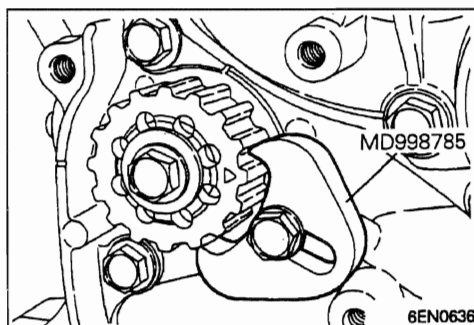

1. Install the counterbalance shaft sprocket and screw on the bolt.

2. Install special tool Sprocket stopper (MD998785) as shown in the illustration to lock the counterbalance shaft.

3. Tighten the bolt, and then remove the special tool.

**Tightening torque: 45 ± 3 N·m**

### >>D<< TIMING BELT "B" INSTALLATION

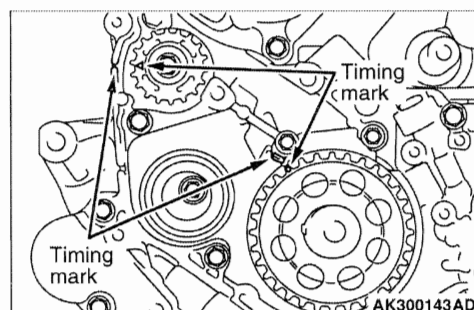

1. Align timing marks on the crankshaft sprocket "B" and counterbalance shaft sprocket with the marks on the front case.

2. Install the timing belt "B" on the crankshaft sprocket "B" and counterbalance shaft sprocket. There should be no slack on the tension side.

## TIME BELT

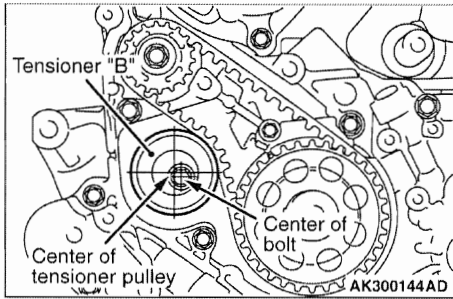

3. Make sure that the tensioner pulley center and the bolt center are positioned as shown in the illustration.

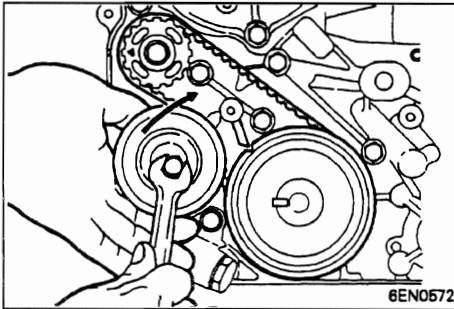

4. Move tensioner "B" in the direction of the arrow while lifting with your finger to give sufficient tension to the tension side of timing belt. In this condition, tighten the bolt to secure tensioner "B." When the bolt is tightened, use care to prevent the tensioner pulley shaft from turning with the bolt. If the shaft is turned with the bolt, the belt will be over tensioned.

**Tightening torque:  $19 \pm 3 \text{ N}\cdot\text{m}$**

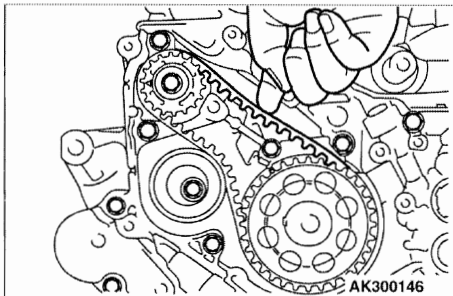

5. Check that timing marks on the sprockets are aligned with the timing marks on the front case.
6. With your index finger, press the midway of span on the tension side of timing belt "B." The bolt must deflect 5 to 7 mm.

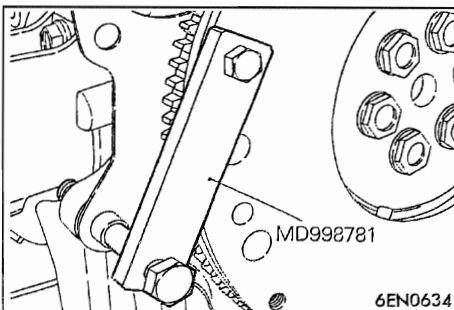

### >>E<< CRANKSHAFT BOLT INSTALLATION

1. Tighten the crankshaft bolt to the specified torque.

**Tightening torque:  $162\text{N}\cdot\text{m}$**

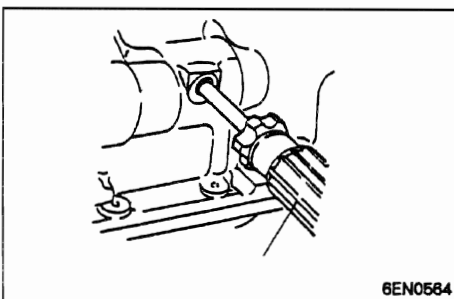

### >>F<< OIL PUMP SPROCKET INSTALLATION

1. Insert a Phillips head screwdriver (shank diameter 8 mm) through the plug hole on the left side of the cylinder block to block the left counterbalance shaft.
2. Install the oil pump sprocket.
3. Apply a thin coat of engine oil to the seating surface of the nut.
4. Tighten the nut to the specified torque.

**Tightening torque:  $54 \pm 5 \text{ N}\cdot\text{m}$**

## TIME BELT

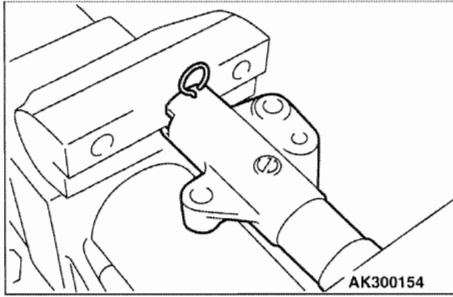

### >>G<< AUTO-TENSIONER INSTALLATION

If the auto-tensioner rod is fully extended, reset it as follows:

1. Clamp the auto-tensioner in a vise with soft jaws.

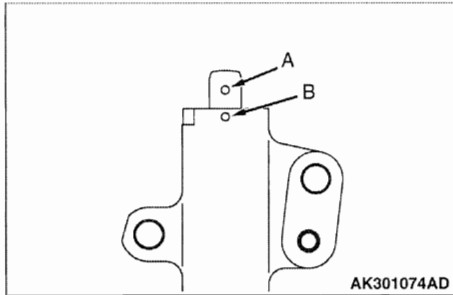

2. Push in the rod little by little with the vise until the set hole A in the rod is aligned with hole B in the cylinder.

3. Insert a wire (1.4 mm in diameter) into the set holes. This auto-tensioner setting wire will be used during timing belt alignment.

4. Unclamp the auto-tensioner from the vise.

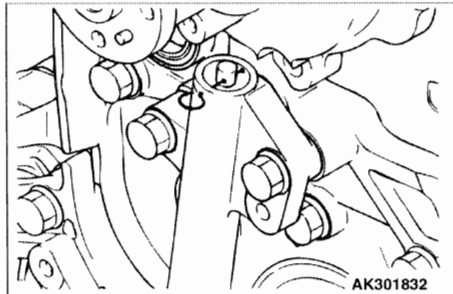

5. Install the auto-tensioner onto the front case and tighten to the specified torque.

#### **Note:**

Leave the wire installed in the auto-tensioner.

**Tightening torque:  $24 \pm 3$  N·m**

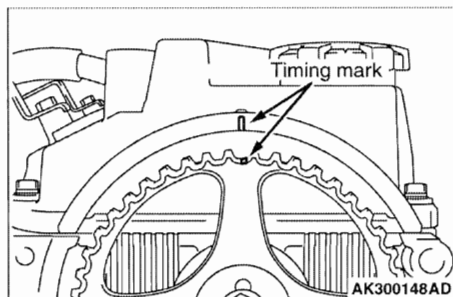

### >>H<< TIMING BELT INSTALLATION

1. Align the timing mark on the camshaft sprocket with the timing mark on the rocker cover.

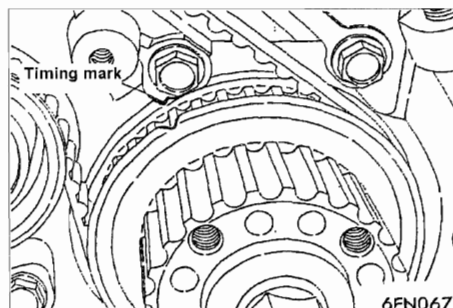

2. Align the timing mark on the crankshaft sprocket with the timing mark on the front case.

## TIME BELT

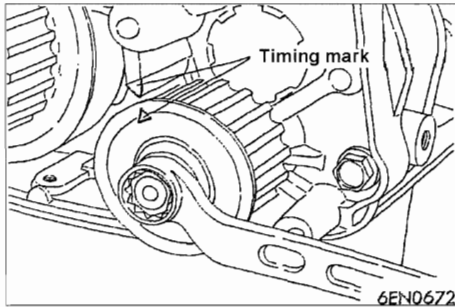

3. Align the timing mark on oil pump sprocket with its mating mark.

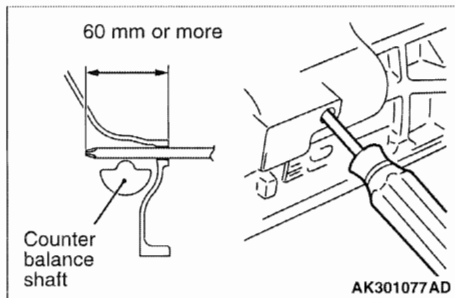

4. Remove the plug on the cylinder block and insert a Phillips head screwdriver (shank diameter 8 mm) through the hole.

If it can be inserted as deep as 60 mm or more, the timing marks are correctly aligned.

If the inserted depth is only 20 to 25 mm, turn the oil pump sprocket one turn and realign the timing marks. Then check to ensure that the screwdriver can be inserted 60 mm or more. Keep the screwdriver inserted until the timing belt is completely installed.

5. Install the timing belt on the crankshaft sprocket, oil pump sprocket, idler pulley, camshaft sprocket, and tensioner pulley in that order.

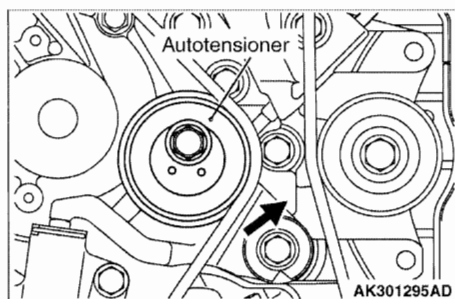

6. Lift up the tensioner pulley in the direction of the arrow and tighten the center bolt.

7. Check that all timing marks are aligned.

8. Remove the screwdriver inserted in step 4 and install the plug.

9. Turn the crankshaft a quarter turn counterclockwise. Then, turn it clockwise until the timing marks are aligned again.

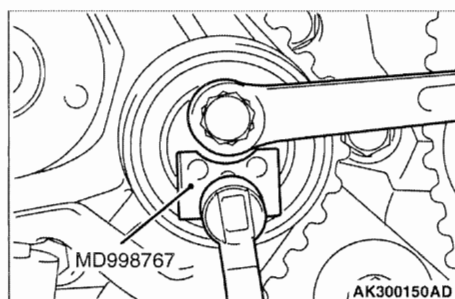

10. Install special tool Tension pulley socket wrench (MD998767), socket wrench and torque wrench, onto the tensioner pulley, and loosen the tensioner pulley center bolt.

### NOTE:

Use a torque wrench that can measure 0 to 5.0 N·m.

11. Torque to 2.5-2.6 N·m with the torque wrench.

12. Holding the tensioner pulley with special tool Tension pulley socket wrench (MD998767) and torque wrench, tighten the center bolt to specification.

**Tightening torque: 48 ± 5 N·m**

## TIME BELT

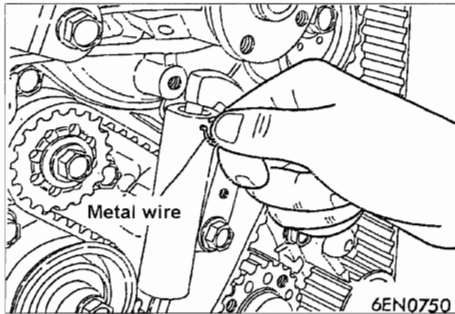

13. The wire inserted at the auto-tensioner installation is pulled out and then the special tool Set screw (MD998738) is removed by hand.
14. Give two clockwise turns to the crankshaft. Wait for 15 minutes, then proceed with the following inspection steps.

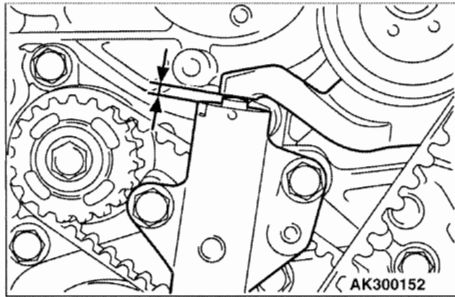

15. Check to see whether the metal wire (inserted when the auto-tensioner was installed) can be removed without any resistance. If the metal wire can be removed without any resistance, it means that the belt has a proper tension. Therefore, remove the metal wire. In this condition, check that the rod protrusion of the auto-tensioner is within the standard value.

**Standard value: 3.8 - 4.5 mm**

16. If the metal wire offers resistance when removed, repeat the previous steps 9 through 14 until the standard value is obtained as measured by the rod projection of the auto-tensioner rod.

# WATER PUMP

## REMOVAL AND INSTALLATION

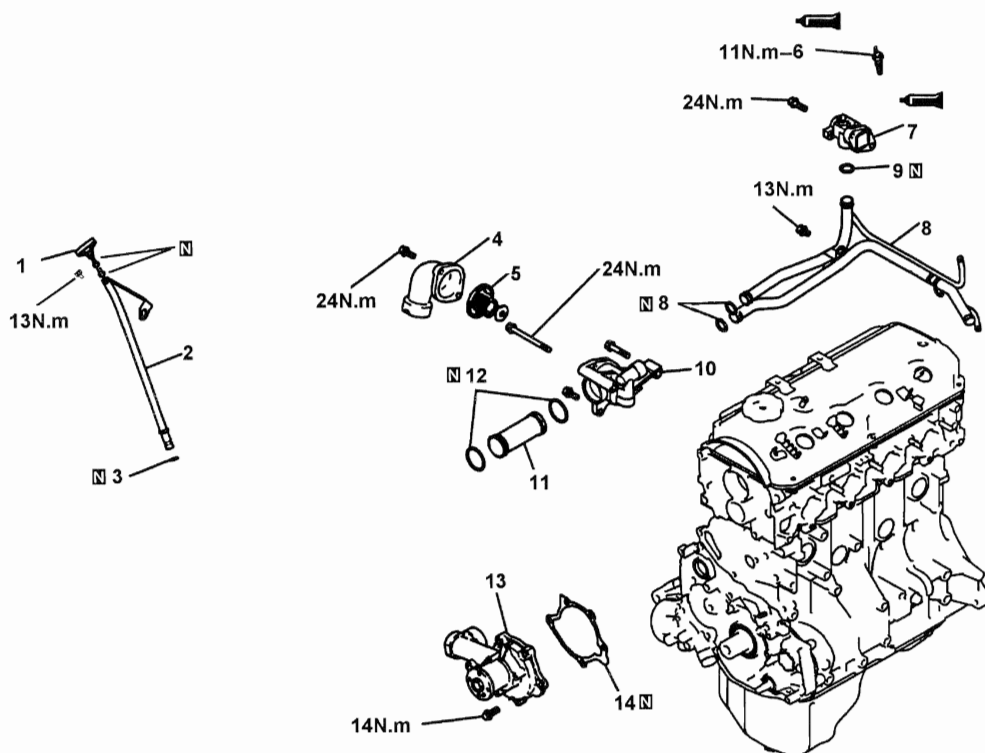

### Removal steps

- |  |                            |
|--|----------------------------|
| 1. Oil level gauge                       | >>A<< 8. Water inlet pipe  |
| 2. Oil level gauge guide                 | >>A<< 9. O-ring            |
| 3. O-ring                                | 10. Thermostat housing     |
| 4. Water inlet fitting                   | >>A<< 11. Water inlet pipe |
| >>C<< 5. Thermostat                      | >>A<< 12. O-ring           |
| 6. Engine coolant temperature gauge unit | 13. Water pump             |
| >>B<< 7. Water outlet fitting            | 14. Water pump gasket      |



## WATER PUMP

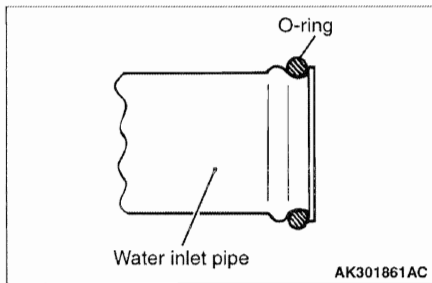

### INSTALLATION SERVICE POINTS

#### >>A<< WATER INLET PIPE/O-RING

##### INSTALLATION

1. Attach a new O-ring to each end of the water inlet pipe.
2. Wet the O-ring with water.

**Note:** Keep the O-ring free of oil or grease.

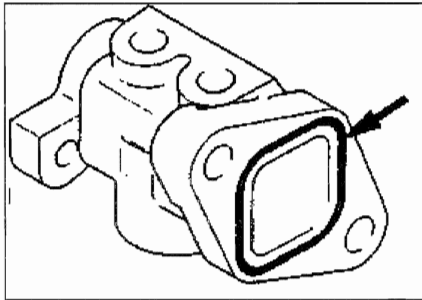

#### >>B<< WATER OUTLET FITTING INSTALLATION

1. Apply a 3 mm diameter bead of FIPG to the indicated surface of the water outlet fitting.

**Specified sealant:**

**Mitsubishi Genuine Part No.MD970389 or equivalent**

2. Install the housing quickly (within 15 minutes) while the sealant is wet and tighten the bolts to the specified torque.

**Note:**

After installation, keep the sealed area away from the coolant for approximately one hour.

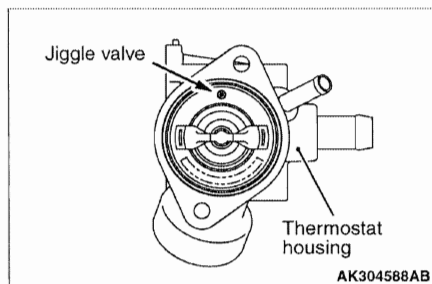

#### >>C<< THERMOSTAT INSTALLATION

1. Check that the rubber ring is undamaged and seated correctly in the thermostat flange.
2. Install the thermostat as shown in the illustration. The jiggle valve must be at the uppermost position.

## ROCKER ARMS AND CAMSHAFT

### ROCKER ARMS AND CAMSHAFT

#### REMOVAL AND INSTALLATION

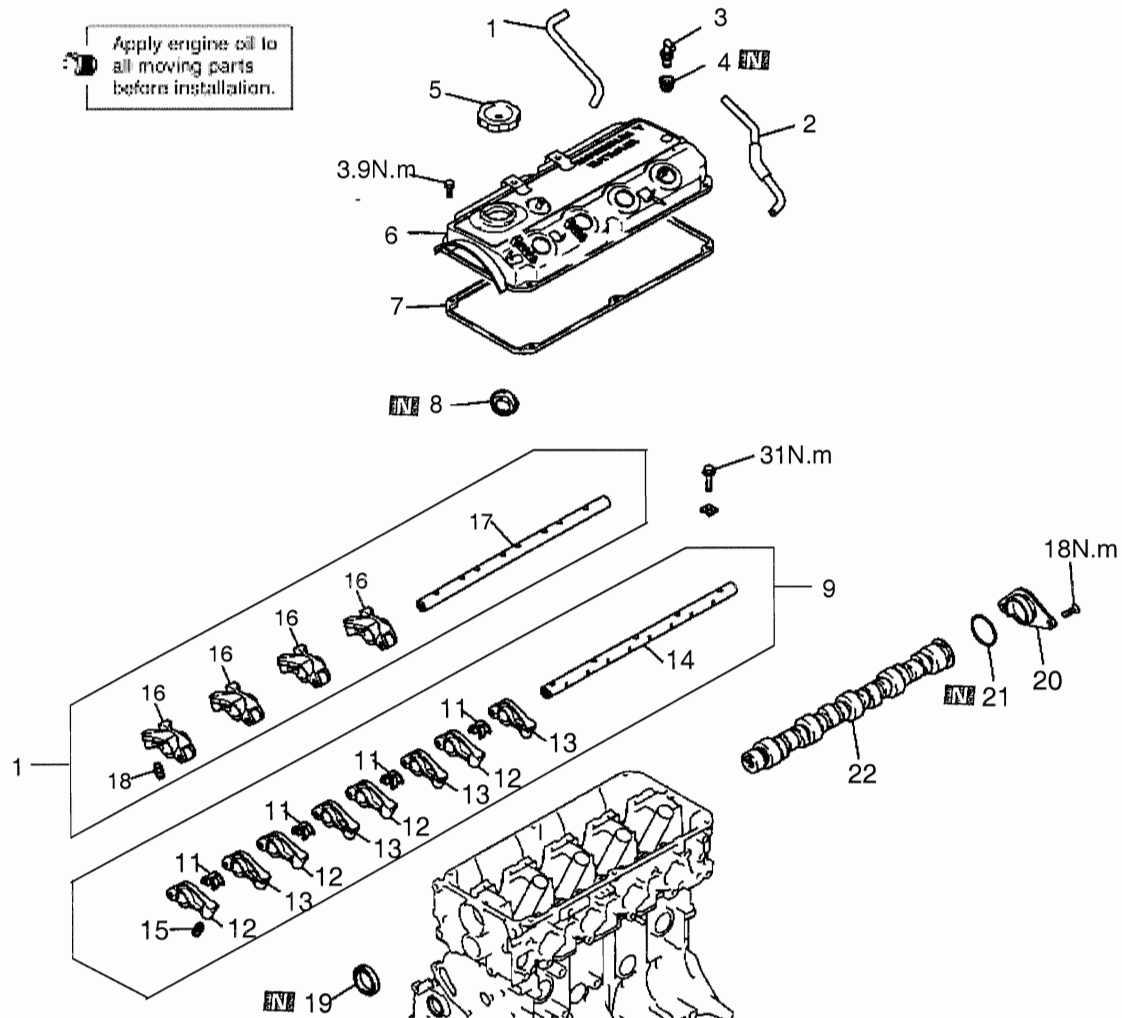

6EN1762

#### Removal steps

- |  |                                     |
|--|-------------------------------------|
| 1. Breather hose                                 | 12. Rocker arm "A"                  |
| 2. PCV hose                                      | 13. Rocker arm "B"                  |
| 3. PCV valve                                     | 14. Rocker arm shaft (Intake side)  |
| 4. PCV valve gasket                              | >>B<< 15. Lash adjuster             |
| 5. Oil filler cap                                | 16. Rocker arm "C"                  |
| 6. Rocker cover                                  | 17. Rocker arm shaft (Exhaust side) |
| 7. Rocker cover gasket                           | >>B<< 18. Lash adjuster             |
| 8. Oil seal                                      | >>A<< 19. Oil seal                  |
| <<A>> >>C<< 9. Rocker arms and rocker arm shaft  | 20. Thrust case                     |
| <<A>> >>C<< 10. Rocker arms and rocker arm shaft | 21. O-ring                          |
| >>C<< 11. Rocker arm shaft ring                  | 22. Camshaft                        |

## ROCKER ARMS AND CAMSHAFT

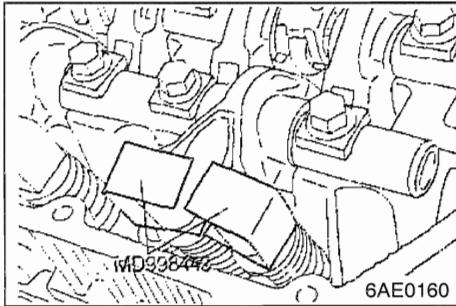

### REMOVAL SERVICE POINT

#### <<A>> ROCKER ARMS AND ROCKER ARM SHAFT REMOVAL

1. Before removing rocker arms and shafts assembly, install the special tool as illustrated prevent the adjusters from dropping.

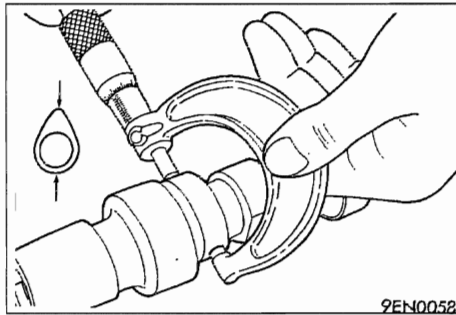

### INSPECTION

#### CAMSHAFT

Measure the cam height. If it is below the limit, replace the camshaft.

	Standard value	Minimum limit
Intake	37.39mm	36.89mm
Exhaust	36.83mm	36.33mm

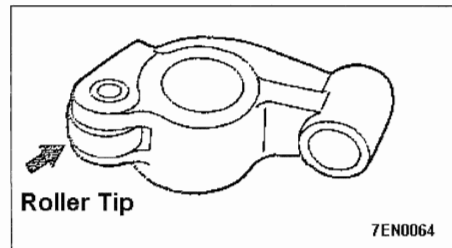

#### ROCKER ARM

1. Check the roller or slipper surface. If any dents, damage or seizure is evident, replace the rocker arm.
2. Check the roller for smooth rotation. If it does not rotate smoothly or if looseness is evident, replace the rocker arm.
3. Check the inside diameter. If damage or seizure is evident, replace the rocker arm.

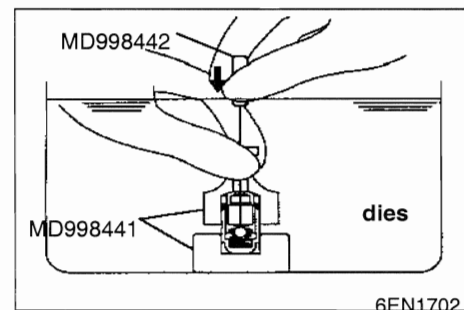

#### LASH ADJUSTER LEAK DOWN TEST

##### NOTE:

- ⊙ The lash adjuster is a precision part. Keep it free from dust and other foreign matter.
- ⊙ Do not disassemble lash adjusters.
- ⊙ When cleaning lash adjusters, use clean diesel fuel only.

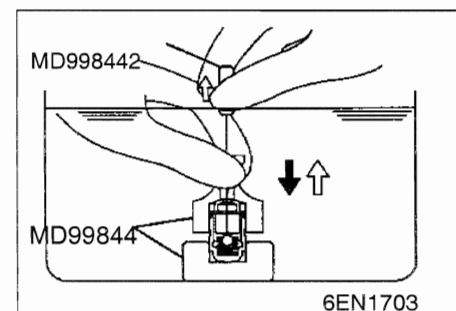

1. Immerse the lash adjuster in clean diesel fuel.
2. While lightly pushing down the inner steel ball using the special tool, Air Bleed Wire, move the plunger up and down four or five times to bleed air. Use of the retainer (special tool) helps facilitate the air bleeding of the rocker arm mounted type lash adjuster.

## ROCKER ARMS AND CAMSHAFT

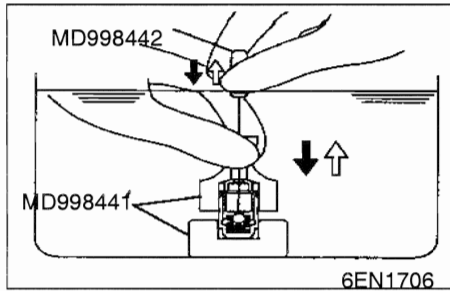

- Remove the wire and press the plunger. If the plunger is hard to be pushed in, the lash adjuster is normal. If the plunger can be pushed in all the way readily, bleed the lash adjuster again and test again. If the plunger is still loose, replace the lash adjuster.

### NOTE:

- Upon completion of air bleeding, hold the lash adjuster upright to prevent inside diesel fuel from spilling.

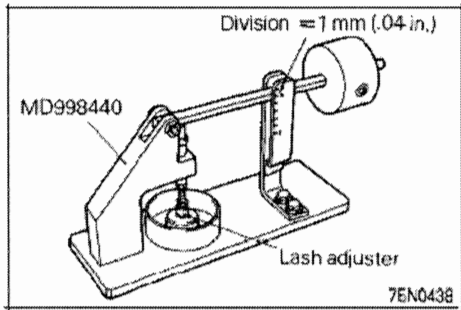

- After air bleeding, set the lash adjuster on the special tool (Leak down tester MD998440).
- After the plunger has gone down somewhat (0.2-0.5 mm), the measured time is out of the specification.

### Standard value:

**4-20 secinds/1 mm (Diesel fuel at 15-20°C)**

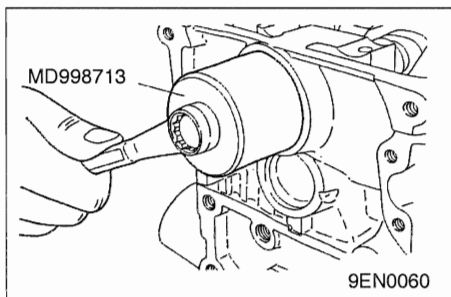

## INSTALLATION SERVICE POINTS

### >>A<< CAMSHAFT SEAL INSTALLATION

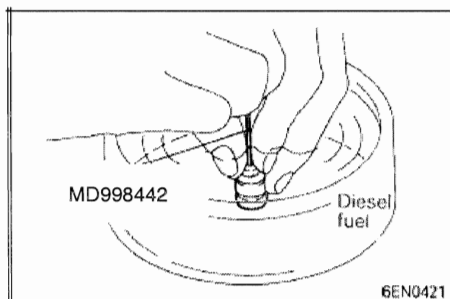

### >>B<< LASH ADJUSTER INSTALLATION

- Immerse the lash adjuster in clean diesel fuel.
- Using the special tool ( air bleed wire ), move the plunger up and down 4 or 5 times while pushing down lightly on the check ball in order to bleed out the air.

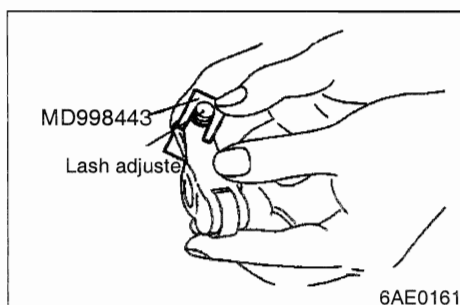

- Insert the lash adjuster to the rocker arm, being careful not to spill the diesel fuel. Then use the special tool to prevent the adjuster from falling while installing it.

## ROCKER ARMS AND CAMSHAFT

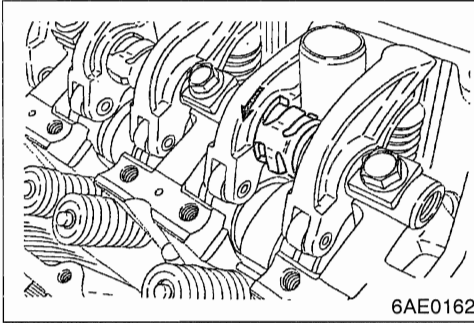

### >>C<< ROCKER SHAFT SPRING, ROCKER ARM AND ROCKER SHAFT INSTALLATION

1. Temporarily tighten the rocker shaft on the inlet valve side with bolt so that all rocker arms do not push the valves.
2. Fit the rocker shaft spring from the above and position it so that it is right angles the spark plug guide.

**NOTE:**

Install the rocker shaft springs before installation of the exhaust side rocker arms and shaft.

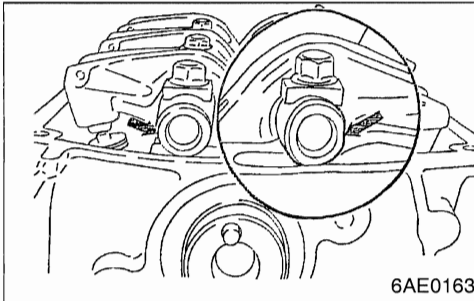

3. Remove the special tool used to hold the lash adjuster.
4. Make sure that the notch in the rocker shaft is directed as shown in the illustration.

## CYLINDER HEAD AND VALVES

### CYLINDER HEAD, VALVES

#### REMOVAL AND INSTALLATION

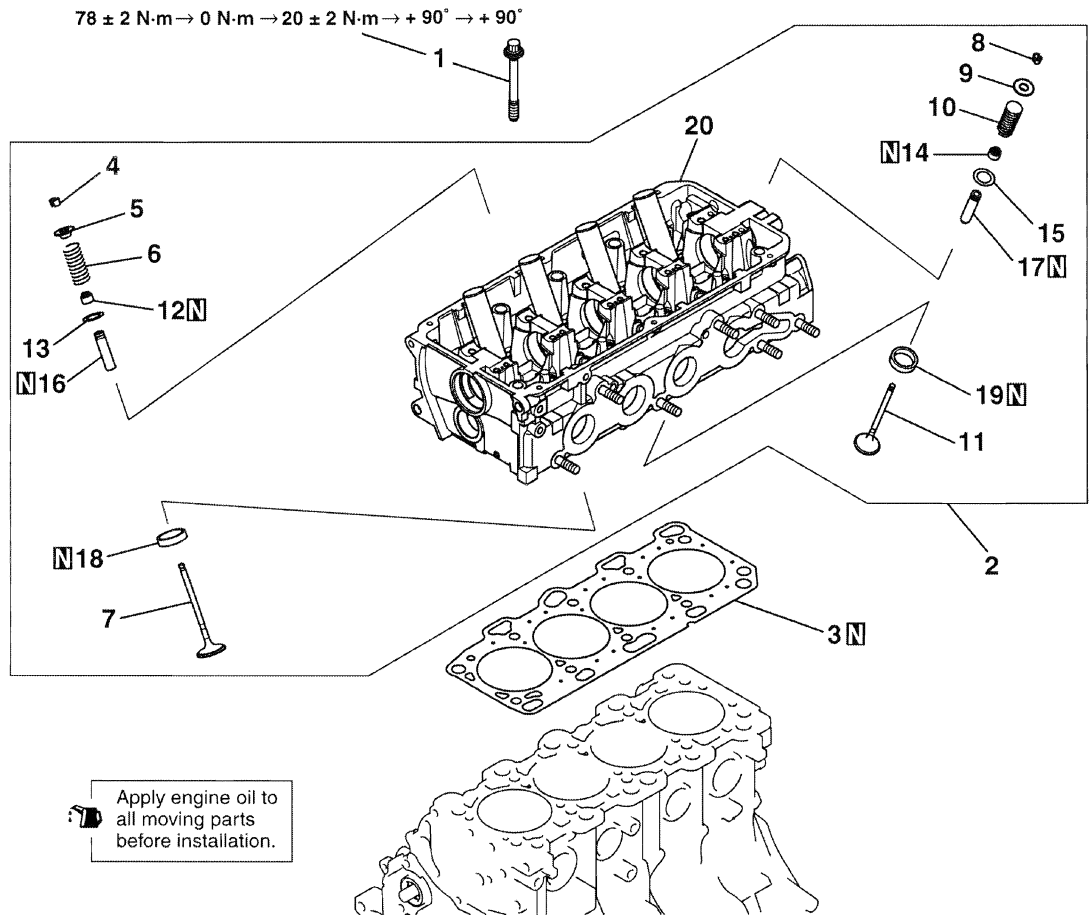

AK301262AE

#### Removal steps

- |       |       |                           |                         |
|-------|-------|---------------------------|-------------------------|
| <<A>> | >>D<< | 1. Cylinder head bolt     | 11. Exhaust valve       |
|       |       | 2. Cylinder head assembly | <<C>> >>A<<             |
|       |       | 3. Cylinder head gasket   | 12. Valve stem seal     |
| <<B>> | >>C<< | 4. Retainer lock          | 13. Valve spring seat   |
|       |       | 5. Valve spring retainer  | <<C>> >>A<<             |
|       | >>B<< | 6. Valve spring           | 14. Valve stem seal     |
|       |       | 7. Intake valve           | 15. Valve spring seat   |
| <<B>> | >>C<< | 8. Retainer lock          | 16. Intake valve guide  |
|       |       | 9. Valve spring retainer  | 17. Exhaust valve guide |
|       | >>B<< | 10. Valve spring          | 18. Intake valve seat   |
|       |       |                           | 19. Exhaust valve seat  |
|       |       |                           | 20. Cylinder head       |

## CYLINDER HEAD AND VALVES

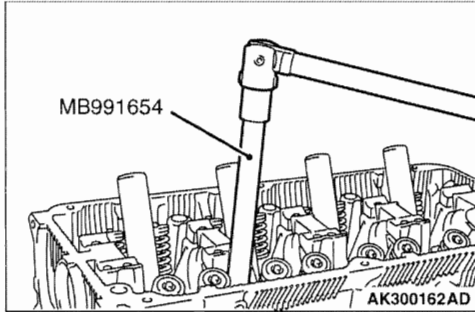

### REMOVAL SERVICE POINTS

#### <<A>> CYLINDER HEAD BOLTS REMOVAL

Using special tool Cylinder head bolt wrench (MB991654), loosen the cylinder head bolts. Loosen each bolt evenly, little by little, by two or three steps.

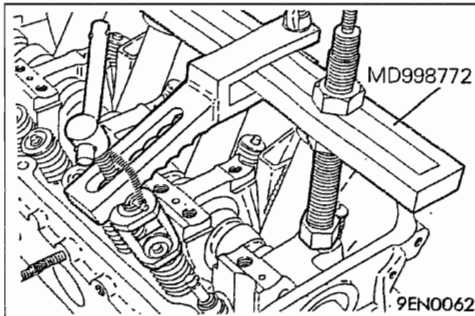

#### <<B>> RETAINER LOCK REMOVAL

1. Set special tool Valve spring compressor (MD998772) as illustrated to compress the valve spring. Remove the retainer lock.
2. Relieve the spring tension and remove the valve, retainer, spring, etc. Store removed valves, springs, and other parts, tagged to indicate their cylinder number and location for assembly.

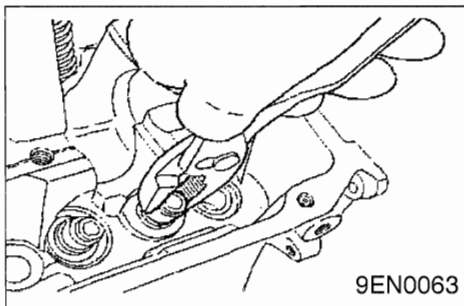

#### <<C>> VALVE STEM SEAL REMOVAL

1. Do not reuse removed valve stem seal.

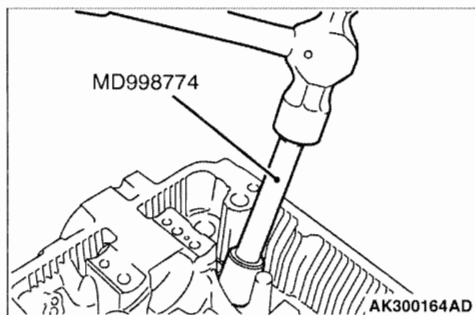

### INSTALLATION SERVICE POINTS

#### >>A<< VALVE STEM SEAL INSTALLATION

1. Install the valve spring seat.
2. Using special tool Valve stem seal installer (MD998774), install a new valve stem seal.

#### NOTE:

The special tool must be used to install the valve Stem seal. Improper installation could result in oil leaking past the valve guide.

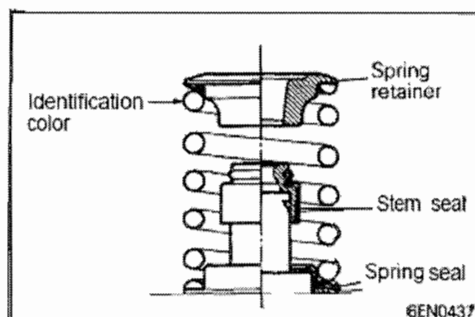

#### >>B<< VALVE SPRING INSTALLATION

Install the valve spring with its identification color painted end (larger pitch side) upward (toward the valve spring retainer).

#### Identification:

- <Intake> Light blue
- <Exhaust> Orange

## CYLINDER HEAD AND VALVES

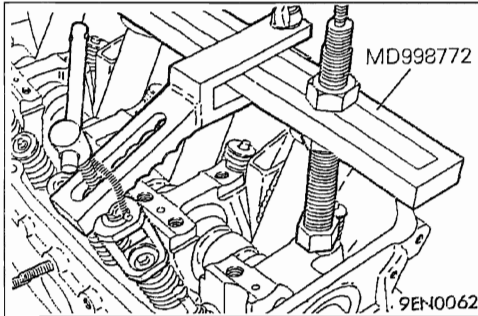

### >>C<< RETAINER LOCK INSTALLATION

1. The valve spring, if excessively compressed, causes the bottom end of the retainer to be in contact with, and damage, the stem seal.

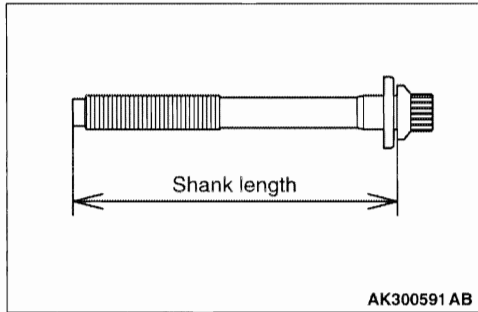

### >>D<< CYLINDER HEAD BOLT INSTALLATION

1. When the removed cylinder head bolts are to be reused, check that the shank length of each bolt meets the limit. If it exceeds the limit, replace the bolts.

**Limit: 99.4 mm**

2. Apply engine oil to the thread of the bolts and to the washers.

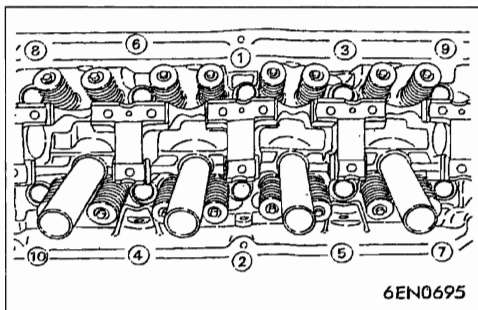

3. Using special tool Cylinder head bolt wrench (MB991654) tighten the bolts to the specified torque, using the tightening sequence shown.

**Tightening torque: 78 ± 2 N·m**

4. Loosen all bolts fully in the reverse order of tightening.
5. Retighten the loosened bolts to in the tightening sequence shown.

**Tightening torque: 20 ± 2 N·m**

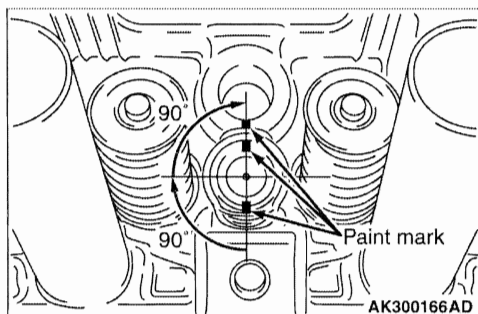

6. Make a paint mark across each bolt head and cylinder head.
7. Tighten the cylinder head bolts 90 degrees in the specified order.
8. Tighten the bolts another 90 degrees in the same order as in step 7, and check that the paint marks on the cylinder head bolt are aligned with the paint marks on the cylinder head.

### NOTE:

- If the bolt is turned less than 90 degrees, proper fastening performance may not be achieved. Be careful to turn each bolt exactly 90 degrees.
- If the bolt is overtightened, loosen the bolt completely and then retighten it by repeating the tightening procedure from step 1.



## CYLINDER HEAD AND VALVES

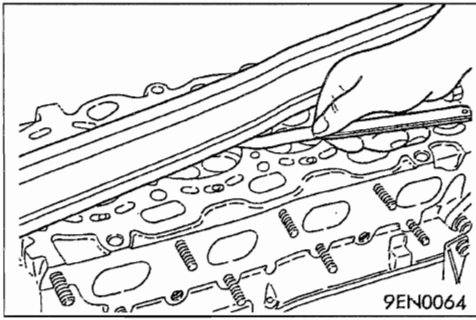

### INSPECTION

#### CYLINDER HEAD

1. Check the cylinder head gasket surface for flatness by using a straight edge and feeler gauge.

**Standard value: 0.03 mm**

**Limit: 0.2 mm**

2. If it exceeds the limit, correct to meet specification.

**Grinding limit: \*0.2 mm**

\*Includes combined with cylinder block grinding.

Cylinder head height (Specification when new):

**119.9-120.1 mm**

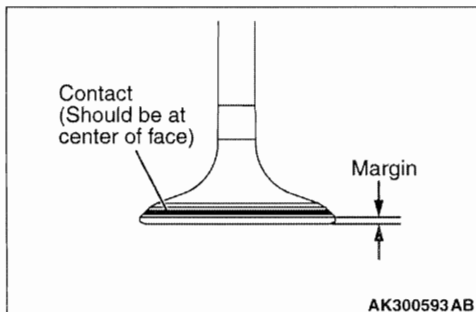

#### VALVE

1. Check the valve seat contact. Valve seat contact should be uniform at the center of the valve face. If incorrect, reface using a valve refacer.

2. If the margin is below the limit, replace the valve.

**Standard value:**

**<Intake> 1.0 mm**

**<Exhaust> 1.2 mm**

**Minimum limit:**

**<Intake> 0.5 mm**

**<Exhaust> 0.7mm**

3. Measure the valve's total length. If the measurement is less than the limit, replace the valve.

**Standard value:**

**<Intake> 112.30 mm**

**<Exhaust> 114.11 mm**

**Minimum limit:**

**<Intake>111.80 mm**

**<Exhaust> 113.61 mm**

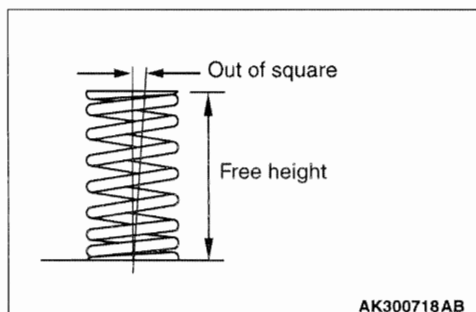

#### VALVE SPRING

1. Measure the free height of the spring. If it is less than the limit, replace.

**Standard value: 51.0 mm**

**Minimum limit : 50.0 mm**

2. Measure the squareness of the spring. If it exceeds the limit, replace.

**Standard value:**

**2 degrees or less**

**Limit: 4 degrees**

## CYLINDER HEAD AND VALVES

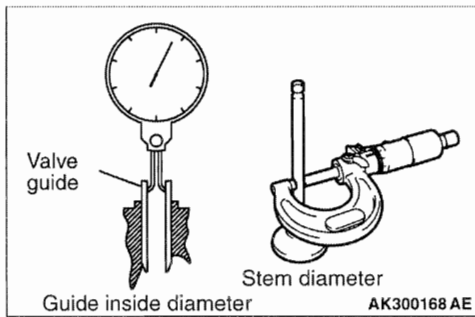

### VALVE GUIDE

Measure the clearance between the valve guide and valve stem. If it exceeds the limit, replace the valve guide or valve, or both.

**Standard value:**

<Intake> 0.02 - 0.05 mm

<Exhaust> 0.03 - 0.07 mm

**Limit:**

<Intake> 0.10 mm

<Exhaust> 0.15 mm

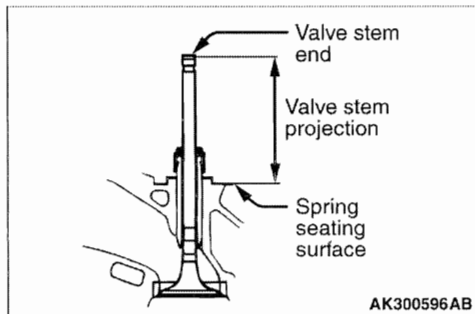

### VALVE SEAT

Assemble the valve, then measure the valve stem projection between the end of the valve stem and the spring seating surface. If the measurement exceeds the specified limit, replace the valve seat.

**Standard value:**

<Intake> 49.30 mm

<Exhaust> 49.30 mm

**Limit:**

<Intake> 49.80 mm

<Exhaust> 49.80 mm

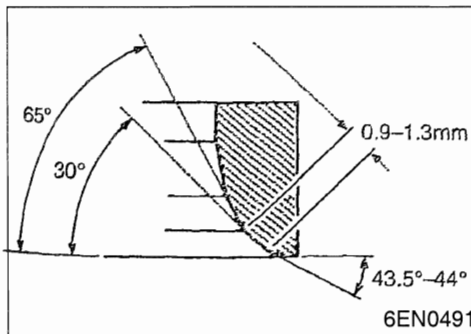

### VALVE SEAT RECONDITIONING PROCEDURE

1. Before correcting the valve seat, check for clearance between the valve guide and valve and, if necessary, replace the valve guide.
2. Using the seat grinder, correct to obtain the specified seat width and angle.
3. After correcting the valve seat, lap the valve and valve seat using lapping compound. Then, check the valve stem projection.

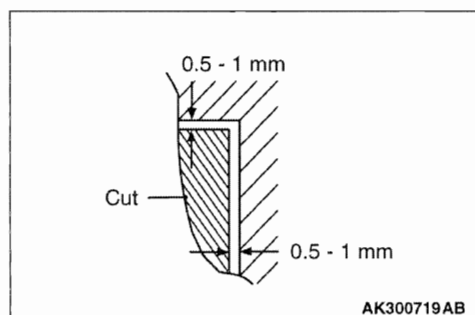

### VALVE SEAT REPLACEMENT PROCEDURE

1. Cut the valve seat from the inside to thin the wall thickness. Then, remove the valve seat.
2. Rebore the valve seat hole in the cylinder head to a selected oversize valve seat diameter.

**Intake seat ring hole diameters**

**0.3 oversize: 35.435 – 34.455 mm**

**0.6 oversize: 34.735 – 34.755 mm**

**Exhaust seat ring hole diameters**

**0.3 oversize: 31.935 – 31.955 mm**

## CYLINDER HEAD AND VALVES

**0.6 oversize: 32.235**

**- 2.255 mm**

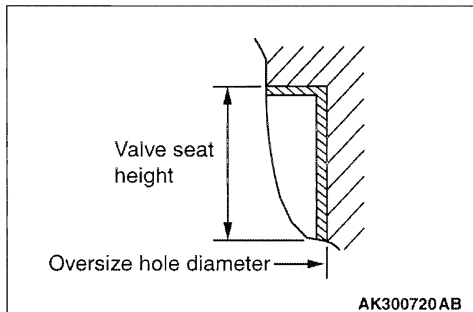

3. Before fitting the valve seat, either heat the cylinder head up to approximately 250°C or cool the valve seat in liquid nitrogen, to prevent the cylinder head bore from galling.
4. Using a valve seat cutter, correct the valve seat to the specified width and angle.  
See "VALVE SEAT RECONDITIONING PROCEDURE" on the previous page.

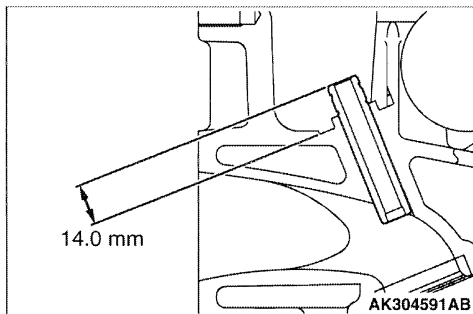

### VALVE GUIDE REPLACEMENT PROCEDURE

1. Using a press, remove the valve guide toward the cylinder block.
2. Rebore the valve guide hole of the cylinder head so that it fits the press-fitted oversize valve guide.

#### NOTE:

Do not install a valve guide of the same size again.

#### Valve guide hole diameters

**0.05 oversize 11.05 - 11.07 mm**

**0.25 oversize 11.25 - 11.27 mm**

**0.50 oversize 11.50 - 11.52 mm**

3. Press-fit the valve guide until it protrudes 14.0 mm from the cylinder head top surface as shown in the illustration.

#### NOTE:

When press-fitting the valve guide, work from the cylinder head top surface.

Pay attention to the difference in length of the valve guides.

**(Intake side: 45.5 mm; exhaust side: 50.5 mm)**

4. After installing the valve guides, insert new valves in them to check for smooth operation.

FRONT CASE, SILENT SHAFT AND OIL PAN

REMOVAL AND INSTALLATION

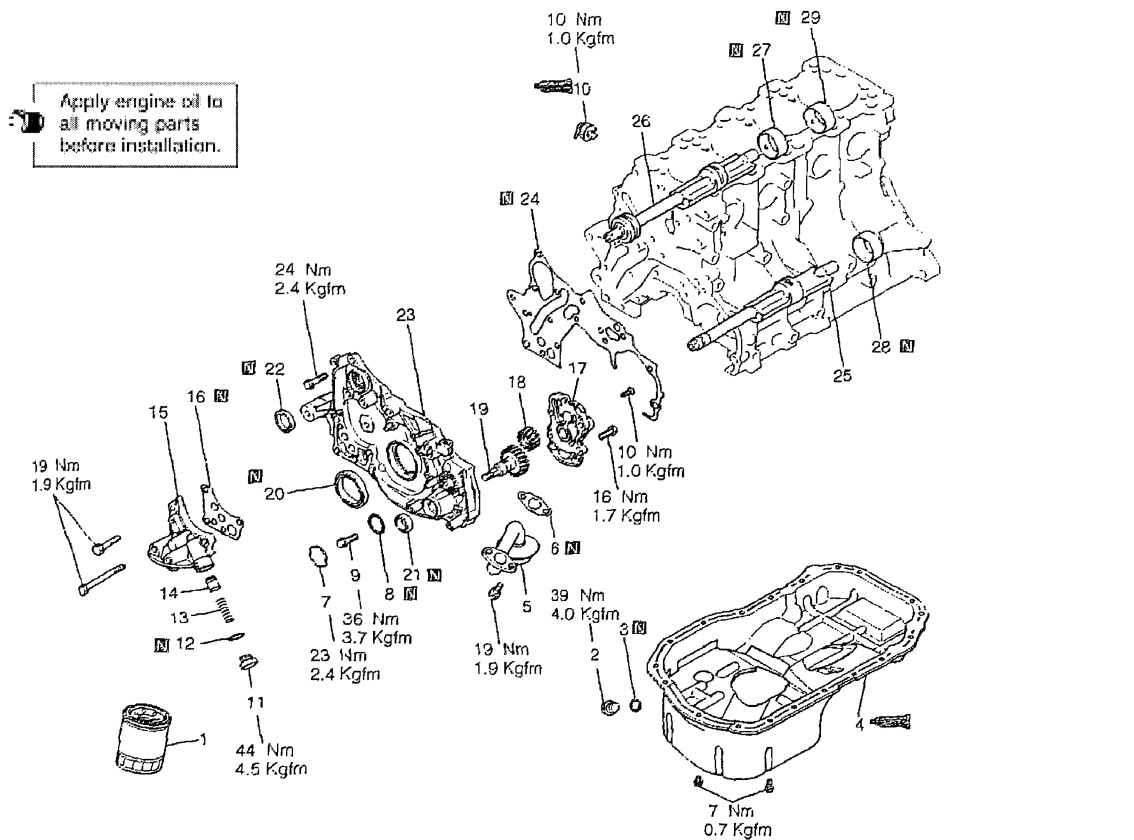

Removal steps

- |       |                               |   |
|-------|-------------------------------|---|
| >>N<< | 1. Oil filter                 | 17. Oil pump cover                          |
|       | 2. Drain plug                 | >>H<< 18. Oil pump driven gear              |
| >>M<< | 3. Drain plug gasket          | >>H<< 19. Oil pump drive gear               |
| <<A>> | >>L<< 4. Oil pan              | >>G<< 20. Crankshaft front oil              |
|       | 5. Oil screen                 | >>F<< 21. Oil pump oil seal                 |
|       | 6. Oil screen gasket          | >>E<< 22. Counterbalance shaft oil seal     |
| <<B>> | >>K<< 7. Plug                 | >>D<< 23. Front case                        |
|       | 8. O-ring                     | 24. Front case gasket                       |
| <<C>> | >>J<< 9. Flange bolt          | 25. Counterbalance shaft, left              |
|       | >>I<< 10. Oil pressure switch | 26. Counterbalance shaft, right             |
|       | 11. Relief plug               | <<D>> >>C<< 27. Counterbalance shaft, front |
|       | 12. Gasket                    | <<E>> >>B<< bearing, right                  |
|       | 13. Relief spring             | <<E>> >>A<< 28. Counterbalance shaft, rear  |
|       | 14. Relief plunger            | bearing, left                               |
|       | 15. Oil filter bracket        | 29. Counterbalance shaft,                   |
|       | 16. Oil filter bracket gasket | rear bearing, right                         |

## FRONT CASE, SILENT SHAFT AND OIL PAN

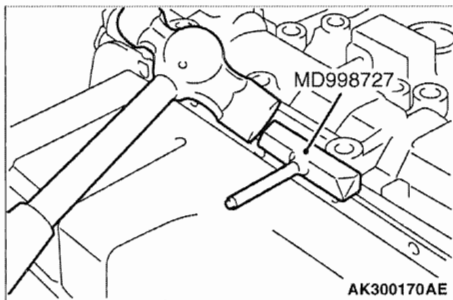

### REMOVAL SERVICE POINTS

#### <<A>> OIL PAN REMOVAL

1. Remove the oil pan bolts.
2. Insert the special tool Oil pan remover (MD998727) into the joint between the cylinder block and oil pan by tapping the tool with a hammer.
3. Remove the oil pan by tapping an edge of the special tool Oil pan remover (MD998727) with a hammer to move it sideways.

#### NOTE:

Never use a screwdriver or chisel, instead of the special tool, as a deformed oil pan flange will result, resulting in oil leakage.

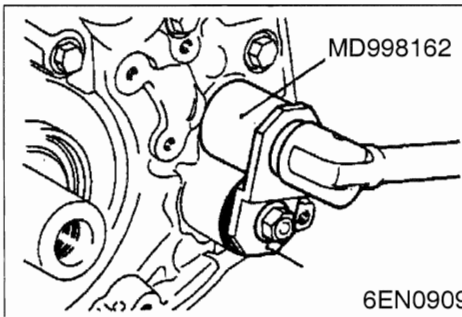

#### <<B>> PLUG REMOVAL

1. If the plug is too tight, hit the plug head with a hammer two to three times, and the plug will be easily loosened.

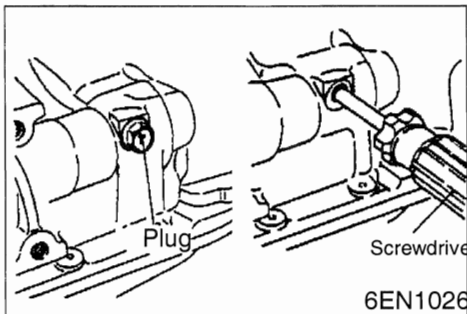

#### <<C>> FLANGE BOLT REMOVAL

1. Remove the plug on the side of the cylinder block.
2. Insert a Phillips screwdriver (shank diameter 8 mm) into the plug hole to lock the counterbalance shaft.

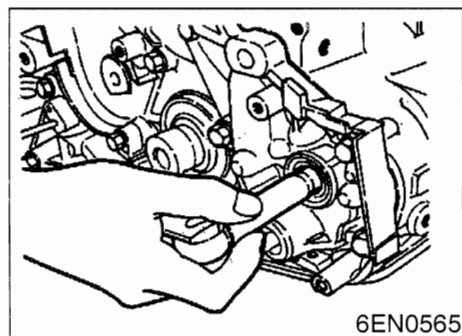

3. Loosen the flange bolt.

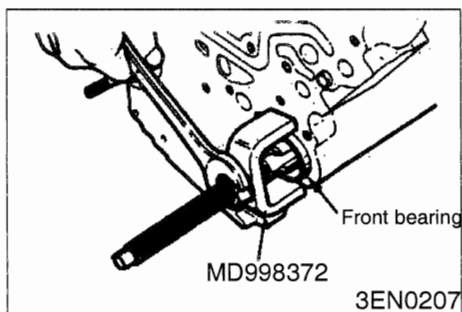

#### <<D>> RIGHT COUNTERBALANCE SHAFT FRONT BEARING REMOVAL

1. Using special tool Silent shaft bearing puller (MD998371), remove the counterbalance shaft front bearing from the cylinder block.

#### NOTE:

Be sure to remove the front bearing first.

## FRONT CASE, SILENT SHAFT AND OIL PAN

If it has not been removed, the Rear Bearing Puller Cannot be used.

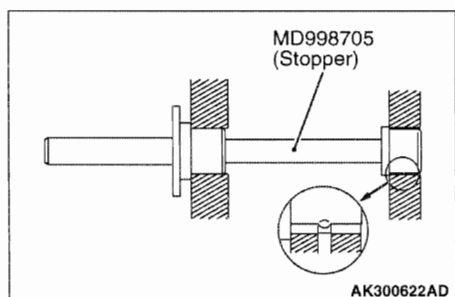
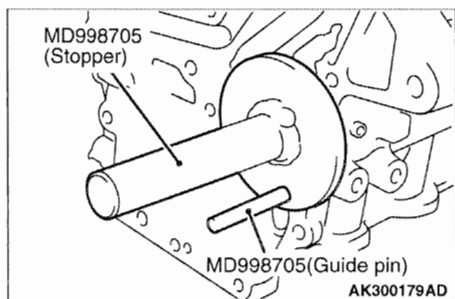
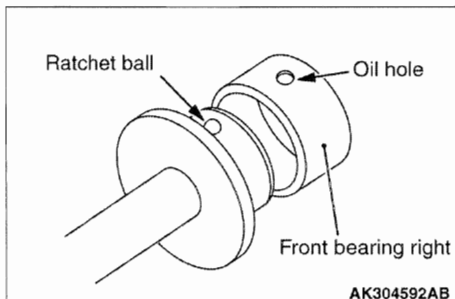
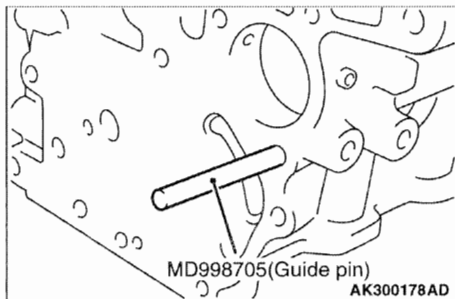
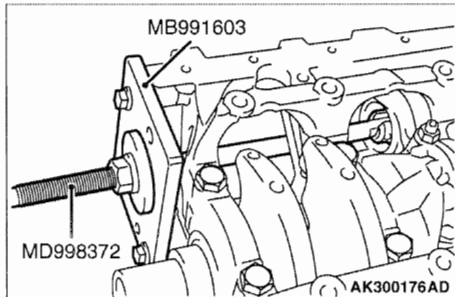

### <<E>> COUNTERBALANCE SHAFT REAR BEARING REMOVAL

1. Using special tool Silent shaft bearing puller (MD998372), remove the right counterbalance shaft rear bearing from the cylinder block.

Using special tools, remove the left counterbalance shaft rear bearing from the cylinder block.

- Silent shaft bearing puller (MD998372)
- Bearing installer stopper (MB991603)

### INSTALLATION SERVICE POINTS

#### >>A<< RIGHT COUNTERBALANCE SHAFT REAR BEARING INSTALLATION

1. Install special tool the guide pin of the Silent shaft bearing installer (MD998705) in the threaded hole of the cylinder block as shown.

2. Align the ratchet ball of the special tool with the oil hole in the rear bearing to install the bearing of the special tool.

3. Apply engine oil to the bearing outer surface and bearing hole in the cylinder block.

4. Using special tool, install the rear bearing. Make sure that the oil hole of the bearing is aligned with the oil hole of the cylinder block.

## FRONT CASE, SILENT SHAFT AND OIL PAN

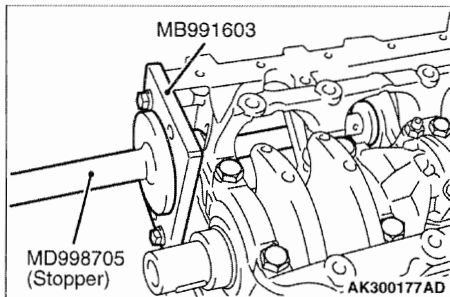

### >>B<< LEFT COUNTERBALANCE SHAFT REAR BEARING INSTALLATION

1. Install special tool Silent shaft bearing installer stopper (MB991603) to the cylinder block.
2. Apply engine oil to the rear bearing outer surface and bearing hole in the cylinder block.

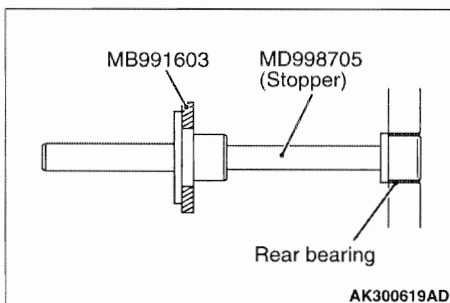

3. Using special tool Silent shaft bearing installer (MD998705), install the rear bearing.

#### NOTE:

The left rear bearing has no oil holes.

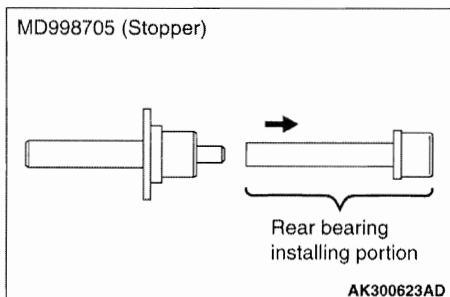

### >>C<< COUNTERBALANCE SHAFT FRONT BEARING INSTALLATION

1. Remove the rear bearing installing portion from the special tool Silent shaft bearing installer (MD998705).

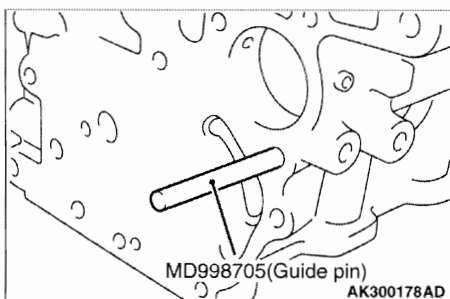

2. Install special tool the guide pin of the Silent shaft bearing installer (MD998705) in the threaded hole of the cylinder block as shown.

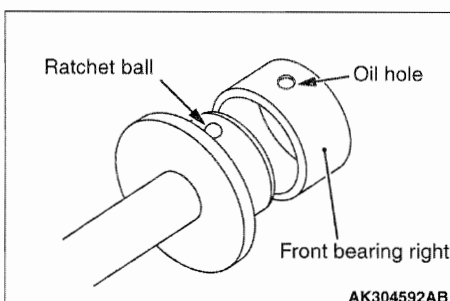

3. Align the ratchet ball of the special tool with the oil hole in the rear bearing to install the bearing of the special tool.

4. Apply engine oil to the front bearing outer surface

## FRONT CASE, SILENT SHAFT AND OIL PAN

and bearing hole in the cylinder.

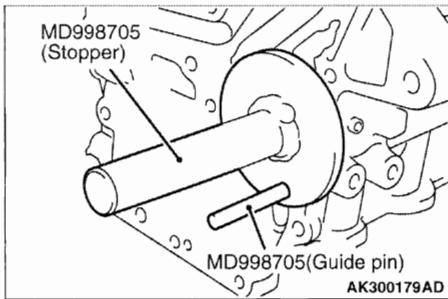

5. Using special tool, install the rear bearing. Make sure that the oil hole of the bearing is aligned with the oil hole of the cylinder block.

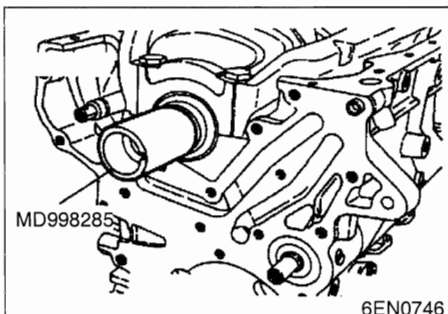
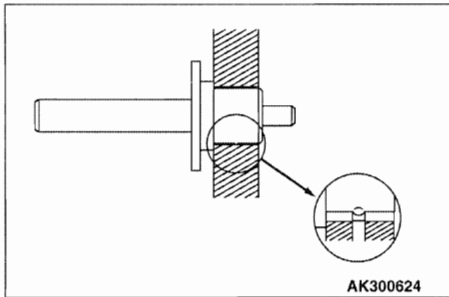

### >>D<< FRONT CASE INSTALLATION

1. Set the special tool on the front end of the Crankshaft and apply a thin coat of engine oil to the outer circumference of the special tool to install the front case.

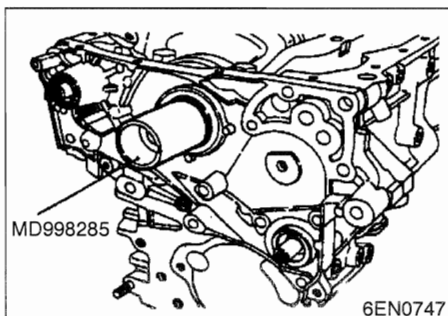

2. Install the front case assembly through a new front case gasket and temporarily tighten the flange bolts (other than those for tightening the filter bracket).

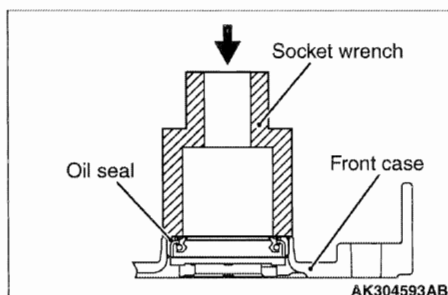

### >>E<< COUNTERBALANCE SHAFT OIL SEAL INSTALLATION

- Using a suitable socket wrench, install the counterbalance shaft oil seal into the front case.



## FRONT CASE, SILENT SHAFT AND OIL PAN

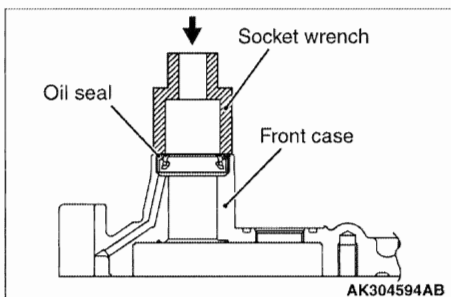

### >>F<< OIL PUMP OIL SEAL INSTALLATION

Using a suitable socket wrench, install the oil pump oil seal into the front case.

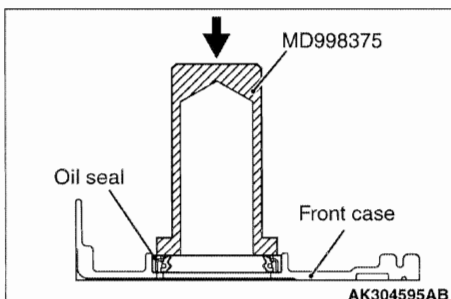

### >>G<< CRANKSHAFT FRONT OIL SEAL INSTALLATION

Using special tool Crankshaft front oil seal installer (MD998375), install the crankshaft front oil seal into the front case.

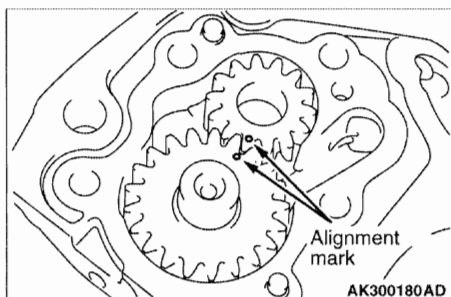

### >>H<< OIL PUMP DRIVEN GEAR/OIL PUMP DRIVE GEAR INSTALLATION

Install the oil pump gears into the front case and align the alignment marks.

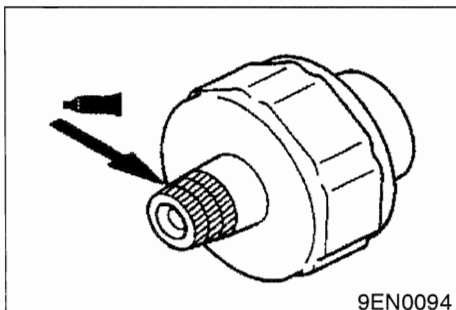

### >>I<< SEALANT APPLICATION TO OIL PRESSURE SWITCH

1. Apply sealant to the threaded portion.

#### Specified Sealant:

**3M ATP part number 8660 or equivalent**

2. Using special tool Oil pressure switch wrench (MD998054), tighten the oil pressure switch to the specified torque.

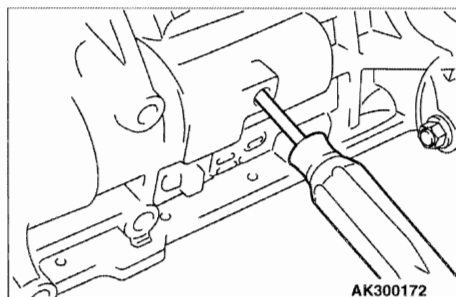

### >>J<< FLANGE BOLT INSTALLATION

1. Insert a Phillips head screwdriver (shank diameter 8 mm) into the hole in the left side of the cylinder block to lock the counterbalance shaft.

## FRONT CASE, SILENT SHAFT AND OIL PAN

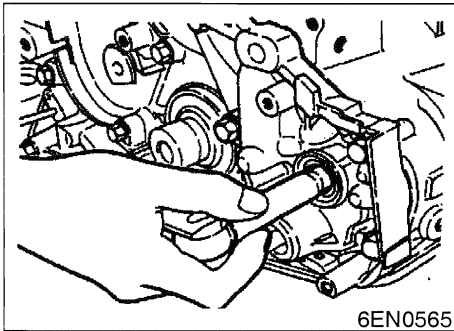

2. Secure the oil pump driven gear onto the left counterbalance shaft by tightening the flange bolt to the specified torque.
3. Pull out the screwdriver and screw in the plug.

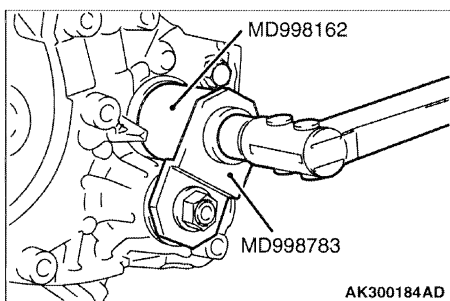

### >>K<< PLUG INSTALLATION

1. Install a new O-ring to the groove of the front case.
2. Install the plug to the front case.
3. Use the special tool to tighten the plug to the specified torque.

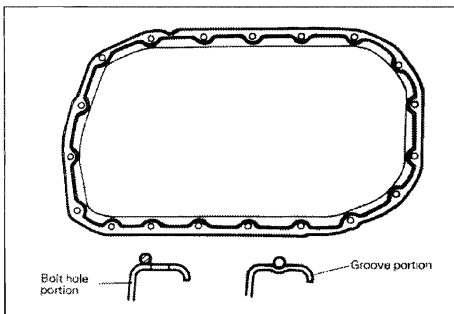

### >>L<< OIL PAN INSTALLATION

1. Thoroughly remove old FIPG from the gasket surfaces of the cylinder block and oil pan.

#### NOTE:

**Do not apply FIPG over remaining old FIPG.  
Doing so could result in oil leakage.**

2. Apply a 4 mm diameter bead of FIPG to the flange surface all around the oil pan.

#### Specified sealant:

**Mitsubishi Genuine Part No.MD970389  
or equivalent**

3. The oil pan should be installed in 15 minutes after the application of sealant
4. Note that the bolts at the location shown are different in length from the others.

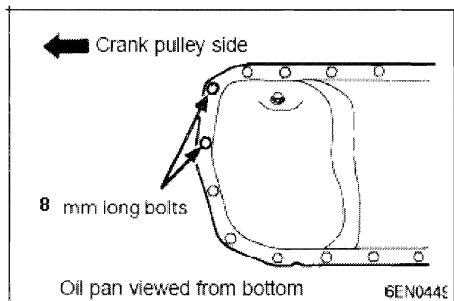

### >>M<< DRAIN PLUG GASKET INSTALLATION

Install the drain plug gasket in the direction shown.

#### NOTE:

If the gasket is installed in the wrong direction, oil leaks will occur.

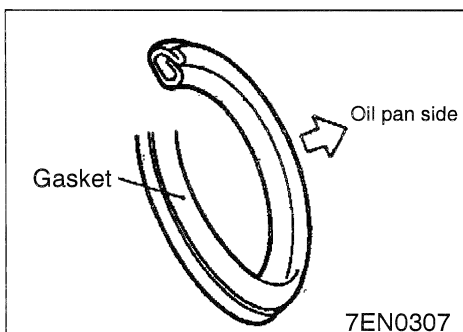

## FRONT CASE, SILENT SHAFT AND OIL PAN

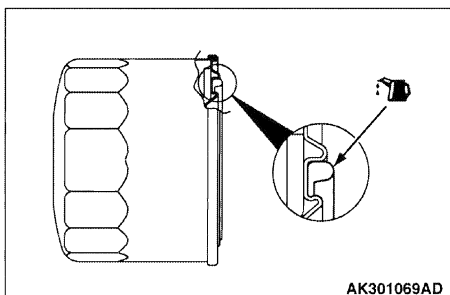

### >>N<< OIL FILTER INSTALLATION

1. Clean the installation surface of the filter bracket.
2. Apply engine oil to the o-ring of the oil filter.

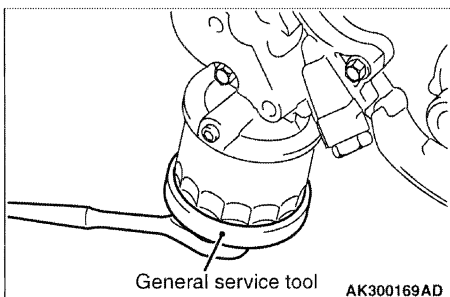

3. Using general service tool, Install the oil filter to the bracket and tighten it to the specified torque.

#### Tightening torque

**Part number MD356000 filter: 14 ± 2 N·m**

4. If a torque wrench cannot be used use the following procedure:
  - (1) Screw in the oil filter until its o-ring contacts the oil filter bracket.
  - (2) Tighten the oil filter as **3/4 turn**.

## INSPECTION

### FRONT CASE

1. Check the oil passage for clogging.  
Clean if necessary.
2. Check the left counterbalance shaft front bearing for wear, damage and seizure. If the bearing is damaged, replace the front case.
3. Check the front case for cracks and other damage.  
Replace cracked or damaged front case.

### OIL SEAL

1. Check the oil seal lip for wear and damage.  
Replace the oil seal if necessary.
2. Check the oil seal lip for deterioration.  
Replace the oil seal if necessary.

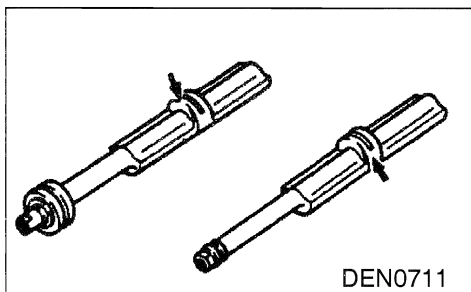

### COUNTERBALANCE SHAFT

1. Check the oil holes for clogging and clean if necessary.
2. Check the journal for seizure, damage and contact with bearing. If there is anything wrong with the

## FRONT CASE, SILENT SHAFT AND OIL PAN

---

journal, replace the counterbalance shaft, bearing or front case assembly if required.

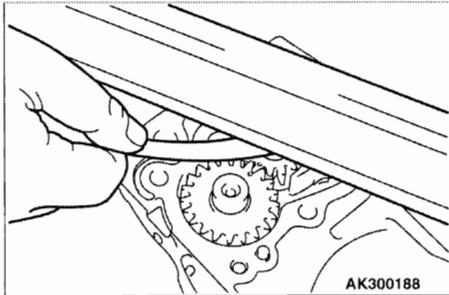

### OIL PUMP

1. Assemble the oil pump gears to the front case and rotate it to ensure smooth rotation with no looseness.
2. Ensure that there is no ridge wear on the contact surface between the front case and the gear surface of the oil pump cover.
3. Check the side clearance.

#### **Standard value:**

**Drive gear : 0.08 - 0.14 mm**

**Driven gear : 0.06 - 0.12 mm**

**PISTON AND CONNECTING ROD**

**REMOVAL AND INSTALLATION**

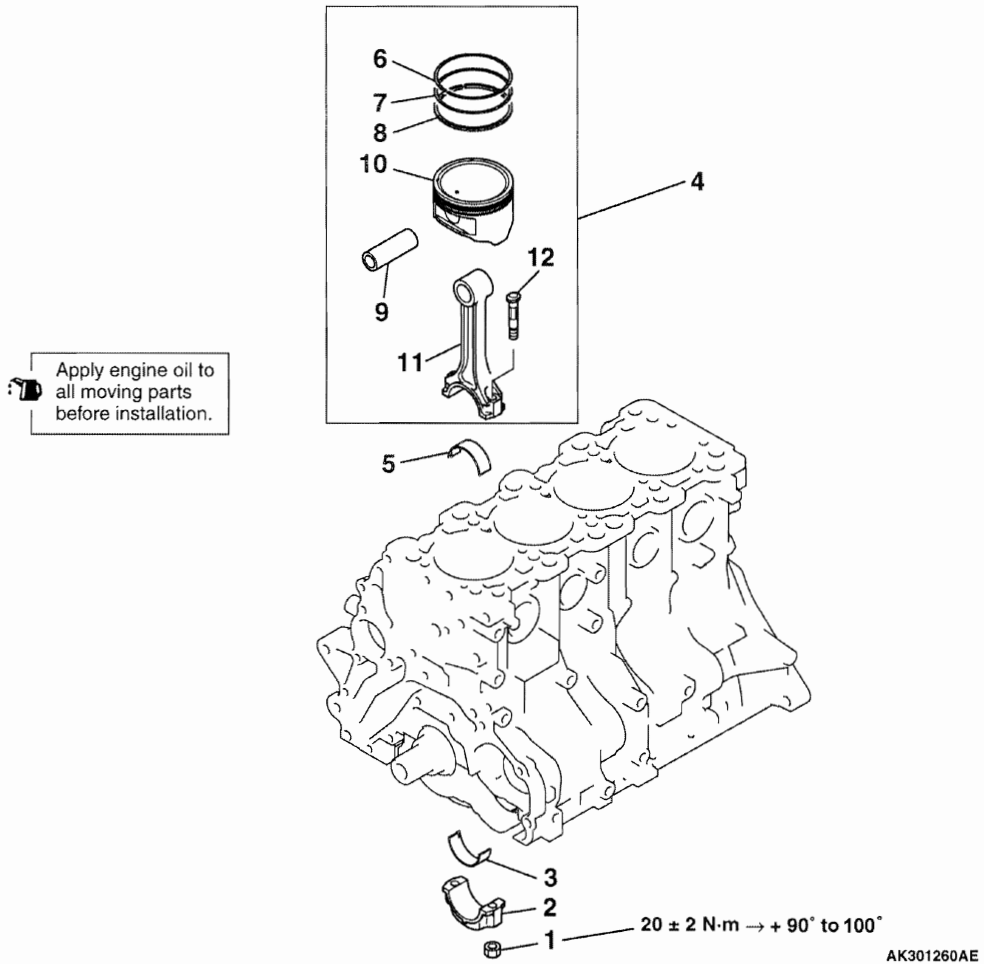

**Removal steps**

- >>G<< 1. Nut
- <<A>> >>F<< 2. Connecting rod cap
- >>E<< 3. Connecting rod bearing
- >>D<< 4. Piston and connecting rod assembly
- >>E<< 5. Connecting rod bearing
- >>C<< 6. Piston ring No. 1
- >>C<< 7. Piston ring No. 2
- >>B<< 8. Oil ring
- <<B>> >>A<< 9. Piston pin
- 10. Piston
- 11. Connecting rod
- 12. Bolt

## PISTON AND CONNECTING ROD

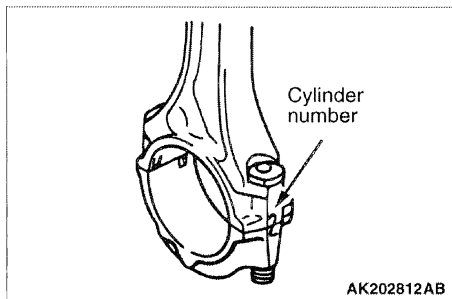

### REMOVAL SERVICE POINTS

#### <<A>>CONNECTING ROD CAP REMOVAL

1. Mark the cylinder number on the side of the connecting rod big end for correct reassembly.
2. Keep the removed connecting rods, caps, and bearings in that order according to the cylinder number.

#### <<B>> PISTON PIN REMOVAL

The special tool Piston pin setting tool (MD998780), consists of the elements shown in the drawing.

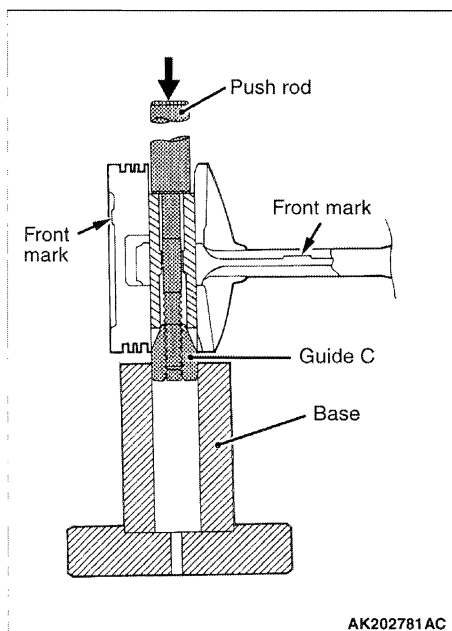
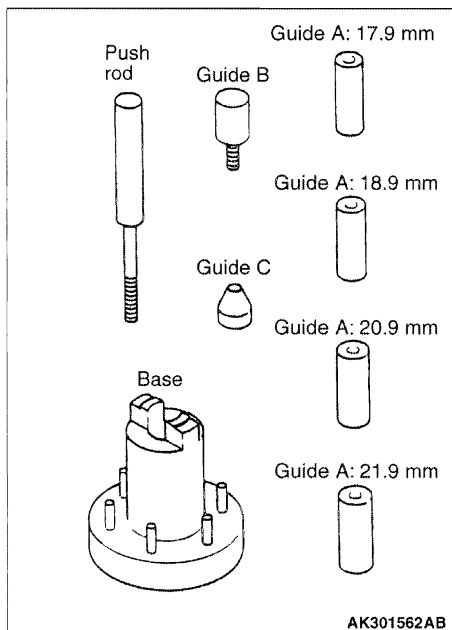

1. Insert the tool element, Push rod, into the piston from the front mark side, then attach the element, Guide C, to the push rod.
2. Place the piston and connecting rod assembly on the element, Base, with the front mark facing up.
3. Use a press to remove the piston pin.

#### Note:

**Keep the disassembled pistons, piston pins and connecting rods cylinder by cylinder.**

## PISTON AND CONNECTING ROD

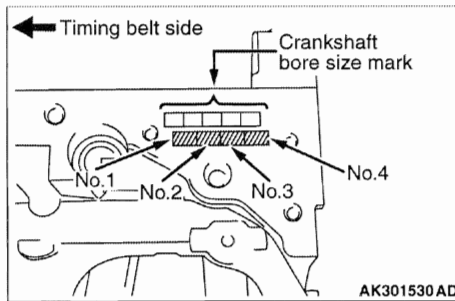

### INSTALLATION SERVICE POINTS

#### >>A<< PISTON PIN INSTALLATION

- When replacing a piston, check the cylinder bore size mark stamped at the indicated location on the cylinder block and select an appropriate replacement piston using the following table.

Cylinder bore size mark	Piston size mark
I	A
II	No mark
III	C

#### NOTE:

**The piston size mark is located on the piston top surface.**

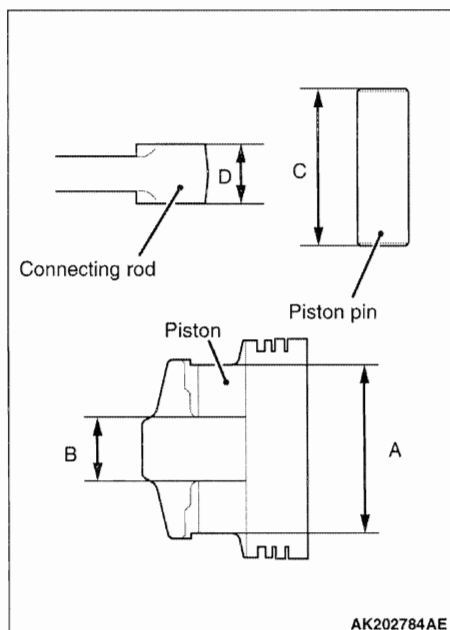

- Measure the following dimensions:
  - A: Piston pin insertion hole length
  - B: Distance between piston bosses
  - C: Piston pin length
  - D: Connecting rod small end width
- Obtain dimension L from the measurements using the following formula.
 
$$L = [(A-C) - (B-D)] \div 2$$
- Insert the tool element, Push rod, into the piston pin and attach the element, Guide A, to the push rod end.
- Assemble the connecting rod with the piston with their front marks facing in the same direction.
- Apply engine oil to the outside surface of the piston pin.
- Insert the assembly of piston pin, Push rod, and Guide A (put together in step 4.) into the piston holes from the front mark side.
- Screw the tool element, Guide B, into the tool element, Guide A until the gap between both the elements is equal to the dimension L (obtained in step 3.) plus 3 mm.

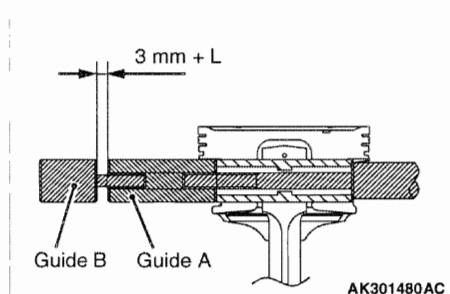

## PISTON AND CONNECTING ROD

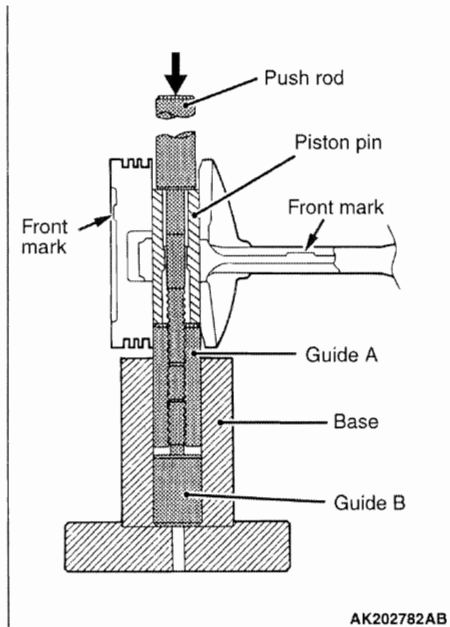

9. Place the piston and connecting rod assembly onto the element, Piston setting base, with the front marks facing up.

10. Install the piston pin using a press. If the required press force is less than the standard value, replace the piston and piston pin assembly or the connecting rod, or both.

**Standard value: 7,350 - 17,200 N**

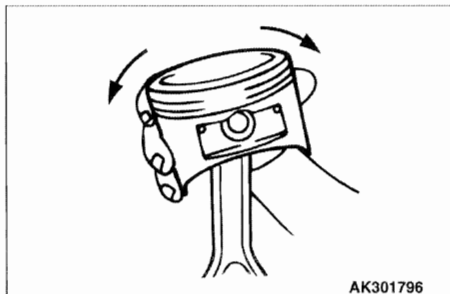

11. Check that the piston moves smoothly.

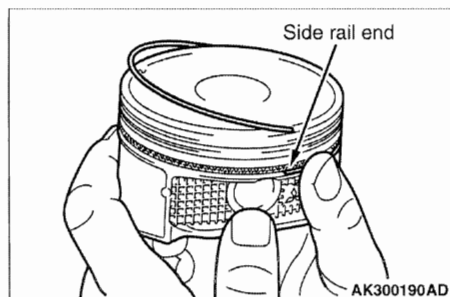

### >>B<< OIL RING INSTALLATION

1. Fit the oil ring spacer into the piston ring groove.
2. Install the upper side rail.

To install the side rail, first fit one end of the rail into the piston groove, then press the remaining portion into position by hand. See illustration.

#### NOTE:

- Do not use a piston ring expander when installing side rail.
- The side rails and spacer may be installed in either direction.
- New spacers and side rails are colored for identification of their sizes.

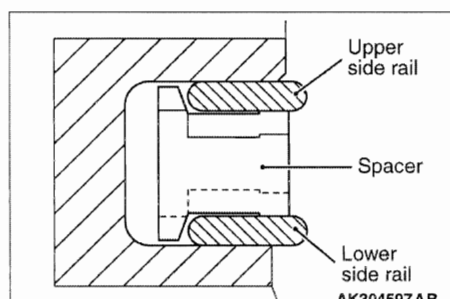



## PISTON AND CONNECTING ROD

Size	Identification color
Standard	None
0.50 mm oversize diameter	Red
1.00 mm oversize diameter	YELLOW

3 .

Install the lower side rail in the same manner as described in step 2.

4. Make sure that the side rails move smoothly in both directions.

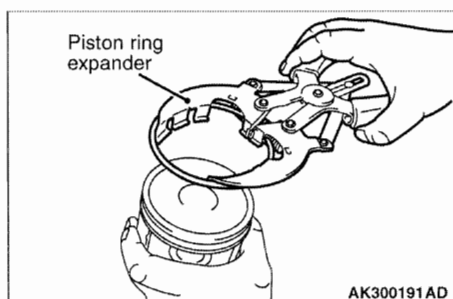

### >>C<< PISTON RING NUMBER 2/PISTON RING NUMBER 1 INSTALLATION

1. Using the piston ring expander, fit number 2 into the number 2 groove of piston.

**NOTE:**

Install piston rings with identification mark facing up, to the piston crown side.

2. Install the number 1 piston ring in the same manner as step 1.

**Identification mark: Number 1 ring: 1R  
Number 2 ring: 2R**

**NOTE:**

- Confirm the profile for No.1 and No.2 piston rings carefully. Install them correctly by careful attention to the direction of top and bottom.
- The identification mark and the size mark are stamped on the upper plane of the piston ring (piston top side).

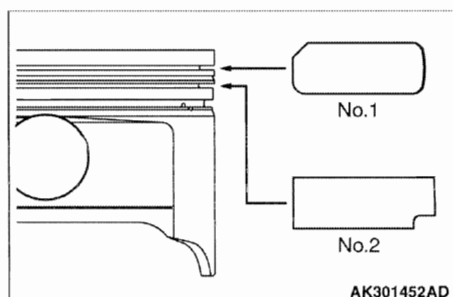

Size	Size mark
Standard	None
0.50 mm oversize diameter	50
1.00 mm oversize diameter	100

3. To prevent wrong installation, check the identification mark of each piston ring. The identification mark is stamped near the ring gap.

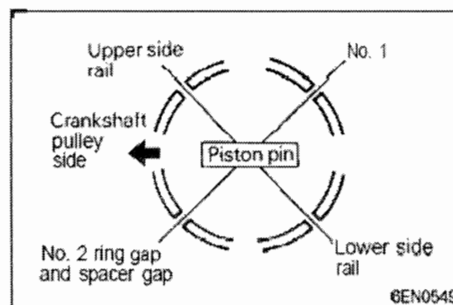

### >>D<< PISTON AND CONNECTING ROD INSTALLATION

1. Apply engine oil on the circumference of the piston, piston rings, and oil ring.
2. Arrange the piston ring and oil ring gaps (side rail and spacer) as shown in the illustration.
3. Rotate the crankshaft so that the crank pin is on the

## PISTON AND CONNECTING ROD

center of the cylinder bore.

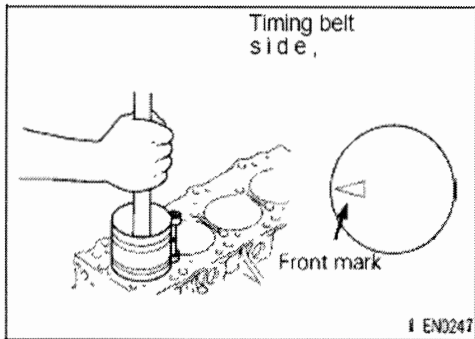

4. Use suitable thread protectors on the connecting rod bolts before inserting the piston and connecting rod assembly into the cylinder block. Care must be taken not to nick the crank pin.
5. Insert the piston and connecting rod assembly into the cylinder with the front mark on the piston crown pointing to the timing belt side.
6. Using a suitable piston ring compressor tool, install the piston and connecting rod assembly into the cylinder block.

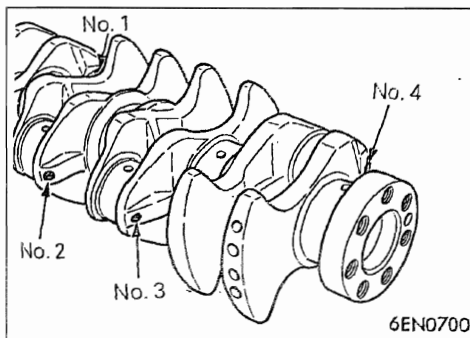

### >>E<< CONNECTING ROD BEARING INSTALLATION

When the bearing needs replacing, select and install a proper bearing by the following procedure.

1. Measure the crankshaft pin diameter and confirm its classification from the following table. On a crankshaft supplied as a service part, identification marks of its pins are stamped at the positions shown in the illustration.
2. The connecting rod bearing identification mark is stamped at the position shown in the illustration.

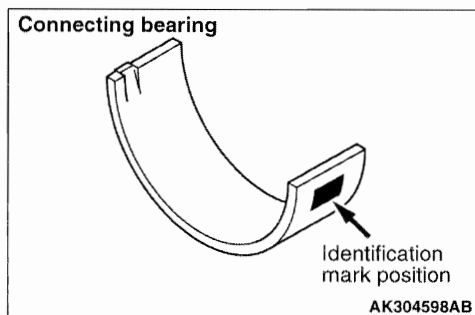

**Connecting rod I.D.:48.000-48.015mm**

Crankshaft pin			Connecting rod bearing		
Classification	Identification color	O.D. mm	Identification mark	Identification color	Thickness mm
I	Yellow	44.995-45.000	1	Yellow	1.487-1.491
II	None	44.985-44.995	2	None	1.491-1.495
III	White	44.980-44.985	3	Blue	1.495-1.499

3. Select a proper bearing from the above table on the basis of the identification data confirmed under

## PISTON AND CONNECTING ROD

Items 1 and 2.

### [Example]

If the measured value of a crankshaft pin outer diameter is 44.996mm, the pin is classified as "1" in the table.

In case the crankshaft is also replaced by a spare

part, check the the identification colors of the pins painted on the new crankshaft. If the color is yellow, for example, the pin is classified as "1".

In the above cases, select the connecting rod bearing having identification mark "1".

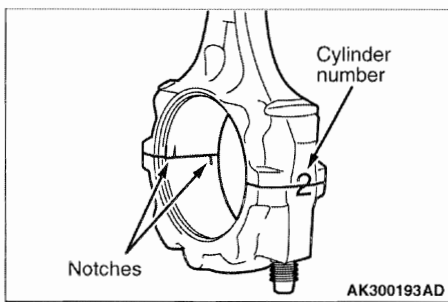

### >>F<< CONNECTING ROD CAP INSTALLATION

1. Verifying the mark made during disassembly, install the bearing cap to the connecting rod. If the connecting rod is new with no index mark, make sure that the bearing locking notches are on the same side as shown.

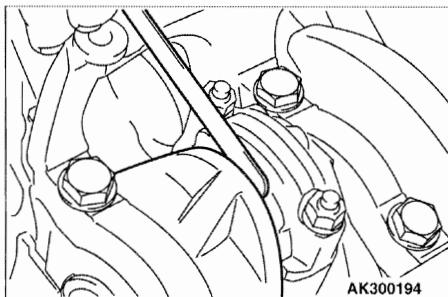

2. Make sure that the connecting rod big end side clearance meets the specification.

**Standard value: 0.10 - 0.25 mm**

**Limit: 0.4 mm**

### >>G<< CONNECTING ROD CAP NUT TIGHTENING

#### NOTE:

Installation of the connecting rod nut should be performed with the cylinder head or the spark plug removed.

1. Since the connecting rod bolts and nuts are torqued using the plastic area tightening method, the bolts should be examined BEFORE reuse. If the bolt threads are "necked down", the bolt should be replaced.

Necking can be checked by running a nut with

## PISTON AND CONNECTING ROD

fingers to the full length of the bolt threads. If the nut does not run down smoothly, the bolt should be replaced.

2. Before installing each nut, apply engine oil to the threaded portion and bearing surface of the nut.

3. Loosely tighten each nut to the bolt.

4. Then tighten the nuts alternately to the specified

torque to install the cap properly.

**Tightening torque:  $20 \pm 2$  N·m**

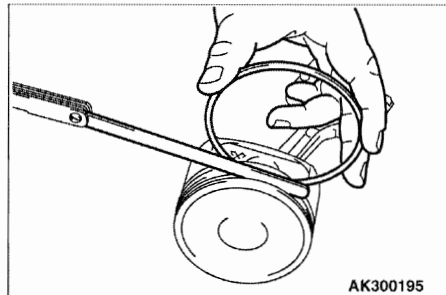
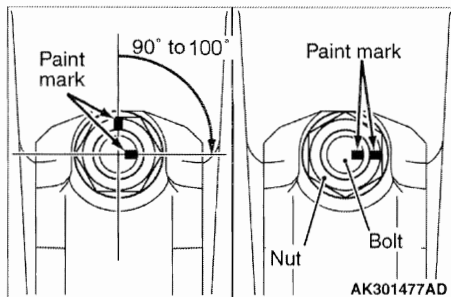

5. Make a paint mark on the head of each nut.

6. Make a paint mark on the bolt end at the position 90 to 100 degrees from the paint mark made on the nut in the direction of tightening the nut.

7. Turn the nut 90 to 100 degrees and make sure that the paint marks on the nut and bolt are aligned.

### NOTE:

If the nut is turned less than 90 degrees, proper fastening performance may not be achieved. Be careful to tighten the nut exactly 90 degrees.

If the nut is overtightened (exceeding 100 degrees), loosen the nut completely and then retighten it by repeating the tightening procedure from step 1.

## INSPECTION

### PISTON

Replace the piston if scratches or seizure is evident on its surfaces (especially the thrust surface). Replace the piston if it is cracked.

### PISTON PIN

1. Insert the piston pin into the piston pin hole with your thumb. You should feel a slight resistance. Replace the piston pin if it can be easily inserted or there is an excessive play.

2. The piston and piston pin must be replaced as an assembly.

## PISTON AND CONNECTING ROD

### PISTON RING

1. Check the piston ring for damage, excessive wear, and breakage. Replace if defects are evident. If the piston has been replaced, the piston rings must also be replaced.

2. Check for clearance between the piston ring and ring groove. If it exceeds the limit, replace the ring or piston, or both.

**Standard value:** Number 1: 0.03 - 0.07 mm

Number 2: 0.02 - 0.06 mm

**Limit : 0.1 mm**

3. Insert the piston ring into the cylinder bore. Force the ring down with a piston, the piston crown being in contact with the ring, to correctly position it at right

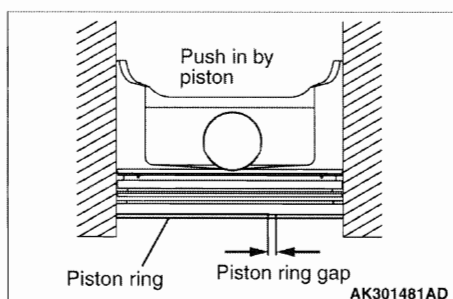

angles to the cylinder wall. Then, measure the end gap with a feeler gauge.

If the ring gap is excessive, replace the piston ring.

**Standard value:** Number 1: 0.25 - 0.35 mm

Number 2: 0.40 - 0.55 mm

Oil: 0.10 - 0.40 mm

**Limit:** Number 1, Number 2: 0.8 mm

Oil: 1.0 mm

### CRANKSHAFT PIN OIL CLEARANCE

#### <PLASTIC GAUGING MATERIAL METHOD>

1. Remove oil from the crankshaft pin and the connecting rod bearing.

2. Cut plastic gauging material to the same length as the width of the bearing and place it on the pin, parallel with its axis.

3. Install the connecting rod cap carefully and tighten the nuts to the specified torque.

4. Carefully remove the connecting rod cap.

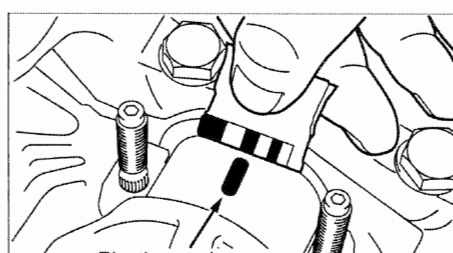
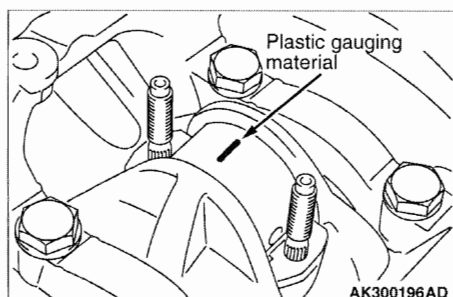

5. Measure the width of the plastic gauging material at its widest part by using a scale printed on the plastic

## PISTON AND CONNECTING ROD

gauging material package.

**Standard value:** 0.02 - 0.05 mm

**Limit:** 0.1 mm

## CRANKSHAFT AND CYLINDER BLOCK

### REMOVAL AND INSTALLATION

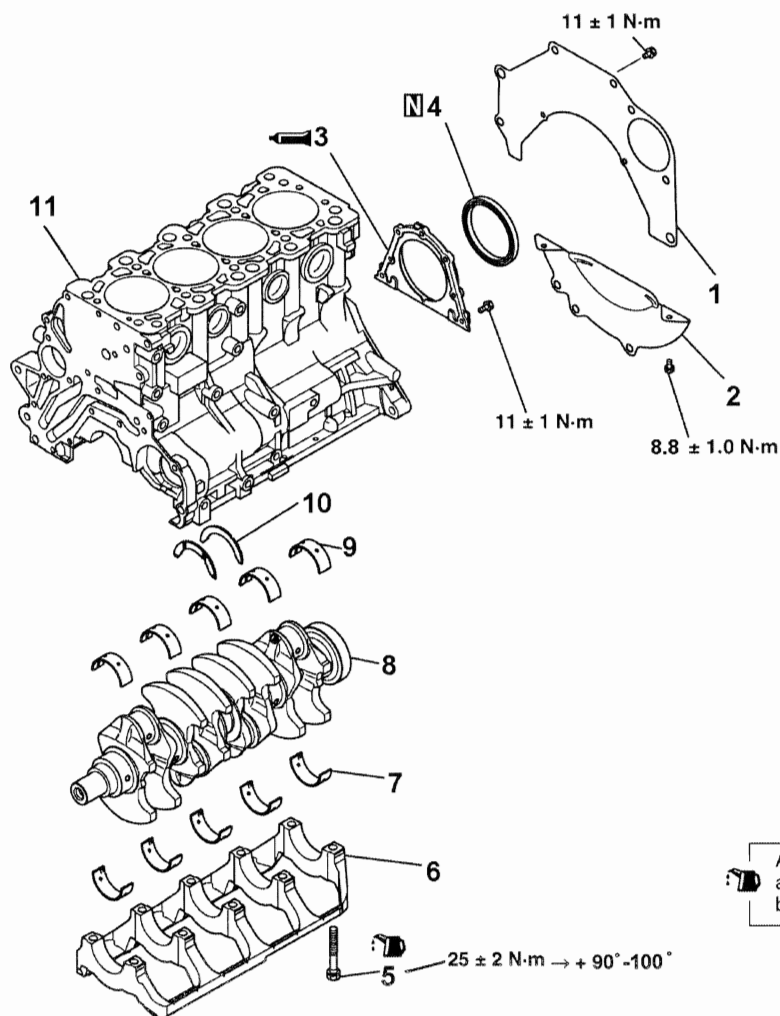

#### Removal steps

1. Rear plate
  2. Bell housing cover
  3. Oil seal case
- >>E<<

## CRANKSHAFT AND CYLINDER BLOCK

- >>D<< 4. Oil seal
- >>C<< 5. Bearing cap bolt
- >>C<< 6. Bearing cap
- >>B<< 7. Crankshaft bearing (Lower)
- 8. Crankshaft
- >>B<< 9. Crankshaft bearing (Upper)
- >>A<< 10. Crankshaft thrust bearing
- 11. Cylinder block

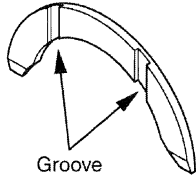
		Diameter and cylinder	No. 1、 2、 4、 5 bearing		No. 3 bearing
			cylinder	block	
		56.994—57.000	0	1、 Green	0、 Black
			1	2、 Yellow	1、 Green
			2	3、 None	2、 Yellow
		56.988—56.994	0	2、 Yellow	1、 Green
			1	3、 None	2、 Yellow
			2	4、 Blue	3、 None
		56.982—56.988	0	3、 None	2、 Yellow
			1	4、 Blue	3、 None
			2	5、 Red	4、 Blue

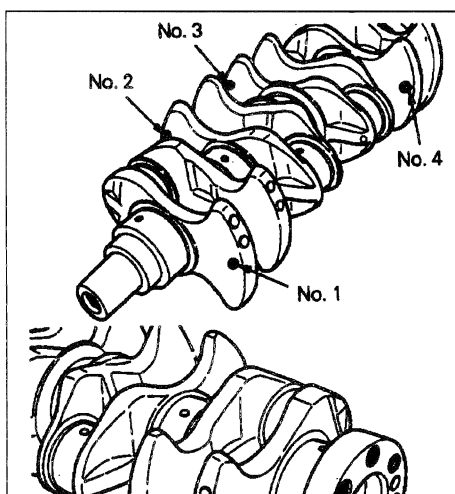

### INSTALLATION SERVICE POINTS

#### >>A<< CRANKSHAFT THRUST BEARING INSTALLATION

1. Install the two thrust bearings in the number 3 bearing bore in the cylinder block. For easier installation, apply engine oil to the bearings; this will help hold them in position.

## CRANKSHAFT AND CYLINDER BLOCK

2. The thrust bearings must be installed with their groove side toward the crankshaft web.

### >>B<< CRANKSHAFT BEARING INSTALLATION

When bearing replacement is required, select and install the correct bearing by the following procedure.

1. Measure the crankshaft journal diameter and confirm its classification from the following table. In the case of a crankshaft supplied as a service part, identification marks of its journals are stamped at the positions shown in the illustration.

2. The cylinder block bearing bore diameter identification marks are stamped at the position shown in the illustration from front to rear beginning at No.1.

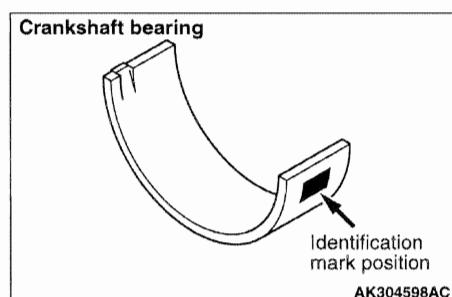
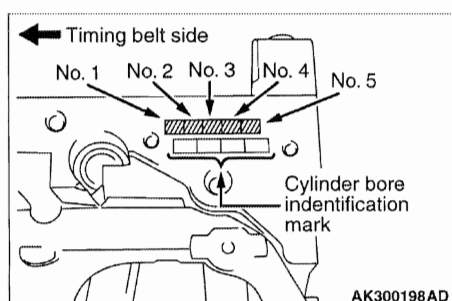
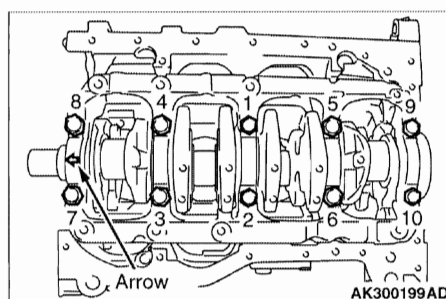
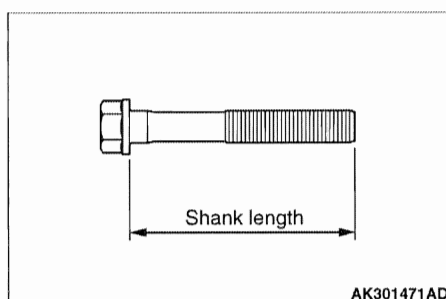
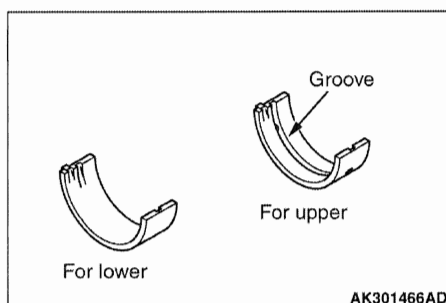

For example, if the crankshaft journal outside diameter identification mark is "□" and cylinder block bearing bore identification mark is "1," select a bearing whose identification mark is "2" for number 1, 2, 4 and 5, and a bearing whose identification mark is "1" for number 3. If there is no identification mark on the crankshaft, measure the journal outside diameter and select a bearing appropriate for the measured value.



## CRANKSHAFT AND CYLINDER BLOCK

3. Install the bearings having an oil groove to the cylinder block.
4. Install the bearings having no oil groove to the bearing cap.

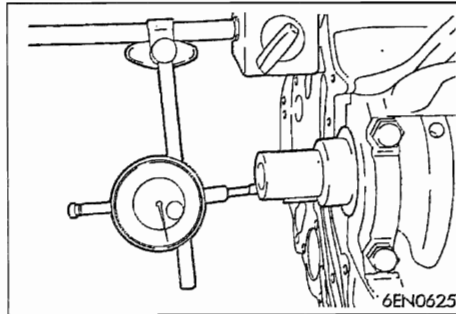

### >>C<< BEARING CAP/BEARING CAP BOLT INSTALLATION

1. Install the bearing caps so that the arrow points to the timing belt side.
2. Before installing the bearing cap bolts, check that the shank length of each bolt meets the limit. If it exceeds the limit, replace the bolt.

**Limit: 71.1 mm**

3. Apply engine oil to the threaded portion and bearing surface of the bolt.
4. Tighten the bolts to the specified in the tightening sequence shown.

**Tightening torque: 25 ± 2 N·m**

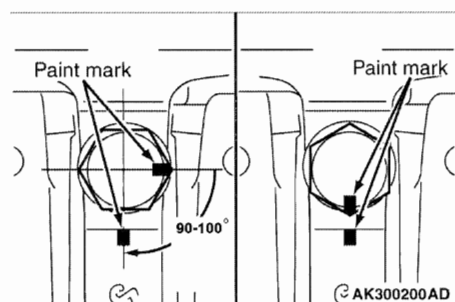
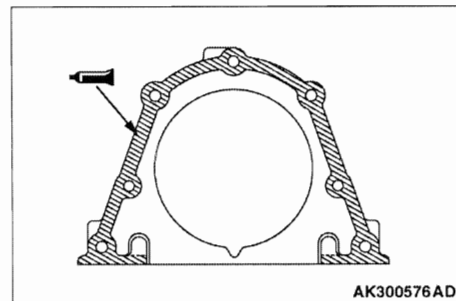
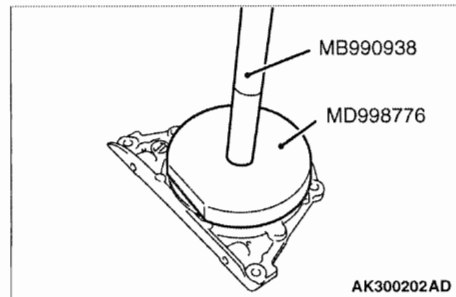

5. Make a paint mark on the head of each bolt.
6. Make a paint mark on the bearing cap 90-100 degrees from the paint mark made on the bolt in the direction of tightening the bolt.

#### NOTE:

- If the bolt is overtightened, loosen the bolt completely and then retighten it by repeating the tightening procedure from step 1.
  - If the bolt is turned less than 90 degrees, proper fastening performance may not be achieved. Be sure to turn the bolt exactly 90 degrees.
7. Turn each bolt 90-100 degrees in the tightening sequence specified in step 4, and make sure that the paint marks on the bolt and cap are aligned.

## CRANKSHAFT AND CYLINDER BLOCK

---

8. Make sure that the crankshaft turns smoothly and the end play is correct. If the end play exceeds the limit, replace the number 3 crankshaft bearings.

**Standard value: 0.05 - 0.18mm**

**Limit: 0.25 mm**

### >>D<< OIL SEAL INSTALLATION

Use the special tools to press-fit the rear oil seal in the rear oil seal case.

- Handle (MB990938)
- Crankshaft rear oil seal installer (MD998776)

### >>E<< SEALANT APPLICATION TO OIL SEAL

#### CASE

1. Remove completely old FIPG remaining on the rear oil seal case and cylinder block.

2. Apply a bead of FIPG to the surface of the rear oil seal case as shown in the drawing.

**Specified sealant: Mitsubishi Genuine Part No.**

**MD970389 or**

**equivalent**

3. Install the oil seal into the cylinder block after applying an appropriate amount of engine oil to the entire circumference of its lip portion.

4. Install the rear oil seal case by tightening its bolts to **11 ± 1 N·m**.

#### NOTE:

- Be sure to install the case quickly while the sealant is wet (within 15 minutes).
- After installation, keep the sealed area away from the oil for approximately one hour.

## CRANKSHAFT AND CYLINDER BLOCK

---

**GENERAC<sup>®</sup>**  
**POWER SYSTEMS, INC.**

*P.O. BOX 310 EAGLE, WI 53119*

**Part No. 0G2832**

**Revision \* (07/14/06)**

**Printed in U.S.A.**

## Free Manuals Download Website

<http://myh66.com>

<http://usermanuals.us>

<http://www.somanuals.com>

<http://www.4manuals.cc>

<http://www.manual-lib.com>

<http://www.404manual.com>

<http://www.luxmanual.com>

<http://aubethermostatmanual.com>

Golf course search by state

<http://golfingnear.com>

Email search by domain

<http://emailbydomain.com>

Auto manuals search

<http://auto.somanuals.com>

TV manuals search

<http://tv.somanuals.com>