

Instructions – Parts List



HIGH FLO[®] Pumps

308793L

Designed for low pressure, medium volume circulation of finishing materials

NOTES:

Stainless steel pumps are severe-duty and electropolished. Use with water-base coatings.

Refer to manual 307837 for adapter kits to mount the displacement pump to an existing motor.

This manual contains **CE** and **Ex II 2 G** compliant models. For a list of models with this compliancy, see pages 5 and 6.

Patent Pending



Read warnings and instructions.

See page 2 for table of contents. See pages 5 and 6 for list of models.

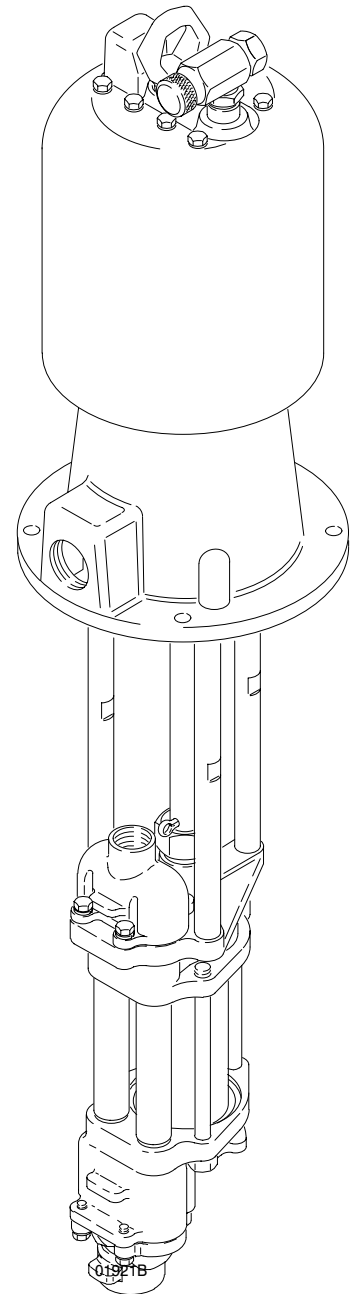

**Senator Pump
Shown**

PROVEN QUALITY. LEADING TECHNOLOGY.

GRACO INC. P.O. BOX 1441 MINNEAPOLIS, MN 55440-1441
Copyright 1997, Graco Inc. is registered to I.S. EN ISO 9001



Table of Contents

Symbols	2	Viscount Pumps	36
Warnings	2	Carbon Steel Displacement Pumps	37
Pump Models	5	Electropolished Stainless Steel	
Installation		Displacement Pumps	39
All Pumps	7	Electropolished Stainless Steel	
Air-Powered Pumps	10	Displacement Pumps, with bsp threads	41
Hydraulic-Powered Pumps	12	Seal and Throat Packing Kits	45
Operation		Conversion Kits	45
All Pumps	15	Accessories	47
Air-Powered Pumps	16	Dimensions	47
Hydraulic-Powered Pumps	17	Mounting Diagrams	48
Maintenance	18	Technical Data and Performance Charts	
Troubleshooting	21	President Pumps	50
Service	22	Senator Pumps	55
Parts		Bulldog Pumps	56
President Pumps	32	Viscount Pumps	57
Quiet Senator Pumps	34	Warranty	60
Quiet Bulldog Pumps	35	Graco Information	60

Symbols

Warning Symbol



This symbol alerts you to the possibility of serious injury or death if you do not follow the instructions.

Caution Symbol



This symbol alerts you to the possibility of damage to or destruction of equipment if you do not follow the instructions.

WARNING

PRESSURIZED EQUIPMENT HAZARD

Spray from the gun/valve, hose leaks, or ruptured components can splash fluid in the eyes or on the skin and cause serious injury.

- Do not point the gun/valve at anyone or at any part of the body.
- Do not stop or deflect leaks with your hand, body, glove or rag.
- Follow the **Pressure Relief Procedure** on page 15 whenever you: are instructed to relieve pressure; stop spraying/dispensing; clean, check, or service the equipment; and install or clean the spray tip/nozzle.
- Tighten all fluid connections before operating the equipment.
- Check the hoses, tubes, and couplings daily. Replace worn, damaged, or loose parts immediately. Permanently coupled hoses cannot be repaired; replace the entire hose.

WARNING



INSTRUCTIONS

EQUIPMENT MISUSE HAZARD

Equipment misuse can cause the equipment to rupture or malfunction and result in serious injury.

- This equipment is for professional use only.
- Read all instruction manuals, tags, and labels before operating the equipment.
- Use the equipment only for its intended purpose. If you are uncertain about usage, call your Graco distributor.
- Do not alter or modify this equipment. Use only genuine Graco parts and accessories.
- Check equipment daily. Repair or replace worn or damaged parts immediately.
- Do not exceed the maximum working pressure stated on the equipment or in the **Technical Data** for your equipment. Do not exceed the maximum working pressure of the lowest rated component in your system.
- Use fluids and solvents which are compatible with the equipment wetted parts. Refer to the **Technical Data** section of all equipment manuals. Read the fluid and solvent manufacturer's warnings.
- Do not use hoses to pull equipment.
- Route hoses away from traffic areas, sharp edges, moving parts, and hot surfaces. Do not expose Graco hoses to temperatures above 82°C (180°F) or below -40°C (-40°F).
- Wear hearing protection when operating this equipment.
- Do not lift pressurized equipment.
- Comply with all applicable local, state, and national fire, electrical, and safety regulations.



MOVING PARTS HAZARD

Moving parts, such as the air motor piston, can pinch or amputate your fingers.

- Keep clear of all moving parts when starting or operating the pump.
- Before servicing the equipment, follow the **Pressure Relief Procedure** on page 15 to prevent the equipment from starting unexpectedly.

WARNING



FIRE AND EXPLOSION HAZARD

Improper grounding, poor ventilation, open flames or sparks can cause a hazardous condition and result in a fire or explosion and serious injury.

- Ground the equipment and the object being sprayed. Refer to **Grounding** on page 7.
- If there is any static sparking or you feel an electric shock while using this equipment, **stop spraying/dispensing immediately**. Do not use the equipment until you identify and correct the problem.
- Provide fresh air ventilation to avoid the buildup of flammable fumes from solvents or the fluid being sprayed/dispensed.
- Keep the spray/dispense area free of debris, including solvent, rags, and gasoline.
- Electrically disconnect all equipment in the spray/dispense area.
- Extinguish all open flames or pilot lights in the spray/dispense area.
- Do not smoke in the spray/dispense area.
- Do not turn on or off any light switch in the spray/dispense area while operating or if fumes are present.
- Do not operate a gasoline engine in the spray/dispense area.



TOXIC FLUID HAZARD

Hazardous fluid or toxic fumes can cause serious injury or death if splashed in the eyes or on the skin, inhaled, or swallowed.



- Know the specific hazards of the fluid you are using.
- Store hazardous fluid in an approved container. Dispose of hazardous fluid according to all local, state and national guidelines.
- Always wear protective eyewear, gloves, clothing and respirator as recommended by the fluid and solvent manufacturer.

Pump Models

NOTE: These pumps are not suitable for metering. Contact your Graco distributor for more information.

CARBON STEEL MODELS

Complete Pump Part No.	Ratio and Type (parts list page)	Displacement Pump (parts list page)	Maximum Air (or Hydraulic*) Working Pressure	Maximum Fluid Working Pressure
			MPa, bar (psi)	MPa, bar (psi)
**220560, Series B	2:1 President (32)	239834, Series A (37)	1.2, 12 (180)	2.5, 25 (360)
**220561, Series B	3:1 President (32)	239833, Series A (37)	1.1, 11 (166)	3.4, 34 (500)
**239855, Series A	3:1 President, stubby (32)	239833, Series A (37)	1.1, 11 (166)	3.4, 34 (500)
**237223, Series B	3:1 President, w/PTFE packings (32)	239860, Series A (37)	1.1, 11 (166)	3.4, 34 (500)
**220565, Series B	3.5:1 Quiet Senator (34)	239834, Series A (37)	0.7, 7.0 (100)	2.4, 24 (350)
**220567, Series B	2.5:1 Quiet Senator (34)	239835, Series A (37)	0.7, 7.0 (100)	1.7, 17 (250)
**220577, Series B	4:1 Quiet Bulldog (35)	239835, Series A (37)	0.7, 7.0 (100)	2.8, 28 (400)
**236601, Series B	Viscount I+ (36)	239833, Series A (37)	10.3, 103 (1500)*	3.1, 31 (450)
**236605, Series B	Viscount I+ (36)	239834, Series A (37)	10.3, 103 (1500)*	2.1, 21 (300)
**236712, Series B	Viscount I+ (36)	239835, Series A (37)	10.3, 103 (1500)*	1.5, 15 (225)

** This model is  and  compliant.

Pump Models

NOTE: These pumps are not suitable for metering. Contact your Graco distributor for more information.



SEVERE-DUTY ELECTROPOLISHED STAINLESS STEEL MODELS

Complete Pump Part No.	Ratio and Type (parts list page)	Displacement Pump (parts list page)	Maximum Air (or Hydraulic*) Working Pressure	Maximum Fluid Working Pressure
			MPa, bar (psi)	MPa, bar (psi)
**220562, Series C	1.5:1 President (32)	239838, Series B (39)	1.2, 12 (180)	1.9, 19 (270)
**220563, Series C	2:1 President (32)	239837, Series B (39)	1.2, 12 (180)	2.5, 25 (360)
**220564, Series C	3:1 President (32)	239836, Series B (39)	1.1, 11 (166)	3.4, 34 (500)
**239854, Series B	3:1 President, stubby (32)	239836, Series B (39)	1.1, 11 (166)	3.4, 34 (500)
**237222, Series C	3:1 President, w/PTFE packings (32)	239859, Series B (39)	1.1, 11 (166)	3.4, 34 (500)
**220568, Series C	3.5:1 Quiet Senator (34)	239837, Series B (39)	0.7, 7.0 (100)	2.4, 24 (350)
**220570, Series C	2.5:1 Quiet Senator (34)	239838, Series B (39)	0.7, 7.0 (100)	1.7, 17 (250)
**220578, Series C	4:1 Quiet Bulldog (35)	239838, Series B (39)	0.7, 7.0 (100)	2.8, 28 (400)
**236602, Series C	Viscount I+ (36)	239836, Series B (39)	10.3, 103 (1500)*	3.1, 31 (450)
**236606, Series C	Viscount I+ (36)	239837, Series B (39)	10.3, 103 (1500)*	2.1, 21 (300)
**236713, Series C	Viscount I+ (36)	239838, Series B (39)	10.3, 103 (1500)*	1.5, 15 (225)
244142, Series A	Viscount I+ (36)	239859, Series B (39)	10.3, 103 (1500)*	3.1, 31 (450)

SEVERE-DUTY ELECTROPOLISHED STAINLESS STEEL MODELS, WITH BSP THREADS

Complete Pump Part No.	Ratio and Type (parts list page)	Displacement Pump (parts list page)	Maximum Air Working Pressure	Maximum Fluid Working Pressure
			MPa, bar (psi)	MPa, bar (psi)
**240618, Series A	3:1 President (32)	240610, Series A, with tri-clamp adapters (41)	1.1, 11 (166)	3.4, 34 (500)
**240619, Series A	3:1 President (32)	240611, Series A, without tri-clamp adapters (41)	1.1, 11 (166)	3.4, 34 (500)
**240625, Series B	4:1 Quiet Bulldog (35)	240606, Series A, with tri-clamp adapters (41)	0.7, 7.0 (100)	2.8, 28 (400)
**240626, Series B	4:1 Quiet Bulldog (35)	240607, Series A, without tri-clamp adapters (41)	0.7, 7.0 (100)	2.8, 28 (400)

NOTE: High-Flo displacement pumps 240608 and 240612 (with tri-clamp adapters) and 240609 and 240613 (without tri-clamp adapters) are available as options. See page 43 for parts.

** This model is  and  compliant.

Installation (All Pumps)

Application

The High-Flo pump is designed for low pressure, medium volume circulation of finishing materials such as paints and stains.

Do not use this pump for flushing or purging lines with caustics, acids, abrasive line strippers, and other similar fluids.

Typical Installation

The Typical Installations shown in Figs. 4 and 5, and the following installation information are only guides. Proper sizing of the pump, accessories and lines is essential to get the maximum performance from your system. Contact your Graco distributor for assistance in designing a system to meet your needs.

Grounding

⚠ WARNING	
	FIRE AND EXPLOSION HAZARD Before operating the pump, ground the system as explained below. Also read the section FIRE AND EXPLOSION HAZARD on page 4.

1. *Pump*: use the ground wire and clamp. See Fig. 1. Loosen the grounding lug locknut (W) and washer (X). Insert one end of a 12 ga (1.5 mm²) minimum ground wire (Y) into the slot in lug (Z) and tighten the locknut securely. Connect the other end of the wire to a true earth ground. Order Part No. 237569 Ground Wire and Clamp.

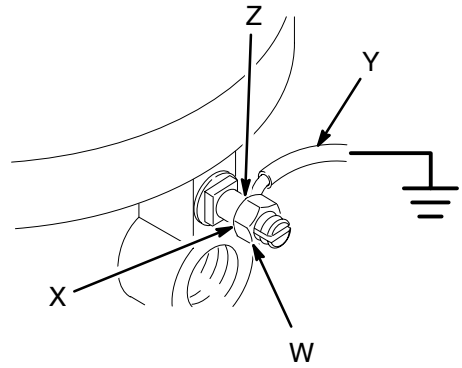

Fig. 1

0720

2. *Air and fluid hoses*: use only electrically conductive hoses.
3. *Air compressor or hydraulic power supply*: follow manufacturer's recommendations.
4. *Surge tank*: use a ground wire and clamp. See Fig. 1.
5. *Spray gun*: ground through connection to a properly grounded fluid hose and pump.
6. *Fluid supply container*: follow your local code.
7. *Object being sprayed*: follow your local code.
8. *Solvent pails used when flushing*: follow your local code. Use only metal pails, which are conductive, placed on a grounded surface. Do not place the pail on a nonconductive surface, such as paper or cardboard, which interrupts the grounding continuity.
9. *To maintain grounding continuity when flushing or relieving pressure*, hold a metal part of the spray gun firmly to the side of a grounded *metal* pail, then trigger the gun.

Installation (All Pumps)

Mount the Pump

This pump can be mounted on a floor stand, cart, wall bracket, or drum. The floor stand shown in Figs. 4 and 5 is Part. No. 220581.

Instructions for mounting the pump are supplied with the mounting accessory.

Plumbing

Most displacement pumps have a 1-1/2 in. npt(f) fluid inlet and a 1 in. npt(f) fluid outlet. Models 240606, 240607, 240608, 240609, 240610, 240611, 240612, and 240613, have a 1-1/2 in. bsp(f) fluid inlet and a 1-1/4 in. bsp(f) fluid outlet.

Use a minimum 25 mm (1 in.) diameter pipe or hose between the pump outlet and any supply line accessories. Use a minimum 38 mm (1-1/2 in.) diameter pipe or hose between the mix tanks and pump inlet.

When using a stainless steel pump, use stainless steel plumbing to maintain a corrosion-resistant system.

Pumps With Tri-Clamp Adapters

Displacement Pumps 240606, 240608, 240610, and 240612 include tri-clamp adapters which allow sanitary pipe to be connected to the pump inlet and outlet. Refer to Fig. 2.

Install a 1-1/2 in. tri-clamp gasket (GG, not supplied) in the groove of the tri-clamp adapter (LL). Mate the tri-clamp adapter with the sanitary pipe and secure with two clamps (HH), bolts (JJ), and nuts (KK) (not supplied). Install the bolts in opposite directions.

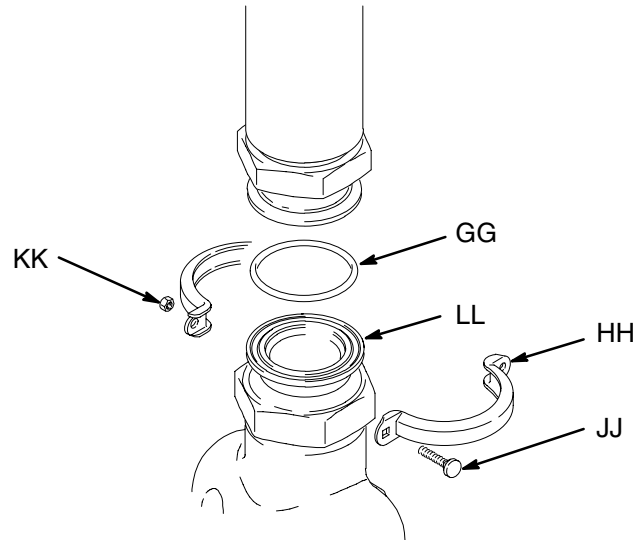

8689A

Fig. 2

Installation (All Pumps)

Non-Circulating Systems

In non-circulating systems with a fluid outlet that can be closed off (causing the pump to stall), install a fluid pressure relief valve (AA) and a return line (BB) leading back to the fluid supply line (C). See Fig. 3.

⚠ WARNING

COMPONENT RUPTURE HAZARD



The pressure relief valve reduces the risk of the pump overpressurizing if the piston seal is worn and leaking, and the fluid outlet is closed off. Install the valve so the arrow on its body matches the direction of fluid flow.

Do not install a fluid shutoff valve in the fluid line between the pump outlet (DD) and the pump inlet (CC). Doing so defeats the purpose of the pressure relief valve if the shutoff valve is closed, resulting in pump overpressurization. Overpressurization can cause the pump or components to rupture, resulting in serious injury and property damage.

Pressure Relief Valve (for non-circulating systems)

KEY

- B** Pump Stand
- C** Fluid Supply Line; 38 mm (1-1/2 in.) minimum diameter
- D** Fluid Shutoff Valve
- E** Fluid Line; 25 mm (1 in.) minimum diameter
- AA** External Pressure Relief Valve
- BB** Fluid Return Line
- CC** Pump Fluid Inlet
- DD** Pump Fluid Outlet



Do not install a fluid shutoff valve in the fluid line between the pump outlet (DD) and the pump inlet (CC). See the **WARNING** above.

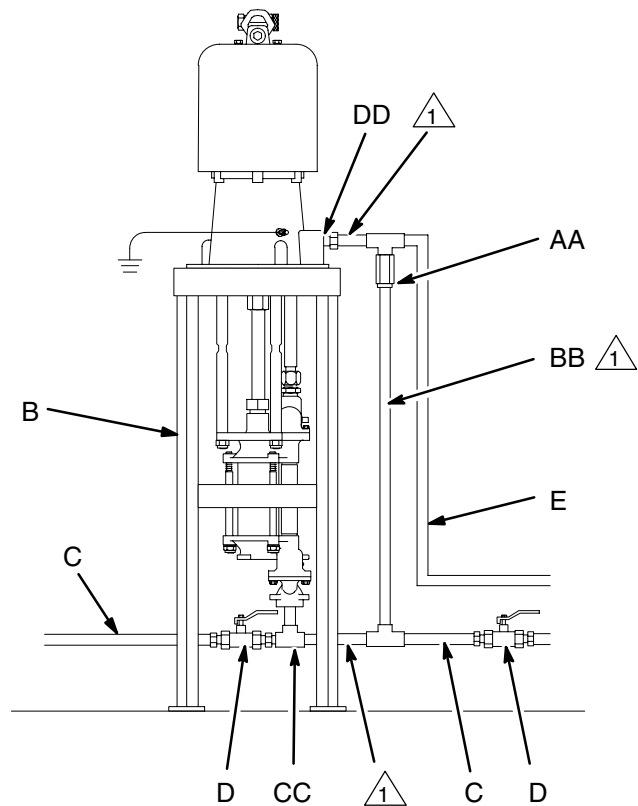

Fig. 3

7656A

Installation (Air-Powered Pumps)

Air Line to Motor

WARNING

A bleed-type master air valve (M) is required in your system, to help reduce the risk of serious injury including splashing fluid in the eyes or on the skin, and injury from moving parts if you are adjusting or repairing the pump.

The bleed-type master air valve relieves air trapped between this valve and the pump after the air is shut off. Trapped air can cause the pump to cycle unexpectedly. Locate the valve close to the pump. Order Part No. 113333.

1. The air line lubricator (N) automatically lubricates the air motor to prevent corrosion. See Fig. 4.
2. The bleed-type master air valve (M) relieves air trapped between itself and the motor, when the valve is closed. Install one valve close to the pump, downstream from the air regulator. Install a second bleed valve upstream from all other air line accessories, to isolate the accessories for servicing.
3. The air regulator (L) controls pump speed.
4. The pump runaway valve (P) shuts off the air to the pump if the pump speed exceeds your pre-adjusted setting. Running a pump too fast can damage it.

5. The air filter (K) removes harmful dirt and moisture from the compressed air supply.
6. The air supply line (J) must be large enough to supply the proper volume of air to the motor.

Fluid Line from Pump

WARNING

A fluid drain valve (U) is required in your system, to help reduce the risk of serious injury including splashing in the eyes or on the skin if the pump cycles unexpectedly.

Locate one valve downstream from the pump outlet and another valve downstream from the surge tank (G). These drain valves are used to relieve fluid pressure in the pump and surge tank during shut-down.

1. The surge tank (G) reduces fluid surging to prevent backflow into the pump. Mounting instructions are supplied with the tank.
2. The shutoff valves (D) before and after the surge tank, and between each mix tank and the pump fluid inlet, isolate these components for servicing.
3. Be sure the supply line (C) between the pump and mix tanks (A) is level.

Installation (Air-Powered Pumps)

KEY

- A Mix Tank
- B Pump Stand
- C Fluid Supply Line; 38 mm (1-1/2 in.) minimum diameter
- D Fluid Shutoff Valve
- E Fluid Line; 25 mm (1 in.) minimum diameter
- F Surge Tank Stand
- G Surge Tank
- H Ground Wire (required; see page 7 for installation)
- J Air Supply Line
- K Airline Filter
- L Air Regulator and Gauge
- M Bleed-Type Master Air Valve (required)
- N Airline Lubricator
- P Pump Runaway Control Valve
- U Fluid Drain Valve (required)

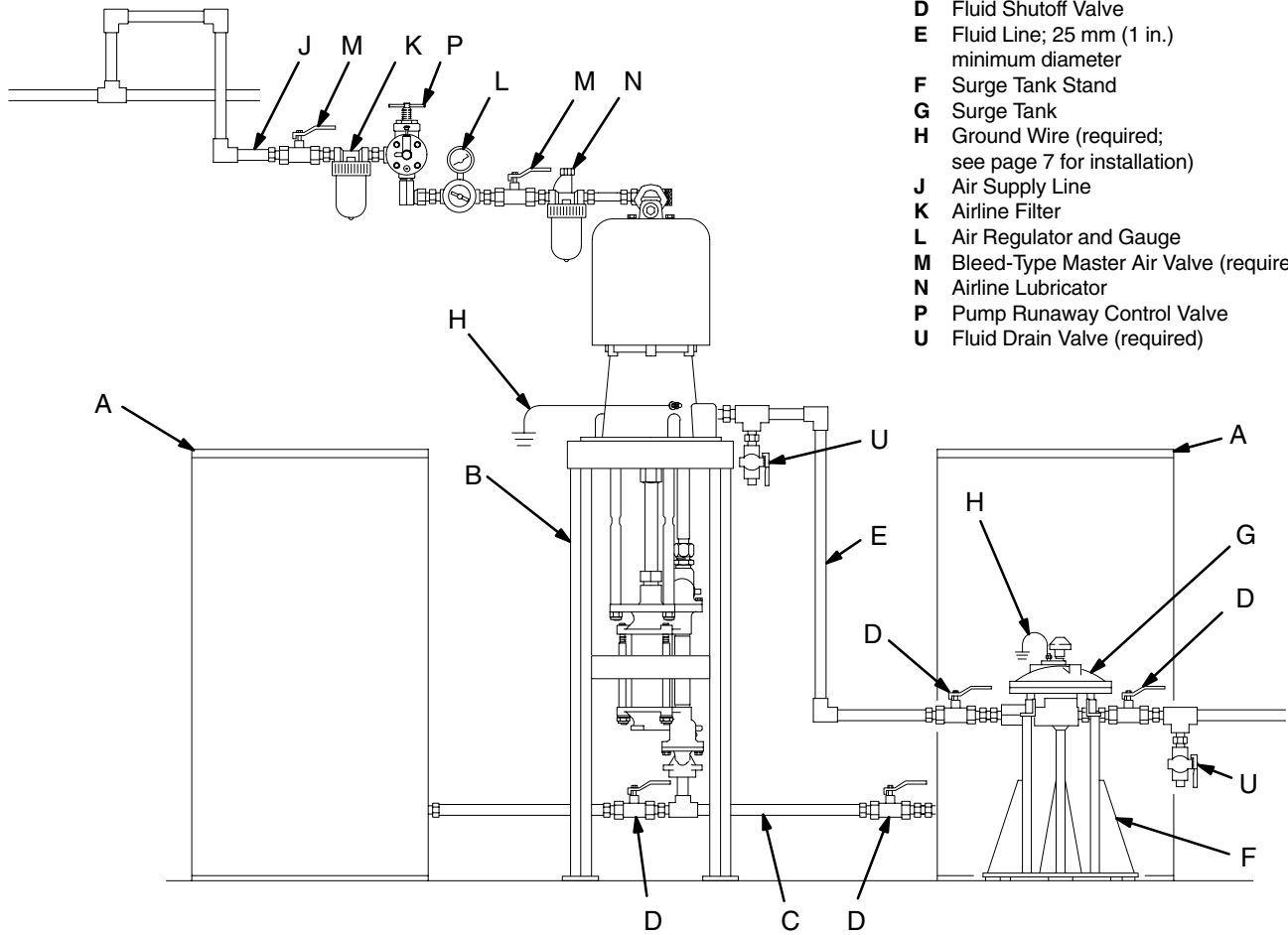

Fig. 4

01923A

Installation (Hydraulic-Powered Pumps)

Hydraulic Power Supply

CAUTION

The Hydraulic Power Supply must be kept clean at all times to avoid damage to the motor and hydraulic power supply.

1. Blow out hydraulic lines with air and flush thoroughly before connection to the motor.
2. Plug hydraulic inlets, outlets, and line ends when disconnecting them for any reason.

1. Be sure the power supply can provide sufficient power to the motor.
2. Be sure the power supply is equipped with a suction filter to the hydraulic pump.

Hydraulic Supply to Motor

NOTE: The motor's hydraulic inlet is 3/4 in., 37° flare. Use a minimum 13 mm (1/2 in.) ID hydraulic supply line (L).

1. The supply line shutoff valve (S) isolates the motor when servicing the system. See Fig. 5.
2. The hydraulic fluid pressure gauge (Q) monitors the hydraulic oil pressure to the motor. This helps avoid overpressurizing the motor or displacement pump.
3. The pressure- and temperature-compensated flow control valve (T) prevents the motor from running too fast, which can damage it.
4. The pressure reducing valve (P) which has a drain line (M) running to the return line (K), controls the hydraulic pressure to the motor.

Hydraulic Return from Motor

NOTE: The motor's hydraulic outlet is 7/8 in., 37° flare. Use a minimum 16 mm (5/8 in.) ID hydraulic return line (K).

1. The return line shutoff valve (R) isolates the motor when servicing the system.

CAUTION

To avoid damage to the pump, never use the return line shutoff valve to control the hydraulic flow. Do not install any flow control devices on the hydraulic return line.

2. The 10 micron size return filter (J) removes residue from the hydraulic fluid to help keep the system running smoothly.

Fluid Line from Pump

WARNING

A fluid drain valve (U) is required in your system, to help reduce the risk of serious injury including splashing in the eyes or on the skin if the pump cycles unexpectedly.

Locate one valve downstream from the pump outlet and another valve downstream from the surge tank (G). These drain valves are used to relieve fluid pressure in the pump and surge tank during shutdown.

1. The surge tank (G) reduces fluid surging to prevent backflow into the pump. Mounting instructions are supplied with the tank.
2. The shutoff valves (D) before and after the surge tank, and between each mix tank and the pump fluid inlet, isolate these components for servicing.
3. Be sure the supply line (C) between the pump and mix tanks (A) is level.

Installation (Hydraulic-Powered Pumps)

KEY

- | | | | |
|--|--|--|---------------------------------------|
| A Mix Tank | E Fluid Line; 25 mm (1 in.) minimum diameter | J 10 Micron Return Filter | P Pressure Reducing Valve |
| B Pump Stand | F Surge Tank Stand | K Hydraulic Return Line; 16 mm (5/8 in.) minimum diameter | Q Hydraulic Pressure Gauge |
| C Fluid Supply Line; 38 mm (1-1/2 in.) minimum diameter | G Surge Tank | L Hydraulic Supply Line; 13 mm (1/2 in.) minimum diameter | R Return Line Shutoff Valve |
| D Fluid Shutoff Valve | H Ground Wire (required; see page 7 for installation) | M Drain Line | S Supply Line Shutoff Valve |
| | | | T Flow Control Valve |
| | | | U Fluid Drain Valve (required) |

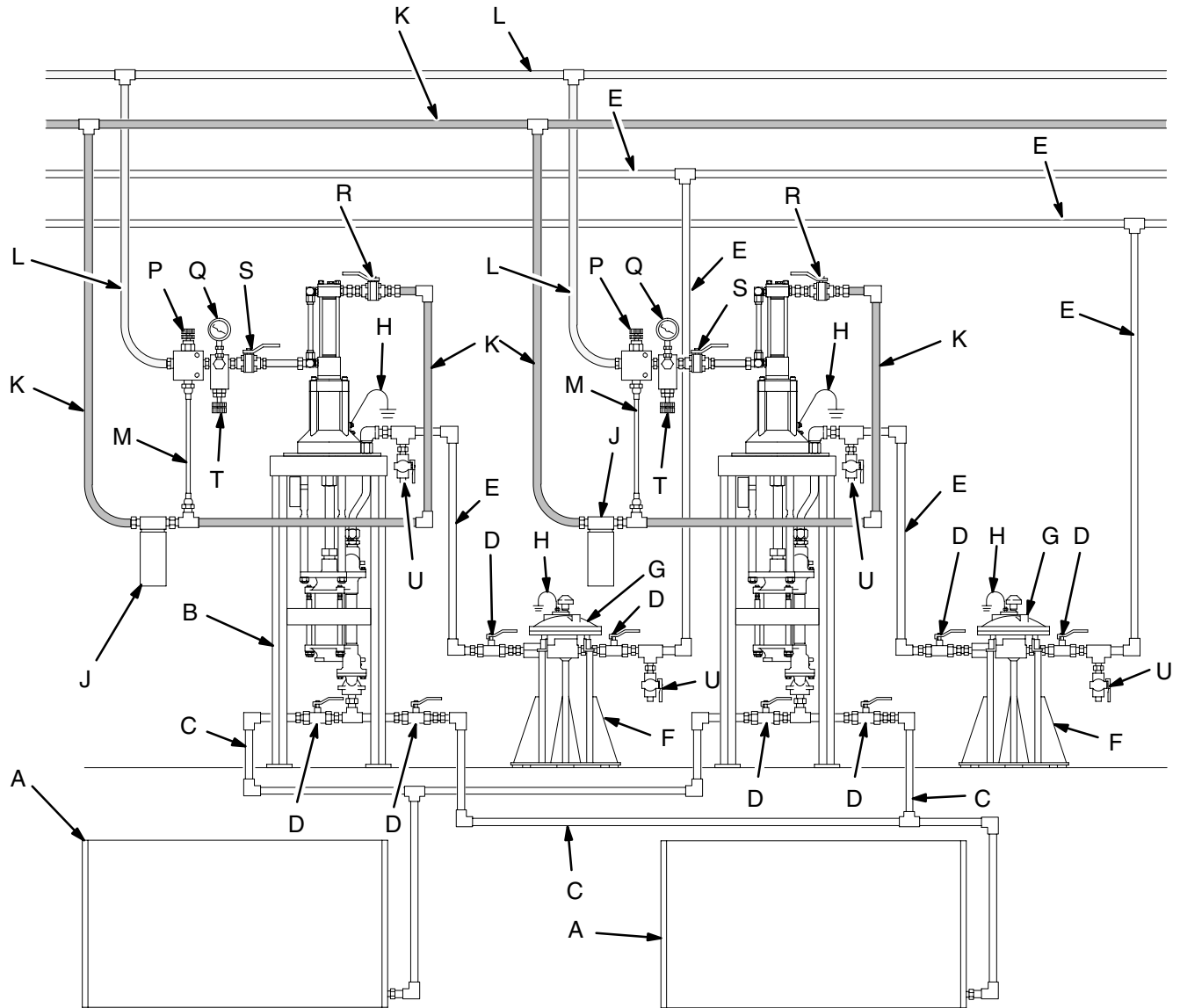

Fig. 5

01924A

Notes

Operation (All Pumps)

Before You Start the Pump

Read and follow all instruction manuals, labels and tags supplied with this pump and with all the accessories you add to the system, before operating the system.

Flush the Pump Before First Use

The pump was tested in lightweight oil. If the oil will contaminate the fluid you are pumping, flush it out with a compatible solvent.

Pressure Relief Procedure

WARNING

PRESSURIZED EQUIPMENT HAZARD

The system pressure must be manually relieved to prevent the system from starting or spraying accidentally. To reduce the risk of an injury from accidental spray from the gun, splashing fluid, or moving parts, follow the **Pressure Relief Procedure** whenever you:

- are instructed to relieve the pressure,
- stop spraying,
- check or service any of the system equipment,
- or install or clean the spray nozzle.

1. Shut off the power to the pump.
2. **In an air-powered system**, close the air regulator (L) and close the bleed-type master air valve (M).
3. **In a hydraulic-powered system**, close the hydraulic supply line shutoff valve (S) first, then the return line shutoff valve (R). In a multi-pump system, do this at each pump to isolate the pumps.
4. Close the fluid shutoff valves from the supply tanks.
5. Trigger the gun at the last gun station to relieve fluid pressure. Maintain firm metal-to-metal contact between the gun and a grounded waste pail. Repeat for all gun stations.
6. Open all drain valves (U) to relieve fluid pressure which may be trapped in the pump or hose.

If you suspect that pressure is not fully relieved after following the steps above, wrap a fitting near the pump outlet with a rag, and slowly and carefully loosen the fitting to relieve pressure. Be careful to protect your eyes from splashing.

Operation (Air-Powered Pumps)

Starting and Adjusting the Pump

1. Charge the surge tank, if you are using one. See the separate instruction manual, 307707.
2. Open all fluid shutoff valves (D).
3. Open the dispensing valve/spray gun at the last gun station and keep it open while starting the pump.
4. Open the bleed-type master air valves (M).
5. Adjust the air regulator (L) to the minimum pressure necessary for the pump to cycle slowly.
6. When fluid is flowing smoothly from the gun, release the gun trigger.
7. One at a time, open any other guns in the system to purge air from the lines.
8. Adjust the pump runaway valve (P) according to the instructions supplied with it.
9. Adjust the lubricator (N) according to the instructions supplied with it.

NOTE: In a circulating system, the pump operates continuously until the power supply is shut off. In a direct supply system, the pump starts when the gun/valve is opened, and stops when the gun/valve is closed.

WARNING

COMPONENT RUPTURE HAZARD



To reduce the risk of overpressurizing your system, which could cause component rupture and serious injury, *never exceed the specified maximum air input pressure to the pump* (see **Technical Data** on pages 50–56).

Shutdown

WARNING

To reduce the risk of serious injury whenever you are instructed to relieve pressure, always follow the **Pressure Relief Procedure** on page 15.

Relieve the pressure.

Operation (Hydraulic-Powered Pumps)

Starting and Adjusting the Pump

1. Charge the surge tank, if you are using one. See the separate instruction manual, 307707.
2. Open all fluid shutoff valves (D).
3. Turn on the hydraulic power supply.
4. Open the flow control valve (T) all the way.
5. Open the return line shutoff valve (R) **first**, then open the supply line shutoff valve (S).
6. Open the dispensing valve/spray gun at the last gun station and keep it open while starting the pump.
7. Adjust the pressure reducing valve (P) until you get the desired fluid pressure.
8. When fluid is flowing smoothly from the gun, release the gun trigger.
9. One at a time, open any other guns in the system to purge air from the lines.
10. With a gun triggered open (dead-end systems only) or with the pump running in a circulating system, count the cycle rate of the pump for one minute. Close the flow control valve (T) until the cycle rate drops to below the desired cycle rate.
11. Open the flow control valve (T) slowly until the cycle rate and fluid pressure return to the desired level. This method of setting the hydraulic controls ensures proper pump operation and prevents pump runaway and damage if the fluid supply runs dry.

12. Release the gun trigger.

NOTE: In a circulating system, the pump operates continuously until the power supply is shut off. In a direct supply system, the pump starts when the gun/valve is opened, and stops when the gun/valve is closed.

WARNING

COMPONENT RUPTURE HAZARD



To reduce the risk of overpressurizing your system, which could cause component rupture and serious injury, *never exceed the specified maximum hydraulic input pressure to the pump* (see **Technical Data** on pages 57–59).

Shutdown

WARNING

To reduce the risk of serious injury whenever you are instructed to relieve pressure, always follow the **Pressure Relief Procedure** on page 15.

Relieve the pressure.

Always shut off the supply line shutoff valve (S) **first**, and then the return line shutoff valve (R). This is to prevent overpressurizing the motor or its seals.

Maintenance

Preventive Maintenance Schedule

The operating conditions of your particular system determine how often maintenance is required. Establish a preventive maintenance schedule by recording when and what kind of maintenance is needed, and then determine a regular schedule for checking your system. Your maintenance schedule should include the following:

Flushing

WARNING



FIRE AND EXPLOSION HAZARD

Before flushing, read the section **FIRE AND EXPLOSION HAZARD** on page 4. Be sure the entire system and flushing pails are properly grounded. Refer to **Grounding** on page 7.

1. Flush before shutting down the system for an extended period of time.
2. Flush before repairing the pump, if possible.
3. Flush before the fluid you are pumping can dry out, settle or set up in the pump and hoses.

Packing Nut Tightness

The packing nut (21) should be tight enough to stop leakage, but no tighter. Overtightening compresses and damages the packings, and may cause the pump to leak, reducing performance. See Fig. 6.

To check the adjustment of the packing nut, first relieve fluid pressure. If you have a torque wrench, tighten the packing nut to 34–40 N•m (25–30 ft–lb).

Excessive Leaking at Throat

If you see excessive leaking at the throat, and tightening the packing nut does not help, replace the throat packings. See page 27.

Senator Pump Shown

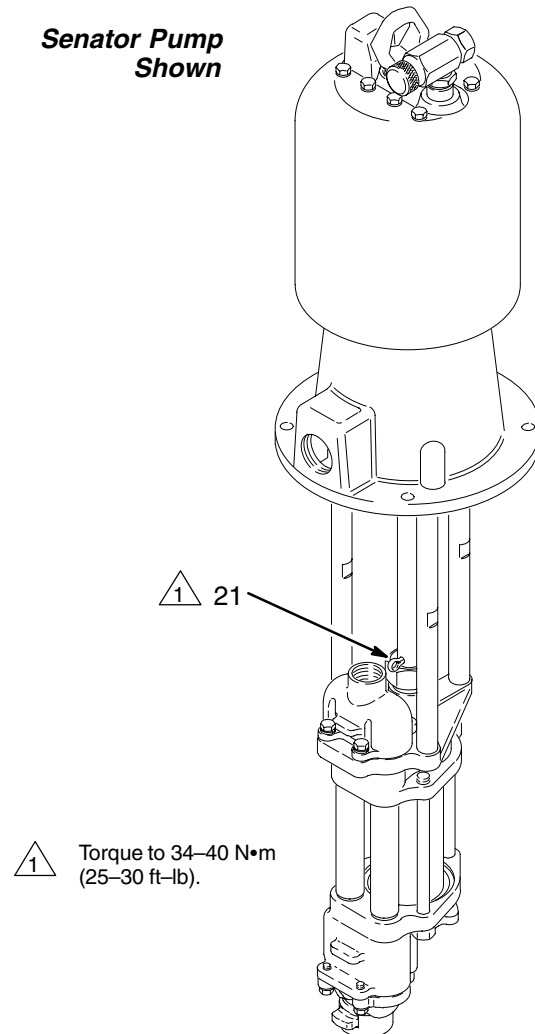

Fig. 6

Maintenance

Air Line Lubricator

Keep properly filled for automatic air motor lubrication.

Air Line Filter

Drain and clean as necessary.

Hydraulic Power Supply Check

Carefully follow the hydraulic power supply manufacturer's recommendations on reservoir and filter cleaning, and periodic changes of hydraulic fluid.

Mix Tank Volume

Don't let the mix tank run dry. When the tank is empty, the pump demands more power as it tries to suck in some fluid. This causes the pump to run too fast, which can seriously damage the pump.

Stop the Pump at the Bottom of Its Stroke

WARNING

To reduce the risk of serious injury whenever you are instructed to relieve pressure, always follow the **Pressure Relief Procedure** on page 15.

Whenever you stop the pump for any reason, relieve the pressure. Stop the pump on the downstroke, before the air motor changes over.

CAUTION

Failure to stop the pump at the bottom of its stroke allows fluid to dry on the piston rod, which can cause damage to the throat packings when the pump is restarted.

Troubleshooting

WARNING

To reduce the risk of serious injury whenever you are instructed to relieve pressure, always follow the **Pressure Relief Procedure** on page 15.

1. Relieve the pressure.
2. Check all possible problems and solutions before disassembling pump.

PROBLEM	CAUSE	SOLUTION
Pump output low on both strokes.	Restricted air or hydraulic supply lines.	Clear any obstructions; be sure all shut-off valves are open; increase pressure, but do not exceed maximum working pressure.
	Exhausted fluid supply.	Refill and reprime pump.
	Clogged fluid outlet line, valves, etc.	Clear.
	Worn piston packing (15).	Replace. See page 27.
Pump output low on only one stroke.	Held open or worn ball check valves.	Check and repair.
	Worn piston packing (15).	Replace. See page 27.
Pump operates erratically.	Exhausted fluid supply.	Refill and reprime pump.
	Held open or worn ball check valves.	Check and repair.
	Worn piston packing (15).	Replace. See page 27.
	Excessive hydraulic fluid supply pressure to Viscount motor.	See Viscount motor manual.
Pump will not operate.	Restricted air or hydraulic supply lines.	Clear any obstructions; be sure all shut-off valves are open; increase pressure, but do not exceed maximum working pressure.
	Exhausted fluid supply.	Refill and reprime pump.
	Clogged fluid outlet line, valves, etc.	Clear.
	Damaged air motor or hydraulic motor.	See motor manual.
	Fluid dried on piston rod (17).	Disassemble and clean pump (see page 27). In future, stop pump at bottom of stroke.
Pump will not prime.	Suction line clogged.	Clear. Flush more frequently.
	Held open or worn ball check valves.	Check and repair.
	Piston assembled with wrong nut.	Use only the large, round, special nut (12).
Excessive throat leakage.	Worn piston rod (17) or throat packings.	Replace. See page 27.

Service

Disconnecting the Displacement Pump

NOTE: To change only the throat packings without removing the displacement pump from the motor, refer to page 25.

If you are doing a complete service of the displacement pump, disconnect it from the motor as described in the applicable procedure on this page, and disassemble the pump as described on page 27.

NOTE: In stand or wall-mounted installations, you do not have to remove the entire pump from its mounting.

WARNING

To reduce the risk of serious injury whenever you are instructed to relieve pressure, always follow the **Pressure Relief Procedure** on page 15.

1. Relieve the pressure.
2. Disconnect the hoses from the displacement pump and plug the ends to prevent fluid contamination.
3. Disconnect the displacement pump from the motor as follows:
 - **For Senator and Bulldog pumps (Fig. 7):** Unscrew the coupling nut (A). Unscrew the locknuts (B) from the tie rods (C). Pull the displacement pump (D) off the motor (E). Remove the pin (F) and screw the coupling (G) off the piston rod (H).
 - **For President (Fig. 8) and Viscount (Fig. 9) pumps:** Unscrew the coupling nut (K) from the piston rod (H). Unscrew the locknuts (B) from the tie rods (C). Pull the displacement pump (D) off the motor (E).

Senator Pump Shown

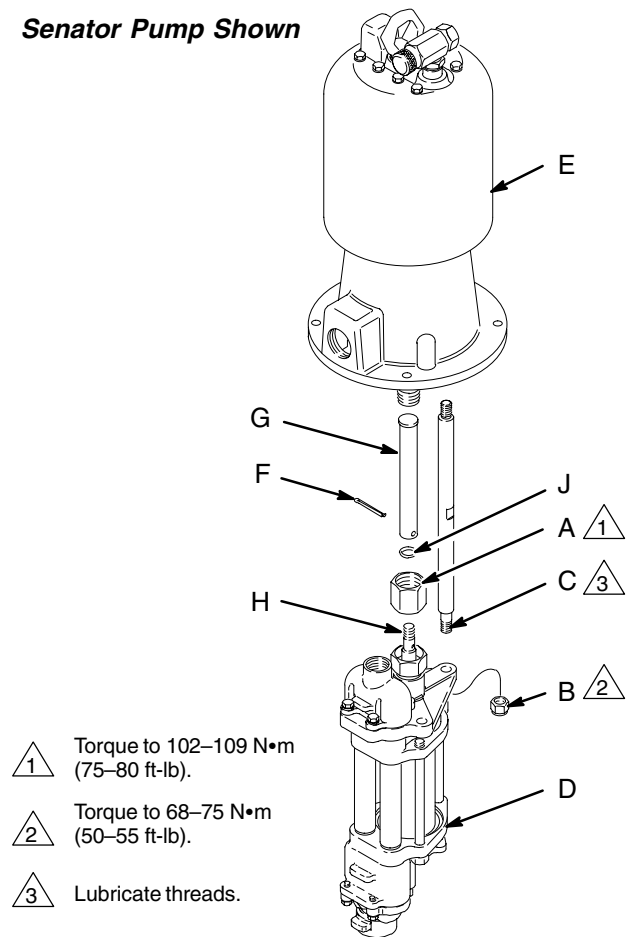

Fig. 7

Reconnecting the Displacement Pump

1. Reconnect the displacement pump to the motor as follows:
 - **For Senator and Bulldog pumps (Fig. 7):** Make sure the coupling nut (A) and o-ring (J) are in place on the coupling (G). Screw the coupling onto the piston rod (H) and install the pin (F). Orient the displacement pump (D) to the motor (E) as shown. Position the displacement pump (D) on the tie rods (C). Lubricate the threads of the tie rods. Screw the locknuts (B) onto the tie rods loosely. Screw the coupling nut (A) onto the motor shaft and torque to 102–109 N•m (75–80 ft-lb). Torque the tie rod locknuts to 68–75 N•m (50–55 ft-lb).

Service

- For President (Fig. 8) and Viscount (Fig. 9) pumps:

NOTE: If the coupling rod (G) and tie rods (C) have been disassembled from a President or Viscount motor, refer to **Reassembling the Coupling Rod and Tie Rods**. If they have not been removed, proceed as follows:

Orient the displacement pump (D) to the motor (E) and adapter plate (L) as shown. Position the displacement pump (D) on the tie rods (C). Lubricate the threads of the tie rods. Screw the locknuts (B) onto the tie rods loosely. Screw the coupling nut (K) onto the piston rod (H) and torque to 102–109 N•m (75–80 ft-lb). Torque the tie rod locknuts to 68–75 N•m (50–55 ft-lb).

2. Flush and test the pump before reinstalling it in the system. Connect hoses for flushing. Flush the pump. While it is pressurized, check for smooth operation and leaks. Adjust or repair as necessary before reinstalling in the system. Reconnect the pump ground wire before operating.

President Pump Shown

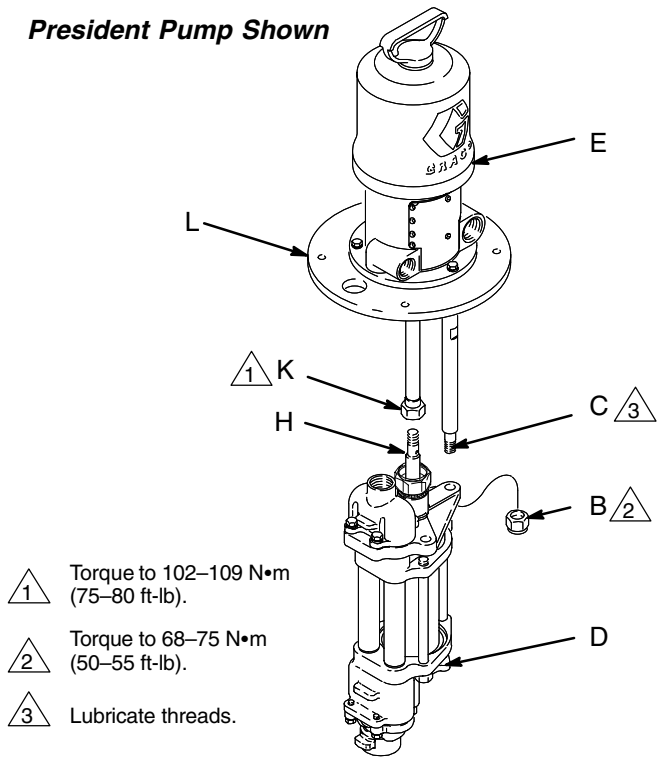

Fig. 8

01927B

Viscount I+ Pump Shown

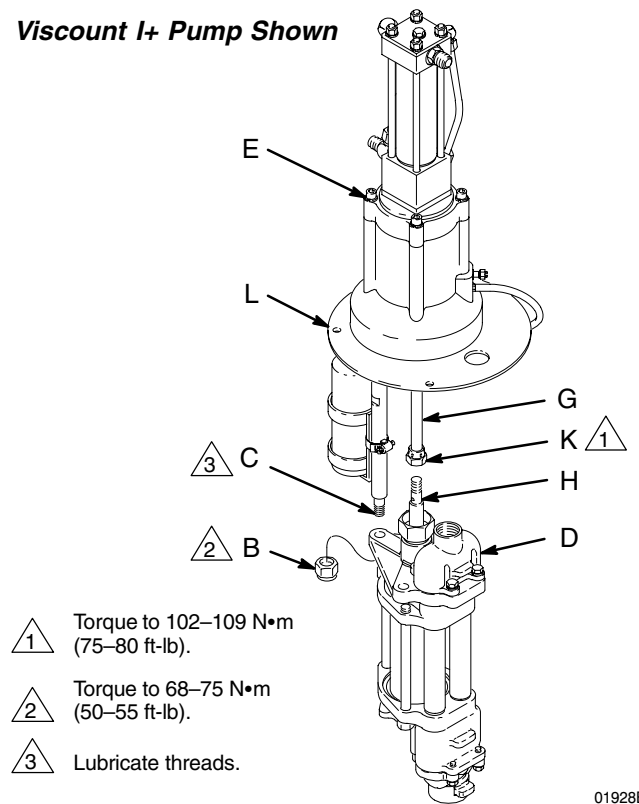

Fig. 9

01928B

Service

Reassembling the Coupling Rod and Tie Rods (President and Viscount only)

NOTE: Use this procedure only if the coupling rod (G) and tie rods (C) have been disassembled from a President or Viscount motor, to ensure proper alignment of the motor shaft to the piston rod.

1. Loosen, but do not remove, the screws (M) holding the adapter plate (L) to the motor (E). See Fig. 10.
2. Screw the tie rods (C) into the adapter plate (L) and torque to 68–75 N•m (50–55 ft-lb).
On Viscount I+ pumps, the tie rods will engage threaded holes in the base of the motor.
3. Fill the cavity in the bottom of the motor shaft with grease. Screw the coupling (G) into the motor shaft until the pin holes align. Install the pin (F) in the **second hole** from the end of the coupling for President pumps, and in the **first hole** from the end of the coupling for Viscount pumps.
4. Align the displacement pump with the tie rods (C) and loosely install the locknuts (B).
5. Screw the coupling nut (K) onto the piston rod (H) and torque to 102–109 N•m (75–80 ft-lb).
6. Torque the screws (M) holding the adapter plate (L) to the motor (E) to 20–23 N•m (15–17 ft-lb). Torque the tie rod locknuts (B) to 68–75 N•m (50–55 ft-lb).

President Pump Shown

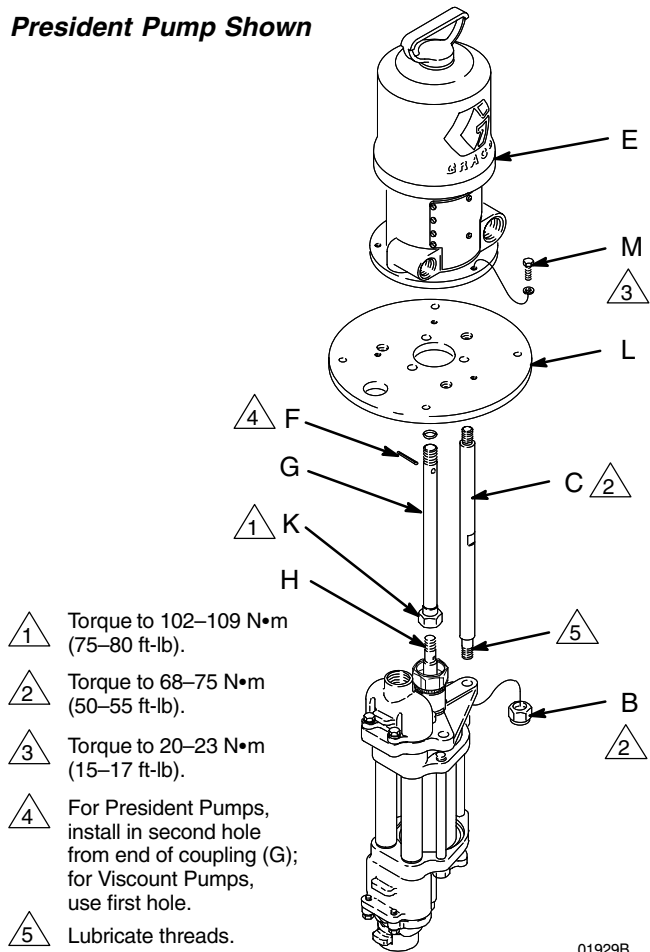

Fig. 10

01929B

Service

Replacing the Throat Packings Without Disconnecting the Displacement Pump

NOTE: To replace the throat packings as part of a complete servicing of the displacement pump, refer to page 27.

NOTE: Throat packing kits are available. Refer to page 45 to order. Parts supplied in the throat packing kit are marked with a symbol, for example (19†). For the best results, use all the parts in the kit.

1. Flush the pump, if possible.
2. Stop the pump at the middle of its stroke.
3. Shut off the air or hydraulic supply.
4. Remove the cotter pin (F). See Fig. 7 for Senator and Bulldog Pumps, and Fig. 10 for President and Viscount Pumps.
5. Cycle the pump slowly to the bottom of its stroke.

WARNING

To reduce the risk of serious injury whenever you are instructed to relieve pressure, always follow the **Pressure Relief Procedure** on page 15.

6. Relieve the pressure.
 7. Uncouple the displacement pump as follows:
 - *Senator and Bulldog Pumps:* See Fig. 7. Unscrew the coupling nut (A) from the motor shaft. Unscrew the coupling (G) from the piston rod (H). Set the coupling and coupling nut aside.
 - *President and Viscount Pumps:* See Figs. 9 and 10. Unscrew the coupling nut (K) from the piston rod (H). Unscrew the coupling rod (G) from the air motor and set it aside.
 8. See Fig. 11. Loosen and remove the packing nut (21).
 9. *Stainless Steel Pumps Only:* Loosen and remove the throat cartridge (38). Remove the PTFE® o-ring (39).
 10. Remove the glands (19, 26) and packings (20, 25).
 11. Lubricate the throat packings and glands. Install one male gland (19†), then five v-packings *with the lips facing down:* one UHMWPE (20†), one leather (25†), UHMWPE, leather, UHMWPE. Install the female gland (26†). Install three v-packings *with the lips facing up:* UHMWPE, leather, UHMWPE. Install the other male gland (19†). Install the packing nut (21) finger-tight.
- NOTE:** Model 239859, 239860, 240612, and 240613 displacement pumps use 8PTFE v-packings (20) in the throat, instead of 5 UHMWPE (20) and 3 leather (25) as on all other models.
12. *Stainless Steel Pumps Only:* Install the o-ring (39†) on the throat cartridge (38), then screw the throat cartridge into the upper pump housing (1). Torque the throat cartridge to 135 N•m (100 ft-lb).
 13. Torque the packing nut (21) to 34–40 N•m (25–30 ft-lb).
 14. Recouple the displacement pump as follows:
 - *Senator and Bulldog Pumps:* See Fig. 7. Make sure the coupling nut (A) and o-ring (J) are in place on the coupling (G). Screw the coupling onto the piston rod (H). Screw the coupling nut (A) onto the motor shaft and torque to 102–109 N•m (75–80 ft-lb).
 - *President and Viscount Pumps:* See Fig. 10. Screw the coupling (G) into the motor shaft until the pin holes align. Screw the coupling nut (K) onto the piston rod (H) and torque to 102–109 N•m (75–80 ft-lb).
 15. Reinstall the pin (F). If necessary, reconnect the air or hydraulic supply and move the pump to the middle of its stroke. Install the pin (F) in the **second hole** from the end of the coupling for President pumps, and in the **first hole** from the end of the coupling for Viscount pumps.

Service

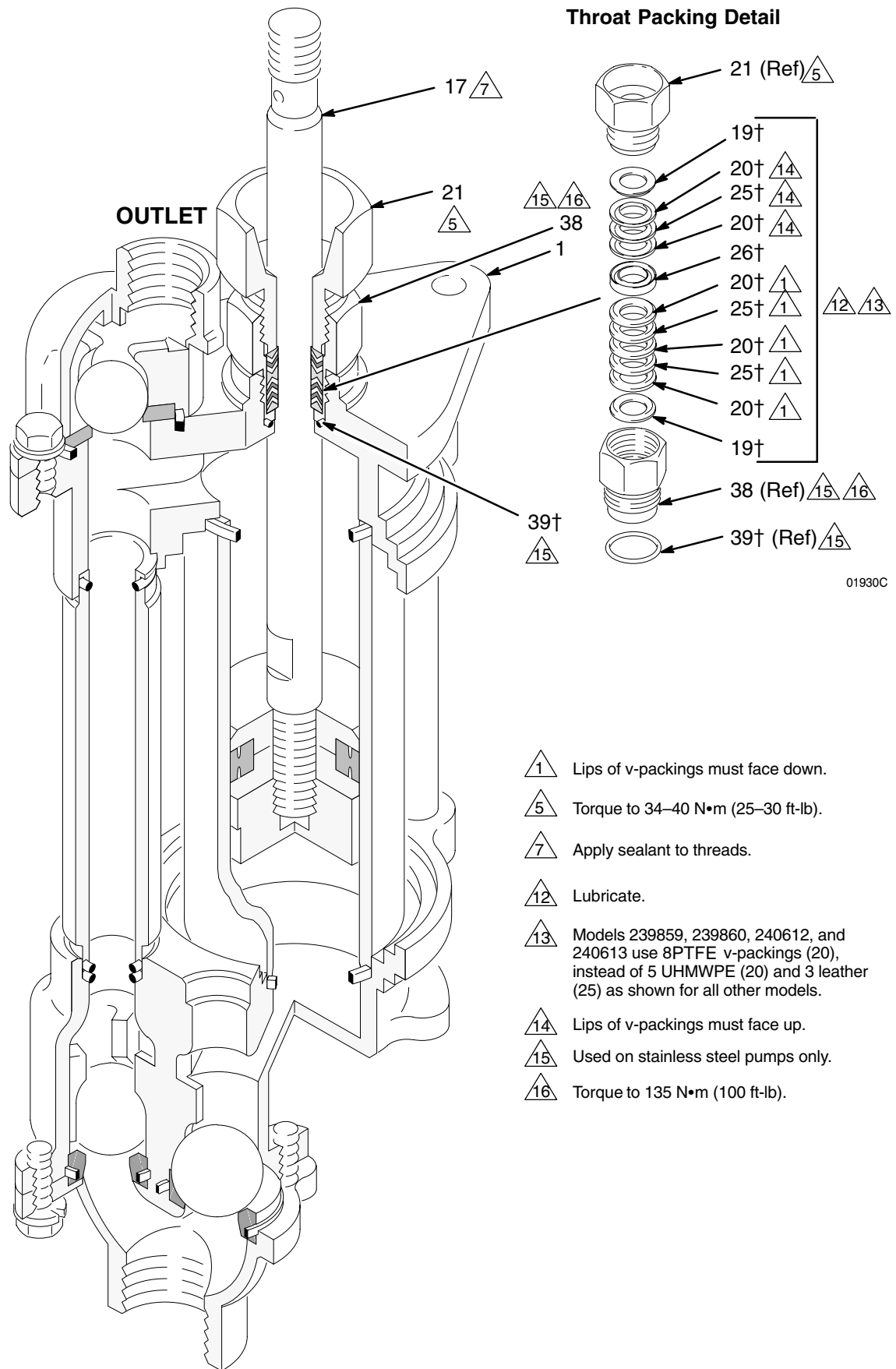

Fig. 11

7522B

Service

Repair Kits

Pump seal kits are available for each pump size. Throat packing kits are also available. Refer to page 45 to order.

Parts supplied in the pump seal kit are marked with one asterisk in the text and drawings, for example (2*). Parts supplied in the throat packing kit are marked with a symbol, for example (19†). For the best results, use all the parts in the kit.

Disassembling the Displacement Pump

1. Remove the pump from the motor as explained on page 22.
 2. Secure the displacement pump intake housing (10) in a vise.
 3. Refer to Fig. 13. Loosen but do not remove the packing nut (21) and the cartridge (38, used on stainless steel pumps only).
 4. Remove the four capscrews (9) and washers (8) from around the pump outlet housing (22).
 5. Remove the outlet housing (22), balls (23), seats (24) and gaskets (7).
 6. Remove the three tie bolts (13) and lockwashers (14). Lift off the upper pump housing (1), along with the fluid tubes (3), cylinder (4), and piston assembly (16).
 7. Remove the packing nut (21). *On stainless steel pumps only*, remove the throat cartridge (38) and o-ring (39).
 8. Remove the glands (19, 26) and packings (20, 25).
- NOTE:** Model 239859, 239860, 240612, and 240613 displacement pumps use 8 PTFE v-packings (20) in the throat, instead of 5 UHMWPE (20) and 3 leather (25) as on all other models.
9. Remove the tubes (3) and cylinder (4) from the housing (1). Pull the piston assembly out of the cylinder.
 10. Remove the intake housing (10) from the vise.
 11. Remove the four capscrews (9) and washers (8) from the intake housing (10). Use a flatblade screwdriver inserted between the lower pump housing (11) and the intake housing (10) to separate them.

NOTE: One intake seat (6) includes a pressure relief valve (V). This seat must be located exactly where shown (the left side as viewed in Fig. 13).

12. Remove the balls (5), intake seats (6 and 34), and gaskets (7).
13. Inspect the pressure relief valve in the seat (6) to make sure it is not clogged. Press down on the valve's ball (B) to see if the ball and the spring (S) are free to move. See Fig. 12.

⚠ CAUTION

If the pressure relief valve in the seat (6) is clogged or filled with material, soak the seat in a compatible solvent. Make sure all material residue is cleaned from the ball and seat area.

If the relief valve cannot be thoroughly cleaned so that the ball and spring are free to move, replace the seat (6).

14. Place the flats of the piston nut (12) in a vise. Unscrew the rod (17) from the nut. Disassemble the piston (16) and remove the seal (15).

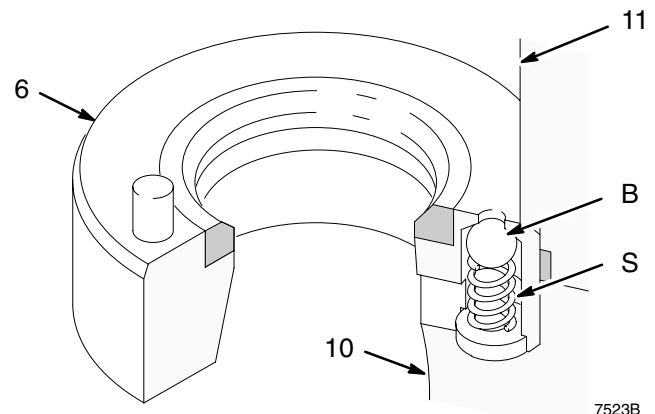

Fig. 12

Cleaning and Inspecting Parts

Clean all parts in a compatible solvent. Inspect all parts for wear or damage. If you are using a repair kit, use all the new parts in the kit, discarding the old ones they replace. Replace any other parts as needed. Worn or damaged parts may cause the pump to perform poorly or cause premature wear of the new seals and packings.

Service

Severe-Duty Electropolished Stainless Steel Pump Shown

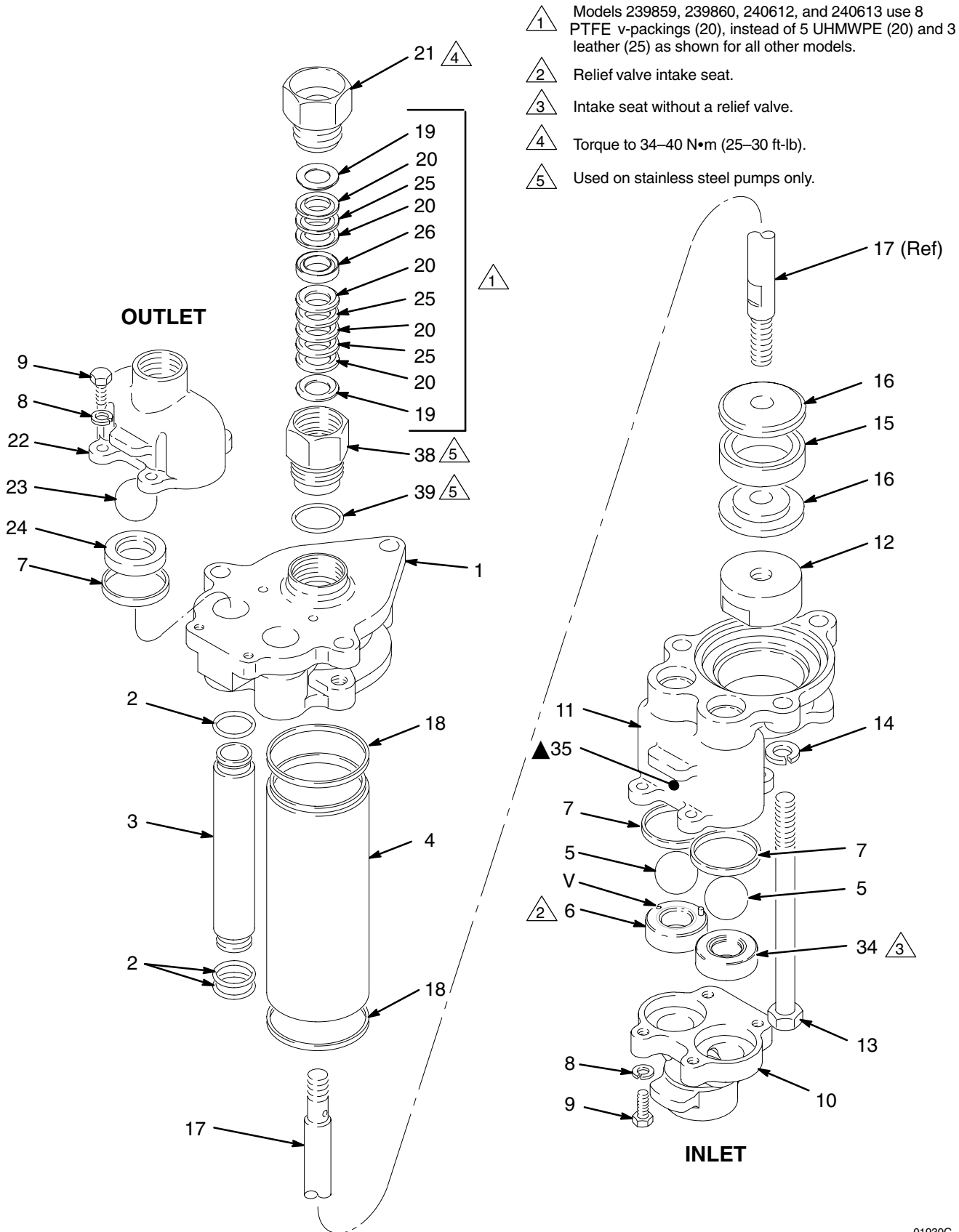

Fig. 13

01930C

Service

Reassembling the Displacement Pump

NOTE: When thread sealant is specified, use low strength (blue) Loctite®.

1. Place the halves of the piston (16) around the packing (15*) and snap them together. See Fig. 15.
2. Apply thread sealant to the piston rod (17) threads. Screw the rod through the piston and packings and into the special piston nut (12). Torque the nut to 68–81 N•m (50–60 ft-lb).
3. With the lower pump housing (11) turned upside down, install the balls (5) and the gaskets (7*).

⚠ WARNING

COMPONENT RUPTURE HAZARD

The relief valve seat (6) **must** be installed at the fluid intake, as shown in Fig. 15. The relief valve relieves pressure trapped in the pump cylinder when the pump is shut off, and reduces the risk of pump overpressurization. The seat cannot relieve pressure if installed in any other position.

4. Install the relief valve intake seat (6) in the left side of the lower housing (11), as viewed in Fig. 15 (the arrow on label 35 points to the correct location). The pin (P) on the seat must point up into the housing. The pin limits the positioning of the seat, ensuring that the vent hole (V) is not blocked by part of the housing. Refer to Fig. 14.
5. Install the intake seat without a relief valve (34) in the right side of the lower housing (11).

NOTE: The seats (6 and 34) are not reversible; the chamfered side must face the ball.

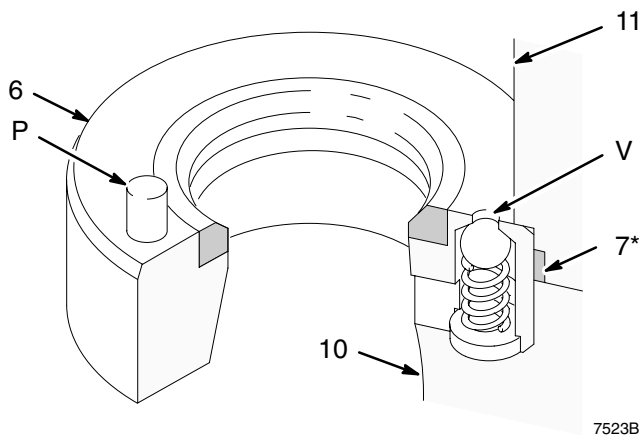

Fig. 14

6. Place the intake housing (10) on the lower pump housing (11). Install the lockwashers (8) and capscrews (9). Torque to 34–40 N•m (25–30 ft-lb). See Fig. 15.
7. Place the intake housing (10) in a vise. Place one o-ring (2*) in each side of the lower pump housing (11), where the tubes (3) sit. Place o-rings (2*) in the grooves at each end of the tubes. Place a gasket (18*) in both the upper and lower housings (1 and 11). Position the tubes and cylinder (4) in the lower housing (11).
8. Lubricate the inside of the cylinder (4). Slide the piston assembly into the cylinder.
9. **On stainless steel pumps**, install the o-ring (39†) on the throat cartridge (38), then screw the throat cartridge into the upper pump housing (1).
10. Lubricate the throat packings and glands. Install one male gland (19†), then five v-packings *with the lips facing down*: one UHMWPE (20†), one leather (25†), UHMWPE, leather, UHMWPE. Install the female gland (26†). Install three v-packings *with the lips facing up*: UHMWPE, leather, UHMWPE. Install the other male gland (19†). Install the packing nut (21) finger-tight.

NOTE: Model 239859, 239860, 240612, and 240613 displacement pumps use 8PTFE v-packings (20) in the throat, instead of 5 UHMWPE (20) and 3 leather (25) as on all other models.

11. Install the upper pump housing (1). It may not seat well on the tubes and cylinder. Install the bolts and lockwashers (14) from the lower pump housing (11). As you tighten the bolts into the upper housing (1), they will draw the housings firmly onto the tubes and cylinders. Tighten the bolts uniformly and torque to 34–40 N•m (25–30 ft-lb).
12. **On stainless steel pumps**, torque the cartridge (38) to 135 N•m (100 ft-lb).
13. Torque the packing nut (21) to 34–40 N•m (25–30 ft-lb).
14. Place a ball (23), seat (24) and gasket (7*) in each side of the outlet housing (22). Install the outlet housing on the upper pump housing (1). Note that the flatter side of the housing faces the **outside** edge of the pump. Install the lockwashers (8) and screws (9), and torque to 34–40 N•m (25–30 ft-lb).
15. Reconnect the displacement pump to the motor as explained on page 22.

Service

Side View of Outlet Housing (22)

Throat Packing Detail

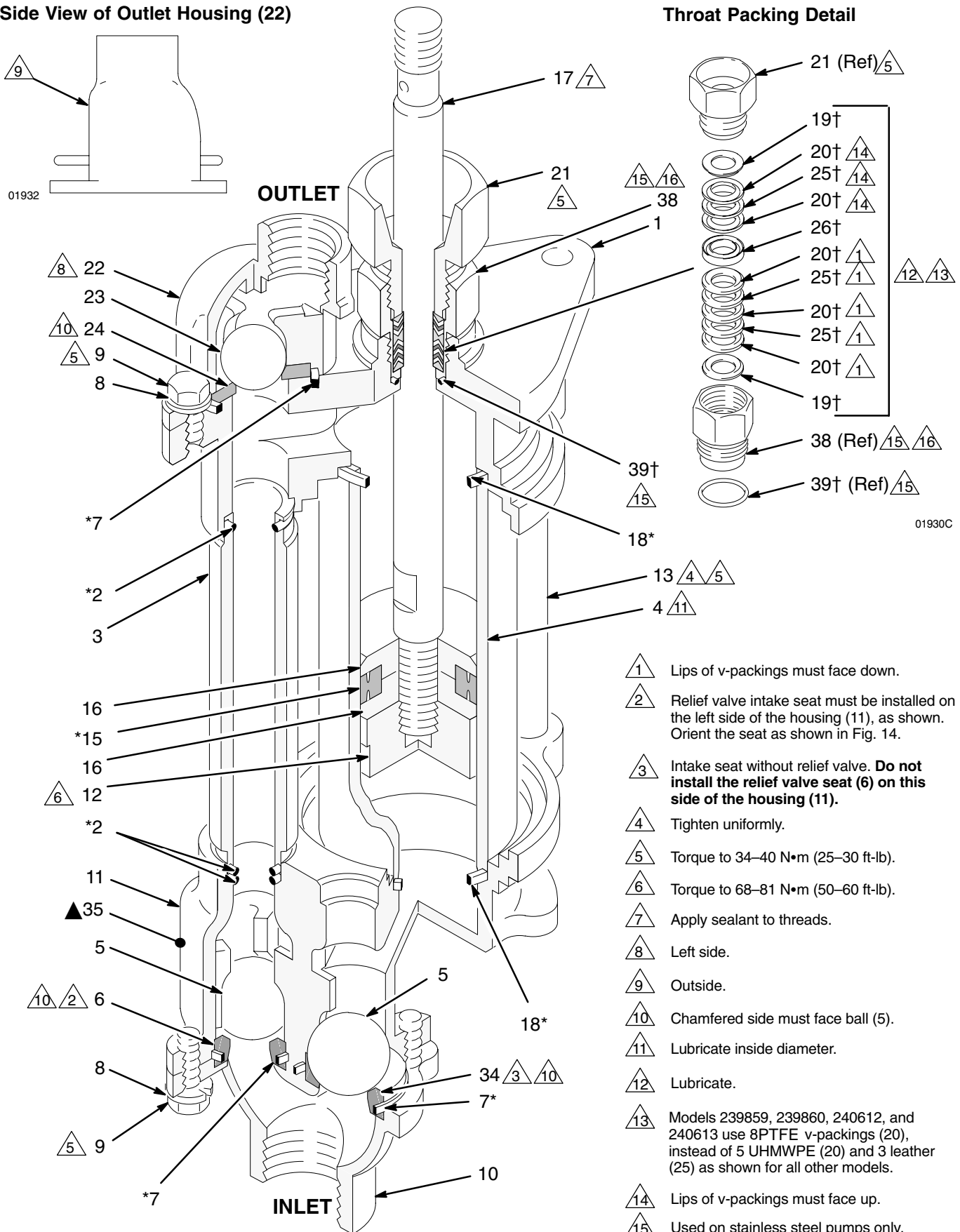

















-  Lips of v-packings must face down.
-  Relief valve intake seat must be installed on the left side of the housing (11), as shown. Orient the seat as shown in Fig. 14.
-  Intake seat without relief valve. **Do not install the relief valve seat (6) on this side of the housing (11).**
-  Tighten uniformly.
-  Torque to 34–40 N•m (25–30 ft-lb).
-  Torque to 68–81 N•m (50–60 ft-lb).
-  Apply sealant to threads.
-  Left side.
-  Outside.
-  Chamfered side must face ball (5).
-  Lubricate inside diameter.
-  Lubricate.
-  Models 239859, 239860, 240612, and 240613 use 8PTFE v-packings (20), instead of 5 UHMWPE (20) and 3 leather (25) as shown for all other models.
-  Lips of v-packings must face up.
-  Used on stainless steel pumps only.
-  Torque to 135 N•m (100 ft-lb).

Fig. 15

7522B

Parts (President Pumps)

CARBON STEEL PUMPS

Model 220560, Series B, 2:1 Ratio

Model 220561, Series B, 3:1 Ratio

Model 237223, Series B, 3:1 Ratio

Model 239855, Series A, 3:1 Ratio, stubby

Ref No.	Part No.	Description	Qty
101	205038	MOTOR, President; see 306982	1
102	183033	ROD, tie; 13.625" (346 mm) between shoulders	3
	192582	ROD, tie; 7.625" (194 mm) between shoulders; used on Model 239855 only	3
103	100103	PIN, cotter; 1/8" dia x 1-1/2"	1
104	156082	PACKING, o-ring; buna-N	1
105	220883	COUPLING	1
	239848	COUPLING; used on Model 239855 only	1
106	100450	CAPSCREW, hex hd; 5/16-18 unc-2a x 1" long	3
107	239834	DISPLACEMENT PUMP for Model 220560; see page 37	1
	239833	DISPLACEMENT PUMP for Models 220561 and 239855; see page 37	1
	239860	DISPLACEMENT PUMP for Model 237223; see page 37	1
108	108527	NUT, lock, hex; 9/16-12 unc	3
113	100214	LOCKWASHER; 0.318"	3
114	186071	PLATE, adapter	1
115	183351	LABEL, ID (not shown)	1

SEVERE-DUTY, ELECTROPOLISHED STAINLESS STEEL PUMPS

Model 220562, Series C, 1.5:1 Ratio

Model 220563, Series C, 2:1 Ratio

Model 220564, Series C, 3:1 Ratio

Model 237222, Series C, 3:1 Ratio

Model 239854, Series B, 3:1 Ratio, stubby

Model 240618, Series A, 3:1 Ratio, with bsp threads and tri-clamp adapters

Model 240619, Series A, 3:1 Ratio, with bsp threads, without tri-clamp adapters

Ref No.	Part No.	Description	Qty
101	205038	MOTOR, President; see 306982	1
102	183089	ROD, tie; 13.625" (346 mm) between shoulders	3
	192582	ROD, tie; 7.625" (194 mm) between shoulders; used on Model 239854 only	3
103	101946	PIN, cotter; 1/8" dia x 1-1/2"	1
104	156082	PACKING, o-ring; buna-N	1
105	220883	COUPLING	1
	239848	COUPLING; used on Model 239854 only	1
106	100450	CAPSCREW, hex hd; 5/16-18 unc-2a x 1" long	3
107	239838	DISPLACEMENT PUMP for Model 220562; see page 39	1
	239837	DISPLACEMENT PUMP for Model 220563; see page 39	1
	239836	DISPLACEMENT PUMP for Models 220564 and 239854; see page 39	1
	239859	DISPLACEMENT PUMP for Model 237222; see page 39	1
	240610	DISPLACEMENT PUMP, with tri-clamp adapters, for Model 240618; see page 41	1
	240611	DISPLACEMENT PUMP, without tri-clamp adapters, for Model 240619; see page 41	1
108	108683	NUT, lock, hex; 9/16-12 unc	3
113	100214	LOCKWASHER; 0.318"	3
114	186071	PLATE, adapter	1
115	183351	LABEL, ID (not shown)	1

Parts (President Pumps)

CARBON STEEL PUMPS

Model 220560, Series B, 2:1 Ratio

Model 220561, Series B, 3:1 Ratio

Model 237223, Series B, 3:1 Ratio

Model 239855, Series A, 3:1 Ratio, stubby

SEVERE-DUTY, ELECTROPOLISHED STAINLESS STEEL PUMPS

Model 220562, Series C, 1.5:1 Ratio

Model 220563, Series C, 2:1 Ratio

Model 220564, Series C, 3:1 Ratio

Model 237222, Series C, 3:1 Ratio

Model 239854, Series B, 3:1 Ratio, stubby

Model 240618, Series A, 3:1 Ratio, with bsp threads and tri-clamp adapters

Model 240619, Series A, 3:1 Ratio, with bsp threads, without tri-clamp adapters

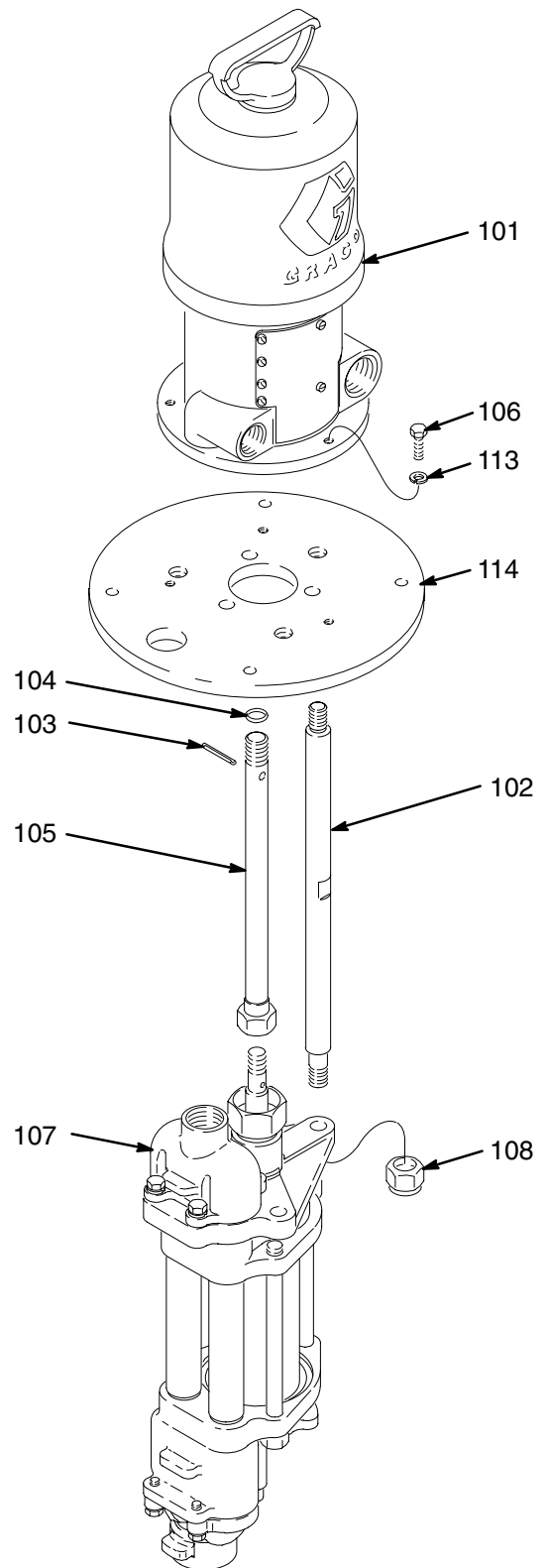

01929B

Parts (Quiet Senator Pumps)

CARBON STEEL PUMPS

Model 220565, Series B, 3.5:1 Ratio

Model 220567, Series B, 2.5:1 Ratio

Ref No.	Part No.	Description	Qty
101	220571	MOTOR, Quiet Senator See 307592 for parts	1
102	183033	ROD, tie; 13.625" (346 mm) between shoulders	3
103	100103	PIN, cotter; 1/8" dia x 1-1/2"	1
104	108284	PACKING, o-ring; buna-N	1
105	183041	COUPLING	1
106	183042	NUT, coupling	1
107	239834	DISPLACEMENT PUMP Used on Model 220565 See separate parts list on page 37	1
	239835	DISPLACEMENT PUMP Used on Model 220567 See separate parts list on page 37	1
108	108527	NUT, lock, hex; 9/16-12 unc	3
113	181096	LABEL, ID (not shown)	1

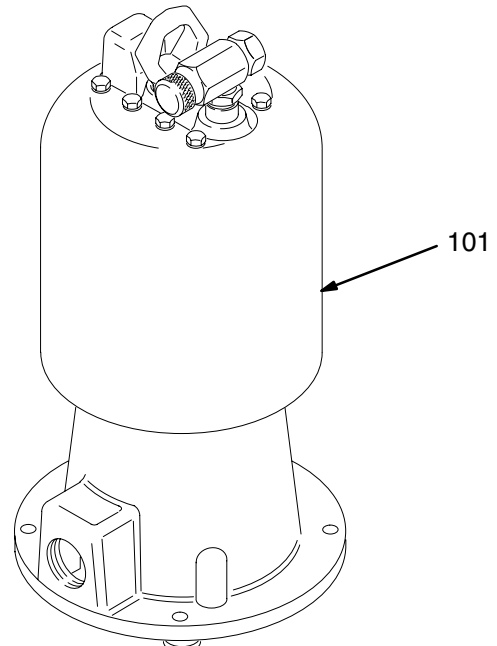

SEVERE-DUTY, ELECTROPOLISHED STAINLESS STEEL PUMPS

Model 220568, Series C, 3.5:1 Ratio

Model 220570, Series C, 2.5:1 Ratio

Ref No.	Part No.	Description	Qty
101	220571	MOTOR, Quiet Senator See 307592 for parts	1
102	183089	ROD, tie; 13.625" (346 mm) between shoulders	3
103	101946	PIN, cotter; 1/8" dia x 1-1/2"	1
104	108284	PACKING, o-ring; buna-N	1
105	183084	COUPLING	1
106	183079	NUT, coupling	1
107	239837	DISPLACEMENT PUMP Used on Model 220568 See separate parts list on page 39	1
	239838	DISPLACEMENT PUMP Used on Model 220570 See separate parts list on page 39	1
108	108683	NUT, lock, hex; 9/16-12 unc	3
113	181096	LABEL, ID (not shown)	1

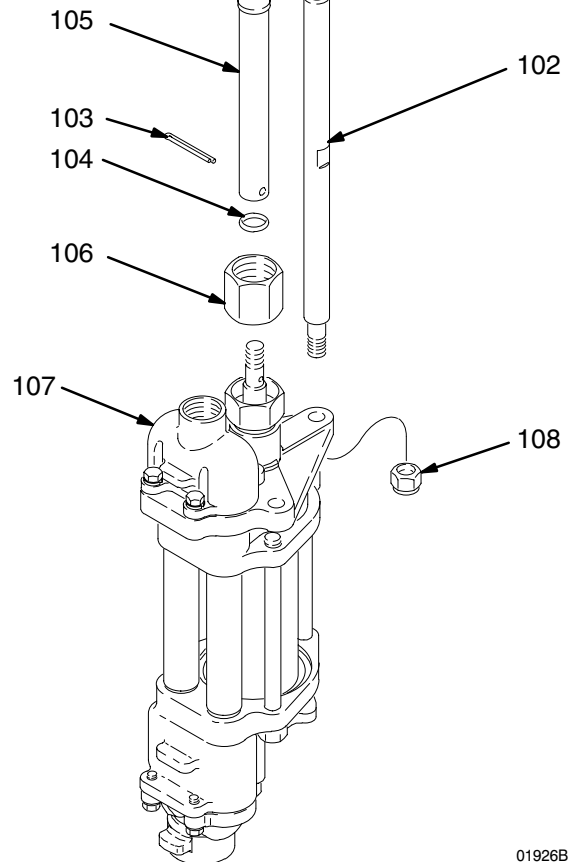

01926B

Parts (Quiet Bulldog Pumps)

CARBON STEEL PUMPS

113 181096 LABEL, ID (not shown)

1

Model 220577, Series B, 4:1 Ratio

Ref No.	Part No.	Description	Qty
101	215255	MOTOR, Quiet Bulldog See 307304 for parts	1
102	183033	ROD, tie; 13.625" (346 mm) between shoulders	3
103	100103	PIN, cotter; 1/8" dia x 1-1/2"	1
104	108284	PACKING, o-ring; buna-N	1
105	183041	COUPLING	1
106	183042	NUT, coupling	1
107	239835	DISPLACEMENT PUMP, for Model 220577; See separate parts list on page 37	1
108	108527	NUT, lock, hex; 9/16-12 unc	3
113	181096	LABEL, ID (not shown)	1

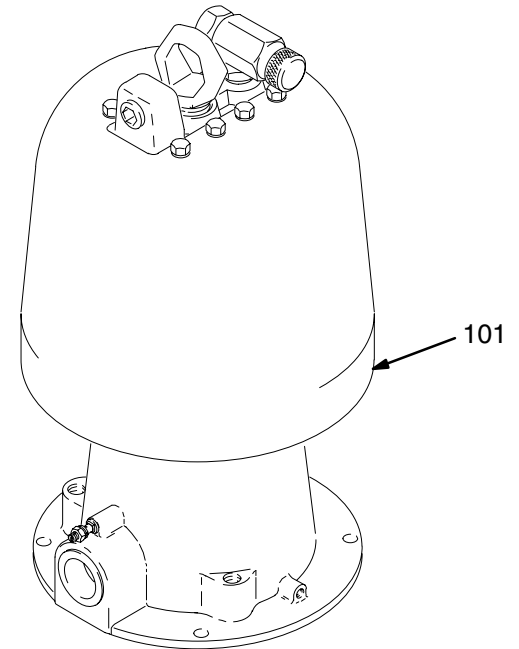

SEVERE-DUTY, ELECTROPOLISHED STAINLESS STEEL PUMPS

Model 220578, Series C, 4:1 Ratio

Model 240625, Series A, 4:1 Ratio, with bsp threads and tri-clamp adapters

Model 240626, Series A, 4:1 Ratio, with bsp threads, without tri-clamp adapters

Ref No.	Part No.	Description	Qty
101	215255	MOTOR, Quiet Bulldog (used on 220578) See 307304 for parts	1
	233077	MOTOR, Quiet Bulldog (used on 240625 and 240626) See 307304 for parts	1
102	183089	ROD, tie; 13.625" (346 mm) between shoulders	3
103	101946	PIN, cotter; 1/8" dia x 1-1/2"	1
104	108284	PACKING, o-ring; buna-N	1
105	183084	COUPLING	1
106	183079	NUT, coupling	1
107	239838	DISPLACEMENT PUMP, for Model 220578; See separate parts list on page 39	1
	240606	DISPLACEMENT PUMP, with tri-clamp adapters, for Model 240625; See separate parts list on page 41	1
	240607	DISPLACEMENT PUMP, without tri-clamp adapters, for Model 240626; See separate parts list on page 41	1
108	108683	NUT, lock, hex; 9/16-12 unc	3

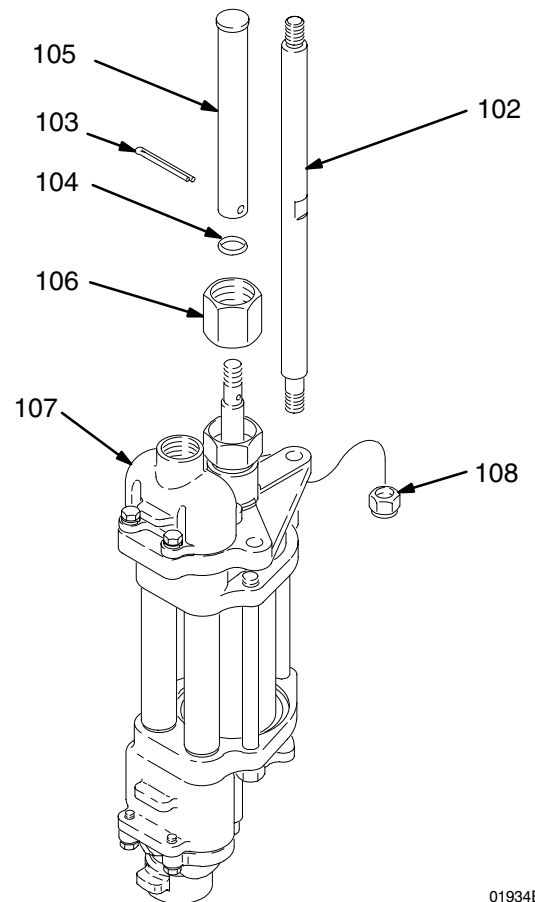

01934B

Parts (Viscount I+ Pumps)

CARBON STEEL PUMPS

Model 236601, Series B, Model 236605, Series B, Model 236712, Series B

Ref No.	Part No.	Description	Qty
101	236417	MOTOR, hydraulic, Viscount I+ See 308330 for parts	1
102	183033	ROD, tie; 13.625" (346 mm) between shoulders	3
103	100103	PIN, cotter; 1/8" dia x 1-1/2"	1
104	156082	PACKING, o-ring; buna-N	1
105	220883	COUPLING	1
107	239834	DISPLACEMENT PUMP Used on Model 236605 See separate parts list on page 37	1
	239833	DISPLACEMENT PUMP Used on Model 236601 See separate parts list on page 37	1
	239835	DISPLACEMENT PUMP Used on Model 236712 See separate parts list on page 37	1
108	108527	NUT, lock, hex; 9/16-12 unc	3
112	100001	SCREW, cap, hex hd; 5/16-18 unc-2a x 0.625 in. (16 mm)	4
113	100214	LOCKWASHER; 0.318"	4
114	189206	PLATE, adapter	1

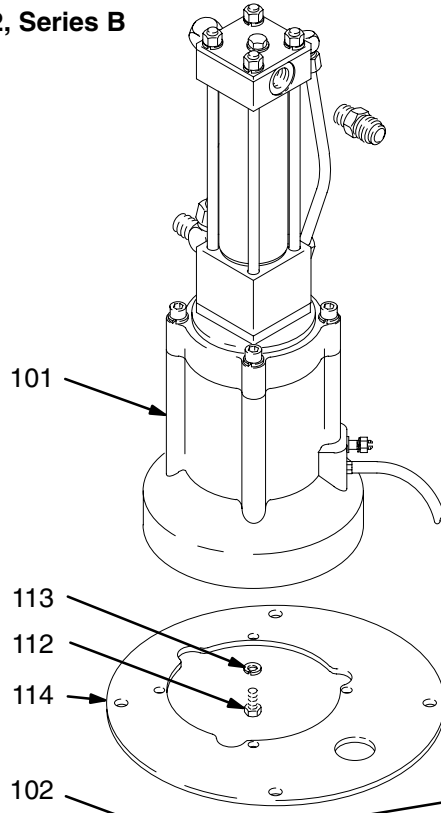

SEVERE-DUTY, ELECTROPOLISHED STAINLESS STEEL PUMPS

Model 236602, Series C, Model 236606, Series C
Model 236713, Series C, Model 244142, Series A

Ref No.	Part No.	Description	Qty
101	236417	MOTOR, hydraulic, Viscount I+ See 308330 for parts	1
102	183089	ROD, tie; 13.625" (346 mm) between shoulders	3
103	101946	PIN, cotter; 1/8" dia x 1-1/2"	1
104	156082	PACKING, o-ring; buna-N	1
105	220883	COUPLING	1
107	239837	DISPLACEMENT PUMP Used on Model 236606 See separate parts list on page 39	1
	239836	DISPLACEMENT PUMP Used on Model 236602 See separate parts list on page 39	1
	239838	DISPLACEMENT PUMP Used on Model 236713 See separate parts list on page 39	1
	239859	DISPLACEMENT PUMP Used on 244142 See separate parts list on page 39	1
108	108683	NUT, lock, hex; 9/16-12 unc	3
112	100001	SCREW, cap, hex hd; 5/16-18 unc-2a x 0.625 in. (16 mm)	4
113	100214	LOCKWASHER; 0.318"	4
114	189206	PLATE, adapter	1

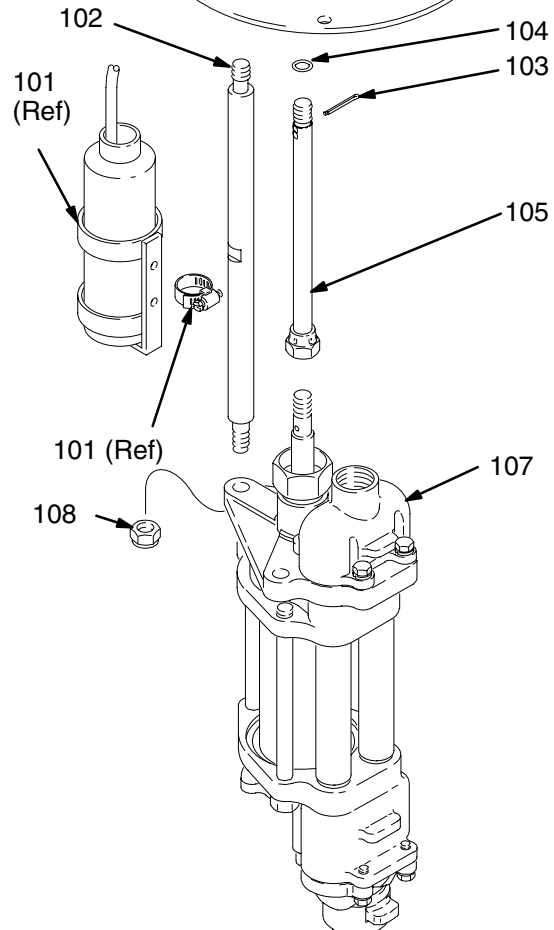

03248B

Displacement Pump Parts

CARBON STEEL DISPLACEMENT PUMPS

Model 239833, Series A; for Pump Models 220561, 236601, and 239855

Model 239834, Series A; for Pump Models 220560, 220565, and 236605

Model 239835, Series A; for Pump Models 220567, 220577, and 236712

Model 239860, Series A; for Pump Model 237223

NOTE: Part numbers vary by pump. To find the part number used in your pump, read down the chart to find the desired ref. no., then read left to right to find the part number for your pump.

Ref. No.	Description	Displacement Pump Part Numbers				Qty
		239833	239834	239835	239860	
1	HOUSING, pump, upper; ductile iron	192751	192751	192751	192751	1
2*	PACKING, o-ring; PTFE®	108526	108526	108526	108526	6
3	TUBE, fluid; sst	183085	183085	183085	183085	2
4	CYLINDER, pump; cst	181899	183032	181900	181899	1
5	BALL, intake; 1.25" diameter; sst	101968	101968	101968	101968	2
6	SEAT, intake valve, with relief valve; sst	239805	239805	239805	239805	1
7*	GASKET, seat, valve; UHMWPE	181877	181877	181877	181877	4
8	WASHER, flat; 8.4 mm; sst	111003	111003	111003	111003	8
9	CAPSCREW, hex hd; M8 x 1.25 x 25; cst	107558	107558	107558	107558	8
10	HOUSING, intake; ductile iron	192260	192260	192260	192260	1
11	HOUSING, pump, lower; ductile iron	181730	181730	181730	181730	1
12	NUT, piston; sst	108528	108528	108528	108528	1
13	CAPSCREW, hex hd; 9/16–12 unc x 7.75" long; cst	108524	108524	108524	108524	3
14	LOCKWASHER, spring; 9/16"; cst	101333	101333	101333	101333	3
15*	PACKING, piston; UHMWPE	181680	183039	181793		1
	PACKING, piston; PTFE				187761	1
16	PISTON; cst	181685	183040	181792	181685	2
17	ROD, piston; sst	181898	181898	181898	181898	1
18*	GASKET, cylinder; UHMWPE	181875	183094	181876	181875	2
19†	GLAND, male; sst	192263	192263	192263	192263	2
20†	V-PACKING, throat; UHMWPE	183295	183295	183295		5
	V-PACKING, throat; PTFE				183352	8
21	NUT, packing; sst	181684	181684	181684	181684	1
22	HOUSING, outlet; ductile iron	181728	181728	181728	181728	1
23	BALL, outlet; 1" (25 mm) diameter; sst	110259	110259	110259	110259	2
24	SEAT, valve; sst	183095	183095	183095	183095	2
25†	V-PACKING, throat; leather	183294	183294	183294		3
26†	GLAND, female; sst	192264	192264	192264	192264	1
34	SEAT, intake valve; sst	239865	239865	239865	239865	1
35▲	PLATE, warning	290537	290537	290537	290537	1
36	SCREW, drive, type U; 3/16" long	100508	100508	100508	100508	2
37▲	TAG, warning (not shown)	172479	172479	172479	172479	1

* These parts are included in the Seal Repair Kit, which may be purchased separately. Refer to page 45.

† These parts are included in the Throat Packing Repair Kit, which may be purchased separately. Refer to page 45.

▲ Replacement Danger and Warning labels, tags and cards are available at no cost.

Displacement Pump Parts

CARBON STEEL DISPLACEMENT PUMPS

Model 239833, Series A; for Pump Models 220561, 236601, and 239855

Model 239834, Series A; for Pump Models 220560, 220565, and 236605

Model 239835, Series A; for Pump Models 220567, 220577, and 236712

Model 239860, Series A; for Pump Model 237223

NOTE: See Service Section for important assembly procedures, torque notes, and sealants.

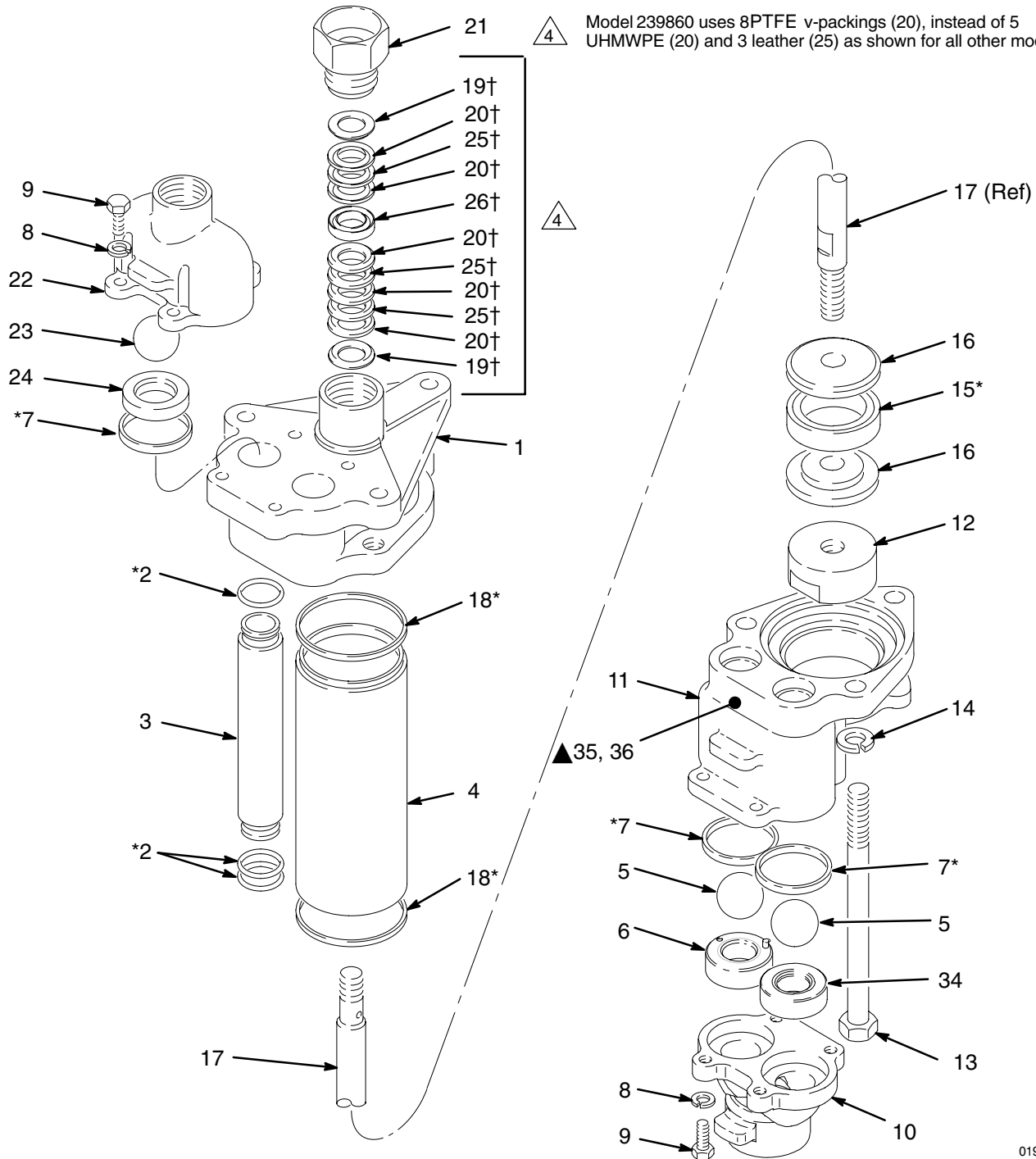

01936B

Displacement Pump Parts

SEVERE-DUTY ELECTROPOLISHED STAINLESS STEEL DISPLACEMENT PUMPS

Model 239836, Series B; for Pump Models 220564, 236602, and 239854

Model 239837, Series B; for Pump Models 220563, 220568, and 236606

Model 239838, Series B; for Pump Models 220562, 220570, 220578, and 236713

Model 239859, Series B; for Pump Model 237222, 244142

NOTE: Part numbers vary by pump. To find the part number used in your pump, read down the chart to find the desired ref. no., then read left to right to find the part number for your pump.

Ref. No.	Description	Displacement Pump Part Numbers				Qty
		239836	239837	239838	239859	
1	HOUSING, pump, upper; sst	192512	192512	192512	192512	1
2*	PACKING, o-ring; PTFE®	108526	108526	108526	108526	6
3	TUBE, fluid; sst	183085	183085	183085	183085	2
4	CYLINDER, pump; sst	183049	183047	183048	183049	1
5	BALL, intake; 1.25" diameter; sst	101968	101968	101968	101968	2
6	SEAT, intake valve, with relief valve; sst	239805	239805	239805	239805	1
7*	GASKET, seat, valve; UHMWPE	181877	181877	181877	181877	4
8	WASHER, flat; 8.4 mm; sst	111003	111003	111003	111003	8
9	CAPSCREW, hex hd; M8 x 1.25 x 25; sst	112084	112084	112084	112084	8
10	HOUSING, intake; sst	192259	192259	192259	192259	1
11	HOUSING, pump, lower; sst	181905	181905	181905	181905	1
12	NUT, piston; sst	108528	108528	108528	108528	1
13	CAPSCREW, hex hd; 9/16–12 unc x 7.75" long; sst	108523	108523	108523	108523	3
14	LOCKWASHER, spring; 9/16"; sst	108525	108525	108525	108525	3
15*	PACKING, piston; UHMWPE	181680	183039	181793		1
	PACKING, piston; PTFE				187761	1
16	PISTON; sst	183081	183082	183083	183081	2
17	ROD, piston; sst	181898	181898	181898	181898	1
18*	GASKET, cylinder; UHMWPE	181875	183094	181876	181875	2
19†	GLAND, male; sst	192263	192263	192263	192263	2
20†	V-PACKING, throat; UHMWPE	183295	183295	183295		5
	V-PACKING, throat; PTFE				183352	8
21	NUT, packing; sst	181684	181684	181684	181684	1
22	HOUSING, outlet; sst	188104	188104	188104	188104	1
23	BALL, outlet; 1" (25 mm) diameter; sst	110259	110259	110259	110259	2
24	SEAT, valve; sst	183095	183095	183095	183095	2
25†	V-PACKING, throat; leather	183294	183294	183294		3
26†	GLAND, female; sst	192264	192264	192264	192264	1
34	SEAT, intake valve; sst	239865	239865	239865	239865	1
35▲	PLATE, warning	290537	290537	290537	290537	1
36	SCREW, drive, type U; 3/16" long	103972	103972	103972	103972	2
37▲	TAG, warning (not shown)	172479	172479	172479	172479	1
38	CARTRIDGE, throat; sst	192490	192490	192490	192490	1
39†	O-RING; PTFE	107313	107313	107313	107313	1

* These parts are included in the Seal Repair Kit, which may be purchased separately. Refer to page 45.

† These parts are included in the Throat Packing Repair Kit, which may be purchased separately. Refer to page 45.

▲ Replacement Danger and Warning labels, tags and cards are available at no cost.

Displacement Pump Parts

SEVERE-DUTY ELECTROPOLISHED STAINLESS STEEL DISPLACEMENT PUMPS

Model 239836, Series B; for Pump Models 220564, 236602, and 239854

Model 239837, Series B; for Pump Models 220563, 220568, and 236606

Model 239838, Series B; for Pump Models 220562, 220570, 220578, and 236713

Model 239859, Series B; for Pump Model 237222

NOTE: See Service Section for important assembly procedures, torque notes, and sealants.

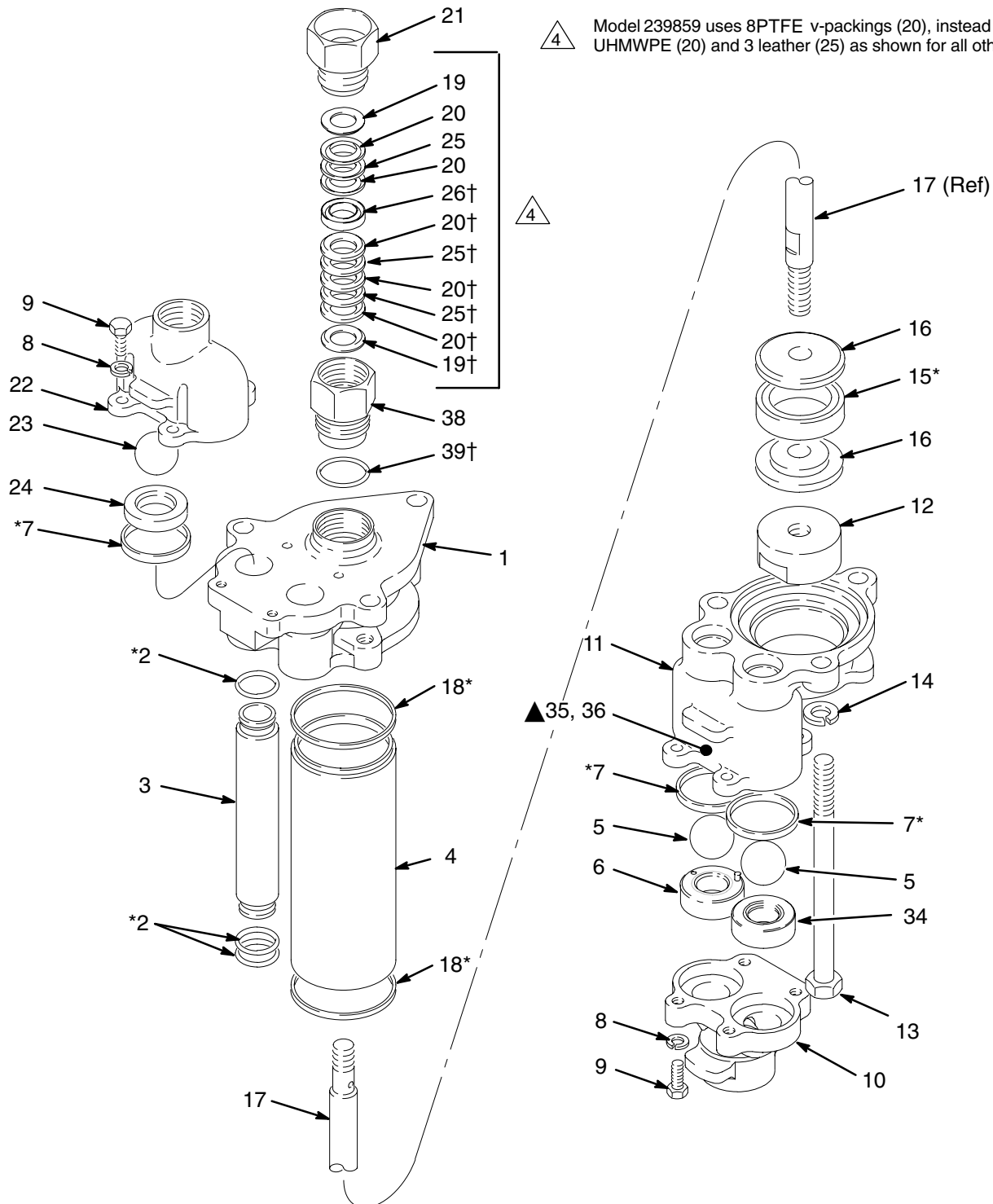

Displacement Pump Parts

SEVERE-DUTY ELECTROPOLISHED STAINLESS STEEL DISPLACEMENT PUMPS, WITH BSP THREADS

Model 240606, Series A, with tri-clamp adapters; for Pump Model 240625

Model 240607, Series A, without tri-clamp adapters; for Pump Model 240626

Model 240610, Series A, with tri-clamp adapters; for Pump Model 240618

Model 240611, Series A, without tri-clamp adapters; for Pump Model 240619

NOTE: Part numbers vary by pump. To find the part number used in your pump, read down the chart to find the desired ref. no., then read left to right to find the part number for your pump.

Ref. No.	Description	Displacement Pump Part Numbers				Qty
		240606	240607	240610	240611	
1	HOUSING, pump, upper; sst	192512	192512	192512	192512	1
2*	PACKING, o-ring; PTFE [®]	108526	108526	108526	108526	6
3	TUBE, fluid; sst	183085	183085	183085	183085	2
4	CYLINDER, pump; sst	183048	183048	183049	183049	1
5	BALL, intake; 1.25" diameter; sst	101968	101968	101968	101968	2
6	SEAT, intake valve, with relief valve; sst	239805	239805	239805	239805	1
7*	GASKET, seat, valve; UHMWPE	181877	181877	181877	181877	4
8	WASHER, flat; 8.4 mm; sst	111003	111003	111003	111003	8
9	CAPSCREW, hex hd; M8 x 1.25 x 25; sst	112084	112084	112084	112084	8
10	HOUSING, intake; sst	193205	193205	193205	193205	1
11	HOUSING, pump, lower; sst	181905	181905	181905	181905	1
12	NUT, piston; sst	108528	108528	108528	108528	1
13	CAPSCREW, hex hd; 9/16–12 unc x 7.75" long; sst	108523	108523	108523	108523	3
14	LOCKWASHER, spring; 9/16"; sst	108525	108525	108525	108525	3
15*	PACKING, piston; UHMWPE	181793	181793	181680	181680	1
16	PISTON; sst	183083	183083	183081	183081	2
17	ROD, piston; sst	181898	181898	181898	181898	1
18*	GASKET, cylinder; UHMWPE	181876	181876	181875	181875	2
19†	GLAND, male; sst	192263	192263	192263	192263	2
20†	V-PACKING, throat; UHMWPE	183295	183295	183295	183295	5
21	NUT, packing; sst	181684	181684	181684	181684	1
22	HOUSING, outlet; sst	193204	193204	193204	193204	1
23	BALL, outlet; 1" (25 mm) diameter; sst	110259	110259	110259	110259	2
24	SEAT, valve; sst	183095	183095	183095	183095	2
25†	V-PACKING, throat; leather	183294	183294	183294	183294	3
26†	GLAND, female; sst	192264	192264	192264	192264	1
34	SEAT, intake valve; sst	239865	239865	239865	239865	1
35▲	PLATE, warning	290537	290537	290537	290537	1
36	SCREW, drive, type U; 3/16" long	103972	103972	103972	103972	2
37▲	TAG, warning (not shown)	172479	172479	172479	172479	1
38	CARTRIDGE, throat; sst	192490	192490	192490	192490	1
39†	O-RING; PTFE	107313	107313	107313	107313	1
40	ADAPTER, tri-clamp; fluid outlet	193427		193427		1
41	SEAL; PTFE 1–1/4 in. (32 mm) ID	193422		193422		1
42	ADAPTER, tri-clamp; fluid inlet	193426		193426		1
43	SEAL; PTFE 1–1/2 in. (38 mm) ID	193423		193423		1

* These parts are included in the Seal Repair Kit, which may be purchased separately. Refer to page 45.

† These parts are included in the Throat Packing Repair Kit, which may be purchased separately. Refer to page 45.

▲ Replacement Danger and Warning labels, tags and cards are available at no cost.

Displacement Pump Parts

SEVERE-DUTY ELECTROPOLISHED STAINLESS STEEL DISPLACEMENT PUMPS, WITH BSP THREADS

Model 240606, Series A, with tri-clamp adapters; for Pump Model 240625

Model 240607, Series A, without tri-clamp adapters; for Pump Model 240626

Model 240610, Series A, with tri-clamp adapters; for Pump Model 240618

Model 240611, Series A, without tri-clamp adapters; for Pump Model 240619

NOTE: See Service Section for important assembly procedures, torque notes, and sealants.

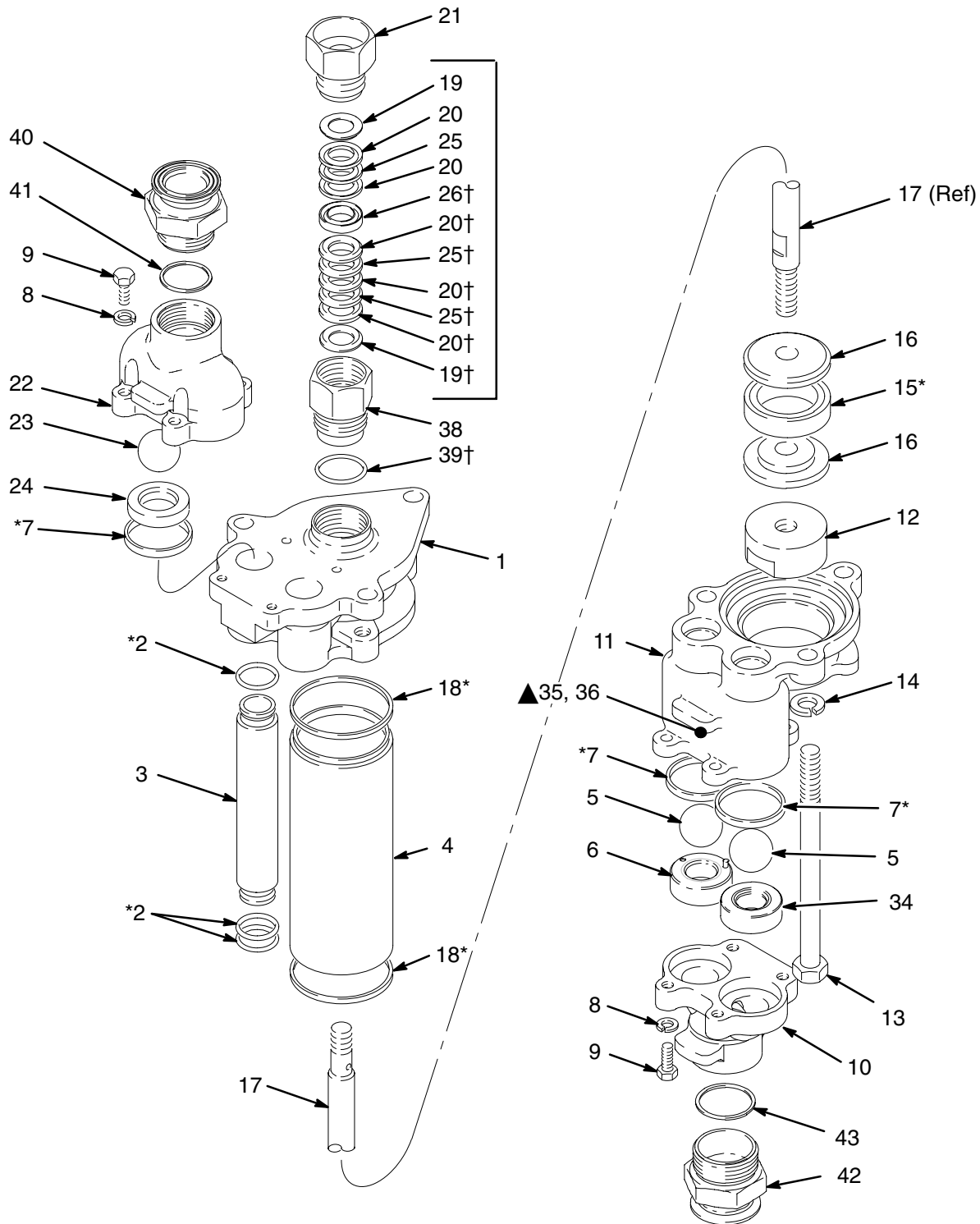

Displacement Pump Parts

SEVERE-DUTY ELECTROPOLISHED STAINLESS STEEL DISPLACEMENT PUMPS, WITH BSP THREADS

Models 240608 and 240612, Series A, with tri-clamp adapters; optional

Models 240609 and 240613, Series A, without tri-clamp adapters; optional

NOTE: Part numbers vary by pump. To find the part number used in your pump, read down the chart to find the desired ref. no., then read left to right to find the part number for your pump.

Ref. No.	Description	Displacement Pump Part Numbers				Qty
		240608	240609	240612	240613	
1	HOUSING, pump, upper; sst	192512	192512	192512	192512	1
2*	PACKING, o-ring; PTFE®	108526	108526	108526	108526	6
3	TUBE, fluid; sst	183085	183085	183085	183085	2
4	CYLINDER, pump; sst	183047	183047	183049	183049	1
5	BALL, intake; 1.25" diameter; sst	101968	101968	101968	101968	2
6	SEAT, intake valve, with relief valve; sst	239805	239805	239805	239805	1
7*	GASKET, seat, valve; UHMWPE	181877	181877	181877	181877	4
8	WASHER, flat; 8.4 mm; sst	111003	111003	111003	111003	8
9	CAPSCREW, hex hd; M8 x 1.25 x 25; sst	112084	112084	112084	112084	8
10	HOUSING, intake; sst	193205	193205	193205	193205	1
11	HOUSING, pump, lower; sst	181905	181905	181905	181905	1
12	NUT, piston; sst	108528	108528	108528	108528	1
13	CAPSCREW, hex hd; 9/16–12 unc x 7.75" long; sst	108523	108523	108523	108523	3
14	LOCKWASHER, spring; 9/16"; sst	108525	108525	108525	108525	3
15*	PACKING, piston; UHMWPE	183039	183039			1
	PACKING, piston; PTFE			187761	187761	1
16	PISTON; sst	183082	183082	183081	183081	2
17	ROD, piston; sst	181898	181898	181898	181898	1
18*	GASKET, cylinder; UHMWPE	183094	183094	181875	181875	2
19†	GLAND, male; sst	192263	192263	192263	192263	2
20†	V-PACKING, throat; UHMWPE	183295	183295			5
	V-PACKING, throat; PTFE			183352	183352	8
21	NUT, packing; sst	181684	181684	181684	181684	1
22	HOUSING, outlet; sst	193204	193204	193204	193204	1
23	BALL, outlet; 1" (25 mm) diameter; sst	110259	110259	110259	110259	2
24	SEAT, valve; sst	183095	183095	183095	183095	2
25†	V-PACKING, throat; leather	183294	183294			3
26†	GLAND, female; sst	192264	192264	192264	192264	1
34	SEAT, intake valve; sst	239865	239865	239865	239865	1
35▲	PLATE, warning	290537	290537	290537	290537	1
36	SCREW, drive, type U; 3/16" long	103972	103972	103972	103972	2
37▲	TAG, warning (not shown)	172479	172479	172479	172479	1
38	CARTRIDGE, throat; sst	192490	192490	192490	192490	1
39†	O-RING; PTFE	107313	107313	107313	107313	1
40	ADAPTER, tri-clamp; fluid outlet	193427		193427		1
41	SEAL; PTFE 1–1/4 in. (32 mm) ID	193422		193422		1
42	ADAPTER, tri-clamp; fluid inlet	193426		193426		1
43	SEAL; PTFE 1–1/2 in. (38 mm) ID	193423		193423		1

* These parts are included in the Seal Repair Kit, which may be purchased separately. Refer to page 45.

† These parts are included in the Throat Packing Repair Kit, which may be purchased separately. Refer to page 45.

▲ Replacement Danger and Warning labels, tags and cards are available at no cost.

Displacement Pump Parts

SEVERE-DUTY ELECTROPOLISHED STAINLESS STEEL DISPLACEMENT PUMPS, WITH BSP THREADS

Model 240608, Series A, with tri-clamp adapters; optional

Model 240609, Series A, without tri-clamp adapters; optional

Model 240612, Series A, with tri-clamp adapters; optional

Model 240613, Series A, without tri-clamp adapters; optional

NOTE: See Service Section for important assembly procedures, torque notes, and sealants.

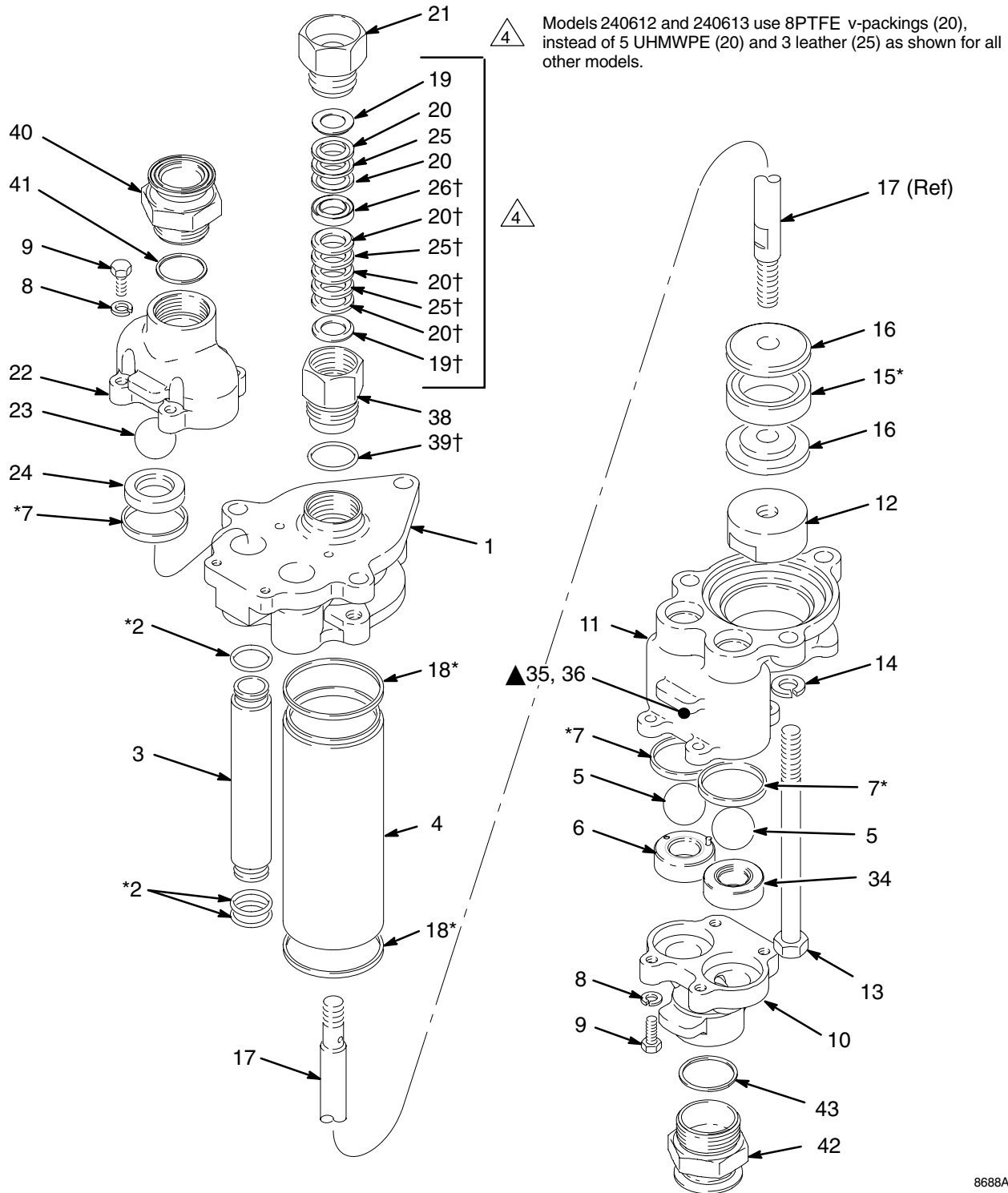

Seal and Throat Packing Kits

NOTE: To find the part number of a repair or conversion kit, read down the chart to find the desired kit description, then read left to right to find the kit number for your pump.

Description	Pump and Displacement Pump Part Numbers			
	220561 (cst) 220564 (sst) 236601 (cst) 236602 (sst) 239833 (cst) 239836 (sst) 239854 (sst) 239855 (cst) 240610 (sst) 240611 (sst) 240618 (sst) 240619 (sst)	220560 (cst) 220563 (sst) 220565 (cst) 220568 (sst) 236605 (cst) 236606 (sst) 239834 (cst) 239837 (sst)	220562 (sst) 220567 (cst) 220570 (sst) 220577 (cst) 220578 (sst) 236712 (cst) 236713 (sst) 239835 (cst) 239838 (sst) 240606 (sst) 240607 (sst) 240625 (sst) 240626 (sst)	237222 (sst) 237223 (cst) 239859 (sst) 239860 (cst)
UHMWPE Seal Kit (includes items 2, 7, 15, and 18)	220589	220588	220587	220589
PTFE Seal Kit (includes items 2, 7, 15, and 18)	224934	224935	224936	224934
High Temperature UHMWPE Seal Conversion Kit (includes items 2, 7, 15, and 18)	236057			236057
UHMWPE/Leather Throat Packing Kit (includes items 19, 26, 39, five UHMWPE v-packings, item 20, and three leather v-packings, item 25)	239872	239872	239872	239872
PTFE Throat Packing Kit (includes items 19, 26, 39, and eight PTFE v-packings, item 20)	239866	239866	239866	239866
Leather Throat Packing Kit (includes items 19, 26, 39, and eight leather v-packings, item 25)	239868	239868	239868	239868

Conversion Kits

Intake Seat Conversion Kit 239867

Converts Series A High-Flo pumps to the new relief valve intake seat design.

Throat Cartridge Conversion Kit 239869

Converts carbon steel High-Flo displacement pumps to the cartridge design used on stainless steel pumps.

Accessories

Packing Nut Wrench 110335

For tightening the packing nut.

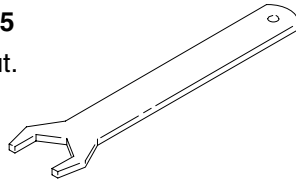

Pump Mounting Adapter Kits

Provides adapter plate and tie rods for retrofitting existing motor to a High-Flo displacement pump. Refer to Medium Volume High-Flo Accessories Manual 307837.

Graco-Approved Hydraulic Fluid

169236 20 liter (5 gal.)

207428 3.8 liter (1 gal.)

180090 0.9 m (3 ft) long

220579

For Series A, B, C, or D Bulldog Motors, Part No. 208356, and Series A Senator Motor, Part No. 217540. More recent series of these motors do not require this kit.

221159

Required for all Viscount I and President Motors.

Dimensions

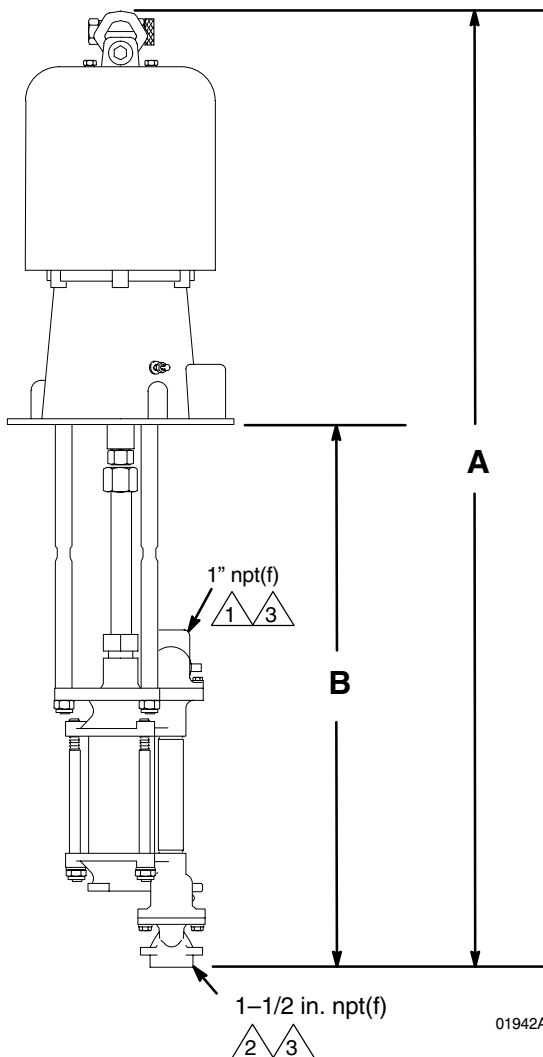

Pump Model	A	B	Weight (approx.)
President CST	1158 mm (45.60 in.)	731 mm (28.78 in.)	30 kg (66 lb)
President SST	1158 mm (45.60 in.)	731 mm (28.78 in.)	27 kg (59 lb)
President SST, with adjustable stroke	1222 mm (48.11 in.)	731 mm (28.78 in.)	27 kg (59 lb)
President CST stubby	1006 mm (39.60 in.)	579 mm (22.78 in.)	30 kg (66 lb)
President SST stubby	1006 mm (39.60 in.)	579 mm (22.78 in.)	27 kg (59 lb)
Senator CST	1260 mm (49.60 in.)	712 mm (28.04 in.)	36 kg (80 lb)
Senator SST	1260 mm (49.60 in.)	712 mm (28.04 in.)	33 kg (73 lb)
Bulldog CST	1258 mm (49.53 in.)	712 mm (28.04 in.)	42 kg (92 lb)
Bulldog SST	1258 mm (49.53 in.)	712 mm (28.04 in.)	39 kg (85 lb)
Viscount I+ CST	1245 mm (49.0 in.)	711 mm (28.0 in.)	35 kg (76 lb)
Viscount I+ SST	1245 mm (49.0 in.)	711 mm (28.0 in.)	32 kg (69 lb)

1 Models 240618, 240619, 240625, and 240626:
1-1/4" bsp(f)

2 Models 240618, 240619, 240625, and 240626:
1-1/2" bsp(f)

3 Models 240618 and 240625 include tri-clamp adapters

Pump Mounting Hole Diagram

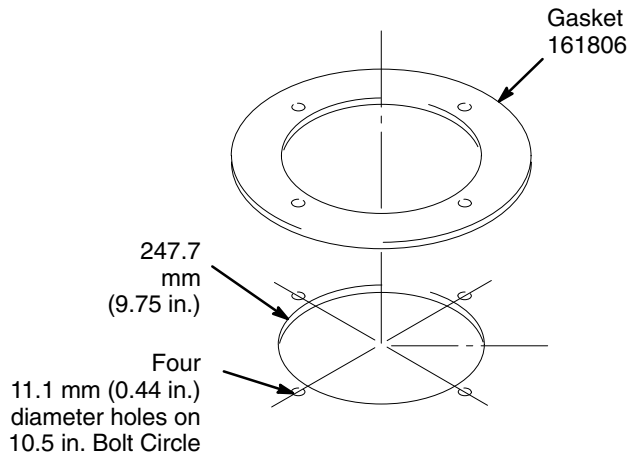

Bolt Pattern for 220581 Pump Stand

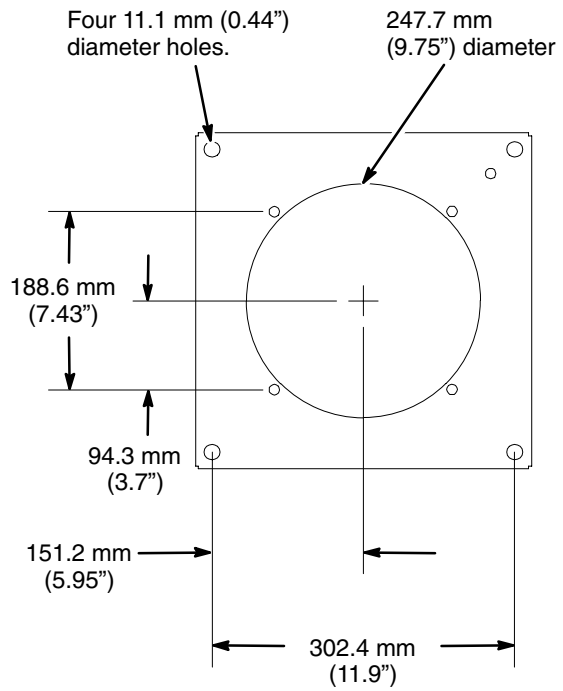

Bolt Pattern for 218742 Surge Tank Stand

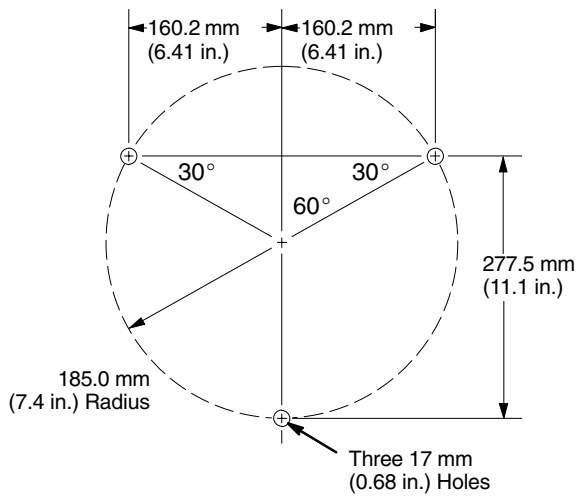

04598

01943

Technical Data

1.5:1 Ratio President Pump Model 220562

Category	Data
Maximum Working Pressure	1.9 MPa, 19 bar (270 psi)
Air Operating Range	0.1–1.2 MPa, 1.4–12 bar (20–180 psi)
Air Consumption	See Performance Chart
Fluid Flow at 60 cycles per minute	68.9 liter/min (18.2 gpm)
Pump Cycles Per Liter (gallon)	0.90 (3.3)
Maximum Fluid Temperature Rating	66°C (150°F)
Air Inlet	1/2 npt(f)
Fluid Inlet	1–1/2" npt(f)
Fluid Outlet	1" npt
Wetted Parts	Model 220562: Chrome-Plated Stainless Steel, Leather, PTFE®, Ultra-High Molecular Weight Polyethylene

PTFE®

Loctite® is a registered trademark of the Loctite Corp.

Sound Pressure Levels (measured at 1 meter from unit)

Air Motor	Input Air Pressures at 15 cycles per minute		
	40 psi (0.28 MPa, 2.8 bar)	70 psi (0.48 MPa, 4.8 bar)	100 psi (0.7 MPa, 7 bar)
President	73.6 dB(A)	78.3 dB(A)	80.9 dB(A)

Sound Power Levels (tested in accordance with ISO 9614–2)

Air Motor	Input Air Pressures at 15 cycles per minute		
	40 psi (0.28 MPa, 2.8 bar)	70 psi (0.48 MPa, 4.8 bar)	100 psi (0.7 MPa, 7 bar)
President	87.4 dB(A)	92.1 dB(A)	94.6 dB(A)

Performance Charts

To find Fluid Outlet Pressure (psi/MPa/bar) at a specific fluid flow (lpm/gpm) and operating air pressure (psi/MPa/bar):

1. Locate desired flow along bottom of chart.
2. Follow vertical line up to intersection with selected fluid outlet pressure curve (black). Follow left to scale to read fluid outlet pressure.

To find Pump Air Consumption (m³/min or scfm) at a specific fluid flow (lpm/gpm) and air pressure (psi/MPa/bar):

1. Locate desired flow along bottom of chart.
2. Read vertical line up to intersection with selected air consumption curve (dashes). Follow left to scale to read air consumption.

- A** 0.7 MPa, 7 bar (100 psi) air pressure
B 0.49 MPa, 4.9 bar (70 psi) air pressure
C 0.28 MPa, 2.8 bar (40 psi) air pressure

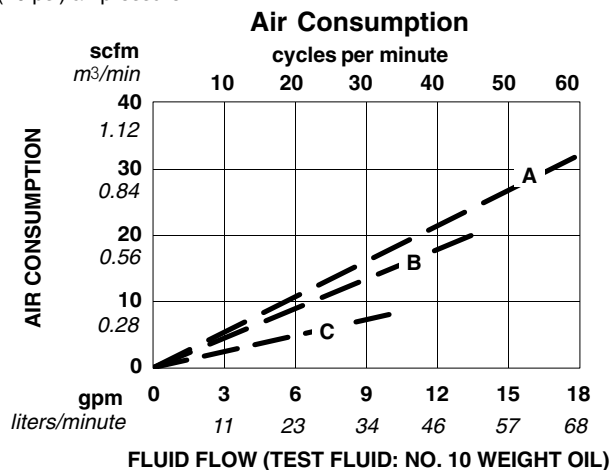
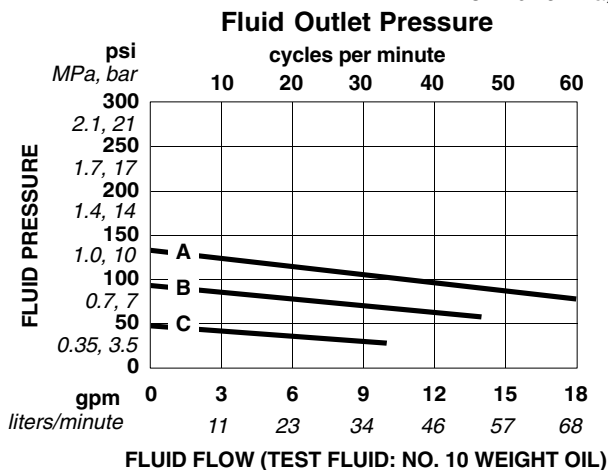

Technical Data

2:1 Ratio President Pumps, Models 220560 and 220563

Category	Data
Maximum Working Pressure	2.5 MPa, 25 bar (360 psi)
Air Operating Range	0.1–1.2 MPa, 1.4–12 bar (20–180 psi)
Air Consumption	See Performance Chart
Fluid Flow at 60 cycles per minute	49.2 liter/min (13.0 gpm)
Pump Cycles Per Liter (gallon)	1.2 (4.6)
Maximum Fluid Temperature Rating	66°C (150°F)
Air Inlet	1/2 npt(f)
Fluid Inlet	1–1/2" npt(f)
Fluid Outlet	1" npt
Wetted Parts	<i>Model 220560:</i> Carbon Steel, Stainless Steel, Leather, PTFE®, Ultra-High Molecular Weight Polyethylene <i>Model 220563:</i> Chrome-Plated Stainless Steel, Leather, PTFE®, Ultra-High Molecular Weight Polyethylene

PTFE®

Loctite® is a registered trademark of the Loctite Corp.

Sound Pressure Levels (measured at 1 meter from unit)

Air Motor	Input Air Pressures at 15 cycles per minute		
	40 psi (0.28 MPa, 2.8 bar)	70 psi (0.48 MPa, 4.8 bar)	100 psi (0.7 MPa, 7 bar)
President	73.6 dB(A)	78.3 dB(A)	80.9 dB(A)

Sound Power Levels (tested in accordance with ISO 9614–2)

Air Motor	Input Air Pressures at 15 cycles per minute		
	40 psi (0.28 MPa, 2.8 bar)	70 psi (0.48 MPa, 4.8 bar)	100 psi (0.7 MPa, 7 bar)
President	87.4 dB(A)	92.1 dB(A)	94.6 dB(A)

Performance Charts

To find Fluid Outlet Pressure (psi/MPa/bar) at a specific fluid flow (lpm/gpm) and operating air pressure (psi/MPa/bar):

1. Locate desired flow along bottom of chart.
2. Follow vertical line up to intersection with selected fluid outlet pressure curve (black). Follow left to scale to read fluid outlet pressure.

To find Pump Air Consumption (m³/min or scfm) at a specific fluid flow (lpm/gpm) and air pressure (psi/MPa/bar):

1. Locate desired flow along bottom of chart.
2. Read vertical line up to intersection with selected air consumption curve (dashes). Follow left to scale to read air consumption.

- A 0.7 MPa, 7 bar (100 psi) air pressure
 B 0.49 MPa, 4.9 bar (70 psi) air pressure
 C 0.28 MPa, 2.8 bar (40 psi) air pressure

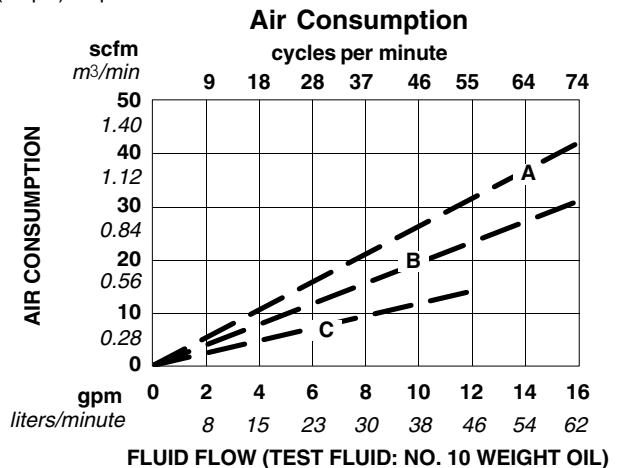
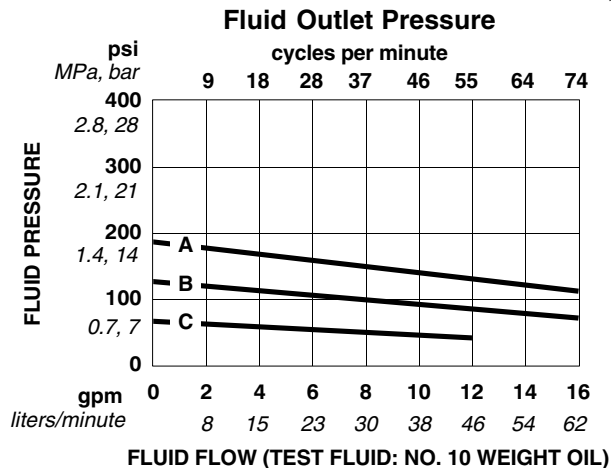

Technical Data

3:1 Ratio President Pumps, Models 220561, 220564, 237222, 237223, 239855, 239854, 240618, and 240619

Category	Data
Maximum Working Pressure	3.4 MPa, 34 bar (500 psi)
Air Operating Range	0.1–1.1 MPa, 1.4–11 bar (20–166 psi)
Air Consumption	See Performance Chart
Fluid Flow at 60 cycles per minute	37.1 liter/min (9.8 gpm)
Pump Cycles Per Liter (gallon)	1.6 (6.12)
Maximum Fluid Temperature Rating	66°C (150°F)
Air Inlet	1/2 npt(f)
Fluid Inlet	<i>Model 220561, 220564, 237222, 237223, 239854, and 239855: 1–1/2" npt(f)</i> <i>Model 240618 and 240619: 1–1/2" bsp(f)</i>
Fluid Outlet	<i>Model 220561, 220564, 237222, 237223, 239854, and 239855: 1" npt(f)</i> <i>Model 240618 and 240619: 1–1/4" bsp(f)</i>
Wetted Parts	<i>Model 220561 and 239855: Carbon Steel, Stainless Steel, Leather, PTFE®, Ultra-High Molecular Weight Polyethylene</i> <i>Model 220564, 239854, 240618, and 240619 : Chrome-Plated Stainless Steel, Leather, PTFE®, Ultra-High Molecular Weight Polyethylene</i> <i>Model 237223: Carbon Steel, Stainless Steel, PTFE®, Ultra-High Molecular Weight Polyethylene</i> <i>Model 237222: Chrome-Plated Stainless Steel, PTFE®, Ultra-High Molecular Weight Polyethylene</i>

PTFE®

Loctite® is a registered trademark of the Loctite Corp.

Sound Pressure Levels (measured at 1 meter from unit)

Air Motor	Input Air Pressures at 15 cycles per minute		
	40 psi (0.28 MPa, 2.8 bar)	70 psi (0.48 MPa, 4.8 bar)	100 psi (0.7 MPa, 7 bar)
President	73.6 dB(A)	78.3 dB(A)	80.9 dB(A)

Sound Power Levels (tested in accordance with ISO 9614–2)

Air Motor	Input Air Pressures at 15 cycles per minute		
	40 psi (0.28 MPa, 2.8 bar)	70 psi (0.48 MPa, 4.8 bar)	100 psi (0.7 MPa, 7 bar)
President	87.4 dB(A)	92.1 dB(A)	94.6 dB(A)

Technical Data

3:1 Ratio President Pumps, Models 220561, 220564, 237222, 237223, 239855, 239854, 240618, and 240619

Performance Charts

To find Fluid Outlet Pressure (psi/MPa/bar) at a specific fluid flow (lpm/gpm) and operating air pressure (psi/MPa/bar):

1. Locate desired flow along bottom of chart.
2. Follow vertical line up to intersection with selected fluid outlet pressure curve (black). Follow left to scale to read fluid outlet pressure.

To find Pump Air Consumption (m³/min or scfm) at a specific fluid flow (lpm/gpm) and air pressure (psi/MPa/bar):

1. Locate desired flow along bottom of chart.
2. Read vertical line up to intersection with selected air consumption curve (dashes). Follow left to scale to read air consumption.

- A 0.7 MPa, 7 bar (100 psi) air pressure
 B 0.49 MPa, 4.9 bar (70 psi) air pressure
 C 0.28 MPa, 2.8 bar (40 psi) air pressure

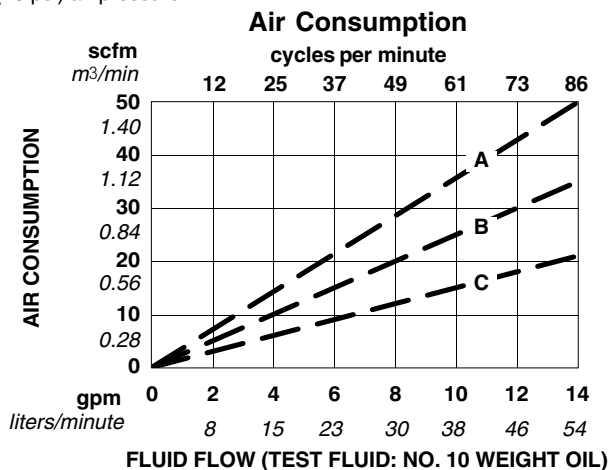
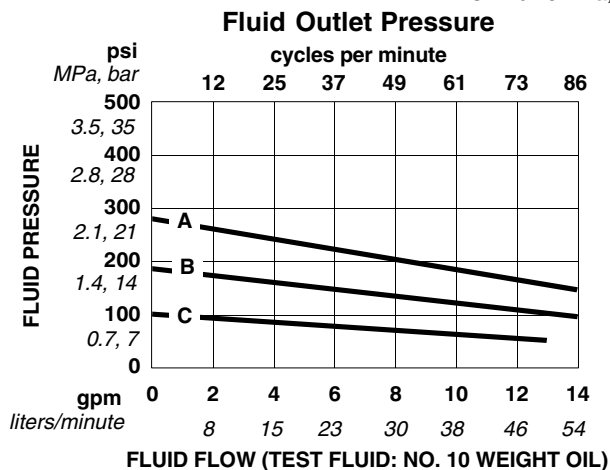

Technical Data

2.5:1 Ratio Quiet Senator Pumps, Models 220567 and 220570

Category	Data
Maximum Working Pressure	1.7 MPa, 17 bar (250 psi)
Air Operating Range	0.28–0.7 MPa, 2.8–7 bar (40–100 psi)
Air Consumption	See Performance Chart
Fluid Flow at 60 cycles per minute	89.9 liter/min (24 gpm)
Pump Cycles Per Liter (gallon)	0.66 (2.5)
Maximum Fluid Temperature Rating	66°C (150°F)
Air Inlet	3/4 npsm(f)
Fluid Inlet	1–1/2" npt(f)
Fluid Outlet	1" npt
Wetted Parts	<i>Model 220567:</i> Carbon Steel, Stainless Steel, Leather, PTFE®, Ultra-High Molecular Weight Polyethylene <i>Model 220570:</i> Chrome-Plated Stainless Steel, Leather, PTFE®, Ultra-High Molecular Weight Polyethylene

PTFE®

Loctite® is a registered trademark of the Loctite Corp.

Sound Pressure Levels (measured at 1 meter from unit)

Air Motor	Input Air Pressures at 15 cycles per minute		
	40 psi (0.28 MPa, 2.8 bar)	70 psi (0.48 MPa, 4.8 bar)	100 psi (0.7 MPa, 7 bar)
Quiet Senator	83.4 dB(A)	84.3 dB(A)	88.5 dB(A)

Sound Power Levels (tested in accordance with ISO 9614–2)

Air Motor	Input Air Pressures at 15 cycles per minute		
	40 psi (0.28 MPa, 2.8 bar)	70 psi (0.48 MPa, 4.8 bar)	100 psi (0.7 MPa, 7 bar)
Quiet Senator	89.8 dB(A)	91.8 dB(A)	94.4 dB(A)

Performance Charts

To find Fluid Outlet Pressure (psi/MPa/bar) at a specific fluid flow (lpm/gpm) and operating air pressure (psi/MPa/bar):

1. Locate desired flow along bottom of chart.
2. Follow vertical line up to intersection with selected fluid outlet pressure curve (black). Follow left to scale to read fluid outlet pressure.

To find Pump Air Consumption (m³/min or scfm) at a specific fluid flow (lpm/gpm) and air pressure (psi/MPa/bar):

1. Locate desired flow along bottom of chart.
2. Read vertical line up to intersection with selected air consumption curve (dashes). Follow left to scale to read air consumption.

- A** 0.7 MPa, 7 bar (100 psi) air pressure
B 0.49 MPa, 4.9 bar (70 psi) air pressure
C 0.28 MPa, 2.8 bar (40 psi) air pressure

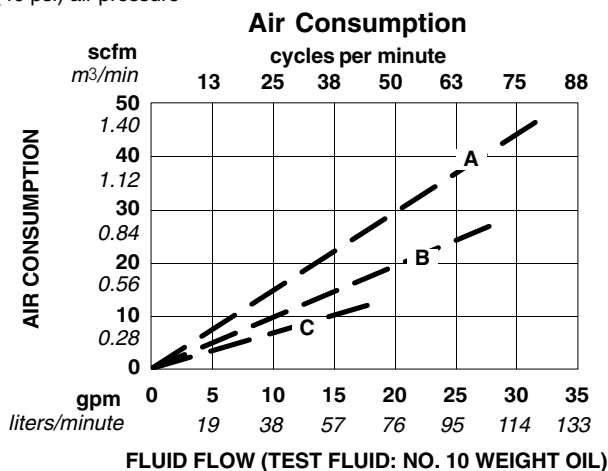
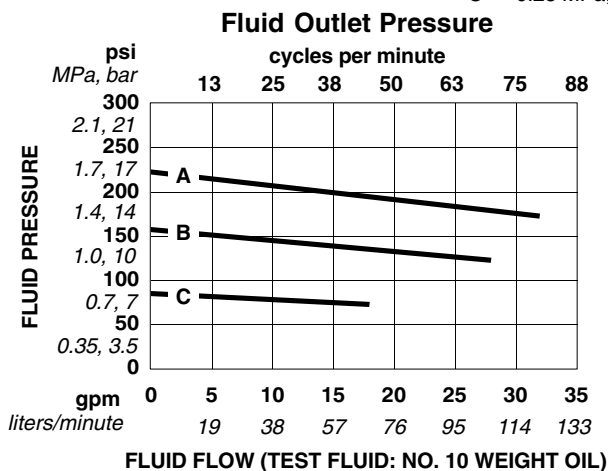

Technical Data

3.5:1 Ratio Quiet Senator Pumps, Models 220565 and 220568

Category	Data
Maximum Working Pressure	2.4 MPa, 24 bar (350 psi)
Air Operating Range	0.28–0.7 MPa, 2.8–7 bar (40–100 psi)
Air Consumption	See Performance Chart
Fluid Flow at 60 cycles per minute	65.8 liter/min (17.4 gpm)
Pump Cycles Per Liter (gallon)	0.91 (3.44)
Maximum Fluid Temperature Rating	66°C (150°F)
Air Inlet	3/4 npsm(f)
Fluid Inlet	1–1/2" npt(f)
Fluid Outlet	1" npt
Wetted Parts	<i>Model 220565:</i> Carbon Steel, Stainless Steel, Leather, PTFE®, Ultra-High Molecular Weight Polyethylene <i>Model 220568:</i> Chrome-Plated Stainless Steel, Leather, PTFE®, Ultra-High Molecular Weight Polyethylene

PTFE®

Loctite® is a registered trademark of the Loctite Corp.

Sound Pressure Levels (measured at 1 meter from unit)

Air Motor	Input Air Pressures at 15 cycles per minute		
	40 psi (0.28 MPa, 2.8 bar)	70 psi (0.48 MPa, 4.8 bar)	100 psi (0.7 MPa, 7 bar)
Quiet Senator	83.4 dB(A)	84.3 dB(A)	88.5 dB(A)

Sound Power Levels (tested in accordance with ISO 9614–2)

Air Motor	Input Air Pressures at 15 cycles per minute		
	40 psi (0.28 MPa, 2.8 bar)	70 psi (0.48 MPa, 4.8 bar)	100 psi (0.7 MPa, 7 bar)
Quiet Senator	89.8 dB(A)	91.8 dB(A)	94.4 dB(A)

Performance Charts

To find Fluid Outlet Pressure (psi/MPa/bar) at a specific fluid flow (lpm/gpm) and operating air pressure (psi/MPa/bar):

1. Locate desired flow along bottom of chart.
2. Follow vertical line up to intersection with selected fluid outlet pressure curve (black). Follow left to scale to read fluid outlet pressure.

To find Pump Air Consumption (m³/min or scfm) at a specific fluid flow (lpm/gpm) and air pressure (psi/MPa/bar):

1. Locate desired flow along bottom of chart.
2. Read vertical line up to intersection with selected air consumption curve (dashes). Follow left to scale to read air consumption.

- A 0.7 MPa, 7 bar (100 psi) air pressure
 B 0.49 MPa, 4.9 bar (70 psi) air pressure
 C 0.28 MPa, 2.8 bar (40 psi) air pressure

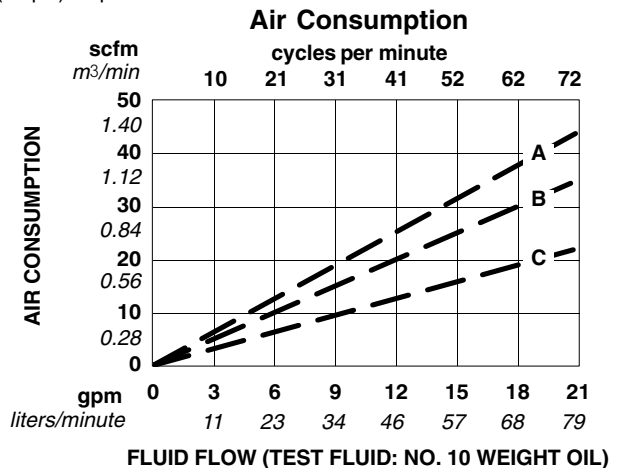
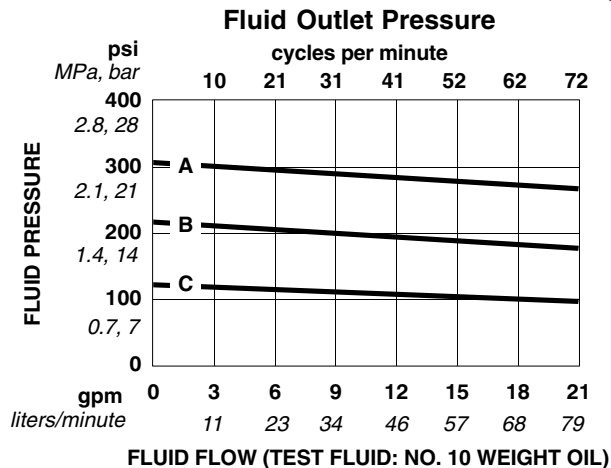

Technical Data

4:1 Ratio Quiet Bulldog Pumps, Models 220577, 220578, 240625, and 240626

Category	Data
Maximum Working Pressure	2.8 MPa, 28 bar (400 psi)
Air Operating Range	0.28–0.7 MPa, 2.8–7 bar (40–100 psi)
Air Consumption	See Performance Chart
Fluid Flow at 60 cycles per minute	90.8 liter/min (24 gpm)
Pump Cycles Per Liter (gallon)	0.66 (2.5)
Maximum Fluid Temperature Rating	66°C (150°F)
Air Inlet	3/4 npsm(f)
Fluid Inlet	Model 220577 and 220578: 1–1/2" npt(f) Model 240625 and 240626: 1–1/2" bsp(f)
Fluid Outlet	Model 220577 and 220578: 1" npt(f) Model 240625 and 240626: 1–1/4" bsp(f)
Wetted Parts	Model 220577: Carbon Steel, Stainless Steel, Leather, PTFE®, Ultra-High Molecular Weight Polyethylene Models 220578, 240625, and 240626: Chrome-Plated Stainless Steel, Leather, PTFE®, Ultra-High Molecular Weight Polyethylene

PTFE®

Loctite® is a registered trademark of the Loctite Corp.

Sound Pressure Levels (measured at 1 meter from unit)

Air Motor	Input Air Pressures at 15 cycles per minute		
	40 psi (0.28 MPa, 2.8 bar)	70 psi (0.48 MPa, 4.8 bar)	90 psi (0.6 MPa, 6.2 bar)
Quiet Bulldog	81.5 dB(A)	83.6 dB(A)	85.6 dB(A)

Sound Power Levels (tested in accordance with ISO 9614–2)

Air Motor	Input Air Pressures at 15 cycles per minute		
	40 psi (0.28 MPa, 2.8 bar)	70 psi (0.48 MPa, 4.8 bar)	90 psi (0.6 MPa, 6.2 bar)
Quiet Bulldog	90.2 dB(A)	93.5 dB(A)	94.9 dB(A)

Performance Charts

To find Fluid Outlet Pressure (psi/MPa/bar) at a specific fluid flow (lpm/gpm) and operating air pressure (psi/MPa/bar):

1. Locate desired flow along bottom of chart.
2. Follow vertical line up to intersection with selected fluid outlet pressure curve (black). Follow left to scale to read fluid outlet pressure.

To find Pump Air Consumption (m³/min or scfm) at a specific fluid flow (lpm/gpm) and air pressure (psi/MPa/bar):

1. Locate desired flow along bottom of chart.
2. Read vertical line up to intersection with selected air consumption curve (dashes). Follow left to scale to read air consumption.

- A 0.7 MPa, 7 bar (100 psi) air pressure
 B 0.49 MPa, 4.9 bar (70 psi) air pressure
 C 0.28 MPa, 2.8 bar (40 psi) air pressure

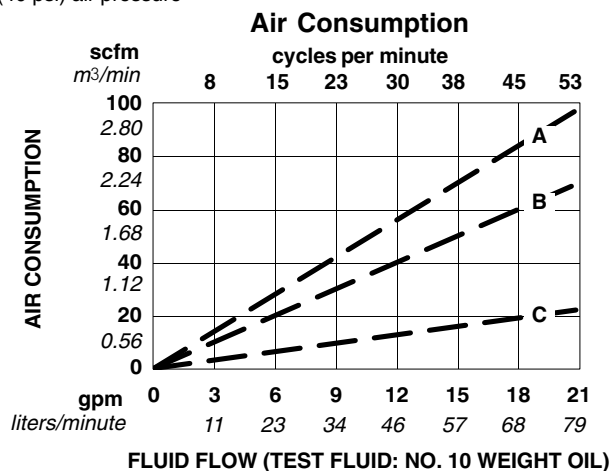
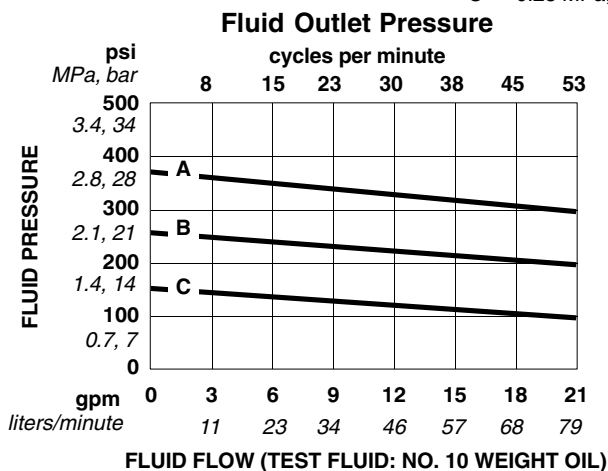

Technical Data

Viscount I+ Pumps, Models 236601 and 236602, 244142

Category	Data
Maximum Working Pressure	3.1 MPa, 31 bar (450 psi)
Maximum Hydraulic Working Pressure	10.3 MPa, 103 bar (1500 psi)
Hydraulic Oil Consumption	See Performance Chart
Maximum Hydraulic Motor Fluid Temperature	54°C (134°F)
Fluid Flow at 60 cycles per minute	36.5 liter/min (9.6 gpm)
Pump Cycles Per Liter (gallon)	1.64 (6.2)
Maximum Fluid Temperature Rating	66°C (150°F)
Hydraulic Fluid Inlet	3/4", (37° flare)
Hydraulic Fluid Outlet	7/8", (37° flare)
Fluid Inlet	1-1/2" npt(f)
Fluid Outlet	1" npt
Wetted Parts	<i>Model 236601:</i> Carbon Steel, Stainless Steel, Leather, PTFE®, Ultra-High Molecular Weight Polyethylene <i>Model 236602:</i> Chrome-Plated Stainless Steel, Leather, PTFE®, Ultra-High Molecular Weight Polyethylene

PTFE®

Loctite® is a registered trademark of the Loctite Corp.

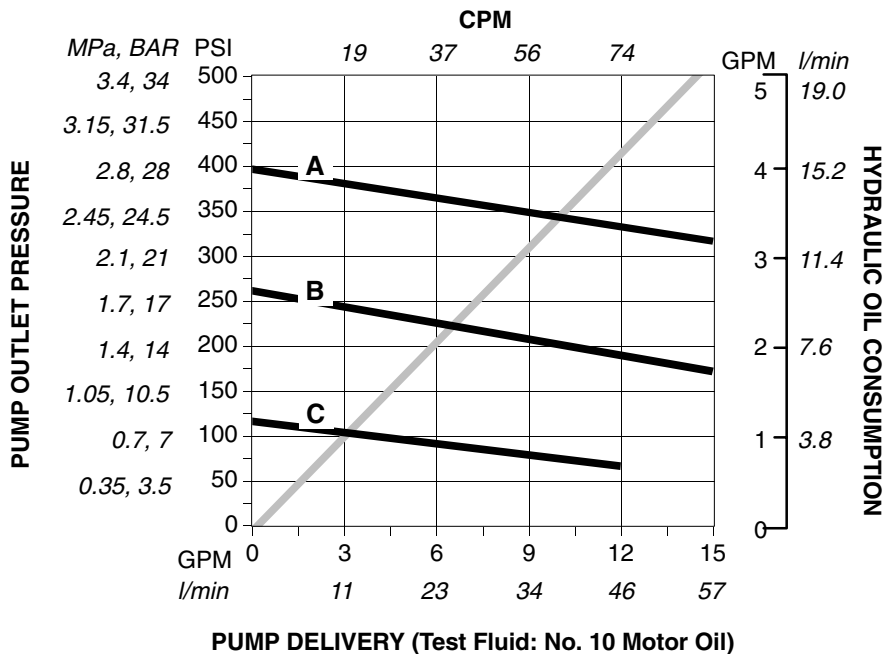

- A** 10.3 MPa, 103 bar (1500 psi) hydraulic oil pressure
- B** 7.0 MPa, 70 bar (1000 psi) hydraulic oil pressure
- C** 3.4 MPa, 34 bar (500 psi) hydraulic oil pressure

To find Outlet Pressure (MPa/bar/psi) at a specific delivery (liter/min or gpm) and operating hydraulic pressure (MPa/bar/psi):

1. Locate desired delivery along bottom of chart.
2. Read vertical line up to intersection with selected fluid outlet pressure curve (black curves). Curve slopes down from left to right. Follow left to scale and read outlet pressure.

To find Motor Hydraulic Oil Consumption (liter/min or gpm) at a specific delivery (liter/min or gpm) :

1. Locate desired delivery along bottom of chart.
2. Read vertical line up to intersection with hydraulic oil consumption curve (gray curve). Curve slopes up from left to right. Follow right to scale and read hydraulic oil consumption.

Technical Data

Viscount I+ Pumps, Models 236605 and 236606

Category	Data
Maximum Working Pressure	2.1 MPa, 21 bar (300 psi)
Maximum Hydraulic Working Pressure	10.3 MPa, 103 bar (1500 psi)
Hydraulic Oil Consumption	See Performance Chart
Maximum Hydraulic Motor Fluid Temperature	54°C (134°F)
Fluid Flow at 60 cycles per minute	55.6 liter/min (14.7 gpm)
Pump Cycles Per Liter (gallon)	1.1 (4.1)
Maximum Fluid Temperature Rating	66°C (150°F)
Hydraulic Fluid Inlet	3/4", (37° flare)
Hydraulic Fluid Outlet	7/8", (37° flare)
Fluid Inlet	1-1/2" npt(f)
Fluid Outlet	1" npt
Wetted Parts	<i>Model 236605:</i> Carbon Steel, Stainless Steel, Leather, PTFE®, Ultra-High Molecular Weight Polyethylene <i>Model 236606:</i> Chrome-Plated Stainless Steel, Leather, PTFE®, Ultra-High Molecular Weight Polyethylene

PTFE®

Loctite® is a registered trademark of the Loctite Corp.

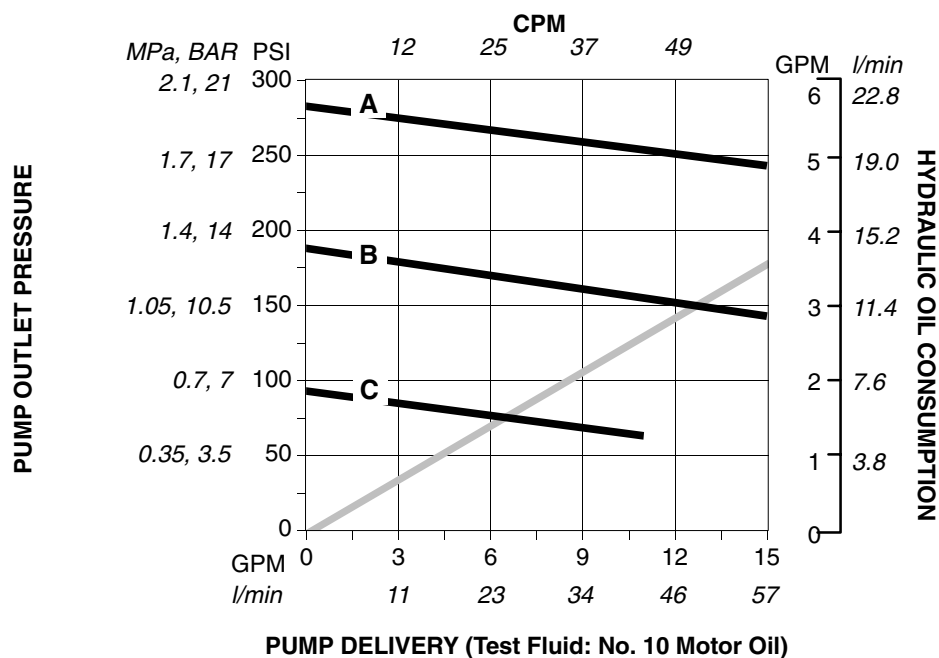

- A** 10.3 MPa, 103 bar (1500 psi) hydraulic oil pressure
- B** 7.0 MPa, 70 bar (1000 psi) hydraulic oil pressure
- C** 3.4 MPa, 34 bar (500 psi) hydraulic oil pressure

To find Outlet Pressure (MPa/bar/psi) at a specific delivery (liter/min or gpm) and operating hydraulic pressure (MPa/bar/psi):

1. Locate desired delivery along bottom of chart.
2. Read vertical line up to intersection with selected fluid outlet pressure curve (black curves). Curve slopes down from left to right. Follow left to scale and read outlet pressure.

To find Motor Hydraulic Oil Consumption (liter/min or gpm) at a specific delivery (liter/min or gpm) :

1. Locate desired delivery along bottom of chart.
2. Read vertical line up to intersection with hydraulic oil consumption curve (gray curve). Curve slopes up from left to right. Follow right to scale and read hydraulic oil consumption.

Technical Data

Viscount I+ Pumps, Models 236712 and 236713

Category	Data
Maximum Working Pressure	1.5 MPa, 15 bar (225 psi)
Maximum Hydraulic Working Pressure	10.3 MPa, 103 bar (1500 psi)
Hydraulic Oil Consumption	See Performance Chart
Maximum Hydraulic Motor Fluid Temperature	54°C (134°F)
Fluid Flow at 60 cycles per minute	75.6 liter/min (20 gpm)
Pump Cycles Per Liter (gallon)	0.8 (3.0)
Maximum Fluid Temperature Rating	66°C (150°F)
Hydraulic Fluid Inlet	3/4", (37° flare)
Hydraulic Fluid Outlet	7/8", (37° flare)
Fluid Inlet	1-1/2" npt(f)
Fluid Outlet	1" npt
Wetted Parts	<i>Model 236712:</i> Carbon Steel, Stainless Steel, Leather, PTFE®, Ultra-High Molecular Weight Polyethylene <i>Model 236713:</i> Chrome-Plated Stainless Steel, Leather, PTFE®, Ultra-High Molecular Weight Polyethylene

PTFE®

Loctite® is a registered trademark of the Loctite Corp.

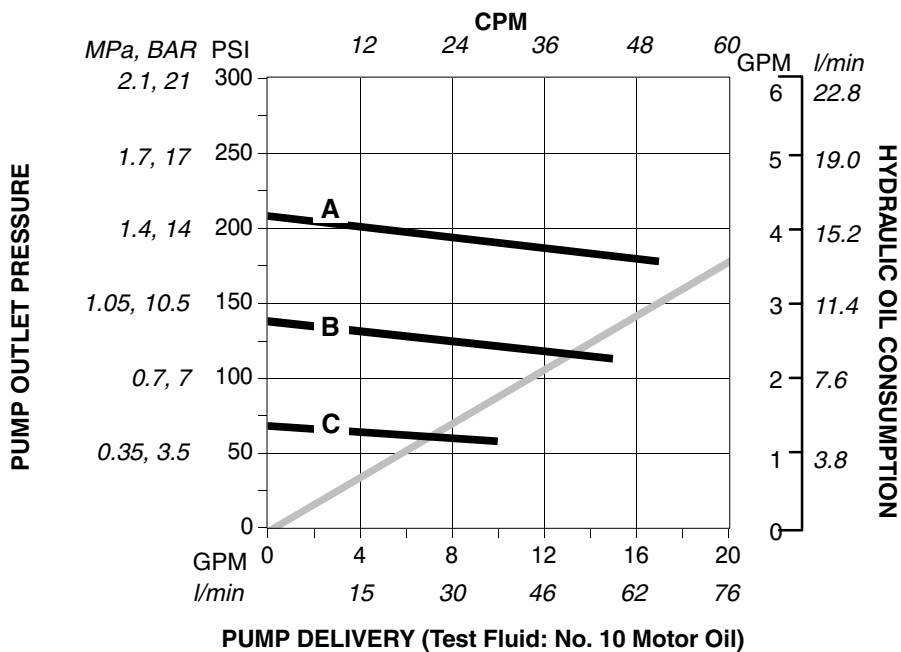

- A** 10.3 MPa, 103 bar (1500 psi) hydraulic oil pressure
- B** 7.0 MPa, 70 bar (1000 psi) hydraulic oil pressure
- C** 3.4 MPa, 34 bar (500 psi) hydraulic oil pressure

To find Outlet Pressure (MPa/bar/psi) at a specific delivery (liter/min or gpm) and operating hydraulic pressure (MPa/bar/psi):

1. Locate desired delivery along bottom of chart.
2. Read vertical line up to intersection with selected fluid outlet pressure curve (black curves). Curve slopes down from left to right. Follow left to scale and read outlet pressure.

To find Motor Hydraulic Oil Consumption (liter/min or gpm) at a specific delivery (liter/min or gpm) :

1. Locate desired delivery along bottom of chart.
2. Read vertical line up to intersection with hydraulic oil consumption curve (gray curve). Curve slopes up from left to right. Follow right to scale and read hydraulic oil consumption.

Graco Standard Warranty

Graco warrants all equipment manufactured by Graco and bearing its name to be free from defects in material and workmanship on the date of sale by an authorized Graco distributor to the original purchaser for use. With the exception of any special, extended, or limited warranty published by Graco, Graco will, for a period of twelve months from the date of sale, repair or replace any part of the equipment determined by Graco to be defective. This warranty applies only when the equipment is installed, operated and maintained in accordance with Graco's written recommendations.

This warranty does not cover, and Graco shall not be liable for general wear and tear, or any malfunction, damage or wear caused by faulty installation, misapplication, abrasion, corrosion, inadequate or improper maintenance, negligence, accident, tampering, or substitution of non-Graco component parts. Nor shall Graco be liable for malfunction, damage or wear caused by the incompatibility of Graco equipment with structures, accessories, equipment or materials not supplied by Graco, or the improper design, manufacture, installation, operation or maintenance of structures, accessories, equipment or materials not supplied by Graco.

This warranty is conditioned upon the prepaid return of the equipment claimed to be defective to an authorized Graco distributor for verification of the claimed defect. If the claimed defect is verified, Graco will repair or replace free of charge any defective parts. The equipment will be returned to the original purchaser transportation prepaid. If inspection of the equipment does not disclose any defect in material or workmanship, repairs will be made at a reasonable charge, which charges may include the costs of parts, labor, and transportation.

THIS WARRANTY IS EXCLUSIVE, AND IS IN LIEU OF ANY OTHER WARRANTIES, EXPRESS OR IMPLIED, INCLUDING BUT NOT LIMITED TO WARRANTY OF MERCHANTABILITY OR WARRANTY OF FITNESS FOR A PARTICULAR PURPOSE.

Graco's sole obligation and buyer's sole remedy for any breach of warranty shall be as set forth above. The buyer agrees that no other remedy (including, but not limited to, incidental or consequential damages for lost profits, lost sales, injury to person or property, or any other incidental or consequential loss) shall be available. Any action for breach of warranty must be brought within two (2) years of the date of sale.

Graco makes no warranty, and disclaims all implied warranties of merchantability and fitness for a particular purpose in connection with accessories, equipment, materials or components sold but not manufactured by Graco. These items sold, but not manufactured by Graco (such as electric motors, switches, hose, etc.), are subject to the warranty, if any, of their manufacturer. Graco will provide purchaser with reasonable assistance in making any claim for breach of these warranties.

In no event will Graco be liable for indirect, incidental, special or consequential damages resulting from Graco supplying equipment hereunder, or the furnishing, performance, or use of any products or other goods sold hereto, whether due to a breach of contract, breach of warranty, the negligence of Graco, or otherwise.

FOR GRACO CANADA CUSTOMERS

The parties acknowledge that they have required that the present document, as well as all documents, notices and legal proceedings entered into, given or instituted pursuant hereto or relating directly or indirectly hereto, be drawn up in English. Les parties reconnaissent avoir convenu que la rédaction du présente document sera en Anglais, ainsi que tous documents, avis et procédures judiciaires exécutés, donnés ou intentés à la suite de ou en rapport, directement ou indirectement, avec les procédures concernées.

Graco Information

TO PLACE AN ORDER, contact your Graco distributor, or call one of the following numbers to identify the distributor closest to you:

1-800-367-4023 Toll Free

612-623-6921

612-378-3505 Fax

All written and visual data contained in this document reflects the latest product information available at the time of publication. Graco reserves the right to make changes at any time without notice.

Sales Offices: Minneapolis, Detroit
International Offices: Belgium, Korea, Hong Kong, Japan

www.graco.com

PRINTED IN USA 308793 09/1997, Revised 07/2003

Free Manuals Download Website

<http://myh66.com>

<http://usermanuals.us>

<http://www.somanuals.com>

<http://www.4manuals.cc>

<http://www.manual-lib.com>

<http://www.404manual.com>

<http://www.luxmanual.com>

<http://aubethermostatmanual.com>

Golf course search by state

<http://golfingnear.com>

Email search by domain

<http://emailbydomain.com>

Auto manuals search

<http://auto.somanuals.com>

TV manuals search

<http://tv.somanuals.com>