

User Manual

HandyTone-488

Analog Telephone Adaptor

For SW Release Version 1.0.0.4



Grandstream Networks, Inc.

www.grandstream.com



Table of Contents

1	WELCOME.....	3
2	INSTALLATION.....	4
3	WHAT IS INCLUDED IN THE PACKAGE	6
3.1	SAFETY COMPLIANCES	6
4	PRODUCT OVERVIEW.....	7
4.1	KEY FEATURES.....	7
4.2	HARDWARE SPECIFICATION	8
5	BASIC OPERATIONS.....	9
5.1	GET FAMILIAR WITH VOICE PROMPT	9
5.2	MAKE PHONE CALLS	10
5.2.1	<i>Calling phone or extension numbers</i>	<i>10</i>
5.2.2	<i>Direct IP calls.....</i>	<i>10</i>
5.2.3	<i>Blind Transfer</i>	<i>11</i>
5.2.4	<i>Attended Transfer.....</i>	<i>11</i>
5.2.5	<i>Send and Receive PSTN Calls.....</i>	<i>12</i>
5.2.6	<i>VoIP-to-PSTN Calls.....</i>	<i>12</i>
5.2.7	<i>PSTN-to-VoIP Calls.....</i>	<i>12</i>
5.3	CALL FEATURES.....	12
5.3.1	<i>Call Features Table</i>	<i>12</i>
5.3.2	<i>PSTN Pass Through.....</i>	<i>13</i>
5.4	LED LIGHT PATTERN INDICATION	13
6	CONFIGURATION GUIDE.....	15
6.1	CONFIGURING HANDYTONE-488 WAN IP THROUGH VOICE PROMPT	15
6.1.1	<i>DHCP Mode</i>	<i>15</i>
6.1.2	<i>STATIC IP Mode.....</i>	<i>15</i>
6.2	CONFIGURING HANDYTONE-488 WITH WEB BROWSER	15
6.2.1	<i>Access the Web Configuration Menu.....</i>	<i>15</i>
6.2.2	<i>End User Configuration</i>	<i>15</i>
6.2.3	<i>Advanced User Configuration.....</i>	<i>19</i>
6.2.4	<i>Saving the Configuration Changes</i>	<i>28</i>
6.2.5	<i>Rebooting the HandyTone-488 From Remote.....</i>	<i>28</i>
6.3	CONFIGURATION THROUGH A CENTRAL SERVER	29
7	SOFTWARE UPGRADE	30
7.1	UPGRADE THROUGH HTTP.....	30
7.2	UPGRADE THROUGH TFTP	30
8	RESTORE FACTORY DEFAULT SETTING.....	32

1 Welcome

Congratulations on becoming an owner of HandyTone-488. You made an excellent choice and we hope you enjoy all of its capabilities.

Grandstream's HandyTone-488 is an all-in-one VoIP integrated access device that features superb audio quality, rich functionalities, high level of integration, compactness and ultra-affordability. The HandyTone-488 is fully compatible with SIP industry standard and can interoperate with many other SIP compliant devices and software on the market.

Grandstream HandyTone-488 is a new addition to the popular HandyTone product family. It is an enhanced model compared to the award-winning HandyTone-486 in that it allows call origination and termination from/to the PSTN network (via FXO port) remotely and automated emergency call routing through PSTN network.

2 Installation

HandyTone-488 Analog Telephone Adaptor is an all-in-one VoIP integrated device designed to be a total solution for networks providing VoIP services.

The HandyTone-488 VoIP functionalities are available via a regular analog telephone.

The following photo illustrates the appearance of a HandyTone-488.

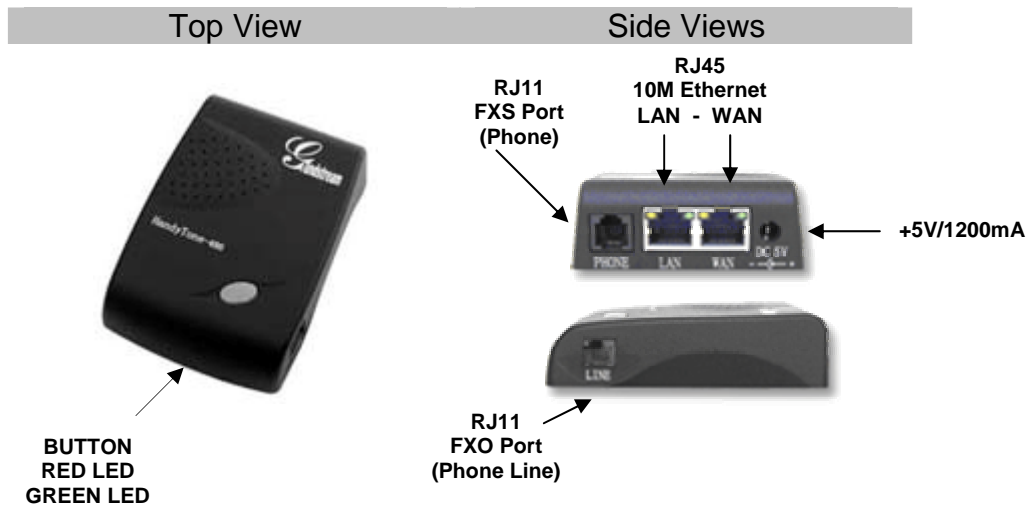

Interconnection Diagram of the HandyTone-488:

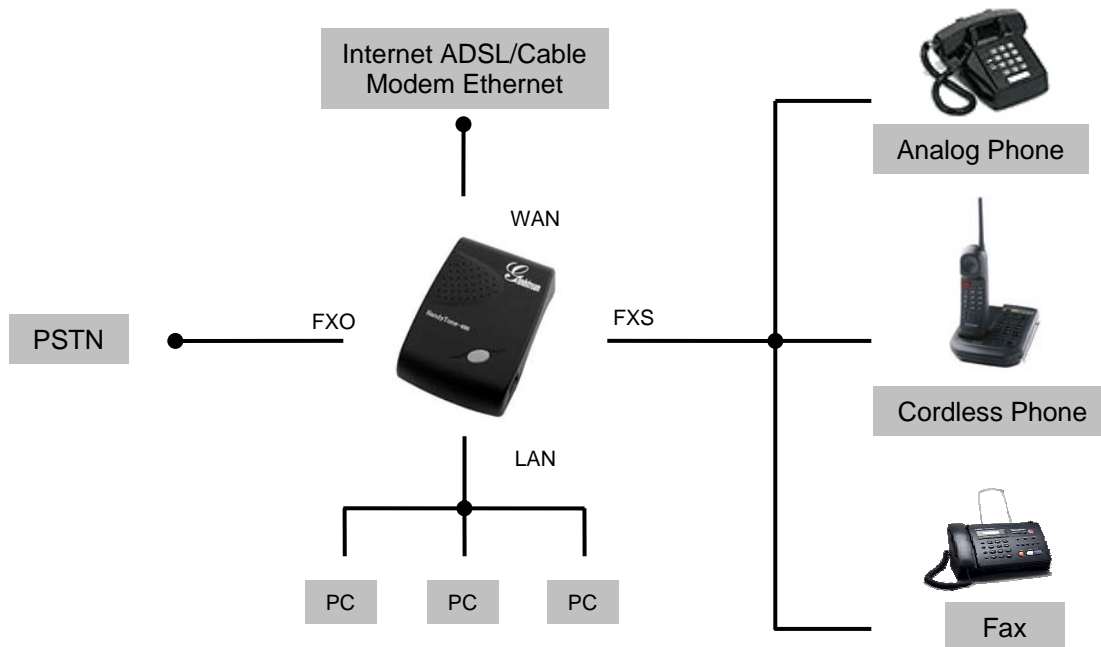

HandyTone-488 has one FXS port and one FXO port. The RJ11 jack next to the LAN port is a FXS port. The RJ11 jack on the side of the HandyTone-488 is a FXO port. Both the FXS port and the FXO port can have a separate SIP account. This is a key feature of HandyTone-488. Telephone calls can be originated or terminated from/to the PSTN network via FXO port.

Following are the steps to install a HandyTone-488:

1. Connect a standard touch-tone analog telephone to the FXS port.
2. Insert a standard RJ11 telephone cable into the FXO port and connect the other end of the telephone cable to a wall jack.
3. Insert the Ethernet cable into the WAN port of HandyTone-488 and connect the other end of the Ethernet cable to an uplink port (a router or a modem, etc.)
4. Connect a PC to the LAN port of HandyTone-488.
5. Insert the power adapter into the HandyTone-488 and connect it to a wall outlet.

Please follow the instructions in section 6.2.1 to configure the HandyTone-488.

3 What is Included in the Package

The HandyTone-488 package contains:

- 1) One HandyTone-488
- 2) One universal power adaptor
- 3) One Ethernet cable

3.1 Safety Compliances

The HandyTone-488 is compliant with various safety standards including FCC/CE and C-tick. Its power adaptor is compliant with UL standard. The HandyTone-488 should only operate with the universal power adaptor provided in the package.

Warning: Please do not attempt to use a different power adaptor. Using other power adaptor may damage the HandyTone-488 and will void the manufacturer warranty.

Caution: Changes or modifications to this product not expressly approved by Grandstream, or operation of this product in any way other than as detailed by this User Manual, could void your manufacturer warranty.

Information in this document is subject to change without notice. No part of this document may be reproduced or transmitted in any form or by any means, electronic or mechanical, for any purpose without the express written permission of Grandstream Networks, Inc..

4 Product Overview

4.1 Key Features

- Supports SIP 2.0(RFC 3261), TCP/UDP/IP, RTP/RTCP, HTTP, ICMP, ARP/RARP, DNS, DHCP (both client and server), NTP, PPPoE, STUN, TFTP, etc.
- Built-in router, NAT, Gateway and DMZ port forwarding
- Supports call origination and termination from/to the PSTN network (via FXO port)
- Powerful digital signal processing (DSP) to ensure superb audio quality; advanced adaptive jitter control and packet loss concealment technology
- Support various vocoders including G.711 (a-law and u-law), G.723.1 (5.3K/6.3K), G.726 (40K/32K/24K/16K), as well as G.728, G.729A/B, and iLBC.
- Support Caller ID/Name display or block, Hold, Call Waiting/Flash, Call Transfer, Call Forward, in-band and out-of-band DTMF, Dial Plans, etc.
- Support fax pass through
- Support Silence Suppression, VAD (Voice Activity Detection), CNG (Comfort Noise Generation), Line Echo Cancellation (G.168), and AGC (Automatic Gain Control)
- Support standard encryption and authentication (DIGEST using MD5 and MD5-sess)
- Support for Layer 2 (802.1Q VLAN, 802.1p) and Layer 3 QoS (ToS, DiffServ, MPLS)
- Support automated NAT traversal without manual manipulation of firewall/NAT
- Support device configuration via built-in IVR, Web browser or central configuration file through TFTP or HTTP
- Support firmware upgrade via TFTP or HTTP with encrypted configuration files.
- Ultra compact (wallet size) and lightweight design, great companion for travelers
- Compact, lightweight Universal Power adapter.

4.2 Hardware Specification

The table below describes the difference among these models.

<u>Model</u>	<u>HandyTone-488</u>
LAN interface	1xRJ45 10Base-T
WAN interface	1xRJ45 10Base-T
FXS telephone port	1xFXS
FXO port	1xFXO
Button	1
LED	Green and red color
Universal Switching Power Adaptor	Input: 100-240VAC 50-60 Hz Output: +5VDC, 1200mA, UL certified
Dimension	70mm (W) 130mm (D) 27mm (H)
Weight	0.6lbs (0.3kg)
Temperature	40 - 130°F 5 - 45°C
Humidity	10% - 90% (non-condensing)
Compliance	

5 Basic Operations

5.1 Get Familiar with Voice Prompt

HandyTone-488 has stored a voice prompt menu for quick browsing and simple configuration.

To enter this voice prompt menu, simply **press the button or “****” from the analog phone.**

Menu	Voice Prompt	User's Options
Main Menu	“Enter a Menu Option”	Enter “*” for the next menu option Enter “#” to return to the main menu Enter 01-06, 47, 86, 99 menu option
01	“DHCP Mode”, “Static IP Mode”	Enter “9” to toggle the selection
02	“IP Address “ + IP address	The current WAN IP address is announced Enter 12 digit new IP address if in Static IP Mode
03	“Subnet “ + IP address	Same as menu 02
04	“Gateway “ + IP address	Same as menu 02
05	“DNS Server “ + IP address	Same as menu 02
06	“TFTP Server “ + IP address	Same as menu 02
47	“Direct IP Calling”	When entered, you will be prompted a dial tone, then enter 12 digit IP address This menu can also be entered by pressing the button again
86	“Voice Messages Pending” “No Voice Messages”	Enter “9” to dial pre-configured phone number to retrieve VM
99	“RESET”	Enter “9” to reboot the phone Enter encoded MAC address to restore factory default setting
	“Invalid Entry”	Automatically returns to main menu

Notes:

- Once the button is pressed, it enters the voice prompt main menu. If the button is pressed again, while it is already in the voice prompt menu, it jumps to “*Direct IP Call*” option and a dial tone is prompted
- “*” always shifts down to the next menu option
- “#” always returns to the main menu
- “9” functions as the ENTER key in many cases to confirm an option
- All entered digit sequences have known lengths - 2 digits for menu option and 12 digits for IP address. Once all of the digits are collected, the input will be processed.
- Key entry can not be deleted but the phone may prompt error once it is detected

5.2 Make Phone Calls

5.2.1 Calling phone or extension numbers

To make a phone or extension number call:

a) Dial the number directly and wait for 4 seconds (default “No Key Entry Timeout”) .

Or

b) Dial the number directly, and press # (assuming that “Use # as dial key” is selected in web configuration).

Other functions available during the call are call-waiting/flash, call-transfer, and call-forward.

5.2.2 Direct IP calls

Direct IP calling allows two phones, that is, a HandyTone with an analog phone and another VoIP Device, to talk to each other in an ad hoc fashion without a SIP proxy. VoIP calls can be made between two phones if:

- Both HandyTone ATA and the other VoIP device (i.e., another HandyTone ATA or other SIP products) have public IP addresses, or
- Both HandyTone ATA and the other VoIP device (i.e., another HandyTone ATA or other SIP produces) are on the same LAN using private or public IP addresses, or
- Both HandyTone ATA and the other VoIP device (i.e., another HandyTone ATA or other SIP products) can be connected through a router using public or private IP addresses.

To make a direct IP call, first pick up the analog phone or turn on the speakerphone on the analog phone, then follow Section 5.1 with voice prompt 47, followed by the 12-digit target IP address. Destination ports can be specified by using “*4” (encoding for “:”) followed by the encoded port number. Following is a table of the encoding scheme for the most commonly used characters:

Input	Meaning
00	0
01	1
02	2
03	3
04	4
05	5
06	6
07	7
08	8
09	9
*0	. (dot character)

*4

: (column character)

Examples:

If the target IP address is 192.168.0.160, the dialing convention is

Voice Prompt with option 47, then 192168000160

followed by pressing the “#” key if it is configured as a send key or wait 4 seconds. In this case, the default destination port 5060 is used if no port is specified.

If the target IP address/port is 192.168.1.20:5062, then the dialing convention would be:

Voice Prompt with option 47, then 192168001020*45062 followed by pressing the “#” key if it is configured as a send key or wait for 4 seconds.

5.2.3 Blind Transfer

Assuming that call party A and B are in conversation. A wants to *Blind Transfer* B to C:

1. A presses FLASH (on the analog phone, or Hook Flash for old model phones) to get a dial tone.
2. Then A dials *87 then dials C’s number, and then #(or wait for 4 seconds)
3. A can hang up.

Note: *Call Feature* has to be set to YES.

A can hold on to the phone and wait for one of the three following behaviors:

- A quick confirmation tone (temporarily using the call waiting indication tone) followed by a dial tone. This indicates the transfer is successful (transferee has received a 200 OK from transfer target). At this point, A can either hang up or make another call.
- A quick busy tone followed by a restored call (on supported platforms only). This means the transferee has received a 4xx response for the INVITE and we will try to recover the call. The busy tone is just to indicate to the transferor that the transfer has failed.
- Busy tone keeps playing. This means we have failed to receive the second NOTIFY from the transferee and decided to time out. Note: this does not indicate the transfer has been successful, nor does it indicate the transfer has failed. When transferee is a client that does not support the second NOTIFY (such as our own earlier firmware), this will be the case. In bad network scenarios, this could also happen, although the transfer may have been completed successfully.

5.2.4 Attended Transfer

Assuming that call party A and B are in conversation. A wants to *Attend Transfer* B to C:

1. A presses FLASH (on the analog phone, or Hook Flash for old model phones) to get a dial tone
2. A then dial C's number then # (or wait for 4 seconds). A and C now in conversation.
3. A can hang up.

Note: When intended Transfer failed, if A hangs up, the HandyTone-488 will ring user A again to remind A that B is still on the call, by pressing FLASH or Hook again will restore the conversation between A and B.

5.2.5 Send and Receive PSTN Calls

Users can send and receive calls from PSTN. To receive PSTN calls, simply take the phone off hook when the analog phone rings. To make a PSTN call, first press *00 (or your own PSTN Access Code) to get the PSTN line dial tone and dial the PSTN number.

5.2.6 VoIP-to-PSTN Calls

To make a VoIP-to-PSTN call, users need to dial the FXO SIP account phone number first. A ring tone is played once followed by a dial tone. At this time, users can dial a PSTN telephone number or a mobile telephone number then # (or wait for 4 seconds). The call will be established afterwards. If no PSTN number is entered after the dial tone, HandyTone-488 will hang up automatically in 10 seconds.

5.2.7 PSTN-to-VoIP Calls

To make a PSTN-to-VoIP call, PSTN callers need to originate a call to the FXO port telephone number first. If no one answers the FXS phone after 4 ring tones, a dial tone is played. At this time, users can dial a VoIP telephone number then # (or wait for 4 seconds). The call will be established afterwards. If no VoIP number is entered after the dial tone, HandyTone-488 will hang up automatically in 10 seconds.

5.3 Call Features

5.3.1 Call Features Table

Following table shows the call features of HandyTone-488.

Key	Call Features
*30	Block Caller ID (for all subsequent calls)
*31	Send Caller ID (for all subsequent calls)
*67	Block Caller ID (per call)
*82	Send Caller ID (per call)

*50	Disable Call Waiting (for all subsequent calls)
*51	Enable Call Waiting (for all subsequent calls)
*70	Disable Call Waiting. (Per Call)
*71	Enable Call Waiting (Per Call)
*72	Unconditional Call Forward. To use this feature, dial “*72” and get the dial tone. Then dial the forward number and “#” for a dial tone, then hang up.
*73	Cancel Unconditional Call Forward To cancel “Unconditional Call Forward”, dial “*73” and get the dial tone, then hang up.
*90	Busy Call Forward To use this feature, dial “*90” and get the dial tone. Then dial the forward number and “#” for a dial tone, then hang up.
*91	Cancel Busy Call Forward To cancel “Busy Call Forward”, dial “*91” and get the dial tone, then hang up
*92	Delayed Call Forward To use this feature, dial “*92” and get the dial tone. Then dial the forward number and “#” for a dial tone, then hang up.
*93	Cancel Delayed Call Forward To cancel this Forward, dial “*93” and get the dial tone, then hang up
Flash/Hook	When in conversation, this action will switch to the new incoming call if there is a call waiting indication. When in conversation without an incoming call, this action will switch to a new channel for a new call.

5.3.2 PSTN Pass Through

When HandyTone-488 is out of power, the RJ 11 line jack on the HandyTone-488 side will function as a pass through jack. Users will be able to use the same analog phone for PSTN calls.

5.4 LED Light Pattern Indication

Following tables show the LED light pattern indication.

RED LED always indicates abnormal status	
DHCP Failed or WAN No Cable	Button flashes every 2 seconds (if DHCP is configured)
HandyTone-488 fails to register	Button flashes every 2 seconds (if SIP server is configured)

GREEN LED always indicates normal working status	
Message Waiting Indication	Button flashes every 2 seconds
RINGING	Button flashes at 1/10 second
RINGING INTERVAL	Button flashes every second

6 Configuration Guide

6.1 Configuring HandyTone-488 WAN IP through Voice Prompt

6.1.1 DHCP Mode

Follow section 5.1 with voice menu option 01 to enable HandyTone-488 to use DHCP.

6.1.2 STATIC IP Mode

Follow section 5.1 with voice menu option 01 to enable HandyTone-488 to use STATIC IP mode, then use option 02, 03, 04 to set up HandyTone-488's IP, Subnet Mask, Gateway respectively.

6.2 Configuring HandyTone-488 with Web Browser

HandyTone-488 series ATA has an embedded Web server that will respond to HTTP GET/POST requests. It also has embedded HTML pages that allow users to configure the HandyTone-488 through a Web browser such as Microsoft's IE and AOL's Netscape.

6.2.1 Access the Web Configuration Menu

The HandyTone-488 HTML configuration menu can be accessed via LAN or WAN port:

- From the LAN port use the default LAN gateway IP address:

`http://192.168.2.1`

- The WAN port HTML configuration option is disabled by default from factory. To access the HTML configuration menu from the WAN port, first enable the "WAN side HTTP access" option by accessing the configuration via LAN port. With the WAN side HTTP access enabled, then get the WAN IP address of the HandyTone-488 through section 5.1 with menu option 02. The HandyTone-488's Web Configuration page can be accessed by the following URI via WAN port:

`http://HandyTone-IP-Address,`

where the **HandyTone-IP-Address** is the WAN IP address of the HandyTone-488.

6.2.2 End User Configuration

Once this HTTP request is entered and sent from a Web browser, the HandyTone-488 will respond with the following login screen:

Grandstream Device Configuration

Password

All Rights Reserved Grandstream Networks, Inc. 2004

The password is case sensitive and the factory default password for End User is '123'.

After a correct password is entered in the login screen, the embedded Web server inside the HandyTone-488 will respond with the Configuration page which is explained in details below.

Grandstream Device Configuration

STATUS
BASIC SETTINGS
ADVANCED SETTINGS

End User Password:	<input style="width: 150px; height: 20px;" type="text"/> (purposely not displayed for security protection)
IP Address:	<input type="checkbox"/> dynamically assigned via DHCP (default) or PPPoE (will attempt PPPoE if DHCP fails and following is non-blank)
	PPPoE account ID: <input style="width: 100px;" type="text"/>
	PPPoE password: <input style="width: 100px;" type="text"/>
	Preferred DNS server: <input style="width: 20px; text-align: center;" type="text"/> 0 . <input style="width: 20px; text-align: center;" type="text"/> 0 . <input style="width: 20px; text-align: center;" type="text"/> 0 . <input style="width: 20px; text-align: center;" type="text"/> 0
	<input checked="" type="checkbox"/> statically configured as:
	IP Address: <input style="width: 20px; text-align: center;" type="text"/> 192 . <input style="width: 20px; text-align: center;" type="text"/> 168 . <input style="width: 20px; text-align: center;" type="text"/> 1 . <input style="width: 20px; text-align: center;" type="text"/> 12
	Subnet Mask: <input style="width: 20px; text-align: center;" type="text"/> 255 . <input style="width: 20px; text-align: center;" type="text"/> 255 . <input style="width: 20px; text-align: center;" type="text"/> 255 . <input style="width: 20px; text-align: center;" type="text"/> 0
	Default Router: <input style="width: 20px; text-align: center;" type="text"/> 192 . <input style="width: 20px; text-align: center;" type="text"/> 168 . <input style="width: 20px; text-align: center;" type="text"/> 1 . <input style="width: 20px; text-align: center;" type="text"/> 1
	DNS Server 1: <input style="width: 20px; text-align: center;" type="text"/> 129 . <input style="width: 20px; text-align: center;" type="text"/> 105 . <input style="width: 20px; text-align: center;" type="text"/> 5 . <input style="width: 20px; text-align: center;" type="text"/> 1
	DNS Server 2: <input style="width: 20px; text-align: center;" type="text"/> 204 . <input style="width: 20px; text-align: center;" type="text"/> 127 . <input style="width: 20px; text-align: center;" type="text"/> 198 . <input style="width: 20px; text-align: center;" type="text"/> 4
Time Zone:	<input (us="" central="" chicago)"="" gmt-6:00="" style="width: 100%; height: 20px;" time,="" type="text" value="current setting is "/>
Daylight Savings Time:	<input checked="" type="checkbox"/> No <input type="checkbox"/> Yes (if set to Yes, display time will be 1 hour ahead of normal time)

NAT/DHCP Server Information & Configuration:

Cloned WAN MAC Addr: (in hex format)

LAN Subnet Mask: (default is 255.255.255.0)

LAN DHCP Base IP: (base IP for the LAN port, default is 192.168.2.1)

DHCP IP Lease Time: (in units of hours, default is 120 hours or 5 days)

DMZ IP:

Port Forwarding:

WAN port	<input type="text" value="0"/>	LAN IP	<input type="text"/>	LAN port	<input type="text" value="0"/>	Protocol	"UDP Only" ▼
WAN port	<input type="text" value="0"/>	LAN IP	<input type="text"/>	LAN port	<input type="text" value="0"/>	Protocol	"UDP Only" ▼
WAN port	<input type="text" value="0"/>	LAN IP	<input type="text"/>	LAN port	<input type="text" value="0"/>	Protocol	"UDP Only" ▼
WAN port	<input type="text" value="0"/>	LAN IP	<input type="text"/>	LAN port	<input type="text" value="0"/>	Protocol	"UDP Only" ▼
WAN port	<input type="text" value="0"/>	LAN IP	<input type="text"/>	LAN port	<input type="text" value="0"/>	Protocol	"UDP Only" ▼
WAN port	<input type="text" value="0"/>	LAN IP	<input type="text"/>	LAN port	<input type="text" value="0"/>	Protocol	"UDP Only" ▼
WAN port	<input type="text" value="0"/>	LAN IP	<input type="text"/>	LAN port	<input type="text" value="0"/>	Protocol	"UDP Only" ▼
WAN port	<input type="text" value="0"/>	LAN IP	<input type="text"/>	LAN port	<input type="text" value="0"/>	Protocol	"UDP Only" ▼

All Rights Reserved Grandstream Networks, Inc. 2004

End User Password	This contains the password to access the Web Configuration Menu. This field is case sensitive.
IP Address	<p>There are 2 modes under which the HandyTone ATA can operate:</p> <ul style="list-style-type: none"> - If DHCP mode is enabled, then all the field values for the Static IP mode are not used (even though they are still saved in the Flash memory.) The HandyTone ATA will acquire its IP address from the first DHCP server it discovers from the LAN it is connected. <p>To use the PPPoE feature the PPPoE account settings need to be set. The HandyTone will attempt to establish a PPPoE session if any of the PPPoE fields is set.</p> <ul style="list-style-type: none"> - If Static IP mode is enabled, then the IP address, Subnet Mask, Default Router IP address, DNS Server 1 (primary), DNS Server 2 (secondary) fields will need to be configured. These fields are reset to zero by default.

Time Zone	This parameter controls how the displayed date/time will be adjusted according to the specified time zone.
Daylight Savings Time	This parameter controls whether the displayed time will be daylight savings time or not. If set to Yes, then the displayed time will be 1 hour ahead of normal time.
Cloned WAN MAC Address:	Allow the user to set a specific MAC address. Set in Hex format
LAN Subnet Mask	Sets the LAN subnet mask. Default value is 255.255.255.0
LAN DHCP Base IP:	Base IP for the LAN port which functions as a Gateway for the subnet. Default value is 192.168.2.1
DHCP IP Lease Time:	Value is set in units of hours. Default value is 120hr (5 Days.) The time IP address are assigned to the LAN clients
DMZ IP:	Forward all WAN IP traffic to a specific IP address if no matching port is used by HandyTone-488 itself or in the defined port forwarding.
Port Forwarding:	Allow users to forward a matching (TCP/UDP) port to a specific LAN IP address with a specific (TCP/UDP) port.

In addition to the Basic Settings configuration page, end users also have access to the device Status page. The following is a snap shot of the device Status page. Details will be explained next.

Grandstream Device Configuration	
STATUS BASIC SETTINGS ADVANCED SETTINGS	
MAC Address:	00.0B.82.02.B2.95
WAN IP Address:	192.168.1.12
Product Model:	HT488
Software Version:	Program-- 1.0.0.3 Bootloader-- 1.0.2.22 HTML-- 1.0.0.2 VOC-- 1.0.0.7
System Up Time:	0 day(s) 3 hour(s) 23 minute(s)
Registered:	Yes
PPPoE Link Up:	disabled
	detected NAT type is full cone
All Rights Reserved Grandstream Networks, Inc. 2004	

MAC Address	The device ID, in HEX format. This is a very important ID for ISP troubleshooting.
WAN IP Address	This field shows WAN port IP address.
Product Model	This field contains the product model info.
Software Version	Program: This is the main software release, its number is always used for firmware upgrade. Bootloader: This is normally not changed. HTML: This is the user interface, normally not changed. VOC: This is the codec program, normally not changed.
System Up Time	This field indicates how long the device has been up since the last reboot.
Registered	This field indicates whether the device is registered to the SIP server.
PPPoE Link Up	This field shows whether the PPPoE connection is enabled or not.
Detected NAT Type	This field shows what kind NAT the HandyTone is connected to via its WAN port. It is based on STUN protocol.

6.2.3 Advanced User Configuration

To login to the Advanced User Configuration page, please follow the instructions in section 6.2.1 to get to the following login page. The password is case sensitive and the factory default password for Advanced User is “admin”.

Grandstream Device Configuration

Password

Advanced User configuration includes not only the end user configuration, but also advanced configuration such as SIP configuration, Codec selection, NAT Traversal Setting and other miscellaneous configuration. Following is a snap shot of the advanced configuration page.

Grandstream Device Configuration	
STATUS BASIC SETTINGS ADVANCED SETTINGS	
Admin Password:	<input type="text"/> (purposely not displayed for security protection)
FXS Port:	
SIP Server:	<input type="text" value="sip.mycompany.com"/> (e.g., sip.mycompany.com, or IP address)
Outbound Proxy:	<input type="text"/> (e.g., proxy.myprovider.com, or IP address, if any)
SIP User ID:	<input type="text" value="3320"/> (the user part of an SIP address)
Authenticate ID:	<input type="text" value="3320"/> (can be identical to or different from SIP User ID)
Authenticate Password:	<input type="text"/> (purposely not displayed for security protection)
Name:	<input type="text" value="John Doe"/> (optional, e.g., John Doe)
Register Expiration:	<input type="text" value="60"/> (in minutes. default 1 hour, max 45 days)
local SIP port:	<input type="text" value="5060"/> (default 5060)
local RTP port:	<input type="text" value="5004"/> (1024-65535, default 5004)
Enable Call Features:	<input type="checkbox"/> No <input checked="" type="checkbox"/> Yes (if Yes, Call Forwarding & Call-Waiting-Disable are supported locally)
Send DTMF:	<input checked="" type="checkbox"/> in-audio <input type="checkbox"/> via RTP (RFC2833) <input type="checkbox"/> via SIP INFO
DTMF Payload Type:	<input type="text" value="101"/>
FXO Port:	
SIP Server:	<input type="text" value="sip.mycompany.com"/> (e.g., sip.mycompany.com, or IP address)
Outbound Proxy:	<input type="text"/> (e.g., proxy.myprovider.com, or IP address, if any)
SIP User ID:	<input type="text" value="6602"/> (the user part of an SIP address)
Authenticate ID:	<input type="text" value="6602"/> (can be identical to or different from SIP User ID)
Authenticate Password:	<input type="text"/> (purposely not displayed for security protection)

Name:	<input type="text" value="John Doe"/> (optional, e.g., John Doe)
Register Expiration:	<input type="text" value="60"/> (in minutes. default 1 hour, max 45 days)
local SIP port:	<input type="text" value="5062"/> (default 5062)
local RTP port:	<input type="text" value="5008"/> (1024-65535, default 5008)
Enable Call Features:	<input type="checkbox"/> No <input checked="" type="checkbox"/> Yes (if Yes, Call Forwarding & Call-Waiting-Disable are supported locally)
Send DTMF:	<input checked="" type="checkbox"/> in-audio <input type="checkbox"/> via RTP (RFC2833) <input type="checkbox"/> via SIP INFO
DTMF Payload Type:	<input type="text" value="101"/>
General Settings:	
Misc.	
Preferred Vocoder: (in listed order)	choice 1: <input pcmu\""="" type="text" value="current setting is \"/> choice 2: <input pcma\""="" type="text" value="current setting is \"/> choice 3: <input g723\""="" type="text" value="current setting is \"/> choice 4: <input g729\""="" type="text" value="current setting is \"/> choice 5: <input g726-32\""="" type="text" value="current setting is \"/> choice 6: <input g728\""="" type="text" value="current setting is \"/> choice 7: <input ilbc\""="" type="text" value="current setting is \"/>
Voice Frames per TX:	<input type="text" value="2"/> (up to 10/20/32/64 for G711/G726/G723/other codecs respectively)
G723 rate:	<input checked="" type="checkbox"/> 6.3kbps encoding rate <input type="checkbox"/> 5.3kbps encoding rate
iLBC frame size:	<input checked="" type="checkbox"/> 20ms <input type="checkbox"/> 30ms
iLBC payload type:	<input type="text" value="99"/> (between 96 and 127, default is 98)
Silence Suppression:	<input checked="" type="checkbox"/> No <input type="checkbox"/> Yes
SIP Registration:	<input checked="" type="checkbox"/> Yes <input type="checkbox"/> No
Unregister On Reboot:	<input checked="" type="checkbox"/> Yes <input type="checkbox"/> No
Layer 3 QoS:	<input type="text" value="48"/> (Diff-Serv or Precedence value)
Layer 2 QoS:	802.1Q/VLAN Tag <input type="text" value="0"/> 802.1p priority value <input type="text" value="0"/> (0-7)
Use DNS SRV:	<input checked="" type="checkbox"/> No <input type="checkbox"/> Yes

<i>User ID is phone number:</i>	<input checked="" type="checkbox"/> No <input type="checkbox"/> Yes
<i>Early Dial:</i>	<input checked="" type="checkbox"/> No <input type="checkbox"/> Yes (use "Yes" only if proxy supports 484 response)
<i>Dial Plan Prefix:</i>	<input type="text"/> (this prefix string is added to each dialed number)
<i>No Key Entry Timeout:</i>	<input type="text" value="4"/> (in seconds, default is 4 seconds)
<i>Use # as Dial Key:</i>	<input type="checkbox"/> No <input checked="" type="checkbox"/> Yes (if set to Yes, "#" will function as the "(Re-)Dial" key)
<i>Use random port:</i>	<input checked="" type="checkbox"/> No <input type="checkbox"/> Yes
<i>NAT Traversal:</i>	<input type="checkbox"/> No <input checked="" type="checkbox"/> Yes, STUN server is: <input type="text" value="stun.mycompany.com"/> (URI or IP:port)
<i>keep-alive interval:</i>	<input type="text" value="20"/> (in seconds, default 20 seconds)
<i>Use NAT IP</i>	<input type="text"/> (if specified, this IP address is used in SIP/SDP message)
<i>Proxy-Require:</i>	<input type="text"/> (if specified, the content will appear in Proxy-Require header)
<i>TFTP Upgrade Server:</i>	<input type="text" value="192"/> . <input type="text" value="168"/> . <input type="text" value="1"/> . <input type="text" value="30"/> (for remote software upgrade and configuration)
<i>HTTP Upgrade Server:</i>	<input type="text"/> (IP address or URL)
<i>Auto Upgrade:</i>	<input checked="" type="checkbox"/> No <input type="checkbox"/> Yes, check for new firmware every <input type="text" value="7"/> days (default 7 days)
<i>SUBSCRIBE for MWI:</i>	<input checked="" type="checkbox"/> No, do not send SUBSCRIBE for Message Waiting Indication <input type="checkbox"/> Yes, send periodical SUBSCRIBE for Message Waiting Indication
<i>Offhook Auto-Dial:</i>	<input type="text"/> (User ID/extension to dial automatically when offhook)
<i>Send Flash Event:</i>	<input checked="" type="checkbox"/> No <input type="checkbox"/> Yes (Flash will be sent as a DTMF event if set to Yes)
<i>FXS Impedance:</i>	<input (north="" 600="" america)"="" ohm="" type="text" value="current setting is "/>
<i>Caller ID Scheme:</i>	<input bellcore"="" type="text" value="current setting is "/>
<i>Disable Call-Waiting:</i>	<input type="checkbox"/> No <input checked="" type="checkbox"/> Yes
<i>Polarity Reversal:</i>	<input type="checkbox"/> No <input checked="" type="checkbox"/> Yes (reverse polarity upon call establishment and termination)
<i>NTP Server:</i>	<input type="text" value="time.nist.gov"/> (URI or IP address)
<i>Send Anonymous:</i>	<input type="checkbox"/> No <input checked="" type="checkbox"/> Yes (caller ID will be blocked if set to Yes)
<i>Lock keypad update:</i>	<input type="checkbox"/> No <input checked="" type="checkbox"/> Yes (configuration update via keypad is disabled if set to Yes)
<i>Special Feature:</i>	<input standard"="" type="text" value="current setting is "/>

<i>WAN side http access:</i>	<input type="checkbox"/> No <input checked="" type="checkbox"/> Yes (WAN side access to http server will be rejected if set to No)
<i>PSTN access code:</i>	<input type="text"/> (key pattern to use the PSTN line, default is "*00")
<input type="button" value="Update"/>	
All Rights Reserved Grandstream Networks, Inc. 2004	

Admin Password	This contains the password to access the Advanced Web Configuration page. This field is case sensitive.
SIP Server	SIP Server's URI or IP address
Outbound Proxy	SIP Outbound Proxy Server's URI or IP address
SIP User ID	SIP service subscriber's User ID
Authenticate ID	SIP service subscriber's Authenticate ID. Can be identical to or different from SIP User ID
Authenticate Password	SIP service subscriber's account password
Name	SIP service subscriber's name which will be used for Caller ID display
Register Expiration	This parameter allows the user to specify the time frequency (in minutes) the HandyTone ATA refreshes its registration with the specified registrar. The default interval is 60 minutes (or 1 hour). The maximum interval is 65535 minutes (about 45 days).
Local SIP port	This parameter defines the local SIP port the HandyTone ATA will listen and transmit. The default value for FXS port is 5060. The default value for FXO port is 5062.
Local RTP port	This parameter defines the local RTP-RTCP port pair the HandyTone ATA will listen and transmit. It is the base RTP port for channel 0. When configured, channel 0 will use this port_value for RTP and the port_value+1 for its RTCP; channel 1 will use port_value+2 for RTP and port_value+3 for its RTCP. The default value for FXS port is 5004. The default value for FXO port is 5008.
Enable Call Features	Default is No. If set to Yes, Call Forwarding & Do-Not-Disturb are supported locally
Send DTMF	This parameter controls how DTMF events are transmitted. There are 3 ways: in audio which means DTMF is combined in audio signal (not very reliable with low-bit-rate codec), via RTP (RFC2833), or via SIP INFO.

DTMF Payload Type	This parameter sets the payload type for DTMF using RFC2833
Preferred Vocoder	<p>The HandyTone ATA supports up to 7 different Vocoder types including G.711 A-/U-law, G.723.1, G.726, G.728, G.729A/B, iLBC. Depending on the product model, some of these Vocoders may not be provided in standard release.</p> <p>Users can configure Vocoders in a preference list that will be included with the same preference order in SDP message. The first Vocoder in this list can be entered by choosing the appropriate option in “Choice 1”. Similarly, the last Vocoder in this list can be entered by choosing the appropriate option in “Choice 7”.</p>
Voice Frames per TX	<p>This field contains the number of voice frames to be transmitted in a single packet. When setting this value, the user should be aware of the requested packet time (used in SDP message) as a result of configuring this parameter. This parameter is associated with the first vocoder in the above vocoder Preference List or the actual used payload type negotiated between the 2 conversation parties at run time.</p> <p>e.g., if the first vocoder is configured as G723 and the “Voice Frames per TX” is set to be 2, then the “ptime” value in the SDP message of an INVITE request will be 60ms because each G723 voice frame contains 30ms of audio. Similarly, if this field is set to be 2 and if the first vocoder chosen is G729 or G711 or G726, then the “ptime” value in the SDP message of an INVITE request will be 20ms.</p> <p>If the configured voice frames per TX exceeds the maximum allowed value, the HandyTone ATA will use and save the maximum allowed value for the corresponding first vocoder choice. The maximum value for PCM is 10(x10ms) frames; for G726, it is 20 (x10ms) frames; for G723, it is 32 (x30ms) frames; for G729/G728, 64 (x10ms) and 64 (x2.5ms) frames respectively.</p>
G723 Rate:	This defines the encoding rate for G723 vocoder. By default, 6.3kbps rate is chosen.
iLBC frame size:	This sets the iLBC size in 20ms or 30ms
iLBC payload type:	This defines payload time for iLBC. Default value is 98. The valid range is between 96 and 127.
Silence Suppression	This controls the silence suppression/VAD feature of G723 and G729. If set to “Yes”, when a silence is detected, small quantity of VAD packets (instead of audio packets) will be sent during the period of no talking. If set to “No”, this feature is disabled.
SIP Registration	This parameter controls whether the HandyTone ATA needs to send REGISTER messages to the proxy server. The default setting is “Yes”.

Unregister on Reboot	Default is No. If set to yes, the SIP user will be unregistered on reboot.
Layer 3 QoS	This field defines the layer 3 QoS parameter which can be the value used for IP Precedence or Diff-Serv or MPLS. Default value is 48.
Layer 2 QoS	This contains the value used for layer 2 VLAN tag. Default setting is blank.
Use DNS SRV:	Default is No. If set to Yes the client will use DNS SRV for server lookup
User ID is Phone Number	If the HandyTone ATA has an assigned PSTN telephone number, this field should be set to "Yes". Otherwise, set it to "No". If "Yes" is set, a "user=phone" parameter will be attached to the "From" header in SIP request
Early Dial	Default is No. Use only if proxy supports 484 response
Dial Plan Prefix	Sets the prefix added to each dialed number
No Key Entry Timeout	Default is 4 seconds.
Use # as Send Key	This parameter allows users to configure the "#" key to be used as the "Send" (or "Dial") key. If set to "Yes", pressing this key will immediately trigger the sending of dialed string collected so far. In this case, this key is essentially equivalent to the "(Re)Dial" key. If set to "No", this "#" key will then be included as part of the dial string to be sent out.
Use Random Port	This parameter, when set to Yes, will force random generation of both the local SIP and RTP ports. This is usually necessary when multiple HandyTone ATAs are behind the same NAT.
NAT Traversal	This parameter defines whether the HandyTone ATA NAT traversal mechanism will be activated or not. If activated (by choosing "Yes") and a STUN server is also specified, then the HandyTone ATA will behave according to the STUN client specification. Under this mode, the embedded STUN client inside the HandyTone ATA will attempt to detect if and what type of firewall/NAT it is sitting behind through communication with the specified STUN server. If the detected NAT is a Full Cone, Restricted Cone, or a Port-Restricted Cone, the HandyTone ATA will attempt to use its mapped public IP address and port in all its SIP and SDP messages. If the NAT Traversal field is set to "Yes" with no specified STUN server, the HandyTone ATA will periodically (every 20 seconds or so) send a blank UDP packet (with no payload data) to the SIP server to keep the "hole" on the NAT open.

Keep-alive interval	This parameter specifies how often the HandyTone ATA sends a blank UDP packet to the SIP server in order to keep the “hole” on the NAT open.
Use NAT IP:	NAT IP address used in SIP/SDP message. Default is blank.
Proxy-Require	SIP Extension to notify SIP server that the unit is behind the NAT/Firewall.
TFTP Upgrade Server	This is the IP address of the configured TFTP server. If it is non-zero or not blank, the HandyTone ATA will attempt to retrieve new configuration file or new code image from the specified TFTP server at boot time. It will make up to 3 attempts before timeout and then it will start the boot process using the existing code image in the Flash memory. If a TFTP server is configured and a new code image is retrieved, the new downloaded image will be verified and then saved into the Flash memory.
HTTP Upgrade Server	The URL for the HTTP server used for firmware upgrade and configuration via HTTP. For example, http://provisioning.mycompany.com:6688/Grandstream/1.0.5.16 Here “:6688” is the specific TCP port that the HTTP server is listening at, it can be omitted if using default port 80. Note: Auto Upgrade has to be set to Yes to enable HTTP upgrade.
Auto Upgrade	Choose Yes to enable HTTP upgrade and provisioning. In “Check for new firmware every” field, enter the number of days to check the HTTP server for firmware upgrade or configuration.
Subscribe for MWI:	Default is NO. When set to “Yes” a SUBSCRIBE for Message Waiting Indication will be sent periodically.
Offhook Auto-Dial	This parameter allows users to configure a User ID or extension number to be automatically dialed upon offhook. Please note that only the user part of a SIP address needs to be entered here. The HandyTone ATA will automatically append the “@” and the host portion of the corresponding SIP address.
Send Flash Event	This parameter allows users to control whether to send an SIP NOTIFY message indicating the Flash event, or just to switch to the voice channel when users press the Flash key.
FXS Impedance	Selects the impedance of the analog telephone connected to the Phone port.
Caller ID Scheme	<ul style="list-style-type: none"> • Bellcore (North America) • ETSI-FSK (France, Germany, Norway, Taiwan, UK-CCA) • ETSI-DTMF (Finland, Sweden) • DTMF (Denmark)

Disable Call Waiting	Default is No.
Polarity Reversal	Default is No. If set to Yes, polarity will be reversed upon call establishment and termination.
NTP server	This parameter defines the URI or IP address of the NTP server which is used by the HandyTone ATA to display the current date/time.
Send Anonymous	If this parameter is set to "Yes", the "From" header in outgoing INVITE message will be set to anonymous, essentially blocking the Caller ID from displaying.
Lock keypad update	If this parameter is set to "Yes", the configuration update via keypad is disabled.
Special Feature	<ul style="list-style-type: none">• Standard• Nortel MCS• Broadsoft• Howdy
WAN side http access	If this parameter is set to "No", the HTML configuration update via WAN port is disabled.
PSTN access code	This field allows users to customize their own code to access the PSTN line. Default is "*00".

6.2.4 Saving the Configuration Changes

Once a change is made, users should press the “Update” button in the Configuration page. The HandyTone-488 will then display the following screen to confirm that the changes have been saved.

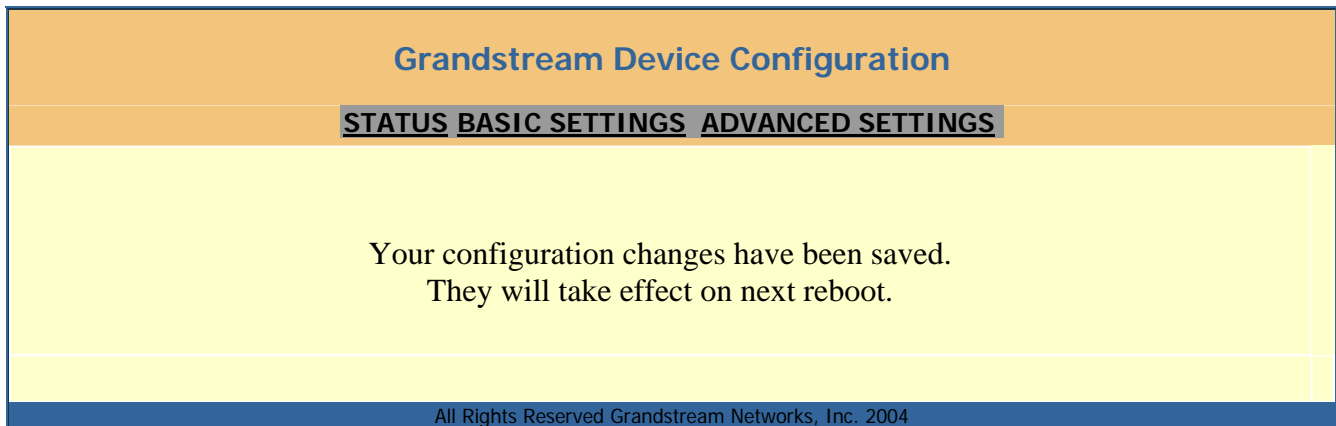

Users are recommended to power cycle the HandyTone-488 after seeing the above message.

6.2.5 Rebooting the HandyTone-488 from Remote

The administrator of the HandyTone-488 can remotely reboot the HandyTone ATA by pressing the “Reboot” button at the bottom of the configuration page. Once done, the following screen will be displayed to indicate that rebooting is underway.



At this point, the user can relogin to the HandyTone-488 after waiting for about 30 seconds.

6.3 Configuration through a Central Server

Grandstream HandyTone ATAs can be automatically configured from a central provisioning system.

When HandyTone ATA boot up, it will send TFTP or HTTP request to download configuration files, there are two configuration files, one is "cfg.txt" and the other is "cfg000b82xxxxxx", where "000b82xxxxxx" is the MAC address of the HandyTone ATA. For more information regarding configuration file format, please refer to the related Grandstream documentation.

The configuration file can be downloaded via TFTP or HTTP from the central server. A service provider or an enterprise with large deployment of HandyTone ATAs can easily manage the configuration and service provisioning of individual devices remotely and automatically from a central server. GAPS (Grandstream Automated Provisioning System) uses enhanced (NAT friendly) TFTP or HTTP (thus no NAT issues) and other communication protocols to communicate with each individual HandyTone ATA for firmware upgrade, remote reboot, etc.

Grandstream provides a licensed provisioning system called GAPS that can be used to support automated configuration of HandyTone ATA. To enable this feature on the HandyTone ATA, a user just needs to enter the IP address of the GAPS server in the TFTP server field of the configuration screen, or enter the HTTP provisioning Server URL in the HTTP Upgrade Server field. Then reboot the HandyTone ATA.

For details on how GAPS works, please refer to the documentation of GAPS product.

7 Software Upgrade

7.1 Upgrade through HTTP

To upgrade software, HandyTone-488 can be configured with an HTTP server where the new code image file is located. For example, following URL in the HTTP Upgrade Server:

```
http://firmware.mycompany.com:6688/Grandstream/1.0.0.4
```

Where `firmware.mycompany.com` is the FQDN of the HTTP server, `“:6688”` is the TCP port the HTTP server listening to, `“/Grandstream/1.0.0.4”` is the RELATIVE directory to the root dir in HTTP server. Thus, you can put different firmware into different directory as well.

Note: To enable HTTP firmware upgrade, “Auto Upgrade” field has to be set to Yes. In addition, the ATA will check the HTTP server in the number of days that is defined in “Check for new firmware every” field.

7.2 Upgrade through TFTP

To upgrade software, HandyTone-488 can be configured with a TFTP server where the new code image is located. The TFTP upgrade can work in either static IP or DHCP mode using private or public IP address. It is recommended to set the TFTP server address in either a public IP address or on the same LAN with the HandyTone-488.

There are two ways to set up the TFTP server to upgrade the firmware, namely through voice menu prompt or via the HandyTone-488’s Web configuration interface. To configure the TFTP server via voice prompt, follow section 5.1 with option 06, once set up the TFTP IP address, power cycle the ATA, the firmware will be fetched once the ATA boots up.

To configure the TFTP server via the Web configuration interface, open up your browser to point at the IP address of the HandyTone-488. Input the admin password to enter the configuration screen. From there, enter the TFTP server address in the designated field towards the bottom of the configuration screen.

Once the TFTP server is configured, power cycle the HandyTone-488.

TFTP checking is only performed during the initial power up. If the configured TFTP server is found and a new code image is available, the HandyTone-488 will attempt to retrieve the new image files by downloading them into the HandyTone-488’s SRAM. During this stage, the HandyTone-488’s LED will blink until the checking/downloading process is completed. Upon verification of checksum, the new code image will then be saved into the Flash. If TFTP fails for any reason (e.g., TFTP server is not responding, there are no code image files available for upgrade, or checksum test fails, etc), the HandyTone-488 will stop the TFTP process and simply boot using the existing code image in the flash.

TFTP process may take as long as 1 to 2 minutes over the Internet, or just 20+ seconds if it is performed on a LAN. Users are recommended to conduct TFTP upgrade in a controlled LAN

environment if possible. For those who do not have a local TFTP server, Grandstream provides a NAT-friendly TFTP server on the public Internet for firmware upgrade. Please check the Service or Support section of Grandstream's Web site to obtain this TFTP server's IP address.

8 Restore Factory Default Setting

Warning: Restore the Factory Default Setting will delete all configuration information of the device.

Please disconnect network cable and power cycle the unit before trying to reset the unit to factory default. The steps are as follows:

A. Find the MAC address of the device. It is a 12 digits number located on the bottom of the unit.

B. Encode the MAC address. Please use the following mapping:

0-9: 0-9

A: 22

B: 222

C: 2222

D: 33

E: 333

F: 3333

For example, 000B82004D2A will be encoded to 00022228200433222.

C. To perform factory reset:

1. Press “****” or the LED button for voice prompt.
2. Enter “99” and get the voice prompt “Reset”.
3. Enter the encoded MAC address of the device. A "click" sound will be heard.
4. Wait for 15 seconds.

The device is now restored to the factory default setting.

Free Manuals Download Website

<http://myh66.com>

<http://usermanuals.us>

<http://www.somanuals.com>

<http://www.4manuals.cc>

<http://www.manual-lib.com>

<http://www.404manual.com>

<http://www.luxmanual.com>

<http://aubethermostatmanual.com>

Golf course search by state

<http://golfingnear.com>

Email search by domain

<http://emailbydomain.com>

Auto manuals search

<http://auto.somanuals.com>

TV manuals search

<http://tv.somanuals.com>