

Out Of Wall Combination FIRE SMOKE DAMPERS

Steel 3V Blades

UL 555S Leakage Class II

UL555 1½ Hour Fire Resistance Rating

Horizontal or Vertical Mount

APPLICATION

Model OFSD-212 is an 'out of the wall' high performance combination fire smoke damper with 3V style blades. OFSD-212 is approved for use in walls, partitions, and floors with fire resistance ratings less than 3 hours. Removal of wall grille allows access to actuator and other components. This model's operational ratings of 2000 fpm (10.2 m/s) and pressures to 4 in. wg (1 kPa). OFSD-212 shall be installed vertically (with blades running horizontal) or horizontally and is rated for airflow and leakage in either direction.

Ratings

UL555 Fire Resistance Rating:

Fire Rating:	1½ hours in walls
Dynamic Closure Rating:	Actual ratings are size dependent
Max. Velocity:	2000 fpm (10.2 m/s)
Max. Pressure:	4 in. wg (1 kPa) - differential pressure

UL555S Leakage Rating:

Leakage Class:	II
Operational Rating:	Actual ratings are size dependent
Max. Velocity:	2000 fpm (10.2m/s)
Max. Pressure:	4 in. wg (1 kPa)
Max. Temperature:	350°F (177°C)- depending upon the actuator

STANDARD CONSTRUCTION

Frame:	5 in. x 1 in. (127mm x 25mm) galvanized steel hat channel with reinforced corners. A low profile head and sill are used on sizes less than 17 in. (432mm) high.
Blades:	16 ga. (1.5mm) galvanized steel, reinforced with 3 longitudinal structurally designed vee's.
Seals:	Extruded silicone rubber blade seals. Flexible stainless steel jamb seals
Linkage:	Concealed in jamb
Closure Device:	UL listed 165°F (74°C) RRL
Axles:	½ in. (13mm) dia. plated steel
Bearings:	Bronze sleeve type
Sleeve:	Galvanized; wrapped with thermal blanket

Size Limitations:

Minimum Size:	12 in. W x 12 in. H (305mm x 305mm)
Maximum Size:	Single section: 36 in. W x 36 in. H (914mm x 914mm)

Optional Features:

- POC retaining Angles
- RRL/OCI (open closed indication switches)
- 165°F (74°C), 212°F (100°C), 250°F (121°C), 350°F (177°C) RRL's available
- TOR (remote override allows damper to perform smoke management functions during fire emergency.)
- Electric actuators
- Momentary switch
- Security bars
- Sealed transition and sleeves

Model OFSD-212 meets the requirements for fire dampers, smoke dampers and combination fire smoke dampers established by:

National Fire Protection Association

NFPA Standards 80, 90A, 92A, 92B, 101 & 105

IBC International Building Codes

ICBO Uniform Building Codes

CSFM California State Fire Marshal

Fire Damper Listing (#3225-0981:103)

Leakage (Smoke) Damper Listing (#3230-0981:104)

New York City (MEA listing #260-91-M)

"UL CLASSIFIED (see complete marking on product)"

"UL CLASSIFIED to Canadian safety standards (see complete marking on product)"

Standard 555 & 555S (Listing #R13317)



Greenheck Fan Corporation certifies that the model OFSD-212 shown herein is licensed to bear the AMCA Seal. The ratings shown are based on tests and procedures performed in accordance with AMCA Publication 511 and comply with the requirements of the AMCA Certified Ratings Programs. The AMCA Certified Ratings Seal applies to air performance ratings only.

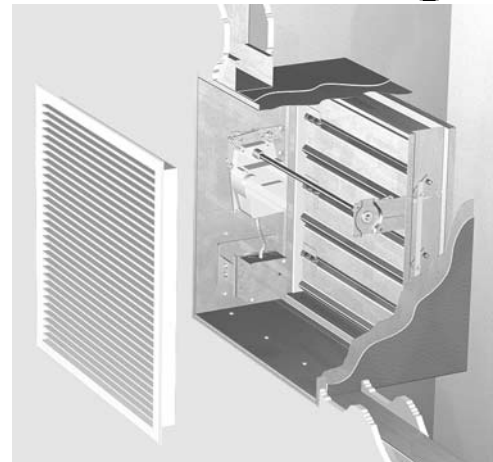

* W & H dimensions furnished approximately ¼ in. (6mm) undersize. (Add blanket thickness (1/8 in.[3mm]) and sleeve thickness for overall sleeved damper dimension)
Oversize wall opening as follows:
Nominal damper size plus 3/8 in.(9.5mm) (see Page 6)

Installation instructions available at www.greenheck.com

This pressure drop testing was conducted in accordance with AMCA Standard 500-D using the three configurations shown. All data has been corrected to represent standard air at a density of .075 lb/ft³ (1.201 kg/m³).

Actual pressure drop found in any HVAC system is a combination of many factors. This pressure drop information along with an analysis of other system influences should be used to estimate actual pressure losses for a damper installed in a given HVAC system.

AMCA Test Figures

Figure 5.3 Illustrates a fully ducted damper. This configuration has the lowest pressure drop of the three test configurations because entrance and exit losses are minimized by straight duct runs upstream and downstream of the damper.

Figure 5.2 Illustrates a ducted damper exhausting air into an open area. This configuration has a lower pressure drop than Figure 5.5 because entrance losses are minimized by a straight duct run upstream of the damper.

Figure 5.5 Illustrates a plenum mounted damper. This configuration has the highest pressure drop because of extremely high entrance and exit losses due to the sudden changes of area in the system.

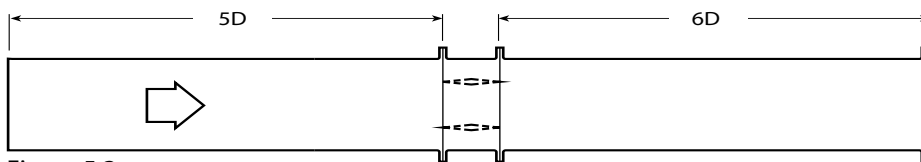

Figure 5.3

Figure 5.3

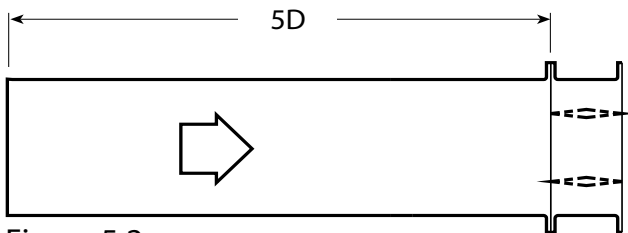

Figure 5.2

Figure 5.2

$$D = \sqrt{\frac{4 (W) (H)}{3.14}}$$

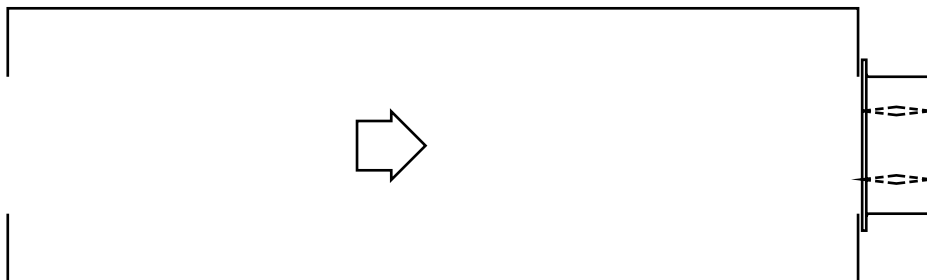

Figure 5.5

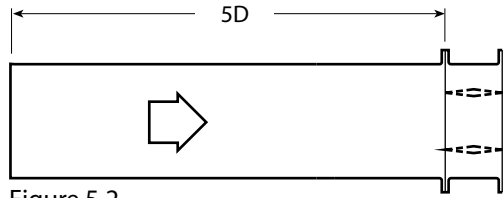
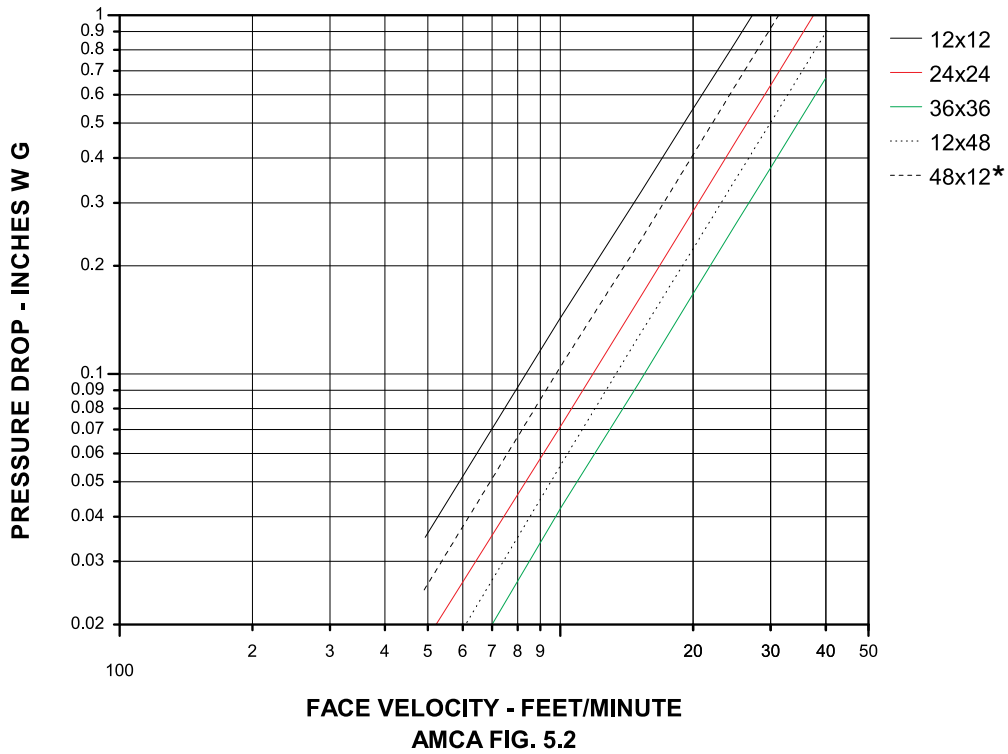

Figure 5.2

VELOCITY VS. PRESSURE DROP



* This size is based on multi-section unit.

12 in. x 12 in. (305mm x 305mm)

Velocity (fpm)	Pressure Drop (in. wg)
500	0.04
1000	0.14
1500	0.31
2000	0.55
2500	0.86
3000	1.24
3500	1.69
4000	2.20

24 in. x 24 in. (610mm x 610mm)

Velocity (fpm)	Pressure Drop (in. wg)
500	0.02
1000	0.07
1500	0.16
2000	0.29
2500	0.45
3000	0.65
3500	0.89
4000	1.16

36 in. x 36 in. (914mm x 914mm)

Velocity (fpm)	Pressure Drop (in. wg)
500	0.01
1000	0.04
1500	0.09
2000	0.16
2500	0.25
3000	0.36
3500	0.49
4000	0.64

12 in. x 48 in. (305mm x 1219mm)

Velocity (fpm)	Pressure Drop (in. wg)
500	0.01
1000	0.06
1500	0.13
2000	0.23
2500	0.36
3000	0.52
3500	0.70
4000	0.92

48 in. x 12 in. (1219mm x 305mm)

Velocity (fpm)	Pressure Drop (in. wg)
500	0.03
1000	0.10
1500	0.23
2000	0.41
2500	0.63
3000	0.91
3500	1.24
4000	1.62



Greenheck Fan Corporation certifies that the model OFSD-212 shown herein is licensed to bear the AMCA Seal. The ratings shown are based on tests and procedures performed in accordance with AMCA Publication 511 and comply with the requirements of the AMCA Certified Ratings Programs. The AMCA Certified Ratings Seal applies to air performance ratings only.

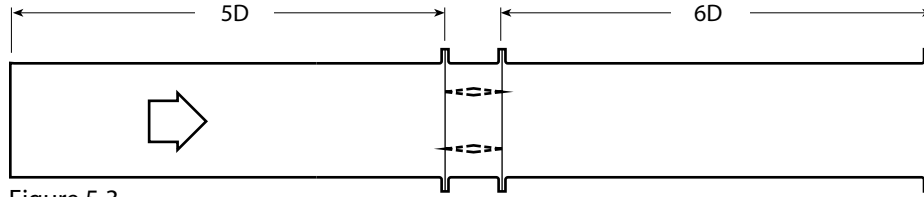
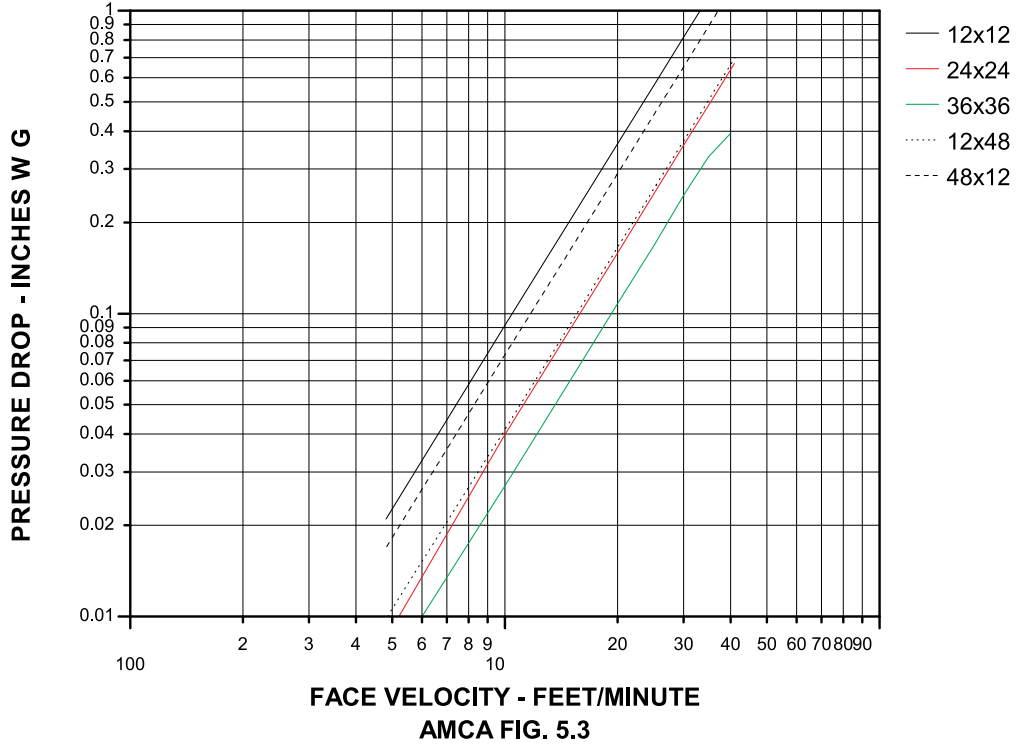

Figure 5.3

VELOCITY VS. PRESSURE DROP



* This size is based on multi-section unit.

12 in. x 12 in. (305mm x 305mm)

Velocity (fpm)	Pressure Drop (in. wg)
500	0.02
1000	0.09
1500	0.20
2000	0.36
2500	0.56
3000	0.81
3500	1.10
4000	1.44

24 in. x 24 in. (610mm x 610mm)

Velocity (fpm)	Pressure Drop (in. wg)
500	0.01
1000	0.04
1500	0.09
2000	0.16
2500	0.25
3000	0.35
3500	0.48
4000	0.63

36 in. x 36 in. (914mm x 914mm)

Velocity (fpm)	Pressure Drop (in. wg)
500	0.01
1000	0.03
1500	0.06
2000	0.11
2500	0.17
3000	0.24
3500	0.33
4000	0.42

12 in. x 48 in. (305mm x 1219mm)

Velocity (fpm)	Pressure Drop (in. wg)
500	0.01
1000	0.04
1500	0.10
2000	0.17
2500	0.27
3000	0.39
3500	0.53
4000	0.70

48 in. x 12 in. (1219mm x 305mm)

Velocity (fpm)	Pressure Drop (in. wg)
500	0.02
1000	0.07
1500	0.16
2000	0.29
2500	0.45
3000	0.64
3500	0.88
4000	1.14



Greenheck Fan Corporation certifies that the model OFSD-212 shown herein is licensed to bear the AMCA Seal. The ratings shown are based on tests and procedures performed in accordance with AMCA Publication 511 and comply with the requirements of the AMCA Certified Ratings Programs. The AMCA Certified Ratings Seal applies to air performance ratings only.

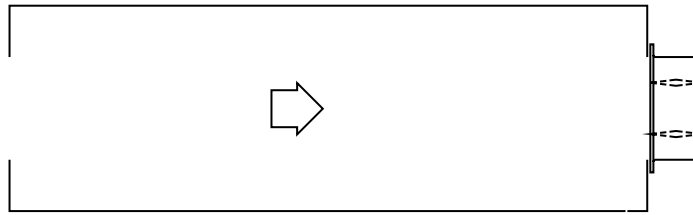

VELOCITY VS. PRESSURE DROP

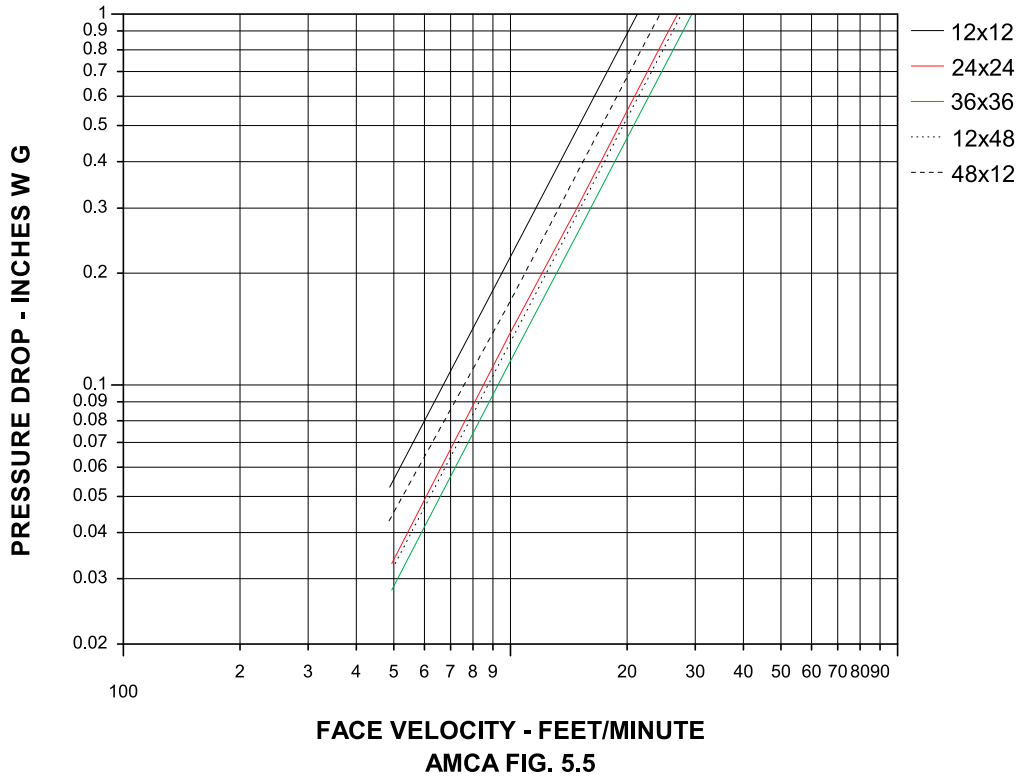

* This size is based on multi-section unit.

12 in. x 12 in. (305mm x 305mm)

Velocity (fpm)	Pressure Drop (in. wg)
500	0.06
1000	0.22
1500	0.50
2000	0.89
2500	1.39
3000	2.00
3500	2.72
4000	3.55

24 in. x 24 in. (610mm x 610mm)

Velocity (fpm)	Pressure Drop (in. wg)
500	0.03
1000	0.14
1500	0.31
2000	0.54
2500	0.85
3000	1.22
3500	1.66
4000	2.17

36 in. x 36 in. (914mm x 914mm)

Velocity (fpm)	Pressure Drop (in. wg)
500	0.03
1000	0.12
1500	0.26
2000	0.46
2500	0.73
3000	1.05
3500	1.42
4000	1.86

12 in. x 48 in. (305mm x 1219mm)

Velocity (fpm)	Pressure Drop (in. wg)
500	0.03
1000	0.13
1500	0.30
2000	0.53
2500	0.83
3000	1.19
3500	1.62
4000	2.11

48 in. x 12 in. (1219mm x 305mm)

Velocity (fpm)	Pressure Drop (in. wg)
500	0.04
1000	0.17
1500	0.38
2000	0.67
2500	1.04
3000	1.50
3500	2.05
4000	2.67



Greenheck Fan Corporation certifies that the model OFSD-212 shown herein is licensed to bear the AMCA Seal. The ratings shown are based on tests and procedures performed in accordance with AMCA Publication 511 and comply with the requirements of the AMCA Certified Ratings Programs. The AMCA Certified Ratings Seal applies to air performance ratings only.

Actuator Space Envelopes

The drawing below and corresponding table show the minimum dimensions required for internal actuator mounting on OFSD-212s. The standard mounting locations provide enough space for the mounting of actuators and controls plus allowing space for a grille and duct connection (see **Sleeve Length** below).

Actuator Space Envelopes	Honeywell	
	ML-4XXX series MS4XXX series	MS4120 series
'X' Dimension	5.88 in. (149mm)	5.88 in. (149mm)
Minimum Width	12 in. (305mm)	12 in. (305mm)
Minimum Height	12 in. (305mm)	12 in. (305mm)

Sleeve Information

'Sleeve Length' = Depth of Grille (or Register)
+ X (Actuator: see table above)
+ 5 in. [127mm] (Damper Width)
+ 1.25 in. [31.8mm] (for duct connection)
 (round up to nearest length: 14 in., 16 in., 18 in., or 20 in. [356, 406, 457, 508mm])

'Sleeve Gauge' = 16 Ga. or 20 Ga. (1.5mm or 1mm)

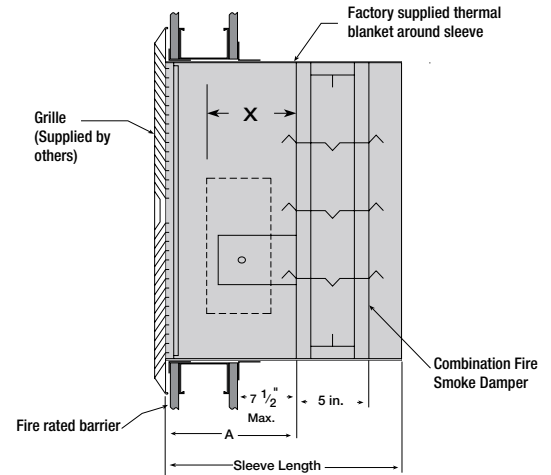

Wall Opening Sizing

To accommodate for sleeve and thermal blanket thickness, the wall opening must be oversized by 3/8 in. (9.5mm) as shown. For example, if the nominal damper size required is 18 in. x 14 in. (457mm x 356mm), the wall opening size needs to be 18 3/8 in. x 14 3/8 in. (467mm x 365mm). The damper itself is undersized 1/4 in. (6mm) on each dimension for an actual damper size of 17 3/4 in. x 13 3/4 in. (451mm x 349mm). This is also the inside dimensions of the sleeve (for grille considerations).

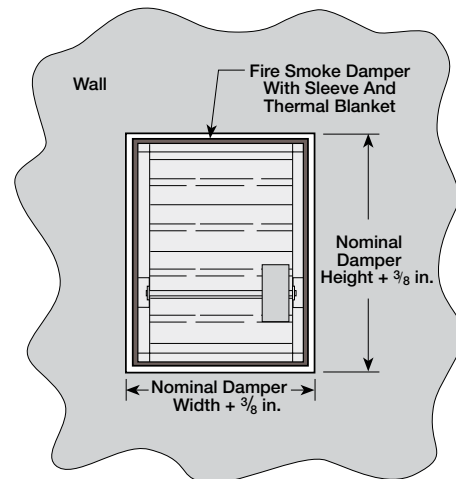

Specifications

Combination Fire Smoke Dampers meeting the following specifications shall be furnished and installed where shown on plans and/or as described in schedules. Dampers shall meet the requirements of NFPA 80, 90A, 92A, 92B, 101 & 105 and further shall be tested, rated and labeled in accordance with the latest edition of UL Standards 555 and 555S. Dampers shall have a UL555 fire rating of 1 1/2 hours and be of low leakage design qualified to UL 555S Leakage Class II.

Each damper/actuator combination shall have a UL555S elevated temperature rating of 250°F (121°C) minimum and shall be operational and dynamic rated to operate at maximum design air flow at its installed location. Each damper shall be supplied with an appropriate actuator installed by the damper manufacturer at the time of damper fabrication. Damper actuator shall be (specifier select one of the following) electric type for 120 (24 or 230) Volt operation.

Damper blades shall be 16 ga. (1.5mm) galvanized steel 3V type with three longitudinal grooves for reinforcement. Damper frame shall be galvanized steel formed into a structural hat channel shape with reinforced corners. Bearings shall be sintered bronze sleeve type rotating in extruded holes in the damper frame. Blade edge seals shall be silicone rubber designed to inflate and provide a tighter seal against leakage as pressure on either side of the damper increases.

Jamb seals shall be stainless steel compression type. Blades shall be completely symmetrical relative to their axle pivot point, presenting identical resistance to airflow in either direction or pressure on either side of the damper. Each damper shall be supplied with a factory mounted sleeve; sleeve shall be wrapped with UL approved thermal barrier material.

The Damper Manufacturer's submittal data shall certify all air performance pressure drop data is licensed in accordance with the AMCA Certified Ratings Program for Test Figures 5.2, 5.3, and 5.5. Damper air performance data shall be developed in accordance with the latest edition of AMCA Standard 500-D. Dampers shall be labeled with the AMCA Air Performance Seal.

Damper must be rated for mounting vertically (with blades running horizontal) or horizontally and be UL 555S rated for leakage and airflow in either direction through the damper. Each damper shall be supplied with a 165°F (74°C) RRL.

The basis of design is Greenheck Model OFSD-212.



Free Manuals Download Website

<http://myh66.com>

<http://usermanuals.us>

<http://www.somanuals.com>

<http://www.4manuals.cc>

<http://www.manual-lib.com>

<http://www.404manual.com>

<http://www.luxmanual.com>

<http://aubethermostatmanual.com>

Golf course search by state

<http://golfingnear.com>

Email search by domain

<http://emailbydomain.com>

Auto manuals search

<http://auto.somanuals.com>

TV manuals search

<http://tv.somanuals.com>