

### Application

Model SSSMD-201 is a 304 stainless steel leakage rated smoke damper with 3V style blades. The SSSMD-201 has been qualified to 2000 fpm (10.2 m/s) and 4 in. wg (1 kPa) for operational closure in emergency smoke control situations. Model SSSMD-201 may be installed vertically (with blades running horizontally) or horizontally and is rated for airflow and leakage in either direction.

### Ratings

<b>Leakage Class:</b>	I
<b>Pressure:</b>	4 in. wg (1 kPa) - differential pressure
<b>Velocity:</b>	Operational rated to 2000 fpm (10.2 m/s)
<b>Temperature:</b>	350°F (177°C) with all actuators. Higher temperature ratings with some actuators.

### Standard Construction

<b>Frame:</b>	5 in. x 1 in. (127mm x 25mm) 16 ga. (1.5mm) 304 stainless steel hat channel with reinforced corners. A low profile head and sill are used on sizes less than 17 in. (432mm) high to maximize free area and performance.
<b>Blades:</b>	16 ga. (1.5mm) 304 stainless steel, reinforced with 3 longitudinal structurally designed vee's.
<b>Seals:</b>	Flexible 304 stainless steel jamb seals.
<b>Linkage:</b>	304 stainless steel - concealed in jamb.
<b>Axles:</b>	1/2 in. (13mm) dia. 304 stainless steel.
<b>Bearings:</b>	304 stainless steel sleeve type.

### Size Limitations

<b>Minimum Size:</b>	8 in. W x 6 in. H (203mm W x 152mm H)
<b>Maximum Size:</b>	
Single Section -	32 in. W x 50 in. H (813mm W x 1270mm H) 36 in. W x 48 in. H (914mm W x 1219mm H)
Multiple Section -	144 in. W x 100 in. H (3658mm W x 2438mm H) 288 in. W x 50 in. H (7315 mm W x 1270mm H)

### Optional Features

- OCI (Open closed indication switches)
- Electric or pneumatic actuators to accomplish smoke management and system functions.
- Fail open

Model SSSMD-201 meets the requirements for smoke dampers established by:

**National Fire Protection Association**

NFPA Standards 92A, 92B, 101 & 105

**IBC International Building Codes**

New York City (MEA listing #260-91-M)

**CSFM California State Fire Marshal**

Leakage (Smoke) Damper Listing (#3230-0981:104)

**"UL CLASSIFIED (see complete marking on product)"**

**"UL CLASSIFIED to Canadian safety standards (see complete marking on product)"**  
Standard 555S (Listing #R13317)



Greenheck Fan Corporation certifies that the model SSSMD-201 shown herein is licensed to bear the AMCA Seal. The ratings shown are based on tests and procedures performed in accordance with AMCA Publication 511 and comply with the requirements of the AMCA Certified Ratings Programs. The AMCA Certified Ratings Seal applies to air performance ratings only.

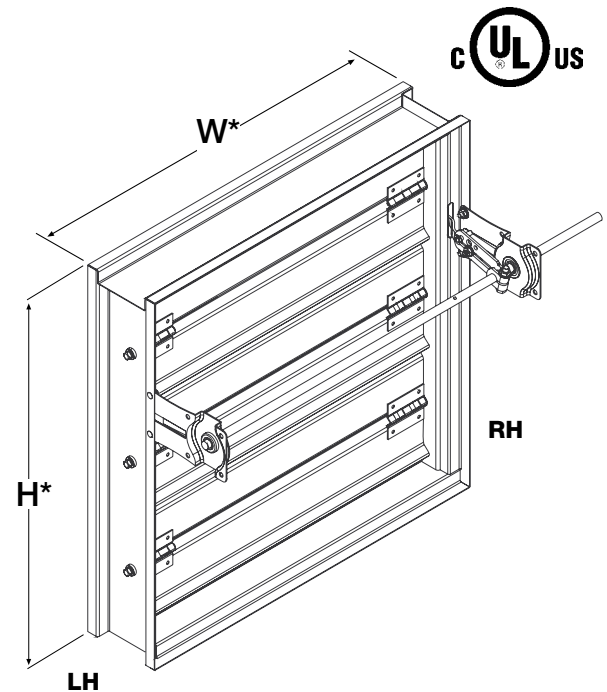

\*W&H dimensions furnished approximately 1/4 in. (6mm) undersize. (Add sleeve thickness for overall sleeved damper dimension)  
Right hand drive is shown. Left hand drive is available upon request.

This pressure drop testing was conducted in accordance with AMCA Standard 500-D using the three configurations shown. All data has been corrected to represent standard air at a density of .075 lb/ft<sup>3</sup> (1.201 kg/m<sup>3</sup>).

Actual pressure drop found in any HVAC system is a combination of many factors. This pressure drop information along with an analysis of other system influences should be used to estimate actual pressure losses for a damper installed in a given HVAC system.

## AMCA Test Figures

**Figure 5.3** Illustrates a fully ducted damper. This configuration has the lowest pressure drop of the three test configurations because entrance and exit losses are minimized by straight duct runs upstream and downstream of the damper.

**Figure 5.2** Illustrates a ducted damper exhausting air into an open area. This configuration has a lower pressure drop than Figure 5.5 because entrance losses are minimized by a straight duct run upstream of the damper.

**Figure 5.5** Illustrates a plenum mounted damper. This configuration has the highest pressure drop because of extremely high entrance and exit losses due to the sudden changes of area in the system.

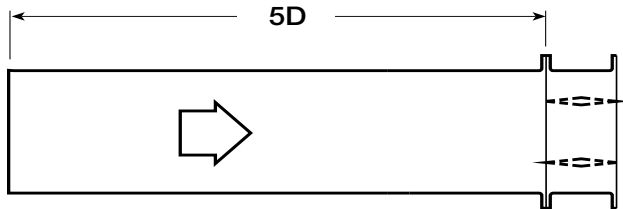
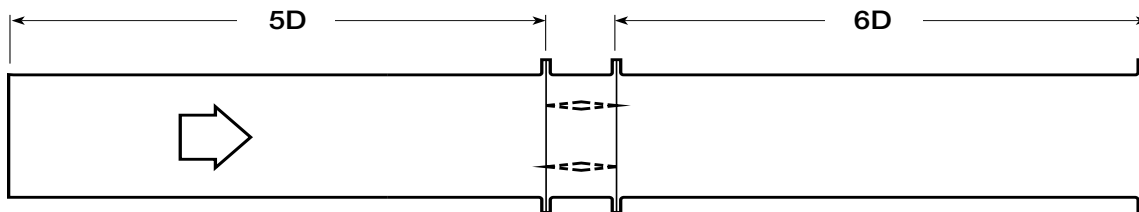

$$D = \sqrt{\frac{4(W)(H)}{3.14}}$$

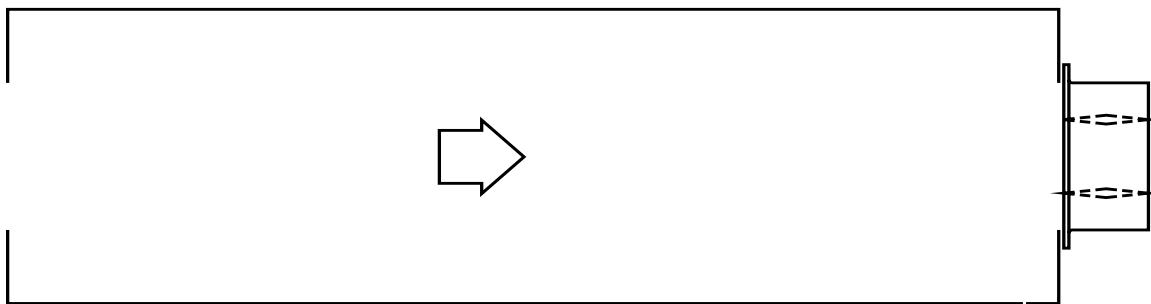

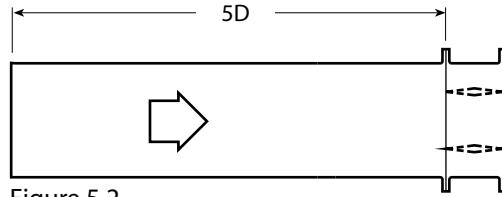
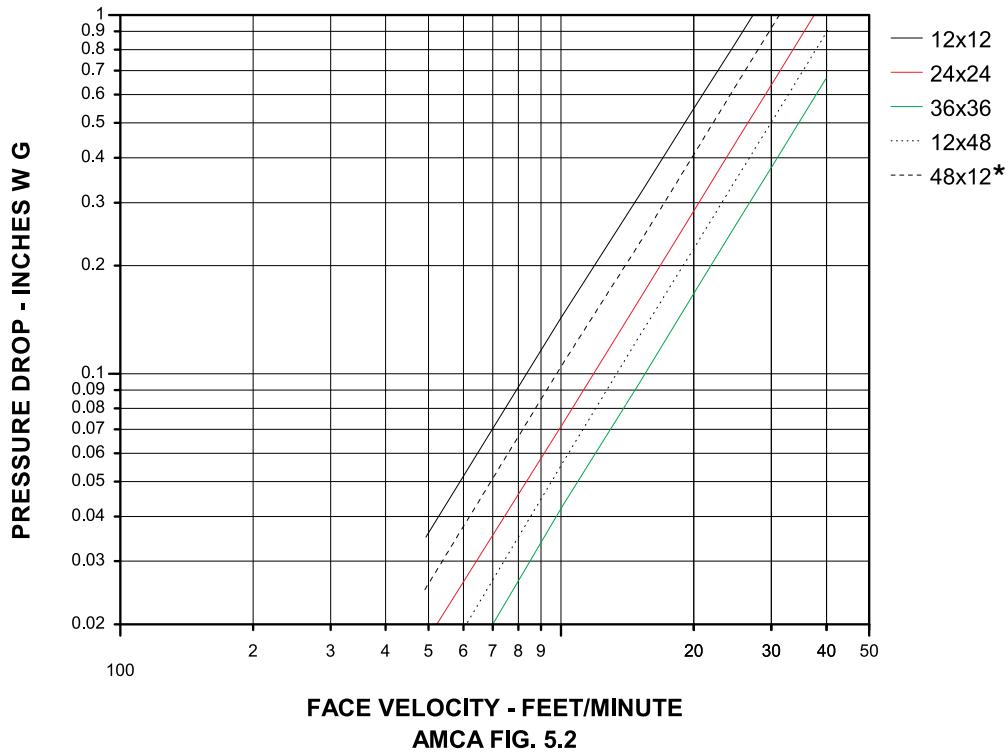

Figure 5.2

### VELOCITY VS. PRESSURE DROP



AMCA FIG. 5.2

12 in. x 12 in. (305mm x 305mm)

Velocity (fpm)	Pressure Drop (in. wg)
500	0.04
1000	0.14
1500	0.31
2000	0.55
2500	0.86
3000	1.24
3500	1.69
4000	2.20

24 in. x 24 in. (610mm x 610mm)

Velocity (fpm)	Pressure Drop (in. wg)
500	0.02
1000	0.07
1500	0.16
2000	0.29
2500	0.45
3000	0.65
3500	0.89
4000	1.16

36 in. x 36 in. (914mm x 914mm)

Velocity (fpm)	Pressure Drop (in. wg)
500	0.01
1000	0.04
1500	0.09
2000	0.16
2500	0.25
3000	0.36
3500	0.49
4000	0.64

12 in. x 48 in. (305mm x 1219mm)

Velocity (fpm)	Pressure Drop (in. wg)
500	0.01
1000	0.06
1500	0.13
2000	0.23
2500	0.36
3000	0.52
3500	0.70
4000	0.92

48 in. x 12 in. (1219mm x 305mm)

Velocity (fpm)	Pressure Drop (in. wg)
500	0.03
1000	0.10
1500	0.23
2000	0.41
2500	0.63
3000	0.91
3500	1.24
4000	1.62



Greenheck Fan Corporation certifies that the model SSSMD-201 shown herein is licensed to bear the AMCA Seal. The ratings shown are based on tests and procedures performed in accordance with AMCA Publication 511 and comply with the requirements of the AMCA Certified Ratings Programs. The AMCA Certified Ratings Seal applies to air performance ratings only.

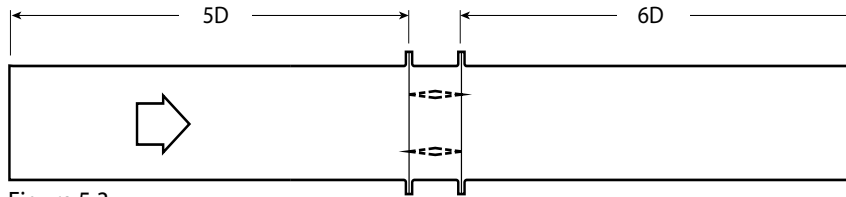
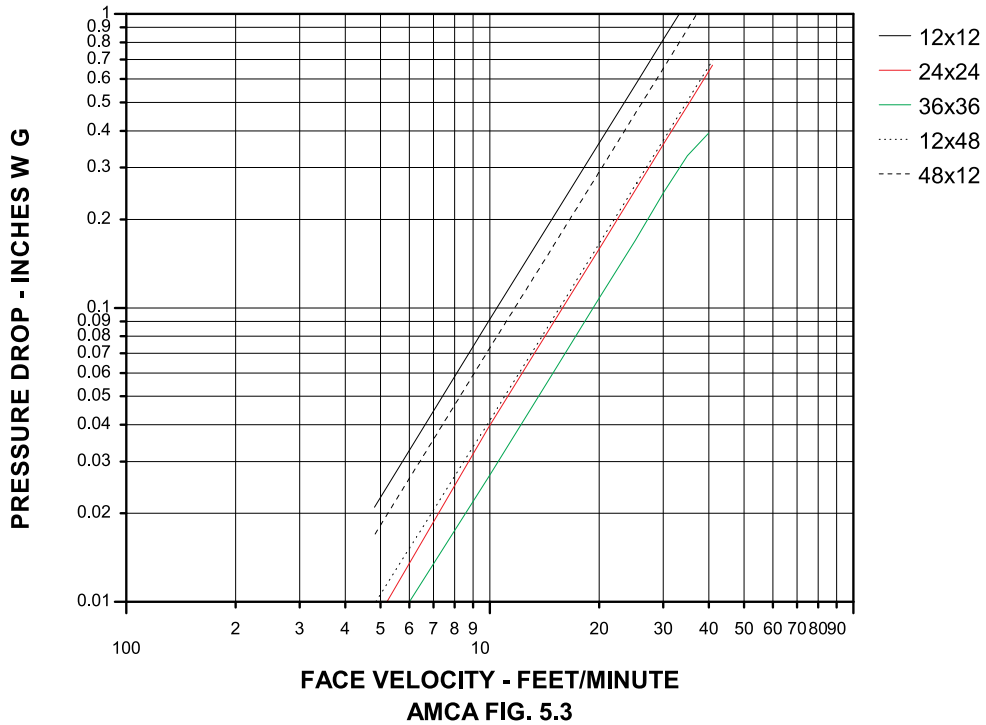

Figure 5.3

### VELOCITY VS. PRESSURE DROP



AMCA FIG. 5.3

12 in. x 12 in. (305mm x 305mm)

Velocity (fpm)	Pressure Drop (in. wg)
500	0.02
1000	0.09
1500	0.20
2000	0.36
2500	0.56
3000	0.81
3500	1.10
4000	1.44

24 in. x 24 in. (610mm x 610mm)

Velocity (fpm)	Pressure Drop (in. wg)
500	0.01
1000	0.04
1500	0.09
2000	0.16
2500	0.25
3000	0.35
3500	0.48
4000	0.63

36 in. x 36 in. (914mm x 914mm)

Velocity (fpm)	Pressure Drop (in. wg)
500	0.01
1000	0.03
1500	0.06
2000	0.11
2500	0.17
3000	0.24
3500	0.33
4000	0.42

12 in. x 48 in. (305mm x 1219mm)

Velocity (fpm)	Pressure Drop (in. wg)
500	0.01
1000	0.04
1500	0.10
2000	0.17
2500	0.27
3000	0.39
3500	0.53
4000	0.70

48 in. x 12 in. (1219mm x 305mm)

Velocity (fpm)	Pressure Drop (in. wg)
500	0.02
1000	0.07
1500	0.16
2000	0.29
2500	0.45
3000	0.64
3500	0.88
4000	1.14



Greenheck Fan Corporation certifies that the model SSSMD-201 shown herein is licensed to bear the AMCA Seal. The ratings shown are based on tests and procedures performed in accordance with AMCA Publication 511 and comply with the requirements of the AMCA Certified Ratings Programs. The AMCA Certified Ratings Seal applies to air performance ratings only.

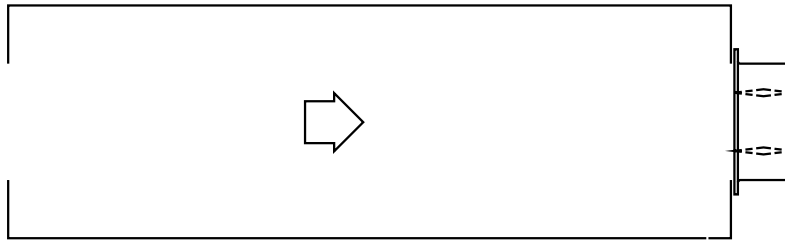

**VELOCITY VS. PRESSURE DROP**

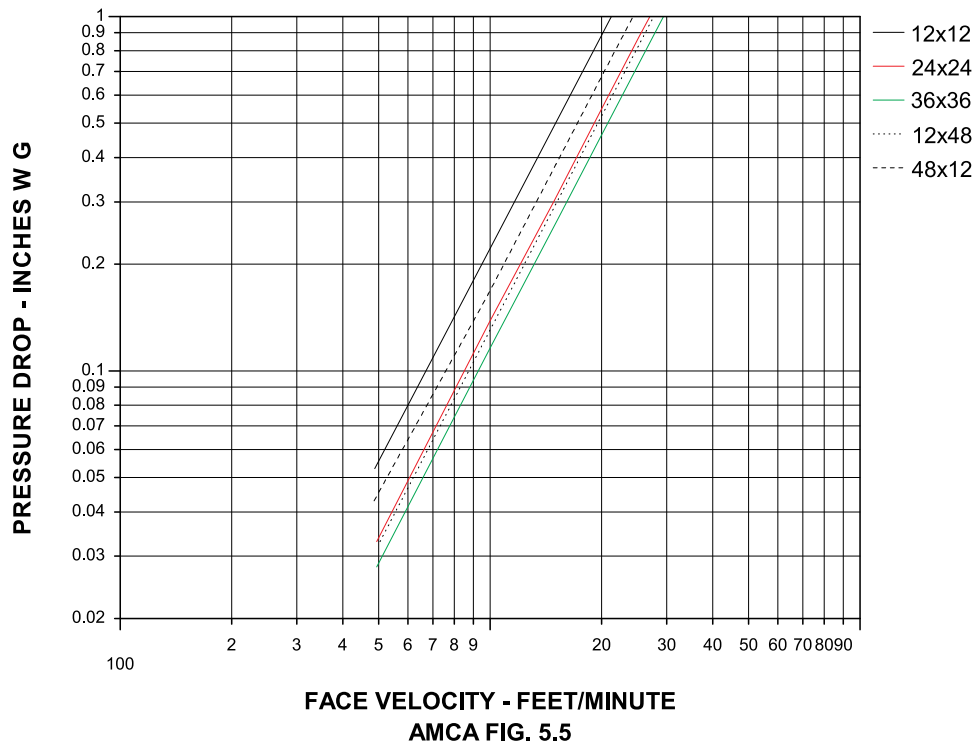

12 in. x 12 in. (305mm x 305mm)

Velocity (fpm)	Pressure Drop (in. wg)
500	0.06
1000	0.22
1500	0.50
2000	0.89
2500	1.39
3000	2.00
3500	2.72
4000	3.55

24 in. x 24 in. (610mm x 610mm)

Velocity (fpm)	Pressure Drop (in. wg)
500	0.03
1000	0.14
1500	0.31
2000	0.54
2500	0.85
3000	1.22
3500	1.66
4000	2.17

36 in. x 36 in. (914mm x 914mm)

Velocity (fpm)	Pressure Drop (in. wg)
500	0.03
1000	0.12
1500	0.26
2000	0.46
2500	0.73
3000	1.05
3500	1.42
4000	1.86

12 in. x 48 in. (305mm x 1219mm)

Velocity (fpm)	Pressure Drop (in. wg)
500	0.03
1000	0.13
1500	0.30
2000	0.53
2500	0.83
3000	1.19
3500	1.62
4000	2.11

48 in. x 12 in. (1219mm x 305mm)

Velocity (fpm)	Pressure Drop (in. wg)
500	0.04
1000	0.17
1500	0.38
2000	0.67
2500	1.04
3000	1.50
3500	2.05
4000	2.67



Greenheck Fan Corporation certifies that the model SSSMD-201 shown herein is licensed to bear the AMCA Seal. The ratings shown are based on tests and procedures performed in accordance with AMCA Publication 511 and comply with the requirements of the AMCA Certified Ratings Programs. The AMCA Certified Ratings Seal applies to air performance ratings only.

# Application Data

## Damper Sideplate and Sleeve Dimensional Data

The drawings below illustrate the factory standard sideplate and sleeve mountings for the SSSMD-201. The standard "A" dimensions listed in the table provide adequate space for the mounting of actuators and controls.

If space constraints are a problem the "A" dimension can be varied between 5 3/8 in. (136mm) and 12 in. (305mm).

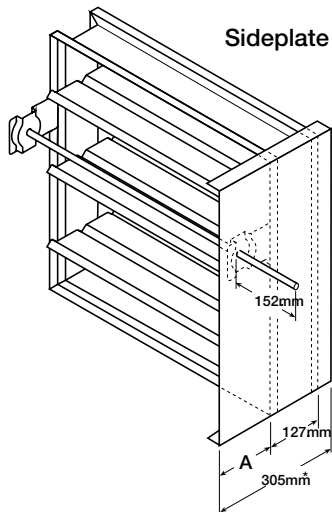

in. (mm)	"A" Dimension	
	Standard	Maximum
All Dampers*	7 3/16 in. (183)	12 (305)
When Height is 11 in. (279) or less with OCI	12 (305)	12 (305)

\*With the exception of dampers 10 in. high (254mm) or less.

NOTE: Entire damper frame is not required to be installed within the wall.

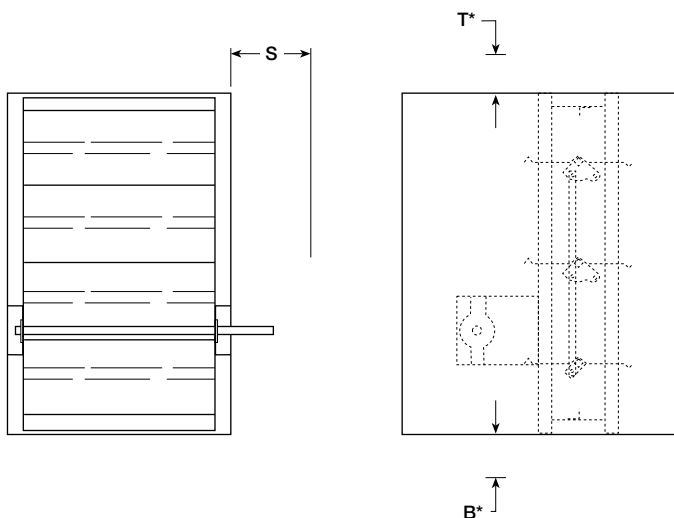
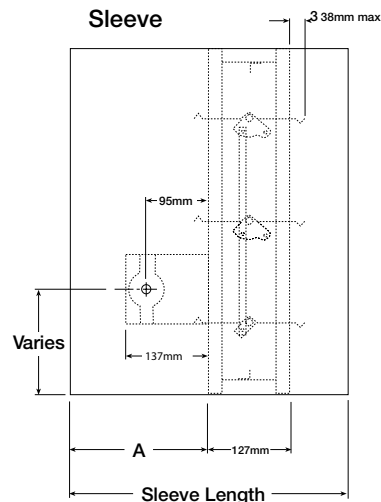

## Space Envelopes Required for Actuators and Accessories

Externally mounted actuators always require space outside of the damper sideplate or sleeve. The "S" dimension illustrates the clearance required for various available actuators.

On dampers less than 18 in. (457mm) high, actuators may also require clearances above and/or below the sideplate or sleeve. "B" and "T" dimensions are worst case clearance requirements for some dampers less than 18 in. (457mm) high. All damper sizes under 18 in. (457mm) high do not require these worst case clearances. If space availability above or below the damper sleeve is limited, each damper size should be individually evaluated.

Actuator Type/Model	B*	T*	S
	With OCI	With OCI	
<b>120 Volt AC</b>			
ML4XXX Series Honeywell	5 1/4 in. (133mm)	3/4 in. (19mm)	6 in. (152mm)
MS4XXX Series Honeywell	6 in. (152mm)	3/8 in. (10mm)	6 in. (152mm)
MS4120 Series Honeywell	6 in. (152mm)	3/8 in. (10mm)	6 in. (152mm)
<b>24 Volt AC</b>			
ML8XXX Series Honeywell	5 1/4 in. (133mm)	3/4 in. (19mm)	6 in. (152mm)
MS8XXX Series Honeywell	6 in. (152mm)	3/8 in. (10mm)	6 in. (152mm)
MS8120 Series Honeywell	6 in. (152mm)	3/8 in. (10mm)	6 in. (152mm)
<b>Pneumatic (psi)</b>			
331-4551 Siemens	1 in. (25mm)	6 1/4 in. (159mm)	6 1/2 in. (165mm)
331-2976 Siemens	2 3/8 in. (60mm)	12 1/8 in. (308mm)	9 1/4 in. (235mm)
MK2-7121 Invensys	3 3/4 in. (95mm)	16 1/2 in. (419mm)	10 in. (254mm)

\* For dampers 18 in. (457mm) or more in height these dimensions are 0 in. .

# Damper Sizing Information

## Damper Sizing Information

Dampers larger than maximum single section size are supplied as a factory assembly of two or more sections of equal size.

The following figures show damper sections and assemblies that have been qualified for operation with a single actuator. Larger sizes can be accommodated using multiples of these assemblies.

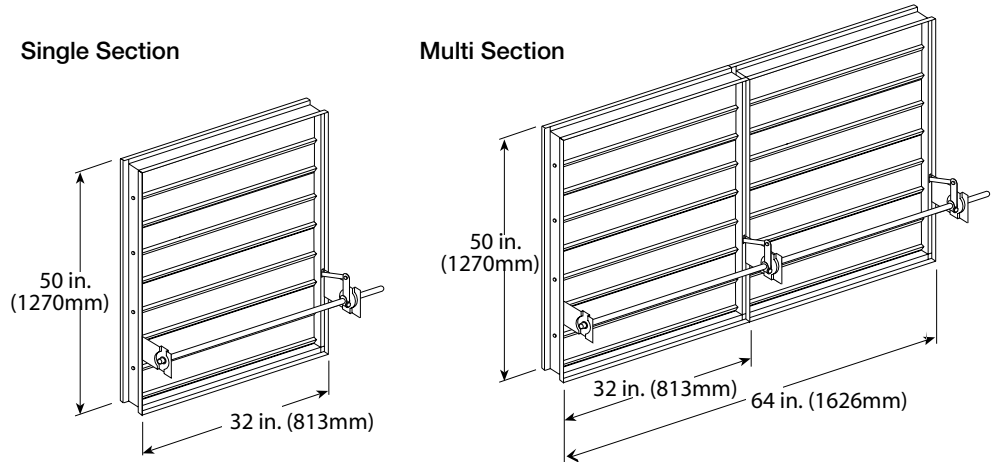

## Transitioned Damper Dimensions

When a fire/smoke damper is being used in conjunction with round or oval ductwork, the SSSMD-201 can be supplied in a factory sleeve with round or oval transitions on both ends of the sleeve. Dampers should be ordered to the duct dimensions. Drawings below show overall damper size.

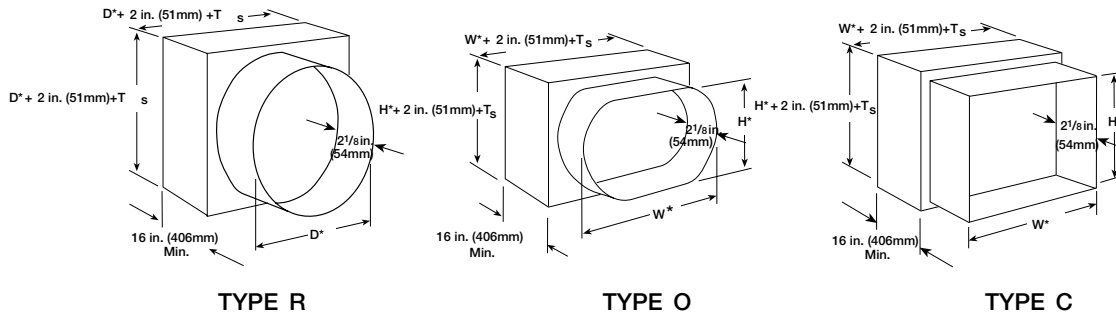

\*These dimensions are furnished approximately 1/4 in. (6mm) undersize, except round and oval dimensions which are approximately 1/8 in. (3mm) undersize.  $T_s = (2)(\text{Sleeve Thickness})$

## Specifications

Smoke Dampers meeting the following specifications shall be furnished and installed where shown on plans and/or as described in schedules. Dampers shall meet the requirements of NFPA 92A, 92B, 101 and 105 and further shall be tested, rated and labeled in accordance with the latest edition of UL Standards 555S. Dampers shall be UL labeled for use in dynamic systems.

Dampers shall have a UL555S leakage rating of Class I and a temperature rating of 250°F (121°C) minimum. Dampers shall have a UL555S operational airflow rating equal to or greater than the airflow at its installed location and an operational pressure rating of 4 in. wg (1 kPa). Damper actuators shall be factory mounted and qualified for use with the damper in accordance with UL555S. Damper actuators shall be (specifier select one of the following) electric type for 120V, 24V, 230 volt operation or pneumatic type for 25 psi minimum (30 psi maximum) operation. Manufacturer's submittal data shall indicate actuator space requirements around the damper.

Damper blades shall be 16 ga. (1.5mm) 304 stainless steel 3V type

with three longitudinal grooves for reinforcement. Blades shall be completely symmetrical relative to their axle pivot point, presenting identical resistance to airflow and operation in either direction through the damper (blades that are non-symmetrical relative to their axle pivot point or utilize blade stops larger than 0.5 in. are unacceptable).

Damper frames shall be 16 ga. (1.5mm) 304 stainless steel formed into a structural hat channel shape with reinforced corners. Bearings shall be stainless steel type rotating in extruded holes in the damper frame. Jamb seals shall be stainless steel compression type.

The Damper manufacturer's submittal data shall certify all air performance pressure drop data is licensed in accordance with the AMCA certified ratings program for test figures 5.2, 5.3, and 5.5. Damper air performance shall be developed in accordance with the latest edition of AMCA Standard 500-D.

The basis of design is Greenheck's model SSSMD-201.



P.O. Box 410 • Schofield, WI 54476-0410 • 715.359.6171 • greenheck.com

Copyright ©2006 Greenheck Fan Corporation  
SSSMD-201 Rev 5 July 2006

## Free Manuals Download Website

<http://myh66.com>

<http://usermanuals.us>

<http://www.somanuals.com>

<http://www.4manuals.cc>

<http://www.manual-lib.com>

<http://www.404manual.com>

<http://www.luxmanual.com>

<http://aubethermostatmanual.com>

Golf course search by state

<http://golfingnear.com>

Email search by domain

<http://emailbydomain.com>

Auto manuals search

<http://auto.somanuals.com>

TV manuals search

<http://tv.somanuals.com>