EM78P221/2N

**8-Bit Microcontroller
with OTP ROM**

**Product
Specification**

DOC. VERSION 1.0

ELAN MICROELECTRONICS CORP.

October 2007



Trademark Acknowledgments:

IBM is a registered trademark and PS/2 is a trademark of IBM.

Windows is a trademark of Microsoft Corporation.

ELAN and ELAN logo  are trademarks of ELAN Microelectronics Corporation.

Copyright © 2007 by **ELAN Microelectronics Corporation**

All Rights Reserved

Printed in Taiwan

The contents of this specification are subject to change without further notice. ELAN Microelectronics assumes no responsibility concerning the accuracy, adequacy, or completeness of this specification. ELAN Microelectronics makes no commitment to update, or to keep current the information and material contained in this specification. Such information and material may change to conform to each confirmed order.

In no event shall ELAN Microelectronics be made responsible for any claims attributed to errors, omissions, or other inaccuracies in the information or material contained in this specification. ELAN Microelectronics shall not be liable for direct, indirect, special incidental, or consequential damages arising from the use of such information or material.

The software (if any) described in this specification is furnished under a license or nondisclosure agreement, and may be used or copied only in accordance with the terms of such agreement.

ELAN Microelectronics products are not intended for use in life support appliances, devices, or systems. Use of ELAN Microelectronics product in such applications is not supported and is prohibited.

NO PART OF THIS SPECIFICATION MAY BE REPRODUCED OR TRANSMITTED IN ANY FORM OR BY ANY MEANS WITHOUT THE EXPRESSED WRITTEN PERMISSION OF ELAN MICROELECTRONICS.



ELAN MICROELECTRONICS CORPORATION

Headquarters:

No. 12, Innovation Road 1
Hsinchu Science Park
Hsinchu, TAIWAN 308
Tel: +886 3 563-9977
Fax: +886 3 563-9966
<http://www.emc.com.tw>

Hong Kong:

Elan (HK) Microelectronics Corporation, Ltd.
Flat A, 19F., World Tech Centre 95
How Ming Street, Kwun Tong
Kowloon, HONG KONG
Tel: +852 2723-3376
Fax: +852 2723-7780
elanhk@emc.com.hk

USA:

Elan Information Technology Group (U.S.A.)
P.O. Box 601
Cupertino, CA 95015
U.S.A.
Tel: +1 408 366-8225
Fax: +1 408 366-8225

Shenzhen:

Elan Microelectronics Shenzhen, Ltd.
3F, SSMEC Bldg., Gaoxin S. Ave. I
Shenzhen Hi-tech Industrial Park
(South Area), Shenzhen
CHINA 518057
Tel: +86 755 2601-0565
Fax: +86 755 2601-0500

Shanghai:

Elan Microelectronics Shanghai, Ltd.
#23, Zone 115, Lane 572, Bibo Rd.
Zhangjiang Hi-Tech Park
Shanghai, CHINA 201203
Tel: +86 21 5080-3866
Fax: +86 21 5080-4600

Contents

EM78P221/2N-V Package version.....	1
EM78P221/2N-U Package version	1
1 General Description	2
2 Features	2
3 Pin Assignment	3
4 Pin Description.....	4
4.1 EM78P222N	4
4.2 EM78P221N	5
5 Block Diagram	6
6 Function Description	7
6.1 Register Configuration.....	7
6.2 Registers Description	8
6.2.1 A (Accumulator).....	8
6.2.2 CONT (Control Register).....	8
6.2.3 R0 (Indirect Addressing Register)	9
6.2.4 R1 (Memory Switch Register)	9
6.2.5 R2 (Program Counter and Stack).....	9
6.2.6 R3 (Status Register).....	10
6.2.7 R4 (Select Indirect Address)	11
6.2.8 Bank 0-R5 (Port 5)	11
6.2.9 Bank 0-R6 (Port 6)	11
6.2.10 Bank 0-R7 (Port 7)	11
6.2.11 Bank 0-R8 (Port 8)	11
6.2.12 Bank 0-R9~RD (Reserve)	11
6.2.13 Bank 0-RE (WUCR: Wake-up Control Register).....	12
6.2.14 Bank 0-RF (Interrupt Status Register).....	12
6.2.15 Bank 1-R5 ~R7 (I/O Port Control Register).....	13
6.2.16 Bank 1-R8 (I/O Port Control Register)	13
6.2.17 Bank 1-R9 (Reserve).....	14
6.2.18 Bank 1-RA (CMPCON: Comparator Control Register)	14
6.2.19 Bank 1-RB (Pull-down Control Register).....	15
6.2.20 Bank 1-RC (Open-Drain Control Register)	15
6.2.21 Bank 1-RD (Pull-high Control Register)	16
6.2.22 Bank 1-RE (WDT Control Register)	16
6.2.23 Bank 1-RF (Interrupt Mask Register)	17
6.2.24 Bank 2-R5 (HDCR: High Drive Control Register for Port 6).....	18
6.2.25 Bank 2-R6 (HSCR1: High Sink Control Register for Port 5)	18
6.2.26 Bank 2-R7 (HSCR2: High Sink Control Register for Port 6)	19



6.2.27	Bank 2-R8 (Operating Mode Control Register).....	19
6.2.28	Bank 2-R9~RF (Reserve).....	19
6.2.29	Bank 3-R5 (Timer Clock/Counter).....	19
6.2.30	Bank 3-R6 (IRC Control)-only for ICE.....	20
6.2.31	Bank 3-R7 (Noise and LVR Control) - only for ICE.....	21
6.2.32	Bank 3-R8~RF (Reserve).....	21
6.2.33	R10 ~ R1F.....	21
6.2.34	Banks 0~3 - R20 ~ R3F.....	21
6.3	TCC/WDT and Prescaler.....	22
6.4	I/O Ports.....	23
6.4.1	Usage of Port 6 Input Change Wake-up/Interrupt Function.....	25
6.5	Reset and Wake-up.....	26
6.5.1	Reset and Wake-up Operation.....	26
6.5.1.1	Wake-up and Interrupt Modes Operation Summary.....	28
6.5.1.2	Register Initial Values after Reset.....	30
6.5.1.3	Controller Reset Block Diagram.....	34
6.5.2	The T and P Status under Status Register.....	35
6.6	Interrupt.....	36
6.7	Comparator.....	38
6.7.1	External Reference Signal.....	38
6.7.2	Comparator Outputs.....	38
6.7.3	Using a Comparator as an Operation Amplifier.....	39
6.7.3.1	Bank 0-RE (WUCR: Wake-up Control Register).....	39
6.7.3.2	Bank 1-RA (CMPCON: Comparator Control Register).....	40
6.7.3.3	Bank 1-RE (WDT Control Register).....	40
6.7.4	Comparator Interrupt.....	40
6.7.5	Wake-up from Sleep Mode.....	40
6.8	Oscillator.....	41
6.8.1	Oscillator Modes.....	41
6.8.2	Crystal Oscillator/Ceramic Resonators (Crystal).....	41
6.8.3	External RC Oscillator Mode.....	44
6.8.4	Internal RC Oscillator Mode.....	45
6.9	Power-on Considerations.....	45
6.9.1	External Power-on Reset Circuit.....	45
6.9.2	Residual Voltage Protection.....	46
6.10	Low Voltage Reset.....	46
6.11	Code Option.....	47
6.11.1	Code Option Register (Word 0).....	47
6.11.2	Code Option Register (Word 1).....	49
6.11.3	Customer ID Register (Word 2).....	50
6.12	Instruction Set.....	50

7	Absolute Maximum Ratings	53
8	DC Electrical Characteristics	53
	8.1 Comparator (OP) Characteristic	55
9	AC Electrical Characteristic	55
10	Timing Diagrams	56

APPENDIX

A	Package Type	57
B	Packaging Configuration	58
	B.1 24-Lead Plastic Skinny Dual in line (SDIP) — 300 mil	58
	B.2 24-Lead Plastic Small Outline (SOP) — 300 mil	59
	B.3 24-Lead Plastic Shrink Small Outline (SSOP) — 209 mil	60
	B.4 28- Lead Plastic Skinny Dual in line (SDIP) — 300 mil	61
	B.5 28-Lead Plastic Small Outline (SOP) — 300 mil	62
	B.6 28- Lead Plastic Shrink Small Outline (SSOP) — 209 mil	63
C	Quality Assurance and Reliability	64
	C.1 Address Trap Detect.....	64



Specification Revision History

Doc. Version	Revision Description	Date
0.9	Preliminary version	2007/03/20
1.0	Initial released version	2007/10/19

Read Me First !

Comparison between V-Package and U-Package version

This series of microcontrollers comprise of the older V-package version and the newer U-package version. In the newer U-package version, a Code Option NRM is added and various features such as Crystal mode Operating frequency range, IRC mode wake-up time, WDT Time-out time, Comparator function and Pins function have been modified to favorably meet users' requirements. The following table is provided for quick comparison between the two package version and for user convenience in the choice of the most suitable product for their application.

	EM78P221/222N-V	EM78P221/222N-U
Crystal mode Operating frequency range at 0°C~ 70°C	DC ~ 12MHz, 4.0V DC ~ 8MHz, 3.0V DC ~ 4MHz, 2.1V	DC ~ 16MHz, 4.5V DC ~ 8MHz, 3.0V DC ~ 4MHz, 2.1V
IRC mode wake-up time Sleep mode → Normal mode Condition: 5V, 4MHz	64μs	10μs
P52, P53 Function	Output only	Input / Output
Comparator Function	Comparator only	Comparator / OPA
WDT Time-out time (Prescaler = 1 : 1) Condition: VDD = 5V	16.5 ms ± 30 %	15.2 ms ± 30 %
Code Option	x	Added a Code Option NRM

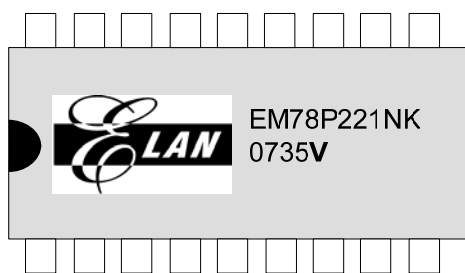

EM78P221/2N-V Package version

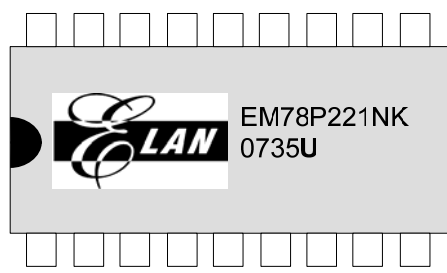

EM78P221/2N-U Package version

1 General Description

EM78P221N and EM78P222N are 8-bit microprocessors designed and developed with low-power and high-speed CMOS technology. Each device in the series has as an on-chip 4K×13-bit Electrical One Time Programmable Read Only Memory (OTP-ROM). Each provides a protection bit to prevent intrusion of user's OTP memory code. Two Code option bits are also available to meet user's requirements.

With its enhanced OTP-ROM features, each device provides a convenient way of developing and verifying user's programs. Moreover, this OTP devices offer the advantages of easy and effective program updates, using development and programming tools. User can avail of the ELAN Writer to easily program his development code.

2 Features

- CPU configuration
 - 4K×13 bits on-chip OTP-ROM
 - 144×8 bits on-chip registers (SRAM)
 - 8-level stacks for subroutine nesting
 - 3 programmable Level Voltage Reset (LVR) : 4.0V, 3.0V, 2.5V
 - Less than 1.5 mA at 5V/4MHz
 - Typically 15 μ A, at 3V/32kHz
 - Typically 2 μ A, during sleep mode
- I/O port configuration
 - 4 bidirectional I/O ports: P5, P6, P7 and P8
 - Wake-up port : P6
 - 26 I/O pins
 - 8 programmable pull-down I/O pins
 - 8 programmable pull-high I/O pins
 - 8 programmable open-drain I/O pins
 - 16 Programmable high sink current I/O pins
 - 8 Programmable high drive current I/O pins
 - External interrupt : P77, P71
- Operating voltage range:
 - OTP version:
 - Operating voltage range: 2.1V~5.5V (commercial)
 - Operating voltage range: 2.3V~5.5V (industrial)
- Operating temperature range:
 - Operating temperature range: 0°C~70°C (commercial)
 - Operating temperature range: -40°C~85°C (industrial)
- Operating frequency range
 - Crystal mode:
 - DC~16MHz/2 clks @ 4.5V; DC~125ns inst. cycle @ 4.5V
 - DC ~ 8MHz/2 clks @ 3V; DC~250ns inst. Cycle @ 3V
 - ERC mode:
 - DC ~ 16MHz/2 clks @ 4.5V; DC~125ns inst. cycle @ 5V
 - DC ~ 8MHz/2 clks @ 3V; DC ~ 250ns inst. Cycle @ 3V
 - IRC mode:
 - Oscillation mode: 16MHz, 4 MHz, 1 MHz, 455kHz
 - Process deviation: Typ \pm 3%, Max. \pm 5%
 - Temperature deviation: \pm 5% (-40°C~85°C)

Internal RC Frequency	Drift Rate			
	Temperature (-40°C+85°C)	Voltage (2.1V~5.5V)	Process	Total
4MHz	\pm 5%	\pm 5%	\pm 4%	\pm 14%
16MHz	\pm 5%	\pm 5%	\pm 4%	\pm 14%
1MHz	\pm 5%	\pm 5%	\pm 4%	\pm 14%
455kHz	\pm 5%	\pm 5%	\pm 4%	\pm 14%

All these four main frequencies can be trimmed by programming with four calibrated bits in the ICE220N Simulator. OTP is auto trimmed by ELAN Writer (DWTR).

- Fast set-up time requires only 800 μ s (VDD:5V, Crystal: 4MHz, C1/C2: 30pF) in HXT2 mode and 10 μ s in IRC mode (VDD:5V IRC:4MHz)
- Peripheral configuration
 - 8-bit real time clock/counter (TCC) with selective signal sources, trigger edges, and overflow interrupt
 - One comparator (can act as an OP). (offset voltage is smaller than 10mV)
- Five available interrupts
 - TCC overflow interrupt
 - Input-port status changed interrupt (wake up from sleep mode)
 - Two External interrupts
 - Comparator high/low interrupt
- Special Features
 - Programmable free running Watchdog Timer
 - Two clocks per instruction cycle
 - Power-on voltage detector available (1.8 V \pm 0.1V)
 - High EFT immunity (better performance at 4MHz or below)
 - Power saving Sleep mode
 - Selectable Oscillation mode
 - Package Type:
 - 24-pin skinny DIP 300mil : EM78P221NKJ/NKS
 - 24 pin SOP 300mil : EM78P221NMJ/NMS
 - 24 pin SSOP 209mil : EM78P221NAMJ/NAMS
 - 28-pin skinny DIP 300mil : EM78P222NKJ/NKS
 - 28 pin SOP 300mil : EM78P222NMJ/NMS
 - 28 pin SSOP 209mil : EM78P222NAMJ/NAMS

3 Pin Assignment

(1) 28-Pin DIP/SOP/SSOP

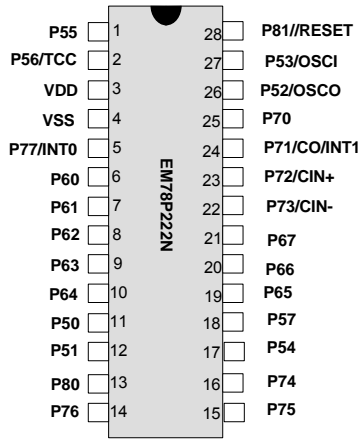

Fig. 3-1 EM78P222NK/AK/M/AM

(2) 24-Pin DIP/SOP/SSOP

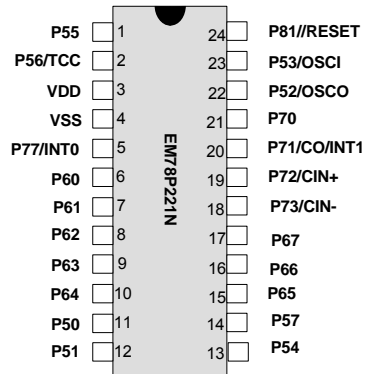

Fig. 3-2 EM78P221NK/M/AM

4 Pin Description

4.1 EM78P222N

Symbol	Pin No.	Type	Function
P50~P57	1~2 11~12 17~18 26~27	I/O	8-bit General purpose input/output pins Default value at power-on reset
P60~P67	6 ~ 10 19 ~21	I/O	8-bit General purpose input/output pins Default value at power-on reset
P70~ P77	5 14 ~ 16 22~25	I/O	8-bit General purpose input/output pins Default value at power-on reset. P72 and P73 are open drain pins when used as output pins in ICE220N simulator.
P80, P81	13, 28	I/O	2-bit General purpose input or output pin Default value at power-on reset P81 is define as General purpose input or output open-drain pin.
CIN- CIN+ CO	22 23 24	I I O	"-" : input pin of Vin- of the comparator "+" : input pin of Vin+ of the comparator Pin CO is the comparator output Defined by CMPCON (Bank 1-RA) <3 : 4>
OSCI	27	I	Crystal type: Crystal input terminal RC type: RC oscillator input pin
OSCO	26	O	Crystal type: Output terminal for crystal oscillator. RC type: Clock output with a duration of one instruction cycle time. External clock signal input.
/RESET	28	I	If it remains at a logic low, the device will be reset Wake-up from sleep mode when pin status changes Voltage on /RESET must not exceed Vdd during normal mode
INT0~INT1	5, 24	I	External interrupt pin
VDD	3	-	Power supply
VSS	4	-	Ground

4.2 EM78P221N

Symbol	Pin No.	Type	Function
P50~P57	1~2 11~14 22~23	I/O	8-bit General purpose input/output pins Default value at power-on reset.
P60~P67	6 ~ 10 15~17	I/O	8-bit General purpose input/output pins Default value at power-on reset
P70~P73 P77	5 21 ~ 18	I/O	5-bit General purpose input/output pins Default value at power-on reset P72 and P73 are open drain pins when used as output pins of the ICE220N simulator.
P81	24	I/O	1-bit General purpose input or output open-drain pin Default value at power-on reset
CIN- CIN+ CO	18 19 20	I I O	"-" : input pin of Vin- of the comparator "+" : input pin of Vin+ of the comparator Pin CO is the comparator output Defined by CMPCON (Bank 1-RA) <3 : 4>
OSCI	23	I	Crystal type: Crystal input terminal RC type: RC oscillator input pin
OSCO	22	O	Crystal type: Output terminal for crystal oscillator RC type: Clock output with a duration of one instruction cycle time. External clock signal input.
/RESET	24	I	If it remains at logic low, the device will be reset Wake-up from sleep mode when pin status changes Voltage on /RESET must not exceed Vdd during normal mode
INT0~INT1	5, 20	I	External interrupt pin
VDD	3	-	Power supply
VSS	4	-	Ground

5 Block Diagram

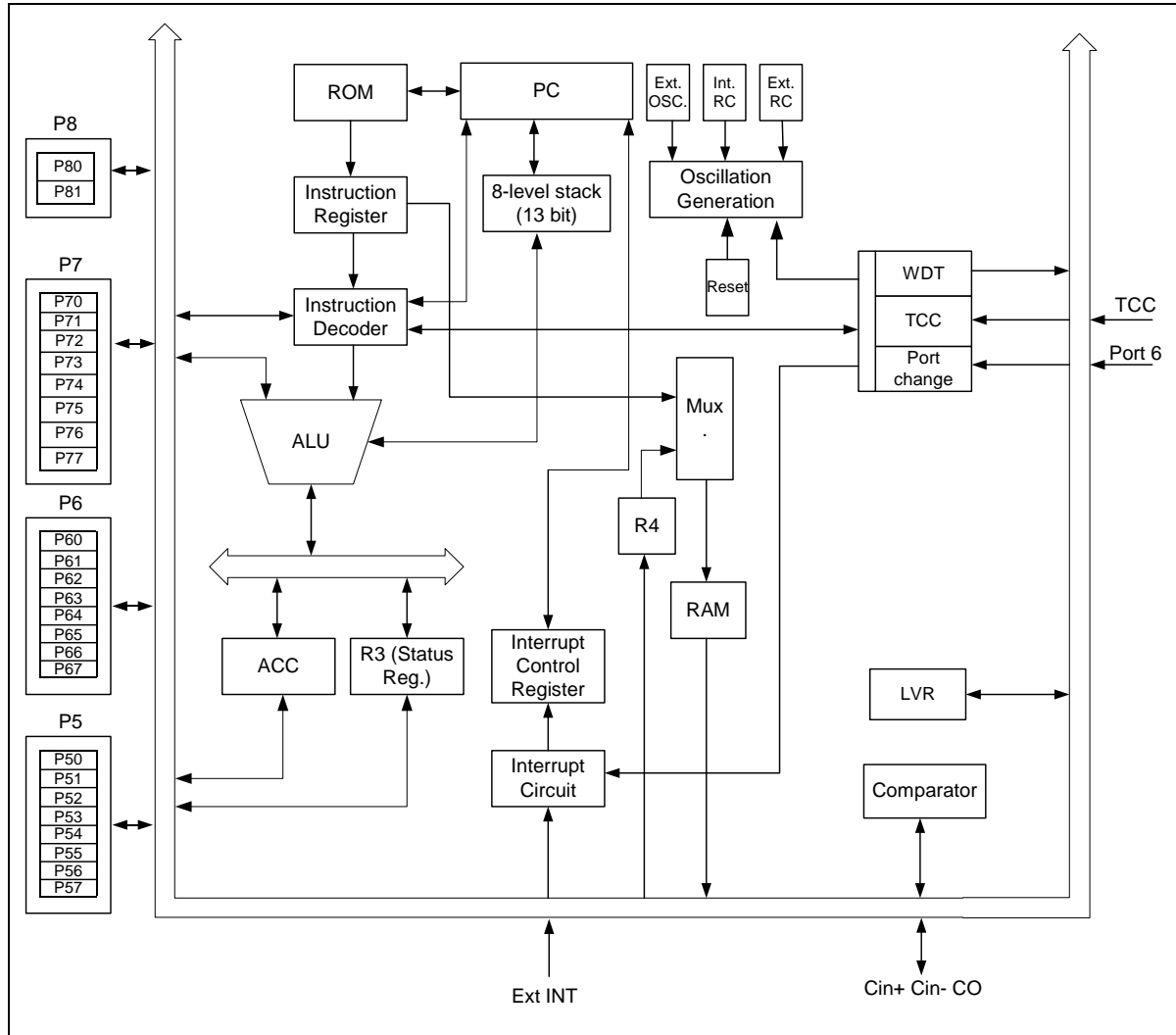

Fig. 5-1 EM78P221/2N Functional Block Diagram

6 Function Description

6.1 Register Configuration

Address	Bank 0 Registers	Bank 1 Registers	Bank 2 Registers	Bank 3 Registers
00	R0 (Indirect Addressing Register)			
01	R1 (Memory switch register)			
02	R2 (Program Counter)			
03	R3 (Status Register)			
04	R4 (Select Indirect Address)			
05	R5 (Port 5)	R5 (I/O Port Control Register)	R5 (High Drive Control Register for Port 6)	R5 (Timer Clock / Counter)
06	R6 (Port 6)	R6 (I/O Port Control Register)	R6 (High Sink Control Register for Port 5)	Reserve*
07	R7 (Port 7)	R7 (I/O Port Control Register)	R7 (High Sink Control Register for Port 6)	Reserve*
08	R8 (Port 8)	R8 (I/O Port Control Register)	Reserve	Reserve
09	Reserve	Reserve	Reserve	Reserve
0A	Reserve	RA (Comparator Control Register)	Reserve	Reserve
0B	Reserve	RB (Pull-down Control Register)	Reserve	Reserve
0C	Reserve	RC (Open-drain Control Register)	Reserve	Reserve
0D	Reserve	RD (Pull-high Control Register)	Reserve	Reserve
0E	RE (Wake-up Control Register)	RE (WDT Control Register)	Reserve	Reserve
0F	RF (Interrupt Status Register)	RF (Interrupt Mask Register)	Reserve	Reserve
10 : 1F	General Registers (16×8 bits)			
20 : 3F	General Registers (32×8 bits)	General Registers (32×8 bits)	General Registers (32×8 bits)	General Registers (32×8 bits)

Note: 1. All registers are 8 bits.

2. When using ICE, some registers code options are set. Refer to Section 6.2 for detailed Registers Description.

3. Registers with * can only be used in ICE220N simulator.

6.2 Registers Description

6.2.1 A (Accumulator)

Internal data transfer operation, or instruction operand holding usually involves the temporary storage function of the Accumulator. The Accumulator is not an addressable register.

6.2.2 CONT (Control Register)

Bit 7	Bit 6	Bit 5	Bit 4	Bit 3	Bit 2	Bit 1	Bit 0
INTE	INT	TS	TE	PSTE	PST2	PST1	PST0

Bit 7 (INTE): INT signal edge

- 0 = interrupt occurs at the rising edge on the INT0 and INT1 pin
- 1 = interrupt occurs at the falling edge on the INT0 and INT1 pin

Bit 6 (INT): Interrupt enable flag

- 0 = masked by DISI or hardware interrupt
- 1 = enabled by the ENI/RETI instructions

This bit is readable only.

Bit 5 (TS): TCC signal source

- 0 = internal instruction cycle clock. If P56 is used as I/O pin, TS must be 0.
- 1 = transition on the TCC pin

Bit 4 (TE): TCC signal edge

- 0 = increment if the transition from low to high takes place on the TCC pin
- 1 = increment if the transition from high to low takes place on the TCC pin.

Bit 3 (PSTE): Prescaler enable bit for TCC

- 0 = prescaler disable bit. TCC rate is 1:1
- 1 = prescaler enable bit. TCC rate is set as Bit 2 ~ Bit 0.

Bit 2 ~ Bit 0 (PST2 ~ PST0): TCC prescaler bits

PST2	PST1	PST0	TCC Rate
0	0	0	1:2
0	0	1	1:4
0	1	0	1:8
0	1	1	1:16
1	0	0	1:32
1	0	1	1:64
1	1	0	1:128
1	1	1	1:256

Note: Tcc time-out period $[1/Fosc \times \text{prescaler} \times (256 - \text{Tcc cnt}) \times 1]$

Fosc: Oscillator (Crystal, ERC, IRC) frequency

6.2.3 R0 (Indirect Addressing Register)

R0 is not a physically implemented register. Its major function is to perform as an indirect address pointer. Any instruction using R0 as a pointer, actually accesses the data pointed by the RAM Select Register (R4).

6.2.4 R1 (Memory Switch Register)

Bit 7	Bit 6	Bit 5	Bit 4	Bit 3	Bit 2	Bit 1	Bit 0
"0"	"0"	"0"	"0"	"0"	"0"	BS1	BS0

Bits 7~2: not used bits, fixed to 0 all the time.

Bits 1~0: used to select Banks 0 ~ 3 for R20~R3F and select Banks 0 ~ 3 for the control register.

See the table under Section 6.2 *Registers Description* for the data memory configuration.

6.2.5 R2 (Program Counter and Stack)

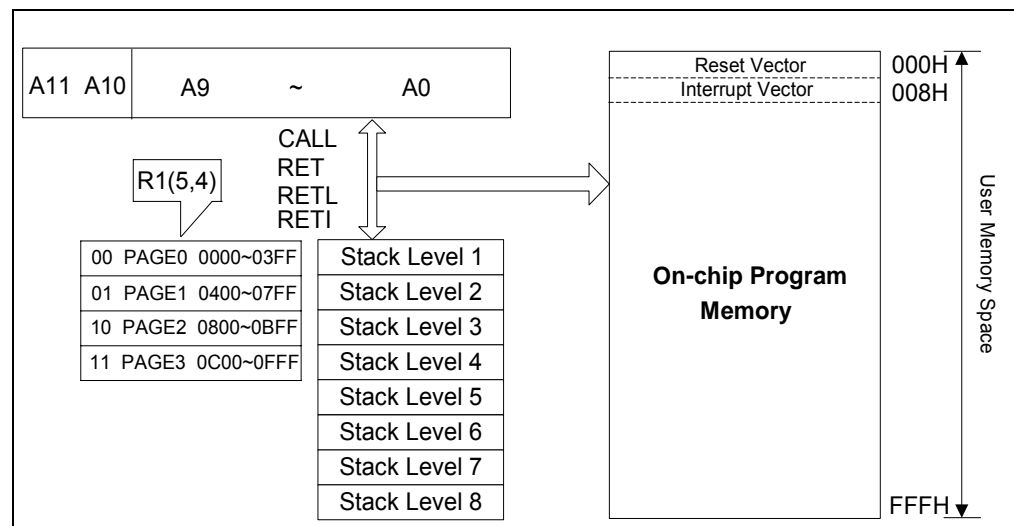

Fig. 6-1 Program Counter Organization

R2 and hardware stacks are 12-bit wide. The structure is depicted in the table under Section 6.1 *Register Configuration*.

Generates 4K×13 bits on-chip ROM addresses to the relative programming instruction codes. One program page is 1024 words long.

The contents of R2 are all set to "0"s when a reset condition occurs.



"JMP" instruction allows direct loading of the lower 10 program counter bits. Thus, "JMP" allows PC to jump to any location within a Page (1K).

"CALL" instruction loads the lower 10 bits of the PC, and then PC+1 is pushed into the stack. Thus, the subroutine entry address can be located anywhere within a page (1K).

"LJMP" instruction allows direct loading of the lower 11 program counter bits. Therefore, "LJMP" allows PC to jump to any location within 2K (2^{12}).

"LCALL" instruction loads the lower 11 bits of the PC, and then PC+1 are pushed onto the stack. Thus, the subroutine entry address can be located anywhere within 2K (2^{12}).

"RET" ("RETL k", "RETI") instruction loads the program counter with the contents of the top of stack.

"ADD R2, A" allows a relative address to be added to the current PC, and the ninth and above bits of the PC will increase progressively.

"MOV R2, A" allows loading of an address from the "A" register to the lower 8 bits of the PC, and the ninth and above bits of the PC will remain unchanged.

Any instruction (except "ADD R2,A") that is written to R2 (e.g., "MOV R2, A", "BC R2, 6" etc.) will cause the ninth bit and above bits of the PC to remain unchanged.

All instructions are single instruction cycle (fclk/2) except "LCALL" and "LJMP" instructions. The "LCALL" and "LJMP" instructions need two instructions cycle.

6.2.6 R3 (Status Register)

Bit 7	Bit 6	Bit 5	Bit 4	Bit 3	Bit 2	Bit 1	Bit 0
-	-	-	T	P	Z	DC	C

Bits 7~5: not used, fixed to 0 all the time.

Bit 4 (T): Time-out bit. Set to 1 by the "SLEP" and "WDTC" commands or during power on and reset to 0 by WDT time-out.

Bit 3 (P): Power-down bit. Set to 1 during power on or by a "WDTC" command and reset to 0 by a "SLEP" command.

NOTE
Bit 4 & Bit 3 (T & P) are read only.

Bit 2 (Z): Zero flag. Set to "1" if the result of an arithmetic or logic operation is zero.

Bit 1 (DC): Auxiliary carry flag

Bit 0 (C): Carry flag

6.2.7 R4 (Select Indirect Address)

Bits 7~6: not used, fixed to 0 all the time.

Bit 5 ~ Bit 0: used to select registers (Address: 00 ~ 3F) in indirect addressing mode.

6.2.8 Bank 0-R5 (Port 5)

Bit 7	Bit 6	Bit 5	Bit 4	Bit 3	Bit 2	Bit 1	Bit 0
P57	P56	P55	P54	P53	P52	P51	P50

Bits 7 ~ 0 (P57 ~ P50): I/O data bits

6.2.9 Bank 0-R6 (Port 6)

Bit 7	Bit 6	Bit 5	Bit 4	Bit 3	Bit 2	Bit 1	Bit 0
P67	P66	P65	P64	P63	P62	P61	P60

Bits 7 ~ 0 (P67 ~ P60): I/O data bits

6.2.10 Bank 0-R7 (Port 7)

Bit 7	Bit 6	Bit 5	Bit 4	Bit 3	Bit 2	Bit 1	Bit 0
P77	P76	P75	P74	P73	P72	P71	P70

Bits 7 ~ 0 (P77 ~ P70): I/O data bits

[With Simulator]: P73 ~ P72 are input or open-drain output pins.

[With EM78P221/2N]: P73 ~ P72 are general input or output pins.

6.2.11 Bank 0-R8 (Port 8)

Bit 7	Bit 6	Bit 5	Bit 4	Bit 3	Bit 2	Bit 1	Bit 0
0	0	NREN	0	0	0	P81	P80

Bits 7~6, 4~2, 0: not used, fixed to 0 all the time.

Bit 5 (NREN): Noise rejection enable

0 = disable noise rejection (Default)

1 = enable noise rejection. However in crystal oscillator mode (LXT2), the noise rejection circuit is always disabled.

Bits 1 ~0 (P81~P80): I/O data bit.

6.2.12 Bank 0-R9~RD (Reserve)

Bits 7~0: not used, fixed to "0" all the time.

6.2.13 Bank 0-RE (WUCR: Wake-up Control Register)

Bit 7	Bit 6	Bit 5	Bit 4	Bit 3	Bit 2	Bit 1	Bit 0
EX1IF	0	0	ICWE	0	CMPWE	0	CMPIF

Bit 7 (EX1IF): External interrupt flag. Set by INT1 pin, reset by software.

- 0 = no interrupt occurs
- 1 = with interrupt request

Bits 6~5, 3, 1: not used bits, fixed to 0 all the time

Bit 4 (ICWE): Port 6 input change to wake-up status enable bit

- 0 = Disable Port 6 input change to wake-up status
- 1 = Enable Port 6 input change wake-up status

When the Port 6 Input Status Change is used to enter interrupt vector or to wake-up EM78P221N//2N from sleep, the ICWE bit must be set to "Enable".

Bit 2 (CMPWE): Comparator wake-up enable bit

- 0 = Disable Comparator wake-up
- 1 = Enable Comparator wake-up

When the Comparator output status change is used to enter interrupt vector or to wake-up from sleep, the CMPWE bit must be set to "Enable".

Bit 0 (CMPIF): Comparator interrupt flag. Set when a change occurs in the output of Comparator. Reset by software.

- 0 = no interrupt occurs
- 1 = with interrupt request

NOTE

- Bank 0-RE <7, 0> can be cleared by instruction but cannot be set.
- Bank1-RE <0> is an interrupt mask register.
- Interrupt results from "logic AND" of Bank 0-RE <7, 0> and Bank 1-RE <0>, with instruction "ENI".

6.2.14 Bank 0-RF (Interrupt Status Register)

Bit 7	Bit 6	Bit 5	Bit 4	Bit 3	Bit 2	Bit 1	Bit 0
0	0	0	0	0	EX0IF	ICIF	TCIF

Bits 7~3: not used bits, fixed to 0 all the time

Bit 2 (EX0IF): External interrupt flag. Set by INT0 pin. Reset by software.

- 0 = no interrupt occurs
- 1 = with interrupt request

Bit 1 (ICIF): Port 6 input status change interrupt flag. Set when Port 6 input changes. Reset by software.

- 0 = no interrupt occurs
- 1 = with interrupt request

Bit 0 (TCIF): TCC overflow interrupt flag. Set when TCC overflows. Reset by software.

- 0 = no interrupt occurs
- 1 = with interrupt request

NOTE

- Bank 0-RF <2, 1, 0> can be cleared by instruction but cannot be set.
- Bank1-RF <2, 1, 0> is an interrupt mask register.
- Interrupt results from "logic AND" of Bank 0-RF <2, 1, 0> and Bank 1-RF <2, 1, 0> with instruction "ENI".

6.2.15 Bank 1-R5 ~R7 (I/O Port Control Register)

Bits 7~0: 0 = defines the relative I/O pin as output
1 = puts the relative I/O pin into high impedance

Bank 1-R5, R6 and R7 registers are all readable and writable.

6.2.16 Bank 1-R8 (I/O Port Control Register)

Bit 7	Bit 6	Bit 5	Bit 4	Bit 3	Bit 2	Bit 1	Bit 0
0	0	0	0	0	0	C81	C80

Bits 7~2: not used, fixed to 0 all the time

Bits 1~0 (C81~C80): 0 = defines the relative I/O pin as output
1 = puts the relative I/O pin into high impedance

With Simulator]: P80 and P81 are General I/O pins

[With EM78P221/2N]: P80 is General input or output, but P81 is input or open-drain output pin.

6.2.17 Bank 1-R9 (Reserve)

Bits 7~0: not used, fixed to 0 all the time

6.2.18 Bank 1-RA (CMPCON: Comparator Control Register)

Bit 7	Bit 6	Bit 5	Bit 4	Bit 3	Bit 2	Bit 1	Bit 0
EIS1	EIS0	CMPOUT	CMPCOS1	CMPCOS0	0	0	0

Bit 7 (EIS1): Control bit used to define the function of the P71 (/INT1) pin
0 = P71, normal I/O pin
1 = /INT1, external interrupt pin. In this case, the I/O control bit of P71 (Bit 1 of Bank 1-R7) must be set to "1"

Bit 6 (EIS0): Control bit used to define the function of the P77 (/INT0) pin
0 = P77, normal I/O pin
1 = /INT0, external interrupt pin. In this case, the I/O control bit of P77 (Bit 7 of Bank 1-R7) must be set to "1"

NOTE	
■	When EIS is "0," the path of /INT is masked. When EIS is "1," the status of /INT pin can also be read by way of reading Port 7 (Bank 0-R7). Refer to Fig. 6-4 (I/O Port and I/O Control Register Circuit for P77 (/INT0) and P71 (/INT1) under Section 6.4 (I/O Ports).
■	EIS0 and EIS1 are both readable and writable.
■	The highest priority of P71/INT1/CO2 is INT1. When EIS1=0, the working type of P71/INT1/CO is determined by CMPCOS1 and CMPCOS0.

Bit 5 (CMPOUT): The result of the comparator output

Bit 4 ~ Bit 3 (CMPCOS1 ~ CMPCOS0): Comparator Select bits

CMPCOS1	CMPCOS0	Function Description
0	0	Comparator is not used. P72, P73 and P71 are normal I/O pins
0	1	P72 and P73 are Comparator input pins and P71 is normal I/O pin
1	0	P72 and P73 are Comparator input pins and P71 is Comparator output pin (CO)
1	1	Used as OP and P71 is OP output pin (CO)

Bits 2~0: not used, fixed to 0 all the time

6.2.19 Bank 1-RB (Pull-down Control Register)

Bit 7	Bit 6	Bit 5	Bit 4	Bit 3	Bit 2	Bit 1	Bit 0
/PD7	/PD6	/PD5	/PD4	/PD3	/PD2	/PD1	/PD0

Bank 1-RB register is both readable and writable

Bit 7 (/PD7): Control bit used to enable the pull-down function of the P67 pin
 0 = Enable internal pull-down function
 1 = Disable internal pull-down function

Bit 6 (/PD6): Control bit used to enable the pull-down function of the P66 pin.

Bit 5 (/PD5): Control bit used to enable the pull-down function of the P65 pin.

Bit 4 (/PD4): Control bit used to enable the pull-down function of the P64 pin.

Bit 3 (/PD3): Control bit used to enable the pull-down function of the P63 pin.

Bit 2 (/PD2): Control bit used to enable the pull-down function of the P62 pin.

Bit 1 (/PD1): Control bit used to enable the pull-down function of the P61 pin.

Bit 0 (/PD0): Control bit used to enable the pull-down function of the P60 pin.

6.2.20 Bank 1-RC (Open-Drain Control Register)

Bit 7	Bit 6	Bit 5	Bit 4	Bit 3	Bit 2	Bit 1	Bit 0
/OD7	/OD6	/OD3	/OD2	/OD5	/OD4	/OD1	/OD0

Bank 1-RC register is both readable and writable.

Bit 7 (OD7): Control bit used to enable the open-drain output of the P57 pin.
 0 = Enable open-drain output
 1 = Disable open-drain output

Bit 6 (OD6): Control bit used to enable the open-drain output of the P56 pin.

Bit 5 (OD5): Control bit used to enable the open-drain output of the P55 pin.

Bit 4 (OD4): Control bit used to enable the open-drain output of the P54 pin.

Bit 3 (OD3): Control bit used to enable the open-drain output of the P53 pin.

Bit 2 (OD2): Control bit used to enable the open-drain output of the P52 pin.

Bit 1 (OD1): Control bit used to enable the open-drain output of the P51 pin.

Bit 0 (OD0): Control bit used to enable the open-drain output of the P50 pin.

6.2.21 Bank 1-RD (Pull-high Control Register)

Bit 7	Bit 6	Bit 5	Bit 4	Bit 3	Bit 2	Bit 1	Bit 0
/PH7	/PH6	/PH5	/PH4	/PH3	/PH2	/PH1	/PH0

Bank 1-RD register is both readable and writable.

Bit 7 (/PH7): Control bit used to enable the pull-high function of the P67 pin.

0 = Enable internal pull-high

1 = Disable internal pull-high

Bit 6 (/PH6): Control bit used to enable the pull-high function of the P66 pin.

Bit 5 (/PH5): Control bit used to enable the pull-high function of the P65 pin.

Bit 4 (/PH4): Control bit used to enable the pull-high function of the P64 pin.

Bit 3 (/PH3): Control bit used to enable the pull-high function of the P53 pin.

Bit 2 (/PH2): Control bit used to enable the pull-high function of the P52 pin.

Bit 1 (/PH1): Control bit used to enable the pull-high function of the P51 pin.

Bit 0 (/PH0): Control bit used to enable the pull-high function of the P50 pin.

6.2.22 Bank 1-RE (WDT Control Register)

Bit 7	Bit 6	Bit 5	Bit 4	Bit 3	Bit 2	Bit 1	Bit 0
WDTE	0	PSWE	PSW2	PSW1	PSW0	0	CMPIE

NOTE

- Bank 1-RE <0> register is both readable and writable
- Individual interrupt is enabled by setting its associated control bit in the Bank 1-RF <0 > to "1."
- Global interrupt is enabled by the ENI instruction and is disabled by the DISI instruction. Refer to Fig. 6-8 (Interrupt Input Circuit) under Section 6.6 (Interrupt).

Bit 7 (WDTE): Control bit is used to enable Watchdog Timer

0 = Disable WDT

1 = Enable WDT

WDTE is both readable and writable.

Bits 6, 1: not used, fixed to 0 all the time

Bit 5 (PSWE): Prescaler enable bit for WDT

0 = prescaler disable bit. WDT rate is 1:1

1 = prescaler enable bit. WDT rate is set as Bit 4~Bit 2

Bit 4 ~ Bit 2 (PSW2 ~ PSW0): WDT prescaler bits

PSW2	PSW1	PSW0	WDT Rate
0	0	0	1:2
0	0	1	1:4
0	1	0	1:8
0	1	1	1:16
1	0	0	1:32
1	0	1	1:64
1	1	0	1:128
1	1	1	1:256

Bit 0 (CMPIE): CMPIF interrupt enable bit

- 0** = Disable CMPIF interrupt
- 1** = Enable CMPIF interrupt

When the Comparator output status change is used to enter an interrupt vector or to enter next instruction, the CMPIE bit must be set to "Enable". But actually the output of the comparator must be read to latch the status first. Then the output of the comparator is compared to this latch to produce the information of output status change.

6.2.23 Bank 1-RF (Interrupt Mask Register)

Bit 7	Bit 6	Bit 5	Bit 4	Bit 3	Bit 2	Bit 1	Bit 0
0	0	0	0	0	EXIE	ICIE	TCIE

NOTE

- RF register is both readable and writable.
- Individual interrupt is enabled by setting its associated control bit in the RF to "1."
- Global interrupt is enabled by the ENI instruction and is disabled by the DISI instruction. Refer to Fig. 6-8 (Interrupt Input Circuit) under Section 6.6 (Interrupt).

Bits 7~3: not used bits, fixed to 0 all the time

Bit 2 (EXIE): EX0IF and EX1IF interrupts enable bit
0 = Disable EX0IF and EX1IF interrupts
1 = Enable EX0IF and EX1IF interrupts

Bit 1 (ICIE): ICIF interrupt enable bit
0 = Disable ICIF interrupt
1 = Enable ICIF interrupt
 If Port 6 Input Status Change Interrupt is used to enter an interrupt vector or to enter next instruction, the ICIE bit must be set to "Enable".

Bit 0 (TCIE): TCIF interrupt enable bit
0 = Disable TCIF interrupt
1 = Enable TCIF interrupt

6.2.24 Bank 2-R5 (HDCR: High Drive Control Register for Port 6)

Bit 7	Bit 6	Bit 5	Bit 4	Bit 3	Bit 2	Bit 1	Bit 0
HD67	HD66	HD65	HD64	HD63	HD62	HD61	HD60

[With Simulator]: function nonexistent

[With EM78P221/2N]: General I/O pins

Bit 7 (HD67): Output High Drive Current Select for P67

Bit 6 (HD66): Output High Drive Current Select for P66

Bit 5 (HD65): Output High Drive Current Select for P65

Bit 4 (HD64): Output High Drive Current Select for P64

Bit 3 (HD63): Output High Drive Current Select for P63

Bit 2 (HD62): Output High Drive Current Select for P62

Bit 1 (HD61): Output High Drive Current Select for P61

Bit 0 (HD60): Output High Drive Current Select for P60

HDxx	VDD = 5V, Drive Current
0	9mA (in 0.9VDD)
1	27mA (in 0.7VDD)

6.2.25 Bank 2-R6 (HSCR1: High Sink Control Register for Port 5)

Bit 7	Bit 6	Bit 5	Bit 4	Bit 3	Bit 2	Bit 1	Bit 0
HS57	HS56	HS55	HS54	HS53	HS52	HS51	HS50

[With Simulator]: function nonexistent

[With EM78P221/2N]: General I/O pins

Bit 7 (HS57): Output High Sink Current Select for P57

Bit 6 (HS56): Output High Sink Current Select for P56

Bit 5 (HS55): Output High Sink Current Select for P55

Bit 4 (HS54): Output High Sink Current Select for P54

Bit 3 (HS53): Output High Sink Current Select for P53

Bit 2 (HS52): Output High Sink Current Select for P52

Bit 1 (HS51): Output High Sink Current Select for P51

Bit 0 (HS50): Output High Sink Current Select for P50

HDxx	VDD = 5V, Sink Current
0	18mA (in 0.1VDD)
1	75mA (in 0.3VDD)

6.2.26 Bank 2-R7 (HSCR2: High Sink Control Register for Port 6)

Bit 7	Bit 6	Bit 5	Bit 4	Bit 3	Bit 2	Bit 1	Bit 0
HS67	HS66	HS65	HS64	HS63	HS62	HS61	HS60

[With Simulator]: function nonexistent

[With EM78P221/2N]: General I/O pins.

Bit 7 (HS67): Output High Sink Current Select for P67

Bit 6 (HS66): Output High Sink Current Select for P66

Bit 5 (HS65): Output High Sink Current Select for P65

Bit 4 (HS64): Output High Sink Current Select for P64

Bit 3 (HS63): Output High Sink Current Select for P63

Bit 2 (HS62): Output High Sink Current Select for P62

Bit 1 (HS61): Output High Sink Current Select for P61

Bit 0 (HS60): Output High Sink Current Select for P60

HDxx	VDD = 5V, Sink Current
0	18 mA (in 0.1VDD)
1	75 mA (in 0.3VDD)

6.2.27 Bank 2-R8 (Operating Mode Control Register)

Bit 7	Bit 6	Bit 5	Bit 4	Bit 3	Bit 2	Bit 1	Bit 0
0	1	1	0	0	0	0	0

Bits 7, 4~0: not used, fixed to "0" all the time.

Bits 6~5: not used, fixed to "1" all the time.

NOTE

■ If user wants the MCU to work normally, user must set Bit 6 and Bit 5 of the R8 register to "1" and clear Bit 4 of R8 register to "0".

6.2.28 Bank 2-R9~RF (Reserve)

Bits 7~0: not used, fixed to "0" all the time

6.2.29 Bank 3-R5 (Timer Clock/Counter)

- Incremented by an external signal edge through the TCC pin, or by the instruction cycle clock.
- External signal of TCC trigger pulse width must be greater than one instruction.
- The signals to increase the counter are determined by Bit 4 and Bit 5 of the CONT register.
- Writable and readable as any other registers.

6.2.30 Bank 3-R6 (IRC Control)-only for ICE

Bit	7	6	5	4	3	2	1	0
EM78P221/2N	'0'	'0'	'0'	'0'	'0'	'0'	'0'	'0'
ICE220N	C3	C2	C1	C0	RCM1	RCM0	'0'	'0'

Bits 7 ~ 2:

[With Simulator (C3~C0, RCM1~RCM0)]: IRC calibration bits in IRC oscillator mode.

In IRC oscillator mode of ICE220N simulator, these are the IRC mode selection bits and IRC calibration bits.

[With EM78P221/2N]: Unimplemented, read as '0'.

Bits 7 ~ 4 (C3 ~ C0): Calibrator of internal RC mode

C3	C2	C1	C0	Frequency (MHz)
0	0	0	0	$(1-36%) \times F$
0	0	0	1	$(1-31.5%) \times F$
0	0	1	0	$(1-27%) \times F$
0	0	1	1	$(1-22.5%) \times F$
0	1	0	0	$(1-18%) \times F$
0	1	0	1	$(1-13.5%) \times F$
0	1	1	0	$(1-9%) \times F$
0	1	1	1	$(1-4.5%) \times F$
1	1	1	1	F (default)
1	1	1	0	$(1+4.5%) \times F$
1	1	0	1	$(1+9%) \times F$
1	1	0	0	$(1+13.5%) \times F$
1	0	1	1	$(1+18%) \times F$
1	0	1	0	$(1+22.5%) \times F$
1	0	0	1	$(1+27%) \times F$
1	0	0	0	$(1+31.5%) \times F$

1. Frequency values shown are theoretical and taken at an instance of a high frequency mode. Hence, frequency values are shown for reference only. Definite values depend on the actual process.
2. Similar way of calculation is also applicable to low frequency mode.

Bits 3 ~ 2 (RCM1 ~ RCM0): IRC mode selection bits

RCM 1	RCM 0	Frequency (MHz)
1	1	4 (default)
1	0	16
0	1	1
0	0	455kHz

Bits 1 ~ 0: are not used, fixed to "0" all the time.

6.2.31 Bank 3-R7 (Noise and LVR Control) - only for ICE

Bit	7	6	5	4	3	2	1	0
EM78P221/2N	'0'	'0'	'0'	'0'	'0'	'0'	'0'	'0'
ICE220N	"0"	"0"	"0"	"0"	NRHL	NRE	LVR1	LVR0

Bits 7 ~ 4: not used, fixed to "0" all the time.

Bits 3 ~ 0:

[With EM78P221/2N]: Unimplemented, read as '0'.

[With Simulator]:

Bit 3 (NRHL): Noise rejection high/low pulses define bit. The INT pin is a falling edge trigger

0 = Pulses equal to $8/f_c$ [s] are regarded as signal.

1 = Pulses equal to $32/f_c$ [s] are regarded as signal (default)

NOTE

The noise rejection function is turned off in the LXT2 and sleep mode.

Bit 2 (NRE): Noise rejection enable

0 = disable noise rejection

1 = enable noise rejection (default). However in Low Crystal oscillator (LXT) mode, the noise rejection circuit is always disabled.

Bits 1 ~ 0 (LVR1 ~ LVR0): Low Voltage Reset enable bits. If V_{dd} has crossover at V_{dd} reset level as V_{dd} changes, the system will be reset.

LVR1, LVR0	VDD Reset Level	VDD Release Level
11	NA (Power-on Reset) (default)	
10	2.5V	2.7V
01	3.0V	3.2V
00	4.0V	4.2V

6.2.32 Bank 3-R8~RF (Reserve)

Bits 7~0: not used, fixed to "0" all the time.

6.2.33 R10 ~ R1F

All of these are 8-bit general-purpose registers.

6.2.34 Banks 0~3 - R20 ~ R3F

All of these are 8-bit general-purpose registers.

6.3 TCC/WDT and Prescaler

There are two 8-bit counters available as prescalers for the TCC and WDT. The PST0~PST2 bits of the CONT register are used to determine the ratio of the TCC prescaler, and the PWR0~PWR2 bits of the Bank 1-RE register are used to determine the WDT prescaler. The prescaler counter is cleared by the instructions each time such instructions are written into TCC. The WDT and prescaler are cleared by the "WDTC" and "SLEP" instructions. Fig. 6-2 depicts the block diagram of TCC/WDT.

TCC (Bank 3-R5) is an 8-bit timer/counter. The TCC clock source can be internal clock (Fosc) or external signal input (edge selectable from the TCC pin). If the TCC signal source is from an external clock input, TCC will be incremented by 1 at every falling edge or rising edge of the TCC pin. The TCC pin input time length (kept at High or Low level) must be greater than 1CLK. 1 CLK is always $F_{osc}/2$. Refer to Fig. 6-2.

NOTE

The internal TCC will stop running when in sleep mode.

The watchdog timer is a free running on-chip RC oscillator. The WDT will keep on running even when the oscillator driver has been turned off (i.e., in sleep mode). During normal operation or sleep mode, a WDT time-out (if enabled) will cause the device to reset. The WDT can be enabled or disabled at any time during normal mode through software programming. Refer to WDTE bit of Bank 1-RE register (Section 6.2.10 Bank 1-RE (WDT Control Register)). With no prescaler, the WDT time-out duration is approximately 18ms.¹

¹ VDD=5V, WDT Time-out period = 15.2ms \pm 30%.
VDD=3V, WDT Time-out period = 18ms \pm 30%.

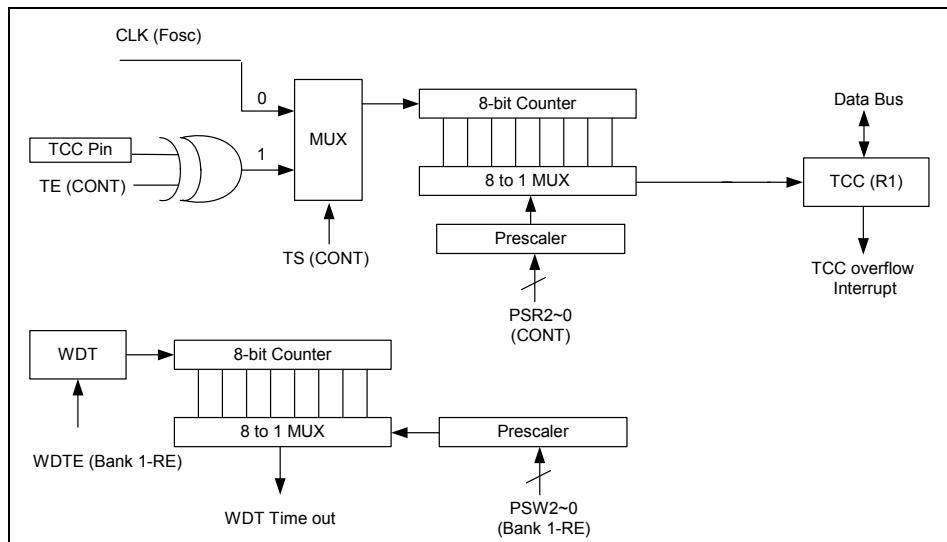
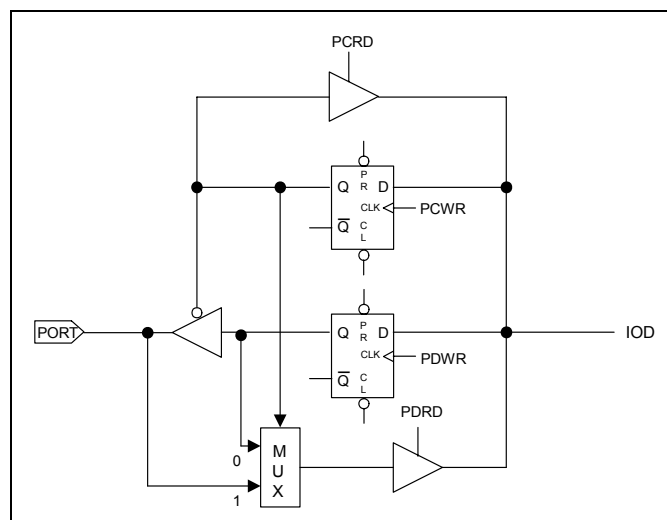

Fig. 6-2 TCC and WDT Block Diagram

6.4 I/O Ports

The I/O registers (Port 5, Port 6, Port 7, and Port 8) are bidirectional tri-state I/O ports. The Pull-high, Pull-down, and Open-drain functions can be set internally by Bank 1-RB, Bank 1-RC, and Bank 1-RD respectively. The High Drive, and High Sink functions can be set internally by Bank 2-R5, Bank 2-R6, and Bank 2-R7 respectively. Port 6 features an input status change interrupt (or wake-up) function. Most I/O pin can be defined as "input" or "output" pin by the I/O control registers (P52, P53 are only used as output pins). The I/O registers and I/O control registers are both readable and writable. However, the initial states of these I/O ports (Port 5, Port 6, Port 7 and Port 8) are unknown input (high impedance). Then, if the I/O pin is pulled to a level at external circuit, the pin must induce a voltage. Hence, user must take into consideration whether the induced voltage causes a wrong action in the system. The I/O interface circuits for Port 5, Port 6, Port 7, and Port 8 are illustrated in Figures 6-3, 6-4, & 6-5 respectively. Port 6 with Input Change Interrupt/Wake-up is shown in Fig. 6-6.



Note: Pull-high and Open-drain are not shown in the figure.

Fig. 6-3 I/O Port and I/O Control Register Circuit for Port 5, Port 7 and Port 8

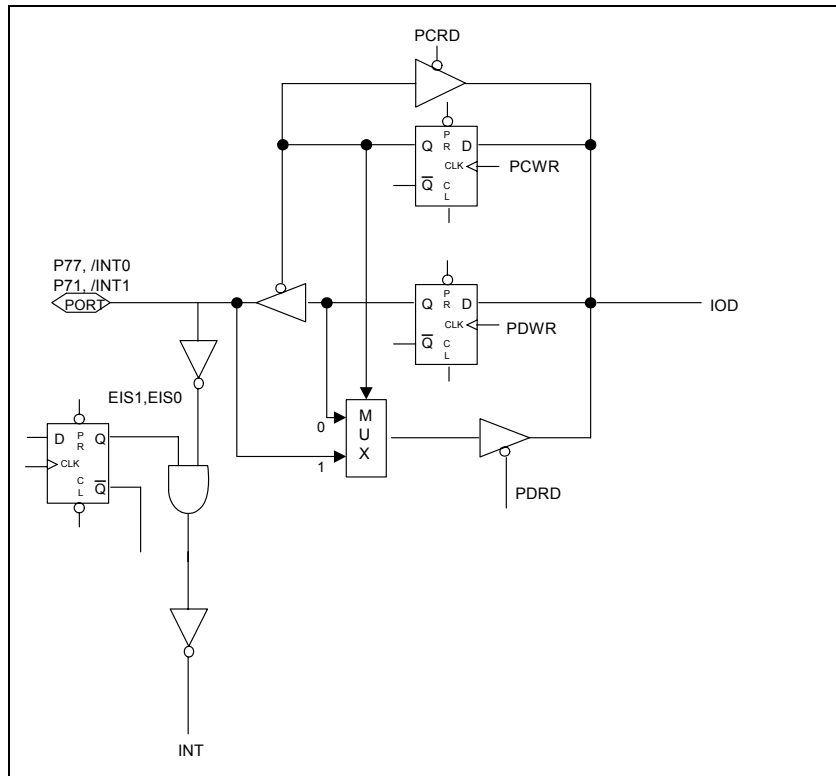

Note: CO2, Pull-high and Open-drain are not shown in the figure.

Fig. 6-4 I/O Port and I/O Control Register Circuit for P77 (/INT0) and P71 (/INT1)

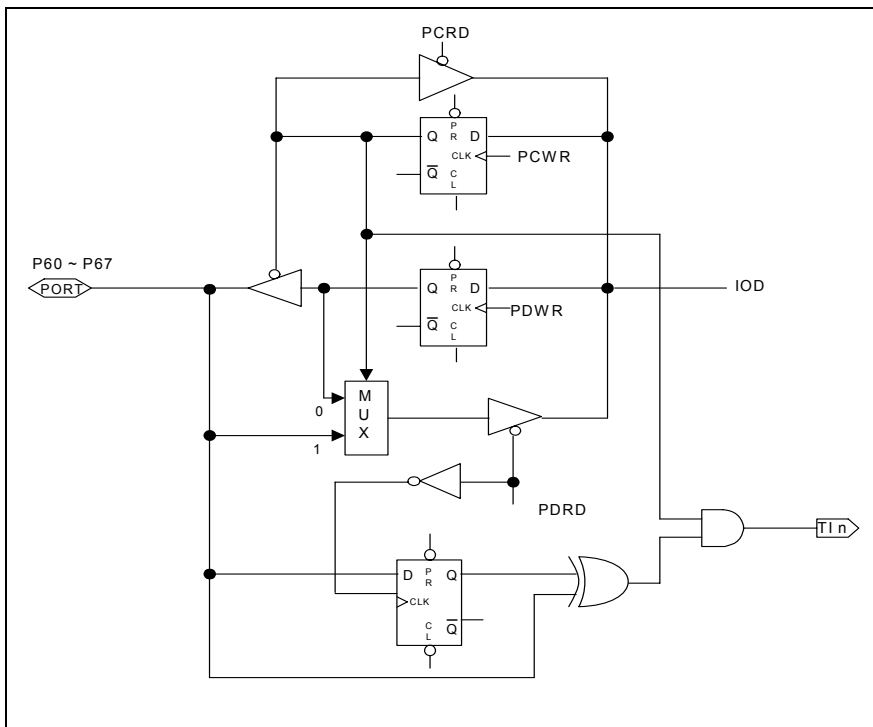

Note: Pull-high (down) and Open-drain are not shown in the figure.

Fig. 6-5 I/O Port and I/O Control Register Circuit for Port 6

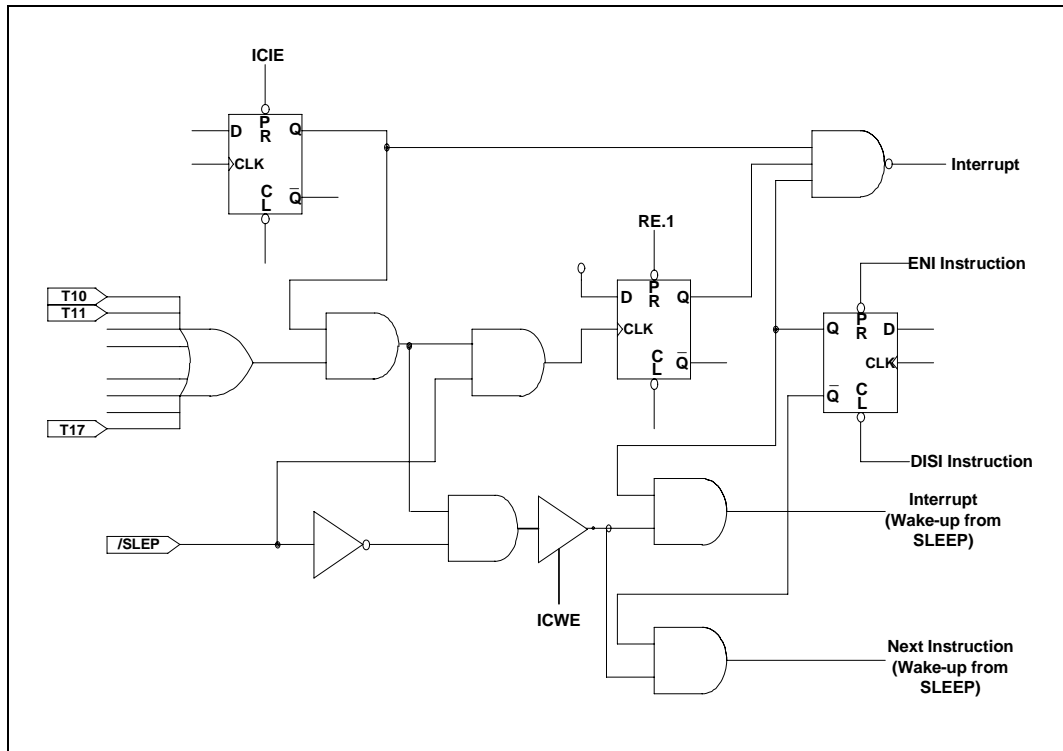

Fig. 6-6 Port 6 Block Diagram with Input Change Interrupt/Wake-up

6.4.1 Usage of Port 6 Input Change Wake-up/Interrupt Function

Usage of Port 6 Input Status Change Wake-up/Interrupt	
(1) Wake-up	(2) Wake-up and Interrupt
(a) Before Sleep	(a) Before Sleep
1. Disable WDT	1. Disable WDT
2. Read I/O Port 6 (MOV R6,R6)	2. Read I/O Port 6 (MOV R6,R6)
3. Execute "ENI" or "DISI"	3. Execute "ENI" or "DISI"
4. Enable wake-up bit (Set Bank 0-RE ICWE =1)	4. Enable wake-up bit (Set Bank 0-RE ICWE =1)
5. Execute "SLEP" instruction	5. Enable interrupt (Set BANK1-RF ICIE =1)
(b) After wake-up	6. Execute "SLEP" instruction
→ Next instruction	(b) After wake-up
	1. IF "ENI" → Interrupt vector (008H)
	2. IF "DISI" → Next instruction
(3) Interrupt	
(a) Before Port 6 pin change	
1. Read I/O Port 6 (MOV R6,R6)	
2. Execute "ENI" or "DISI"	
3. Enable interrupt (Set BANK1-RF ICIE =1)	
(b) After Port 6 pin changed (interrupt)	
1. IF "ENI" → Interrupt vector (008H)	
2. IF "DISI" → Next instruction	

6.5 Reset and Wake-up

6.5.1 Reset and Wake-up Operation

A reset is initiated by one of the following events:

1. Power-on reset
2. /RESET pin input "low"
3. WDT time-out (if enabled)

A device is kept in a reset condition for a duration of approximately 18ms² after the reset is detected. When in LXT mode, the reset time is 500ms. Once a reset occurs, the following functions are performed (the initial address is 000h):

- The oscillator continues running, or will be started (if in sleep mode)
- The Program Counter (R2) is set to all "0"
- All I/O port pins are configured as input mode (high-impedance state)
- The Watchdog Timer and prescaler are cleared
- When power is switched On, the Memory switch register (R1) is set to 0
- The CONT register bits are set to all "0" except for Bit 6 (INT flag)
- The Bank 0-RF register bits are set to all "0"
- The Bank 1-RB register bits are set to all "1"
- The Bank 1-RC register bits are set to all "1"
- The Bank 1-RD register bits are set to all "1"
- The Bank 1-RE register bits are set to all "0"
- The Bank 1-RF register bits are set to all "0"

Executing the "SLEP" instruction will assert the sleep (power down) mode. While entering sleep mode, the Oscillator and TCC are stopped. The WDT (if enabled) is cleared but keeps on running.

The controller can be awakened by:

- Case 1 External reset input on /RESET pin
- Case 2 WDT time-out (if enabled)
- Case 3 Port 6 input status changes (if ICWE is enabled)
- Case 4 Comparator output status changes (if CMPWE is enabled)

² VDD=5V, Setup time period = 16.5ms ± 30%.
VDD=3V, Setup time period = 18ms ± 30%.

The first two cases (1 & 2) will cause the EM78P221/2N to reset. The T and P flags of R3 can be used to determine the source of the reset (wake-up). Cases 3 & 4 are considered the continuation of program execution and the global interrupt ("ENI" or "DISI" being executed) decides whether or not the controller branches to the interrupt vector following a wake-up. If ENI is executed before SLEP, the instruction will begin to execute from Address 0x8 after wake-up. If DISI is executed before SLEP, the execution will restart from the instruction next to SLEP after wake-up. All sleep mode wake up time is dependent on the oscillator mode, no matter what the oscillator type or mode is (except when it's in LXT2 mode). In LXT2 mode, wake-up time is 2 ~ 3 sec.

Only one of Cases 1 to 4 can be enabled before entering into sleep mode. That is:

Case [a] If WDT is enabled before SLEP, all of the RE bit is disabled. Hence, the EM78P221/2N can be awakened only with Case 1 or Case 2. Refer to the section on Interrupt (Section 6.6) for further details.

Case [b] If Port 6 Input Status Change is used to wake -up EM78P221/2N and ICWE bit of Bank 0-RE register is enabled before SLEP, WDT must be disabled. Hence, the EM78P221/2N can be awakened only with Case 3. Wake-up time is dependent on the oscillator mode. In RC mode (VDD: 5V, IRC: 4MHz), wake-up time is 10 μ s (for stable oscillators). In HXT2 mode (VDD: 5V, Crystal: 4MHz, C1/C2: 30pF), wake-up time is 800 μ s (for stable oscillators), and in LXT2 mode, wake-up time is 2 ~ 3 sec.

Case [c] If the Comparator output status change is used to wake-up the EM78P221/ 2N and the CMPWE bit of the RE register is enabled before SLEP, WDT must be disabled by software. Hence, the EM78P221/2N can be awakened only with Case 4.

Wake-up time is dependent on the oscillator mode. In RC mode (VDD: 5V, IRC: 4MHz), wake-up time is 10 μ s (for stable oscillators). In HXT2 mode (VDD: 5V, Crystal: 4MHz, C1/C2: 30 pF), wake-up time is 800 μ s (for stable oscillators), and in LXT2 mode, wake-up time is 2 ~ 3 sec.



If Port 6 Input Status Change Interrupt is used to wake up the EM78P221/2N (as in Case b above), the following instructions must be executed before SLEEP:

```

MOV      A, @000110xxb    ; Select WDT prescaler and disable WDT
BANK     1
MOV      RE, A
WDTC                                ; Clear WDT and prescaler
BANK     0
MOV      R6, R6           ; Read Port 6
ENI (or DISI)           ; Enable (or disable) global interrupt
MOV      A, @xxx1xxxxb   ; Enable Port 6 input change wake-up bit
MOV      RE
MOV      A, @00000x1xb   ; Enable Port 6 input change interrupt
BANK     1
MOV      RF, A
SLEEP                                ; Sleep
    
```

Similarly, if the Comparator Interrupt is used to wake up the EM78P221/2N (as in Case [c] above), the following instructions must be executed before SLEEP:

```

MOV      A, @xxx01xxxb   ; Select Comparator and P71 functions as
                        ; general I/O pin
BANK     1
MOV      RA, A
MOV      A, @000110xxb   ; Select WDT prescaler and Disable WDT
MOV      RE, A
WDTC                                ; Clear WDT and prescaler
ENI (or DISI)           ; Enable (or disable) global interrupt
MOV      A, @00000100b   ; Enable comparator output status change
                        ; wake-up bit
BANK     0
MOV      RE, A
BANK     1
MOV      A, @0x00000001b ; Enable Comparator 1 output status change
                        ; interrupt
MOV      RE, A
SLEEP                                ; Sleep
    
```

6.5.1.1 Wake-up and Interrupt Modes Operation Summary

All categories under Reset, Wake-up and Interrupt modes are summarized below.

Wake-up Signal	Sleep Mode	Normal Mode
External interrupt	x	Interrupt (if interrupt enable) or next instruction
Port 6 pin change	If enable ICWE bit Wake-up + interrupt (if interrupt enable)+ next instruction	Interrupt (if interrupt enable) or next instruction
TCC overflow interrupt	x	Interrupt (if interrupt enable) or next instruction
Comparator interrupt	If enable CMPWE bit Wake-up + interrupt (if interrupt enable) + next instruction	Interrupt (if interrupt enable) or next instruction
WDT Time out	Reset to Normal mode	Reset to Normal mode
Low Voltage Reset	Reset to Normal mode	Reset to Normal mode

After wake up:

1. If interrupt enable → interrupt+ next instruction
2. If interrupt disable → next instruction



The controller can be awakened from sleep mode and idle mode. The wake-up signals are listed as follows:

Signal	Sleep Mode	Normal Mode
INT0 INT1	N/A	DISI + Bank 1-RF (EXIE) Bit 2 = 1 Next Instruction+ Set Bank 0-RF (EX0IF) = 1 or Set Bank 0-RE (EX1IF) = 1 ENI + Bank 1-RF (EXIE) Bit 2 = 1 Interrupt Vector (0x08)+ Set Bank 0-RF (EX0IF) = 1
Port 6 Input Status Change	Bank 0-RE (ICWE) Bit 4 = 0, Bank 1-RF (ICIE) Bit 1 = 0 Oscillator, TCC and TCC are stopped. Port 6 input status changed wake-up is invalid.	Bank 1-RF (ICIE) Bit 1 = 0 Port 6 input status change interrupt is invalid
	Bank 0-RE (ICWE) Bit 4 = 0, Bank 1-RF (ICIE) Bit 1 = 1 Set Bank 0-RF (ICIF) = 1, Oscillator and TCC are stopped. Port 6 input status changed wake-up is invalid.	N/A
	Bank 0-RE (ICWE) Bit 4 = 1, Bank 1-RF (ICIE) Bit 1 = 0 Wake-up+ Next Instruction Oscillator and TCC are stopped.	N/A
	Bank 0-RE (ICWE) Bit 4 = 1, DISI + Bank 1-RF (ICIE) Bit 1 = 1 Wake-up+ Next Instruction+ Set Bank 0-RF (ICIF) = 1 Oscillator and TCC are stopped.	DISI + Bank 1-RF (ICIE) Bit 1 = 1 Next Instruction+ Set Bank 0-RF (ICIF) = 1
	Bank 0-RE (ICWE) Bit 4 = 1, ENI + Bank 1-RF (ICIE) Bit 1 = 1 Wake-up+ Interrupt Vector (0x08)+ Set Bank 0-RF (ICIF) = 1 Oscillator, TCC and TIMERX are stopped.	ENI + Bank 1-RF (ICIE) Bit 1 = 1 Interrupt Vector (0x08)+ Set Bank 0-RF (ICIF) = 1
	DISI + Bank 1-RF (TCIE) Bit 0 = 1 Next Instruction+ Set Bank 0-RF (TCIF) = 1 ENI + Bank 1-RF (TCIE) Bit 0=1 Interrupt Vector (0x08)+ Set Bank 0-RF (TCIF) = 1	
	Bank 0-RE (CMPWE) Bit 2 = 0 Bank 1-RE (CMPIE) Bit 0 = 0 Comparator output status changed wake-up is invalid. Oscillator and TCC are stopped.	Bank 1-RE (CMPIE) Bit 0 = 0 Comparator output status change interrupt is invalid.
Bank 0-RE (CMPWE) Bit 2 = 0, } Bank 1-RE (CMPIE) Bit 0 = 1 Set Bank 0-RE (CMPIF) = 1, Comparator output status changed wake-up is invalid. Oscillator and TCC are stopped.		
Bank 0-RE (CMPWE) Bit 2 = 1, Bank 1-RE (CMPIE) Bit 0 = 0 Wake-up+ Next Instruction, Oscillator and TCC are stopped.		
Bank 0-RE (CMPWE) Bit 2 = 1, DISI + Bank 1-RE (CMPIE) Bit 0 = 1 Wake-up+ Next Instruction+ Set Bank 0-RE (CMPIF) Bit 0 = 1, Oscillator and TCC are stopped.	DISI + Bank 1-RE (CMPIE) Bit 0 = 1 Next Instruction+ Set Bank 0-RE (CMPIF) Bit 0 = 1	
Bank 0-RE (CMPWE) Bit 2 = 1, ENI + Bank 1-RE (CMPIE) Bit 0 = 1 Wake-up+ Interrupt Vector (0x08)+ Set Bank 0-RE (CMPIF) Bit 0 = 1, Oscillator and TCC are stopped.	ENI + Bank 1-RE (CMPIE) Bit 0 = 1 Interrupt Vector (0x08)+ Bank 0-RE (CMPIF) Bit 0 = 1	
WDT Time-out Bank 1-RE (WDTE) Bit 7=1	Wake-up+ Reset (Address 0x00)	Reset (Address 0x00)
Low Voltage Reset	Wake-up+ Reset (Address 0x00)	Reset (Address 0x00)

6.5.1.2 Register Initial Values after Reset

The following table summarizes the registers initialized values.

Address	Name	Reset Type	Bit 7	Bit 6	Bit 5	Bit 4	Bit 3	Bit 2	Bit 1	Bit 0
N/A	CONT	Bit Name	INTE	INT	TS	TE	PSTE	PST2	PST1	PST0
		Power-on	0	0	0	0	0	0	0	0
		/RESET & WDT	0	0	0	0	0	0	0	0
		Wake-up from Pin Change	P	P	P	P	P	P	P	P
0x00	R0 (IAR)	Bit Name	-	-	-	-	-	-	-	-
		Power-on	U	U	U	U	U	U	U	U
		/RESET & WDT	P	P	P	P	P	P	P	P
		Wake-up from Pin Change	P	P	P	P	P	P	P	P
0x01	R1 (MSR)	Bit Name	-	-	-	-	-	-	BS1	BS
		Power-on	0	0	0	0	0	0	0	0
		/RESET & WDT	0	0	0	0	0	0	0	0
		Wake-up from Pin Change	P	P	P	P	P	P	P	P
0x02	R2 (PC)	Bit Name	-	-	-	-	-	-	-	-
		Power-on	0	0	0	0	0	0	0	0
		/RESET & WDT	0	0	0	0	0	0	0	0
		Wake-up from Pin Change	Jump to Address 0x08 or continue to execute next instruction							
0x03	R3 (SR)	Bit Name	-	-	-	T	P	Z	DC	C
		Power-on	0	0	0	1	1	U	U	U
		/RESET & WDT	0	0	0	t	t	P	P	P
		Wake-up from Pin Change	P	P	P	t	t	P	P	P
0x04	R4 (RSR)	Bit Name	-	-	-	-	-	-	-	-
		Power-on	0	0	U	U	U	U	U	U
		/RESET & WDT	0	0	P	P	P	P	P	P
		Wake-up from Pin Change	P	P	P	P	P	P	P	P
0x05	Bank 0-R5	Bit Name	P57	P56	P55	P54	P53	P52	P51	P50
		Power-on	U	U	U	U	U	U	U	U
		/RESET & WDT	U	U	U	U	U	U	U	U
		Wake-up from Pin Change	P	P	P	P	P	P	P	P
0x06	Bank 0-R6	Bit Name	P67	P66	P65	P64	P63	P62	P61	P60
		Power-on	U	U	U	U	U	U	U	U
		/RESET & WDT	U	U	U	U	U	U	U	U
		Wake-up from Pin Change	P	P	P	P	P	P	P	P



Address	Name	Reset Type	Bit 7	Bit 6	Bit 5	Bit 4	Bit 3	Bit 2	Bit 1	Bit 0
0x07	Bank 0-R7	Bit Name	P77	P76	P75	P74	P73	P72	P71	P70
		Power-on	U	U	U	U	U	U	U	U
		/RESET & WDT	U	U	U	U	U	U	U	U
		Wake-up from Pin Change	P	P	P	P	P	P	P	P
0x8	Bank 0-R8	Bit Name	-	-	NREN	-	-	-	P81	P80
		Power-on	0	0	0	0	0	0	U	U
		/RESET & WDT	0	0	0	0	0	0	U	U
		Wake-up from Pin Change	P	P	P	P	P	P	P	P
0x9 ~ 0xD	Bank 0-R9~RD (Reserve)	Bit Name	-	-	-	-	-	-	-	-
		Power-on	0	0	0	0	0	0	0	0
		/RESET & WDT	0	0	0	0	0	0	0	0
		Wake-up from Pin Change	P	P	P	P	P	P	P	P
0xE	Bank 0-RE (WUCR)	Bit Name	EX11F	-	-	ICWE	-	CMPWE	-	CMPIF
		Power-on	0	0	0	0	0	0	0	0
		/RESET & WDT	0	0	0	0	0	0	0	0
		Wake-up from Pin Change	P	P	P	P	P	P	P	P
0xF	Bank 0-RF (ISR)	Bit Name	-	-	-	-	-	EX0IF	ICIF	TCIF
		Power-on	0	0	0	0	0	0	0	0
		/RESET & WDT	0	0	0	0	0	0	0	0
		Wake-up from Pin Change	P	P	P	P	P	P	P	P
0x05	Bank 1-R5	Bit Name	C57	C56	C55	C54	C53	C52	C51	C50
		Power-on	1	1	1	1	1	1	1	1
		/RESET & WDT	1	1	1	1	1	1	1	1
		Wake-up from Pin Change	P	P	P	P	P	P	P	P
0x06	Bank 1-R6	Bit Name	C67	C66	C65	C64	C63	C62	C61	C60
		Power-on	1	1	1	1	1	1	1	1
		/RESET & WDT	1	1	1	1	1	1	1	1
		Wake-up from Pin Change	P	P	P	P	P	P	P	P
0x07	Bank 1-R7	Bit Name	C77	C76	C75	C74	C73	C72	C71	C70
		Power-on	1	1	1	1	1	1	1	1
		/RESET & WDT	1	1	1	1	1	1	1	1
		Wake-up from Pin Change	P	P	P	P	P	P	P	P



Address	Name	Reset Type	Bit 7	Bit 6	Bit 5	Bit 4	Bit 3	Bit 2	Bit 1	Bit 0			
0x8	Bank 1-R8	Bit Name	-	-	-	ICE 220N	211N 212N	ICE 220N	211N 212N	ICE 220N	211N 212N	C81	C80
		Power-on	0	0	0	1	0	1	0	1	0	1	1
		/RESET & WDT	0	0	0	1	0	1	0	1	0	1	1
		Wake-up from Pin Change	P	P	P	P	P	P	P	P	P	P	P
0x9	Bank 1-R9 (Reserve)	Bit Name	-	-	-	-	-	-	-	-	-	-	-
		Power-on	0	0	0	0	0	0	0	0	0	0	0
		/RESET & WDT	0	0	0	0	0	0	0	0	0	0	0
		Wake-up from Pin Change	P	P	P	P	P	P	P	P	P	P	P
0xA	Bank 1-RA (CMPCON)	Bit Name	EIS1	EIS0	CMP OUT	CMP COS1	CMP COS0	-	-	-	-	-	-
		Power-on	0	0	0	0	0	0	0	0	0	0	0
		/RESET & WDT	0	0	0	0	0	0	0	0	0	0	0
		Wake-up from Pin Change	P	P	P	P	P	P	P	P	P	P	P
0xB	Bank 1-RB	Bit Name	/PD7	/PD6	/PD5	/PD4	/PD3	/PD2	/PD1	/PD0			
		Power-on	1	1	1	1	1	1	1	1	1		
		/RESET & WDT	1	1	1	1	1	1	1	1	1		
		Wake-up from Pin Change	P	P	P	P	P	P	P	P	P		
0xC	Bank 1-RC	Bit Name	/OD7	/OD6	/OD5	/OD4	/OD3	/OD2	/OD1	/OD0			
		Power-on	1	1	1	1	1	1	1	1	1		
		/RESET & WDT	1	1	1	1	1	1	1	1	1		
		Wake-up from Pin Change	P	P	P	P	P	P	P	P	P		
0xD	Bank 1-RD	Bit Name	/PH7	/PH6	/PH5	/PH4	/PH3	/PH2	/PH1	/PH0			
		Power-on	1	1	1	1	1	1	1	1	1		
		/RESET & WDT	1	1	1	1	1	1	1	1	1		
		Wake-up from Pin Change	P	P	P	P	P	P	P	P	P		
0xE	Bank 1-RE	Bit Name	WDTE	-	PSWE	PSW2	PSW1	PSW0	-	CMPIE			
		Power-on	0	0	0	0	0	0	0	0	0		
		/RESET & WDT	0	0	0	0	0	0	0	0	0		
		Wake-up from Pin Change	P	P	P	P	P	P	P	P	P		



Address	Name	Reset Type	Bit 7	Bit 6	Bit 5	Bit 4	Bit 3	Bit 2	Bit 1	Bit 0
0xF	Bank 1-RF	Bit Name	-	-	-	-	-	EXIE	ICIE	TCIE
		Power-on	0	0	0	0	0	0	0	0
		/RESET & WDT	0	0	0	0	0	0	0	0
		Wake-up from Pin Change	P	P	P	P	P	P	P	P
0x05	Bank 2-R5 (HDCR)	Bit Name	HD67	HD66	HD65	HD64	HD63	HD62	HD61	HD60
		Power-on	0	0	0	0	0	0	0	0
		/RESET & WDT	0	0	0	0	0	0	0	0
		Wake-up from Pin Change	P	P	P	P	P	P	P	P
0x06	Bank 2-R6 (HSCR1)	Bit Name	HS57	HS56	HS55	HS54	HS53	HS52	HS51	HS50
		Power-on	0	0	0	0	0	0	0	0
		/RESET & WDT	0	0	0	0	0	0	0	0
		Wake-up from Pin Change	P	P	P	P	P	P	P	P
0x07	Bank 2-R7 (HSCR2)	Bit Name	HS67	HS66	HS65	HS64	HS63	HS62	HS61	HS60
		Power-on	0	0	0	0	0	0	0	0
		/RESET & WDT	0	0	0	0	0	0	0	0
		Wake-up from Pin Change	P	P	P	P	P	P	P	P
0x8	Bank 2-R8 (OMCR)	Bit Name	-	-	-	-	-	-	-	-
		Power-on	U	1	1	1	U	U	U	U
		/RESET & WDT	P	1	1	1	P	P	P	P
		Wake-up from Pin Change	P	P	P	P	P	P	P	P
0x9 ~ 0xF	Bank 2-R9 (RF)	Bit Name	-	-	-	-	-	-	-	-
		Power-on	0	0	0	0	0	0	0	0
		/RESET & WDT	0	0	0	0	0	0	0	0
		Wake-up from Pin Change	P	P	P	P	P	P	P	P
0x05	Bank 3-R5 (TCC)	Bit Name	TCC7	TCC6	TCC5	TCC4	TCC3	TCC2	TCC1	TCC0
		Power-on	0	0	0	0	0	0	0	0
		/RESET & WDT	0	0	0	0	0	0	0	0
		Wake-up from Pin Change	P	P	P	P	P	P	P	P
0x06	Bank 3-R6 (IRC) (only for ICE)	Bit Name	C3	C2	C1	C0	RCM1	RCM0	-	-
		Power-on	1	1	1	1	1	1	U	U
		/RESET & WDT	1	1	1	1	1	1	P	P
		Wake-up from Pin Change	P	P	P	P	P	P	P	P

Address	Name	Reset Type	Bit 7	Bit 6	Bit 5	Bit 4	Bit 3	Bit 2	Bit 1	Bit 0
0x07	Bank 3-R7 (only for ICE)	Bit Name	-	-	-	-	NRHL	NRE	LVR1	LVR0-
		Power-on	U	U	U	U	1	1	1	1
		/RESET & WDT	P	P	P	P	1	1	1	1
		Wake-up from Pin Change	P	P	P	P	P	P	P	P
0x10 ~ 0x1F	R10 ~ R1F	Bit Name	-	-	-	-	-	-	-	-
		Power-on	U	U	U	U	U	U	U	U
		/RESET & WDT	P	P	P	P	P	P	P	P
		Wake-up from Pin Change	P	P	P	P	P	P	P	P
0x20 ~ 0x3F	Bank 0~3 R20 ~ R3F	Bit Name	-	-	-	-	-	-	-	-
		Power-on	U	U	U	U	U	U	U	U
		/RESET & WDT	P	P	P	P	P	P	P	P
		Wake-up from Pin Change	P	P	P	P	P	P	P	P

Legend: “x” = not used “P” = previous value before reset
 “u” = unknown or don't care “t” = check “Reset Type” Table in Section 6.5.2

6.5.1.3 Controller Reset Block Diagram

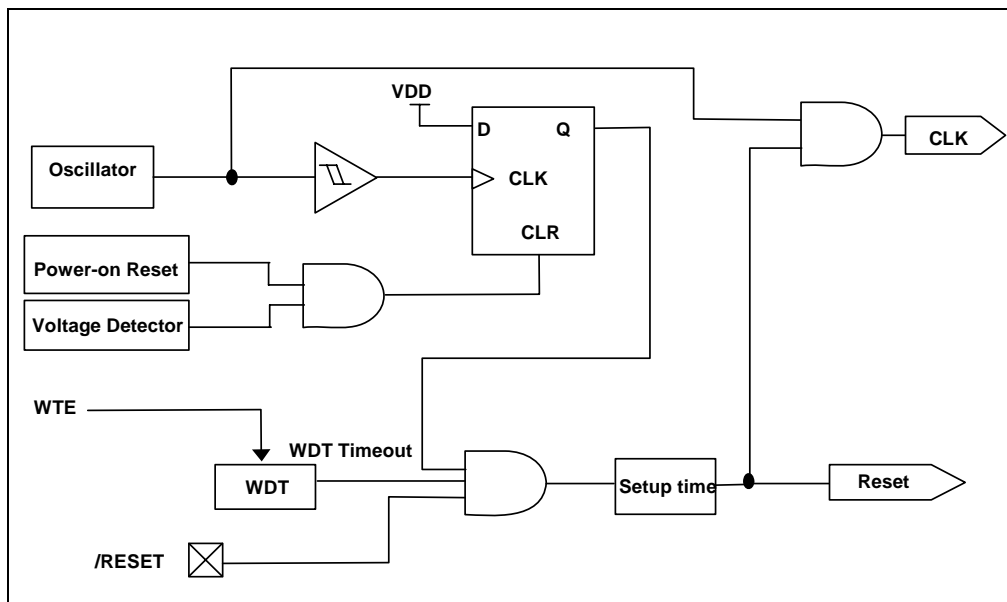

Fig. 6-7 Controller Reset Block Diagram

6.5.2 The T and P Status under Status Register

A reset condition is initiated by one of the following events:

1. Power-on reset
2. /RESET pin input "low"
3. WDT time-out (if enabled)

The values of T and P as listed in the table below, are used to check how the processor wakes up.

Reset Type	T	P
Power-on	1	1
/RESET during Operating mode	*P	*P
/RESET wake-up during Sleep mode	1	0
LVR during Operating mode,	*P	*P
LVR wake-up during SLEEP mode	1	0
WDT during Operating mode	0	*P
WDT wake-up during Sleep mode	0	0
Wake-up on pin change during Sleep mode	1	0

* P: Previous status before reset

The following shows the events that may affect the status of T and P.

Event	T	P
Power-on	1	1
WDTC instruction	1	1
WDT time-out	0	*P
SLEP instruction	1	0
Wake-up on pin changed during Sleep mode	1	0

* P: Previous value before reset

6.6 Interrupt

The EM78P221/2N has four interrupts as listed below:

1. TCC overflow interrupt
2. Port 6 Input Status Change Interrupt
3. External interrupt INT0, INT1
4. When the Comparator 1 output status changes

Before the Port 6 Input Status Change Interrupt is enabled, reading Port 6 (e.g., "MOV R6, R6") is necessary. Each Port 6 pin will have this feature if its status changes. Port 6 Input Status Change Interrupt will wake up the EM78P221/2N from sleep mode if it is enabled prior to going into sleep mode by executing SLEP. When wake-up occurs, the controller will continue to execute the succeeding program if the global interrupt is disabled. If enabled, it will branch out to the interrupt vector 008H.

The external interrupt has a built-in digital noise rejection circuit (if the input pulse is less than 8-system clock time, it is eliminated as noise. Edge selection is possible with /INT. Refer to Word 1 Bits 8~7 (Section 6.13.2, *Code Option Register (Word 1)*) for digital noise rejection definition.

During a power source unstable situation, like during external power noise interference or EMS test condition, it will cause the power to vibrate fiercely. While Vdd is still unsettled, the supply voltage may be below working voltage. When the system supply voltage Vdd is below the working voltage, the IC kernel must automatically keep all register status.

Bank 0-RE and Bank 0-RF are the interrupt status register that records the interrupt requests in the relative flags/bits. Bank 1-RE and Bank 1-RF are interrupt mask registers. The global interrupt is enabled by the ENI instruction and is disabled by the DISI instruction. When one of the interrupts (when enabled) occurs, the next instruction will be fetched from Address 008H. Once in the interrupt service routine, the source of an interrupt can be determined by polling the flag bits in Bank 0-RE and Bank 0-RF. The interrupt flag bit must be cleared by instructions before leaving the interrupt service routine to avoid recursive interrupts.

When interrupt mask bits is "Enable", the flag in the Interrupt Status Register (RF) is set regardless of the ENI execution. Note that the result of Bank 0-RE/RF will be the logic AND of BANK 0-RE/RF and Bank 1-RE/RF (refer to Fig. 6-8). The RETI instruction ends the interrupt routine and enables the global interrupt (the ENI execution).

When any interrupt occurs, the contents of ACC, R1 (Bits 5, 4, 1, 0), R3 (Bits 2 ~0), R4 registers are pushed to the corresponding stack (Fig 6-9). After the RETI instruction is executed, the content of the corresponding stack are popped to ACC, R1 (Bits 5, 4, 1, 0), R3 (Bits 2 ~0), R4 registers.

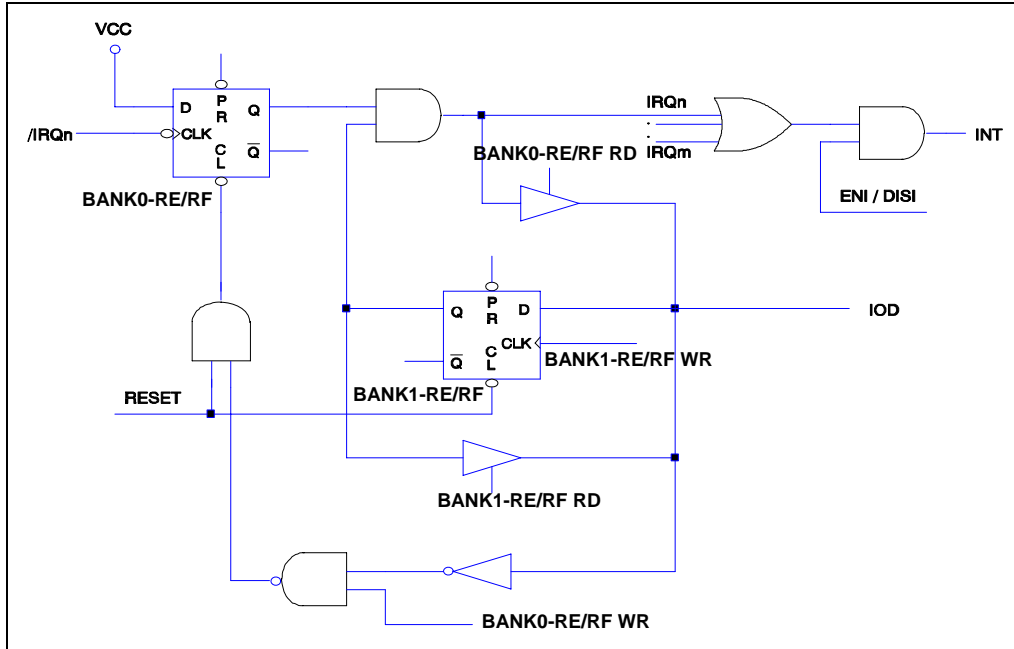

Fig. 6-8 Interrupt Input Circuit

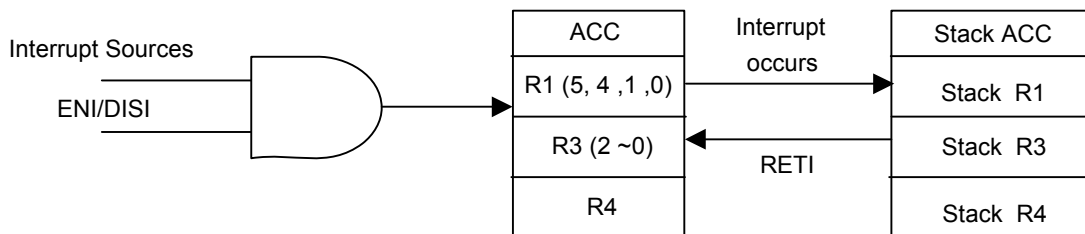

Fig. 6-9 Interrupt Backup Diagram

6.7 Comparator

The EM78P221/2N has one comparator comprising of two analog inputs and one output. The comparator can be utilized to wake up the EM78P221/2N from sleep mode. The comparator circuit diagram is depicted in the figure below.

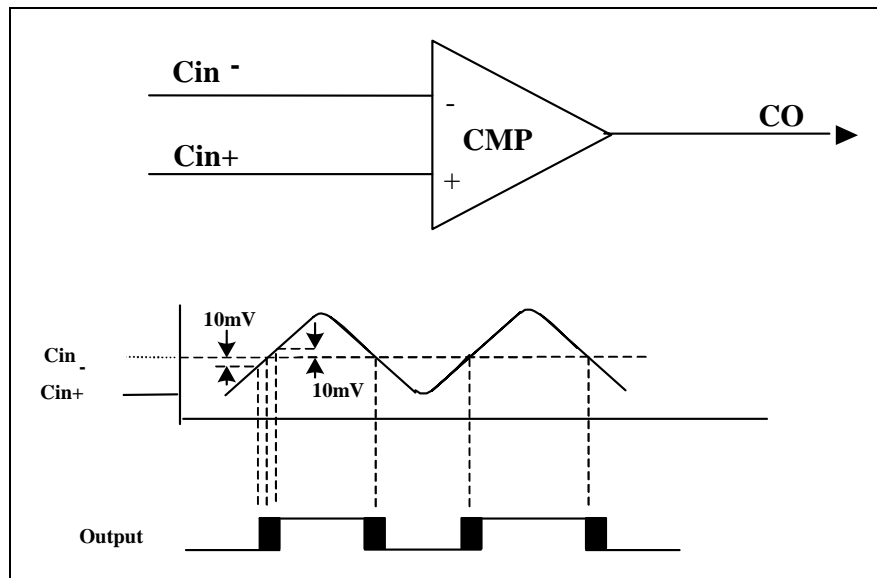

Fig. 6-10 Comparator Circuit Diagram & Operating Mode

6.7.1 External Reference Signal

The analog signal presented at Cin- compares to the signal at Cin+, and the digital output (CO) of the comparator is adjusted accordingly by taking the following notes into considerations:

NOTE

- The reference signal must be between V_{ss} and V_{dd} .
- The reference voltage can be applied to either pin of the comparator.
- Threshold detector applications may be of the same reference.
- The comparator can operate from the same or different reference sources.

6.7.2 Comparator Outputs

- The compared result is stored in the CMPOUT of Bank 1-RA.
- Bits 3 ~ 4 <CMPCOS1, CMPCOS0> of the Bank 1-RA register. See Section 6.2.18, *Bank 1-RA (CMPCON: Comparator Control Register)* for Comparator select bits function description.

NOTE

- The highest priority of P71/INT1/CO is INT1. When EIS1=0, the working type of P71/INT1/CO is determined by CMPCOS1 and CMPCOS2.
- The CO and P71 of the P71/CO pins cannot be used at the same time.
- The P71/CO pin priority is as follows:

P71/INT1/CO Pin Priority		
High	Medium	Low
/INT1	CO	P71

The following figure shows the Comparator Output block diagram.

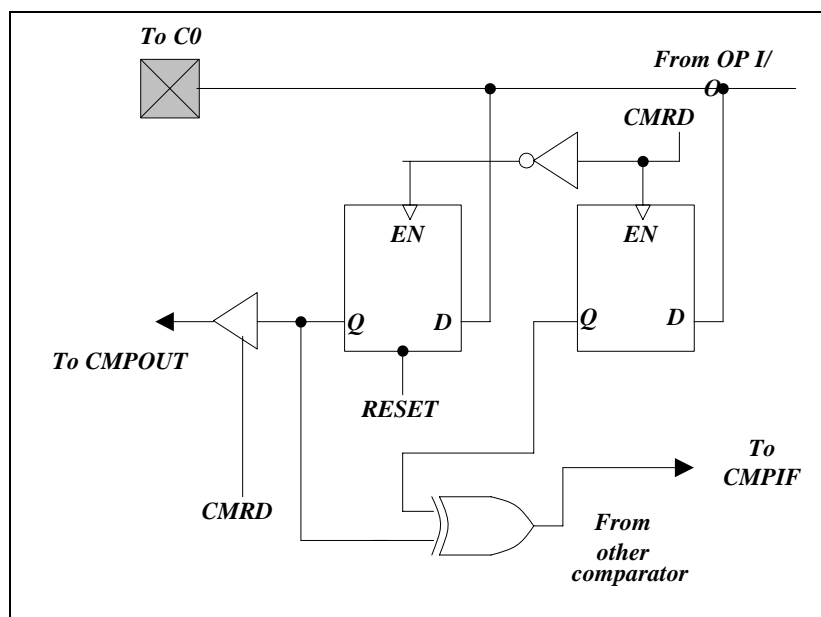

Fig. 6-11 Comparator Output Configuration

6.7.3 Using a Comparator as an Operation Amplifier

6.7.3.1 Bank 0-RE (WUCR: Wake-up Control Register)

Bit 7	Bit 6	Bit 5	Bit 4	Bit 3	Bit 2	Bit 1	Bit 0
EX1IF	0	0	ICWE	0	CMPWE	0	CMPIF

Bit 2 (CMPWE): Comparator wake-up enable bit
0 = Disable Comparator wake-up
1 = Enable Comparator wake-up

When the Comparator output status change is used to enter an interrupt vector or to wake-up the EM78P221/2N from sleep, the CMPWE bit must be set to "Enable".

Bit 0 (CMPIF): Comparator interrupt flag. Set when a change occurs in the Comparator output. Reset by software

6.7.3.2 Bank 1-RA (CMPCON: Comparator Control Register)

Bit 7	Bit 6	Bit 5	Bit 4	Bit 3	Bit 2	Bit 1	Bit 0
EIS1	EIS0	CMPOUT	CMPCOS1	CMPCOS0	0	0	0

Bit 5 (CMPOUT): The result of the Comparator output

Bit 4 ~ Bit 3 (CMPCOS1 ~ CMPCOS0): Comparator Select bits

CMPCOS1	CMPCOS0	Function Description
0	0	Comparator is not used. P72, P73 and P71 are normal I/O pins
0	1	P72 and P73 are Comparator input pins and P71 is normal I/O pin
1	0	P72 and P73 are Comparator input pins and P71 is Comparator output pin (CO)
1	1	Used as OP and P71 is OP output pin (CO)

6.7.3.3 Bank 1-RE (WDT Control Register)

Bit 7	Bit 6	Bit 5	Bit 4	Bit 3	Bit 2	Bit 1	Bit 0
WDTE	0	PSWE	PSW2	PSW1	PSW0	0	CMPIE

Bit 0 (CMPIE): CMPIF interrupt enable bit
0 = Disable CMPIF interrupt
1 = Enable CMPIF interrupt

When the Comparator output status change is used to enter an interrupt vector or to enter the next instruction, the CMPIE bit must be set to "Enable". But actually the comparator output must be read to latch the status at first. Then the comparator output is compared to this latch to produce the information of output status change.

6.7.4 Comparator Interrupt

- CMPIE must be enabled for the "ENI" instruction to take effect
- Interrupt is triggered whenever a change occurs on the comparator output pin
- The actual change on the pin can be determined by reading the Bit CMPOUT
- CMPIF the comparator interrupt flag, can only be cleared by software

6.7.5 Wake-up from Sleep Mode

- If enabled, the comparator remains active and the interrupt remains functional, even in Sleep mode.
- If a mismatch occurs, the interrupt will wake up the device from Sleep mode.
- The power consumption should be taken into consideration for the benefit of energy conservation.
- If the function is unemployed during Sleep mode, turn off the comparator before entering sleep mode.

6.8 Oscillator

6.8.1 Oscillator Modes

The EM78P221/2N can be operated in six different oscillator modes, such as High Crystal oscillator mode (HXT 1, 2), Low Crystal oscillator mode (LXT 1, 2), External RC oscillator mode (ERC), and RC oscillator mode with Internal RC oscillator (IRC). Select one of such modes by programming the OSC2, OCS1, and OSC0 in the Code Option register.

The Oscillator modes defined by OSC2, OCS1, and OSC0 are described below.

Oscillator Modes	OSC2	OSC1	OSC0
ERC ¹ (External RC oscillator mode); P52/OSCO act as P52	0	0	0
ERC ¹ (External RC oscillator mode); P52/OSCO act as OSCO	0	0	1
IRC ² (Internal RC oscillator mode); P52/OSCO act as P52	0	1	0
IRC ² (Internal RC oscillator mode); P52/OSCO act as OSCO	0	1	1
LXT1 ³ (Frequency range of XT mode is 1MHz~100kHz)	1	0	0
HXT1 ³ (Frequency range of XT mode is 16MHz~6MHz)	1	0	1
LXT2 ³ (Frequency range of XT mode is 32kHz)	1	1	0
HXT2 ³ (Frequency range of XT mode is 6MHz~1MHz) (Default)	1	1	1

¹ In ERC mode, OSC1 is used as oscillator pin. OSCO/P52 is defined by code option Word 0 Bit 6 ~ Bit 4.

² In IRC mode, P53 is normal I/O pin. OSCO/P52 is defined by code option Word 0 Bit 6 ~ Bit 4.

³ In LXT1, LXT2, HXT1 and HXT2 modes; OSC1 and OSC0 are used as oscillator pins. These pins cannot and should not be defined as normal I/O pins.

The maximum operating frequency limit of the crystal/resonator at different VDDs, are as follows:

Conditions	VDD	Max. Freq. (MHz)
Two clocks	2.1	4
	3.0	8
	4.5	16

6.8.2 Crystal Oscillator/Ceramic Resonators (Crystal)

The EM78P221/2N can be driven by an external clock signal through the OSCO pin as illustrated below.

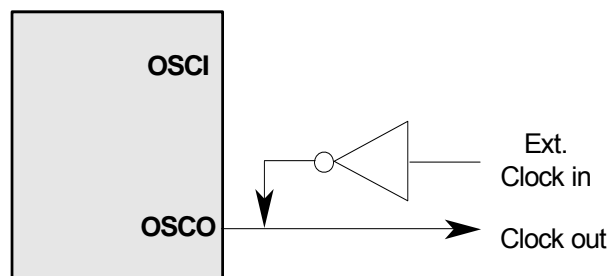

Fig. 6-12 External Clock Input Circuit

In most applications, Pin OSCI and Pin OSCO can be connected with a crystal or ceramic resonator to generate oscillation. Fig. 6-13 below depicts such a circuit. The same applies to the HXT 1, 2 modes and the LXT 1, 2 modes.

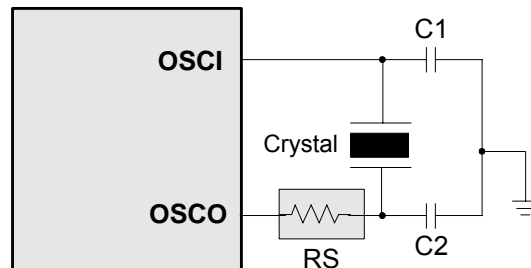

Fig. 6-13 Crystal/Resonator Circuit

The following table provides the recommended values for C1 and C2. Since each resonator has its own attribute, user should refer to the resonator specifications for appropriate values of C1 and C2. RS, a serial resistor, may be required for AT strip cut crystal or low frequency mode. Fig 6-13-1 is a recommended PCB layout. When the system works in Crystal mode (16MHz), a 10KΩ is connected between OSCI and OSCO.

Capacitor selection guide for crystal oscillator or ceramic resonators:

Oscillator Type	Frequency Mode	Frequency	C1 (pF)	C2 (pF)
Ceramic Resonators	LXT (100K~1MHz)	100kHz	67pF	67pF
		200kHz	30pF	30pF
		455kHz	30pF	30pF
		1MHz	30pF	30pF
	HXT (1M~6MHz)	1.0 MHz	30pF	30pF
		2.0 MHz	30pF	30pF
4.0 MHz		30pF	30pF	
Crystal Oscillator	LXT2 (32.768kHz)	32.768kHz	20pF	20pF
	LXT1 (100K~1MHz)	100kHz	67pF	67pF
		200kHz	30pF	30pF
		455kHz	30pF	30pF
		1MHz	30pF	30pF
	HXT2 (1~6MHz)	455kHz	30pF	30pF
		1.0 MHz	30pF	30pF
		2.0 MHz	30pF	30pF
		4.0 MHz	30pF	30pF
		6.0 MHz	30pF	30pF
	HXT1 (6~16MHz)	6.0 MHz	30pF	30pF
		8.0 MHz	30pF	30pF
		12.0 MHz	30pF	30pF
16.0 MHz		15pF	15pF	

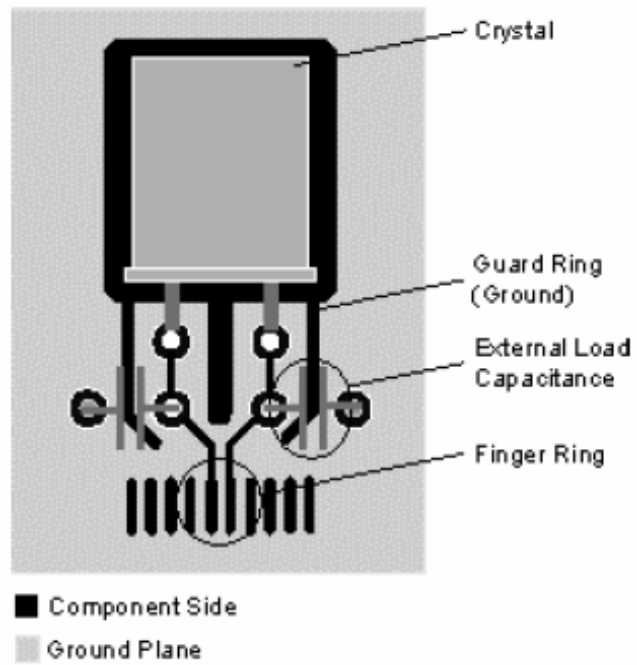

Fig. 6-13-1 Parallel Mode Crystal/Resonator Circuit Diagram

6.8.3 External RC Oscillator Mode

For some applications that do not require precise timing calculation, the RC oscillator (Fig. 6-14) could offer a cost-effective oscillator configuration. Nevertheless, it should be noted that the frequency of the RC oscillator is influenced by the supply voltage, the values of the resistor (Rext), the capacitor (Cext), and even by the operation temperature. Moreover, the frequency also changes slightly from one chip to another due to manufacturing process variations.

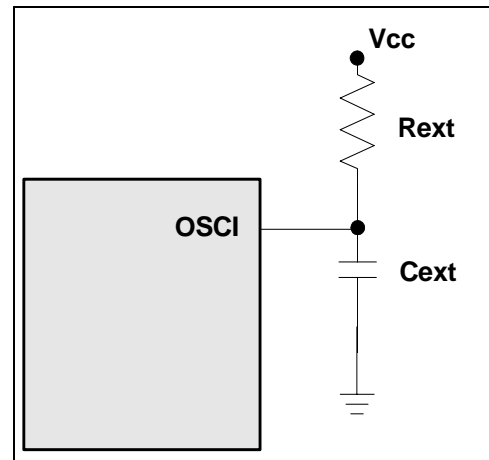

Fig. 6-14 External RC Oscillator Mode Circuit

In order to maintain a stable system frequency, the values of the Cext should not be less than 20pF, and the value of Rext should not be greater than 1MΩ. If the frequency cannot be kept within this range, the frequency can be easily affected by noise, humidity, and leakage.

The smaller the Rext in the RC oscillator, the faster its frequency will be. On the contrary, for very low Rext values, for instance, 1 KΩ, the oscillator will become unstable because the NMOS cannot discharge the capacitance current correctly.

Based on the above reasons, it must be kept in mind that all the supply voltage, the operation temperature, the components of the RC oscillator, the package types, and the PCB is layout, have certain effect on the system frequency.

The RC Oscillator frequencies:

Cext	Rext	Average Fosc 5V, 25°C	Average Fosc 3V, 25°C
20 pF	3.3k	3.5 MHz	3.2 MHz
	5.1k	2.5 MHz	2.3 MHz
	10k	1.30 MHz	1.25 MHz
	100k	140 kHz	140 kHz
100 pF	3.3k	1.27 MHz	1.21 MHz
	5.1k	850 kHz	820 kHz
	10k	450 kHz	450 kHz
	100k	48 kHz	50 kHz
300 pF	3.3k	560 kHz	540 kHz
	5.1k	370 kHz	360 kHz
	10k	196 kHz	192 kHz
	100k	20 kHz	20 kHz

Note: ¹: Measured based on DIP packages.
²: The values are for design reference only.
³: The frequency drift is ± 30%

6.8.4 Internal RC Oscillator Mode

The EM78P221/2N offers a versatile internal RC mode with default frequency value of 4MHz. Internal RC oscillator mode has other frequencies (1MHz, 16MHz, and 455kHz) that can be set by Code Option (Word 1), RCM1, and RCM0. The Table below describes the EM78P221/2N internal RC drift with the variations on voltage, temperature, and process.

Internal RC Drift Rate ($T_a=25^{\circ}\text{C}$, $V_{DD}=5.0\text{V} \pm 5\%$, $V_{SS}=0\text{V}$)

Internal RC Frequency	Drift Rate			
	Temperature (-40°C~+85°C)	Voltage (2.1V~5.5V)	Process	Total
4MHz	±5%	±5%	±4%	±14%
16MHz	±5%	±5%	±4%	±14%
1MHz	±5%	±5%	±4%	±14%
455kHz	±5%	±5%	±4%	±14%

Theoretical values are for reference only. Actual values may vary depending on actual process.

6.9 Power-on Considerations

Any microcontroller is not warranted to start operating properly before the power supply stabilizes to a steady state. EM78P221/2N has a built-in Power-on Voltage Detector (POVD) with detection level range of 1.7V to 1.9V. The circuitry eliminates the extra external reset circuit. It will work well if V_{dd} rises quickly enough (50 ms or less). However, under critical applications, extra devices are still required to assist in solving power-on problems.

6.9.1 External Power-on Reset Circuit

The circuit shown in the following figure implements an external RC to produce a reset pulse. The pulse width (time constant) should be kept long enough to allow V_{dd} to reach the minimum operating voltage. This circuit is used when the power

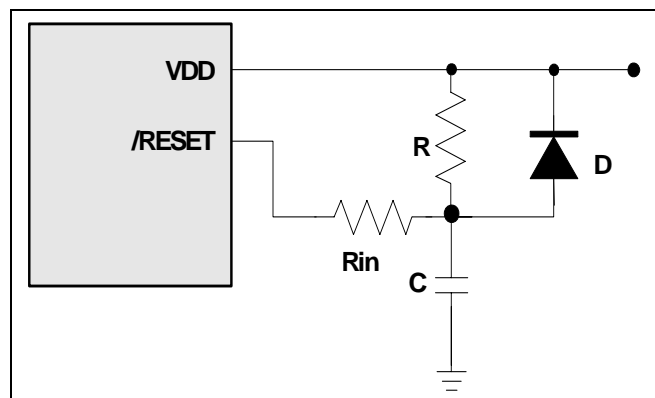

Fig. 6-15 External Power on Reset Circuit

supply has a slow power rise time. Since the current leakage from the /RESET pin is about $\pm 5\mu\text{A}$, it is recommended that R should not be greater than 40K. This way, the voltage at Pin /Reset is held below 0.2V. The diode (D) functions as a short circuit at power-down. The "C" capacitor is discharged rapidly and fully. Rin, the current-limited resistor, prevents high current discharge or ESD (electrostatic discharge) from flowing into Pin /RESET.

6.9.2 Residual Voltage Protection

When the battery is replaced, device power V_{dd} is removed but residual voltage remains. The residual voltage may trip below V_{dd} minimum, but not to zero. This condition may cause a poor power-on reset. Fig. 6-16 and Fig. 6-17 show how to create a protection circuit against residual voltage.

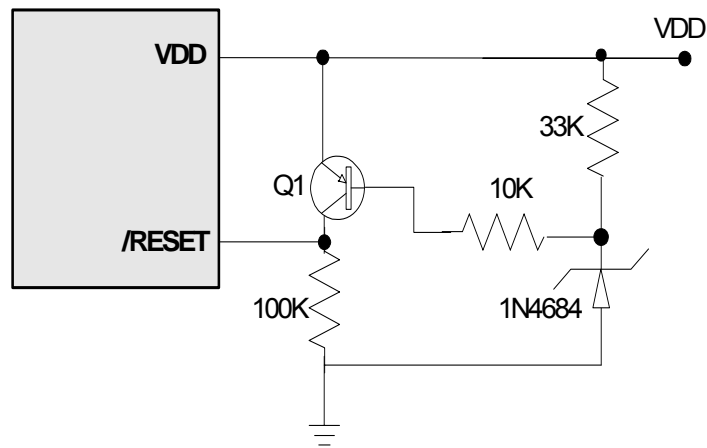

Fig. 6-16 Residual Voltage Protection Circuit 1

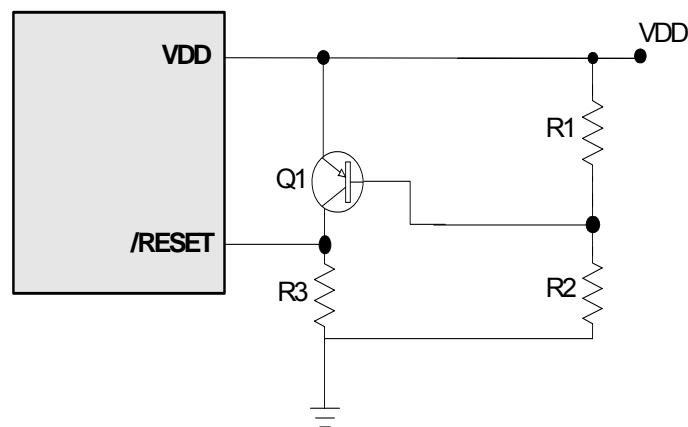

Fig. 6-17 Residual Voltage Protection Circuit 2

6.10 Low Voltage Reset

Low voltage reset (LVR) is designed for unstable power situation, such as external power noise interference or in EMS test condition.

When LVR is enabled, the system supply voltage (V_{dd}) drops below V_{dd} reset level (V_{RESET}) and remains at 10μs, system reset will occur and the system will remain at reset status. The system will remain at reset status until V_{dd} voltage rises above V_{dd} release level. Refer to Fig 6-18.

LVR characteristics are set at Code Option Word 0, Bits 10 and 9. Detailed operation mode is as follows:

Word 0												
Bit 12	Bit 11	Bit 10	Bit 9	Bit 8	Bit 7	Bit 6	Bit 5	Bit 4	Bit 3	Bit 2	Bit 1	Bit 0
TYPE1	TYPE0	LVR1	LVR0	CLKS	ENMDBT	OSC2	OSC1	OSC0	-	PR2	PR1	PR0

Bits 10~9 (LVR1 ~ LVR0): Low Voltage Reset enable bits. If Vdd has crossover at Vdd reset level as Vdd changes, the system will reset.

LVR1, LVR0	VDD Reset Level	VDD Release Level
11	NA (Power-on Reset) (default)	
10	2.5V	2.7V
01	3.0V	3.2V
00	4.0V	4.2V

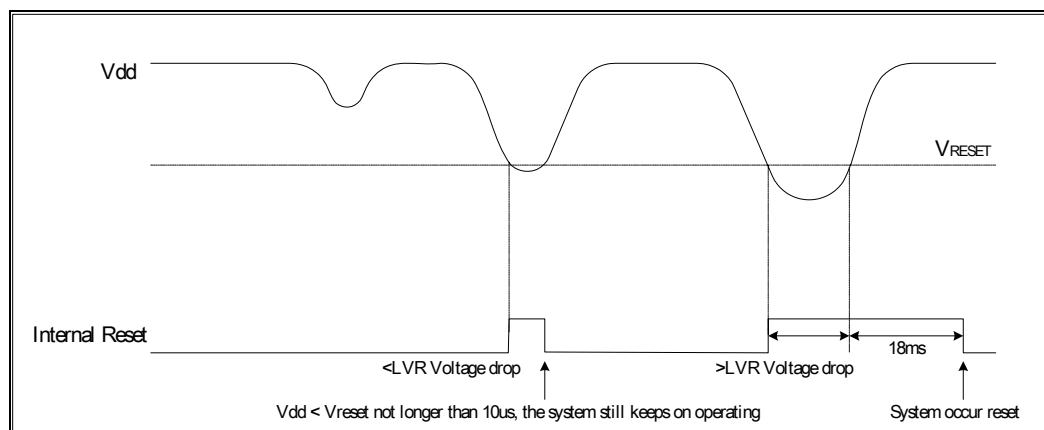

Fig. 6-18 LVR Waveform Situation

6.11 Code Option

EM78P221/2N has two Code Option Words and one Customer ID word that are not a part of the normal program memory.

Word 0	Word 1	Word 2
Bit 12 ~ Bit 0	Bit 12 ~ Bit 0	Bit 12 ~ Bit 0

6.11.1 Code Option Register (Word 0)

Word 0												
Bit 12	Bit 11	Bit 10	Bit 9	Bit 8	Bit 7	Bit 6	Bit 5	Bit 4	Bit 3	Bit 2	Bit 1	Bit 0
TYPE1	TYPE0	LVR1	LVR0	CLKS	ENMDBT	OSC2	OSC1	OSC0	-	PR2	PR1	PR0

Bits 12 ~ 11 (Type 1, Type 0): Type selection for EM78P221N or EM78P222N

Type 1, Type 0	MCU Type
00	Not for use
01	Not for use
10	EM78P221N (24 pins)
11	EM78P222N (28 pins)

Note: LVR1 and LVR0 are at Bank 3-R7, when using ICE.

Bits 10 ~ 9 (LVR1 ~ LVR0): Low Voltage Reset control bits

LVR1, LVR0	VDD Reset Level	VDD Release Level
11	NA (Power-on Reset) (Default)	
10	2.5V	2.7V
01	3.0V	3.2V
00	4.0V	4.2V

Bit 8 (CLKS): Instruction time period option bit
0 = two oscillator time periods
1 = four oscillator time periods (**Default**)
Refer to Section 6.12 for Instruction Set

Bit 7 (ENWDTB): Watchdog timer enable bit
0 = Enable
1 = Disable (default)

Bits 6, 5 & 4 (OSC2, OSC1 & OSC0): Oscillator Mode Selection bits

Oscillator Modes	OSC2	OSC1	OSC0
ERC ¹ (External RC oscillator mode); P52/OSCO act as P52	0	0	0
ERC ¹ (External RC oscillator mode); P52/OSCO act as OSC0	0	0	1
IRC ² (Internal RC oscillator mode); P52/OSCO act as P52	0	1	0
IRC ² (Internal RC oscillator mode); P52/OSCO act as OSC0	0	1	1
LXT1 ³ (Frequency range of XT mode is 1MHz~100kHz)	1	0	0
HXT1 ³ (Frequency range of XT mode is 16MHz~6MHz)	1	0	1
LXT2 ³ (Frequency range of XT mode is 32kHz)	1	1	0
HXT2 ³ (Frequency range of XT mode is 6MHz~1MHz) (Default)	1	1	1

¹ In ERC mode, OSC1 is used as oscillator pin. OSC0/P52 is defined by code option Word 0 Bit 6 ~ Bit 4.
² In IRC mode, P53 is normal I/O pin. OSC0/P52 is defined by code option Word 0 Bit 6 ~ Bit 4.
³ In LXT1, LXT2, HXT1 and HXT2 modes; OSC1 and OSC0 are used as oscillator pins. These pins cannot and should not be defined as normal I/O pins.

Bit 3: Not used (Reserved). This bit is set to 0 all the time

Bits 2 ~ 0 (PR2 ~ PR0): Protect Bits

PR2 ~ PR0 are protect bits. Each protect status is as follows:

PR2	PR1	PR0	Protect
0	0	0	Enable
1	1	1	Disable (Default)

6.11.2 Code Option Register (Word 1)

Word 1												
Bit 12	Bit 11	Bit 10	Bit 9	Bit 8	Bit 7	Bit 6	Bit 5	Bit 4	Bit 3	Bit 2	Bit 1	Bit 0
-	-	RESET ENB	RCOUT	NRHL	NRE	-	C3	C2	C1	C0	RCM1	RCM0

Bit 12: Not used (reserved), fixed to “1” all the time.

Bit 11: Not used (reserved), fixed to “0” all the time.

Bit 10 (RESETENB): P81/RESET pin select bit

0 = P81 set as /RESET pin

1 = P81 is general purpose input pin or open drain for output port

(Default)

Bit 9 (RCOUT): System clock output enable bit in IRC or ERC mode

0 = OSCO pin is open drain

1 = OSCO output instruction clock **(Default)**

Bit 8 (NRHL): Noise rejection high/low pulse define bit. INT pin has a falling edge trigger.

0 = Pulses equal to $8/f_c$ are regarded as signal

1 = Pulses equal to $32/f_c$ are regarded as signal **(Default)**

NOTE

NRHL and NRE are at Bank 3-R7, when using ICE.

Bit 7 (NRE): Noise rejection enable

0 = disable noise rejection

1 = enable noise rejection (default). However in Low Crystal oscillator (LXT2) mode, the noise rejection circuit is always disabled.

NOTE

The noise rejection function is turned off in LXT2 and sleep mode.

Bit 6: Not used (Reserved). This bit is set to “1” all the time.

NOTE

C3, C2, C1, C0, RCM1 and RCM0 are at Bank 3-R6, when using ICE.

Bits 5~2 (C3~C0): Internal RC mode Calibration bits. These bits must always be set to “1” only (auto calibration)



Bit 1 & Bit 0 (RCM1 & RCM0): RC mode selection bits

RCM 1	RCM 0	Frequency (MHz)
1	1	4 (Default)
1	0	16
0	1	1
0	0	455kHz

6.11.3 Customer ID Register (Word 2)

Word 2												
Bit 12	Bit 11	Bit 10	Bit 9	Bit 8	Bit 7	Bit 6	Bit 5	Bit 4	Bit 3	Bit 2	Bit 1	Bit 0
-	NRM	-	-	ID8	ID7	ID6	ID5	ID4	ID3	ID2	ID1	ID0

Bit 12: Not used (reserved), fixed to "0" all the time

Bit 11 (NRM):

0 = Noise reject Mode 2. For multi-time circuit use, such as key scan and LED output.

1 = Noise reject Mode 1. For General input or output use. **(Default)**

Bits 10~9: Not used (reserved), fixed to "1" all the time

Bits 8 ~ 0: Customer's ID code

6.12 Instruction Set

Each instruction in the instruction set is a 13-bit word divided into an OP code and one or more operands. Normally, all instructions are executed within one single instruction cycle (one instruction consists of 2 oscillator time periods). Note the program counter is changed by instructions "MOV R2,A," "ADD R2,A," or by instructions of arithmetic or logic operation on R2 (e.g., "SUB R2,A," "BS(C) R2,6," "CLR R2," etc.). In this case, these instructions only need one instruction cycles

In addition, the instruction set has the following features:

1. Every bit of any register can be set, cleared, or tested directly.
2. The I/O registers can be regarded as general registers. That is, the same instruction can operate on I/O registers.

Convention:

R = Register designator that specifies which one of the registers (including operation and general purpose registers) is to be utilized by the instruction.

b = Bit field designator that selects the value for the bit located in the register R and which affects the operation.

k = 8 or 10-bit constant or literal value



Binary Instruction	HEX	Mnemonic	Operation	Status Affected
0 0000 0000 0000	0000	NOP	No Operation	None
0 0000 0000 0001	0001	DAA	Decimal Adjust A	C
0 0000 0000 0010	0002	CONTW	A → CONT	None
0 0000 0000 0011	0003	SLEP	0 → WDT, Stop oscillator	T, P
0 0000 0000 0100	0004	WDTC	0 → WDT	T, P
0 0000 0001 0000	0010	ENI	Enable Interrupt	None
0 0000 0001 0001	0011	DISI	Disable Interrupt	None
0 0000 0001 0010	0012	RET	[Top of Stack] → PC	None
0 0000 0001 0011	0013	RETI	[Top of Stack] → PC, Enable Interrupt	None
0 0000 0001 0100	0014	CONTR	CONT → A	None
0 0000 01rr rrrr	00rr	MOV R,A	A → R	None
0 0000 1000 0000	0080	CLRA	0 → A	Z
0 0000 11rr rrrr	00rr	CLR R	0 → R	Z
0 0001 00rr rrrr	01rr	SUB A,R	R-A → A	Z, C, DC
0 0001 01rr rrrr	01rr	SUB R,A	R-A → R	Z, C, DC
0 0001 10rr rrrr	01rr	DECA R	R-1 → A	Z
0 0001 11rr rrrr	01rr	DEC R	R-1 → R	Z
0 0010 00rr rrrr	02rr	OR A,R	A ∨ VR → A	Z
0 0010 01rr rrrr	02rr	OR R,A	A ∨ VR → R	Z
0 0010 10rr rrrr	02rr	AND A,R	A & R → A	Z
0 0010 11rr rrrr	02rr	AND R,A	A & R → R	Z
0 0011 00rr rrrr	03rr	XOR A,R	A ⊕ R → A	Z
0 0011 01rr rrrr	03rr	XOR R,A	A ⊕ R → R	Z
0 0011 10rr rrrr	03rr	ADD A,R	A + R → A	Z, C, DC
0 0011 11rr rrrr	03rr	ADD R,A	A + R → R	Z, C, DC
0 0100 00rr rrrr	04rr	MOV A,R	R → A	Z
0 0100 01rr rrrr	04rr	MOV R,R	R → R	Z
0 0100 10rr rrrr	04rr	COMA R	/R → A	Z
0 0100 11rr rrrr	04rr	COM R	/R → R	Z
0 0101 00rr rrrr	05rr	INCA R	R+1 → A	Z

Binary Instruction	HEX	Mnemonic	Operation	Status Affected
0 0101 01rr rrrr	05rr	INC R	R+1 → R	Z
0 0101 10rr rrrr	05rr	DJZA R	R-1 → A, skip if zero	None
0 0101 11rr rrrr	05rr	DJZ R	R-1 → R, skip if zero	None
0 0110 00rr rrrr	06rr	RRCA R	R(n) → A(n-1), R(0) → C, C → A(7)	C
0 0110 01rr rrrr	06rr	RRC R	R(n) → R(n-1), R(0) → C, C → R(7)	C
0 0110 10rr rrrr	06rr	RLCA R	R(n) → A(n+1), R(7) → C, C → A(0)	C
0 0110 11rr rrrr	06rr	RLC R	R(n) → R(n+1), R(7) → C, C → R(0)	C
0 0111 00rr rrrr	07rr	SWAPA R	R(0-3) → A(4-7), R(4-7) → A(0-3)	None
0 0111 01rr rrrr	07rr	SWAP R	R(0-3) ↔ R(4-7)	None
0 0111 10rr rrrr	07rr	JZA R	R+1 → A, skip if zero	None
0 0111 11rr rrrr	07rr	JZ R	R+1 → R, skip if zero	None
0 100b brrr rrrr	0xxx	BC R,b	0 → R(b)	None ¹
0 101b brrr rrrr	0xxx	BS R,b	1 → R(b)	None ²
0 110b brrr rrrr	0xxx	JBC R,b	if R(b)=0, skip	None
0 111b brrr rrrr	0xxx	JBS R,b	if R(b)=1, skip	None
1 00kk kkkk kkkk	1kkk	CALL k	PC+1 → SP, (lower 10 bits of k) → PC	None
1 01kk kkkk kkkk	1kkk	JMP k	(lower 10 bits of k) → PC	None
1 1000 kkkk kkkk	18kk	MOV A,k	k → A	None
1 1001 kkkk kkkk	19kk	OR A,k	A ∨ k → A	Z
1 1010 kkkk kkkk	1Akk	AND A,k	A & k → A	Z
1 1011 kkkk kkkk	1Bkk	XOR A,k	A ⊕ k → A	Z
1 1100 kkkk kkkk	1Ckk	RETL k	k → A, [Top of Stack] → PC	None
1 1101 kkkk kkkk	1Dkk	SUB A,k	k-A → A	Z,C,DC
1 1110 1001 kkkk	1E9k	BANK k	k → R1(1:0)	None
1 1110 1010 kkkk k kkkk kkkk kkkk	1EAK	LCALL k	Next instruction: k kkkk kkkk kkkk; PC+1 → [SP], k → PC	None
1 1110 1011 kkkk k kkkk kkkk kkkk	1EBk	LJMP k	Next instruction: k kkkk kkkk kkkk; k → PC	None
1 1111 kkkk kkkk	1Fkk	ADD A,k	k+A → A	Z, C, DC

Note: ¹ This instruction is not recommended for RF operation

² This instruction cannot operate under RF.

7 Absolute Maximum Ratings

Items	Rating		
Temperature under bias	-40°C	to	85°C
Storage temperature	-65°C	to	150°C
Input voltage	V _{ss} -0.3V	to	V _{dd} +0.5V
Output voltage	V _{ss} -0.3V	to	V _{dd} +0.5V
Working Voltage	2.3V	to	5.5V
Working Frequency	DC	to	16MHz

8 DC Electrical Characteristics

T_a = 25°C, V_{DD} = 5.0V, V_{SS} = 0V

Symbol	Parameter	Condition	Min.	Typ.	Max.	Unit
FXT	Crystal: VDD to 5V	Two cycles with two clocks	DC	–	16	MHz
	ERC: VDD to 5V	R: 5.1KΩ, C: 100 pF	F±30%	850	F±30%	kHz
VIHRC	Input High Threshold Voltage (Schmitt Trigger)	OSCI in RC mode	–	3.75	–	V
VILRC	Input Low Threshold Voltage (Schmitt Trigger)	OSCI in RC mode	–	1.25	–	V
IIL	Input Leakage Current for input pins	V _{IN} = V _{DD} , V _{SS}	-1.0	0	1.0	μA
VIH1	Input High Voltage (Schmitt Trigger)	Ports 5, 6, 7, 8	–	3.75	–	V
VIL1	Input Low Voltage (Schmitt Trigger)	Ports 5, 6, 7, 8	–	1.25	–	V
VIHT1	Input High Threshold Voltage (Schmitt Trigger)	/RESET	–	1.9	–	V
VILT1	Input Low Threshold Voltage (Schmitt Trigger)	/RESET	–	1.2	–	V
VIHT2	Input High Threshold Voltage (Schmitt Trigger)	TCC, INT	–	3.75	–	V
VILT2	Input Low Threshold Voltage (Schmitt Trigger)	TCC, INT	–	1.25	–	V
VIHX1	Clock Input High Voltage	OSCI in crystal mode	–	3.75	–	V
VILX1	Clock Input Low Voltage	OSCI in crystal mode	–	1.25	–	V
IOH1	Output High Voltage (Ports 5, 6, 7, 8)	VOH = 0.9VDD	–	-9	–	mA
IOH2	Output High Voltage (Ports 6)	VOH = 0.7VDD	–	-27	–	mA
IOL1	Output Low Voltage (Ports 5, 6, 7, 8)	VOL = 0.1VDD	–	16.8	–	mA
IOL2	Output Low Voltage (Ports 5, 6)	VOL = 0.3VDD	–	67.2	–	mA

Symbol	Parameter	Condition	Min.	Typ.	Max.	Unit
IPH	Pull-high current (Ports 50~53, 64~67)	Pull-high active, input pin at VSS	50	–	90	μA
IPL	Pull-low current (Ports 60~67)	Pull-low active, input pin at Vdd	20	–	60	μA
ISB1	Power down current	All input and I/O pins at VDD, Output pin floating, LVR disabled WDT disabled,	–	2	–	μA
ISB2	Power down current	All input and I/O pins at VDD, Output pin floating, LVR Disabled WDT enabled,	–	10	–	μA
ISB3	Power down current	All input and I/O pins at VDD, Output pin floating, LVR enabled WDT disabled	–	4.0	–	μA
ICC1	Operating supply current at two clocks (VDD=3V)	/RESET= 'High', Fosc=32kHz (Crystal type, CLKS="0"), Output pin floating, WDT disabled, LVR disabled	–	15	20	μA
ICC2	Operating supply current at two clocks (VDD=3V)	/RESET= 'High', Fosc=32kHz (Crystal type, CLKS="0"), Output pin floating, WDT enabled, LVR disabled	–	15	25	μA
ICC3	Operating supply current at two clocks (VDD=5V)	/RESET= 'High', Fosc=4MHz (Crystal type, CLKS="0"), Output pin floating, WDT enabled, LVR disabled	–	1.5	1.7	mA
ICC4	Operating supply current at two clocks (VDD=5V)	/RESET= 'High', Fosc=10MHz (Crystal type, CLKS="0"), Output pin floating, WDT enabled, LVR disabled	–	2.8	3.0	mA

Internal RC Electrical Characteristics (Ta=25°C, VDD=5 V, VSS=0V)

Internal RC	Drift Rate				
	Temperature	Voltage	Min.	Typ.	Max.
4MHz	25°C	5V	3.84MHz	4MHz	4.16MHz
16MHz	25°C	5V	15.36MHz	16MHz	16.64MHz
1MHz	25°C	5V	0.96MHz	1MHz	1.04MHz
455kHz	25°C	5V	436.8kHz	455kHz	473.2kHz

Internal RC Electrical Characteristics (Ta=-40 ~85°C, VDD=2.1~5.5 V, VSS=0V)

Internal RC	Drift Rate				
	Temperature	Voltage	Min.	Typ.	Max.
4MHz	-40~85°C	2.1~5.5V	3.44MHz	4MHz	4.56MHz
16MHz	-40~85°C	2.1~5.5V	13.76MHz	16MHz	18.24MHz
1MHz	-40~85°C	2.1~5.5V	0.86MHz	1MHz	1.14MHz
455kHz	-40~85°C	2.1~5.5V	391.3kHz	455kHz	518.7kHz

8.1 Comparator (OP) Characteristic

Vdd = 5.0V, Vss=0V, Ta=25°C

Symbol	Parameter	Condition	Min.	Typ.	Max.	Unit
VOS	Input Offset Voltage	RL = 5.1K Note ¹	–	–	10	mV
Vcm	Input Common-Mode Voltage Range	Note ²	GND	–	VDD-1	V
IOS	Input Offset Current	–	–	–	50	nA
IBS	Input Bias Current	–	–	25	250	nA
ICO	Supply Current of Comparator	–	–	300	–	μA
TRS	Response Time	VREF=1.4V, VRL = 5V, RL = 5.1k, CL=15p, Note ³	0.5	1.3	3.5	μs
TLRS	Large Signal Response Time	VRL = 5V, RL = 5.1k	–	300	–	ns
IOL	Output Sink Current	Vi (-)=1V, Vi (+)=0V, Vo = GND+0.5V	–	12	–	mA
VSAT	Saturation Voltage	Vi (-)=1V, Vi (+)=0V, IOL ≤ 4mA	–	0.2	0.4	V
VS	Operating Range	–	2.5	–	5.5	V

Note: ¹ The output voltage is in the unit gain circuitry and over the full input common-mode range.

² The input common-mode voltage or either input signal voltage should not be allowed to go negative by more than 0.3V. The upper end of the common-mode voltage range is VDD-1.

³ The response time specified is a 100mV input step with 5mV overdrive.

9 AC Electrical Characteristic

Ta=25°C, VDD=5V±5%, VSS=0V

Symbol	Parameter	Conditions	Min	Type	Max	Unit
Dclk	Input CLK Duty Cycle	–	45	50	55	%
Tins	Instruction Cycle Time (CLKS="0")	Crystal type	100	–	DC	ns
		RC type	500	–	DC	ns
Ttcc	TCC Input Time Period	–	(Tins+20) × N*	–	–	ns
Tdrh	Device Reset Hold Time	Ta = 25°C	11.3	16.2	21.6	ms
Trst	/RESET Pulse Width	Ta = 25°C	2000	–	–	ns
Twdt	Watchdog Timer Duration	Ta = 25°C	11.3	16.2	21.6	ms
Tset	Input Pin Setup Time	–	–	0	–	ns
Thold	Input Pin Hold Time	–	15	20	25	ns
Tdelay	Output Pin Delay Time	Cload=20pF	45	50	55	ns
Tdrc	ERC Delay Time	Ta = 25°C	1	3	5	ns

Note: *N = selected prescaler ratio

10 Timing Diagrams

AC Test Input/Output Waveform

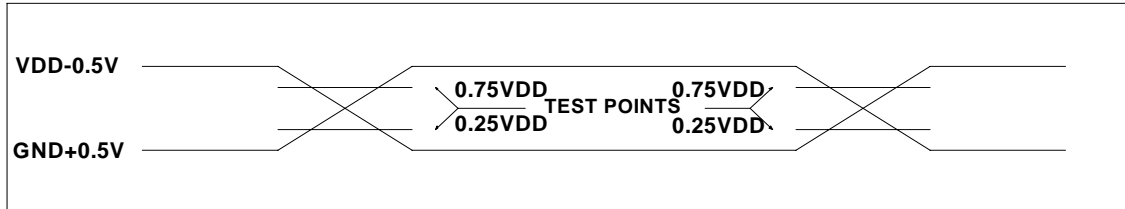

AC Testing : Input is driven at VDD-0.5V for logic "1",and GND+0.5V for logic "0".Timing measurements are made at 0.75VDD for logic "1",and 0.25VDD for logic "0".

RESET Timing (CLK="0")

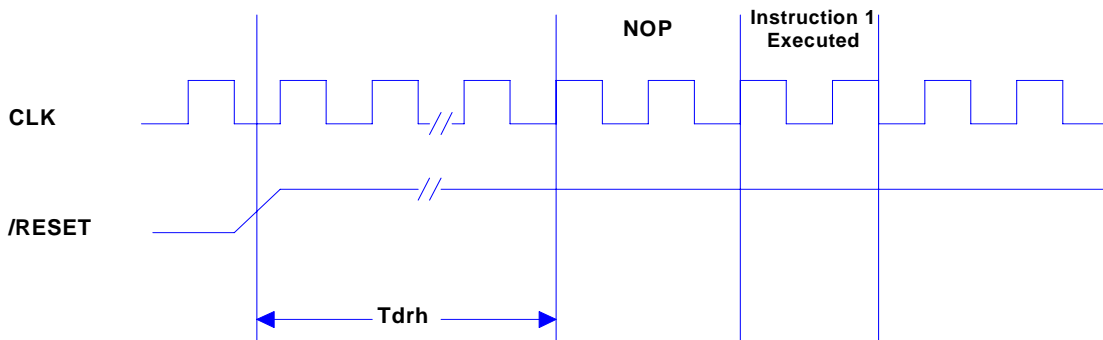

TCC Input Timing (CLKS="0")

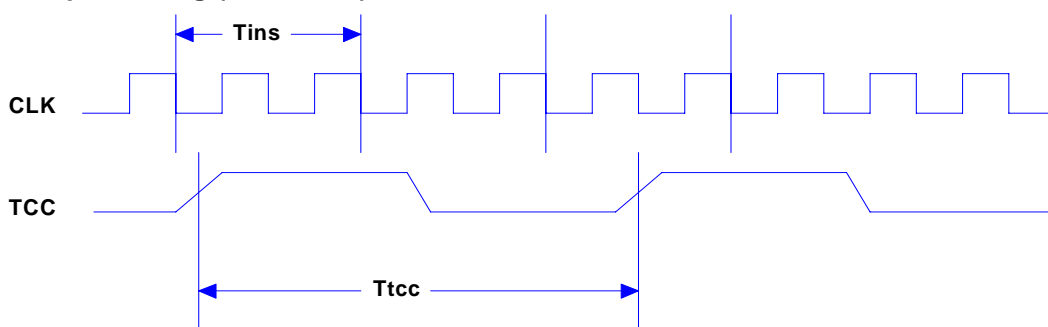

APPENDIX

A Package Type

OTP MCU	Package Type	Pin Count	Package Size
EM78P221NKS/NKJ	Skinny DIP	24 pins	300mil
EM78P221NMS/NMJ	SOP	24 pins	300mil
EM78P221NAMS/NAMJ	SSOP	24 pins	209mil
EM78P222NKS/NKJ	Skinny DIP	28 pins	300mil
EM78P222NMS/NMJ	SOP	28 pins	300mil
EM78P222NAMS/NAMJ	SSOP	28 pins	209mil

Green products do not contain hazardous substances.

The third edition of Sony SS-00259 standard.

Pb contents should be less than 100ppm

Pb contents comply with Sony specs.

Part No.	EM78P221/222/NxS/xJ
Electroplate Type	Pure Tin
Ingredient (%)	Sn: 100%
Melting Point (°C)	232°C
Electrical Resistivity ($\mu\Omega$ -cm)	11.4
Hardness (hv)	8~10
Elongation (%)	>50%

B Packaging Configuration

B.1 24-Lead Plastic Skinny Dual in line (SDIP) — 300 mil

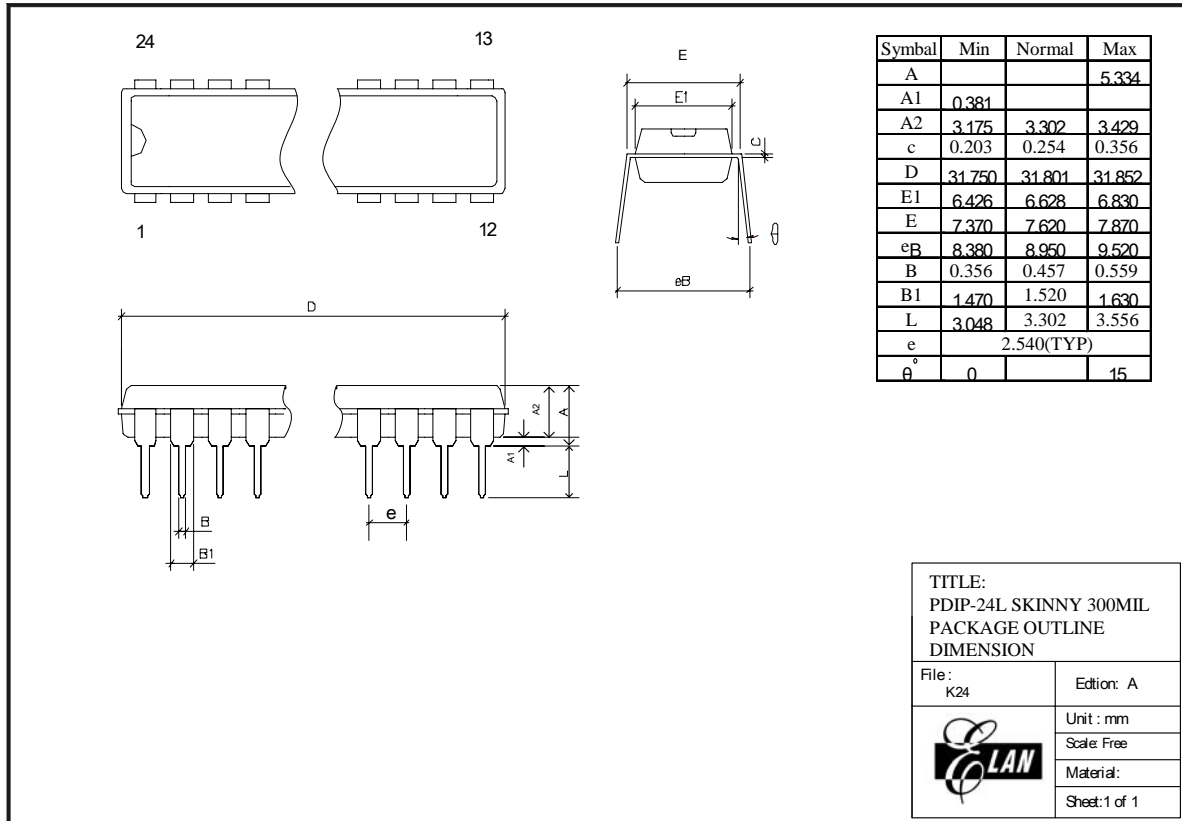

B.2 24-Lead Plastic Small Outline (SOP) — 300 mil

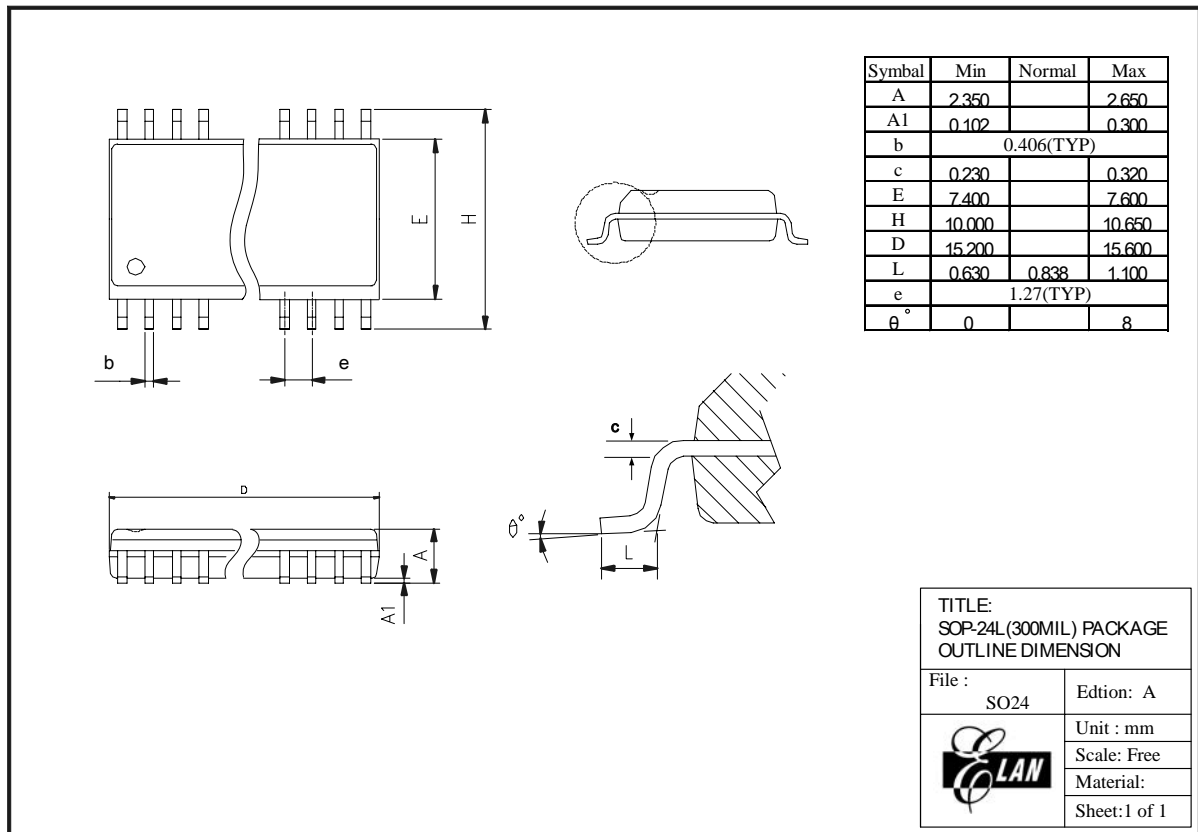

B.3 24-Lead Plastic Shrink Small Outline (SSOP) — 209 mil

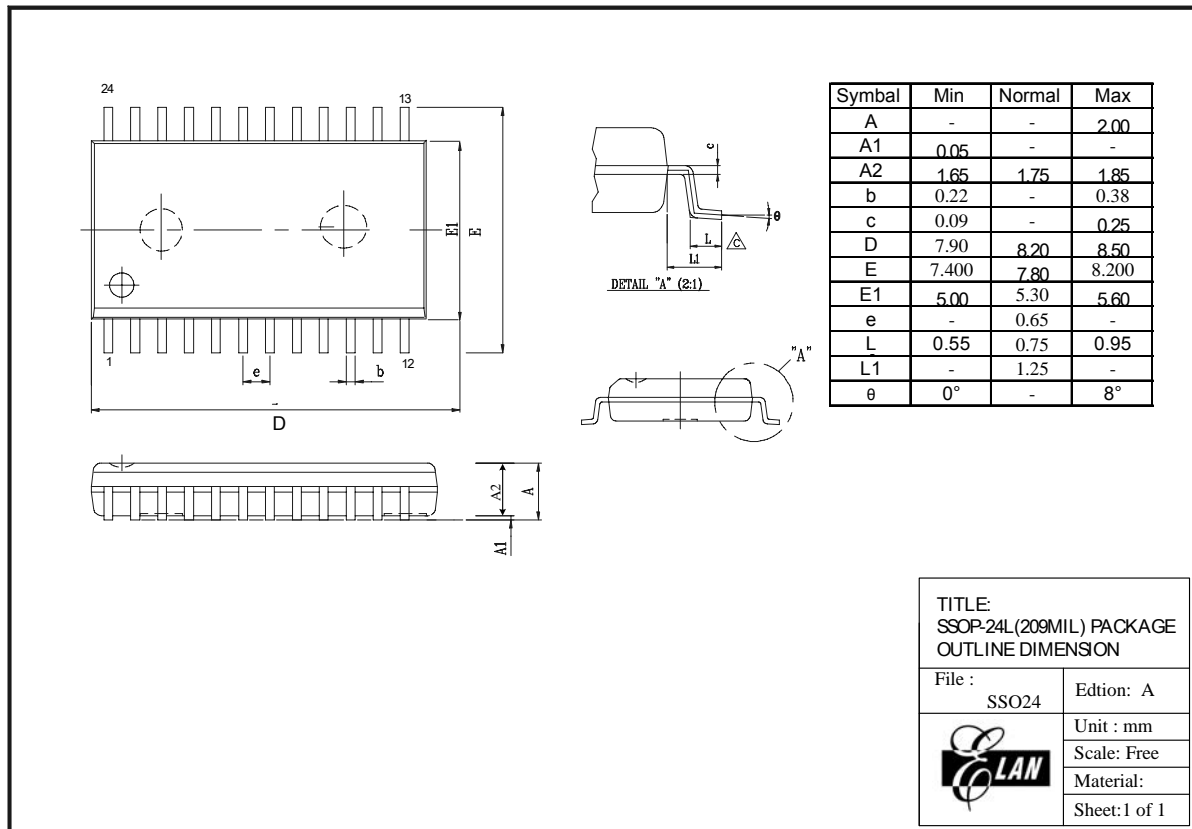

B.4 28- Lead Plastic Skinny Dual in line (SDIP) — 300 mil

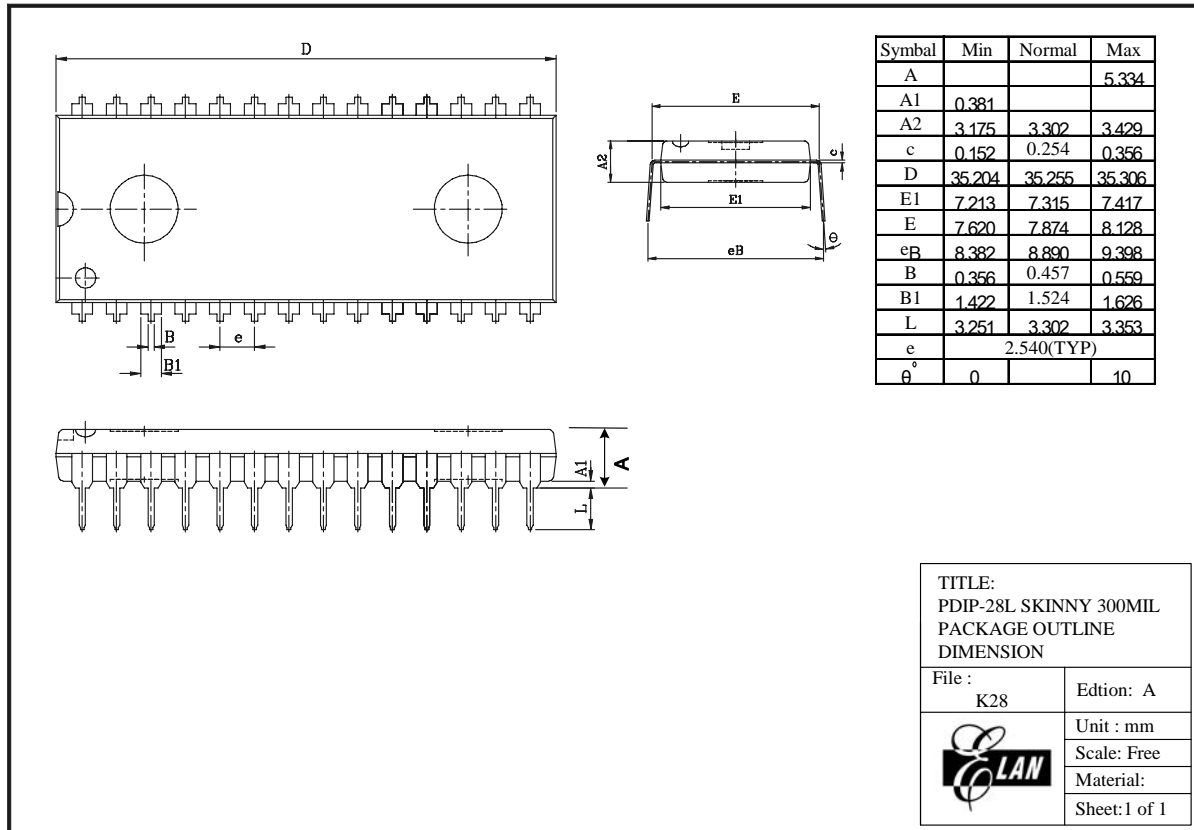

B.5 28-Lead Plastic Small Outline (SOP) — 300 mil

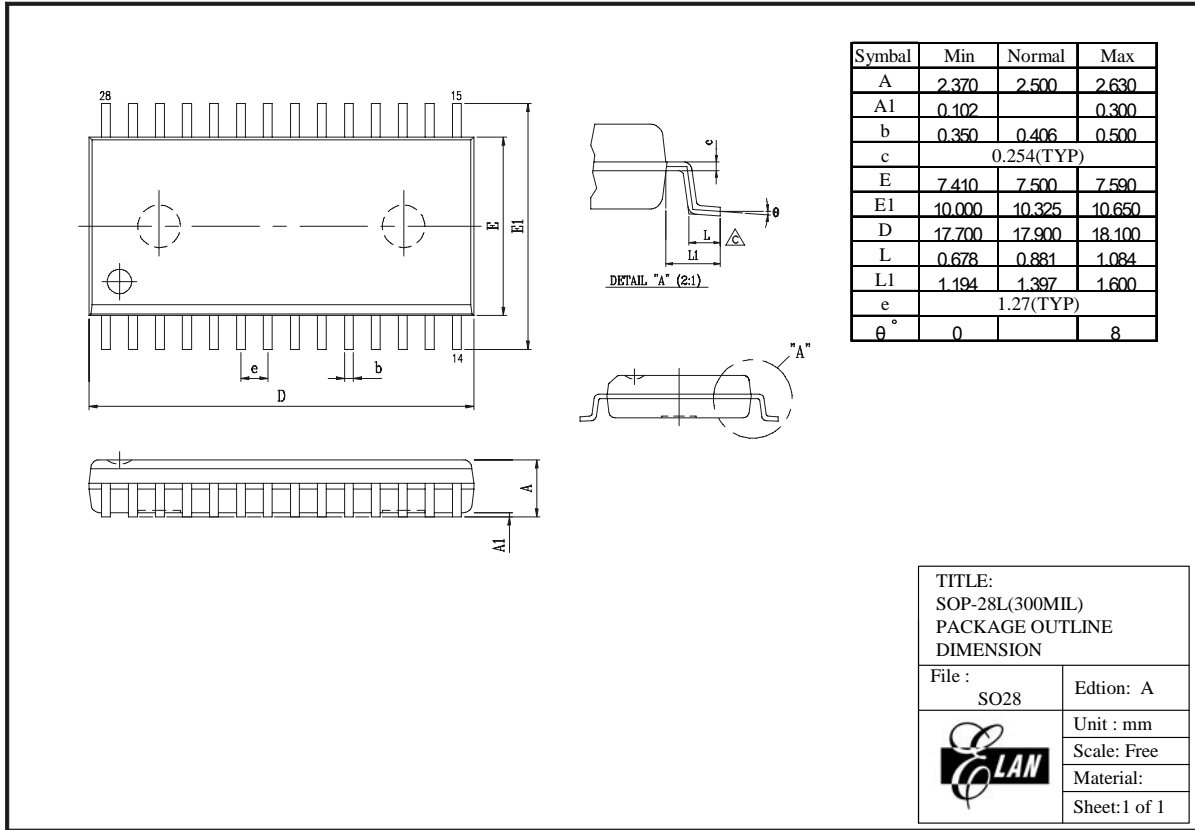

B.6 28- Lead Plastic Shrink Small Outline (SSOP) — 209 mil

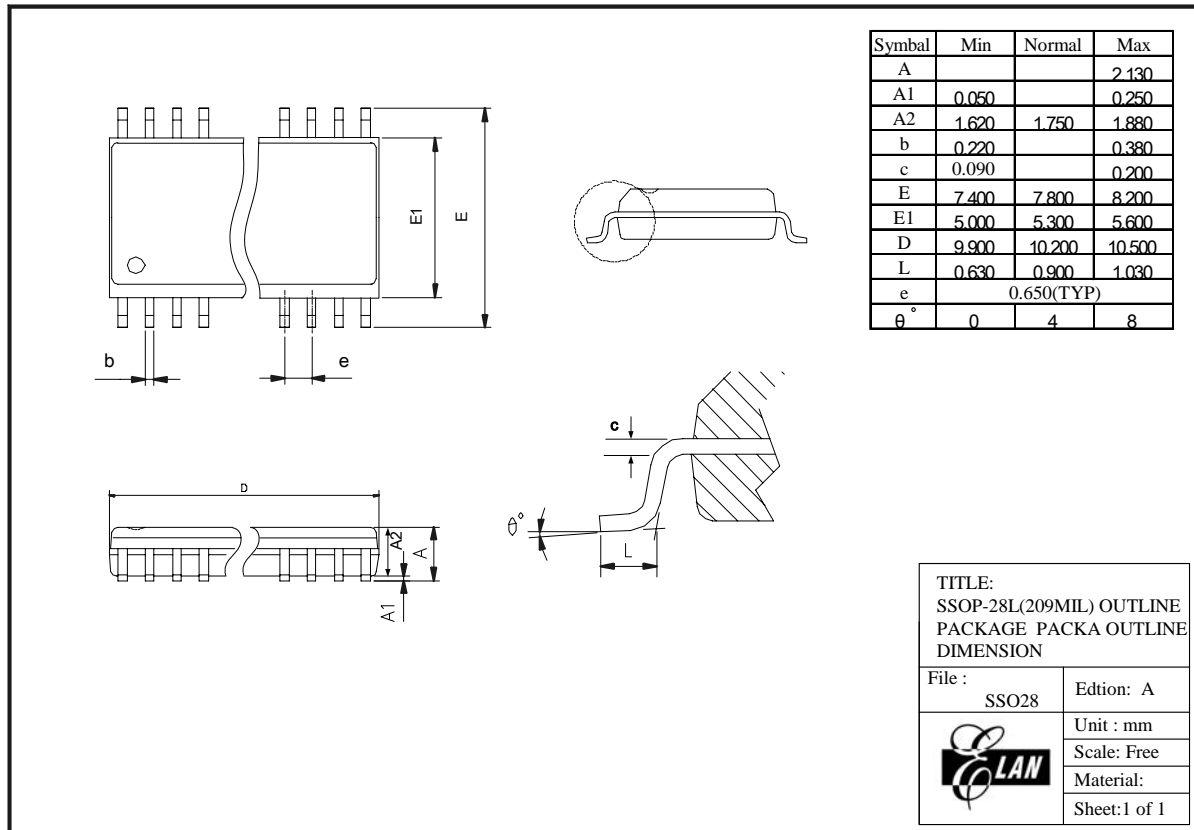

C Quality Assurance and Reliability

Test Category	Test Conditions	Remarks
Solderability	Solder temperature=245±5°C, for 5 seconds up to the stopper using a rosin-type flux	-
Pre-condition	Step 1: TCT, 65°C (15 mins)~150°C (15 mins), 10 cycles	For SMD IC (such as SOP, QFP, SOJ, etc)
	Step 2: Bake at 125°C, TD (endurance)=24 hrs	
	Step 3: Soak at 30°C/60% , TD (endurance)=192 hrs	
	Step 4: IR flow 3 cycles (Pkg thickness: 2.5mm or Pkg volume: 350mm ³ ----225±5°C) (Pkg thickness: 2.5mm or Pkg volume: 350mm ³ ----240±5°C)	
Temperature cycle test	-65°C (15 mins) ~ 150°C (15 mins), 200 cycles	-
Pressure cooker test	TA =121°C, RH=100%, pressure=2 atm, TD (endurance)= 96 hrs	-
High temperature / High humidity test	TA=85°C, RH=85% , TD (endurance)=168, 500 hrs	-
High-temperature storage life	TA=150°C, TD (endurance)=500, 1000 hrs	-
High-temperature operating life	TA=125°C, VCC=Max. Operating Voltage, TD (endurance) =168, 500, 1000 hrs	-
Latch-up	TA=25°C, VCC=Max. operating voltage, 150mA/20V	-
ESD (HBM)	TA=25°C, ± 3KV	IP_ND,OP_ND,IO_ND IP_NS,OP_NS,IO_NS IP_PD,OP_PD,IO_PD, IP_PS,OP_PS,IO_PS,
ESD (MM)	TA=25°C, ± 300V	VDD-VSS(+),VDD_VS S (-) mode

C.1 Address Trap Detect

An address trap detect is one of the MCU embedded fail-safe functions that detects MCU malfunction caused by noise or the like. Whenever the MCU attempts to fetch an instruction from a certain section of ROM, an internal recovery circuit is auto started. If a noise caused address error is detected, the MCU will repeat execution of the program until the noise is eliminated. The MCU will then continue to execute the next program.

Free Manuals Download Website

<http://myh66.com>

<http://usermanuals.us>

<http://www.somanuals.com>

<http://www.4manuals.cc>

<http://www.manual-lib.com>

<http://www.404manual.com>

<http://www.luxmanual.com>

<http://aubethermostatmanual.com>

Golf course search by state

<http://golfingnear.com>

Email search by domain

<http://emailbydomain.com>

Auto manuals search

<http://auto.somanuals.com>

TV manuals search

<http://tv.somanuals.com>