

ZMAXdp
Dual AMD Opteron™ SFF Barebone
User's Manual

Version 1.0
FB246284011

Contents:

FCC Compliance Statement	4
Disclaimer, Trademarks and Copyright	5
Welcome	6
About this manual	7
About this guide	8
Unpacking	9
Chapter 1. System Introduction	10
Front Panel Features	11
Rear Panel Features	12
Internal Features	13
Chapter 2. Assembling the System	14
Removing the cover.....	15
Removing the drive holder	18
Installing the processor	23
Installing the heatsink	24
Installing system memory	25
Installing an AGP card	27
Installing HDDs	28
Installing a optical drive.....	29
Chapter 3. Positioning the System unit	31
Connecting with a monitor	32
Connecting the keyboard and mouse.....	32
Connecting the Ethernet cable.....	33
Connecting the printer.....	33
Connecting the scanner.....	34
Connecting the power cord.....	34
Connecting the USB/ IEEE1394 peripherals.....	35
Connecting the speakers.....	36
Arranging your workspace.....	37

Chapter 4. Mainboard Information	39
Introduction.....	40
Motherboard photos.....	41
Motherboard layout.....	43
Central processing unit and System memory.....	46
Expansion slot	48
Jumpers Setting	50
Internal Connectors.....	51
Chapter 5. BIOS Setup	53
Updating your BIOS.....	54
Using AMIFLASH.EXE to update the BIOS.....	55
BIOS setup program.....	56
Using the BIOS Setup Utility.....	57
Main Menu.....	59
Advanced Menu.....	60
IDE Configuration Submenu.....	62
PCI PnP.....	63
Boot Configurations.....	65
BIOS Security Menu.....	67
BIOS Chipset Configurations.....	69
North Bridge Chipset Configuration Sub-Menu.....	70
South Bridge Chipset Configuration Sub-Menu.....	72
BIOS Exit Menu.....	74
Chapter 6. Drivers and Utilities	75
Drivers and Utilities, Software.....	76
Chapter 7. Specification	79

Federal Communications Commission (FCC) statement

This equipment has been tested and found to comply with limits for a Class B digital device, pursuant to Part 15 of the FCC rules. These limits are designed to provide reasonable protection against harmful interference in residential installations. This equipment generates, uses, and can radiate radio frequency energy, and if not installed and used in accordance with the instructions, may cause harmful interference to radio communications.

However, there is no guarantee that interference will not occur in a particular installation. If this equipment does cause interference to radio or television equipment reception, which can be determined by turning the equipment off and on, the user is encouraged to try to correct the interference by one or more of the following measures:

- Reorient or relocate the receiving antenna
- Move the equipment away from the receiver
- Plug the equipment into an outlet on a circuit different from that to which the receiver is connected
- Consult an experienced radio/television technician for additional suggestions

This device complies with Part 15 of the FCC Rules. Operation is subjected to the following two conditions 1) this device may not cause harmful interference and 2) this device must accept any interference received, including interference that may cause undesired operation.

 Tested To Comply
With FCC Standards
FOR HOME OR OFFICE USE

Disclaimer

The information in this document is subject to change without notice. The manufacturer makes no representations or warranties regarding the contents of this manual and specifically disclaims any implied warranties of merchantability or fitness for any particular purpose. Furthermore, the manufacturer reserves the right to revise this publication or make changes in the specifications of the product described within it at any time without notice and without obligation to notify any person of such revision.

Trademarks

Microsoft® and Windows® are registered trademarks of Microsoft® Corp. nVIDIA® and nFORCE® are registered of nVIDIA® Corporation. AMD® and AMD Opteron™ are registered trademarks of AMD® Corporation. Other product names used in this manual are the properties of their respective owners and are acknowledged.

Copyright

This publication, including all photographs, illustrations and software, is protected under international copyright laws, with all rights reserved. Neither this manual, nor any of the material contained herein, may be reproduced without the express written consent of the manufacturer. IWILL ©Copyright 2003

Welcome

Thank you for buying the IWILL® ZMAXdp barebone! The barebone delivers a host of new features and latest technologies making it another standout in the long line of IWILL quality motherboards!

The barebone combines the powers of the AMD Opteron™ processor and the NVIDIA® nForce3 Pro250 chipset to set a new benchmark for an effective desktop platform solution. Supporting up to 2GB of system memory with PC3200/PC2700/PC2100 registered DDR SDRAM, 300W Power supply, high-performance graphics via an AGP 8X slot, SATA, IEEE1394, USB 2.0, and 6-channel audio features, the barebone takes you ahead in the world of power computing! Before you start installing the motherboard, and hardware devices on it, check the items in your package with the list below.

The system has good thermal solution. The specially designed CPU cooler supports CPU up to Model 250 (2.4GHz) and Model 240EE (Low-Power, 30W). The system fans also effectively help to exhaust hot air through a complete air flow direction. Built with silicon-on-insulator transistors and copper interconnects. To dissipate the heat it does produce, two big and low speed fans draw air from the bottom of the machine, across the storage, processor, power supply and out the back. It keeps your system stable and quiet.

With the user's guide's step-by-step instructions, chassis installation can never be easier. Read this manual, which provides updates and supplemental information about your computer.

About this Manual

Audience

This guide provides general information and installation instructions about the IWILL ZMAXdp series Barebone workstation. This guide is intended for experienced users and integrators with hardware knowledge of personal computers.

How this guide is organized

This document contains the following parts:

1. Chapter 1: System Introduction
This chapter gives a general description of the IWILL barebone system. It includes introduction on the front and rear panel features, and the internal features.
2. Chapter 2: System Assembly
This chapter tells how to install components into the barebone system through illustrated step-by-step instructions.
3. Chapter 3: Positioning the System Unit
This chapter detail steps of setting up your computer, arranging your workspace and installing other peripherals.
4. Chapter 4: Motherboard Information
This chapter gives information about the P4S8L motherboard that came with the system. This chapter includes the motherboard layout, jumper settings, and connector locations. It also includes information on the USB/audio board located on the front panel.
5. Chapter 5: BIOS information
This chapter tells how to change system settings through the BIOS Setup menus. It includes detailed descriptions of the BIOS parameters.
6. Chapter 6: Drivers and Utilities
This chapter helps you power up your system and install drivers and utilities that came with the support CD.
7. Chapter 7: Specification
This chapter gives information about ZMAXdp detail hardware specification.

About this guide

Illustrations used in this guide

**WARNING!**

Information to prevent injury to yourself when trying to complete a task.

**DANGER!**

Information to prevent damage to the components.

**IMPORTANT**

Information that you **MUST** follow to complete a task.

**NOTE**

Tips and additional information to aid in completing a task.

Where to find more information

Refer to the IWILL Websites for additional information and for product and software updates.

Unpacking ZMAXdp

Your ZMAXdp may not be supplied with all of the accessories shown, depending on the system configuration you purchased. For details on the accessories supplied with your computer, see the specifications sheet in this manual.



ZMAXdp barebone unit



Power Cord



IDE Device power cable



Screws and thermal cream



SATA ribbon cable



SATA devices power cable



User's Manual



User's Manual



Wireless LAN antenna (Note)



Wireless LAN cable (Note)



Wireless LAN card (Note)



Wireless LAN antenna has been assembled in the ZMAXdp already.



Note: Wireless LAN module (Including antenna, cable and Wireless LAN card) has been assembled in the ZMAX-AP already.

Chapter 1

All about the IWILL ZMAXdp series barebone system: the front and rear panel features, and the internal layout and design.

The IWILL ZMAX series barebone system includes the IWILL motherboard, a power supply, accessories and cables built into in a chassis

This section shows the various external connectors on your computer to which you can attach external options, such as external speakers, a printer, or a scanner. For some external options, you must install additional software in addition to making the physical connection. When adding an external option, use the information in this section to identify the required connector, and then use the instructions that come with the option to help you make the connection and install any software or device drivers that are required for the option.

System Introduction

ZMAXdp Front Panel Features:

The front panel of ZMAXdp features: a 5.25" empty bay, 6-in-1 card reader, two 6-pin Firewire jacks, and two USB2.0 connectors

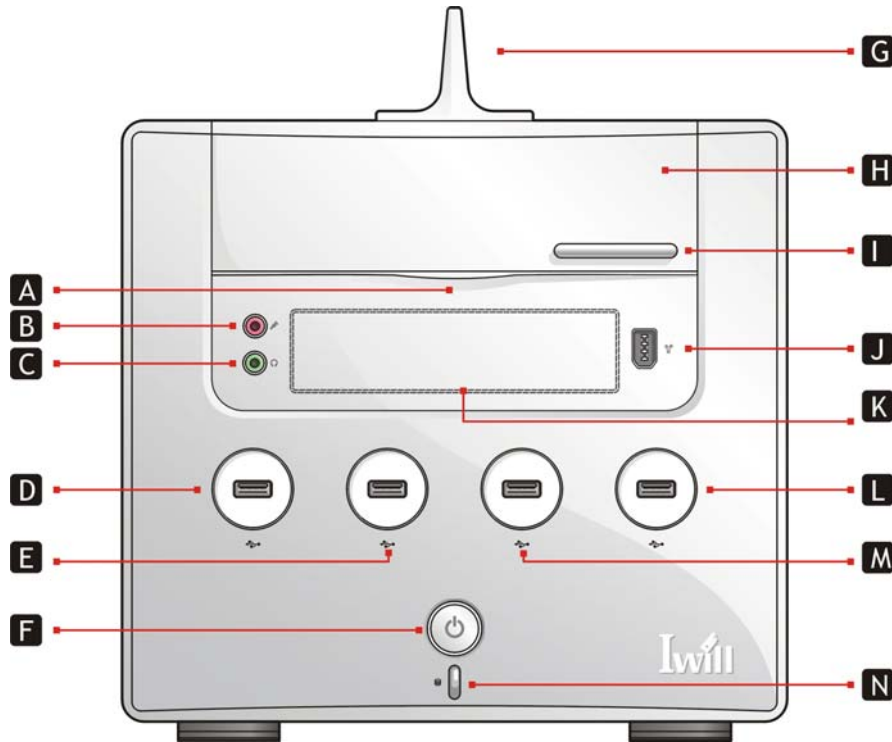

A	Open	H	Empty Bay For Optical Drive
B	Microphone	I	Optical Drive Eject Button
C	Earphone	J	IEEE1394 (Firewire)
D	USB2.0 Port	K	Empty 3.5" FDD or Card Reader
E	USB2.0 Port	L	USB2.0 Port
F	Power On Button	M	USB2.0 Port
G	WLAN Antenna (WLAN Version Only)	N	Power On Indicator

ZMAXdp Rear Panel Features:

The back panel of your ZMAXdp contains the ports for supplied and optional accessories. The icons on the back panel locate and identify the ports on your computer.

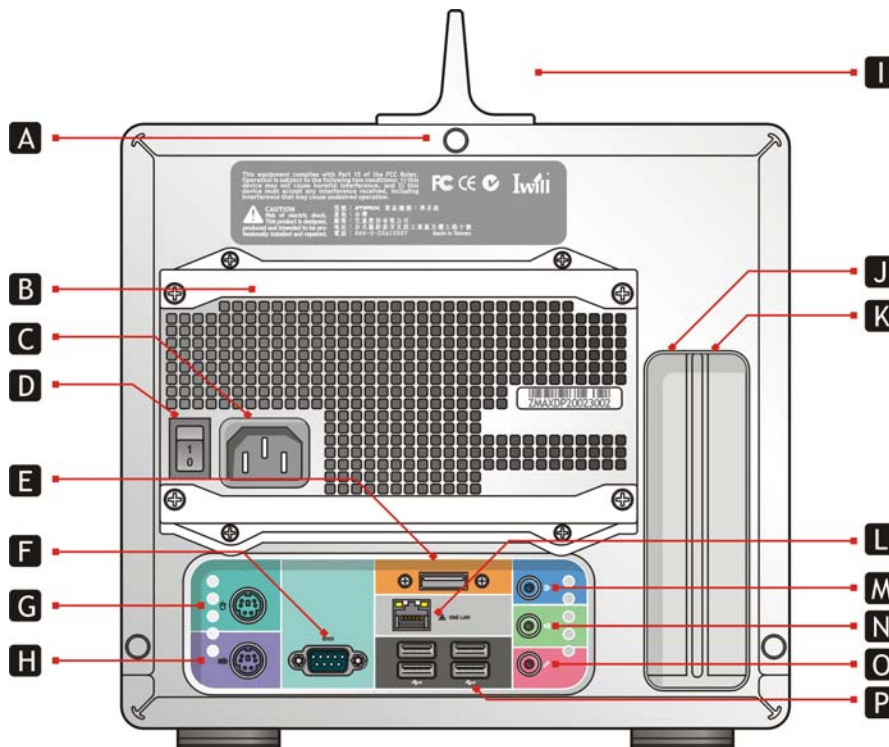

A	Screws on rear	I	WLAN Antenna (WLAN Version Only)
B	Power supply	J	Empty AGP slot
C	AC Input port	K	Empty PCI slot
D	Power supply switch	L	Ethernet
E	External SATA	M	Line in
F	Serial port	N	Line out
G	PS/2 mouse port	O	Microphone
H	PS/2 keyboard	P	USB 2.0 ports

Internal Features

The figure below shows the system from side. The standard components (Motherboard, Heatsink for processors, power supply...) are already installed.



Actual products may look different from the photo.

Chapter 2

Step-by-step instructions on how to install basic components.

This section outlines how to install and configure your ZMAXdp. Refer to the following mainboard layout to help you to identify various jumpers, connectors, slots, and ports. Then follow these steps designed to guide you through a quick and correct Installation of your system.

IWILL has designed the ZMAXdp for an IWILL motherboard only. It is not advisable to install other motherboards.



Always turn the power off before you open the system or connect your computer to peripheral equipment. Otherwise, damage may occur to the integrated circuits in your computer.



Electrostatic discharge (ESD) may damage HDDs and other components. Follow the procedures described here only at an ESD workstation. Ground yourself by maintaining continuous contact with an unpainted metal portion of the chassis while installation.

Removing the cover

1. Disconnect all cables attached to the computer. This includes power cords, input/output (I/O) cables, and any other cables that are connected to the computer.
2. Remove the WLAN antenna on the top of the computer
3. Release the three screws at the rear of the left side cover
4. Separate the case and chassis cover: use your thumbs to pull it off, from the front to the back, then lift it off the chassis.



Remove the antenna

Pull up the WLAN antenna and remove it from the top of the computer.



Release three screws

Release the three screws on each end of the back panel. This frees the chassis cover. Set the screws aside.



Disconnect the computer from its power source and from telecommunications links, networks, or modems before you open the unit or follow any procedures described in this section.

**Lifting the casing cover**

Separate the case and chassis cover: use your thumbs to pull it off, from the front to the back, then lift it off the chassis.



If you remove the side panel immediately after you shut down your computer, the components may be too hot to touch. Wait until the internal parts of the system unit cool down before you attempt to remove the side panel.

Turn over the drive holder

Release the screws from the CDROM/ HDD rack with a screw driver.



Release the screws from the rack

Release the two screws holding the rack to the casing. Set one screws aside..



Remove this screw

Remove another screw holding the rack to the casing and set it aside.

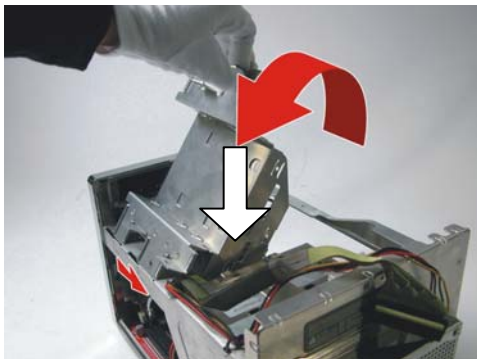

Pull drive holder up

Draw the drive holder a little bit. Pull up the holder, fix the rack on the casing and make it steady.

Remove the drive holder



Please remove the drive holder entirely. It would be easier to install graphic card, CPUs and memory.

Release the screws from the CDROM/ HDD rack with a screw driver.



Release the screw from the rack

Release the two screws holding the rack to the casing. Set one screws aside..

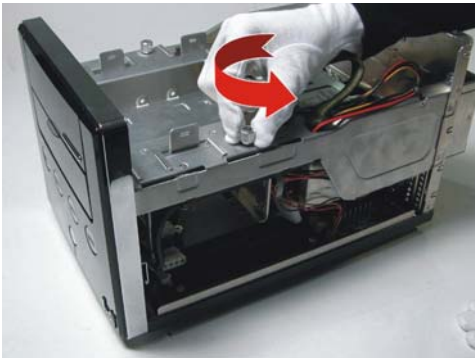

Remove this screw

Remove another screw holding the rack to the casing and set it aside.

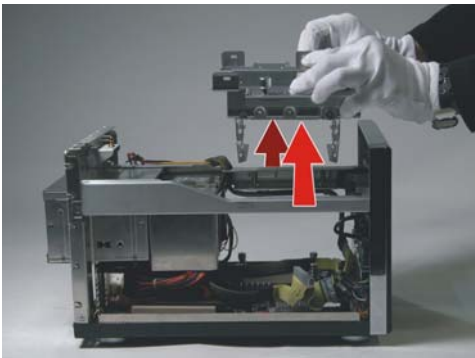

Remove the drive holder

You can remove the drive holder entirely for easy install AGP, CPU and system memory.

Remove the pre-installed heatsink assembly

To install the CPU, it is necessary to remove the pre-installed heatsink module. Please remove six screws from heatsink. Gently handle the heatsink module. Avoid hitting, falling or throwing down the heatsink.

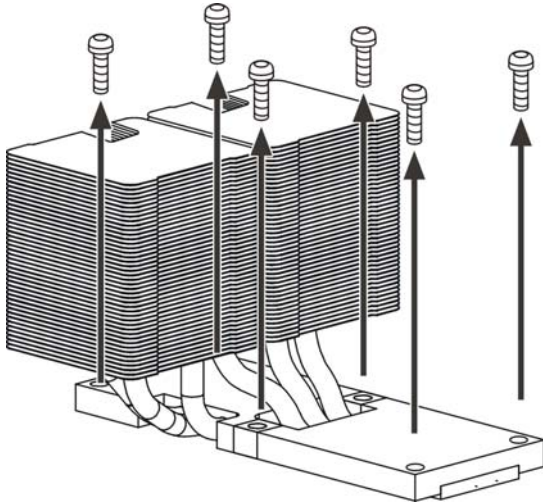

Remove the screws (marked in circles)

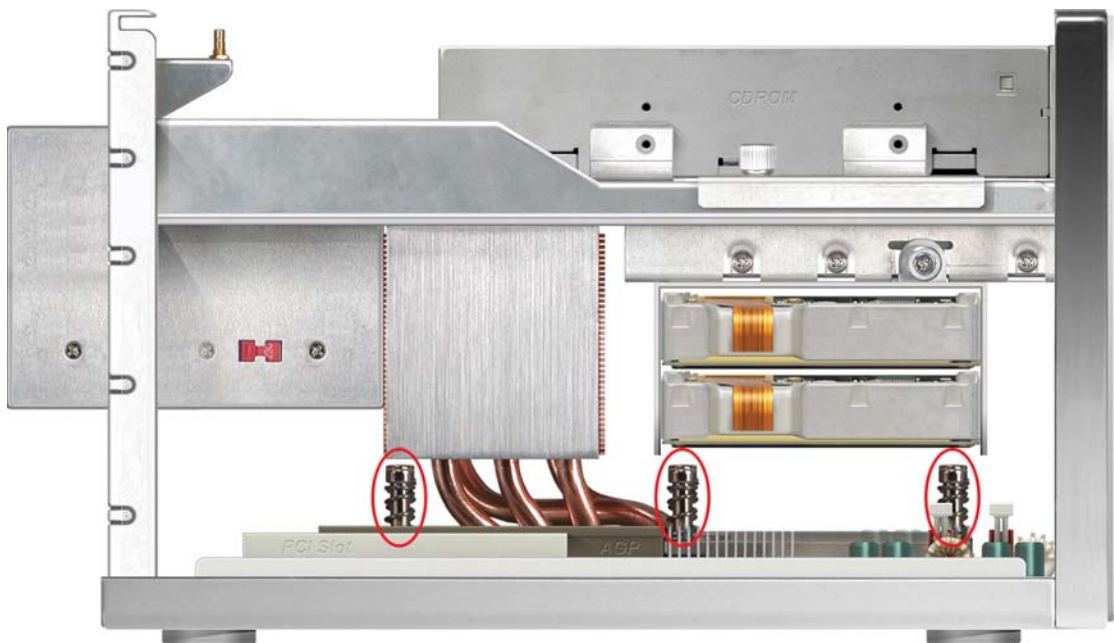

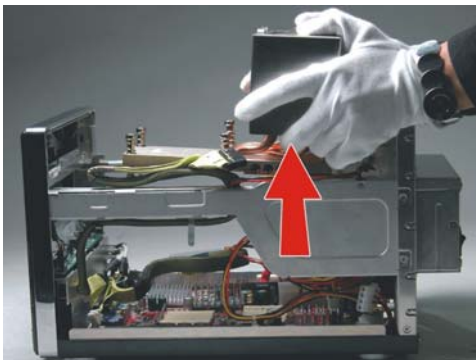

Release the first heatsink entirely

Remove the heatsink, and set it aside. Gently handle the heatsink module. Avoid hitting, falling or throwing down the heatsink.

Central Processing Unit (CPU) Overview

The motherboard comes with a surface mount two 940-pin Zero Insertion Force (ZIF) socket designed for the AMD Opteron™ processors.

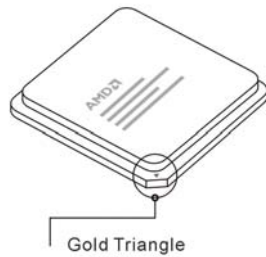

Gold Triangle on the CPU

Take note of the marked corner (with gold triangle) on the CPU. This mark should match a specific corner on the socket to ensure correct installation.

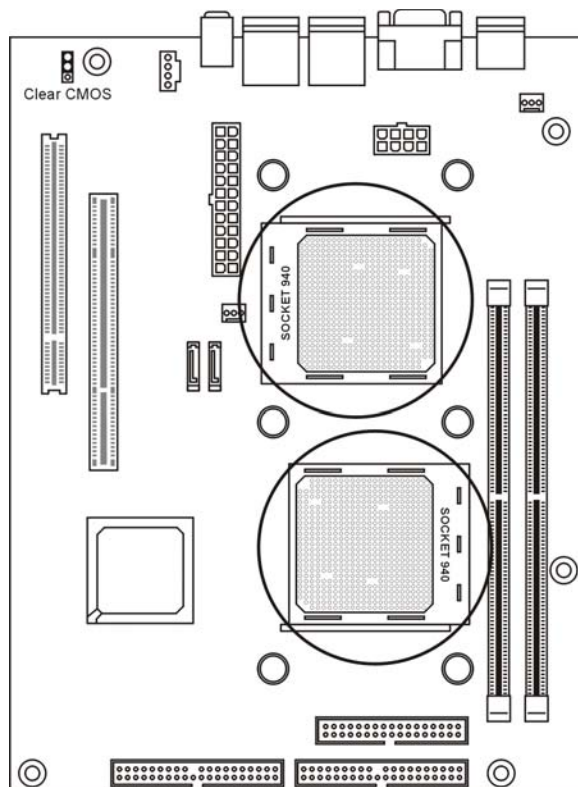

940-pin ZIF socket

Locate the two 940-pin ZIF socket on the motherboard.



The CPU fits only in one correct orientation. DO NOT force the CPU into the socket to prevent bending the pins and damaging the CPU!

Installing the Processor

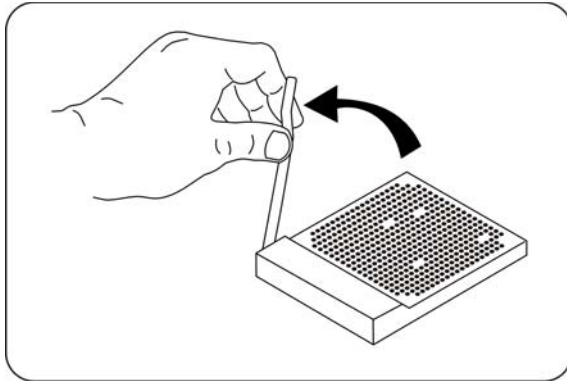

Lever Raised, Unlock the socket

Unlock the socket by pressing the lever sideways, then lift it up to a vertical angle.

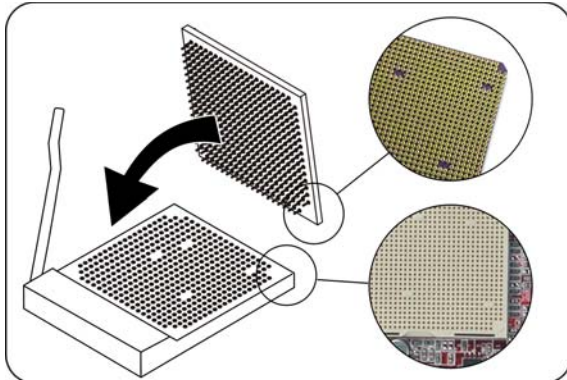

Position the CPU

Position the CPU above the socket such that its marked corner matches the base of the socket lever.

Gently push down on the processor.

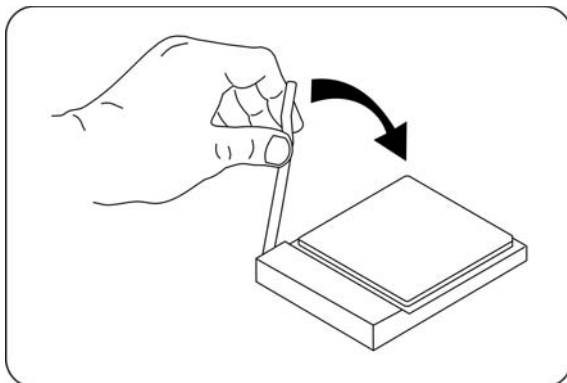

Lowering the locking lever

Press it firmly on the socket while you push down the socket lever to secure the CPU.



Warning: Do not apply voltage until the heatsink is fully installed. If not, the processor will overheat and failure will result.

Place the heatsink on the processor

Never power on unless the heatsink is properly and firmly attached.

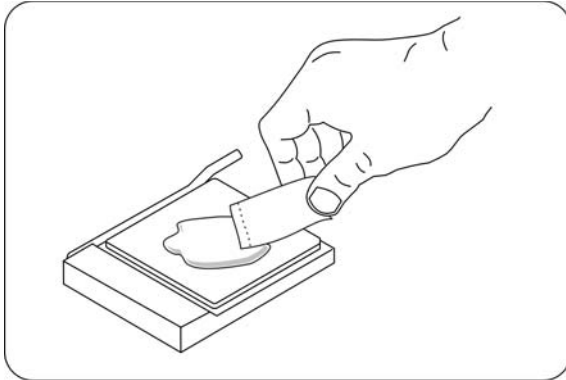

Apply the Thermal cream

After installing the CPU you need to apply the Thermal cream to the top of the installed CPU.

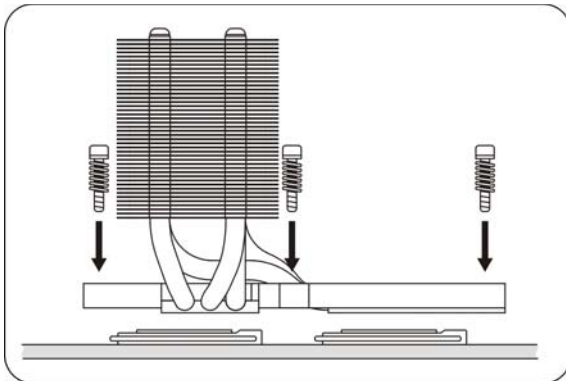

Position the CPU

Position the CPU above the socket such that its marked corner matches the base of the socket lever.

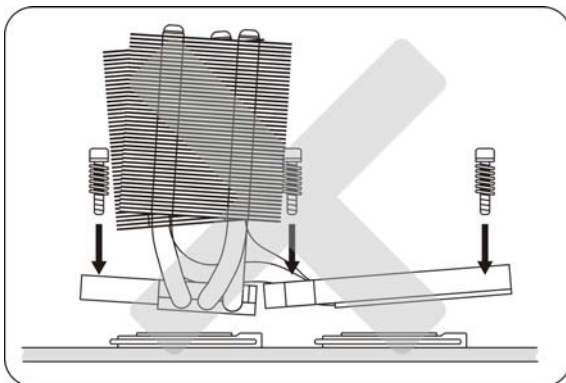

WRONG WAY to Install the Heatsink

This illustration shows the WRONG way to install the heatsink. Do not tilt the heatsink because doing so heatsink will not be properly and firmly attached.



Warning: Do not apply voltage until the heatsink is fully installed. If not, the processor will overheat and failure will result.

Installing the heatsink and tighten the screws

Place the screws and tighten down the heatsink. Do not over-tighten the screws. Ensure that the retention heatsink bases are flat with the motherboard.

Secure the each screw one by one and follow the number sequence shown as the illustrator.

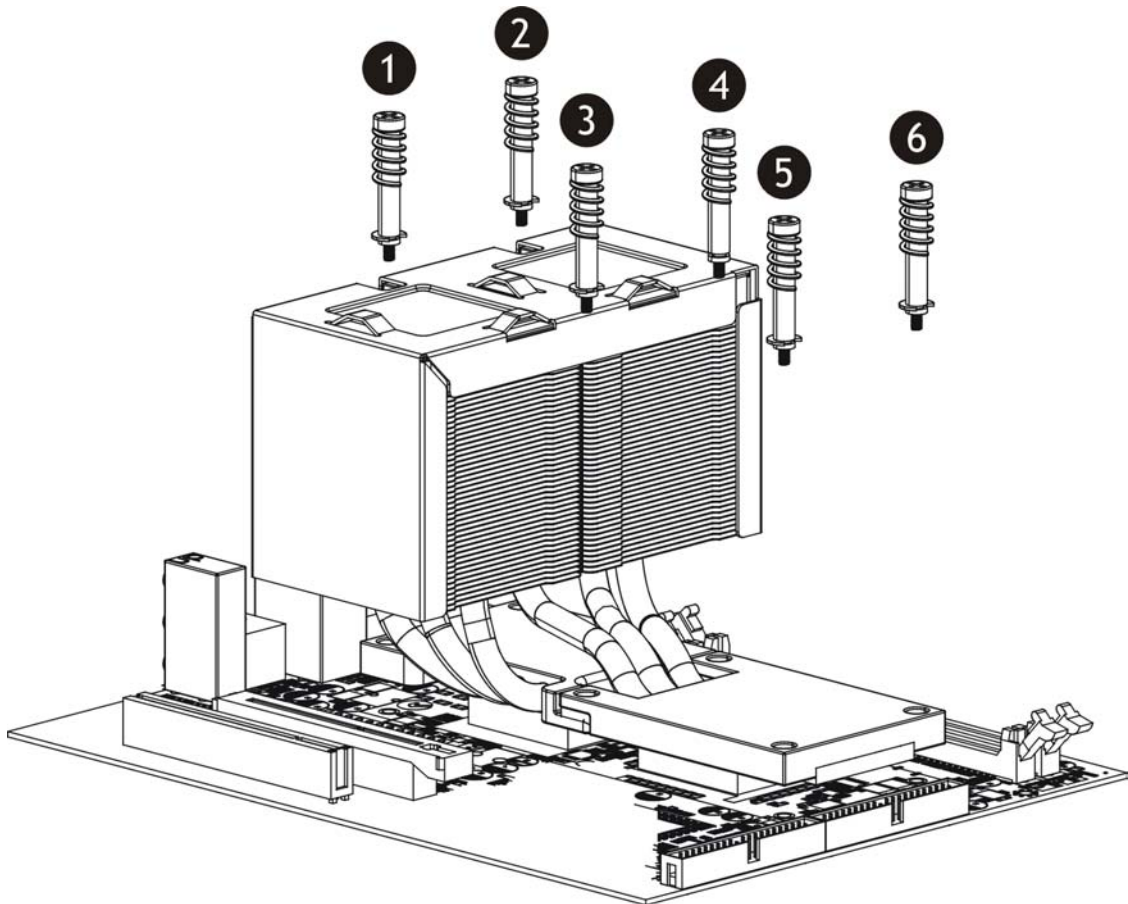

Note: The bottom of the heatsink is parallel with the motherboard. This is the only proper way to install the heatsink.

Installing system memory

The barebone comes with four Double Data Rate (DDR) Dual Inline Memory Module (DIMM) sockets. The following figure illustrates the location of the sockets.

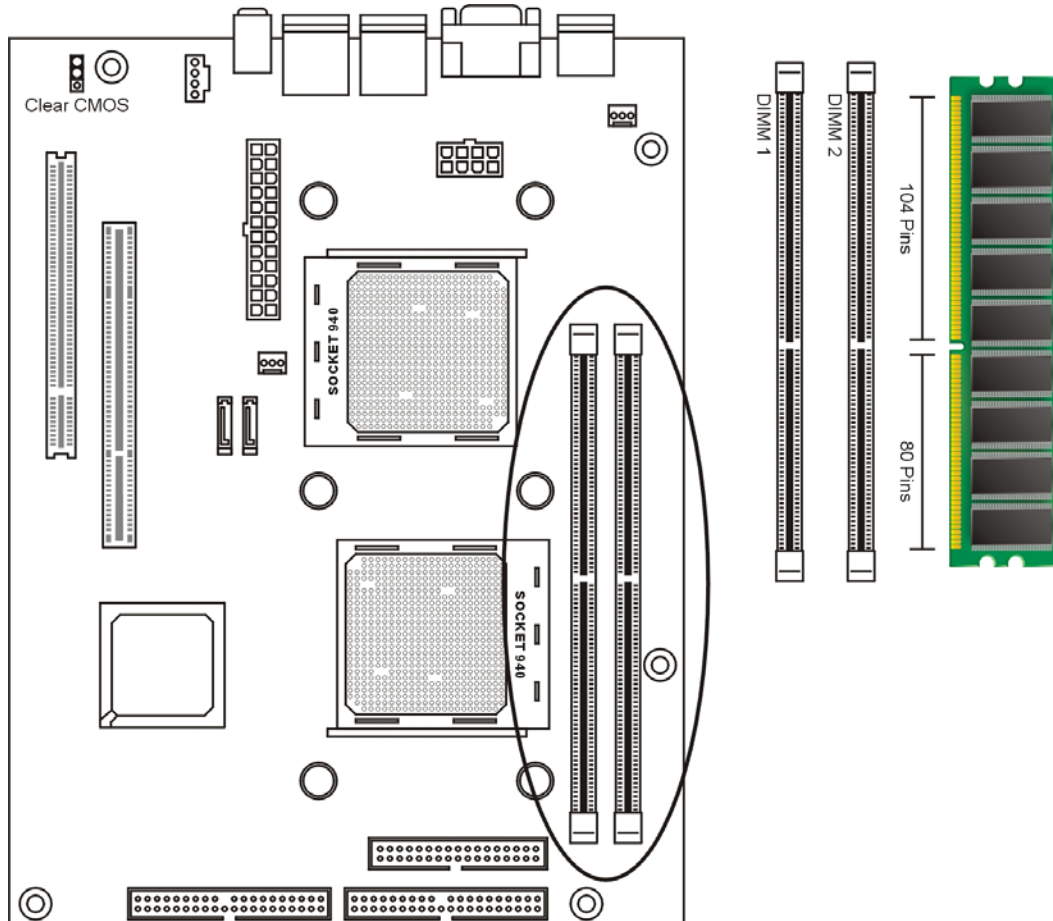

Memory configurations

You may install 64MB, 128MB, 256MB, 512MB, 1GB registered DDR DIMMs into the DIMM sockets using the memory configurations in this section.

Important notes on memory configurations

1. Always install DIMMs with the same CAS latency. For optimum compatibility, it is recommended that you obtain memory modules from the same vendor. See list of Qualified Vendors List on IWILL webpage.
2. It is recommended to install all the DIMM slots with memory for better performance.

Installing a DIMM

Make sure to unplug the power supply before adding or removing DIMMs or other system components. Failure to do so may cause severe damage to both the motherboard and the components.

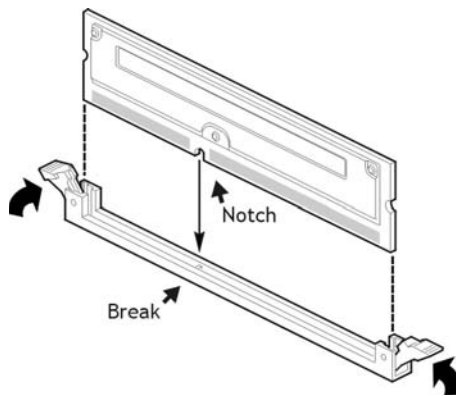

Installing Memory Modules

- Unlock a DIMM socket by pressing the retaining clips outward.
- Align the "notch" on the memory module to the "break" on the socket.
- Firmly insert the module into the socket until the retaining clips snap back into place and the module is properly seated.
- Make sure the memory module is locked on the socket with both retaining clips.



To avoid damaging a memory module slot, move the end latches slightly outward to relieve pressure.



The BIOS recognizes the installed memory and configures the CMOS Setup Utility automatically.



A DDR DIMM is keyed with a notch so that it fits in only one direction. DO NOT force a DIMM into a socket to avoid damaging the DIMM.

Installing an AGP card

Accelerated Graphics Port (AGP) slot that supports AGP8X/4X cards. When you buy an AGP card, make sure that you ask for one with +1.5V specification.



Put the AGP card directly over the proper slot and press one end of the card into the slot. Firmly press the other end until it is fully seated in the slot.

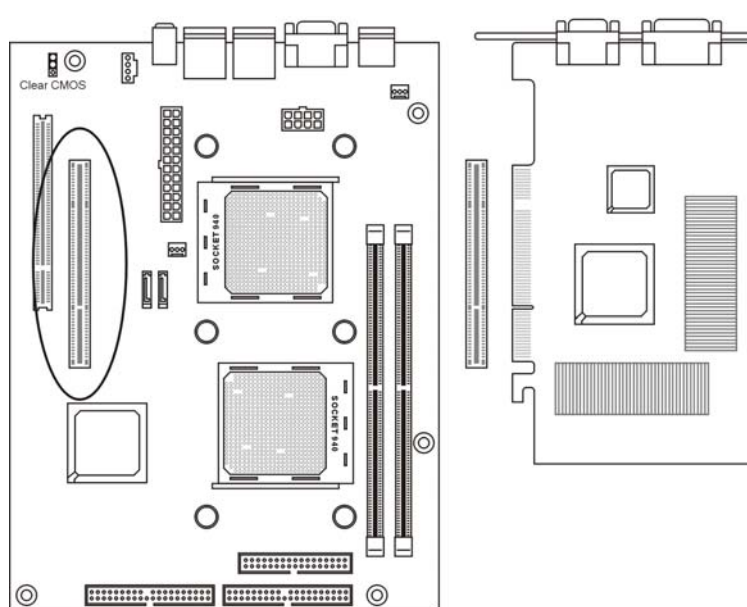

Note the notches on the card golden fingers to ensure that they fit the AGP slot on your ZMAXdp.



Install only 1.5V AGP cards on this motherboard! 3.3V AGP cards are not supported in this motherboard.

Installing hard disk drives

ZMAX comes with two available internal bay to hold two standard 3.5-inch hard disk drive. Your system can support ATA-33, ATA-66, or ATA-100 hard disk drives. IWILL recommends using an ATA-100 hard disk drive to take full advantage of your system's features.



Slip the HDDs into the bay

Carefully slip the HDDs into the disk drive bay. Your new hard disk drive is supplied with the necessary screws.



Attaching the drive screws

Ensure that the four screw holes are properly aligned. Tighten in the screws. Do not over-tighten these screws when securing the drive to the drive holder.



Connect the cables

Connect the IDE cable and power cable to the hard disk drive.

Installing a optical drive

ZMAX comes with one available internal bay to hold a standard 5.25-inch optical drive. Your system can support IDE CDROM/ DVD/ DVD+-RW drives. Follow these steps to install a CD/DVD-ROM drive.



Slip the CDROM/ DVD into the bay

Carefully slip the optical drive into the CDROM bay. Your new CDROM drive is supplied with the necessary screws.



Attaching the drive screws

Ensure that the four screw holes are properly aligned. Tighten in the screws. Do not over-tighten these screws when securing the drive to the drive holder.



Connect the cables

Connect the both data and power cable to the optical drive. Connect the Line-Out cable to motherboard.

Chapter 3

The small form factor design of the IWILL barebone system help to maximize work space and compliments your interior design.

This chapter contains:

1. Positioning the System Unit
2. Setting Up Your Computer
3. Arranging your workspace

Positioning the System Unit

Positioning the System Unit

The small form factor system is placed on a flat stable surface, like an office desk or computer table.



Setting Up Your Computer

Connecting a Display (Monitor)

- Plug the display's cable into the monitor port from the VGA card (which been installed).

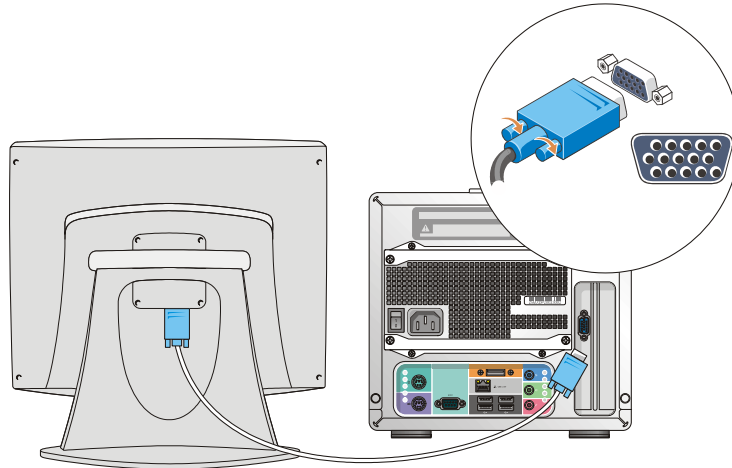

Connecting the Keyboard and Mouse

- Plug the keyboard cable into the keyboard port on the back of the computer.
- Plug the mouse cable into the mouse port on the back of the computer.

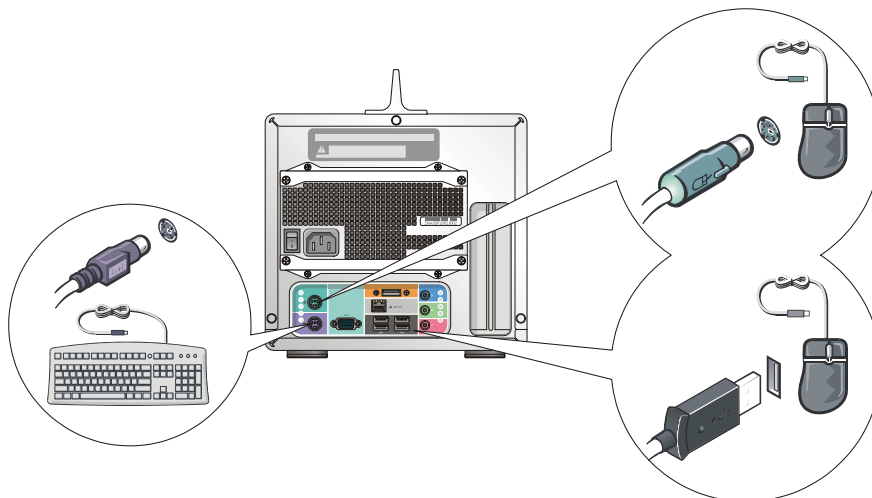

Connecting the Ethernet cable

- Plug the LAN cable into the LAN jack, located on the back panel of your computer.
- Plug the other end of the LAN cable into the wall jack.

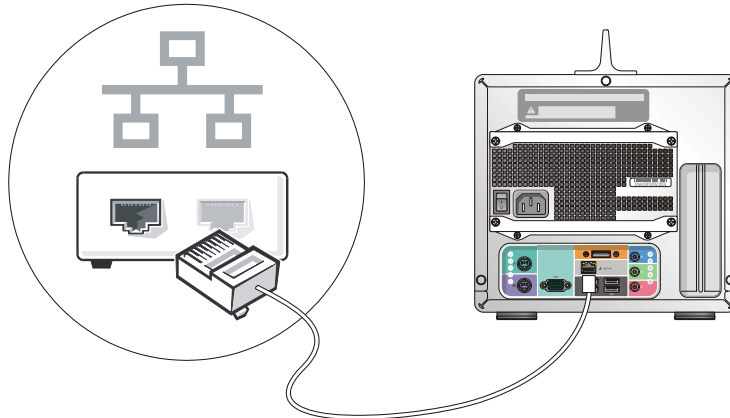

Connecting the printer

- Plug the USB cord into the back of the computer.
- Plug both the USB to printer and printer's power cords into a grounded AC wall outlet

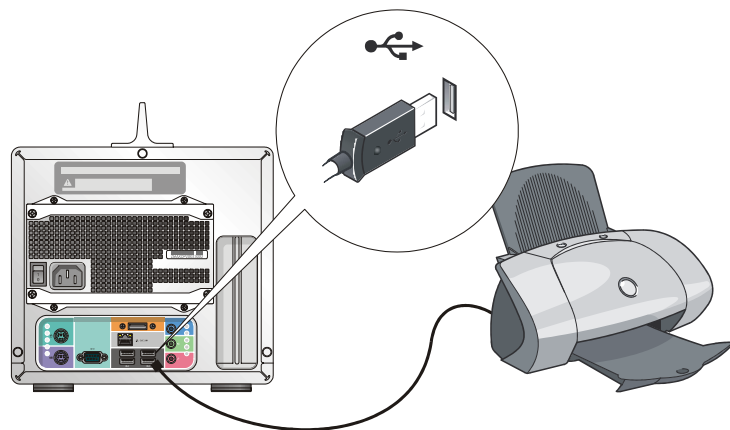

Connecting the Scanner

- Plug the USB cord into the back of the computer.
- Plug both the USB to scanner and scanner's power cords into a grounded AC wall outlet

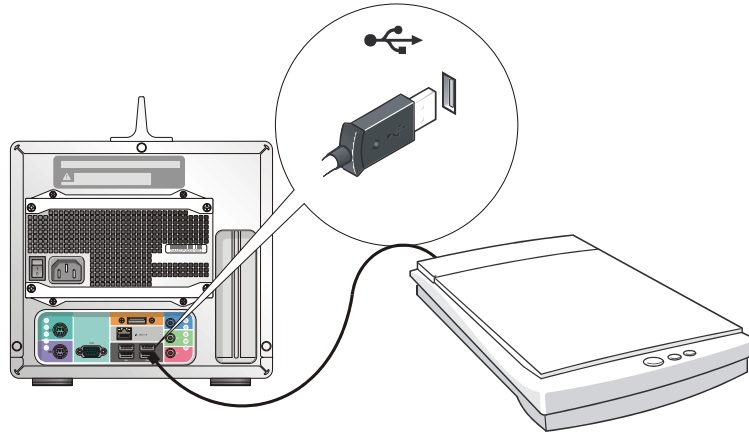

Connecting the Power Cords

- Plug the power cord into the back of the computer.
- Plug both the display and computer power cords into a grounded AC wall outlet or a power strip.

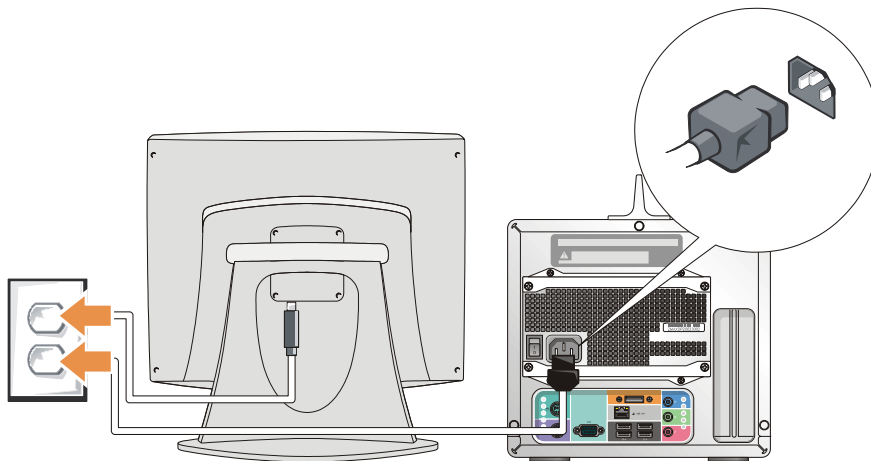

Connecting the USB peripherals

- Plug the USB cord into the front of the computer.

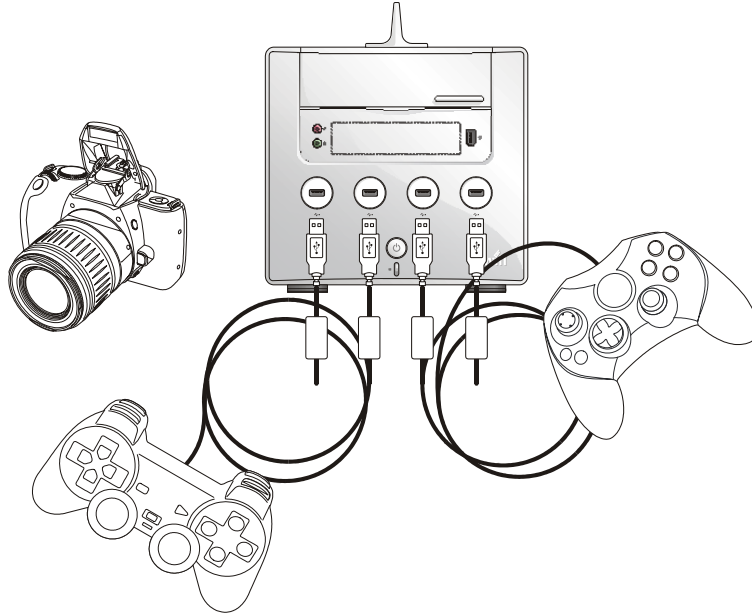

Connecting the IEEE1394 digital video camcorder

- Plug the IEEE1394 cord into the front of the computer.

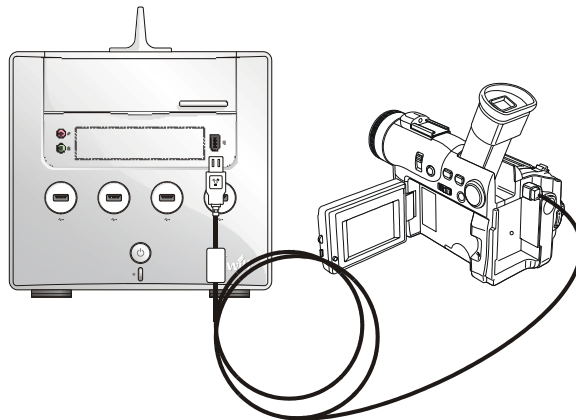

Connecting the Speakers

- Plug the Speaker cord into the rear of the computer by Audio Line Out.

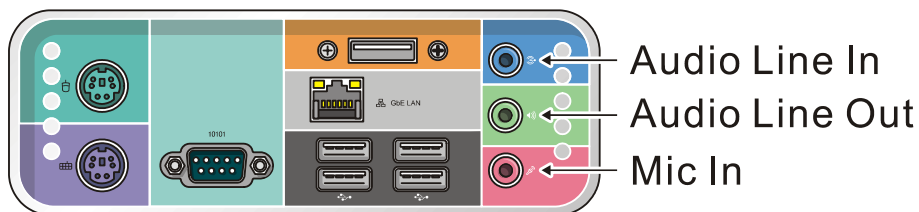
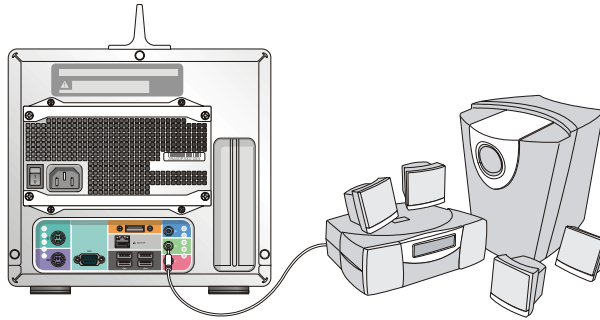

1. **Line In jack.** This Line In (light blue) jack connects a tape player or other audio sources. In 6-channel mode, the function of this jack becomes Bass/Center.
2. **Line Out jack.** This Line Out (lime) jack connects a headphone or a speaker. In 4-channel and 6-channel mode, the function of this jack becomes Front Speaker Out.
3. **Mic In, Microphone jack.** This Mic (pink) jack connects a microphone. In 4-channel and 6-channel mode, the function of this jack becomes Rear Speaker Out.

Arranging your workspace

Here are some guidelines to help you find better way to use your computer.

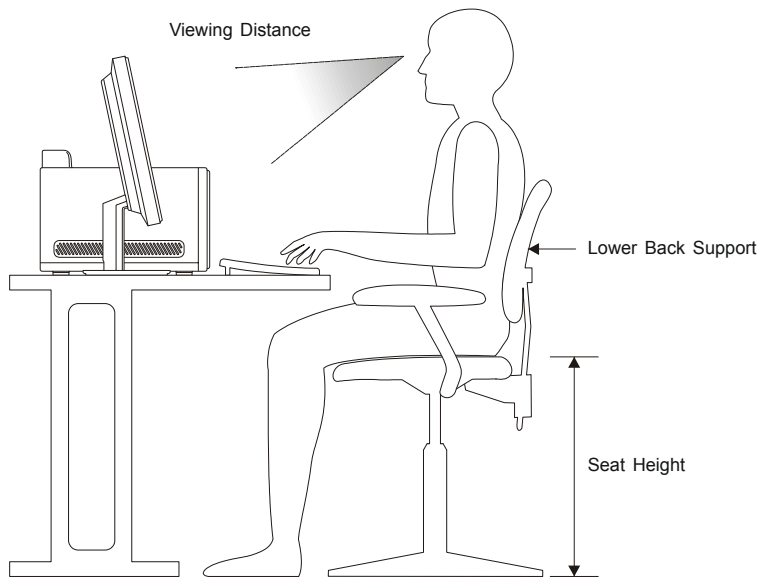

- Sitting in the same position for a long time can cause fatigue.
- A good chair can make a big difference. The backrest and seat should adjust independently and provide good support.
- The seat should have a curved front to relieve pressure on the thighs. Adjust the seat so that your thighs are parallel to the floor and your feet are either flat on the floor or on a footrest.
- When using the keyboard, keep your forearms parallel to the floor and your wrists in a neutral, comfortable position.
- Adjust the monitor so the top of the screen is at, or slightly below, eye level.
- Place the LCD monitor at a comfortable viewing distance, usually 50 to 60 cm.

Also position other equipment you use regularly, such as the telephone or a mouse, within easy reach.

Chapter 4

This chapter gives information about the IWILL motherboard that came with the system. This chapter includes the motherboard layout, jumper settings, and connector locations..

Introduction

The ZMAXdp mainboard is a high-performance motherboard that supports the AMD Opteron™ with 940-pin socket. This board has two DIMM memory sockets that support maximum 2GB DDR SDRAM and AGP 8X, PCI for future expansion.

The board uses the latest nVIDIA® nFORCE 3 PRO 250 MCP to integrate all system control functions. Features of this system include support for:

- Two AMD Opteron™ 2xx series processors
- Scalable Hyper-Transport Bus
- 2 x 184-pin DDR DIMM sockets for up to 2GB memory that supports registered ECC and non-ECC PC3200/PC2700/PC2100 DDR DIMMs
- One AGP 8X slot
- One 32-bit PCI/33 MHz slot
- Onboard 10BASE-T/100BASE-TX Ethernet port
- Eight USB 2.0 external ports on rear and front panel
- IEEE1394 6-pin external ports on front panel

For a complete list of specifications, see detail specifications.

ZMAXdp motherboard layout

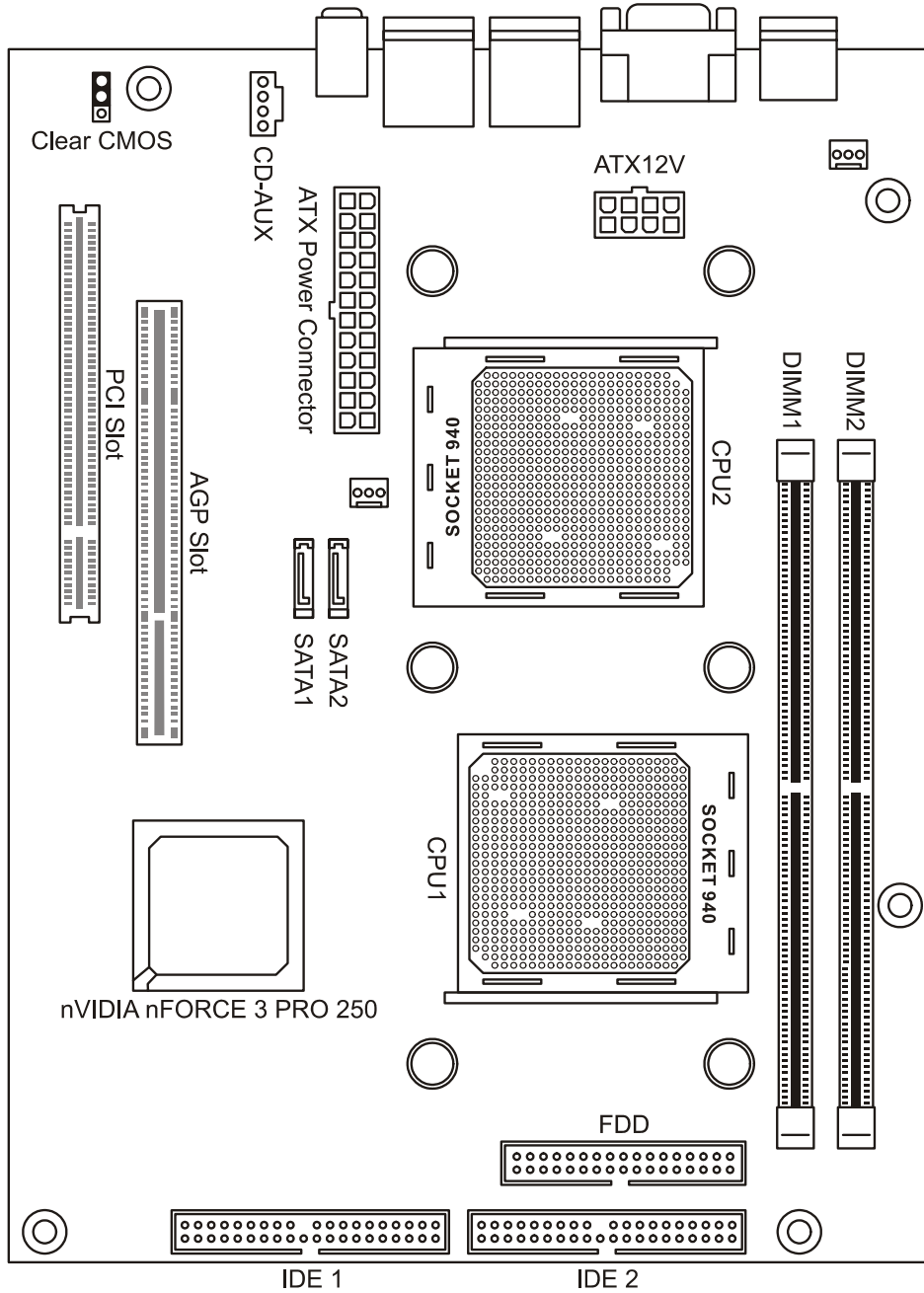

Rear External Connectors

PS/2 Ports

The PS/2 ports are for a system keyboard and mouse or other tracking device. It is recommended that you do not plug or unplug devices when the system is on.

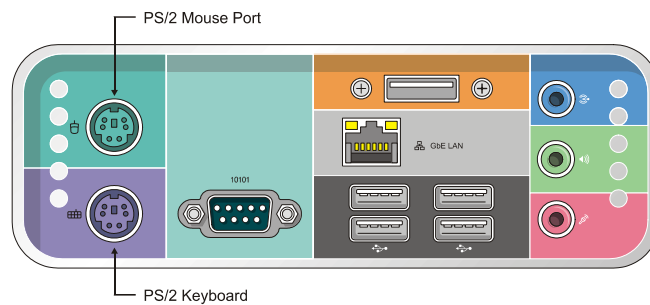

Serial Port

The COM Serial port has a 9-pin connector and can operate at speeds up to 115,200bps. Do not connect or disconnect a serial port when the system is turned on.

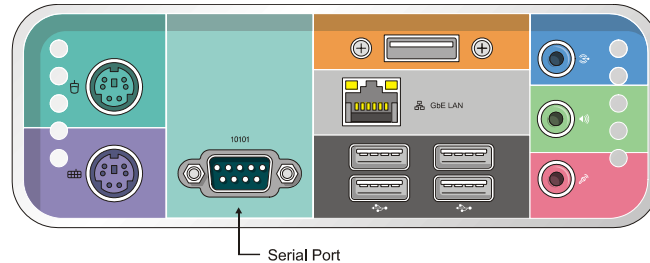

External SATA Port

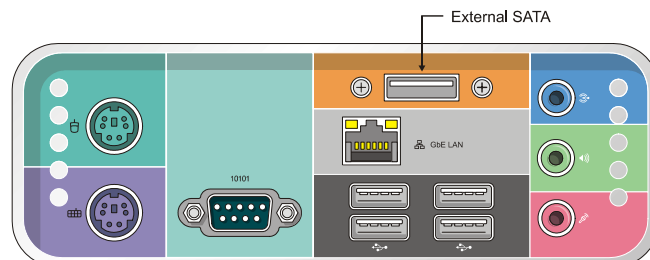

Ethernet Ports

The two LAN Ports are RJ-45 connectors for standard Cat 5 LAN cabling. The connectors attach to the onboard CK8 MAC and MARVELL GbE PHY respectively.

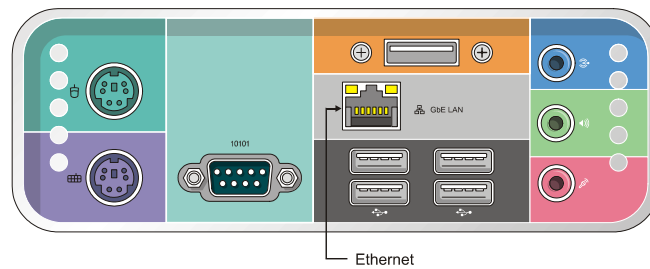

USB Ports

There are four high-speed USB 2.0 ports, USB 0 and USB 1, for connecting either USB 1.1 or 2.0 devices to the system. It does not matter if the system is on when you connect or disconnect USB devices. See the graphic below.

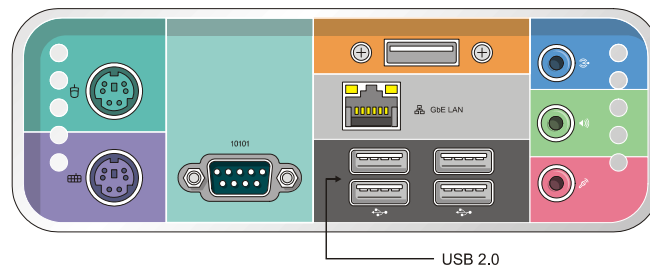

Audio Jacks

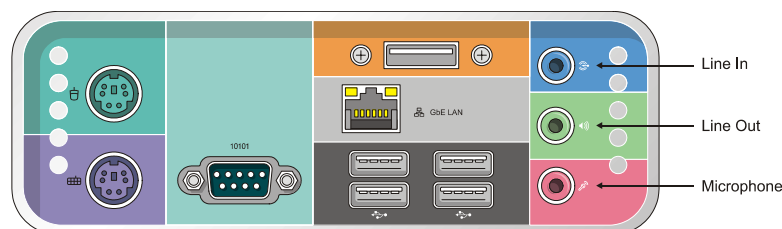

Line In: provides audio input connector for an external audio source.

Speaker: offers output to two stereo speakers.

Microphone: this jack is for plugging in a computer microphone.

Central Processing Unit and System memory

CPU Socket

The ZMAXdp supports a two 940-pin AMD Opteron™ processor. The CPU requires pair heatsink,.

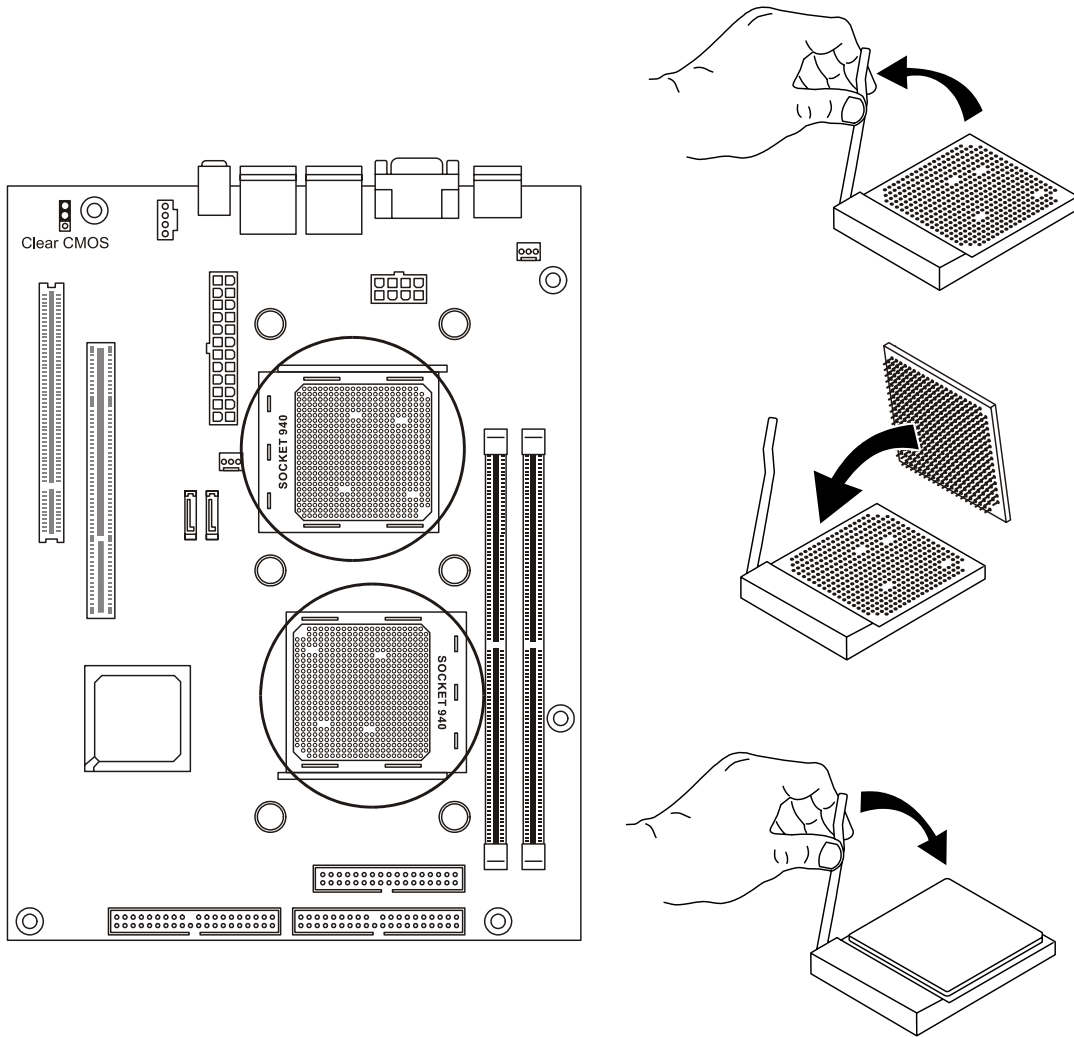

System Memory Socket

This DIMM system memory socket supports DDR 400/333/266 SDRAM system memory modules. Flexible memory technology allows a full spectrum of DDR usage from highest performance to more cost-effective systems.

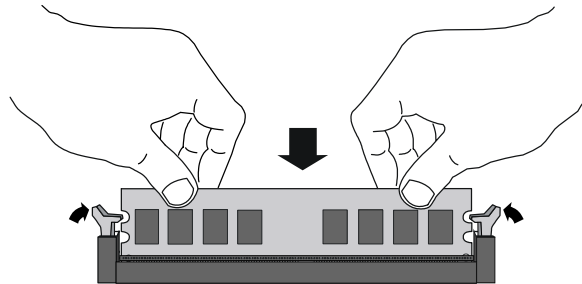
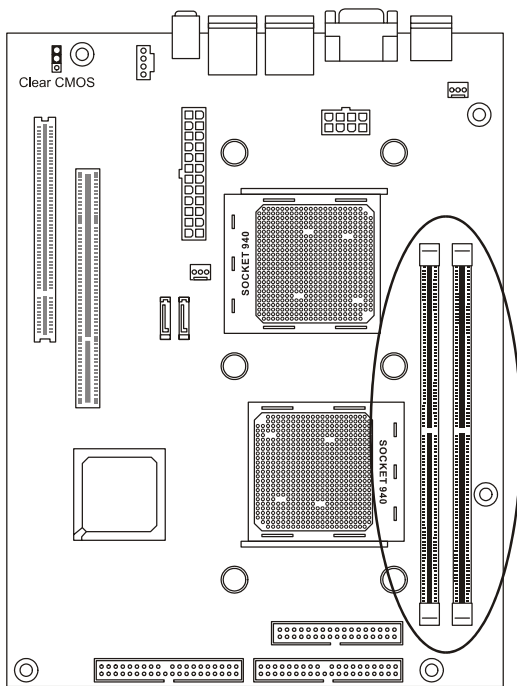

Expansion Slot

PCI Slot, The PCI expansion slot on the ZMAX version lets you install additional system hardware via add-on cards. There is one 32-bit, 33MHz slot that is compliant with PCI 2.1/2.2 on this motherboard.

AGP Slot, The AGP slot is for the exclusive use of high speed AGP video display cards. This AGP slot supports AGP4X/8X cards. This slot only supports 1.5V devices. Do not use a 3.3V AGP card with this motherboard.

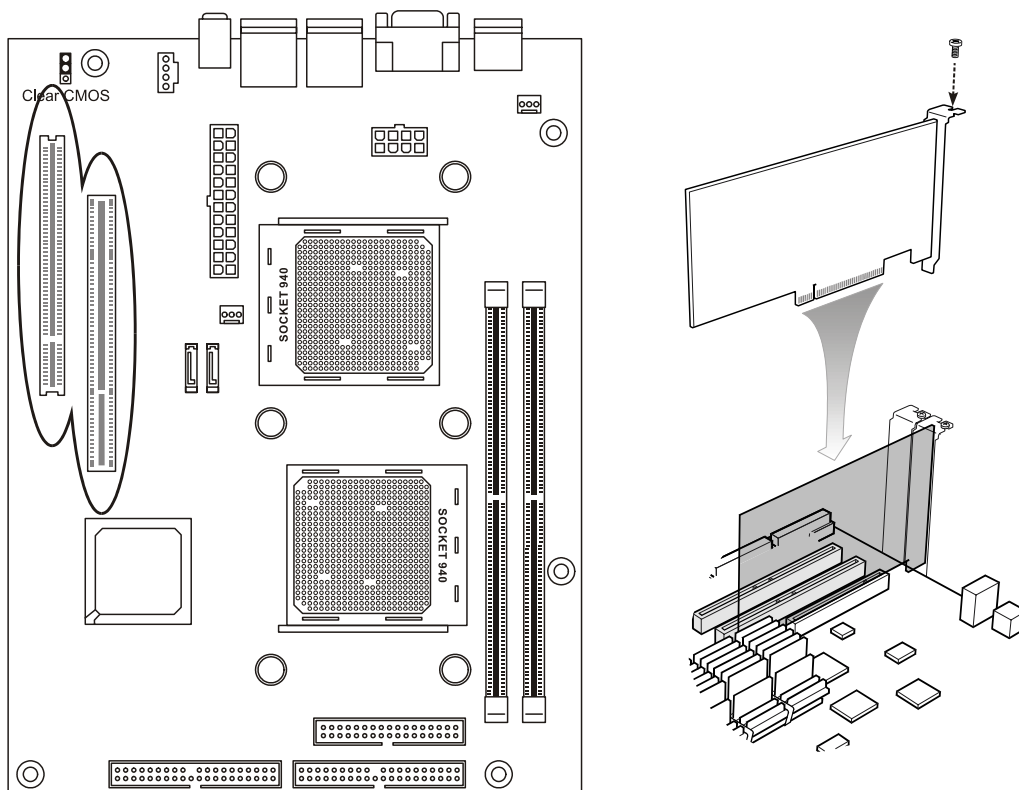

When you installing AGP card, please make sure the following notice is fully understood and practiced. If your AGP card has "AGP 4X/8X notch"(show below), please make sure your AGP card is AGP 4X/ 8X (1.5V).

Do not use AGP 2X card (3.3V) in this system. It will burn and damage the motherboard

Mini PCI Slot

The mini PCI slot is used to connect wireless LAN card or additional Mini PCI card.

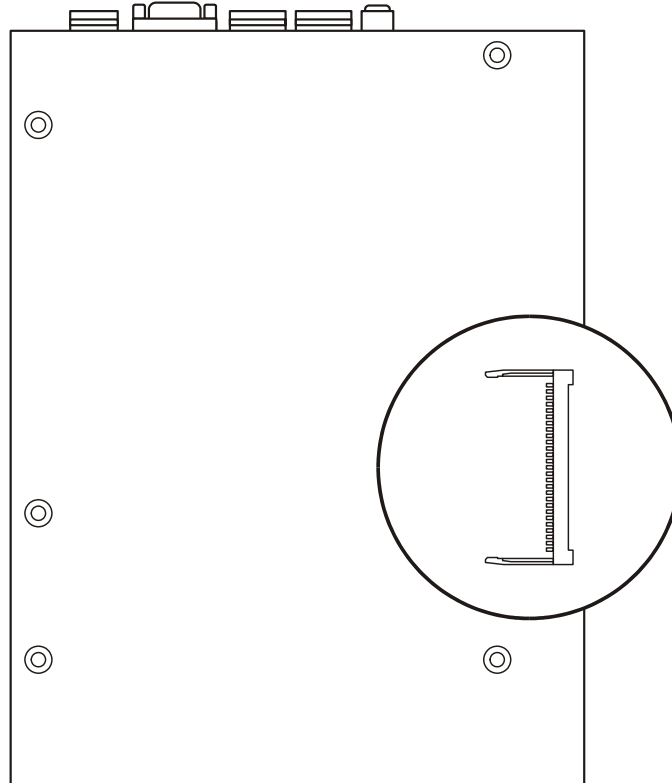

Before you installed any card on this board

- Please unplug the power cord from the wall socket before touching any component.
- Wear a grounded wrist strap or touch a safely grounded object or to a metal object, such as the power supply, before handling components to avoid damaging them due to static electricity.
- Whenever you uninstall any component, place it on a grounded antistatic pad or in the bag that came with the component.
- Before you install or remove any component, ensure that the ATX power supply is switched off or the power cord is detached from the power supply. Failure to do so may cause severe damage to the motherboard, peripherals, and/or components.

Jumpers Setting

Clear CMOS Jumper

This jumper switch clears the RTC RAM CMOS Setup configuration that is stored in the real-time clock's CMOS memory. If configuration becomes corrupted, or if the CMOS settings are changed to an unsuitable configuration, the motherboard may not work properly. This jumper lets you delete the configuration data stored in CMOS memory and reset the CMOS to the Optimized Defaults. Follow the procedure below to clear CMOS memory.

1. Turn off and unplug the system and remove the system housing cover.
2. Set Clear CMOS position by placing the jumper cap over pins 2 and 3 for one minute.
3. Return the jumper cap to Normal setting, pins 1 and 2.
4. Replace the system housing cover, plug in the system and power on.
5. Run the CMOS Setup Utility and load the Optimized Defaults. Make any custom settings you require.
6. Save the settings as you exit the program and restart your computer.

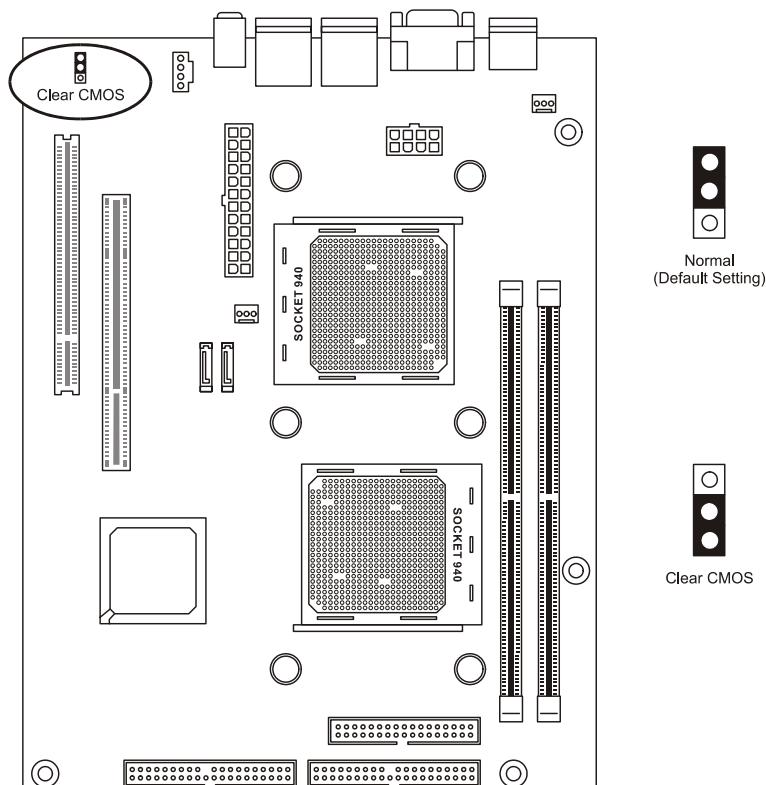

Internal Connectors

IDE1, IDE2: IDE Drive Connectors

The two IDE drive connectors are marked IDE1, the primary channel, and IDE2, the secondary channel. Each connector supports two drives, a Master and a Slave.

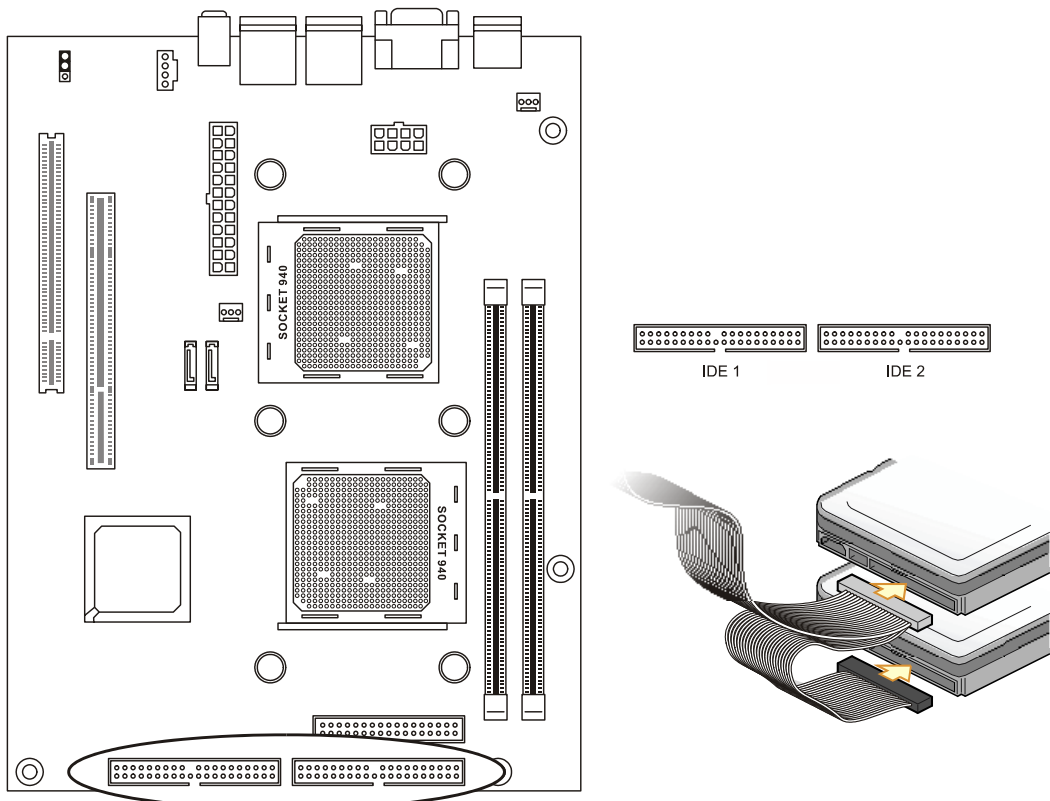

Pin 20 on each IDE connector is removed to match the covered hole on the UltraDMA cable connector. This prevents incorrect orientation when you connect the cables. For UltraDMA100/66 IDE devices, use an 80-conductor IDE cable.



The red stripe of the ribbon cable must be the same side with the Pin1.

SATA Drive Connectors

These SATA connectors support the thin Serial ATA cables for primary internal storage devices. The current Serial ATA interface allows up to 150 MB/s data transfer rate, faster than the standard parallel ATA with 133 MB/s (UltraDMA133).

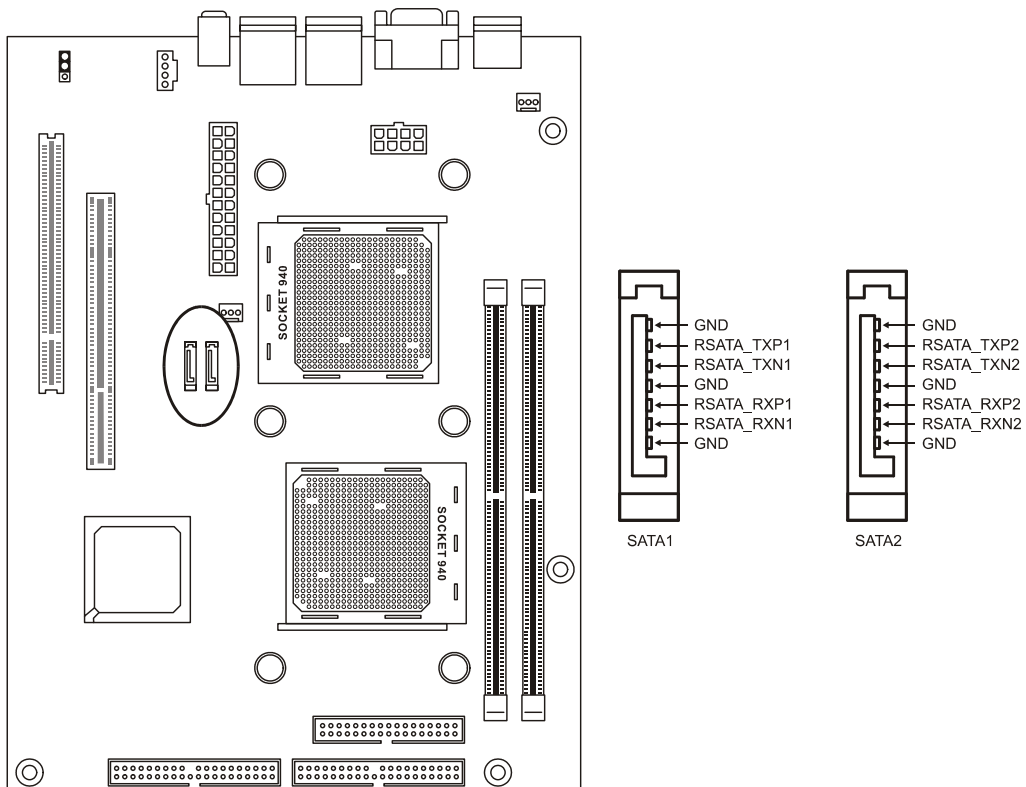

The Serial ATA cable is smaller and more flexible allowing easier routing inside the chassis. The lower pin count of the Serial ATA cable eliminates the problem caused by the wide, flat ribbon of the Parallel ATA interface.



Hot plug support for Serial ATA drive and connections are not available in this barebone.

Power Connectors

The two power connectors let you attach two leads from an ATX12V power supply to the motherboard. The board requires a 24-pin ATX connector plus a 8-pin ATX12V connector. Insert the 24-pin lead of the ATX12V power supply into the first 20 holes of the power connector leaving the last four empty. Insert the 8-pin ATX12V lead into the another power connector.

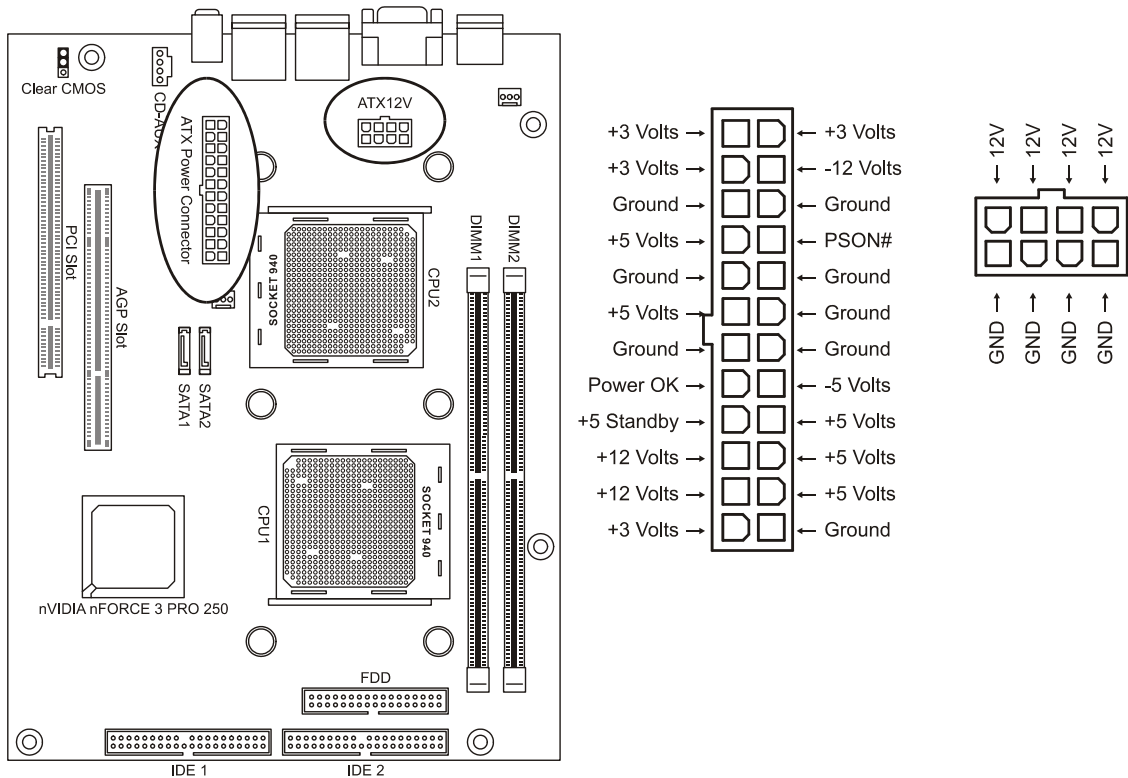

this page intentionally left blank

Chapter 5

This chapter gives information about the ZMAX Basic Input/Output System (BIOS) operation.

The ZMAXdp BIOS provides the Power-On Self-Test (POST), the BIOS Setup program, the PCI and IDE auto-configuration utilities. Refer this chapter for more information about the BIOS.

The BIOS includes security features that restrict whether the BIOS Setup program can be accessed and who can boot the computer. A supervisor password and a user password can be set for the BIOS Setup and for booting the computer.:

BIOS Setup

Updating Your BIOS

Creating a bootable floppy disk

A. DOS environment

Insert a 1.44 MB floppy disk into the drive.

At the DOS prompt, type:

format A:/S then press <Enter>.

B. Microsoft® Windows® environment

- a. Insert a 1.44 MB floppy disk into the floppy disk drive.
- b. From your Windows desktop, click on Start, then select My Computer.
- c. Select the 3 1/2 Floppy Drive icon.
- d. Click File from the menu, then select Format. A Format 3 1/2 Floppy Disk window appears.
- e. If you are using Windows™, select Create an MS-DOS startup disk from the format options field, then click Start.

Move the latest BIOS file to the bootable floppy disk.

Using “AMIFLASH.EXE” to update the BIOS

Update the BIOS using the AMIFLASH.EXE utility in DOS environment.

1. Visit the IWILL website (<http://www.iwill.net>) to download the latest BIOS file for your motherboard. Save the BIOS file to a bootable floppy disk.
2. At the DOS prompt, type the command line:

AMIFLASH / <filename>

where “filename” means the latest (or original) BIOS file that you copied to the bootable floppy disk. The screen displays the status of the update process.

```
A:\>amiflash /zmdp1019.rom
AMI Firmware Update Utility - Version 1.10
Copyright (C) 2002 American Megatrends, Inc. All rights reserved

Reading file ..... done
Erasing flash .... done
Writing flash .... 0x0008cc00 (12%)
```



The BIOS information on the screen is for reference only. What you see on your screen may not be exactly the same as shown.



DO NOT shutdown or reset the system while updating the BIOS! Doing so may cause system boot failure!

3. When the BIOS update process is complete, the utility returns to the DOS prompt.

```
A:\>amiflash /zmdp1019.rom
AMI Firmware Update Utility - Version 1.10
Copyright (C) 2002 American Megatrends, Inc. All rights reserved

Reading file ..... done
Erasing flash .... done
Writing flash .... 0x0008cc00 (100%)
Verifying flash ...done
A:\
```

BIOS Setup program

This chapter discusses the AMI® BIOS Setup program built into the ROM BIOS. The Setup program allows users to modify the basic system configuration.

The BIOS is the Basic Input / Output System used in all IBM PC, XT, AT, and PS/2 compatible computers. The AMIBIOS flash chip stores the system parameters, such as type of disk drives, video displays, etc. in the CMOS. When the computer is turned off, a back-up battery provides power to the BIOS flash chip, enabling it to retain system parameters. Each time the computer is powered-on the computer is configured with the values stored in the BIOS ROM by the system BIOS, which gains control at boot-up.

The AMI® BIOS installed in your computer system's ROM (Read Only Memory) is a custom version of an industry standard BIOS. The BIOS provides critical low-level support for standard devices such as disk drives and serial and parallel ports.

STARTING THE BIOS SETUP

The AMI® BIOS is immediately activated every time you power on the system. The BIOS reads the system information contained in the CMOS and begins the process of checking the system and configuring it. After configuring the system, the BIOS will follow the Boot Order to seek out an operating system. The BIOS then turns control of the system over to the operating system.

The CMOS information that determines the system parameters may be changed by entering the BIOS Setup utility.

1. Power on the System. Note: Normally, the only visible POST (Power On Self Test) routine is the memory test.
2. As the memory is being tested, you can access the BIOS Setup Utility by pressing the <F2> key when "Press < F2> to enter SETUP" appears briefly at the bottom of the screen.

From the main menu of the BIOS Setup Utility, you can access the other setup screens, such as the Security and Power menus.

Using The BIOS Setup Utility

Navigating through the BIOS Setup Utility is straightforward. Use the arrow keys to highlight items, press <Enter> to select items in menus, and press <Esc> to quit. The following table provides more details about how to navigate in the Setup program using the keyboard.

Up ArrowKey	Move to the previous item
Down Arrow Key	Move to the next item
Left Arrow Key	Move to the previous menu
Right Arrow Key	Move to the next menu
<Esc> key	Exit the submenu or Exit Menu
<Enter> Key	Select the highlighted item or select the item value or select a submenu
<PgUp> Key	Previous page on Scrollable menus or Jump to the first interactive item listed
<PgDn> Key	Next page on Scrollable menus or Jump to the last interactive item listed
<F1> Key	General Help on Setup navigation keys.
<F2>/<F3> Key	Change Colors
<F7> Key	Discard Changes
<F8> Key	Load Failsafe Defaults
<F9> Key	Load Optimal Defaults
<F10> Key	Save and Exit
Home	Go to Top of Screen
END	Go to Bottom of Screen

IMPORTANT

The BIOS does NOT automatically save values that you have modified. If you do not save your values before you exit the BIOS Setup Utility, all your changes will be lost.

If after making and saving system changes with the BIOS Setup Utility, you discover that your computer is no longer able to boot, the AMIBIOS® supports an override, which will reset your system to the Failsafe defaults. If that fails, it is possible to manually clear the present CMOS information through the "Clear CMOS Header" on the motherboard (Refer to Jumper Settings for more information).

The best advice is to ONLY alter settings that you thoroughly understand. The default settings have been carefully chosen by AMIBIOS® to provide the maximum system performance and reliability. Even a slight change to the chipset setup may cause potential and unpredictable failure to the system.

Main Menu

This is the first screen that is displayed when you enter the BIOS Setup Utility. Each tab lined on the top of the screen represents each different menu. The following picture shows the main menu. Main menu shows the information of BIOS version, date and ID; processor type, speed and count; system size. In addition, system time and date is adjustable using + / - key or number keys.

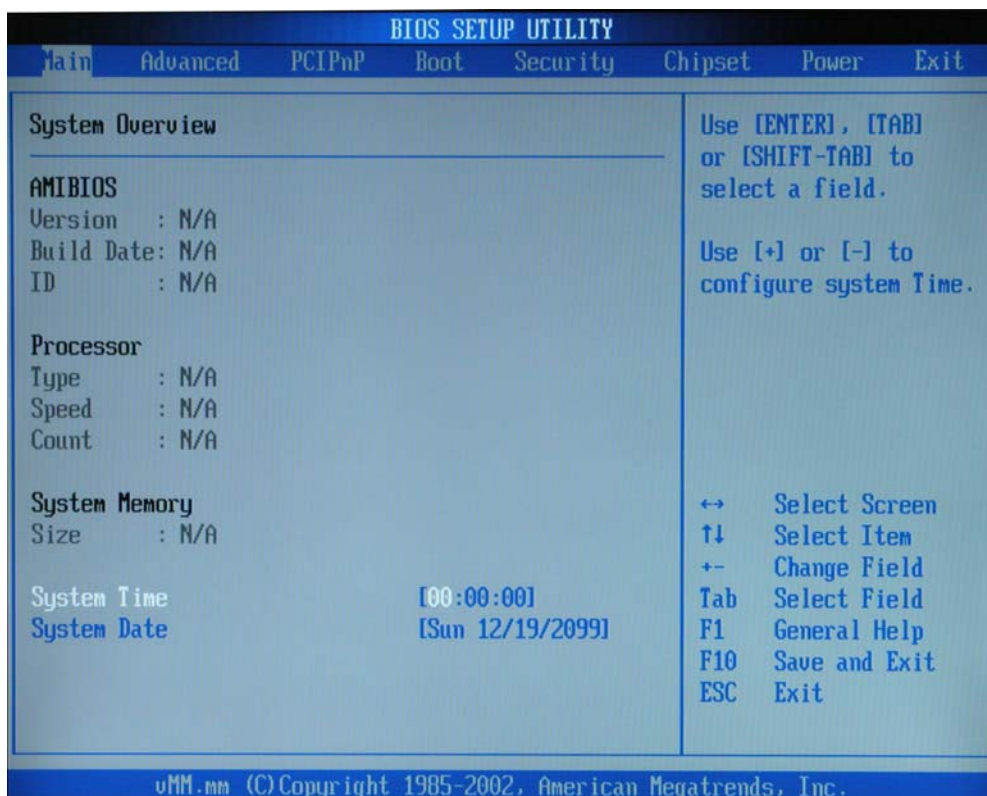

BIOS Setup Main Menu

Use the arrow keys to select items. A description of each selection follows.

Advanced Menu

This is the Advanced Menu screen.

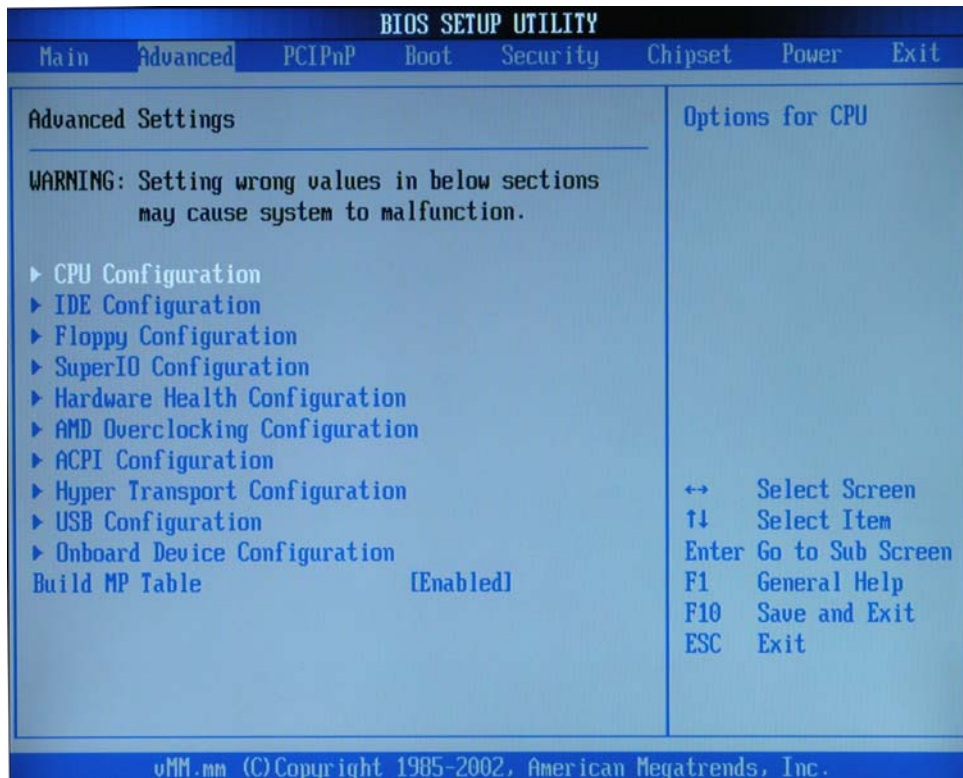

You can make these modifications on the Advanced Menu. Select the Submenus to modify those settings.

Feature	Option	Description
CPU Configuration	GART Error Reporting	Enable only for testing purpose
IDE Configuration		Enable or Disable IDE Controller
SuperIO Configuration		Configures devices connected to the Super I/O Configuration
Floppy Configuration	Disabled 360 KB, 5 1/2" 1.2 MB, 5 1/2" 720 KB, 3 1/2" 1.44 MB, 3 1/2" 2.88 MB, 3 1/2"	Select Floppy A or Floppy B and then selects floppy-diskette type installed in your system.
Hardware Health Configuration	H/W health function and H/W thermal throttling Disabled/Enabled	<ol style="list-style-type: none"> 1. Enable/Disable H/W health function 2. Thermal throttling allows the user to reduce CPU duty cycle to a user defined percentage when the temperature reaches a user defined value 3. H/W health event
ACPI Configuration	ACPI Aware O/S Yes/No	Enable: If O/S supports ACPI Disable: If O/S doesn't support ACPI
Hyper Transport Configuration	CPU0: CPU1 HT Link Speed/Width	Hyper Transport link speed/width is adjustable
USB Configuration	Legacy USB Support Disabled/Enabled/Auto USB Mass Storage Device Configuration	<ol style="list-style-type: none"> 1. Enables support for legacy USB. Auto option disables legacy support if no USB devices are connected 2. Configure the USB mass storage class devices
Onboard Device Configuration	SATA and 1394 controller	Enable or disable onboard SATA and 1394 controller

IDE Configuration Submenu

You can also setup your PCI IDE controller on Advance menu.

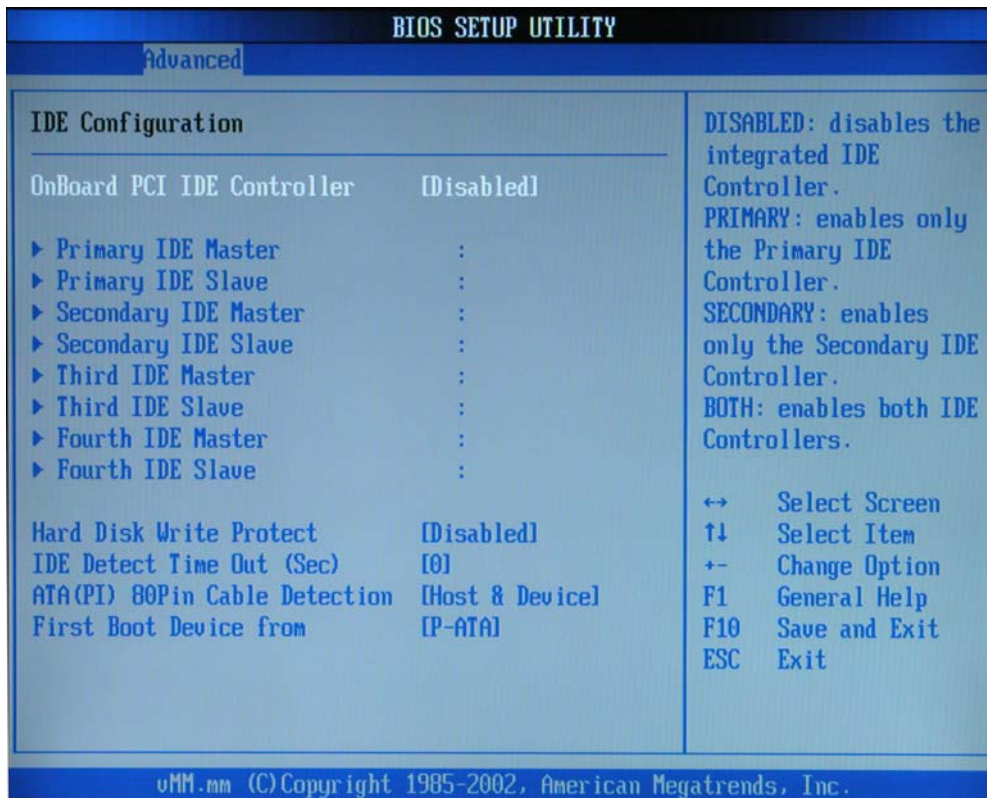

Super IO Configuration Submenu

Feature	Option	Description
Onboard Floppy Controller	Disabled Enabled	Allows BIOS to enable or disable floppy controller
Onboard Game/Midi Port	Disabled 200/300, 200/330 208/300, 208/330	Allows BIOS to enable or disable Game/Midi port
Keyboard PowerOn Function	Disabled Any Key	

PCI PnP

You can use this screen to view PnP (Plug & Play) BIOS Configuration Menu. This menu allows the user to configure how the BIOS assigns resources & resolves conflicts. Use the up and down arrow (/) keys to select an item. Use the Plus and Minus (+/-) keys to change the value of the selected option. The settings are described on the following pages.

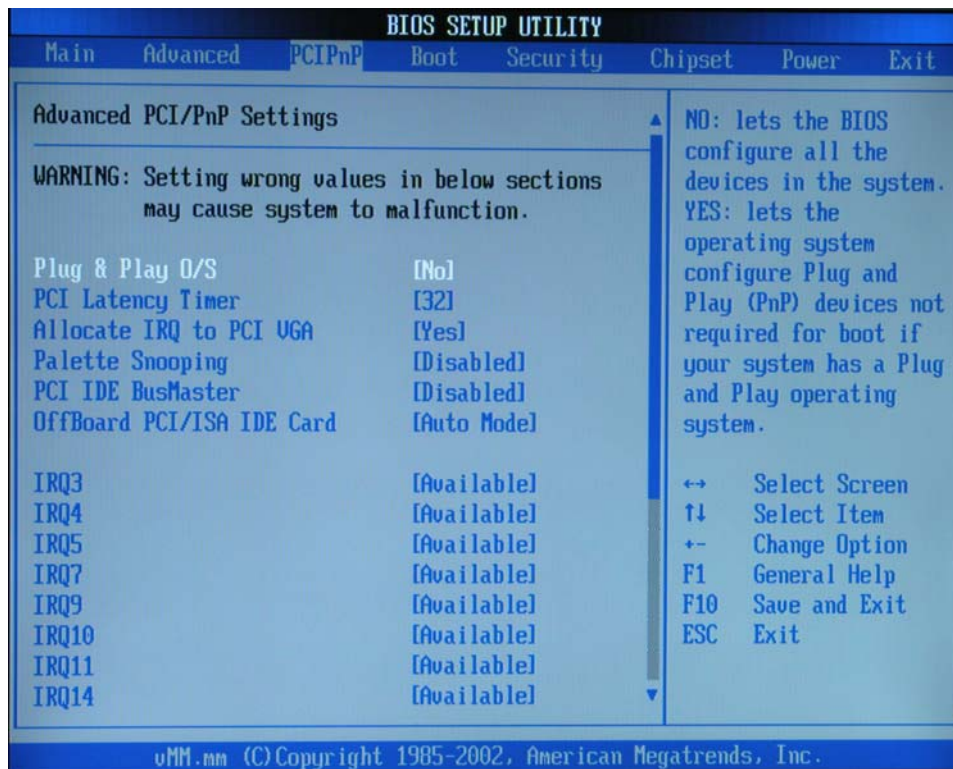

Feature	Option	Description
Plug & Play O/S	Yes No	Yes: lets the O/S configure PnP devices not required for boot if your system has a Plug and Play O/S
PCI Latency Timer	32, 64, 96, 128, 160, 192, 224, 248	Value in units of PCI clocks for PCI device latency timer register
Allocate IRQ to PCI VGA	Yes No	Yes: Assign IRQ to PCI VGA card if card requests IRQ No: Doesn't assign IRQ To PCI VGA cars even if card requests IRQ
Palette Snooping	Disabled Enabled	Enabled: informs the PCI devices that an ISA graphics device is installed in the system so the card will function correctly
PCI IDE BusMaster	Disabled Enabled	Enabled: BIOS uses PCI busmastering for reading/writing to IDE drives
Offboard PCI/ISA IDE card	Auto PCI Slot1 PCI Slot2 PCI Slot3 PCI Slot4 PCI Slot5 PCI Slot6	Some PCI IDE cards may require this to be set to the PCI slot number that is holding the card.
IRQ 3,4,5,7,9,10,11,14,15	Available Reserved	Available: specified IRQ is available to be used by PCI/PnP devices Reserve: specified IRQ is reserved for use by legacy ISA devices
DMA Channel 0, 1, 3, 5, 6, 7	Available Reserved	Available: specified DMA is available to be used by PCI/PnP devices Reserve: specified DMA is reserved for use by legacy ISA devices
Reserved Memory Size	Disabled 16K 32K 64K	Size of memory block to reserve for legacy ISA devices

Boot Configurations

You can display Boot Setup option by highlighting it using the Arrow (↑/↓) keys and pressing Enter. The settings are described on the following pages.

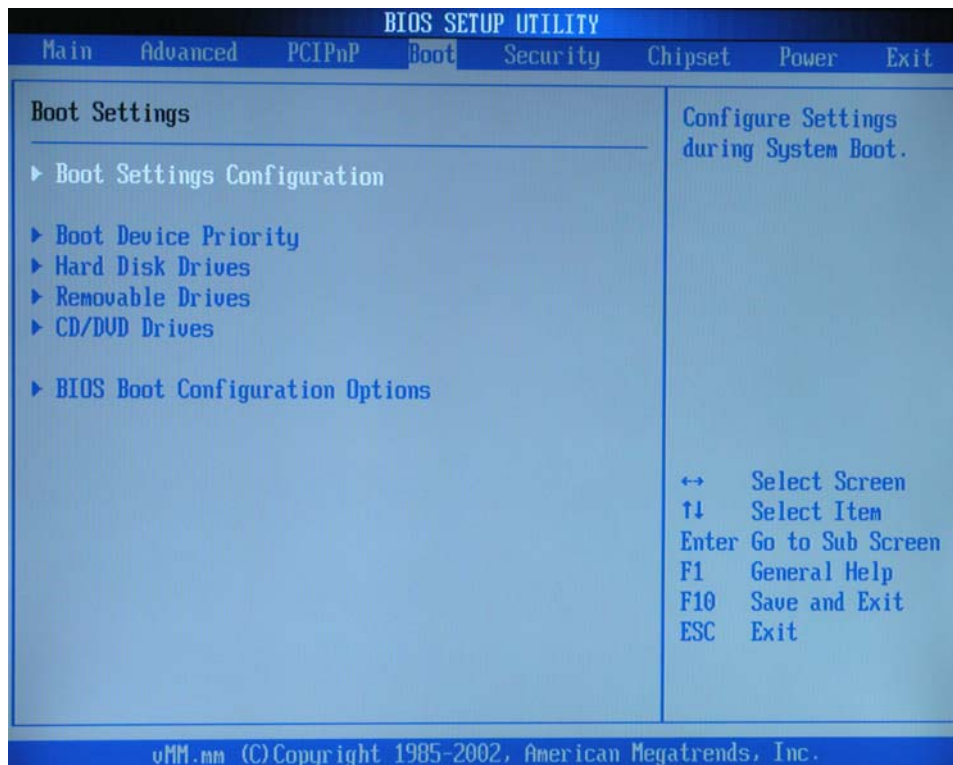

Boot Settings Configuration Sub-Menu

Use this screen to select options for the Boot Settings Configuration. Use the up and down arrow (↑/↓) keys to select an item. Use the Plus and Minus (+/-) keys to change the value of the selected option.

Feature	Option	Description
Quick Boot Mode	Enabled/ Disabled	This option allows user bypass BIOS self test during POST
Quiet Boot	Disabled Enabled	Enable this option to hide BIOS Post messages during POST
Quick Boot Add On ROM Display Mode	Force BIOS Keep Current	Allows user to force BIOS/Option ROM of add on cards to be displayed during quiet boot
Boot up Number-Lock	On Off	Choose status of keyboard NUM LOCK key
PS/2 Mouse Support	Enabled Disabled	Allows user to choose status of PS/2 mouse support
Typematic Rate	Fast Slow	Choose the speed at which keys are repeated
System Keyboard	Present Not-Present	Allows user to disable all system keyboards
Parity Check	Disabled Enabled	Enables system parity check
Boot To OS/2	No Yes	Set this option to yes only if booting to OS/2
Wait for "F1" If Error	Enabled Disabled	Allows user to disable the "Press F1 to Continue" error message when error is detected
Hit "Del" Message Display	Enabled Disabled	Allows user to disable the "Press DEL to enter setup" message during POST
Interrupt 19 Capture	Disabled Enabled	Allows devices (such as network card) to capture INT19 for booting

BIOS Security Menu

The system can be configured so that all users must enter a password every time the system boots or when BIOS Setup is entered, using either the Supervisor password or User password. The Supervisor and User passwords activate two different levels of password security. If you select password support, you are prompted for a one to six character password. Type the password on the keyboard. The password does not appear on the screen when typed. Make sure you write it down. If you forget it, you must clear CMOS and reconfigure.

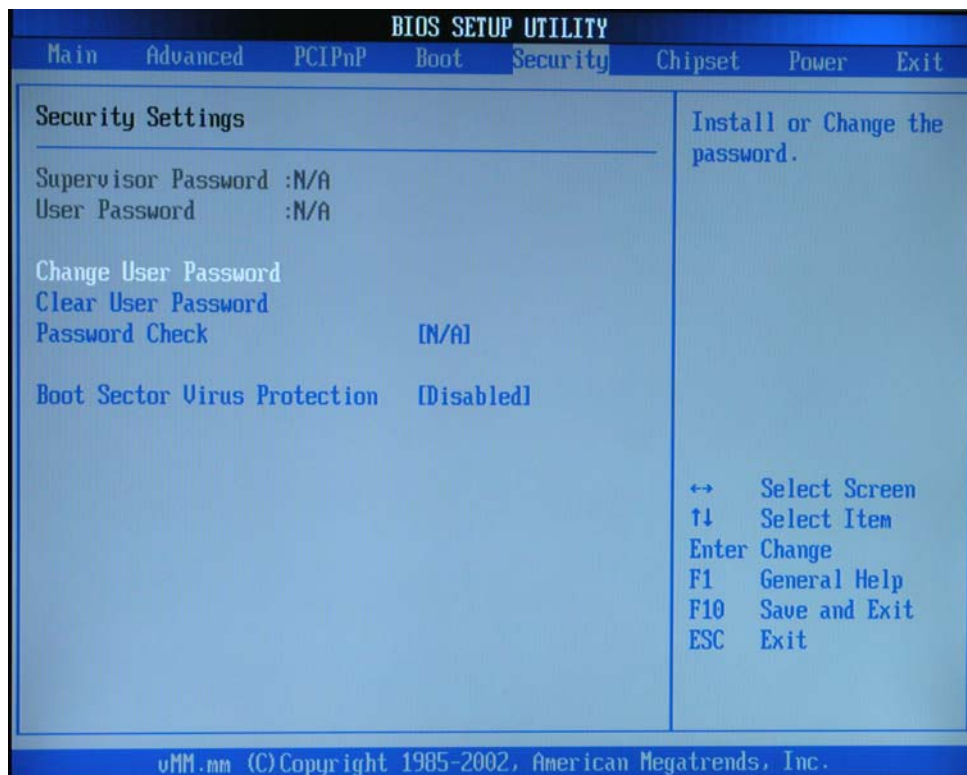

Change Supervisor Password

Select this item to set or change the supervisor password. The Supervisor Password item on top of the screen shows the default Not Installed. After you have set a password, this item shows Installed.

To set a Supervisor Password:

1. Select the Change Supervisor Password item and press Enter.
2. On the password box that appears, you can type a password composed of letters and/or numbers, and press Enter. Your password should have at least six characters.
3. Confirm the password when prompted. The message "Password Installed" appears after you have successfully set your password.
4. The Supervisor Password item now shows Installed.

To change the supervisor password, follow the same steps as in setting user password. To clear the supervisor password, select the Change Supervisor Password then press Enter. The message "Password Uninstalled" appears.



If you forget your password, you can clear it by clearing (erasing) the CMOS RTC (Real Time Clock RAM). See Chapter 4 "**Clear CMOS Jumper**" for more information on how to erase the RTC RAM.

BIOS Chipset Configurations

There are three submenus inside Chipset menu: NorthBridge Configuration, SouthBridge Configuration and AGP Configuration.

This menu allows the user to customize functions of the nVIDIA® nFROCE® MCP Chipsets. North Bridge configuration contains options for Memory & CPU settings. South Bridge configuration contains options for SM Bus & USB. Select a menu by highlighting it using the Arrow (↑/↓) keys and pressing Enter. The settings are described on the following pages.

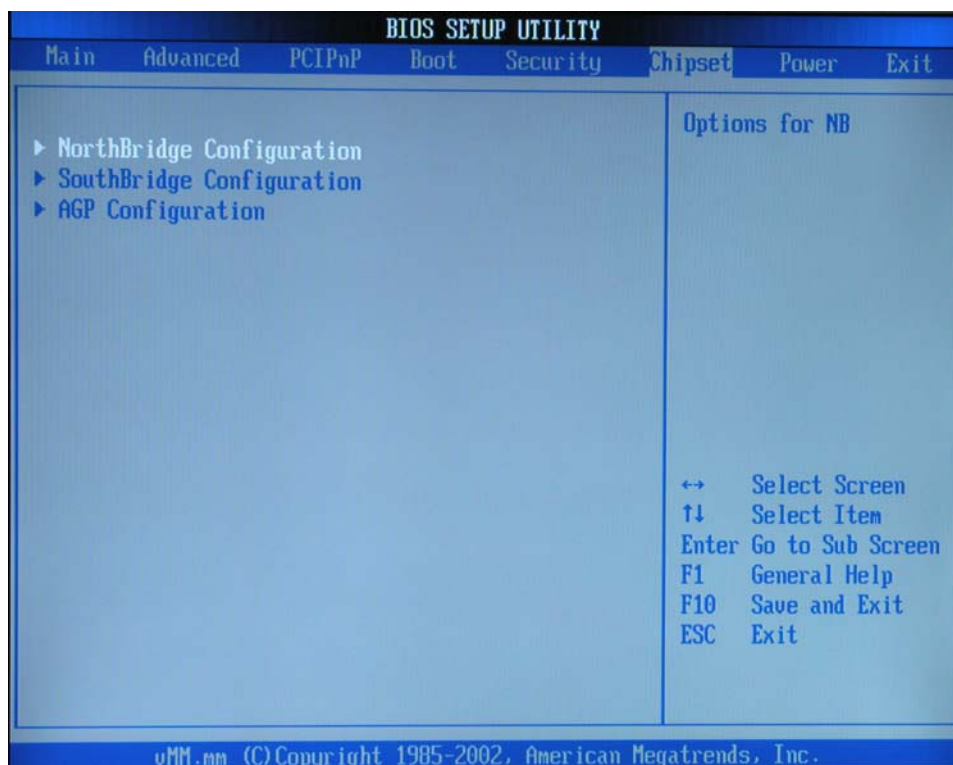

North Bridge Chipset Configuration Sub-Menu

This menu gives options for customizing memory settings. Select a menu by highlighting it using the Arrow (↑/↓) keys and pressing Enter. The settings are described on the following pages.

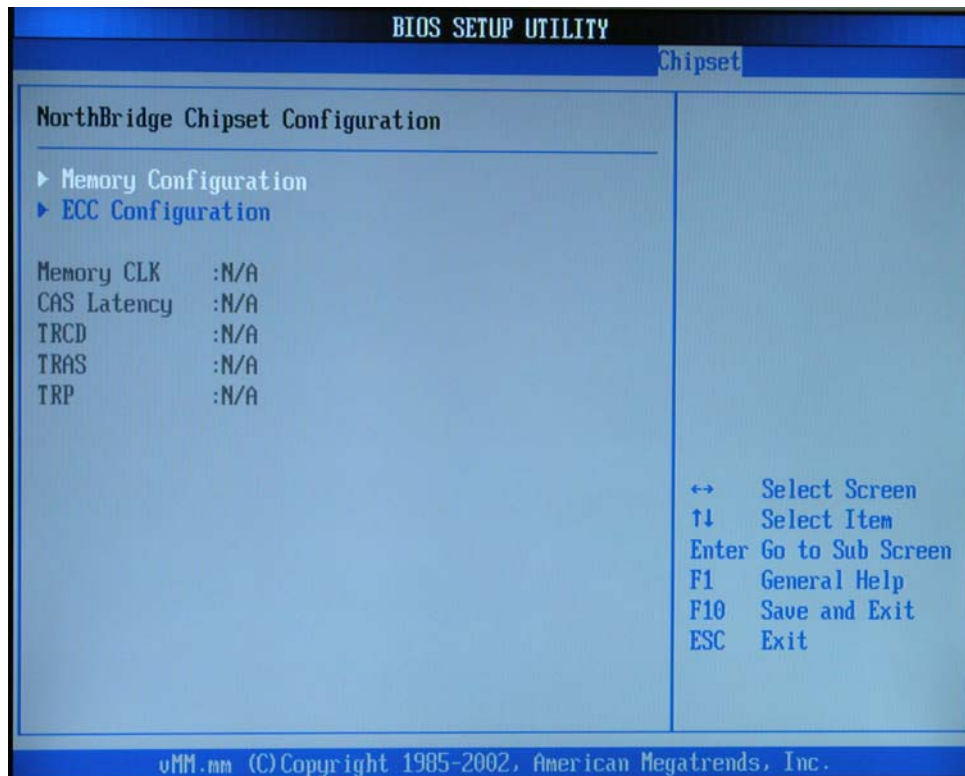

Memory Configuration Sub-Menu

This menu has options for memory speed & latency. Use the up and down arrow (↑/↓) keys to select an item. Use the Plus and Minus (+/-) keys to change the value of the selected option.

Feature	Option	Description
Bank Interleaving	Disabled	Allows memory access to be spread across memory banks
	Enabled	
Node Interleaving	Disabled	Allows memory access to be spread across memory nodes
	Enabled	
Burst Length	8beats	Burst length must be set to 8beats for 128bit memory support
	4beats	

ECC Configuration Sub-Menu

This menu allows the user to configure ECC setup for system & DRAM. Use the up and down arrow (↑/↓) keys to select an item. Use the Plus and Minus (+/-) keys to change the value of the selected option.

Feature	Option	Description
Master ECC	Enabled	Enables support on all nodes for ECC error checking and correction
	Disabled	
DRAM ECC	Disabled	Enables support on all banks for ECC error checking and correction
	Enabled	
L2 Cache BG Scrub	Disabled	Enables support for ECC when L2 cache is idle
	Enabled	
Data Cache BG Scrub	Disabled	Enables support for ECC when L1 cache is idle
	Enabled	

South Bridge Chipset Configuration Sub-Menu

This menu allows the user to enable SMBus, Audio Codec, MAC Bridge... interface. Use the up and down arrow (↑/↓) keys to select an item. Use the Plus and Minus (+/-) keys to change the value of the selected option.

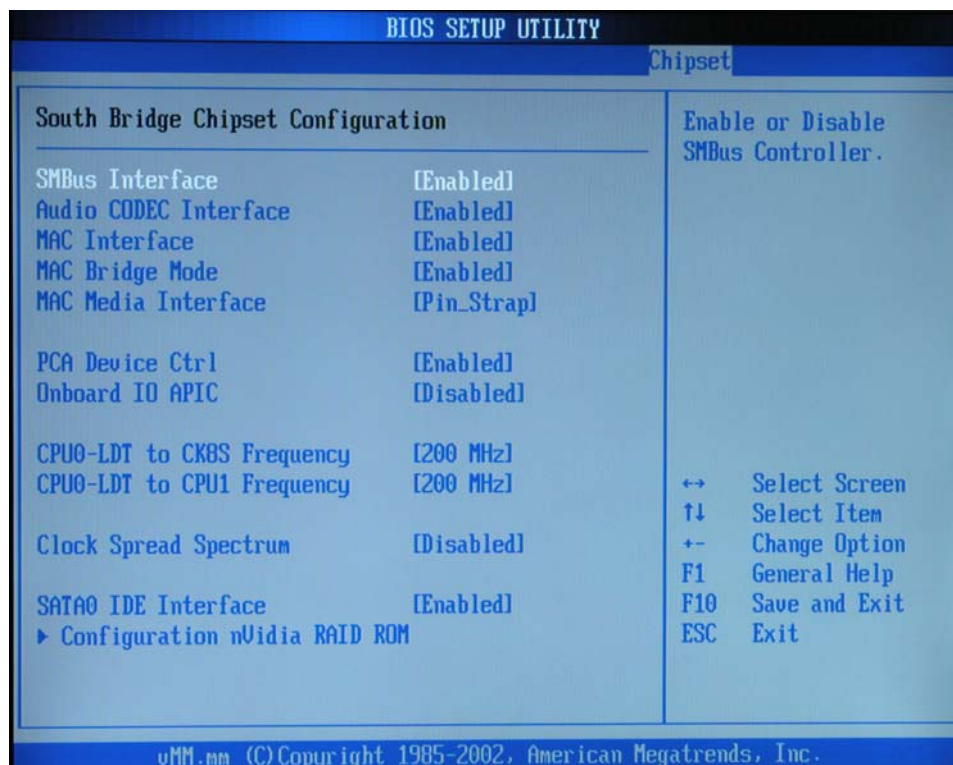

Power Menu

Use this screen to select options for power management & ACPI. Use the up and down arrow (↑/↓) keys to select an item. Use the Plus and Minus (+/-) keys to change the value of the selected option. A description of the selected item appears on the right side of the screen. The settings are described on this page. The screen is shown below.

Feature	Option	Description
Power Management /APM	Disabled Enabled	Disabled prevents the chipset power management and APM (Advanced Power Management) features. Enabled allows the chipset power management and APM features
Power Button Mode	On/Off Standby Suspend	Specifies how the externally mounted power button on the front of the chassis is used
Video Power down Mode	Suspend Standby Off	Specifies the Power State that the video subsystem enters when the BIOS places it in a power saving state after the specified period of display inactivity has expired
HDD Power down Mode	Suspend Standby Off	Specifies the power conserving state that the hard disk drive enters after the specified period of hard drive inactivity has expired

BIOS Exit Menu

The Exit menu items allow you to load the optimal or failsafe default values for the BIOS items, and save or discard your changes to the BIOS items.



Pressing <Esc> does not immediately exit this menu. Select one of the options from this menu or <F10> from the legend bar to exit.

Save Changes and Exit

Once you are finished making your selections, choose this option from the Exit menu to ensure the values you selected are saved to the CMOS RAM. The CMOS RAM is sustained by an onboard backup battery and stays on even when the PC is turned off. When you select this option, a confirmation window appears. Select [Yes] to save changes and exit.



If you attempt to exit the Setup program without saving your changes, the program prompts you with a message asking if you want to save your changes before exiting. Pressing <Enter> saves the changes while exiting.

Discard Changes and Exit

Select this option only if you do not want to save the changes that you made to the Setup program. If you made changes to fields other than system date, system time, and password, the BIOS asks for a confirmation before exiting.

Discard Changes

This option allows you to discard the selections you made and restore the previously saved values. After selecting this option, a confirmation appears. Select [Yes] to discard any changes and load the previously saved values.

Load Optimal Defaults

This option allows you to load the default values for each of the parameters on the Setup menus. When you select this option or if you press <F5>, a confirmation window appears. Select [Yes] to load default values. Select Exit Saving Changes or make other changes before saving the values to the non-volatile RAM.

Load Failsafe Defaults

Use this option to load all default failsafe setup values. Use this option when troubleshooting

this page intentionally left blank

Chapter 6

This chapter gives information about the ZMAX Software, drivers, and utilities operation.

A vertical grey bar on the right side of the page containing the chapter title.

Drivers and Utilities

Drivers and Utilities

The ZMAXdp series comes bundled with a Power Installer CD-ROM disc that includes driver and utility software. This chapter describes installing and using this software.

Running the Power Installer Disc

The Power Installer CD-ROM install interface runs under Microsoft Windows 9X, NT 4.0, 2000, or XP. After inserting the disc into your CD-ROM drive the install interface loads automatically. Choose model ZMAX from the selections. If it does not load, run the Power Installer directly from the disc by running Setup.

Drivers and Utilities Screen

This screen has five selections. Choose a selection to open its respective screen, which are described below. The **User's Manual** selection opens the motherboard documentation. Choose **Exit** to leave this screen.

Drivers Installation Screen

Click "**Driver Installation**" in the Drivers and Utilities screen and the Driver Installation screen appears. Choose drivers in sequence to open their respective install programs. Select the installation guides to review installation information. When you are finished click "**Exit**" to leave this screen.

Software Utility Screen

Click **Software Utility** in the Drivers and Utilities screen and the Software Utility screen appears. To install the **Adobe Acrobat Reader** software, click on the item you wish to install and follow the instructions. Clicking on the **Hardware Monitor Utility** lets you install a program that gives access to information detected by the hardware monitor.

Chapter 7

This chapter gives information about the ZMAX detail Hardware Specifications. For more information of IWILL ZMAXdp, visit IWILL website at <http://www.iwill.net>

Products specification and details may change without notice.

Specification

Specifications

Processor	System Bus
Supports AMD Opteron CPU with 940 PGA Up to 2-way Supports 200 series Opteron Supports 1MB L2 cache Enables simultaneous 32- and 64-bit Computing	Scalable Hyper-Transport Bus technology High throughput (6.4GB/sec)
Chipset	Drive Bay
nVIDIA® nForce3 Professional MCP TI® IEEE1394 TSB43AB22PDT Host Controller Marvell® 88E1111 PHY Native nVIDIA® Ethernet MAC	One 5.25" internal drive bay for optical driver Two 3.5" drive bay for IDE HDD (IDE or SATA) One 3.5" space for Floppy drive or card reader
System memory	USB
DDR400/333 SDRAM Support PC3200/ PC2700/ PC2100/ PC1600 ECC 2x DDR DIMMs Maximum system memory up to 2GB	Eight USB 2.0 Offer up to 480MB/s Four USB 2.0 external ports on the rear panel Four USB 2.0 external ports on the front panel
Graphics	Expansion Slot
Supports 8X AGP slot One universal 1.5V or 0.8V AGP 3.0 connector	One AGP 8X slot available One 32-bit, 33MHz PCI slot One Mini-PCI slot
Audio	Rear Panel I/O
6 Channel Audio utilizes the Realtek® ALC655 codec Line in/ Speaker/ Mic on rear panel Earphone/ Mic on front panel SPDIF optical audio In and Out	USB 2.0: Eight (4 front and 4 rear) Firewire (1xfront) Headphone: One (front, one rear) Line Out: Two (1 front and 1 rear) Line in: Two (one front) Serial: Two (rear) PS/2 Keyboard: One (rear) PS/2 Mouse: One (rear) RJ45: One (rear)
LAN	Dimension
nVidia® GbE MAC + Realtek RTL8110S PHY	Height: 222 mm Width: 213 mm Depth: 362 mm

IEEE-1394	Power Supply
IEEE1394-1394A compliant OHCI compatible interface One IEEE1394 ports on the front panel; 100/200/400 Mbps data transfer rates	300 Watt power supply with fully support ATX specification
NVRAID™	Weight
Provides support for RAID 0, RAID 1 Enabling the highest disk data transfer rates Supports both SATA and ATA-133 interface	8.22KG (Net weight)
Firewall	Certification
High-performance, native hardware-optimized solution Advanced management functionality-remote access, configuration, and monitoring Improves throughput and protection, and lowers CPU utilization Easy Configuration with Web-Based Browser Interface	FCC class B; CE mark 89/336/ECC(EMV)

Specifications are subject to change without notice.

Free Manuals Download Website

<http://myh66.com>

<http://usermanuals.us>

<http://www.somanuals.com>

<http://www.4manuals.cc>

<http://www.manual-lib.com>

<http://www.404manual.com>

<http://www.luxmanual.com>

<http://aubethermostatmanual.com>

Golf course search by state

<http://golfingnear.com>

Email search by domain

<http://emailbydomain.com>

Auto manuals search

<http://auto.somanuals.com>

TV manuals search

<http://tv.somanuals.com>